



## Main

Range of product	Zelio Relay
Product or component type	Solid state relay
Provided equipment	Thermal pad
Device short name	SSP1
Mounting support	Panel
Phase	1 phase
Contacts type and composition	1 NO
Line Rated Current	125 A
Solid state output type	Zero voltage switching SCR output

## Complementary

[Uc] control circuit voltage	4...32 V DC
Minimum switching voltage	4 V DC turn-on
Maximum switching voltage	1 V DC turn-off
Response time	0.5 cycle turn-on 0.5 cycle turn-off
Input current limits	7...12 mA
Output voltage	48...660 V AC
Load current	0.15...125 A
Absolute maximum voltage	1200 V
Surge current	<= 1750 A for 16.6 ms
Maximum I <sup>2</sup> t for fusing	12709 A <sup>2</sup> .s for 8.33 ms at 60 Hz half cycle 13950 A <sup>2</sup> .s for 10 ms at 50 Hz half cycle
Protection device type	Type 1 - 80 A miniature circuit breaker (MCB) - curve B Type 2 - 63 A miniature circuit breaker (MCB) - curve B
Leakage current	<= 1 mA off-state
Voltage drop	1.15 V on-state
DV/dt	500 V/μs off-state at maximum voltage
Cos phi	0.5 with maximum load
Motor power hp	2 hp 120 V AC 5 hp 240 V AC 10 hp 480 V AC
Insulation resistance	1000 MOhm at 500 V DC
Capacitance unbalance	8 pF input/output
Dielectric strength	4 kV AC input/output 4 kV AC input or output to case
[Uimp] rated impulse withstand voltage	6 kV output to case 6 kV input to output
Tightening torque	1.5...1.7 N.m input 2...2.2 N.m output
Connections - terminals	Forked type tag connectors : 9.2 x 4 mm input Ring lugs : 9.2 x 4 mm input Forked type tag connectors : 11.7 x 4.5 mm output Ring lugs : 11.7 x 4.5 mm output Screw terminals : 0.2...3.3 mm <sup>2</sup> , (AWG 24...AWG 12) with cable end input Screw terminals : 0.5...5.26 mm <sup>2</sup> , (AWG 20...AWG 10) with cable end output Screw terminals : 0.2...3.3 mm <sup>2</sup> , (AWG 24...AWG 12) without cable end input Screw terminals : 0.5...8.26 mm <sup>2</sup> , (AWG 20...AWG 8) without cable end output
Thermal resistance	0.22 °C/W junction to case
Thermal impedance	0.48 °C-in <sup>2</sup> /W at 25 psi

The information provided in this documentation contains general descriptions and/or technical characteristics of the products contained herein. This documentation is not intended as a substitute for and is not to be used for determining suitability or reliability of these products for specific user applications. It is the duty of any such user or integrator to perform the appropriate and complete risk analysis, evaluation and testing of the products with respect to the relevant specific application or use thereof. Neither Schneider Electric Industries SAS nor any of its affiliates or subsidiaries shall be responsible or liable for misuse of the information contained herein.

Local signalling	LED, green input
IP degree of protection	IP20
Safety reliability data	MTTFd = 1875.9 years B10d = 1731395
Product weight	3.15 oz (89.2 g)

## Environment

ambient air temperature for operation	-40...176 °F (-40...80 °C)
ambient air temperature for storage	-40...257 °F (-40...125 °C)
pollution degree	2
overvoltage category	III
product certifications	CE CSA RoHS UL REACH EAC
marking	CE CSA UL EAC
standards	EN/IEC 60950-1 UL 508 EN/IEC 62314 CSA C22.2 No 14-13

## Offer Sustainability

Green Premium product	Green Premium product
Compliant - since 1522 - Schneider Electric declaration of conformity	Compliant - since 1522 - Schneider Electric declaration of conformity
Reference not containing SVHC above the threshold	Reference not containing SVHC above the threshold
Available	Available
Available	Available
WARNING: This product can expose you to chemicals including:	WARNING: This product can expose you to chemicals including:
Lead and lead compounds, which is known to the State of California to cause cancer and birth defects or other reproductive harm.	Lead and lead compounds, which is known to the State of California to cause cancer and birth defects or other reproductive harm.
For more information go to <a href="http://www.p65warnings.ca.gov">www.p65warnings.ca.gov</a>	For more information go to <a href="http://www.p65warnings.ca.gov">www.p65warnings.ca.gov</a>

## Dimensions

mm  
in.

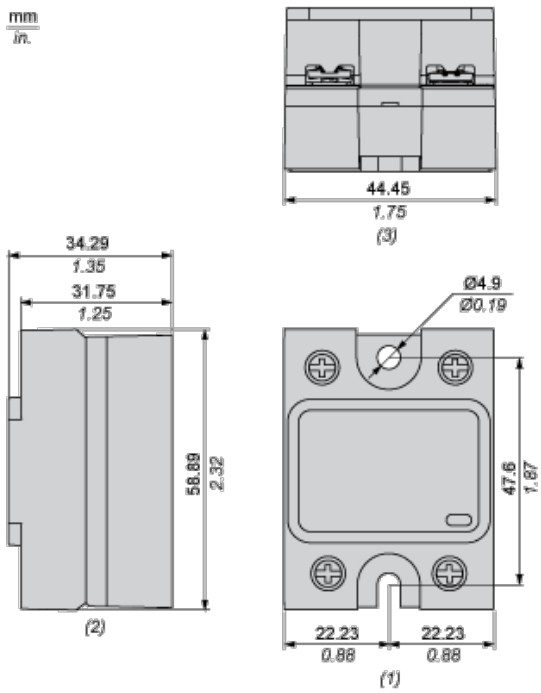

- (1) Front view
- (2) Side view
- (3) Bottom view

## Derating Curves

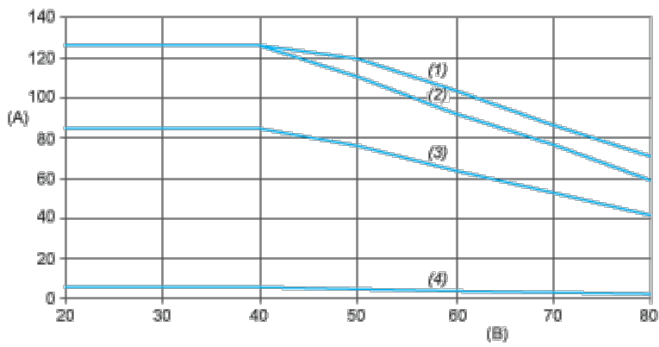

- A : Load Current (Arms)
- B : Ambient Temperature (°C)
- (1) For Heatsink SSRHP02
- (2) For Heatsink SSRHP05
- (3) For Heatsink SSRHP07
- (4) No Heatsink



## Стандарт Электрон Связь

Мы молодая и активно развивающаяся компания в области поставок электронных компонентов. Мы поставляем электронные компоненты отечественного и импортного производства напрямую от производителей и с крупнейших складов мира.

Благодаря сотрудничеству с мировыми поставщиками мы осуществляем комплексные и плановые поставки широчайшего спектра электронных компонентов.

Собственная эффективная логистика и склад в обеспечивает надежную поставку продукции в точно указанные сроки по всей России.

Мы осуществляем техническую поддержку нашим клиентам и предпродажную проверку качества продукции. На все поставляемые продукты мы предоставляем гарантию .

Осуществляем поставки продукции под контролем ВП МО РФ на предприятия военно-промышленного комплекса России , а также работаем в рамках 275 ФЗ с открытием отдельных счетов в уполномоченном банке. Система менеджмента качества компании соответствует требованиям ГОСТ ISO 9001.

Минимальные сроки поставки, гибкие цены, неограниченный ассортимент и индивидуальный подход к клиентам являются основой для выстраивания долгосрочного и эффективного сотрудничества с предприятиями радиоэлектронной промышленности, предприятиями ВПК и научно-исследовательскими институтами России.

С нами вы становитесь еще успешнее!

### Наши контакты:

**Телефон:** +7 812 627 14 35

**Электронная почта:** [sales@st-electron.ru](mailto:sales@st-electron.ru)

**Адрес:** 198099, Санкт-Петербург,  
Промышленная ул, дом № 19, литера Н,  
помещение 100-Н Офис 331