

NHD-2.4-240320CF-CSXN#-FT

TFT (Thin-Film Transistor) Liquid Crystal Display Module

NHD-	Newhaven Display
2.4-	2.4" Diagonal
240320-	240 x 320 Pixels (Portrait Mode)
CF-	Model
C-	Built-in Controller
S-	Sunlight Readable
X-	TFT
N-	TN, 6:00 Optimal View, Wide Temperature
#-	RoHS Compliant
F-	FFC ZIF Connection Style
T-	4-Wire Resistive Touch Panel

Newhaven Display International, Inc.

2661 Galvin Ct.

Elgin IL, 60124

Ph: 847-844-8795

Fax: 847-844-8796

www.newhavendisplay.com

nhtech@newhavendisplay.com

nhsales@newhavendisplay.com

Document Revision History

Revision	Date	Description	Changed by
0	9/25/15	Initial Release	SB
1	2/17/16	Corrected Brightness Condition, Datasheet Reformat	SB
2	3/21/16	Updated Mechanical Drawing, Added Backlight Lifetime	SB
3	4/7/16	Viewing Angle Clarification, Brightness Updated	SB

Functions and Features

- 240 x 320 pixels
- White LED backlight
- 3.3V power supply
- 8-bit or 16-bit Parallel MPU interface
- FFC ZIF I/O connection
- Built-in ST7789S controller
- 262K colors
- 4-wire Resistive Touch Panel
- Sunlight Readable

Mechanical Drawing

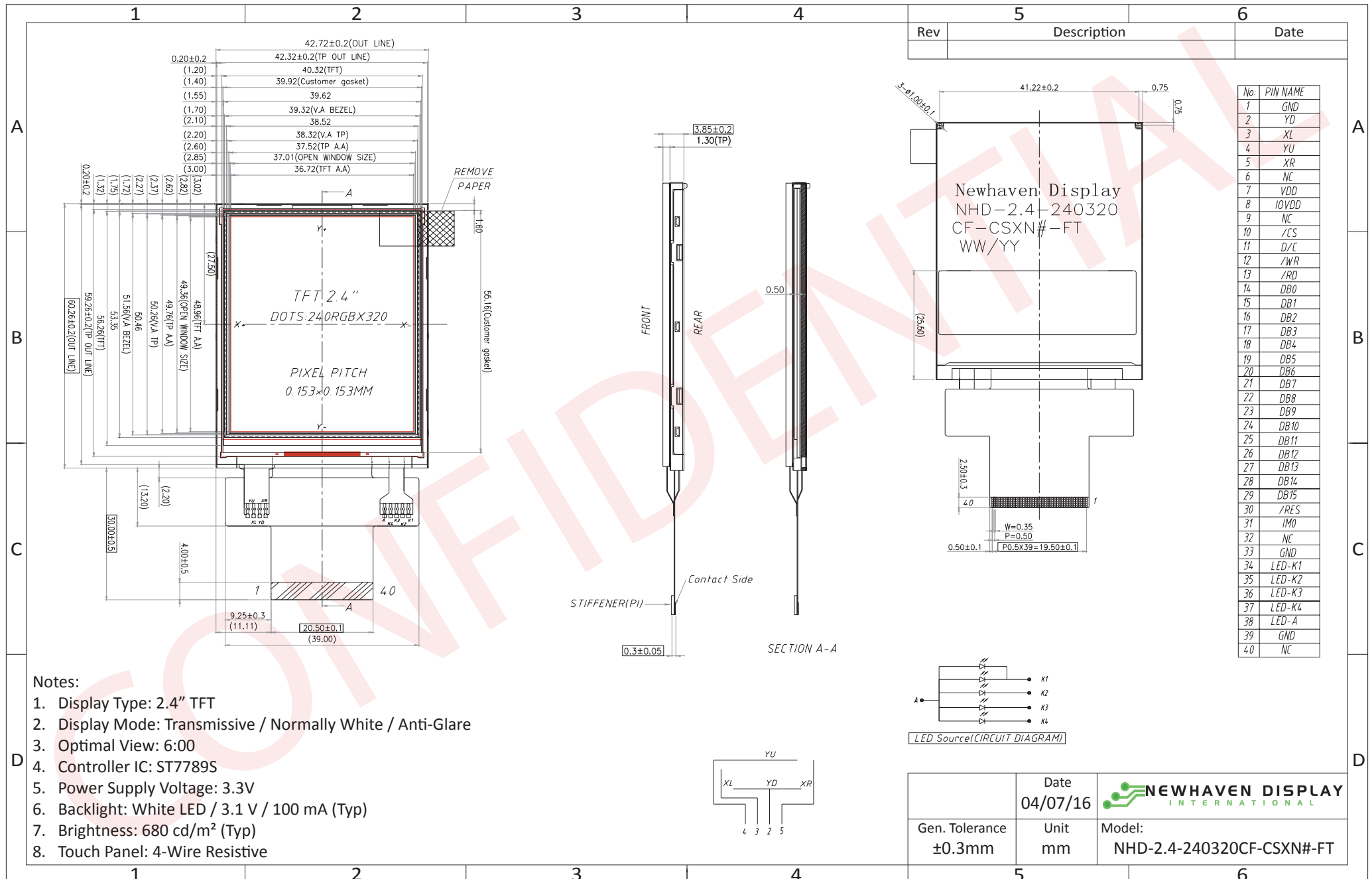

The drawing contained herein is the exclusive property of Newhaven Display International, Inc. and shall not be copied, reproduced, and/or disclosed in any format without permission.

Pin Description

Pin No.	Symbol	External Connection	Function Description
1	GND	Power Supply	Ground
2	YD	Touch Controller	Touch Panel – Down
3	XL	Touch Controller	Touch Panel – Left
4	YU	Touch Controller	Touch Panel – Up
5	XR	Touch Controller	Touch Panel – Right
6	NC	-	No Connect
7	VDD	Power Supply	Supply Voltage for LCD (3.3V)
8	IOVDD	Power Supply	Supply Voltage for Logic (1.8V)
9	NC	-	No Connect
10	/CS	MPU	Active LOW Chip Select signal (can tie to GND)
11	D/C	MPU	Data / Command selection: '1' = Data ; '0' = Command
12	/WR	MPU	Active LOW Write signal
13	/RD	MPU	Active LOW Read signal
14	DB0	MPU	Bi-directional data bus 8-bit: use DB8-DB15 16-bit: use DB0-DB15
15	DB1	MPU	
16	DB2	MPU	
17	DB3	MPU	
18	DB4	MPU	
19	DB5	MPU	
20	DB6	MPU	
21	DB7	MPU	
22	DB8	MPU	
23	DB9	MPU	
24	DB10	MPU	
25	DB11	MPU	
26	DB12	MPU	
27	DB13	MPU	
28	DB14	MPU	
29	DB15	MPU	
30	/RES	MPU	Active LOW Reset signal
31	IM0	MPU	IM0=0: 16-bit i80 IM0=1: 8-bit i80
32	NC	-	No Connect
33	GND	Power Supply	Ground
34	LED-K1	Power Supply	Backlight Cathode (Ground)
35	LED-K2	Power Supply	Backlight Cathode (Ground)
36	LED-K3	Power Supply	Backlight Cathode (Ground)
37	LED-K4	Power Supply	Backlight Cathode (Ground)
38	LED-A	Power Supply	Backlight Anode (3.1V)
39	GND	Power Supply	Ground
40	NC	-	No Connect

Recommended LCD connector: 40-pin, 0.5mm pitch FFC connector

Molex P/N: 54132-4062 or similar

Wiring Diagram

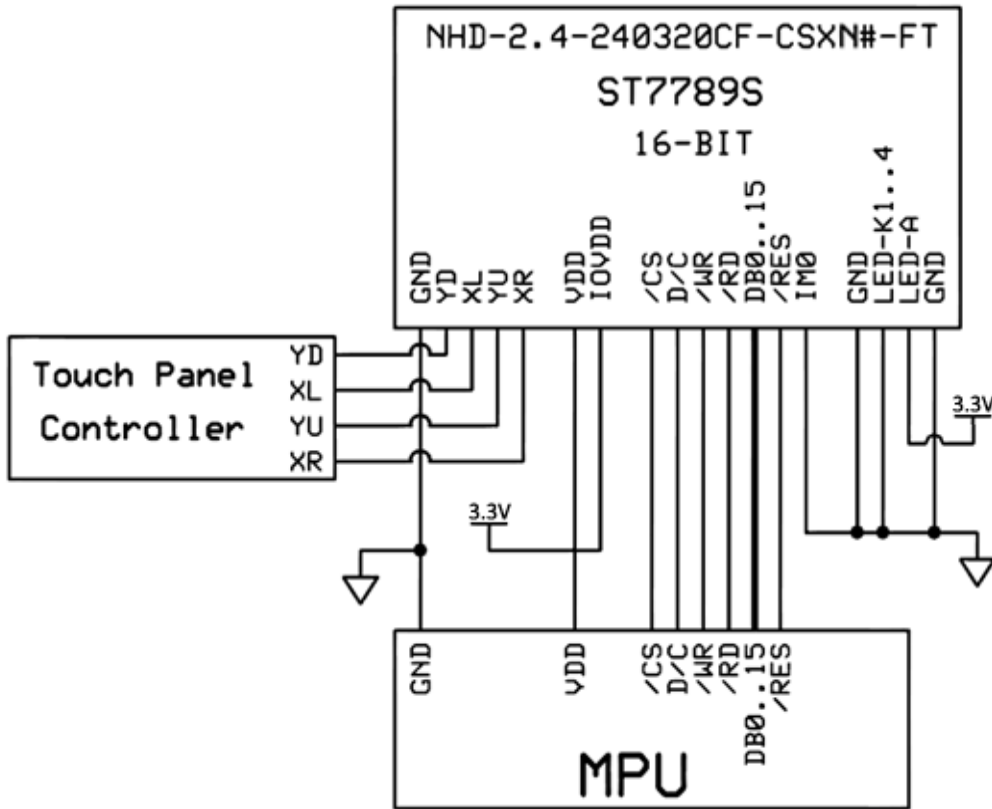
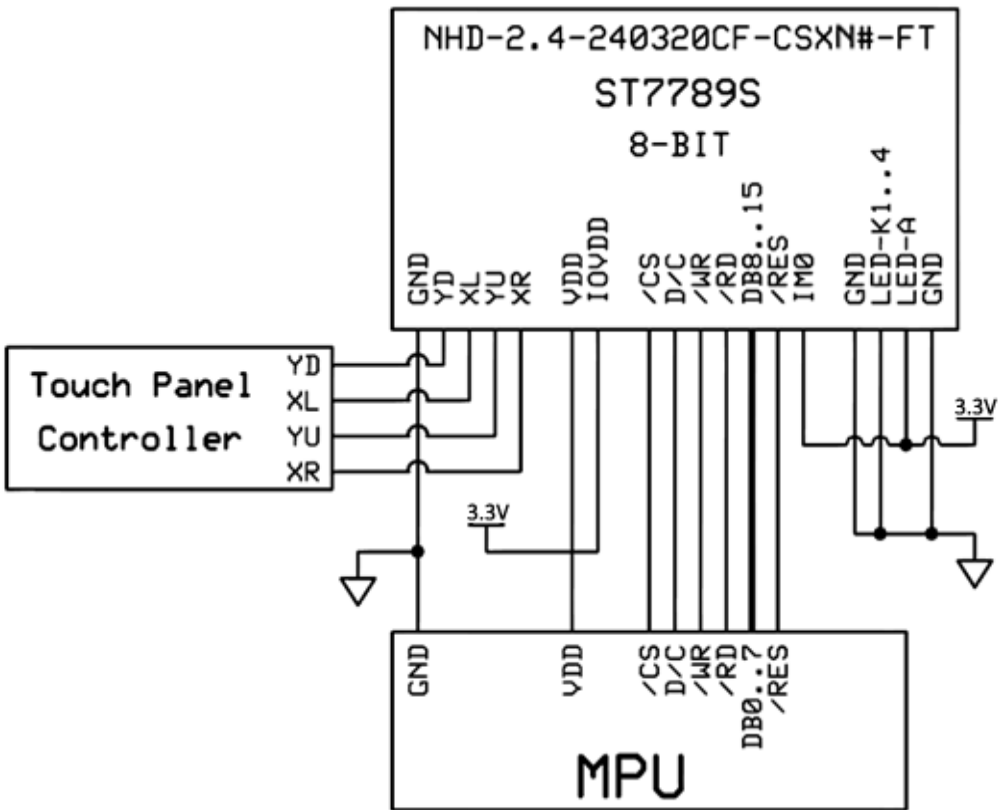

Electrical Characteristics

Item	Symbol	Condition	Min.	Typ.	Max.	Unit
Operating Temperature Range	Top	Absolute Max	-20	-	+70	°C
Storage Temperature Range	Tst	Absolute Max	-30	-	+80	°C
Supply Voltage for LCD	VDD	-	2.4	3.3	3.5	V
Supply Current	IDD	VDD=3.3V	-	6	12	mA
"H" Level input	Vih	-	0.7*VDD	-	VDD	V
"L" Level input	Vil	-	GND	-	0.3*VDD	V
"H" Level output	Voh	-	0.8*VDD	-	VDD	V
"L" Level output	Vol	-	GND	-	0.2*VDD	V
Backlight Supply Voltage	Vled	-	2.8	3.1	3.5	V
Backlight Supply Current	Iled	Vled=3.1V	-	100	125	mA
Backlight Lifetime*	-	ILED = 100 mA Top = 25° C	20,000	50,000	-	Hrs.

*Backlight Lifetime is rated as Hours until **half-brightness**, under normal operating conditions.

Optical Characteristics

Item	Symbol	Condition	Min.	Typ.	Max.	Unit
Optimal Viewing Angles	Top	Cr ≥ 10	-	50	-	°
	Bottom		-	55	-	°
	Left		-	55	-	°
	Right		-	55	-	°
Contrast Ratio	Cr	-	150	200	-	-
Luminance	Lv	Iled = 100mA	560	680	-	cd/m ²
Response Time	Rise	Tr	-	4	8	ms
	Fall	Tf	-	12	24	ms

Touch Panel Characteristics

Item	Min.	Typ.	Max.	Unit
Linearity	-	-	1.5	%
Circuit Resistance – X-Axis	200	-	600	Ω
Circuit Resistance – Y-Axis	250	-	900	Ω
Insulation Resistance	20	-	-	MΩ
Operating Voltage	-	-	5	V
Chattering	-	-	15	ms
Activation Force	100	-	-	g
Pen Writing Durability	100,000	-	-	Characters
Pitting Durability	1,000,000	-	-	Touches
Surface Hardness	3	-	-	H

Controller Information

Built-in ST7789S controller.

Please download specification at http://www.newhavendisplay.com/app_notes/ST7789S.pdf

Table of Commands

Please download specification at http://www.newhavendisplay.com/app_notes/ST7789S.pdf

Timing Characteristics

Parallel 18/16/9/8-bit Interface Timing Characteristics (8080-II system)

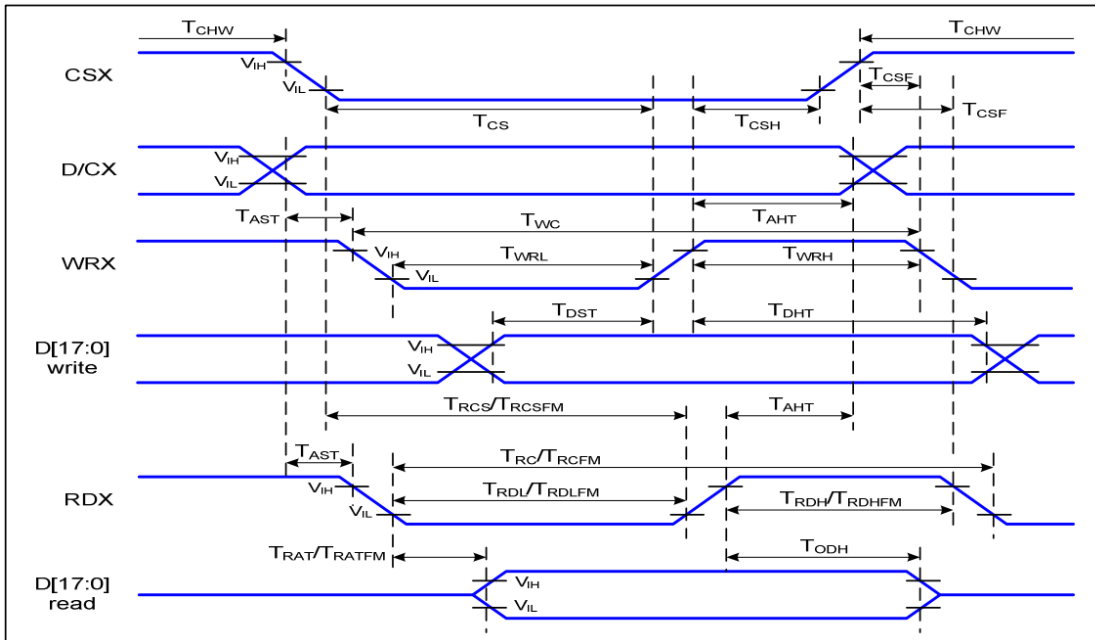

Signal	Symbol	Parameter	Min	Max	Unit	Description
D/CX	T_{AST}	Address setup time	0		ns	-
	T_{AHT}	Address hold time (Write/Read)	10		ns	
CSX	T_{CHW}	Chip select "H" pulse width	0		ns	-
	T_{CS}	Chip select setup time (Write)	15		ns	
	T_{RCS}	Chip select setup time (Read ID)	45		ns	
	T_{RCSFM}	Chip select setup time (Read FM)	355		ns	
	T_{CSF}	Chip select wait time (Write/Read)	10		ns	
	T_{CSH}	Chip select hold time	10		ns	
WRX	T_{WC}	Write cycle	66		ns	-
	T_{WRH}	Control pulse "H" duration	15		ns	
	T_{WRL}	Control pulse "L" duration	15		ns	
RDX (ID)	T_{RC}	Read cycle (ID)	160		ns	When read ID data
	T_{RDH}	Control pulse "H" duration (ID)	90		ns	
	T_{RDL}	Control pulse "L" duration (ID)	45		ns	
RDX (FM)	T_{RCFM}	Read cycle (FM)	450		ns	When read from frame memory
	T_{RDHFM}	Control pulse "H" duration (FM)	90		ns	
	T_{RDLFM}	Control pulse "L" duration (FM)	355		ns	
D[17:0]	T_{DST}	Data setup time	10		ns	For CL=30pF
	T_{DHT}	Data hold time	10		ns	
	T_{RAT}	Read access time (ID)		40	ns	
	T_{RATFM}	Read access time (FM)		340	ns	
	T_{ODH}	Output disable time	20	80	ns	

Reset Timing

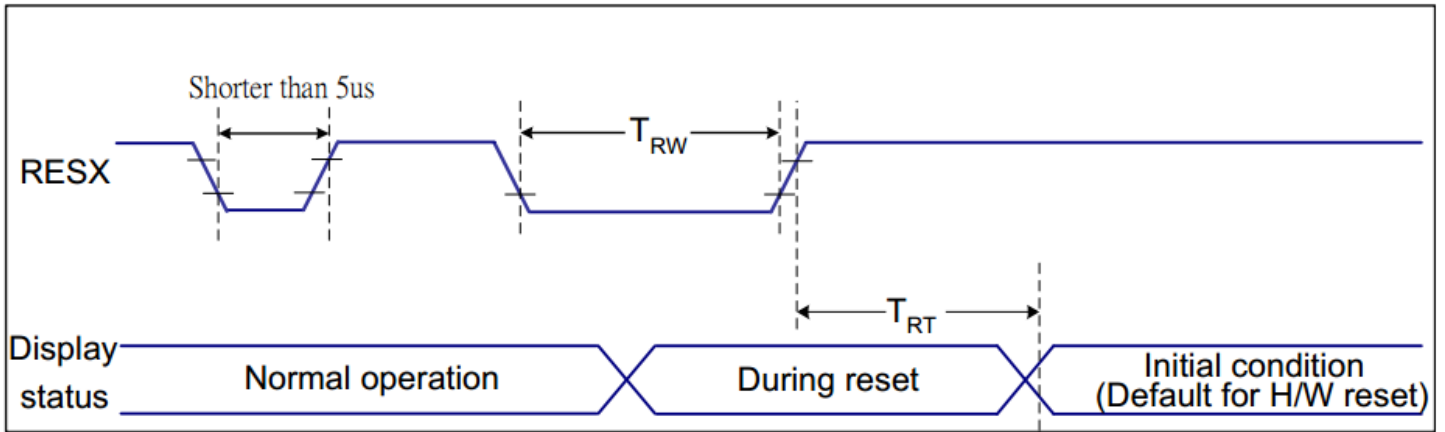

Related Pins	Symbol	Parameter	MIN	MAX	Unit
RESX	TRW	Reset pulse duration	10	-	us
	TRT	Reset cancel	-	5 (Note 1, 5)	ms
				120 (Note 1, 6, 7)	ms

Power ON/OFF Sequence

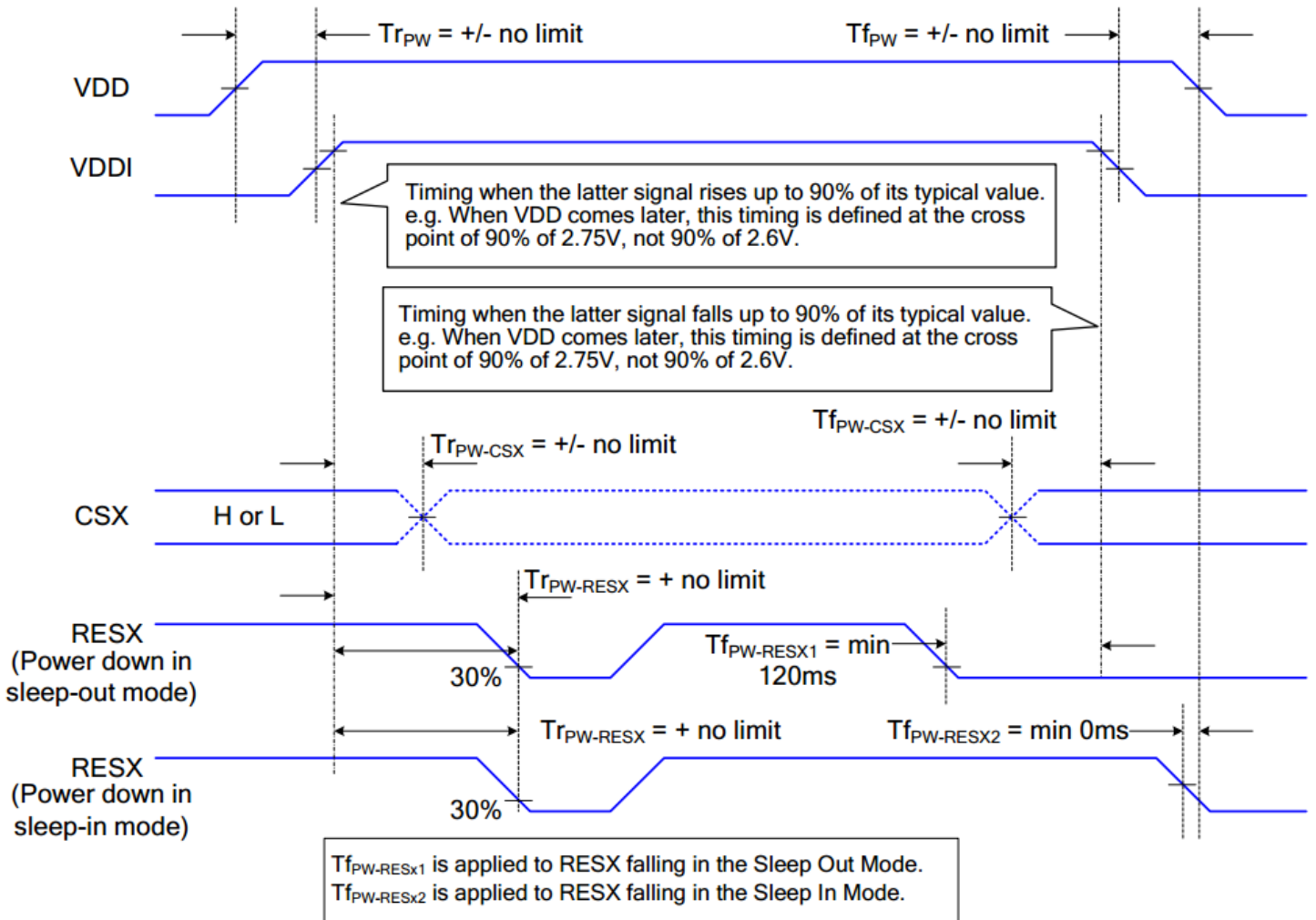

Example Initialization Code

```
/*
void TFT_24_7789_Write_Command(unsigned int command)
{
  GPIO_ResetBits(GPIOC, CS1);
  GPIO_ResetBits(GPIOC, RS);
  GPIO_SetBits(GPIOC, nRD);
  GPIO_ResetBits(GPIOC, nWR);
  GPIO_Write(GPIOB, command);
  TFT_delay(10);
  GPIO_SetBits(GPIOC, nWR);
  TFT_delay(1);
}
*/
void TFT_24_7789_Write_Data(unsigned int data1)
{
  GPIO_Write(GPIOB, data1);
  GPIO_SetBits(GPIOC, RS);
  GPIO_ResetBits(GPIOC, nWR);
  TFT_delay(1);
  GPIO_SetBits(GPIOC, nWR);
}
/*
void TFT_24_7789_Init(void)
{
  int n;
  GPIO_ResetBits(GPIOC, CS1);
  GPIO_SetBits(GPIOC, nRD);
  GPIO_ResetBits(GPIOC, nWR);
  GPIO_WriteBit(GPIOC, RES, Bit_RESET);
  TFT_delay(100);
  GPIO_WriteBit(GPIOC, RES, Bit_SET);
  TFT_delay(100);
  TFT_24_7789_Write_Command(0x0011); //exit SLEEP mode
  TFT_delay(100);

  TFT_24_7789_Write_Command(0x0036);
  TFT_24_7789_Write_Data(0x0080); //MADCTL: memory data access control
  TFT_24_7789_Write_Command(0x003A);
  TFT_24_7789_Write_Data(0x0066); //COLMOD: Interface Pixel format
  TFT_24_7789_Write_Command(0x00B2);
  TFT_24_7789_Write_Data(0x000C);
  TFT_24_7789_Write_Data(0x0C);
  TFT_24_7789_Write_Data(0x00);
  TFT_24_7789_Write_Data(0x33);
  TFT_24_7789_Write_Data(0x33); //PORCTRK: Porch setting
  TFT_24_7789_Write_Command(0x00B7);
  TFT_24_7789_Write_Data(0x0035); //GCTRL: Gate Control
  TFT_24_7789_Write_Command(0x00BB);
  TFT_24_7789_Write_Data(0x002B); //VCOMS: VCOM setting
  TFT_24_7789_Write_Command(0x00C0);
  TFT_24_7789_Write_Data(0x002C); //LCMCTRL: LCM Control
  TFT_24_7789_Write_Command(0x00C2);
  TFT_24_7789_Write_Data(0x0001);
  TFT_24_7789_Write_Data(0xFF); //VDVVRHEN: VDV and VRH Command Enable
  TFT_24_7789_Write_Command(0x00C3);
  TFT_24_7789_Write_Data(0x0011); //VRHS: VRH Set
  TFT_24_7789_Write_Command(0x00C4);
}
*/
```

```

TFT_24_7789_Write_Data(0x0020);//VDVS: VDV Set
TFT_24_7789_Write_Command(0x00C6);
TFT_24_7789_Write_Data(0x000F);//FRCTRL2: Frame Rate control in normal mode
TFT_24_7789_Write_Command(0x00D0);
TFT_24_7789_Write_Data(0x00A4);
TFT_24_7789_Write_Data(0xA1);//PWCTRL1: Power Control 1
TFT_24_7789_Write_Command(0x00E0);
TFT_24_7789_Write_Data(0x00D0);
TFT_24_7789_Write_Data(0x0000);
TFT_24_7789_Write_Data(0x0005);
TFT_24_7789_Write_Data(0x000E);
TFT_24_7789_Write_Data(0x0015);
TFT_24_7789_Write_Data(0x000D);
TFT_24_7789_Write_Data(0x0037);
TFT_24_7789_Write_Data(0x0043);
TFT_24_7789_Write_Data(0x0047);
TFT_24_7789_Write_Data(0x0009);
TFT_24_7789_Write_Data(0x0015);
TFT_24_7789_Write_Data(0x0012);
TFT_24_7789_Write_Data(0x0016);
TFT_24_7789_Write_Data(0x0019);//PVGAMCTRL: Positive Voltage Gamma control
TFT_24_7789_Write_Command(0x00E1);
TFT_24_7789_Write_Data(0x00D0);
TFT_24_7789_Write_Data(0x0000);
TFT_24_7789_Write_Data(0x0005);
TFT_24_7789_Write_Data(0x000D);
TFT_24_7789_Write_Data(0x000C);
TFT_24_7789_Write_Data(0x0006);
TFT_24_7789_Write_Data(0x002D);
TFT_24_7789_Write_Data(0x0044);
TFT_24_7789_Write_Data(0x0040);
TFT_24_7789_Write_Data(0x000E);
TFT_24_7789_Write_Data(0x001C);
TFT_24_7789_Write_Data(0x0018);
TFT_24_7789_Write_Data(0x0016);
TFT_24_7789_Write_Data(0x0019);//NVGAMCTRL: Negative Voltage Gamma control
TFT_24_7789_Write_Command(0x002A);
TFT_24_7789_Write_Data(0x0000);
TFT_24_7789_Write_Data(0x0000);
TFT_24_7789_Write_Data(0x0000);
TFT_24_7789_Write_Data(0x00EF);//X address set
TFT_24_7789_Write_Command(0x002B);
TFT_24_7789_Write_Data(0x0000);
TFT_24_7789_Write_Data(0x0000);
TFT_24_7789_Write_Data(0x0001);
TFT_24_7789_Write_Data(0x003F);//Y address set

TFT_delay(10);
}
/*****/

```

Quality Information

Test Item	Content of Test	Test Condition	Note
High Temperature Storage	Endurance test applying the high storage temperature for a long time.	+80°C, 96hrs	2
Low Temperature Storage	Endurance test applying the low storage temperature for a long time.	-30°C, 96hrs	1,2
High Temperature Operation	Endurance test applying the electric stress (voltage & current) and the high thermal stress for a long time.	+70°C, 96hrs	2
Low Temperature Operation	Endurance test applying the electric stress (voltage & current) and the low thermal stress for a long time.	-20°C, 96hrs	1,2
High Temperature / Humidity Operation	Endurance test applying the electric stress (voltage & current) and the high thermal with high humidity stress for a long time.	+40°C, 90-95% RH, 96hrs	1,2
Thermal Shock resistance	Endurance test applying the electric stress (voltage & current) during a cycle of low and high thermal stress.	-20°C,30min -> 25°C,5min -> 70°C,30min -> 25°C,5min = 1 cycle. 10 cycles	
Vibration test	Endurance test applying vibration to simulate transportation and use.	10Hz-55Hz, 1.5mm amplitude. 2hrs in each of 3 directions X,Y,Z	3
Static electricity test	Endurance test applying electric static discharge.	VS=8KV, RS=330kΩ, CS=150pF Ten times	

Note 1: No condensation to be observed.

Note 2: Conducted after 4 hours of storage at 25°C, 0%RH.

Note 3: Test performed on product itself, not inside a container.

Precautions for using LCDs/LCMs

See Precautions at www.newhavendisplay.com/specs/precautions.pdf

Warranty Information

See Terms & Conditions at http://www.newhavendisplay.com/index.php?main_page=terms



Стандарт Электрон Связь

Мы молодая и активно развивающаяся компания в области поставок электронных компонентов. Мы поставляем электронные компоненты отечественного и импортного производства напрямую от производителей и с крупнейших складов мира.

Благодаря сотрудничеству с мировыми поставщиками мы осуществляем комплексные и плановые поставки широчайшего спектра электронных компонентов.

Собственная эффективная логистика и склад в обеспечивает надежную поставку продукции в точно указанные сроки по всей России.

Мы осуществляем техническую поддержку нашим клиентам и предпродажную проверку качества продукции. На все поставляемые продукты мы предоставляем гарантию .

Осуществляем поставки продукции под контролем ВП МО РФ на предприятия военно-промышленного комплекса России , а также работаем в рамках 275 ФЗ с открытием отдельных счетов в уполномоченном банке. Система менеджмента качества компании соответствует требованиям ГОСТ ISO 9001.

Минимальные сроки поставки, гибкие цены, неограниченный ассортимент и индивидуальный подход к клиентам являются основой для выстраивания долгосрочного и эффективного сотрудничества с предприятиями радиоэлектронной промышленности, предприятиями ВПК и научно-исследовательскими институтами России.

С нами вы становитесь еще успешнее!

Наши контакты:

Телефон: +7 812 627 14 35

Электронная почта: sales@st-electron.ru

Адрес: 198099, Санкт-Петербург,
Промышленная ул, дом № 19, литера Н,
помещение 100-Н Офис 331