

Multi Camera Interface ICs

■ DESCRIPTIONS

The S2D13P04 is a camera interface IC designed for automotive multiple camera systems. The S2D13P04 integrates four-channel NTSC/PAL video decoders, which allow to connect four analog cameras simultaneously, and synchronously output the image data asynchronously input from the four cameras by using internal VRAM. The S2D13P04 also has image processing functions such as image composition of the four camera image data, distortion correction, and interlaced-to-progressive scan conversion. The S2D13P04 has a large-capacity VRAM built in, so it does not require an external memory.

■ FEATURES

- Video Input
 - Analog Video (CVBS) Input – 4 inputs
 - PAL/NTSC Decoder – 4 channels
 - NTSC-M, NTSC-J support
 - PAL-M, PAL-B, PAL-G, PAL-I, PAL-N support
- Video Output
 - Digital Output 8-bit YUV422 (with HSYNC/VSYNC) ITU-R BT.656 *1
 - Interlaced Output *2, 3
 - Progressive Output
- Video Output Mode
 - Fixed Mode
 - Auto Scan Mode *4
 - Merge Mode *2
 - Compression Mode *2, 4
- Image Processing
 - Image scaling function
 - Interlaced-to-Progressive Conversion
 - Distortion correction function *3, 4
- Output at stable frame rates
 - 720x480i 30fps (NTSC interlaced output)
 - 640x480p 30fps (NTSC progressive output)
 - 640x480p 30fps (NTSC with distortion correction enabled)
 - 720x576i 25fps (PAL interlaced output)
 - 768x576p 25fps (PAL progressive output)
 - 640x480p 25fps (PAL with distortion correction enabled)
- Host Interface
 - I2C Interface (Slave)
 - SPI Interface (Slave)
- No external RAM required
- Operating Temperature -40 to +85 °C (Ta)
- Operating Voltages Analog: 3.3±0.3V, IO: 3.3±0.3V
Core: 1.8±0.15V, PLL: 1.8±0.15V
- Packages
 - S2D13P04B00B100
PFPGA10UX121 (10mm×10mm×1.2mm, 0.8mm-pitch)
 - S2D13P04F00A100
QFP15-100pin (14mm×14mm×1.7mm, 0.5mm-pitch)

*1 The number of pixels per line may not comply with ITU-R BT.656 standard.

*2 In Merge Mode or Compression Mode, outputs are compatible with Interlaced output.

*3 When the distortion correction function is enabled, the interlaced output is not supported.

*4 In the Compression Mode or Auto Scan Mode, the distortion correction is not supported.

■ BLOCK DIAGRAM

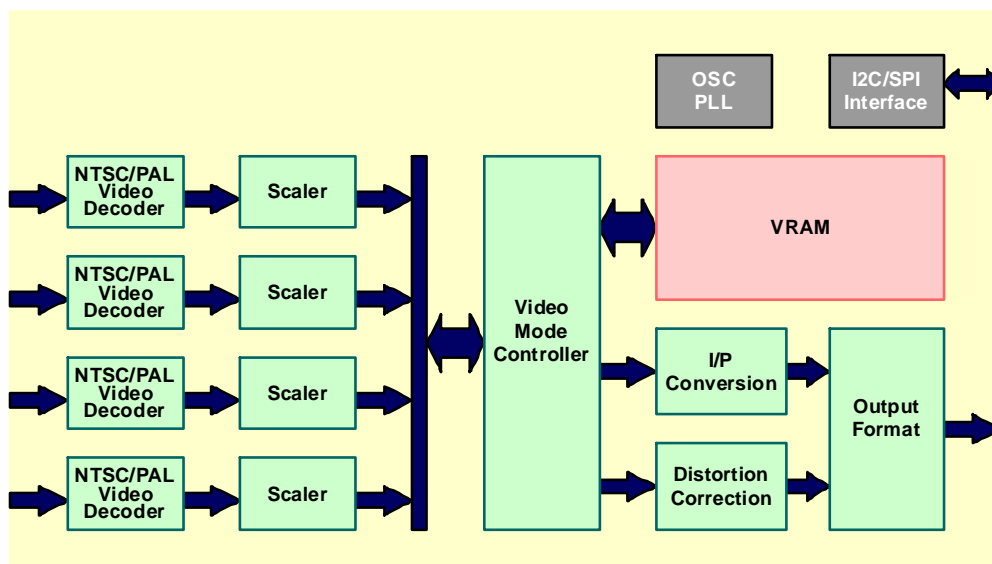

S2D13P04

■ USE CASE

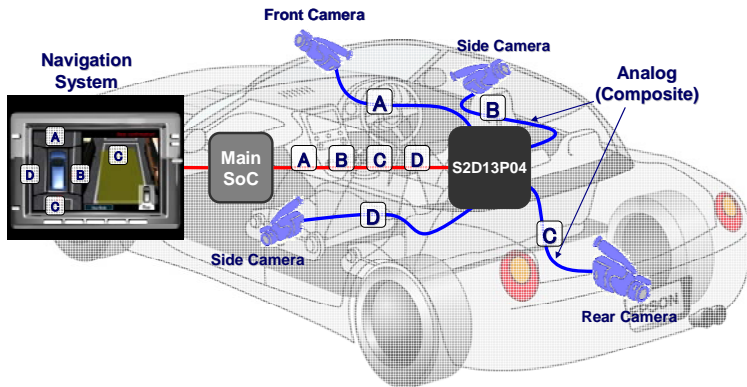

■ OUTPUT DATA FORMAT IMAGE

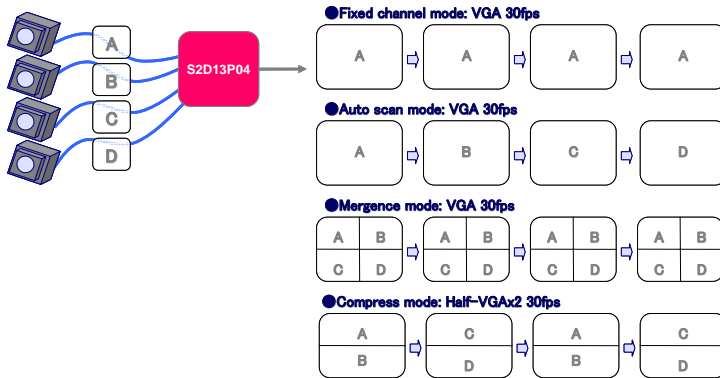

- CONTACT YOUR SALES REPRESENTATIVE FOR THESE COMPREHENSIVE DESIGN TOOLS)
 - S2D13P04 Technical Documentation
 - S2D13P04 Evaluation Boards

NOTICE:

No part of this material may be reproduced or duplicated in any form or by any means without the written permission of Seiko Epson. Seiko Epson reserves the right to make changes to this material without notice. Seiko Epson does not assume any liability of any kind arising out of any inaccuracies contained in this material or due to its application or use in any product or circuit and, further, there is no representation that this material is applicable to products requiring high level reliability, such as, medical products. Moreover, no license to any intellectual property rights is granted by implication or otherwise, and there is no representation or warranty that anything made in accordance with this material will be free from any patent or copyright infringement of a third party. When exporting the products or technology described in this material, you should comply with the applicable export control laws and regulations and follow the procedures required by such laws and regulations. You are requested not to use, to resell, to export and/or to otherwise dispose of the products (and any technical information furnished, if any) for the development and/or manufacture of weapon of mass destruction or for other military purposes.

All brands or product names mentioned herein are trademarks and/or registered trademarks of their respective companies.
 ©Seiko Epson Corporation 2012, All rights reserved

SEIKO EPSON CORPORATION

MICRODEVICES OPERATIONS DIVISION

EPSON semiconductor website

http://www.epson.jp/device/semicon_e/

IC Sales & Marketing Department
 421-8 Hino, Hino-shi, Tokyo 191-8501, JAPAN
 Phone: +81-42-587-5814 FAX: +81-42-587-5117

Document code: 412395701
 First issue July, 2012 in Japan



**Стандарт
Электрон
Связь**

Мы молодая и активно развивающаяся компания в области поставок электронных компонентов. Мы поставляем электронные компоненты отечественного и импортного производства напрямую от производителей и с крупнейших складов мира.

Благодаря сотрудничеству с мировыми поставщиками мы осуществляем комплексные и плановые поставки широчайшего спектра электронных компонентов.

Собственная эффективная логистика и склад в обеспечивает надежную поставку продукции в точно указанные сроки по всей России.

Мы осуществляем техническую поддержку нашим клиентам и предпродажную проверку качества продукции. На все поставляемые продукты мы предоставляем гарантию .

Осуществляем поставки продукции под контролем ВП МО РФ на предприятия военно-промышленного комплекса России , а также работаем в рамках 275 ФЗ с открытием отдельных счетов в уполномоченном банке. Система менеджмента качества компании соответствует требованиям ГОСТ ISO 9001.

Минимальные сроки поставки, гибкие цены, неограниченный ассортимент и индивидуальный подход к клиентам являются основой для выстраивания долгосрочного и эффективного сотрудничества с предприятиями радиоэлектронной промышленности, предприятиями ВПК и научно-исследовательскими институтами России.

С нами вы становитесь еще успешнее!

Наши контакты:

Телефон: +7 812 627 14 35

Электронная почта: sales@st-electron.ru

Адрес: 198099, Санкт-Петербург,
Промышленная ул, дом № 19, литера Н,
помещение 100-Н Офис 331