

"ALWAYS COMPLETE"

**Cogent i.MXL LiteKit for
Freescale MC9328MXL**

Hardware Reference Manual

© 2005

Cogent Computer Systems, Inc.

Table of Contents

1 Warranty.....	3
2 Overview.....	4
2.1 Introduction.....	4
2.2 Reference Documents.....	4
3 On Board Devices.....	5
3.1 CSB536FS Address Map.....	5
3.2 8/16/32Mbyte STRATAFLASH.....	5
3.3 64Mbyte SDRAM.....	5
3.4 Cirrus Logic CS8900a Ethernet Controller.....	5
3.5 ADS7846E 4-Wire Touch Controller.....	6
3.6 Wolfson Microelectronics WM8731 I2S Codec.....	6
3.7 GPIO LED's and Switches.....	6
3.8 I2C LED's and Switches.....	6
3.9 3.5" QVGA TFT LCD with Touch.....	7
4 MC9328MXL On-Chip I/O Devices.....	8
4.1 Overview.....	8
4.2 MC9328MXL Chip Selects.....	8
4.3 MC9328MXL General Purpose I/O Port Pin Assignments.....	8
4.4 MC9328MXL Interrupt Pin Assignments.....	12
4.5 MC9328MXL Debug UART.....	13
4.6 MC9328MXL SPI Controller.....	13
4.7 MC9328MXL I2C Interface.....	13
4.8 MC9328MXL 4-Bit SD/MMC Controller.....	13
4.9 MC9328MXL Compact Flash.....	14
4.10 MC9328MXL USB Device Port.....	14
4.11 TFT LCD Controller.....	14
5 Power and JTAG.....	16
5.1 Overview.....	16
5.2 3.3V Switching Regulator.....	16
5.3 Macraigor USBDemon.....	16
6 CSB536FS Software.....	17
6.1 Overview.....	17
7 CSB536FS CPU Module Connectors, LED's and Switches.....	18
7.1 Overview.....	18
7.2 CSB536FS Expansion Connector.....	18
7.3 CSB536FS Expansion Connectors.....	18
7.4 CSB536FS Expansion Connector Pinouts.....	19
7.5 CSB536FS Topside Connectors, LED's and Switches.....	23
8 CSB935FS Breakout Board Connectors, LED's and Switches.....	24
8.1 Overview.....	24
8.2 CSB935FS Connectors, LED's and Switches - Topside.....	24
8.3 CSB935FS Connectors, LED's and Switches – Backside.....	25
9 Micromonitor.....	26
9.1 Introduction to Micromonitor.....	26
9.2 Micromonitor Software Memory Map.....	26
9.3 Connecting to Micromonitor.....	26
9.4 Micromonitor Commands.....	27
9.5 Getting More Information about Micromonitor.....	27
10 i.MXL LiteKit Schematics.....	28

List of Tables

Table 1 – CSB536FS Address Map.....	5
Table 2 – MC9328MXL Chip Select Assignments.....	8
Table 3 – MC9328MXL GPIO Port A Pin Assignments.....	9
Table 4 – MC9328MXL GPIO Port B Pin Assignments.....	10
Table 5 – MC9328MXL GPIO Port C Pin Assignments.....	11
Table 6 – MC9328MXL GPIO Port D Pin Assignments.....	12
Table 7 – CSB536FS/CSB925 Interrupt Pin Assignments.....	13
Table 8 – Compact Flash GPIO Assignments.....	14
Table 9 – Expansion Connector Mating Height Table.....	19
Table 10 – P1, Expansion Connector 1 Pinout.....	21
Table 11 – P2, Expansion Connector 2 Pinout.....	22
Table 12 – P3, Expansion Connector 3 Pinout.....	23

1 WARRANTY

The enclosed product ("the Product"), a part of the Cogent Modular Architecture or Cogent Single Board series, is warranted by Cogent Computer Systems, Inc. ("Cogent") for a period of six months for reasonable development testing and use, all as further described and defined below. This warranty runs solely to the individual or entity purchasing the Product and is not transferable or assignable in any respect. This warranty is valid only for so long as the product is used intact as shipped from Cogent. Any attempt or effort to alter the Product, including but not limited to any attempt to solder, desolder, unplug, replace, add or affix any part or component of or onto the Product, other than components specifically intended for the user to plug and unplug into appropriate sockets and/or connectors to facilitate user programming and development, all as specifically described and authorized in the Cogent Customer Product Users Manual, shall void this warranty in all respects. Coverage under this warranty requires that the Product be used and stored at all times in conditions with proper electrostatic protection necessary and appropriate for a complex electronic device. These conditions include proper temperature, humidity, radiation, atmosphere and voltage (standard commercial environment, 0C to +70C, <60%RH). Any Product that has been modified without the express, prior written consent of Cogent is not covered by this warranty. Cogent Single Board and Cogent Modular Architecture test and bus connectors are for use with Cogent adapters only. The use or connection of any test or bus connector, adapter or component with any device other than a Cogent connector or adapter shall void this warranty and the warranty of all other components, parts and modules connected to the rest of the system. Cogent shall not be responsible for any damage to the Product as a result of a customer's use or application of circuitry not developed or approved by Cogent for use on or in connection with the Product.

This warranty does not cover defects caused by electrical or temperature fluctuations or from stress resulting from or caused by abuse, misuse or misapplication of the Product. Any evidence of tampering with the serial number on the Product shall immediately void this warranty. This Product is not intended to be used on or embedded in or otherwise used in connection with any life sustaining or life saving product and this warranty is not applicable nor is Cogent liable in any respect if the Product is so used. Notwithstanding anything to the contrary herein, Cogent expressly disclaims any implied warranty of merchantability or implied warranty of fitness for a particular purpose in connection with the manufacture or use of the Product.

2 OVERVIEW

2.1 INTRODUCTION

The i.MXL LiteLiteKit (CSB536FS CPU Module along with the companion CSB935FS Breakout Board) was designed and developed by Cogent Computer Systems, Inc. as a highly integrated Freescale MC9328MXL Development LiteKit . The major features of the MC9328MXL Development LiteKit are as follows:

- 200Mhz Freescale MC9328MXL CPU with 16K I-Cache and 16K D-Cache
- 64Mbyte 32-Bit Wide SDRAM
- 8Mbyte 16-Bit Wide FLASH
- Ultra-Low Power CS8900a 10Mbit Ethernet Controller (on CSB935FS)
- 3.5” 240x320 QVGA TFT LCD with Integrated Touch Screen (on CSB935FS)
- RS-232 Buffer for Debug Serial Port (on CSB935FS)
- USB Device Interface (via USB Mini-B connector on CSB935FS)
- SD/MMC Controller (4-Bit) (socket on CSB935FS)
- Compact Flash Interface (socket and buffers on CSB935FS)
- Wolfson WM8731 Stereo Codec (on CSB935FS) with Line In, Line Out and Microphone In
- ADS7846E 4-Wire Touch Controller (on CSB935FS)
- On-Board Macraigor USBDemon JTAG Controller (via USB Mini-B on CSB536FS)
- Standard 20-Pin JTAG Header (on CSB935FS)

2.2 REFERENCE DOCUMENTS

Refer to the following documents for more detailed information regarding the major components of the i.MXL LiteKit . In all cases, you should contact the manufacturer for the latest documentation (including errata) regarding these components.

1. “Freescale® MC9328MXL i.MX Integrated Portable System Processor”, Reference Manual, MC9328MXLRM/D, Rev. 3.0 12/2003
2. “3V Intel StrataFLASH Memory” Datasheet, Order # 290667-006
3. Cirrus Logic “CS8900a Product Data Sheet”, Order Number DS271PP3
4. Wolfson Microelectronics WM8731/WM8731L “Portable Internet Audio Codec with Headphone Driver and Programmable Sample Rates”, Product Data Sheet, April 2004, Rev. 3.4
5. Texas Instruments ADS7846E “Touch Screen Controller”, Datasheet, SBAS125G, June 2003

3 ON BOARD DEVICES

3.1 CSB536FS ADDRESS MAP

The following table describes the Address Map of the i.MXL LiteKit . Refer to the MC9328MXL documentation for information regarding on-chip peripheral addressing.

CPU Chip Select	Chip Select Width	Wait States	Address Start	Address End	Description
*SDCS0	32	N/A	0x0800.0000	0x0BFF.FFFF	64Mbyte SDRAM
*CS0	16	10	0x1000.0000	0x11FF.FFFF	8Mbyte StrataFlash
*CS1	16	DTACK	0x2000.0000	0x21FF.FFFF	CS8900a Ethernet Controller
*CS2	-	-	-	-	Pin assigned to *SDCS0
*CS3	-	-	-	-	Not Available
*CS4	-	-	-	-	Not Available
*CS5	16	8	0x1400.0000	0x17FF.FFFF	Compact Flash Socket via CPLD

Table 1 – CSB536FS Address Map

3.2 8/16/32MBYTE STRATAFLASH

The i.MXL LiteKit uses an Intel StrataFlash 28F640 device (or equivalent) for boot memory. CS0 must be set to 16-bits width (this is the default on reset using hardware strapping) and 10 wait states (the default is 64 wait states after reset).

3.3 64MBYTE SDRAM

The i.MXL LiteKit uses two 16Mx16, PC100 or faster SDRAM devices for system memory. The specifications of these devices provides for 100Mhz operation. The maximum setting is 99.5Mhz allowing CAS Latency 2 and RAS to CAS 2 modes to be set. Refer to the MC9328MXL User Manual for more information on programming the SDRAM Memory Controller. Note that the default bus clock (and the only supported setting) is 46Mhz, set by the boot monitor.

3.4 CIRRUS LOGIC CS8900A ETHERNET CONTROLLER

The i.MXL LiteKit uses the CS8900a to provide a 10Mbit Ethernet Interface. This device is mapped to CPU Chip Select 1. In addition, the interrupt output of the CS8900a is connected to CPU GPIO PB17.

CS8900a Interface Notes:

1. The CS8900a is connected to *CS2 as a 16-bit wide device with 10 wait states minimum and DTACK enabled.
2. GPIO PB17 is connected to the CS8900a Interrupt output 0 (*IRQ0). The CS8900a Interrupt is a low true, level output.

3.5 ADS7846E 4-WIRE TOUCH CONTROLLER

The ADS7846E provides the i.MXL LiteKit with a 4-wire Touch Screen interface. The CPU communicates with the ADS7846E via the standard SPI bus.

ADS7846E Interface Notes:

1. The ADS7846E is connected the MC9328MXL using the built in SPI port.
2. GPIO PC15 is used as SPI Chip Select.
3. The ADS7846E interrupt output is connected to GPIO22. This interrupt output is a low true, level output.
4. Software is responsible for assigning the associated GPIO signals to SPI use. They are PC14 to PC17.

3.6 WOLFSON MICROELECTRONICS WM8731 I2S CODEC

The Wolfson WM8731 provides the i.MXL LiteKit with a 20-Bit Audio Codec. It supports Stereo Line in, Stereo Line out (which can also drive a headphone) and Microphone in

WM8731 Interface Notes:

1. GPIO PC3 to PC8 must be programmed for SSI Function, I2S Mode.
2. The WM8731 uses the I2C interface for control. GPIO PA16 (SDA) and PA16 (SCL) are used for this function. Note that they can be used as bit bang I2C or they may be programmed to the MC9328MXL I2C Controller function.

3.7 GPIO LED'S AND SWITCHES

Two Yellow LED's are located on the CSB536FS CPU Module along with two pushbutton switches. The LED's are assigned to GPIO PD31 (LED0) and PA1 (LED1), while the switches are assigned to PA3 (USR_SW0) and PA4 (USR_SW1). A low to the LED will turn the LED on. The switches will drive the associated GPIO low when pressed. Note that there is no de-bouncing in hardware for the switches.

3.8 I2C LED'S AND SWITCHES

A Phillips PCA9554 I2C GPIO Expander is provided to interface to four red LED's and four pushbutton switches on the CSB935FS. The I2C address of the PCA9554 is 0x20.

Refer to the schematic for the pin assignments. CPU GPIO PB19 will go low also whenever any one of the switches is pressed. As with the GPIO switches, there is no hardware de-bouncing circuitry.

3.9 3.5" QVGA TFT LCD WITH TOUCH

A 3.5" Portrait Mode QVGA LCD provides the i.MXL LiteKit with a low power, transfective LCD display with touch overlay, similar to that used on commercial PDA's. This allows the user to develop graphical user interfaces for a wide variety of end applications. Refer to the Micromonitor source code (mc9328mxl_lcd.c) for detailed programming and setup examples. Additionally, the schematic will show the necessary interface to this display.

4 MC9328MXL ON-CHIP I/O DEVICES

4.1 OVERVIEW

The MC9328MXL has a number of on-chip peripheral devices as well as a number of user defined control lines. While it is beyond the scope of this document to provide detailed programming and interfacing information for the MC9328MXL on-chip peripherals, the following section describes the assignments for these devices and control lines as implemented on the CSB536FS and on the CSB935FS breakout. Note that unused peripherals or GPIO are not made available on the CSB536FS connectors. They are simply unconnected.

4.2 MC9328MXL CHIP SELECTS

As described in Section 3.1, the MC9328MXL Chip Selects are used to enable the various peripheral devices on the i.MXL LiteKit . As a cross-reference they are described again in the following table.

Chip Select	Attached Device(s)	Notes
*CS0	StrataFLASH	Boot Device
*CS1	CS8900a	Ethernet Controller
*CS2	Used as *SDCS0	SDRAM
*CS3	Not Available	
*CS4	Not Available	
*CS5	Compact Flash	Via CPLD

Table 2 – MC9328MXL Chip Select Assignments

4.3 MC9328MXL GENERAL PURPOSE I/O PORT PIN ASSIGNMENTS

The MC9328MXL has four General Purpose I/O ports (A to D). The GPIO usage on the i.MXL LiteKit is described in the following tables. Note that it is the responsibility of software to setup these bits for the correct direction and default state as well as the assignment of alternate functions.

GPIO Port A			
Bit	DIR	Usage	Alternate Functions/Notes
PA1	Out	LED0	User LED on CSB536FS, 0 = on

GPIO Port A			
Bit	DIR	Usage	Alternate Functions/Notes
PA2	Out	GPIO/PWM0	LCD backlight, 1 = on, 0 = off
PA3	In	USR_SW0	User Switch 0 on CSB536FS, 0 = Pressed
PA4	In	USR_SW1	User Switch 1 on CSB536FS, 0 = Pressed
PA5	-	-	Not available
PA6	-	-	Not available
PA7	-	-	Not available
PA8	-	-	Not available
PA9	-	-	Not available
PA10	-	-	Not available
PA11	-	-	Not available
PA12	-	-	Not available
PA13	-	-	Not available
PA14	-	-	Not available
PA15	I/O	SDA	I2C Data
PA16	I/O	SCL	I2C Clock
PA17	In	DTACK	Used by CS8900a and Compact Flash
PA18	-	-	Not available
PA19	-	-	Not available
PA20	-	-	Not available
PA21	Out	A0	Used as CPU A0
PA22	-	-	Not available
PA23	Out	*CS5	Chip Select for Compact Flash

Table 3 – MC9328MXL GPIO Port A Pin Assignments

GPIO Port B			
Bit	DIR	Usage	Alternate Functions/Notes
PB8	I/O	SD_D0	SD/MMC Interface Data Bit 0
PB9	I/O	SD_D1	SD/MMC Interface Data Bit 1

GPIO Port B			
Bit	DIR	Usage	Alternate Functions/Notes
PB10	I/O	SD_D2	SD/MMC Interface Data Bit 2
PB11	I/O	SD_D3	SD/MMC Interface Data Bit 3
PB12	Out	SD_CMD	SD/MMC Interface Command Bit
PB13	Out	SD_CLK	SD/MMC Interface Clock Bit
PB14	Out	SD_VEN	SD/MMC Power Enable, 1 = on
PB15	In	SD_WP	SD/MMC Write Protect, 0 = Protected
PB16	In	*SD_CD	SD/MMC Card Detect, 0 = Card Present
PB17	In	*E_INT	CS8900a Interrupt, 0 = active
PB18	In	*PIRQ	ADS7846E Touch Controller Interrupt, 0 = active
PB19	In	*I2C_INT	PCA9554 GPIO Expander Interrupt, 0 = active
PB20	-	-	Not available
PB21	Out	*USB_D_OE	Transmit Output Enable to USB Transceiver
PB22	-	-	Not available
PB23	Out	USB_SUSP	Suspend to USB Transceiver
PB24	Out	USB_VP	USB Receive + from USB Transceiver
PB25	Out	USB_VM	USB Receive - from USB Transceiver
PB26	Out	USB_VPO	USB Transmit + to USB Transceiver
PB27	Out	USB_VPM	USB Transmit - to USB Transceiver
PB28	Out	USB_SPD	1 = 12Mbit, 0 = 1Mbit
PB29	Out	USB_MODE	1 = Differential, 0 = Single Ended
PB30	Out	USB_EN	1 = Enable, 0 = Disable USB Transceiver
PB31	-	-	Not available

Table 4 – MC9328MXL GPIO Port B Pin Assignments

GPIO Port C			
Bit	DIR	Usage	Alternate Functions/Notes

GPIO Port C			
Bit	DIR	Usage	Alternate Functions/Notes
PC3	Out	SSI_RFS	Receive Frame Sync to I2S Codec
PC4	In	SSI_CLK	Audio Bit Clock from I2S Codec
PC5	In	SSI_RXD	Receive Audio Data from I2S Codec
PC6	Out	SSI_TXD	Transmit Audio Data to I2S Codec
PC7	Out	SSI_TFS	Transmit Frame Sync to I2S Codec
PC8	Out	LCD_VEN	LCD Power Enable, 1 = on
PC9	In	USB_CD	1 = USB Cable powered on
PC10	Out	USB_SCON	1 = Indicate to the Host a 12Mbit USB Device (the MC9328MXL) is present (leave as input when not ready to connect)
PC11	Out	U1_TXD	Debug Port Transmit via RS232 buffer
PC12	In	U1_RXD	Debug Port Receive via RS232 buffer
PC13	-	-	Not available
PC14	Out	SPI_CLK	SPI Clock to ADS7846E
PC15	Out	SPI_CS	SPI Chip Select (low true) to ADS7846E
PC16	In	SPI_DIN	SPI Data In from ADS7846E
PC17	Out	SPI_DOUT	SPI Data Out to ADS7846E

Table 5 – MC9328MXL GPIO Port C Pin Assignments

GPIO Port D			
Bit	DIR	Usage	Alternate Functions/Notes
PD6	Out	LCD_PCLK	LCD Pixel Clock
PD7	In	*CF_CD	Compact Flash Card Detect, 0 = Present
PD8	Out	CF_RST	Compact Flash Reset, 1= Reset Card
PD9	In	CF_RDY	Compact Flash Ready/Busy Status Flag
PD10	Out	CF_VEN	Compact Flash Power Enable, 1 = on
PD11	Out	LCD_CONT	LCD Auxiliary Voltages Enable, 1 = on
PD12	Out	LCD_DOE	LCD Output Enable in TFT Mode

GPIO Port D			
Bit	DIR	Usage	Alternate Functions/Notes
PD13	Out	LCD_HSYNC	LCD Horizontal Sync
PD14	Out	LCD_VSYNC	LCD Vertical Sync
PD15	Out	LCD_B1	LCD Blue Bit 1 (LSB)
PD16	Out	LCD_B2	LCD Blue Bit 2
PD17	Out	LCD_B3	LCD Blue Bit 3
PD18	Out	LCD_B4	LCD Blue Bit 4
PD19	Out	LCD_B5	LCD Blue Bit 5 (MSB)
PD20	Out	LCD_G0	LCD Green Bit 0 (LSB)
PD21	Out	LCD_G1	LCD Green Bit 1
PD22	Out	LCD_G2	LCD Green Bit 2
PD23	Out	LCD_G3	LCD Green Bit 3
PD24	Out	LCD_G4	LCD Green Bit 4
PD25	Out	LCD_G5	LCD Green Bit 5 (MSB)
PD26	Out	LCD_R1	LCD Red Bit 1 (LSB)
PD27	Out	LCD_R2	LCD Red Bit 2
PD28	Out	LCD_R3	LCD Red Bit 3
PD29	Out	LCD_R4	LCD Red Bit 4
PD30	Out	LCD_R5	LCD Red Bit 5 (MSB)
PD31	Out	*LED0	User LED 0 on CSB536FS, 0 = on

Table 6 – MC9328MXL GPIO Port D Pin Assignments

4.4 MC9328MXL INTERRUPT PIN ASSIGNMENTS

The MC9328MXL has a number of GPIO's that are, or can be used as interrupt inputs to the ARM9 Interrupt Controller. The following table describes the GPIO that are used as interrupts on the i.MXL LiteKit . User software is required to enable the interrupt function for any signal.

GPIO Bit	Source	Notes
PA3	*USR_SW0	User Pushbutton Switch 0

GPIO Bit	Source	Notes
PA4	*USR_SW1	User Pushbutton Switch 1
PB16	*SD_CD	SD/MMC Card Detect (0 = card in)
PB17	*E_INT	CS8900a Interrupt, 0 = active
PB18	*PIRQ	ADS7846E Touch Controller Interrupt, 0 = active
PB19	*I2C_INT	PCA9554 GPIO Expander Interrupt, 0 = active
PC9	*USB_CD	USB Cable Detect (1 = USB Device Cable In and powered)
PD7	*CF_CD	CF Card Detect (0 = card in)
PD9	CF_RDY	CF Ready/Busy – Polarity depends upon the mode the CF card is in.

Table 7 – CSB536FS/CSB925 Interrupt Pin Assignments

4.5 MC9328MXL DEBUG UART

The MC9328MXL UART 1 is used as the debug UART on the i.MXL LiteKit . This UART is buffered with an RS-232 Transceiver (TXD and RXD only) and brought to the DB-9. Software must assign the appropriate GPIO pins (PC11 = TXD, PC12 = RXD) to the UART 1 function. Refer to the MC9328MXL Users Manual for more information about the MC9328MXL UARTS.

4.6 MC9328MXL SPI CONTROLLER

The MC9328MXL provides a high-speed, Serial Peripheral Interface (SPI) controller. This port is used to interface with the ADS7846E Touch Controller. Refer to the MC9328MXL Users Manual for detailed programming information.

4.7 MC9328MXL I2C INTERFACE

The MC9328MXL has a full speed (100Khz/400Khz), master/slave I2C Serial Controller. The controller is fully compatible with the industry standard I2C and SMBus Interfaces. For simplicity, the I2C pins may also be programmed as GPIO (PA15 = SDA, PA16 = SCL). This allows simple “Bit Banging” control of I2C peripherals without setting up the MC9328MXL I2C Controller

4.8 MC9328MXL 4-BIT SD/MMC CONTROLLER

The MC9328MXL has a high-speed 4-Bit Secure Digital (SD/MMC) controller. This controller can interface with MMC, SD and SDIO Cards with minimal host intervention. The internal MC9328MXL DMA controller can be used to transfer data between the SD/MMC Socket on the i.MXL LiteKit and system memory for very high data rates. The

SD/MMC clock can be programmed up to 20Mhz. On the i.MXL LiteKit two GPIO's are used to indicate SD Card Detect (GPIO PB16, 0 = card inserted) and SD Write Protect (GPIO PB15, 0 = Write Protected). Additionally, GPIO PB14 controls power to the socket. When 1, power is driven to the SD/MMC socket. A 0 disables the socket. Refer to the MC9328MXL Users Manual for detailed programming information on the SD/MMC Controller.

4.9 MC9328MXL COMPACT FLASH

The MC9328MXL supports the Compact Flash using a CPLD to generate the proper timing signals. On the i.MXL LiteKit , several GPIO's are used to support the Compact Flash. They are shown in the following table.

GPIO	Source	Notes
PD9	CSB925 - CF RDY/BSY	Polarity depends upon the mode the Compact Flash card is in
PD10	CSB925 – CF Power Enable	1 = On
PD7	CSB925 - CF Card Detect	0 = Card Present
PD8	CSB925 – CF Reset	High True

Table 8 – Compact Flash GPIO Assignments

4.10 MC9328MXL USB DEVICE PORT

The MC9328MXL has a single, USB1.1 compliant Device Port. An on-board USB Transceiver provides the physical interface. In addition, two GPIO's are used for host notification and host detect. GPIO PC10 drives the USB D+ line via a 1.5K-ohm resistor. When the USB device port is connected to a USB host, software can indicate to the host that a device is present by driving GPIO Port C10 high. This indicates to the host both the presence of a USB device and that the device is 12Mbit capable. This also allows the MC9328MXL USB Device software to delay recognition by the Host until it is ready. Also, GPIO PC9 goes high when the USB device port is connected to, and powered from, a USB Host. This allows the USB device software to recognize when it is actually connected to a host. Refer to the MC9328MXL Users Manual for detailed programming information.

4.11 TFT LCD CONTROLLER

The MC9328MXL contains a built in LCD controller. On the i.MXL LiteKit , this is connected to the 3.5" 240x320 LCD. It is beyond the scope of this document to provide complete programming information. Please refer to the Micromonitor source code for an example of how to initialize and setup the LCD controller for the 3.5" LCD. Refer to

the MC9328MXL Users Manual for more detailed information.

There are 3 GPIO's used in the interface to the 3.5" (or other) LCD. GPIO PA2 is used as the backlight control. A 1 will enable the LED backlight contained in the LCD, while a 0 will shut it off. Note that the alternate function of GPIO PA2 is PWM0 (Pulse Width Modulator 0). This allows the LED backlight intensity to be varied from full on to full off. GPIO PD11 controls the auxiliary voltages (+12V and -6.5V), if any. Again, a one will enable them while a 0 will turn them off. The control for the auxiliary voltages is separate from the main voltages due the power-sequencing requirement of the LCD panel. Again, refer to the Micromonitor source code for an example of this.

5 POWER AND JTAG

5.1 OVERVIEW

The i.MXL LiteKit has a high efficiency 3.3V-switching regulator located on the CPU Module (CSB5365FS). Additionally the module can be powered in stand-alone mode via the USBDemon connector on the CPU Module.

5.2 3.3V SWITCHING REGULATOR

On board the CSB536FS is a high efficiency (90%+), high power, switching regulator. It is designed to accept a wide input voltage range of +5V to +15V. It produces 4.5 Amps of current, of which a minimum of 3 Amps is available to the CSB935FS breakout board.

3.3V Regulator Notes:

1. The optimal input voltage range for the regulator is 12V +/- 2V, which achieves an efficiency of 90%+. Otherwise the efficiency drops to approximately 80%.
2. When powered in stand-alone mode from the USBDemon connector, the regulator is provided with 5V +/- 10%. In this mode the maximum output current is limited by the input power of $\sim 2.4W \times 80\% = 3.3V @ 580ma$.
3. Power in stand-alone or in LiteKit mode is provided via the 1.3mm power jack on the CPU Module. Input voltage should be limited to +5V to +15V. Although the input can be unregulated it must be DC.
4. The USBDemon circuitry uses a low drop out (LDO) regulator to power from the input voltage. The current draw is $\sim 50ma$. At the maximum voltage (15V), the LDO dissipates 500mw which is it's maximum.

5.3 MACRAIGOR USBDEMON

On board the CPU Module is the Macraigor USBDemon JTAG interface. A USB Mini-B type connector is used to interface the USBDemon to the Host computer. Refer to the USBDemon Users Manual for detailed information on using the USBDemon JTAG interface.

Note that the i.MXL LiteKit contains a standard 20-pin JTAG header on the breakout board as well. This may be used instead of the USBDemon interface. In that case, DO NOT CONNECT the USBDemon cable and an external JTAG controller to the 20-Pin header simultaneously.

6 CSB536FS SOFTWARE

6.1 OVERVIEW

Due to the various resources contained on the CSB536FS (and CSB925), both on and off the MC9328MXL, it is necessary to initialize a large number of MC9328MXL registers and external devices before correct operation can begin. These values and their proper sequencing are beyond the scope of this document. The Micromonitor source code should be referred to as the best guide.

7 CSB536FS CPU MODULE CONNECTORS, LED'S AND SWITCHES

7.1 OVERVIEW

This section provides the locations and pinouts of the various connectors on the i.MXL LiteKit CPU Module.

7.2 CSB536FS EXPANSION CONNECTOR

The following diagram shows the location of the Expansion Connectors and the mounting holes on the CSB536FS. The mounting holes are .100" in diameter.

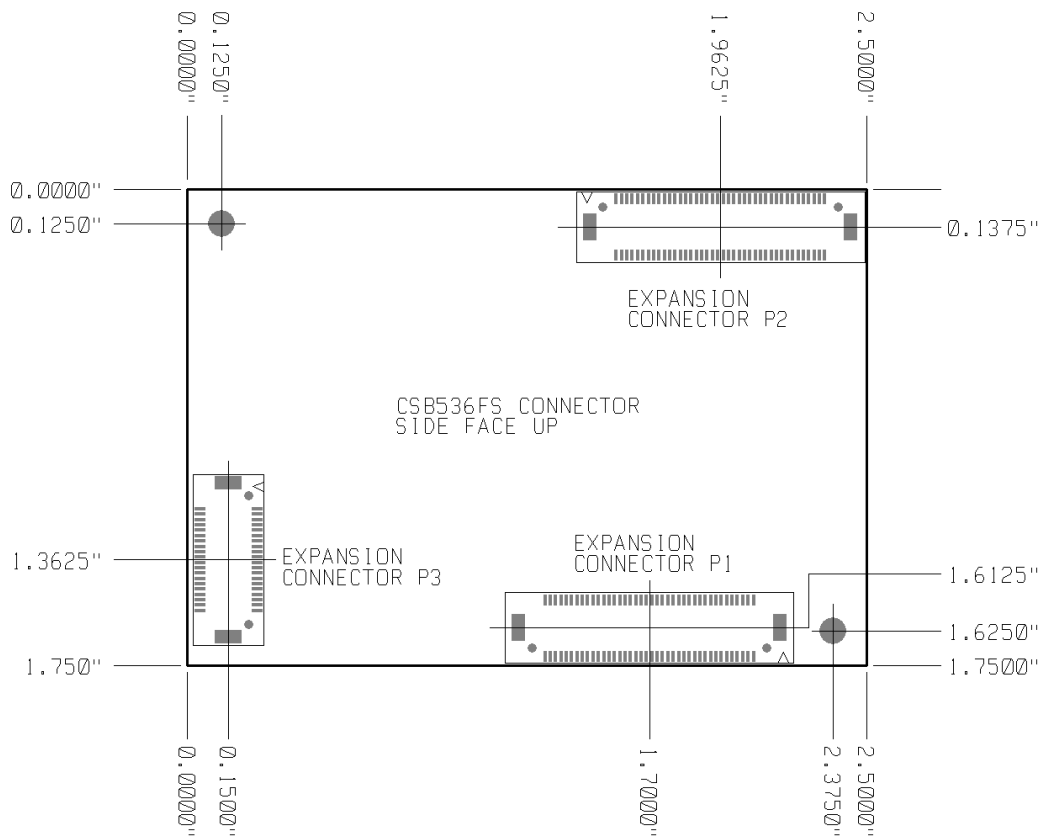

7.3 CSB536FS EXPANSION CONNECTORS

P1 and P2 are 80-Pin, low profile, SMT connectors, Hirose part number DF17(3.0)-80DS-0.5V. P3 is 40-Pin, low profile, SMT connector, Hirose part number DF17(3.0)-40DS-0.5V. There are two mating connector heights that can be placed on the target board. They result in the following board-to-board and overall heights (the CSB935FS uses the 4.0):

Mating Connector (xx = 40 or 80)	Board-Board Height	Overall Height	Component Clearance
DF17(2.0)-xxDP-0.5V	5.0mm	9.0mm	1.0mm
DF17(4.0)-xxDP-0.5V	7.0mm	11.0mm	3.0mm

Table 9 - Expansion Connector Mating Height Table

The orientation of the Target board connectors is shown in the following drawing. The “V” in the silkscreen indicates Pin 1. 80-Pin size is shown.

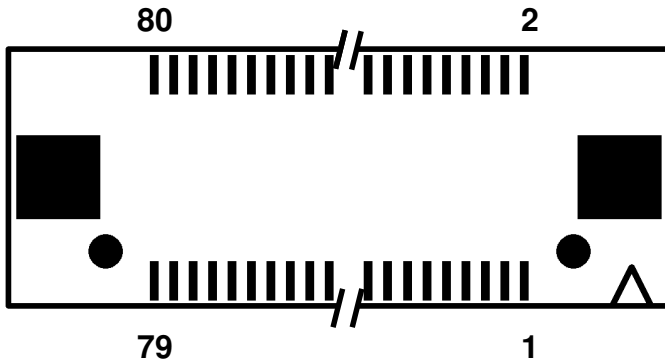

7.4 CSB536FS EXPANSION CONNECTOR PINOUTS

The following tables describe the pinouts of the four expansion connectors. The signal name shown is the MC9328MXL signal name unless otherwise indicated.

Expansion Connector P1			
Pin	Signal	Pin	Signal
1	Ground	2	Ground
3	Ground	4	Ground
5	Ground	6	Ground
7	Ground	8	Ground
9	USB D-	10	-
11	USB D+	12	-

Expansion Connector P1			
Pin	Signal	Pin	Signal
13	Ground	14	Ground
15	Ground	16	I2C_SCL
17	SPI_DIN	18	I2S_TXD
19	SD_VEN	20	I2C_SDA
21	-	22	Ground
23	Ground	24	I2S_BCLK
25	LCD_VEN	26	Ground
27	Ground	28	I2S_TFS
29	I2S_RXD	30	*SD_CD
31	-	32	LCD_DOE
33	SSI_RFS	34	LCD_CONT
35	Ground	36	LCD_HSYNC
37	SPI_CLK	38	CF_RDY
39	Ground	40	*CF_CD
41	UART1_RXD	42	LCD_R4
43	-	44	LCD_R1
45	-	46	LCD_R2
47	LCD_VSYNC	48	LCD_G0
49	LCD_G5	50	LCD_G4
51	LCD_G1	52	LCD_G2
53	LCD_R3	54	LCD_B2
55	CF_RST	56	LCD_B4
57	LCD_R5	58	LCD_B3
59	CF_VEN	60	LCD_B1
61	Ground	62	LCD_G3
63	LCD_PCLK	64	LCD_B5
65	Ground	66	CPU ADDRESS 20
67	CPU ADDRESS 19	68	CPU ADDRESS 18

Expansion Connector P1			
Pin	Signal	Pin	Signal
69	CPU ADDRESS 17	70	CPU ADDRESS 16
71	CPU ADDRESS 14	72	CPU ADDRESS 15
73	+3.3V	74	+3.3V
75	+3.3V	76	+3.3V
77	+3.3V	78	+3.3V
79	+3.3V	80	+3.3V

Table 10 – P1, Expansion Connector 1 Pinout

Expansion Connector P2			
Pin	Signal	Pin	Signal
1	Ground	2	Ground
3	Ground	4	Ground
5	Ground	6	Ground
7	Ground	8	Ground
9	CPU CLKOUT	10	-
11	Ground	12	CPU ADDRESS 9
13	CPU ADDRESS 13	14	CPU ADDRESS 10
15	CPU ADDRESS 11	16	CPU ADDRESS 7
17	CPU ADDRESS 12	18	CPU ADDRESS 8
19	CPU DATA 15	20	CPU ADDRESS 5
21	CPU DATA 14	22	CPU ADDRESS 6
23	CPU DATA 13	24	CPU DATA 11
25	CPU ADDRESS 3	26	*EB1
27	CPU ADDRESS 4	28	CPU ADDRESS 2
29	CPU DATA 12	30	*EB0
31	*EB3	32	CPU DATA 7
33	*EB2	34	CPU DATA 9
35	*OE	36	CPU ADDRESS 1

Expansion Connector P2			
Pin	Signal	Pin	Signal
37	CPU DATA 10	38	CPU DATA 8
39	*DTACK	40	*CS5
41	*CS3	42	CPU ADDRESS 0
43	CPU DATA 6	44	CPU DATA 5
45	*CS1	46	CPU DATA 4
47	CPU DATA 3	48	*CS0
49	CPU DATA 0	50	CPU DATA 2
51	CPU DATA 1	52	R/*W
53	Ground	54	Ground
55	SD_CMD	56	SD_CLK
57	Ground	58	Ground
59	SD_D2	60	SD_D3
61	SD_D0	62	SD_D1
63	USB_CD	64	USB_SCON
65	UART1 TXD	66	*PIRQ (ADS7846E)
67	E_INT (CS8900a)	68	PWM0 (LED_BKL)
69	SPI_DOUT	70	SPI_CS
71	*I2C_INT (PCA9554)	72	SD_WP
73	+3.3V	74	+3.3V
75	+3.3V	76	+3.3V
77	+3.3V	78	+3.3V
79	+3.3V	80	+3.3V

Table 11 – P2, Expansion Connector 2 Pinout

Expansion Connector P3			
Pin	Signal	Pin	Signal
1	Ground	2	VIN
3	Ground	4	VIN

Expansion Connector P3			
Pin	Signal	Pin	Signal
5	Ground	6	VIN
7	Ground	8	VIN
9	*RST_IN	10	VIN
11	*TSRT	12	VIN
13	-	14	VIN
15	TCK	16	Ground
17	TMS	18	Ground
19	TDI	20	Ground
21	TDO	22	Ground
23	*RST_OUT	24	Ground
25	BSEL0	26	Ground
27	BSEL1	28	VMAIN
29	BSEL2	30	VMAIN
31	BSEL3	32	VMAIN
33	Ground	34	VMAIN
35	Ground	36	VMAIN
37	Ground	38	VMAIN
39	Ground	40	VMAIN

Table 12 – P3, Expansion Connector 3 Pinout

7.5 CSB536FS TOPSIDE CONNECTORS, LED'S AND SWITCHES

The following diagram shows the location of the connectors, LED's and Switches on the CSB536FS CPU Module.

8 CSB935FS BREAKOUT BOARD CONNECTORS, LED'S AND SWITCHES

8.1 OVERVIEW

This section provides the locations and pinouts of the various connectors on the i.MXL LiteKit CPU Module.

8.2 CSB935FS CONNECTORS, LED'S AND SWITCHES - TOPSIDE

The following diagram shows the location of the Connectors, LED's and Switches on the CSB935FS topside.

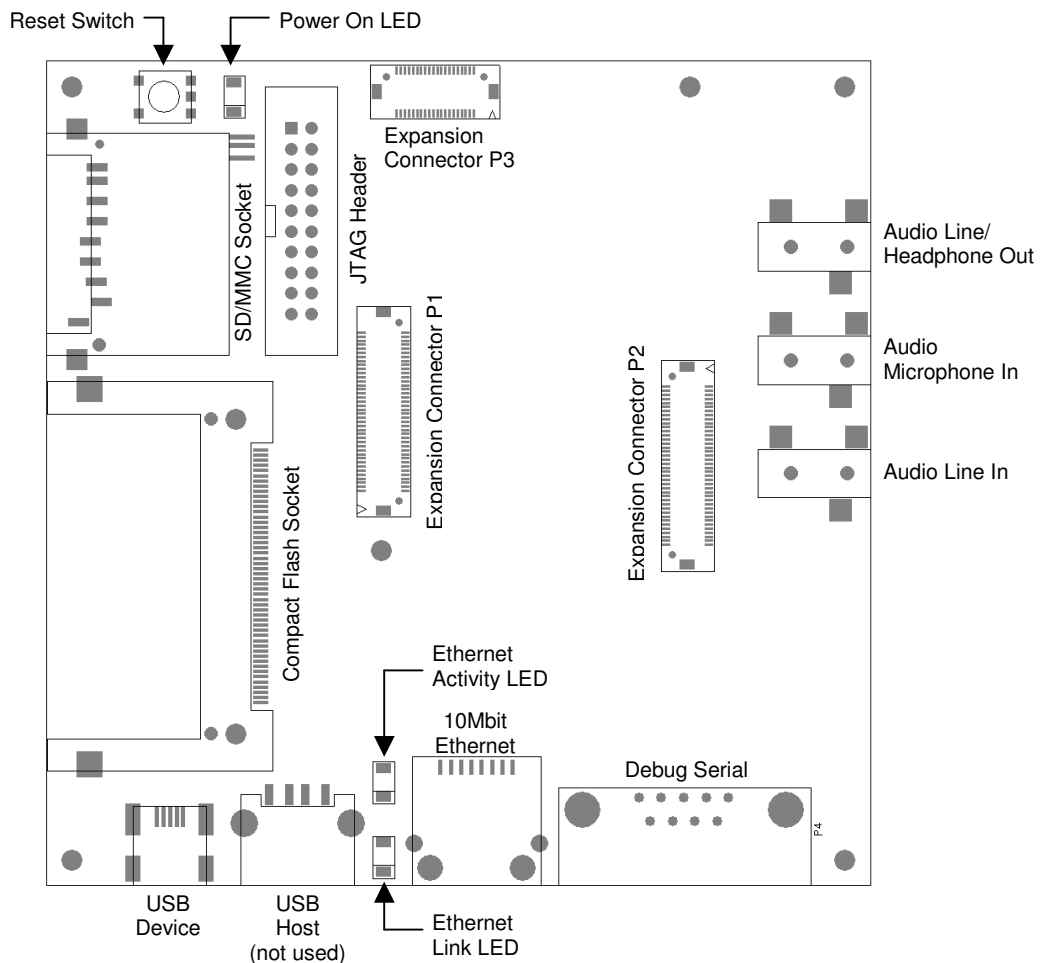

8.3 CSB935FS CONNECTORS, LED'S AND SWITCHES – BACKSIDE

The following diagram shows the location of the Connectors, LED's and Switches on the CSB935FS backside.

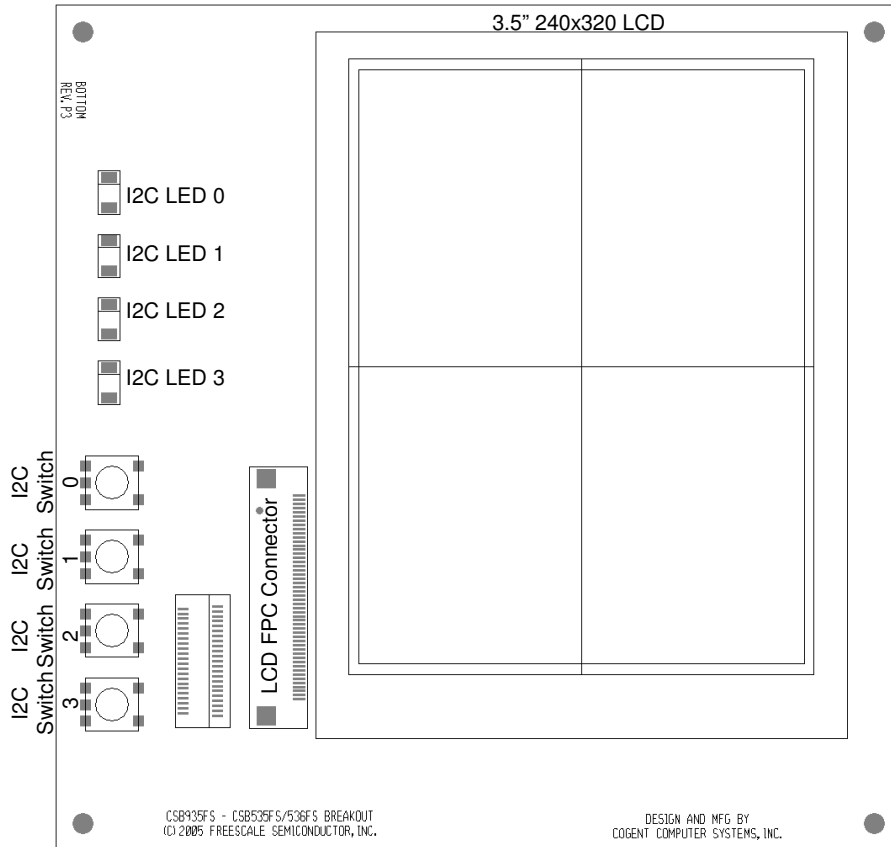

9 MICROMONITOR

9.1 INTRODUCTION TO MICROMONITOR

The i.MXL LiteKit is delivered standard with the Micromonitor boot monitor in FLASH. Micromonitor was developed and is maintained by Ed Sutter of Lucent Technologies. Micromonitor is an open source product and may be copied, modified and re-used without restriction. However, neither Cogent nor Lucent is liable for any problems that may arise during the use of Micromonitor including its use with this board.

9.2 MICROMONITOR SOFTWARE MEMORY MAP

The memory usage by Micromonitor is shown in the following block diagram:

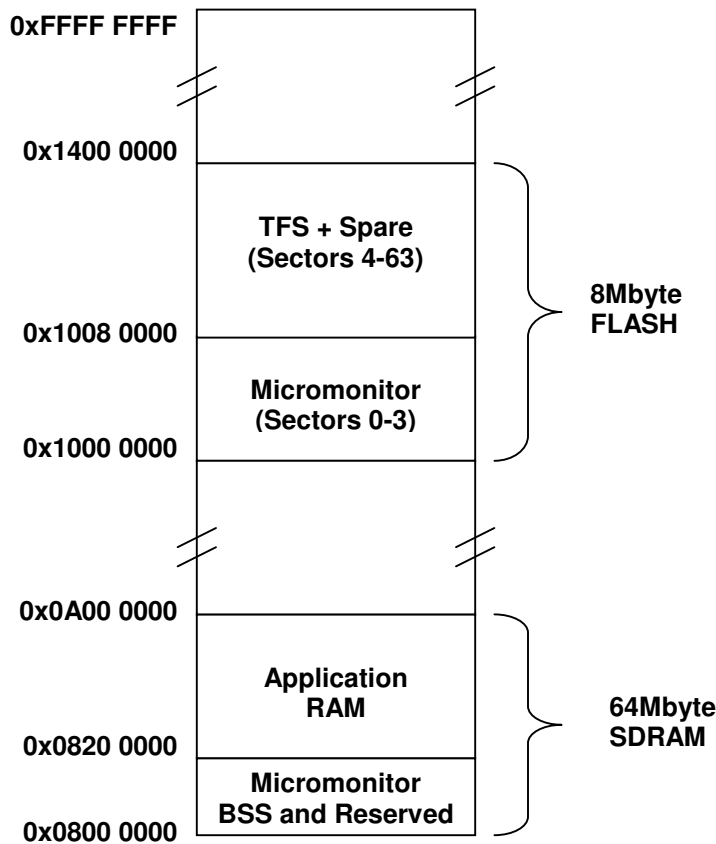

Note: All addresses shown are physical addresses.

9.3 CONNECTING TO MICROMONITOR

As delivered from Cogent, Micromonitor is configured to use the Debug UART (MC9328MXL UART 1). The default connection is 38,400 baud, 8-N-1, with no handshaking. A null modem cable is provided with the i.MXL LiteKit that will connect

the CSB536FS to another DTE port such as found on a PC.

Micromonitor also uses the Ethernet port to listen for connections via UDP.

9.4 MICROMONITOR COMMANDS

Micromonitor supports a wide variety of commands that allow the user to modify and/or read memory, download programs from Ethernet, Serial or on-board Flash File System (TFS) and many others. Refer to the Micromonitor Users Manual for a complete listing. Note that not all commands are available on all targets. Type the following command (assuming you are connected using a standard terminal program) at the Micromonitor command prompt to get a list of the commands currently enabled on your target:

```
umon> help
```

The terminal window will then display the commands installed on your target. Additional help for each command can be displayed by typing “help xxx” where “xxx is the specific command you are seeking help on.

You can also type the following to get information regarding the build date, memory usage, default application load address (APPRAMBASE) and other useful information regarding Micromonitor as installed on your i.MXL LiteKit :

```
uMon> mstat
```

9.5 GETTING MORE INFORMATION ABOUT MICROMONITOR

Micromonitor reference information and a more advanced Micromonitor training guide are available from Microcross, Inc. (www.microcross.com).

10 I.MXL LITEKIT SCHEMATICS



Стандарт Электрон Связь

Мы молодая и активно развивающаяся компания в области поставок электронных компонентов. Мы поставляем электронные компоненты отечественного и импортного производства напрямую от производителей и с крупнейших складов мира.

Благодаря сотрудничеству с мировыми поставщиками мы осуществляем комплексные и плановые поставки широчайшего спектра электронных компонентов.

Собственная эффективная логистика и склад в обеспечивает надежную поставку продукции в точно указанные сроки по всей России.

Мы осуществляем техническую поддержку нашим клиентам и предпродажную проверку качества продукции. На все поставляемые продукты мы предоставляем гарантию .

Осуществляем поставки продукции под контролем ВП МО РФ на предприятия военно-промышленного комплекса России , а также работаем в рамках 275 ФЗ с открытием отдельных счетов в уполномоченном банке. Система менеджмента качества компании соответствует требованиям ГОСТ ISO 9001.

Минимальные сроки поставки, гибкие цены, неограниченный ассортимент и индивидуальный подход к клиентам являются основой для выстраивания долгосрочного и эффективного сотрудничества с предприятиями радиоэлектронной промышленности, предприятиями ВПК и научно-исследовательскими институтами России.

С нами вы становитесь еще успешнее!

Наши контакты:

Телефон: +7 812 627 14 35

Электронная почта: sales@st-electron.ru

Адрес: 198099, Санкт-Петербург,
Промышленная ул, дом № 19, литера Н,
помещение 100-Н Офис 331