



STD95N2LH5 STP95N2LH5, STU95N2LH5

N-channel 25 V, 0.0038 Ω , 80 A, DPAK, IPAK, TO-220
STripFET™ V Power MOSFET

Features

Type	V _{DSS}	R _{DS(on)} max	I _D
STD95N2LH5	25 V	< 0.0045 Ω	80 A
STP95N2LH5	25 V	< 0.0049 Ω	80 A
STU95N2LH5	25 V	< 0.0049 Ω	80 A

- R_{DS(on)} * Q_g industry benchmark
- Extremely low on-resistance R_{DS(on)}
- High avalanche ruggedness
- Low gate drive power losses

Application

- Switching applications

Description

This STripFET™V Power MOSFET technology is among the latest improvements, which have been especially tailored to achieve very low on-state resistance providing also one of the best-in-class FOM (figure of merit).

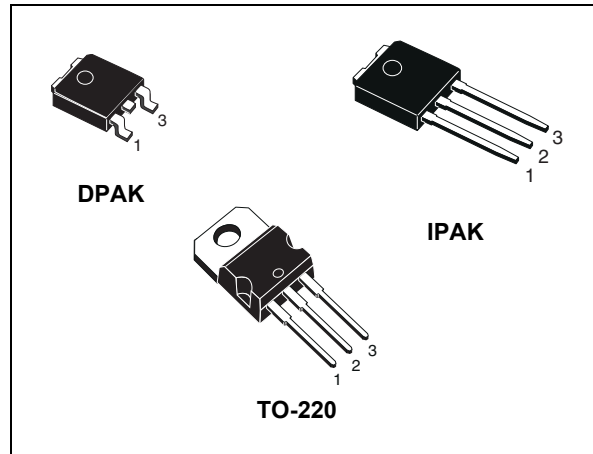

Figure 1. Internal schematic diagram

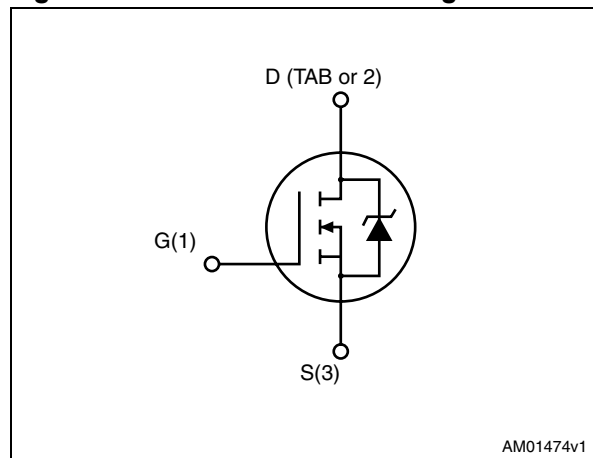

Table 1. Device summary

Order codes	Marking	Package	Packaging
STD95N2LH5	95N2LH5	DPAK	Tape and reel
STP95N2LH5	95N2LH5	TO-220	Tube
STU95N2LH5	95N2LH5	IPAK	Tube

Contents

1	Electrical ratings	3
2	Electrical characteristics	4
2.1	Electrical characteristics (curves)	6
3	Test circuits	9
4	Package mechanical data	11
5	Packaging mechanical data	15
6	Revision history	16

1 Electrical ratings

Table 2. Absolute maximum ratings

Symbol	Parameter	Value		Unit
		DPAK/IPAK	TO-220	
V_{DS}	Drain-source voltage ($V_{GS}=0$)	25		V
V_{GS}	Gate-Source voltage	± 22		V
$I_D^{(1)}$	Drain current (continuous) at $T_C = 25^\circ\text{C}$	80	95	A
I_D	Drain current (continuous) at $T_C = 100^\circ\text{C}$	67		A
$I_{DM}^{(2)}$	Drain current (pulsed)	320	380	A
P_{TOT}	Total dissipation at $T_C = 25^\circ\text{C}$	70	80	W
	Derating factor	0.47		W/ $^\circ\text{C}$
$E_{AS}^{(3)}$	Single pulse avalanche energy	165		mJ
T_j T_{stg}	Operating junction temperature Storage temperature	-55 to 175		$^\circ\text{C}$

1. Limited by wire bonding
2. Pulse width limited by safe operating area
3. Starting $T_j = 25^\circ\text{C}$, $I_d = 40\text{ A}$, $V_{dd} = 20\text{ V}$

Table 3. Thermal resistance

Symbol	Parameter	Value	Unit
$R_{thj-case}$	Thermal resistance junction-case max	2.14	$^\circ\text{C}/\text{W}$
$R_{thj-amb}$	Thermal resistance junction-case max	100	$^\circ\text{C}/\text{W}$
T_j	Maximum lead temperature for soldering purpose	275	$^\circ\text{C}$

2 Electrical characteristics

($T_{CASE}=25\text{ °C}$ unless otherwise specified)

Table 4. Static

Symbol	Parameter	Test conditions	Min.	Typ.	Max.	Unit
$V_{(BR)DSS}$	Drain-source breakdown Voltage	$I_D = 250\ \mu\text{A}$, $V_{GS} = 0$	25			V
I_{DSS}	Zero gate voltage drain current ($V_{GS} = 0$)	$V_{DS} = 25\text{ V}$ $V_{DS} = 25\text{ V}$, $T_c = 125\text{ °C}$			1 10	μA μA
I_{GSS}	Gate body leakage current ($V_{DS} = 0$)	$V_{GS} = \pm 22\text{ V}$			± 100	nA
$V_{GS(th)}$	Gate threshold voltage	$V_{DS} = V_{GS}$, $I_D = 250\ \mu\text{A}$	1			V
$R_{DS(on)}$	Static drain-source on resistance	$V_{GS} = 10\text{ V}$, $I_D = 40\text{ A}$ SMD version		0.0038	0.0045	Ω
		$V_{GS} = 10\text{ V}$, $I_D = 40\text{ A}$		0.0044	0.0049	Ω
		$V_{GS} = 5\text{ V}$, $I_D = 40\text{ A}$ SMD version		0.005	0.006	Ω
		$V_{GS} = 5\text{ V}$, $I_D = 40\text{ A}$		0.006	0.007	Ω

Table 5. Dynamic

Symbol	Parameter	Test conditions	Min.	Typ.	Max.	Unit
C_{iss}	Input capacitance	$V_{DS} = 25\text{ V}$, $f = 1\text{ MHz}$, $V_{GS} = 0$	-	1817	-	pF
C_{oss}	Output capacitance			420		pF
C_{rss}	Reverse transfer capacitance			67		pF
Q_g	Total gate charge	$V_{DD} = 13\text{ V}$, $I_D = 80\text{ A}$	-	13.4	-	nC
Q_{gs}	Gate-source charge	$V_{GS} = 5\text{ V}$		6.7		nC
Q_{gd}	Gate-drain charge	Figure 18		4.1		nC
Q_{gs1}	Pre V_{th} gate-to-source charge	$V_{DD} = 13\text{ V}$, $I_D = 80\text{ A}$ Figure 21	-	3.5	-	nC
Q_{gs2}	Post V_{th} gate-to-source charge			3.2		nC
R_G	Gate input resistance	f=1 MHz gate bias Bias= 0 test signal level=20 mV open drain	-	1.1	-	Ω

Table 6. Switching on/off (inductive load)

Symbol	Parameter	Test conditions	Min.	Typ.	Max.	Unit
$t_{d(on)}$ t_r	Turn-on delay time Rise time	$V_{DD}=12.5\text{ V}$, $I_D=40\text{ A}$, $R_G=4.7\ \Omega$, $V_{GS}=10\text{ V}$ Figure 17	-	7 38	-	ns ns
$t_{d(off)}$ t_f	Turn-off delay time Fall time	$V_{DD}=12.5\text{ V}$, $I_D=40\text{ A}$, $R_G=4.7\ \Omega$, $V_{GS}=10\text{ V}$ Figure 17	-	22 7	-	ns ns

Table 7. Source drain diode

Symbol	Parameter	Test conditions	Min.	Typ.	Max.	Unit
I_{SD}	Source-drain current		-		80	A
$I_{SDM}^{(1)}$	Source-drain current (pulsed)		-		320	A
$V_{SD}^{(2)}$	Forward on voltage	$I_{SD}=35\text{ A}$, $V_{GS}=0$	-		1.1	V
t_{rr}	Reverse recovery time	$I_{SD}=80\text{ A}$, $V_{DD}=20\text{ V}$	-	32.4		ns
Q_{rr}	Reverse recovery charge	$di/dt=100\text{ A}/\mu\text{s}$,	-	27.1		nC
I_{RRM}	Reverse recovery current	Figure 19	-	1.7		A

1. Pulse width limited by safe operating area
2. Pulsed: pulse duration = 300 μs , duty cycle 1.5%

2.1 Electrical characteristics (curves)

Figure 2. Safe operating area for DPAK, IPAK Figure 3. Thermal impedance for DPAK, IPAK

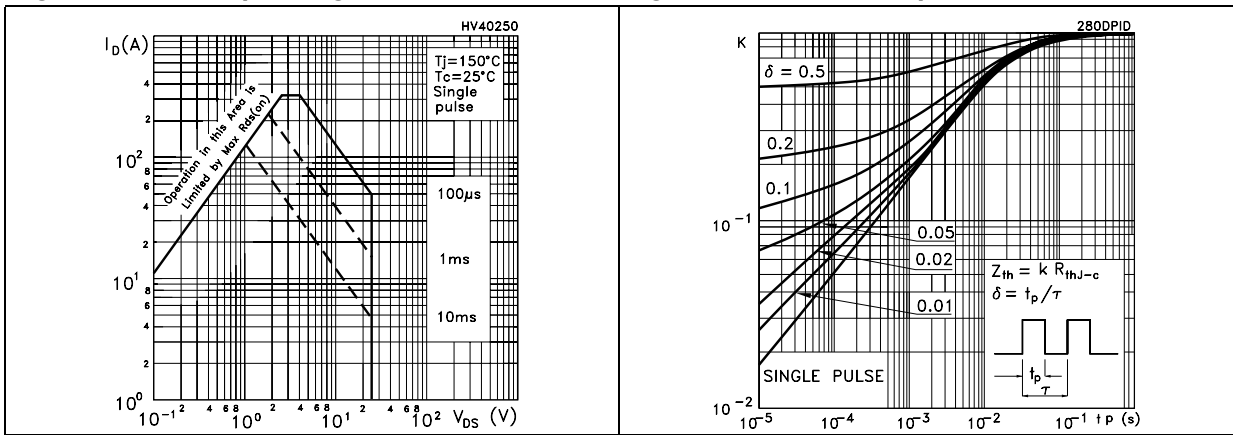

Figure 4. Safe operating area for TO-220 Figure 5. Thermal impedance for TO-220

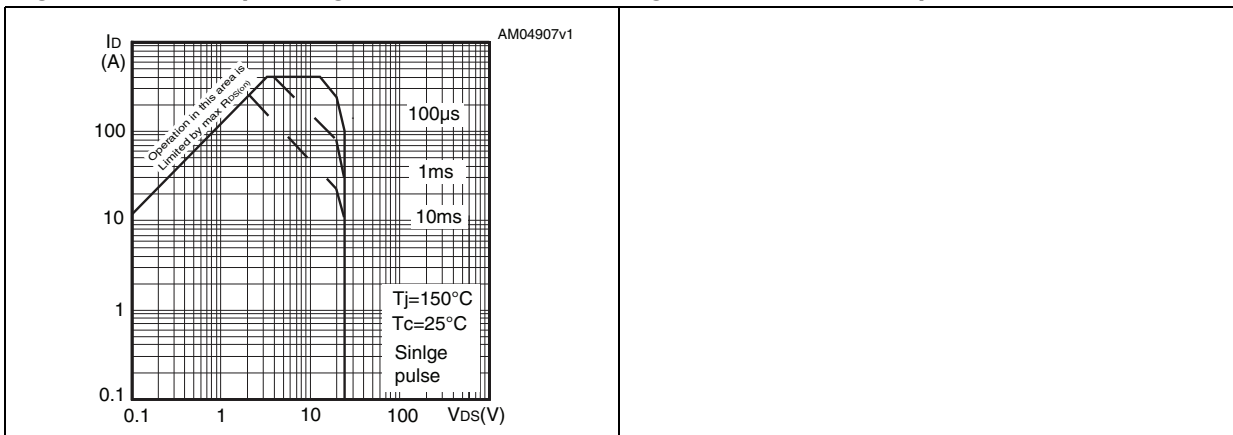

Figure 6. Output characteristics Figure 7. Transfer characteristics

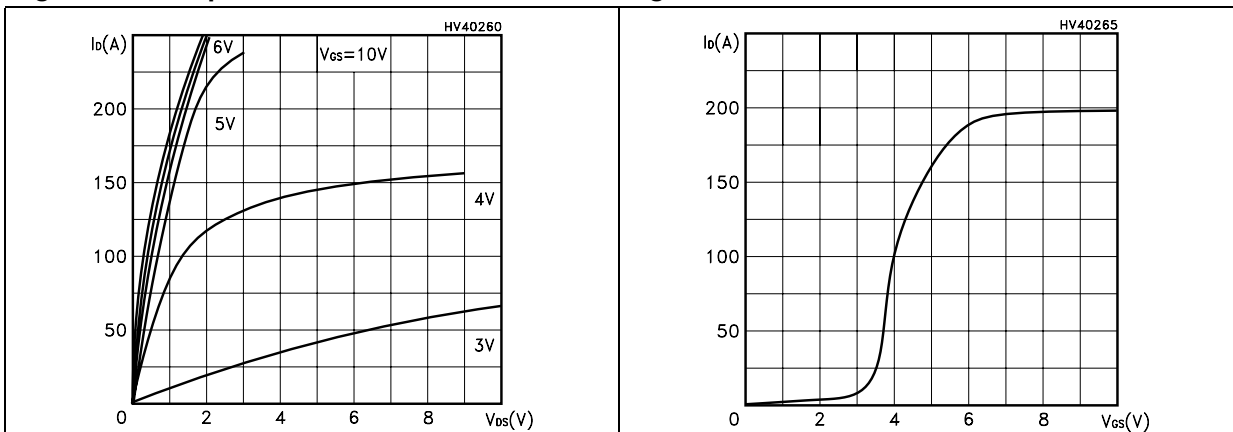

Figure 8. Normalized $B_{V_{DS}}$ vs temperature

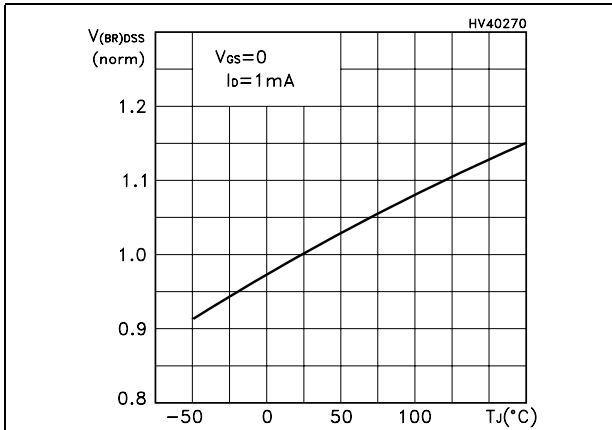

Figure 9. Static drain-source on resistance

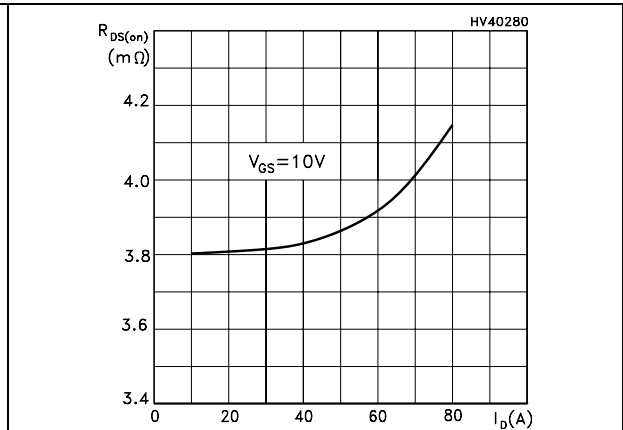

Figure 10. Gate charge vs gate-source voltage

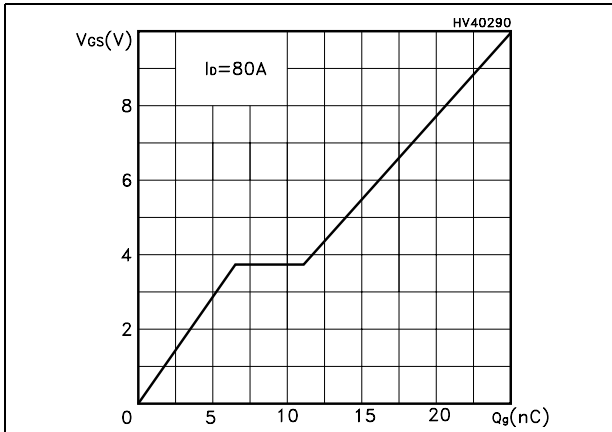

Figure 11. Capacitance variations

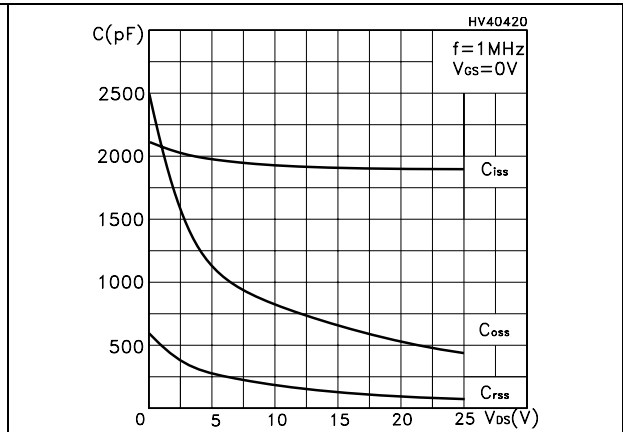

Figure 12. Normalized gate threshold voltage vs temperature

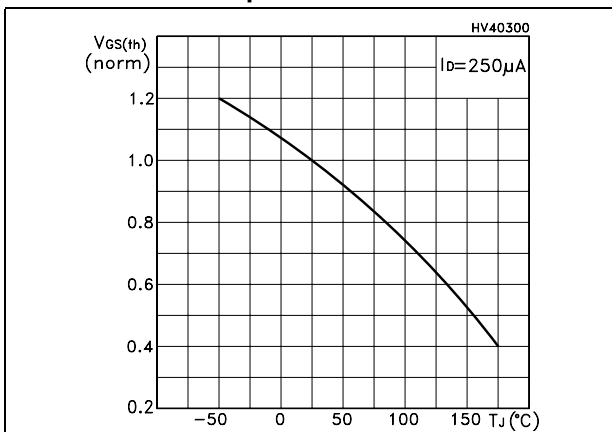

Figure 13. Normalized on resistance vs temperature

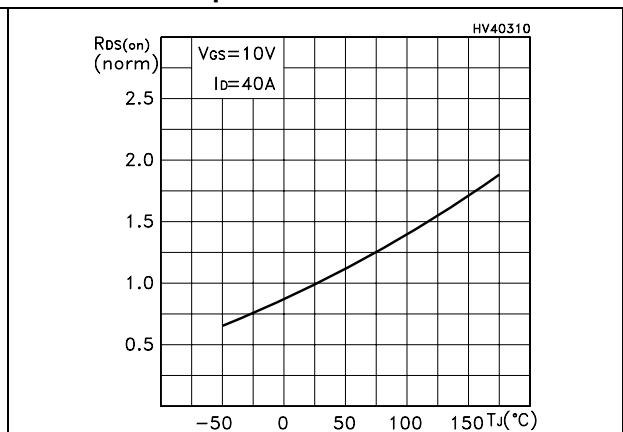
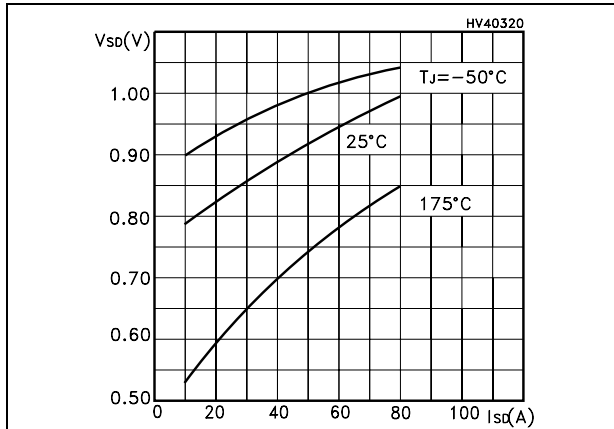

Figure 14. Source-drain diode forward characteristics



3 Test circuits

Figure 15. Unclamped inductive load test circuit

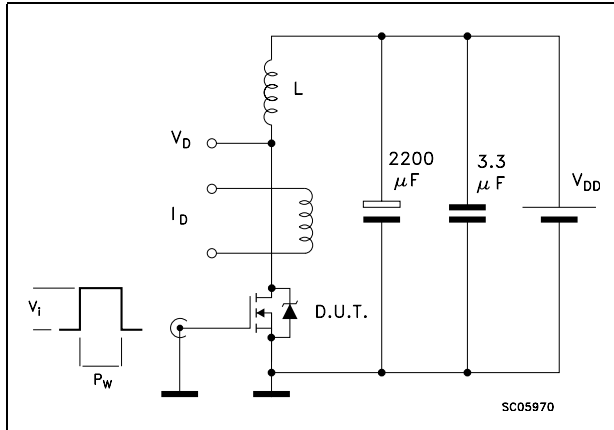

Figure 16. Unclamped inductive waveform

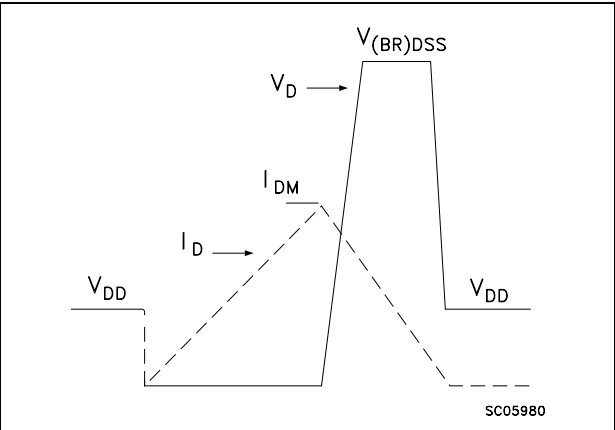

Figure 17. Switching times test circuit for resistive load

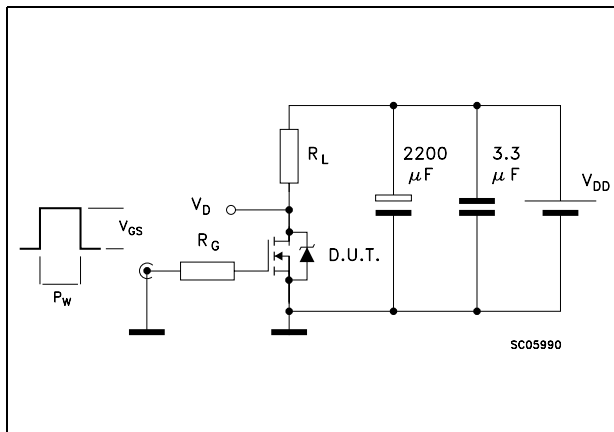

Figure 18. Gate charge test circuit

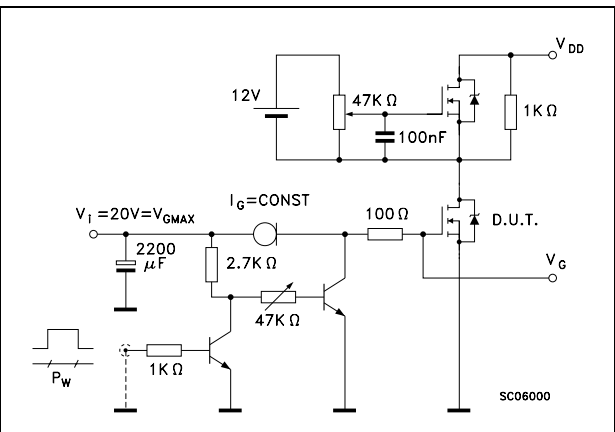

Figure 19. Test circuit for inductive load switching and diode recovery times

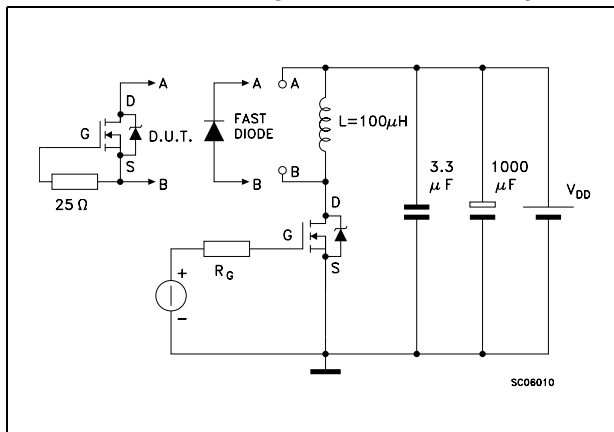

Figure 20. Switching time waveform

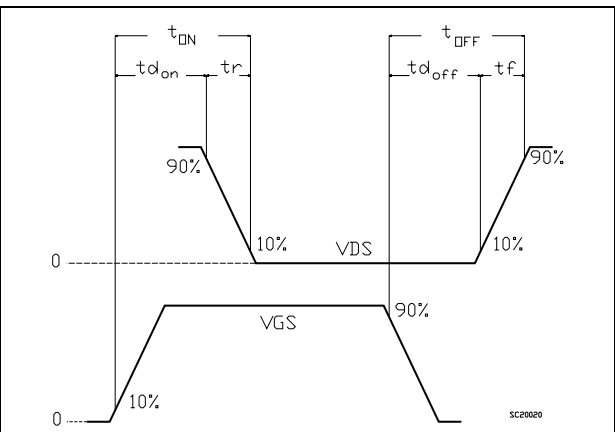
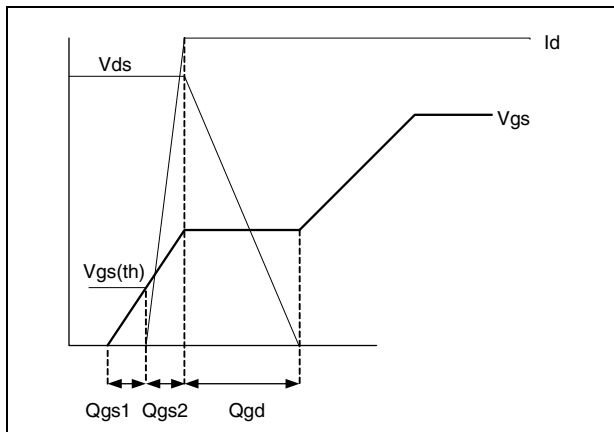

Figure 21. Gate charge waveform



4 Package mechanical data

In order to meet environmental requirements, ST offers these devices in different grades of ECOPACK[®] packages, depending on their level of environmental compliance. ECOPACK[®] specifications, grade definitions and product status are available at: www.st.com. ECOPACK is an ST trademark.

TO-220 type A mechanical data

Dim	mm		
	Min	Typ	Max
A	4.40		4.60
b	0.61		0.88
b1	1.14		1.70
c	0.48		0.70
D	15.25		15.75
D1		1.27	
E	10		10.40
e	2.40		2.70
e1	4.95		5.15
F	1.23		1.32
H1	6.20		6.60
J1	2.40		2.72
L	13		14
L1	3.50		3.93
L20		16.40	
L30		28.90	
∅P	3.75		3.85
Q	2.65		2.95

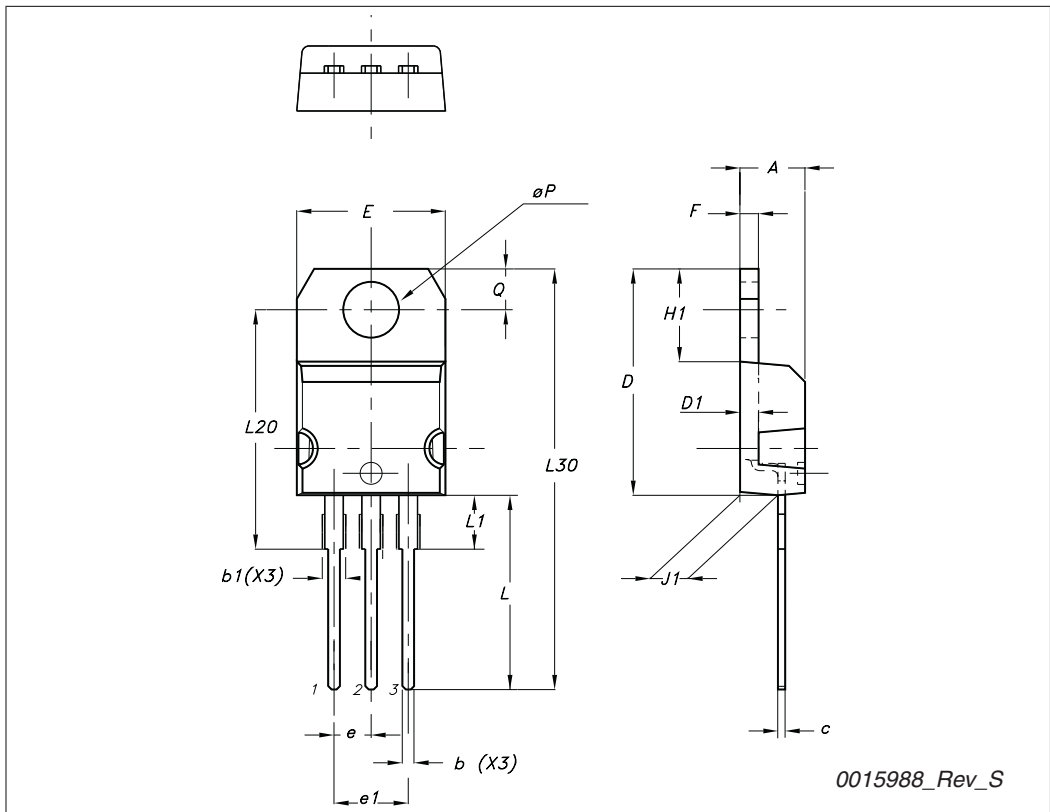

TO-251 (IPAK) mechanical data

DIM.	mm.		
	min.	typ	max.
A	2.20		2.40
A1	0.90		1.10
b	0.64		0.90
b2			0.95
b4	5.20		5.40
c	0.45		0.60
c2	0.48		0.60
D	6.00		6.20
E	6.40		6.60
e		2.28	
e1	4.40		4.60
H		16.10	
L	9.00		9.40
(L1)	0.80		1.20
L2		0.80	
V1		10 °	

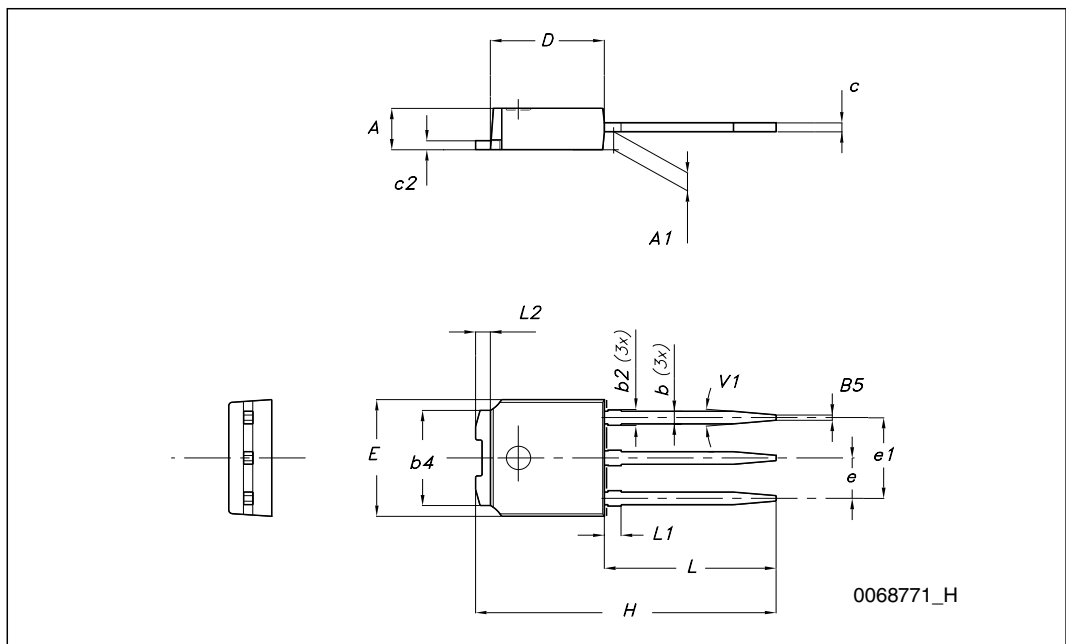

TO-252 (DPAK) mechanical data

DIM.	mm.		
	min.	typ	max.
A	2.20		2.40
A1	0.90		1.10
A2	0.03		0.23
b	0.64		0.90
b4	5.20		5.40
c	0.45		0.60
c2	0.48		0.60
D	6.00		6.20
D1		5.10	
E	6.40		6.60
E1		4.70	
e		2.28	
e1	4.40		4.60
H	9.35		10.10
L	1		
L1		2.80	
L2		0.80	
L4	0.60		1
R		0.20	
V2	0°		8°

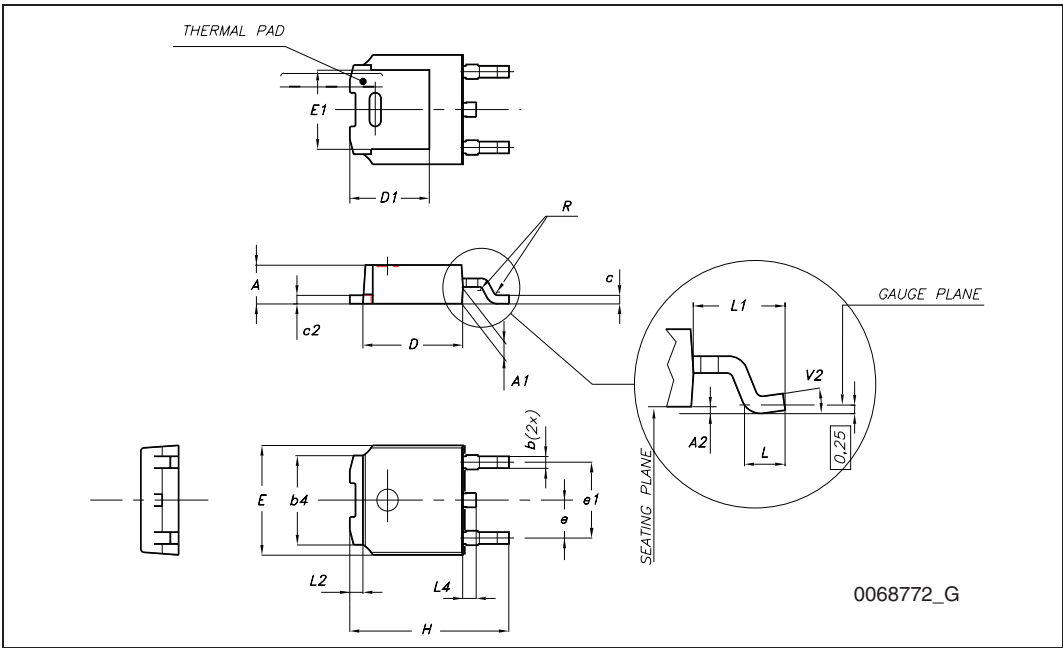

5 Packaging mechanical data

DPAK FOOTPRINT

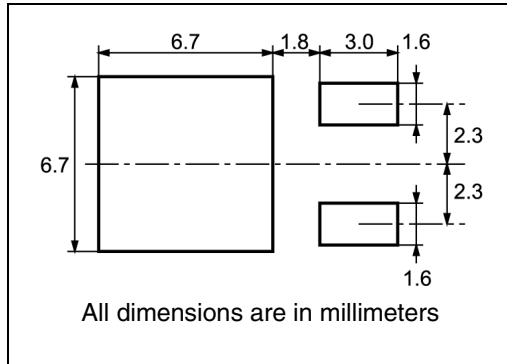

TAPE AND REEL SHIPMENT

40 mm min. Access hole at slot location

Full radius

2.5mm min. width

Tape slot in core for tape start

G measured at hub

REEL MECHANICAL DATA

DIM.	mm		inch	
	MIN.	MAX.	MIN.	MAX.
A		330		12.992
B	1.5		0.059	
C	12.8	13.2	0.504	0.520
D	20.2		0.795	
G	16.4	18.4	0.645	0.724
N	50		1.968	
T		22.4		0.881

BASE QTY	BULK QTY
2500	2500

TAPE MECHANICAL DATA

DIM.	mm		inch	
	MIN.	MAX.	MIN.	MAX.
A0	6.8	7	0.267	0.275
B0	10.4	10.6	0.409	0.417
B1		12.1		0.476
D	1.5	1.6	0.059	0.063
D1	1.5		0.059	
E	1.65	1.85	0.065	0.073
F	7.4	7.6	0.291	0.299
K0	2.55	2.75	0.100	0.108
P0	3.9	4.1	0.153	0.161
P1	7.9	8.1	0.311	0.319
P2	1.9	2.1	0.075	0.082
R	40		1.574	
W	15.7	16.3	0.618	0.641

For machine ref. only including draft and radii concentric around B0

10 pitches cumulative tolerance on tape +/- 0.2 mm

User Direction of Feed

FEED DIRECTION

Bending radius R min.

6 Revision history

Table 8. Document revision history

Date	Revision	Changes
16-Oct-2007	1	First release
20-Feb-2008	2	Modified Table 4.: Static
23-Sep-2008	3	V_{GS} value has been changed on Table 2 and Table 5
20-Apr-2009	4	Added device in TO-220
26-Apr-2010	5	<ul style="list-style-type: none">– Table 1: Device summary has been corrected– Section 4: Package mechanical data has been updated

Please Read Carefully:

Information in this document is provided solely in connection with ST products. STMicroelectronics NV and its subsidiaries ("ST") reserve the right to make changes, corrections, modifications or improvements, to this document, and the products and services described herein at any time, without notice.

All ST products are sold pursuant to ST's terms and conditions of sale.

Purchasers are solely responsible for the choice, selection and use of the ST products and services described herein, and ST assumes no liability whatsoever relating to the choice, selection or use of the ST products and services described herein.

No license, express or implied, by estoppel or otherwise, to any intellectual property rights is granted under this document. If any part of this document refers to any third party products or services it shall not be deemed a license grant by ST for the use of such third party products or services, or any intellectual property contained therein or considered as a warranty covering the use in any manner whatsoever of such third party products or services or any intellectual property contained therein.

UNLESS OTHERWISE SET FORTH IN ST'S TERMS AND CONDITIONS OF SALE ST DISCLAIMS ANY EXPRESS OR IMPLIED WARRANTY WITH RESPECT TO THE USE AND/OR SALE OF ST PRODUCTS INCLUDING WITHOUT LIMITATION IMPLIED WARRANTIES OF MERCHANTABILITY, FITNESS FOR A PARTICULAR PURPOSE (AND THEIR EQUIVALENTS UNDER THE LAWS OF ANY JURISDICTION), OR INFRINGEMENT OF ANY PATENT, COPYRIGHT OR OTHER INTELLECTUAL PROPERTY RIGHT.

UNLESS EXPRESSLY APPROVED IN WRITING BY AN AUTHORIZED ST REPRESENTATIVE, ST PRODUCTS ARE NOT RECOMMENDED, AUTHORIZED OR WARRANTED FOR USE IN MILITARY, AIR CRAFT, SPACE, LIFE SAVING, OR LIFE SUSTAINING APPLICATIONS, NOR IN PRODUCTS OR SYSTEMS WHERE FAILURE OR MALFUNCTION MAY RESULT IN PERSONAL INJURY, DEATH, OR SEVERE PROPERTY OR ENVIRONMENTAL DAMAGE. ST PRODUCTS WHICH ARE NOT SPECIFIED AS "AUTOMOTIVE GRADE" MAY ONLY BE USED IN AUTOMOTIVE APPLICATIONS AT USER'S OWN RISK.

Resale of ST products with provisions different from the statements and/or technical features set forth in this document shall immediately void any warranty granted by ST for the ST product or service described herein and shall not create or extend in any manner whatsoever, any liability of ST.

ST and the ST logo are trademarks or registered trademarks of ST in various countries.

Information in this document supersedes and replaces all information previously supplied.

The ST logo is a registered trademark of STMicroelectronics. All other names are the property of their respective owners.

© 2010 STMicroelectronics - All rights reserved

STMicroelectronics group of companies

Australia - Belgium - Brazil - Canada - China - Czech Republic - Finland - France - Germany - Hong Kong - India - Israel - Italy - Japan - Malaysia - Malta - Morocco - Philippines - Singapore - Spain - Sweden - Switzerland - United Kingdom - United States of America

www.st.com





Стандарт Электрон Связь

Мы молодая и активно развивающаяся компания в области поставок электронных компонентов. Мы поставляем электронные компоненты отечественного и импортного производства напрямую от производителей и с крупнейших складов мира.

Благодаря сотрудничеству с мировыми поставщиками мы осуществляем комплексные и плановые поставки широчайшего спектра электронных компонентов.

Собственная эффективная логистика и склад в обеспечивает надежную поставку продукции в точно указанные сроки по всей России.

Мы осуществляем техническую поддержку нашим клиентам и предпродажную проверку качества продукции. На все поставляемые продукты мы предоставляем гарантию .

Осуществляем поставки продукции под контролем ВП МО РФ на предприятия военно-промышленного комплекса России , а также работаем в рамках 275 ФЗ с открытием отдельных счетов в уполномоченном банке. Система менеджмента качества компании соответствует требованиям ГОСТ ISO 9001.

Минимальные сроки поставки, гибкие цены, неограниченный ассортимент и индивидуальный подход к клиентам являются основой для выстраивания долгосрочного и эффективного сотрудничества с предприятиями радиоэлектронной промышленности, предприятиями ВПК и научно-исследовательскими институтами России.

С нами вы становитесь еще успешнее!

Наши контакты:

Телефон: +7 812 627 14 35

Электронная почта: sales@st-electron.ru

Адрес: 198099, Санкт-Петербург,
Промышленная ул, дом № 19, литера Н,
помещение 100-Н Офис 331