

TFT Module Specification

MODEL: 13-057VMTB00A1-S

- < ◇ > PRELIMINARY SPECIFICATION
- < ◆ > APPROVAL SPECIFICATION

CUSTOMER
APPROVED BY
DATE:

DESIGNED	CHECKED	APPROVED
		 <p>PM 2014.08.22 呂家祥</p>

RECORD OF REVISION

Version	Revised Date	Page	Content
V1.0	2013/11/28	--	First Issued
V1.1	2014/08/22	16	Modify Brightness Min. 800 → 720 cd/m ²

TABLE OF CONTENTS

No.	Content	Page
	TFT Module Specification	1
	TABLE OF CONTENTS	3
1.	GENERAL DESCRIPTION	4
2.	MECHANICAL SPECIFICATION	5
3.	PIN DESCRIPTION	6
4.	ABSOLUTE MAXIMUM RATINGS	8
5.	BLOCK DIAGRAM	9
6.	RELATIONSHIP BETWEEN DISPLAYED COLOR AND INPUT	10
7.	ELECTRICAL CHARACTERISTICS	11
8.	OPTICAL CHARACTERISTICS	16
9.	RELIABILITY	19
10.	PRECAUTION RELATING PRODUCT HANDLING	24

1. GENERAL DESCRIPTION

1.1 Description

The specifications is model 13-057VMTB00A1-S is a color active matrix thin film transistor (TFT) liquid crystal display (LCD) that uses amorphous silicon TFT as a switching device. This model is composed of a TFT LCD panel, a driving circuit, a back light system. This TFT LCD has a 5.7 inch diagonally measured active display area with WVGA (640 horizontal by 480 vertical pixels) resolution.

1.2 Features:

No.	Item	Specification	Unit
1	Panel Size	5.7"	Inch
2	Number of Pixels	640 (W) x RGB x 480 (H)	Pixels
3	Active Area	115.2 (W) × 86.4 (H)	mm
4	Pixel Pitch	0.18 (W) x 0.18 (H)	mm
5	Outline Dimension	127 (W) × 98.43 (H) × 7 (T)	mm
6	Number of Colors	262K	- -
7	Display Mode	TN / Normally White / Transmissive	- -
8	View Direction	12 o'clock(Gray Inversion)	
9	Display Format	RGB vertical stripe	- -
10	Surface Treatment	Clear	- -
11	Contrast Ratio	300 (Typ.)	- -
12	Luminance (cd/m ²)	900 (Typ.)	cd/m ²
13	Interface	RGB 18bit Interface	- -
14	Backlight	White LED	- -
15	Operation Temperature	-20 ~ 70	°C
16	Storage Temperature	-30 ~ 80	°C
17	Weight	110	g

2. MECHANICAL SPECIFICATION

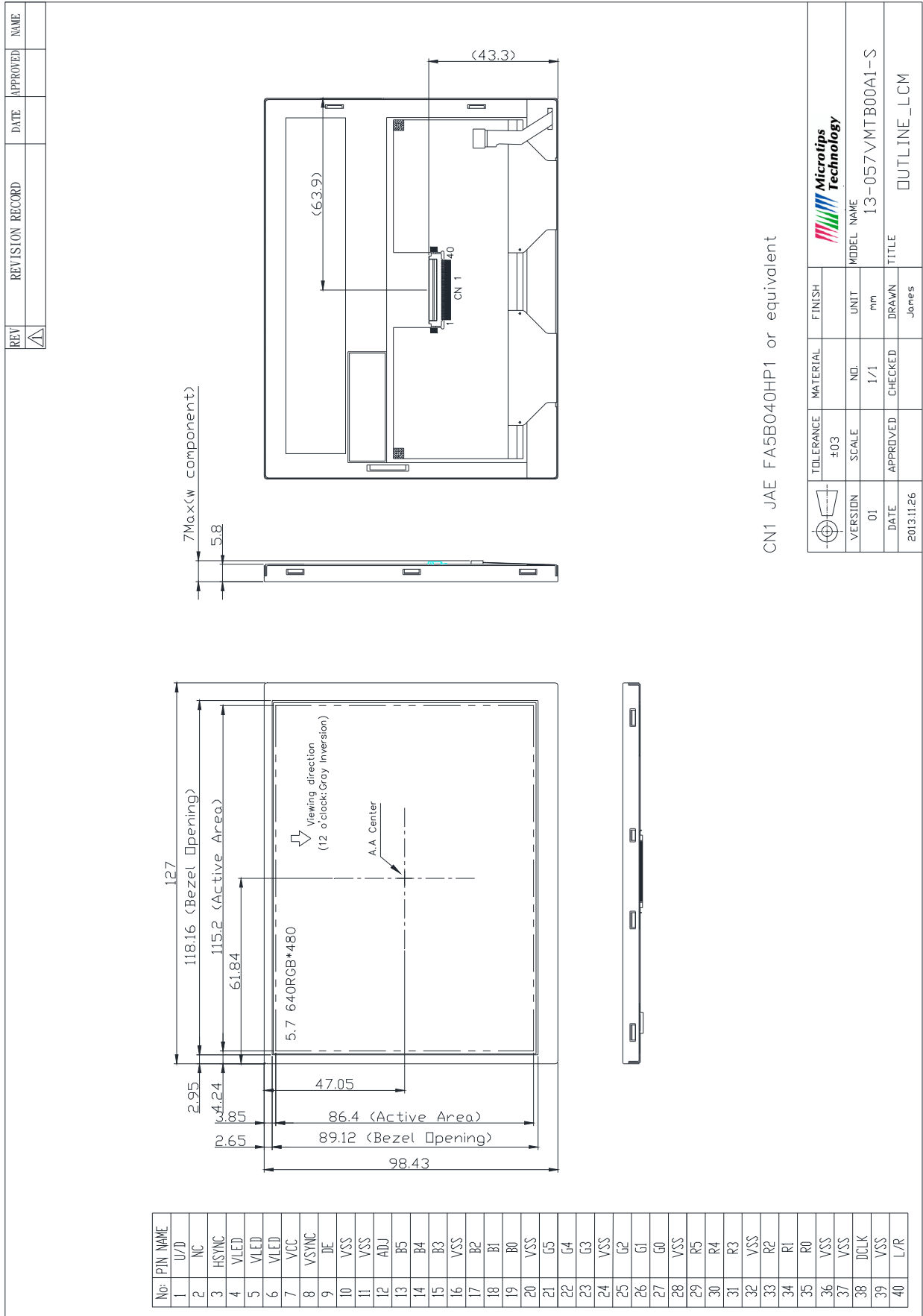

3. PIN DESCRIPTION

3.1 TFT LCD Module

Pin No.	Symbol	I/O	Function	Remark
1	U/D	I	Up or Down Display Control	
2	NC	-	No connection	
3	HSYNC	I	Horizontal SYNC Signal	
4	VLED	P	Power Supply for LED Driver	
5	VLED	P	Power Supply for LED Driver	
6	VLED	P	Power Supply for LED Driver	
7	VCC	P	Power Supply for system	
8	VSYNC	I	Vertical SYNC Signal	
9	DE	I	Data Enable Signal	
10	VSS	P	Ground	
11	VSS	P	Ground	
12	ADJ	I	Brightness control for LED B/L	
13	B5	I	Blue data signal (MSB)	
14	B4	I	Blue data signal	
15	B3	I	Blue data signal	
16	VSS	P	Ground	
17	B2	I	Blue data signal	
18	B1	I	Blue data signal	
19	B0	I	Blue data signal (LSB)	
20	VSS	P	Ground	
21	G5	I	Green data signal (MSB)	
22	G4	I	Green data signal	
23	G3	I	Green data signal	
24	VSS	P	Ground	
25	G2	I	Green data signal	
26	G1	I	Green data signal	
27	G0	I	Green data signal (LSB)	
28	VSS	P	Ground	
29	R5	I	Red data signal (MSB)	
30	R4	I	Red data signal	
31	R3	I	Red data signal	
32	VSS	P	Ground	
33	R2	I	Red data signal	

34	R1	I	Red data signal	
35	R0	I	Red data signal (LSB)	
36	VSS	P	Ground	
37	VSS	P	Ground	
38	DCLK	I	Clock Signals ; Latch Data at the Falling Edge	
39	VSS	P	Ground	
40	L/R	I	Left or Right Display Control	

Note:

- (1) VSS PIN must be grounding, cannot be floating.
- (2) U/D and L/R control Function

L/R	U/D	Function
1	0	Normally display
0	0	Left and Right opposite
1	1	Up and Down opposite
0	1	Left and Right opposite · Up and Down opposite

- (3) If DE signal is fixed low, SYNC mode is used. Otherwise, DE mode is used.

4. ABSOLUTE MAXIMUM RATINGS

4.1 Electrical Absolute Rating

4.1.1 TFT LCD Module

Item	Symbol	Values		Unit	Note
		Min	Max.		
Power supply voltage	VCC	-0.3	5.0	V	
	VLED	0	5.5	V	

4.1.2 Environment Absolute Rating

Item	Symbol	Values			Unit	Note
		Min	Typ	Max.		
Operating Temperature	Topa	-20		70	°C	Ambient temperature
Storage Temperature	Tstg	-30		80	°C	

5. BLOCK DIAGRAM

5.1 TFT LCD Module

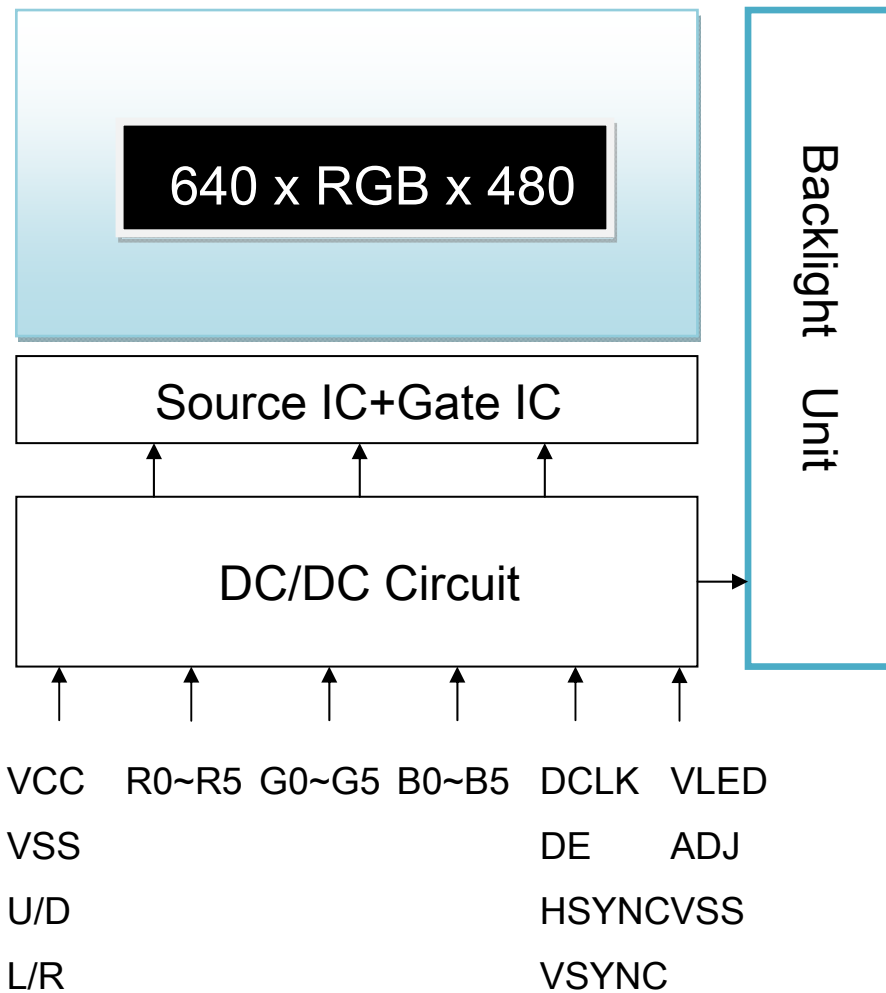

6. Relationship Between Displayed Color and Input

6.1 6 bit

	Color & Gray Scale	Data Signal																	
		R5	R4	R3	R2	R1	R0	G5	G4	G3	G2	G1	G0	B5	B4	B3	B2	B1	B0
Basic Color	Black	0	0	0	0	0	0	0	0	0	0	0	0	0	0	0	0	0	0
	Red	1	1	1	1	1	1	0	0	0	0	0	0	0	0	0	0	0	0
	Green	0	0	0	0	0	0	1	1	1	1	1	1	0	0	0	0	0	0
	Blue	0	0	0	0	0	0	0	0	0	0	0	0	1	1	1	1	1	1
	Cyan	0	0	0	0	0	0	1	1	1	1	1	1	1	1	1	1	1	1
	Magenta	1	1	1	1	1	1	0	0	0	0	0	0	1	1	1	1	1	1
	Yellow	1	1	1	1	1	1	1	1	1	1	1	1	0	0	0	0	0	0
	White	1	1	1	1	1	1	1	1	1	1	1	1	1	1	1	1	1	1
Red	Black	0	0	0	0	0	0	0	0	0	0	0	0	0	0	0	0	0	0
	Red(1)	0	0	0	0	0	1	0	0	0	0	0	0	0	0	0	0	0	0
	Red(2)	0	0	0	0	1	0	0	0	0	0	0	0	0	0	0	0	0	0
	:	:	:	:	:	:	:	:	:	:	:	:	:	:	:	:	:	:	:
	Red(31)	0	1	1	1	1	1	0	0	0	0	0	0	0	0	0	0	0	0
	:	:	:	:	:	:	:	:	:	:	:	:	:	:	:	:	:	:	:
Green	Black	0	0	0	0	0	0	0	0	0	0	0	0	0	0	0	0	0	0
	Green(1)	0	0	0	0	0	0	0	0	0	0	0	1	0	0	0	0	0	0
	Green(2)	0	0	0	0	0	0	0	0	0	0	1	0	0	0	0	0	0	0
	:	:	:	:	:	:	:	:	:	:	:	:	:	:	:	:	:	:	:
	Green(31)	0	0	0	0	0	0	0	1	1	1	1	0	0	0	0	0	0	0
	:	:	:	:	:	:	:	:	:	:	:	:	:	:	:	:	:	:	:
Blue	Black	0	0	0	0	0	0	0	0	0	0	0	0	0	0	0	0	0	0
	Blue(1)	0	0	0	0	0	0	0	0	0	0	0	0	0	0	0	0	0	1
	Blue(2)	0	0	0	0	0	0	0	0	0	0	0	0	0	0	0	0	1	0
	:	:	:	:	:	:	:	:	:	:	:	:	:	:	:	:	:	:	:
	Blue(31)	0	0	0	0	0	0	0	0	0	0	0	0	0	1	1	1	1	1
	:	:	:	:	:	:	:	:	:	:	:	:	:	:	:	:	:	:	:
Blue	Blue(62)	0	0	0	0	0	0	0	0	0	0	0	0	1	1	1	1	1	0
	Blue(63)	0	0	0	0	0	0	0	0	0	0	0	0	1	1	1	1	1	1

0 : Low level voltage, 1 :High level voltage

Each basic color can be displayed in 64 gray scales from 6 bit data signals. With the combination of total 18 bit data signals, the 262K-color display can be achieved on the screen.

7. ELECTRICAL CHARACTERISTICS

7.1 TFT LCD Module

Item	Symbol	Value			Unit	Note	
		Min.	Typ.	Max.			
Power supply voltage	VCC	3.0	3.3	3.6	V		
	VLED	4.5	5	5.5	V		
Input Voltage for logic	H Level	VIH	0.7xVCC	-	VCC	V	
	L Level	VIL	0	-	0.3xVCC	V	
PWM frequency	ADJ	19K	20K	21K	Hz	Note2	
Digital Current	ICC	-	111	140	mA	Note1	
	ILED	-	333	400	mA	VLED=5V	
LED Life Time (25°C)	-	(50000)	-	-	hr	Note3	

Note 1: frame =60Hz , Ta=25°C , Display pattern : Black pattern

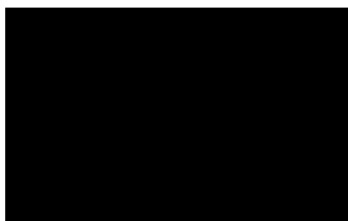

Note 2: ADJ signal is 0~3.3V.Operation frequency is 20KHz

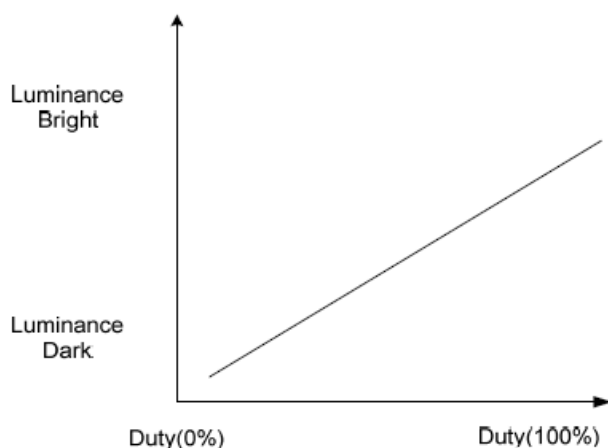

Note 3: The “LED life time” is defined as the module brightness decrease to 50% original brightness that the ambient temperature is 25°C 60% RH.

7.2 INTERFACE SPECIFICATIONS

7.2.1 DE Mode Input Timing Table

Signal	Parameter	Symbol	Min.	Typ.	Max.	Unit.	Note
DCLK	CLK frequency	fCLK	23	25	30	MHz	
	CLK period	tCLK	33	40	43	ns	
	CLK pulse duty	-	45	50	55	%	
	Low Level Width	tWCL	6	-	-	ns	
	High Level Width	tWCH	6	-	-	ns	
	Rise, Fall Time	tCLKr,tCLKf	-	-	3	ns	
DE	Setup Time	tDES	5	-	-	ns	
	Hold Time	tDEH	10	-	-	ns	
	Rise, Fall Time	tDEr,tDEf	-	-	16	ns	
	Horizontal Line	tHP	750	800	900	tCLK	
	HS Display Area	tHV	640	640	640	tCLK	
	HS Blank	tHBK	110	160	260	tCLK	
	VS Display Area	tVP	515	525	560	tHP	
	VS Period Time	tVV	480	480	480	tHP	
	VS Blank	tVBK	35	45	80	tHP	
VS Frequency	fV	55	60	65	Hz		
Data R,G,B	Setup Time	tDS	5	-	-	ns	
	Hold Time	tDH	10	-	-	ns	
	Rise, Fall Time	tDr,tDf	-	-	3	ns	

Note: (1) tCLKL / tCLK.

7.2.2 DE mode timing waveform

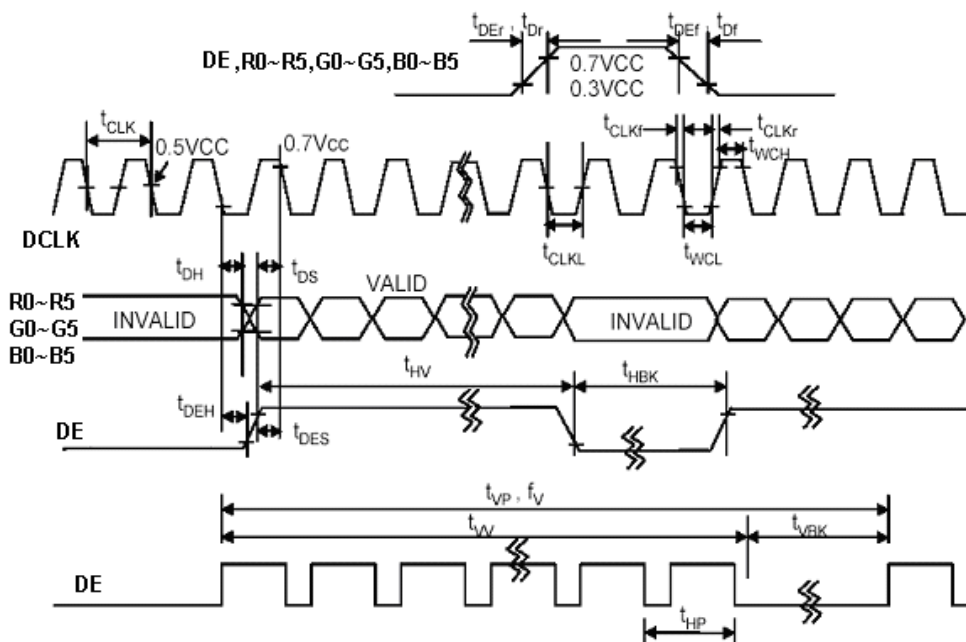

7.2.3 SYNC mode Input signal characteristics

Signal	Parameter	Symbol	Min.	Typ.	Max.	Unit.	Note
DCLK	CLK frequency	fCLK	23	25	30	MHz	
	CLK period	tCLK	33	40	43	ns	
	Low Level Width	tWCL	6	-	-	ns	
	High Level Width	tWCH	6	-	-	ns	
	Rise, Fall Time	tCLKr, tCLKf	-	-	3	ns	
HSYNC	Horizontal Line	tHP	750	800	900	tCLK	
	HS Display Area	tHV	640	640	640	tCLK	
	HS Pulse Width	tHW	5	30	-	tCLK	
	HS Back Porch	tHBP	1	114	139	tCLK	
	HS Front Porch	tHFP	1	16	116	tCLK	
	HS Blanking	tHBK	1	160	260	tCLK	
	HS Width+ Back Porch	tHW+tHBP	144	144	144	tCLK	
VSYNC	VS Period Time	tVP	515	525	560	tHP	
	VS Display Area	tVV	480	480	480	tHP	
	VS Pulse Width	tVW	1	3	5	tHP	
	VS Back Porch	tVBP	30	32	34	tHP	
	VS Front Porch	tVFP	1	10	45	tHP	
	VS Width+ Back Porch	tVW+tVBP	35	35	35	tHP	
	VS Blanking	tVBK	35	45	80	tHP	
DATA	Setup Time	tDS	5	-	-	ns	
	Hold Time	tDH	10	-	-	ns	

Note: (1) tHBK = tHFP + tHW + tHBP.

7.2.4 SYNC mode timing waveform

Input vertical timing:

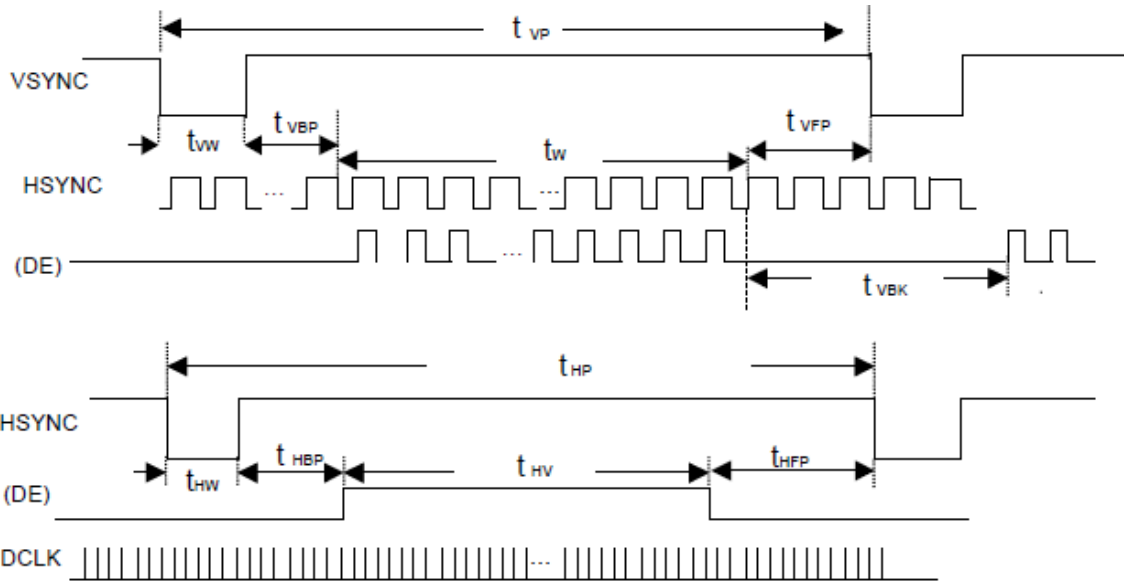

Note: If SYNC mode is used, please fix DE signal to low, DE timing waveform is for reference only.

Input horizontal timing:

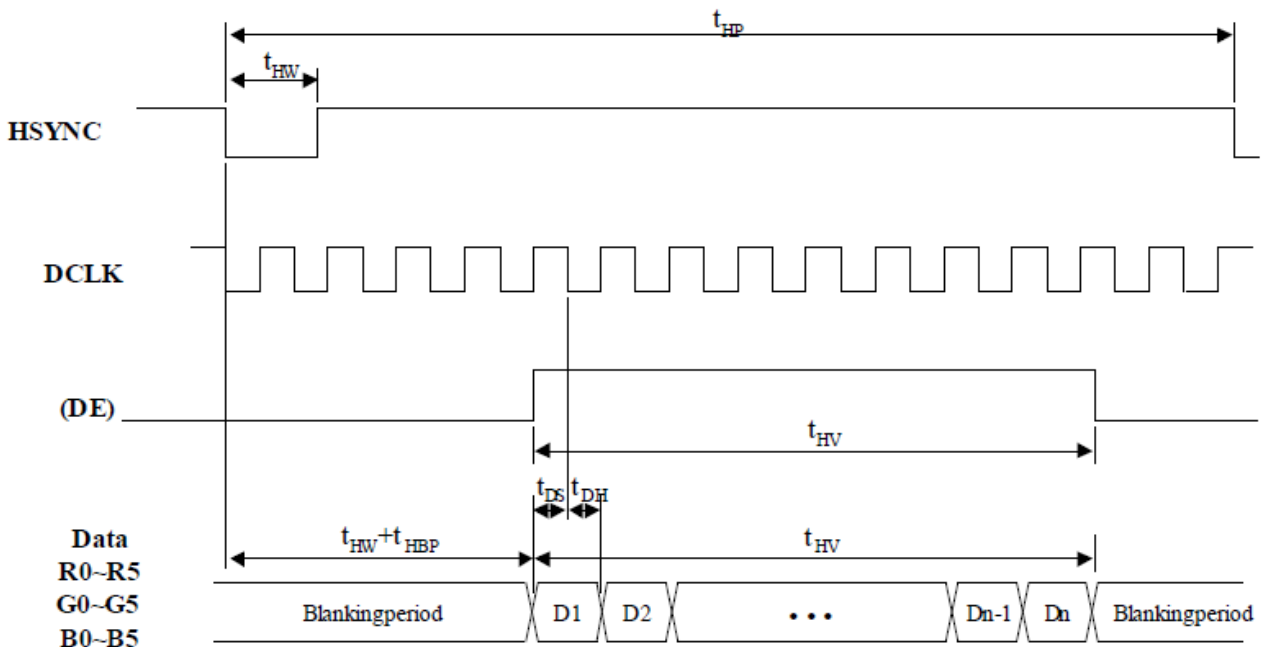

Note: If SYNC mode is used, please fix DE signal to low, DE timing waveform is for reference only

7.3 Power On / Off Sequence

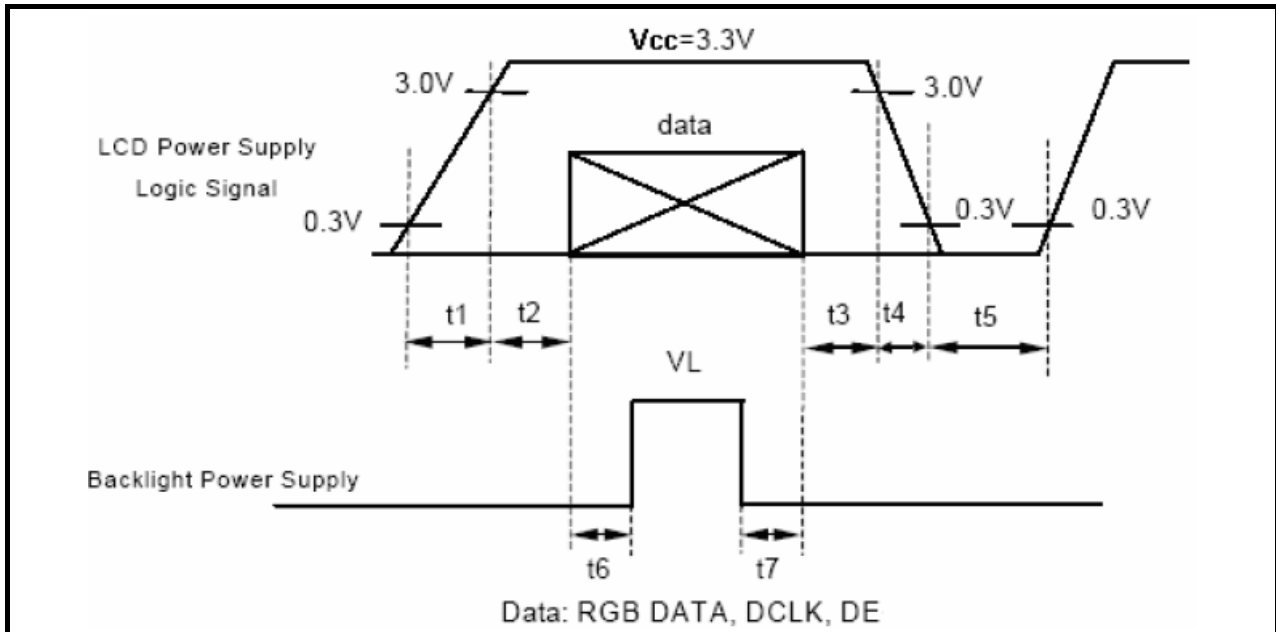

$t_1 \leq 10\text{ms} : 1 \text{ sec} \leq t_5$
 $50\text{ms} \leq t_2 : 200\text{ms} \leq t_6$
 $0 < t_3 \leq 50\text{ms} : 200\text{ms} \leq t_7$
 $0 < t_4 \leq 10\text{ms}$

8. OPTICAL CHARACTERISTICS

Item	Symbol	Condition	Min.	Typ.	Max.	Unit
Brightness	--	Note1, Note 3, ($\theta = 0^\circ$; Normal Viewing Angle)	720	900	--	cd/m ²
Uniformity	B-uni		70	80	-	%
Contrast Ratio	CR		200	300	--	--
Response Time	Tr		--	15	--	ms
	Tf		--	35	--	ms
Color Chromaticity	White	Wx	0.259	0.309	0.359	--
		Wy	0.270	0.320	0.370	--
View angle	Horizontal	$\theta x+$	60	70	--	
		$\theta x-$	60	70	--	
	Vertical	$\theta Y+$	50	60	--	
		$\theta Y-$	30	40	--	
Image sticking	tis	2 hours	--	--	2	Sec

Note : The following optical specifications shall be measured in a darkroom or equivalent state (ambient luminance ≤ 1 lux, and at room temperature). The operation temperature is $25^\circ\text{C} \pm 2^\circ\text{C}$. The measurement method is shown in Note1.

Note1: The method of optical measurement:

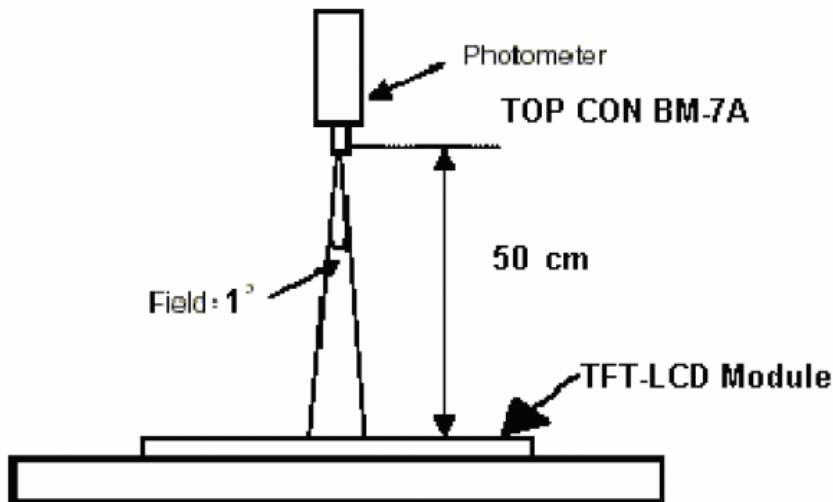

Note2: Measured at the center area of the panel and at the viewing angle of the $\theta x = \theta y = 0^\circ$

Note3: Definition of Contrast Ratio (CR):

CR = Luminance with all pixels in white state \div Luminance with all pixels in Black state

Note4: Definition of Viewing Angle:

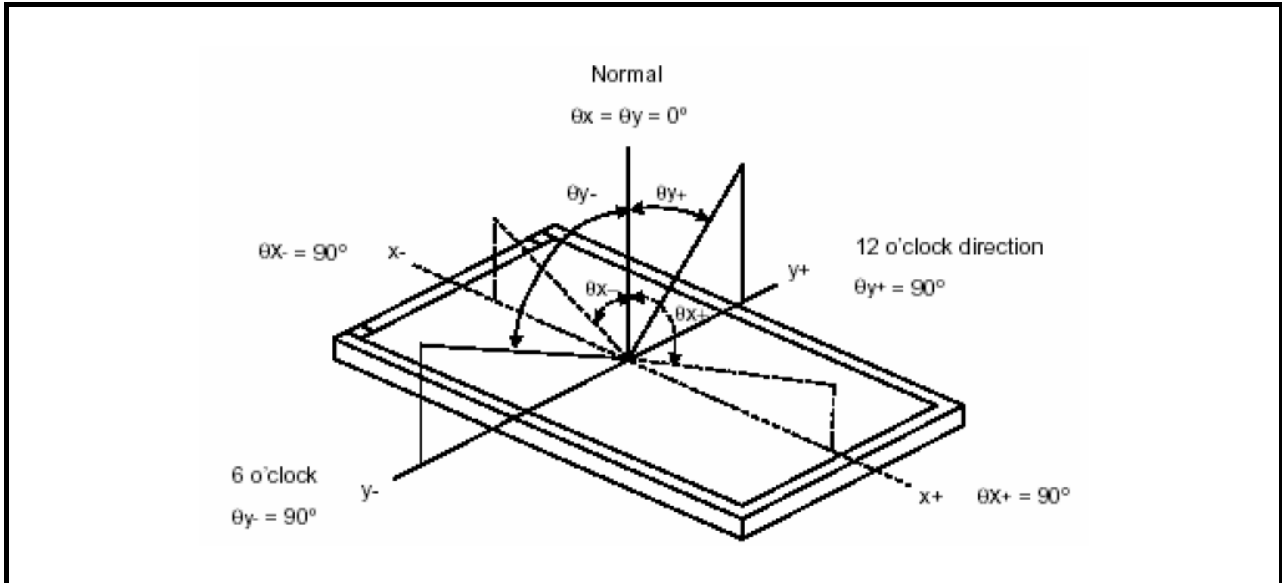

Note 5: Definition of Brightness Uniformity (B-uni):

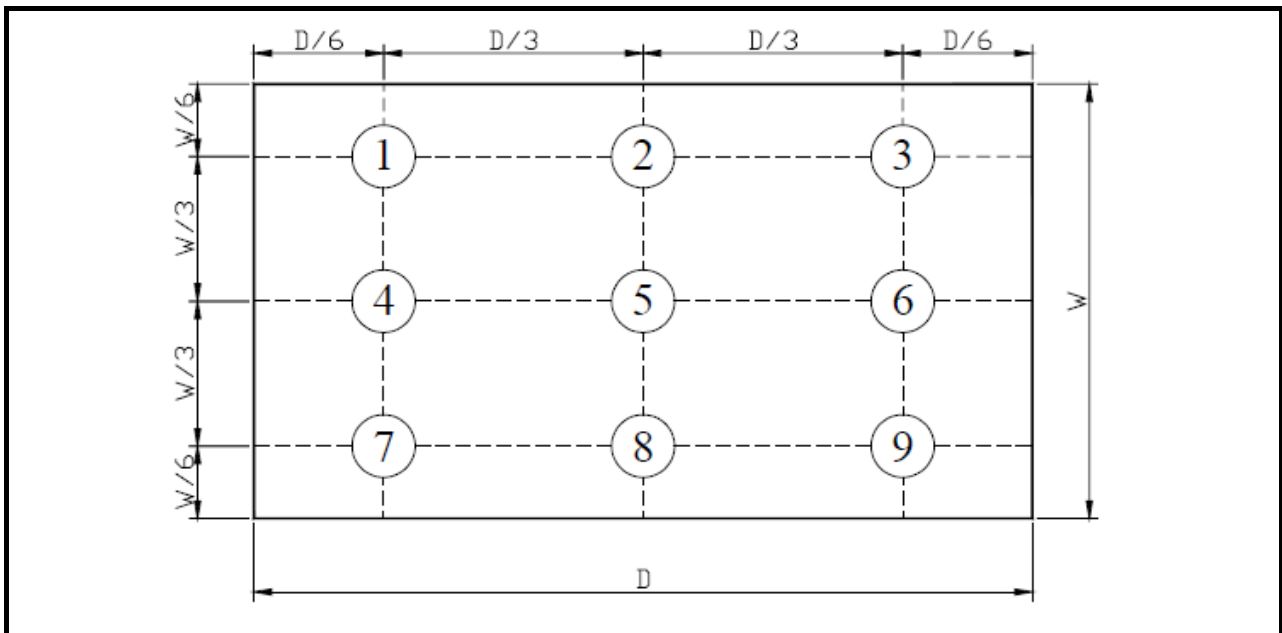

B-uni = (Minimum luminance of 9 points ÷ Maximum luminance of 9 points) X 100%

Note 6: Definition of Response Time:

The Response Time is set initially by defining the “Rising Time (T_r)” and the “Falling Time (T_f)” respectively. T_r and T_f are defined as following figure

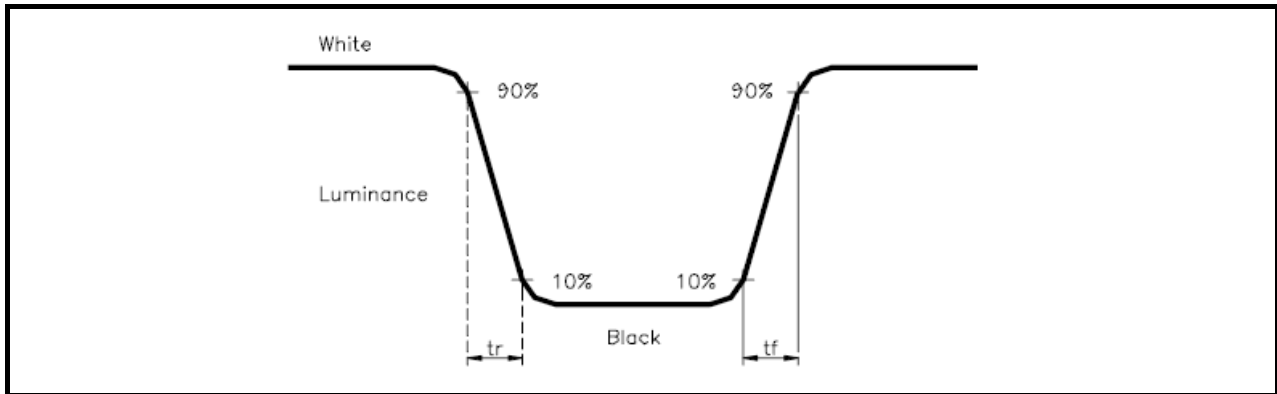

Note 7: Definition of Chromaticity:

The color coordinates (W_x, W_y), (R_x, R_y), (G_x, G_y), and (B_x, B_y) are obtained with all pixels in the viewing field at white, red, green, and blue states, respectively.

Note 8: Definition of Image sticking (t_{is}):

Continuously display the test pattern shown in the figure below for 2 hours. Then display a completely white screen. The previous image shall not persist more than 2 sec at 25 °C

Image sticking pattern

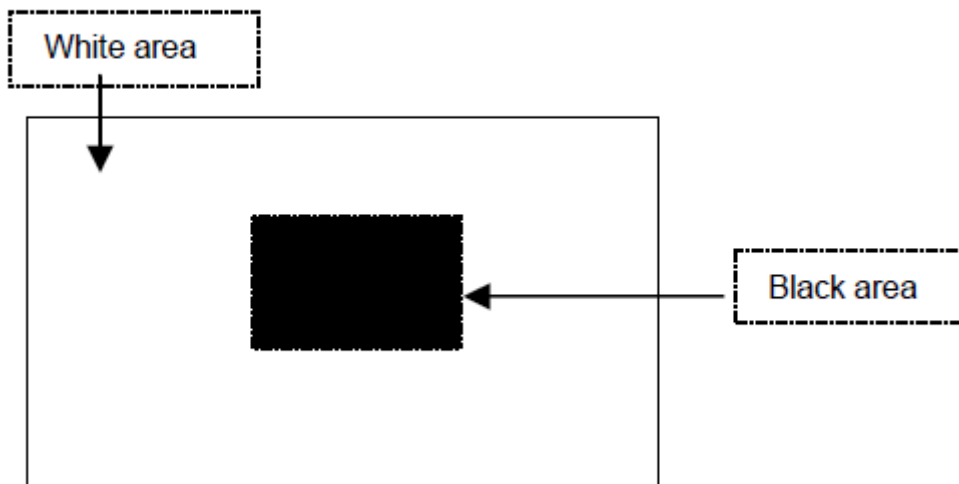

9. RELIABILITY

9.1 Test Condition

9.1.1 Temperature and Humidity(Ambient Temperature)

Temperature : $25 \pm 5^{\circ}\text{C}$

Humidity : $65 \pm 5\%$

9.1.2 Operation

Unless specified otherwise, test will be conducted under function state.

9.1.3 Container

Unless specified otherwise, vibration test will be conducted to the product itself without putting it in a container.

9.1.4 Test Frequency

In case of related to deterioration such as shock test. It will be conducted only once.

9.2 TESTS

No.	ITEM	CONDITION CRITERION
1	High Temperature Storage	80°C, 240 hrs
2	Low Temperature Storage	-30°C, 240 hrs
3	High Temperature Operating	70°C, 240 hrs
4	Low Temperature Operating	-20°C, 240 hrs
5	High Temperature/Humidity Non-Operating	60°C, 90%RH, 240 hrs
6	Temperature Shock Non-Operating	-30°C ←+25°C → 80°C (0.5hr each), 200 cycles
7	Vibration Test Non-Operating	Frequency:0 ~ 55 Hz Amplitude:1.5 mm Sweep Time:11min Test Period:6 Cycles for each Direction of X,Y,Z
8	Electro-static Discharge Non-Operating	150pF,330Ω Air:± 12KV;Contact: ±6KV 10 times/point;4 points/panel face

Note1: The test sample have recovery time for 24 hours at room temperature before the function check. In the standard conditions, there is no any touch panel function NG issue occurred.

9.3 JUDGMENT STANDARD

The judgment of the above test should be made as follow:

Pass: Normal display image with no obvious non-uniformity and no line defect. Partial transformation of the module parts should be ignored.

Fail: No display image, obvious non-uniformity, or line defects.

9.4 INCOMING INSPECTION STANDARDS

No.	Parameter	Criteria														
1	Operating	Display function: No Display malfunction (Major)														
		Contrast ratio (Black, White): Does not meet specified range in the spec. (Major) (Note:3)														
		Line Defect: No obvious Vertical and Horizontal line defect in bright, dark and colored. (Major) (Note:1)														
		Point Defect : Active area ≤ 5 dots (Minor) (Note:1)														
		<table border="1"> <thead> <tr> <th rowspan="2">Item</th> <th>Acceptable number</th> <th rowspan="2">Total</th> </tr> <tr> <th>Active Area</th> </tr> </thead> <tbody> <tr> <td>Bright</td> <td>2</td> <td rowspan="2">5</td> </tr> <tr> <td>Dark</td> <td>4</td> </tr> </tbody> </table>	Item	Acceptable number	Total	Active Area	Bright	2	5	Dark	4					
Item	Acceptable number	Total														
	Active Area															
Bright	2	5														
Dark	4															
2	External Inspection (non-operating)	Non-uniformity: Visible through 5%ND filter. (Minor)														
		Foreign material in Black or White spots shape ($W > 1/4L$)														
		<table border="1"> <thead> <tr> <th>Zone Dimension</th> <th>Acceptable number</th> <th rowspan="3">Class Of Defects</th> <th rowspan="3">AQL Level</th> </tr> </thead> <tbody> <tr> <td>$D > 0.5$</td> <td>0</td> </tr> <tr> <td>$0.3 < D \leq 0.5$</td> <td>5</td> </tr> <tr> <td>$D \leq 0.3$</td> <td>*</td> <td>Minor</td> <td>1.5</td> </tr> </tbody> </table> <p>$D = (\text{Long} + \text{Short}) / 2$ * : Disregard</p>	Zone Dimension	Acceptable number	Class Of Defects	AQL Level	$D > 0.5$	0	$0.3 < D \leq 0.5$	5	$D \leq 0.3$	*	Minor	1.5		
		Zone Dimension	Acceptable number	Class Of Defects			AQL Level									
		$D > 0.5$	0													
$0.3 < D \leq 0.5$	5															
$D \leq 0.3$	*	Minor	1.5													
Foreign Material in Line or spiral shape ($W \leq 1/4L$) (Note: 4)																
<table border="1"> <thead> <tr> <th>L (mm)</th> <th>Zone W(mm)</th> <th>Acceptable number</th> <th rowspan="3">Class Of Defects</th> <th rowspan="3">AQL Level</th> </tr> </thead> <tbody> <tr> <td>$L > 5$</td> <td>$W > 0.1$</td> <td>0</td> </tr> <tr> <td>$0.5 < L \leq 5$</td> <td>$0.03 < W \leq 0.1$</td> <td>5</td> </tr> <tr> <td>$L \leq 0.5$</td> <td>$W \leq 0.03$</td> <td>*</td> <td>Minor</td> <td>1.5</td> </tr> </tbody> </table> <p>L : Length W : Width * : Disregard</p>	L (mm)	Zone W(mm)	Acceptable number	Class Of Defects	AQL Level	$L > 5$	$W > 0.1$	0	$0.5 < L \leq 5$	$0.03 < W \leq 0.1$	5	$L \leq 0.5$	$W \leq 0.03$	*	Minor	1.5
L (mm)	Zone W(mm)	Acceptable number	Class Of Defects			AQL Level										
$L > 5$	$W > 0.1$	0														
$0.5 < L \leq 5$	$0.03 < W \leq 0.1$	5														
$L \leq 0.5$	$W \leq 0.03$	*	Minor	1.5												
2	External Inspection (non-operating)	Dimension: Outline (Major)														
		Bezel appearance: uneven (Minor)														
		Scratch on the polarize: (Note:2)														
		<table border="1"> <thead> <tr> <th>L (mm)</th> <th>Zone W(mm)</th> <th>Acceptable number</th> <th rowspan="2">Class Of Defects</th> <th rowspan="2">AQL Level</th> </tr> </thead> <tbody> <tr> <td>--</td> <td>$W > 0.1$</td> <td>0</td> </tr> <tr> <td>$L \leq 3$</td> <td>$W \leq 0.1$</td> <td>3</td> <td>Minor</td> <td>1.5</td> </tr> </tbody> </table> <p>L : Length W : Width * : Disregard</p>	L (mm)	Zone W(mm)	Acceptable number	Class Of Defects	AQL Level	--	$W > 0.1$	0	$L \leq 3$	$W \leq 0.1$	3	Minor	1.5	
		L (mm)	Zone W(mm)	Acceptable number	Class Of Defects			AQL Level								
--	$W > 0.1$	0														
$L \leq 3$	$W \leq 0.1$	3	Minor	1.5												
Dent or bubble on the polarize (Note:2)																
<table border="1"> <thead> <tr> <th>Zone Dimension</th> <th>Acceptable number</th> <th rowspan="2">Class Of Defects</th> <th rowspan="2">AQL Level</th> </tr> </thead> <tbody> <tr> <td>$D \leq 0.3$</td> <td>*</td> </tr> <tr> <td>$D \leq 0.5$</td> <td>3</td> <td>Minor</td> <td>1.5</td> </tr> </tbody> </table> <p>$D = (\text{Long} + \text{Short}) / 2$ * : Disregard</p>	Zone Dimension	Acceptable number	Class Of Defects	AQL Level	$D \leq 0.3$	*	$D \leq 0.5$	3	Minor	1.5						
Zone Dimension	Acceptable number	Class Of Defects			AQL Level											
$D \leq 0.3$	*															
$D \leq 0.5$	3	Minor	1.5													

Class of defects			Definition
	Major	AQL 0.65%	It is a defect that is likely to result in failure or to reduce materially the usability of the product for the intended function.
Minor	AQL 1.5%	It is a defect that will not result in functioning problem with deviation classified.	

Note1:

(a) Bright point defect is defined as point defect of R,G,B with area $>1/2$ pixel respectively

(b) Dark point defect is defined as visible in full white pattern.

(c) Definition of distribution of point defect is as follows:

- minimum separation between dark point defects should be larger than 5mm.
- minimum separation between bright point defects should be larger than 5mm.

(d) Definition of joined bright point defect and joined dark point defect are as follows:

- Two or more joined bright point defects must be nil.
- Three joined dark point defects must be nil.
- Coupling of one dark and one bright point in junction is counted as one dark and bright spot with 1 pair maximum.
- Two Joined dark point is counted as two dark points with 2 pair maximum.

Note2: The external inspection should be conducted at the distance 30 ± 5 cm between the eyes of inspector and the panel.

Note3: Luminance measurement for contrast ratio is at the distance 50 ± 5 cm between the detective head and the panel with ambient luminance less than 1 lux. Contrast ratio is obtained at optimum view angle.

Note4: W-Width in mm , L-length of Max.(L1,L2) in mm.

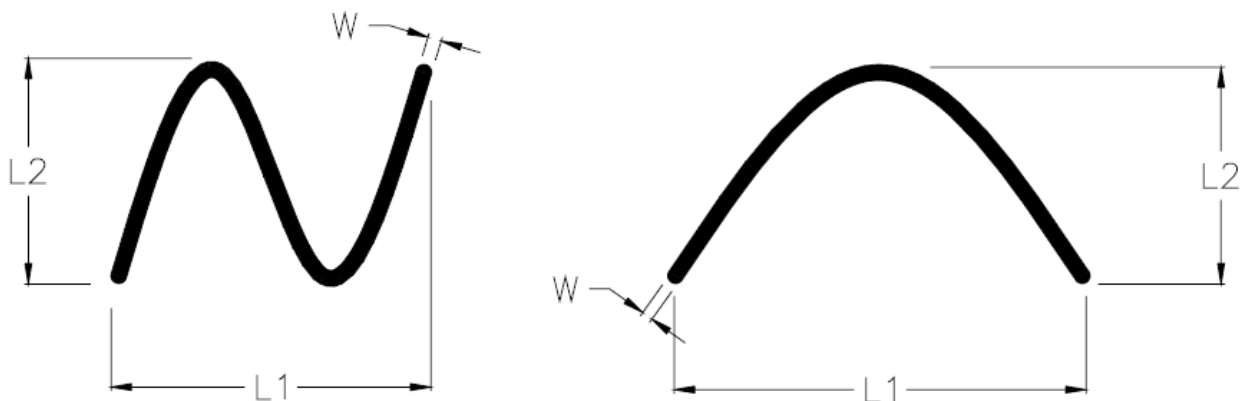

9.5 Sampling Condition

Unless otherwise agree in written, the sampling inspection shall be applied to the incoming inspection of customer.

Lot size: Quantity of shipment lot per model.

Sampling type: normal inspection, single sampling

Sampling table: MIL-STD-105E

Inspection level: Level II

9.6 Inspection conditions

The LCD shall be inspected under 40W white fluorescent light.

$\theta \leq 45^\circ$ inspection under non-operating condition.

$\theta \leq 5^\circ$ inspection under operating condition

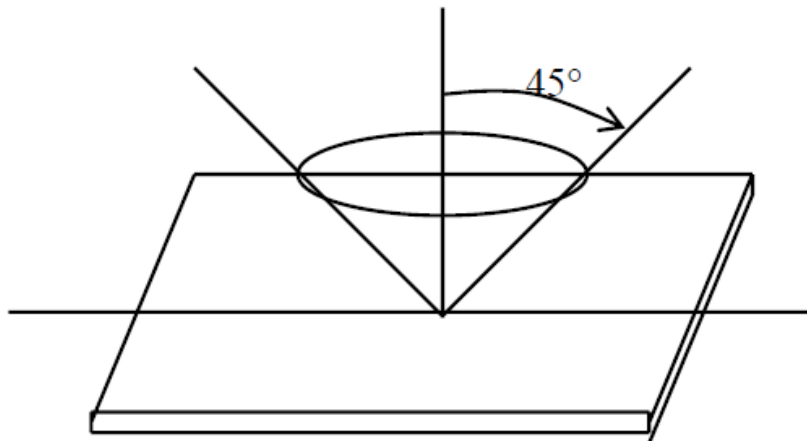

10. PRECAUTION RELATING PRODUCT HANDLING

10.1 SAFETY

10.1.1 If the LCD panel breaks , be careful not to get the liquid crystal to touch your skin.

10.1.2 If the liquid crystal touches your skin or clothes , please wash it off immediately by using soap and water.

10.2 HANDLING

10.2.1 Avoid any strong mechanical shock which can break the glass.

10.2.2 Avoid static electricity which can damage the CMOS LSI—When working with the module, be sure to ground your body and any electrical equipment you may be using.

10.2.3 Do not remove the panel or frame from the module.

10.2.4 The polarizing plate of the display is very fragile. So , please handle it very carefully, Do not touch, push or rub the exposed polarizing with anything harder than an HB pencil lead (glass , tweezers , etc.)

10.2.5 Do not wipe the polarizing plate with a dry cloth, as it may easily scratch the surface of plate.

10.2.6 Do not touch the display area with bare hands , this will stain the display area.

10.2.7 Do not use ketonics solvent & aromatic solvent. Use with a soft cloth soaked with a cleaning naphtha solvent.

10.2.8 To control temperature and time of soldering is $280 \pm 10^{\circ}\text{C}$ and 3-5 sec.

10.2.9 To avoid liquid (include organic solvent) stained on LCM.

10.3 STORAGE

10.3.1 Store the panel or module in a dark place where the temperature is $25^{\circ}\text{C} \pm 5^{\circ}\text{C}$ and the humidity is below 65% RH.

10.3.2 Do not place the module near organics solvents or corrosive gases.

10.3.3 Do not crush, shake, or jolt the module.



Стандарт Электрон Связь

Мы молодая и активно развивающаяся компания в области поставок электронных компонентов. Мы поставляем электронные компоненты отечественного и импортного производства напрямую от производителей и с крупнейших складов мира.

Благодаря сотрудничеству с мировыми поставщиками мы осуществляем комплексные и плановые поставки широчайшего спектра электронных компонентов.

Собственная эффективная логистика и склад в обеспечивает надежную поставку продукции в точно указанные сроки по всей России.

Мы осуществляем техническую поддержку нашим клиентам и предпродажную проверку качества продукции. На все поставляемые продукты мы предоставляем гарантию .

Осуществляем поставки продукции под контролем ВП МО РФ на предприятия военно-промышленного комплекса России , а также работаем в рамках 275 ФЗ с открытием отдельных счетов в уполномоченном банке. Система менеджмента качества компании соответствует требованиям ГОСТ ISO 9001.

Минимальные сроки поставки, гибкие цены, неограниченный ассортимент и индивидуальный подход к клиентам являются основой для выстраивания долгосрочного и эффективного сотрудничества с предприятиями радиоэлектронной промышленности, предприятиями ВПК и научно-исследовательскими институтами России.

С нами вы становитесь еще успешнее!

Наши контакты:

Телефон: +7 812 627 14 35

Электронная почта: sales@st-electron.ru

Адрес: 198099, Санкт-Петербург,
Промышленная ул, дом № 19, литера Н,
помещение 100-Н Офис 331