

ABX8X5 Real Time Clock Family

The ABX8XX Evaluation Kit provides all of the tools needed to assess the complete feature set in the ultra-low power AB08X5 and AB18X5 product families. The ABX8XX EVK is designed for easy integration via an I2C or SPI serial interface with microcontroller development kits or with custom boards. The ABX8XX EVK may be used for both initial evaluation and product development. This document provides an overview of the ABX8XX EVK and serves as a user's guide for fast setup. An image of the EVK development board is shown below.

The ABX8XX EVK Development Board

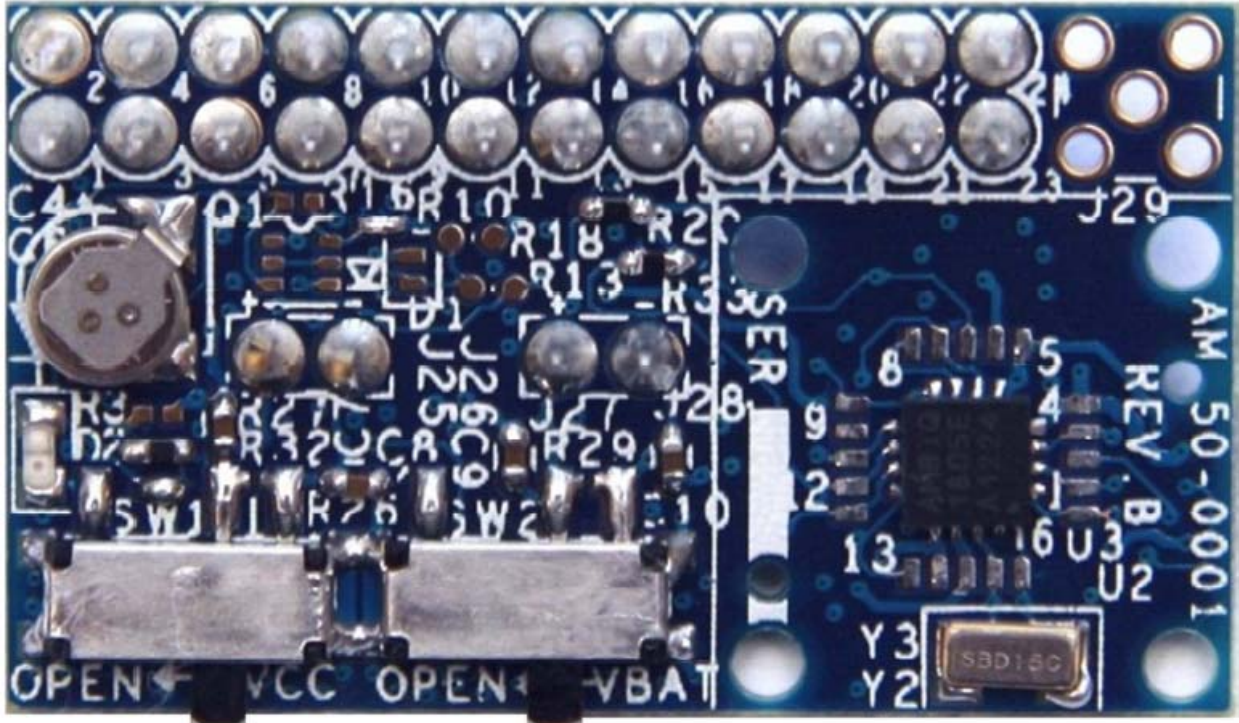

The versions of the ABX8XX EVK utilize the same printed circuit board but have different population options and support either I2C or SPI bus communication. The ABX8XX-I2C -EVK supports I2C communication. The ABX8XX-SPI-EVK supports SPI communication. The orderable part numbers are as follows:

Orderable Part Number	AB18X5 Device	Notes
ABX8XX-I2C-EVK	AB1805	I2C EVK Version
ABX8XX-SPI-EVK	AB1815	SP EVK Version

The ABX8XX-I2C-EVK and ABX8XX-SPI-EVK versions are populated with the AB1805 and AB1815 devices, respectively

Table of Contents

1. Kit Contents.....	3
2. ABX8XX EVK Overview.....	3
3. Component Locations.....	5
4. Connector Pin-outs and Probe Points.....	9
5. VCC and VBAT Current Measurements with SW1 and SW2.....	12
6. VBAT Backup Power.....	13
7. External 32kHz Clock.....	13
8. Debug LED.....	13
9. Installation Guide.....	13
9.1. Hardware Setup.....	13
9.2. Hardware Setup.....	14
9.3. Measuring Current Consumption of the ABX8XX EVK.....	14
9.4. Measuring Frequency Accuracy of the ABX8XX EVK.....	16
10. Schematics and Component List.....	17
11. Component Installation Differences.....	24
12. Notes.....	25
13. ABRACON LLC – TERMS & CONDITIONS OF SALE.....	25

Table of Tables

Table 1. Top Side Board Component Descriptions.....	5
Table 2. Bottom Side Board Component Descriptions.....	7
Table 3. 24-pin (2x12) Connector Pin Names and Descriptions.....	10
Table 4. ABX8XX-I2C-EVK Component List.....	22
Table 5. ABX8XX-SPI-EVK Component List.....	23
Table 6. Component Installation Differences.....	24

Table of Figures

Figure 1 AB18X5 EVK Block Diagram.....	4
Figure 2. EVK Board Top Side Components.....	5
Figure 3. EVK Board Bottom Side Components.....	6
Figure 4. Top Component Locations.....	7
Figure 5. Bottom Component Locations.....	8
Figure 6. 24-pin Header connector Pin-out.....	9
Figure 7. 5 x 5 Test point Array Pin-out.....	11
Figure 8. VCC and VBAT Current Measurement.....	12
Figure 9. ABX8XX-I2C-EVK Schematic Page 1.....	18
Figure 10. ABX8XX-I2C-EVK Schematic Page 2.....	19
Figure 11. ABX8XX-SPI-EVK Schematic Page 1.....	20
Figure 12. ABX8XX-SPI-EVK Schematic Page 2.....	21

1. Kit Contents

The items included in the ABX8XX EVK kit are listed below.

- Welcome letter
- One ABX8XX SPI or I2C EVK development board.
 - ABX8XX-I2C-EVK with I2C interface
 - ABX8XX-SPI-EVK with SPI interface
- USB flash-drive containing the following documentation.
 - ABX8XX Evaluation Kit User's Guide (this document)
 - AB08X5 Real Time Clock Family Datasheet
 - AB18X5 Real Time Clock Family with Power Management Datasheet
 - PCB Component Assembly Drawing - Searchable PDF file
 - PCB Layout Gerber Files
 - PCB Schematics - Searchable PDF file
 - AB18X5 Family System Power Management Application Note
 - ABX8X5 Using Low-Cost Ceramic Capacitors for RTC backup Application Note
 - Compiled and Tested C Code Driver Functions for the AB18X5 RTC Family
 - ABX8X5 Product Highlights

2. ABX8XX EVK Overview

The ABX8XX EVK should be used with a host microcontroller (e.g., a microcontroller development kit or an existing production system) to control memory reads and writes over the I2C or SPI serial interface. All operations can be initiated over the serial interface including setting time, reading time, setting alarms and timers, clearing alarms and timers, and other functions described in the datasheet documents "AB08X5 Real Time Clock Family" and "AB18X5 Real Time Clock Family with Power Management." In addition to serial interface access, the EVK provides access to all input and output signals on the AB18X5. These signals can be set or read by the host microcontroller unit (MCU) or any other component in the system. The AB18X5 RTC family members support either the I2C or SPI serial interface as well as different I/O and power management features.

The EVK also provides test points for making analog measurements. A pico-ammeter can be inserted in series with the VCC and VBAT supply voltages or between the PCB current measurement test points to measure the ultra-low current consumption in each of the oscillation modes. Additionally, a high accuracy frequency counter can be used to measure frequency stability over extended periods under different calibration settings.

Figure 1 shows a block diagram of a typical EVK use case.

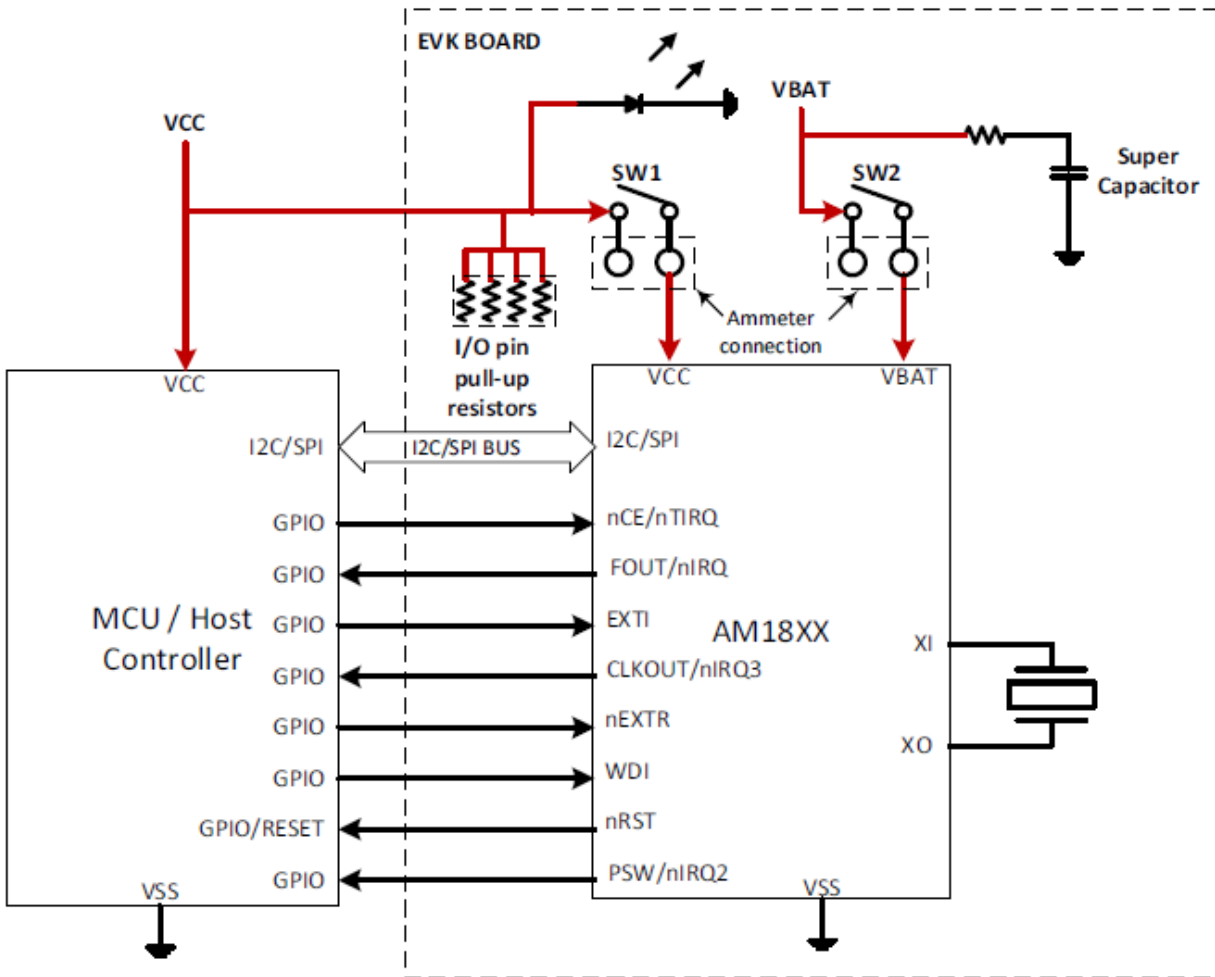

Figure 1 AB18X5 EVK Block Diagram

Access to all AB18X5 pins is provided by a 24-pin expansion header connector with 2mm x 2mm pin spacing. The EVK board also comes with 2-pin VCC and VBAT current measurement pins as shown in Figure 2.

3. Component Locations

This section describes key EVK board components and their locations on the top and bottom sides of the board. The top side EVK components are labeled in Figure 2 and are described in Table 1.

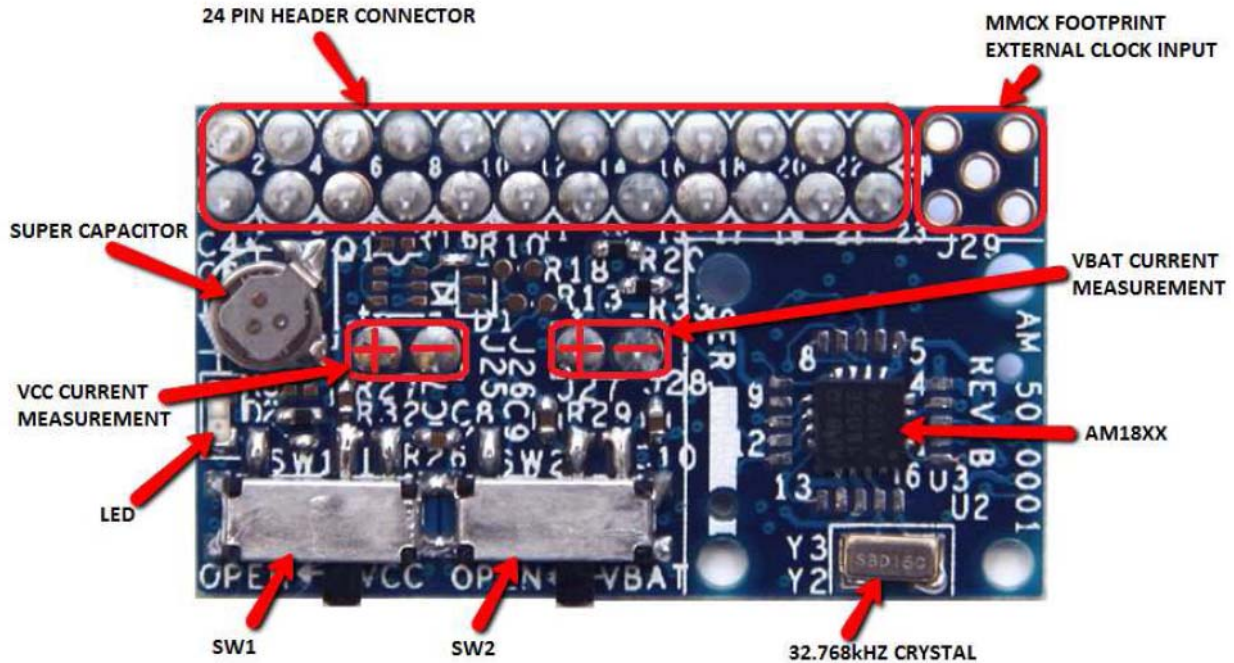

Figure 2. EVK Board Top Side Components

Table 1. Top Side Board Component Descriptions

Board Component	Description
24-pin header connector	This is the top side of the 24 pin connector used to make power and input/output pin signal connections to the EVK board. This is a 2x12, 2mm pitch connector (see EVK component list for part number). The connector can be used to connect to individual pin headers, ribbon cable connectors, or can be used as a module and plug into a female connector on the host target system.
Super Capacitor	Can be used as the VBAT (backup) supply power source of the AB18X5.
VCC current measurement pins	These pins are in series with the VCC supply pin of the AB18X5 and are used to connect to an external pico-ammeter for measuring the VCC current into the AB18X5 device. The connection polarity is shown in the diagram.
VBAT current measurement pins	These pins are in series with the VBAT supply pin of the AB18X5 and are used to connect to an external pico-ammeter for measuring the VBAT current into the AB18X5 device. The connection polarity is shown in the diagram.

Board Component	Description
LED	A separate pin on the 24-pin socket connector connects to the LED. This LED can be controlled by an MCU GPIO pin or can be connected directly to the VCC or VBAT supply to indicate one of the supplies has power applied.
SW1	This switch is connected in parallel with the VCC current measurement pins. It is used to short across the pins and connect the external VCC supply to the AB18X5 when not measuring current with the pico-ammeter.
SW2	This switch is connected in parallel with the VBAT current measurement pins. It is used to short across the pins and connect the external VBAT supply to the AB18X5 when not measuring current with the pico-ammeter.
32.768kHz crystal	The crystal is connected to the XI and XO pins of the AB18X5 device
AB18X5	I2C (AB1805) or SPI (AB1815) real time clock device.
MMCX footprint	This can be used for providing an external clock input.

The bottom side EVK components are labeled in Figure 3 and described in Table 2.

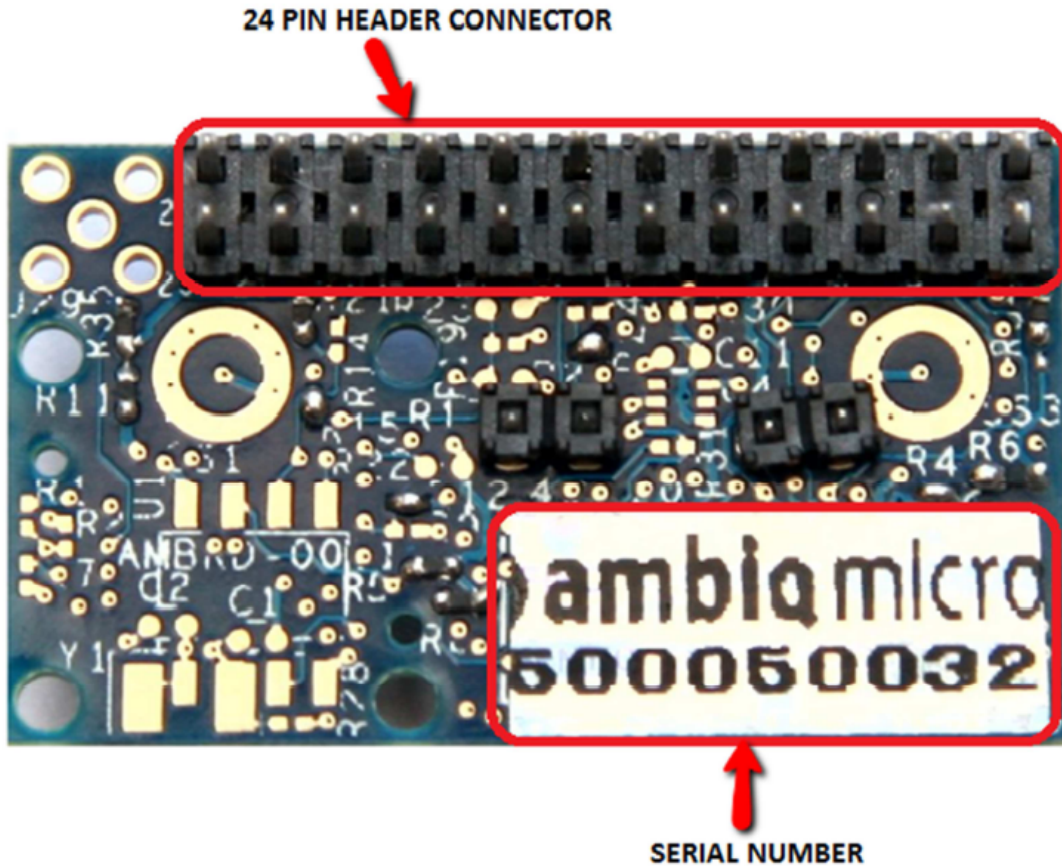

Figure 3. EVK Board Bottom Side Components

Table 2. Bottom Side Board Component Descriptions

Board Component	Description
24-pin socket connect	This is the bottom, male side of the connector used to make power and input/output pin signal connections to the EVK board. This is a 2x12, 2mm pitch connector (see EVK component list for part number). The male side of the connector can be used to connect to individual female socket pins, ribbon cable connectors, or can be used as a module and plug into a 2mm pitch female socket connector on the host MCU system.
Board serial number	A unique serial number assigned to each EVK board.

The top and bottom component locations and their corresponding reference designators are shown in Figure 4 and Figure 5. A searchable PDF file of the top and bottom board assembly drawings with reference designators is also included in the USB flash drive documentation to allow for quick location of components in the board schematics.

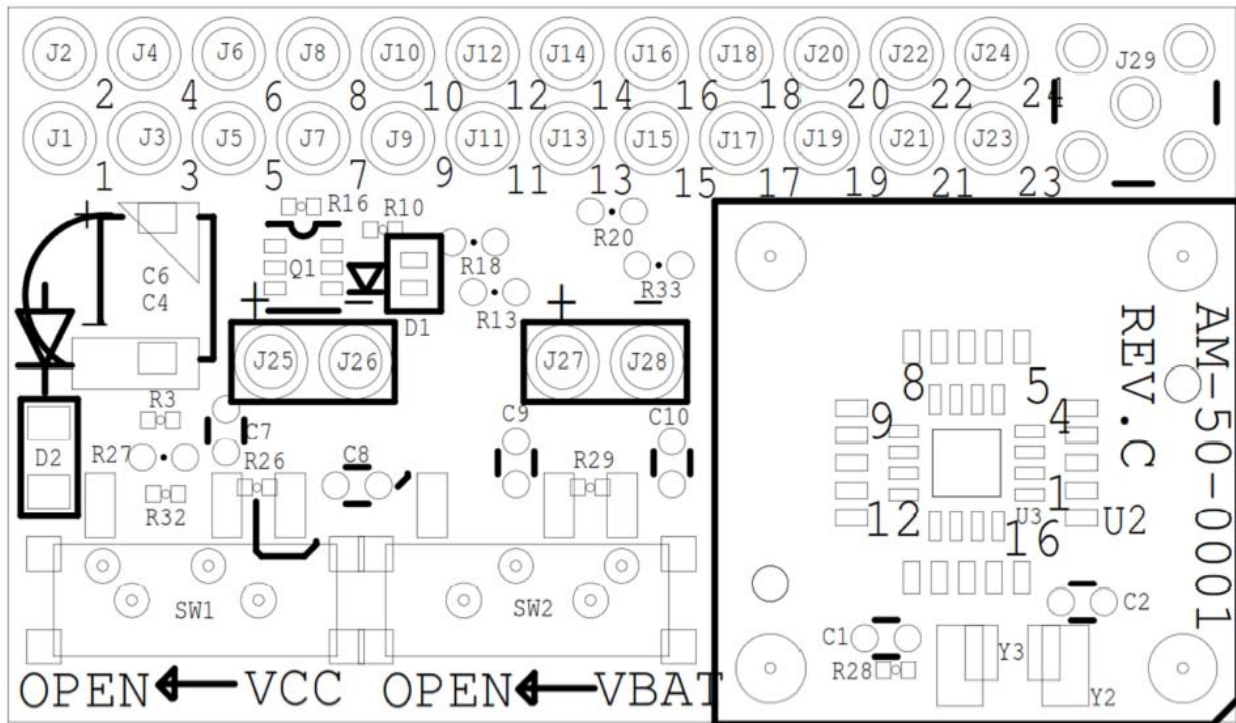

Figure 4. Top Component Locations

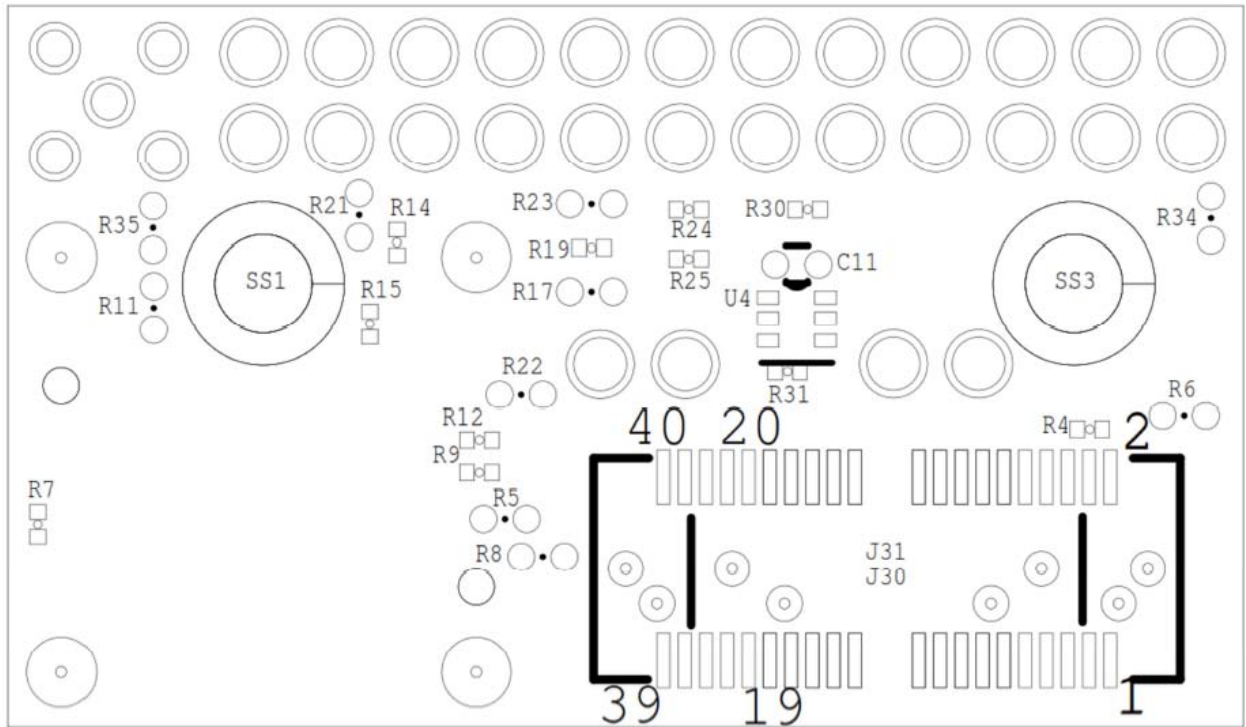

Figure 5. Bottom Component Locations

4. Connector Pin-outs and Probe Points

Figure 6 shows the location of the names and numbers each of the pins (pin-out) of the 24-pin header connector.

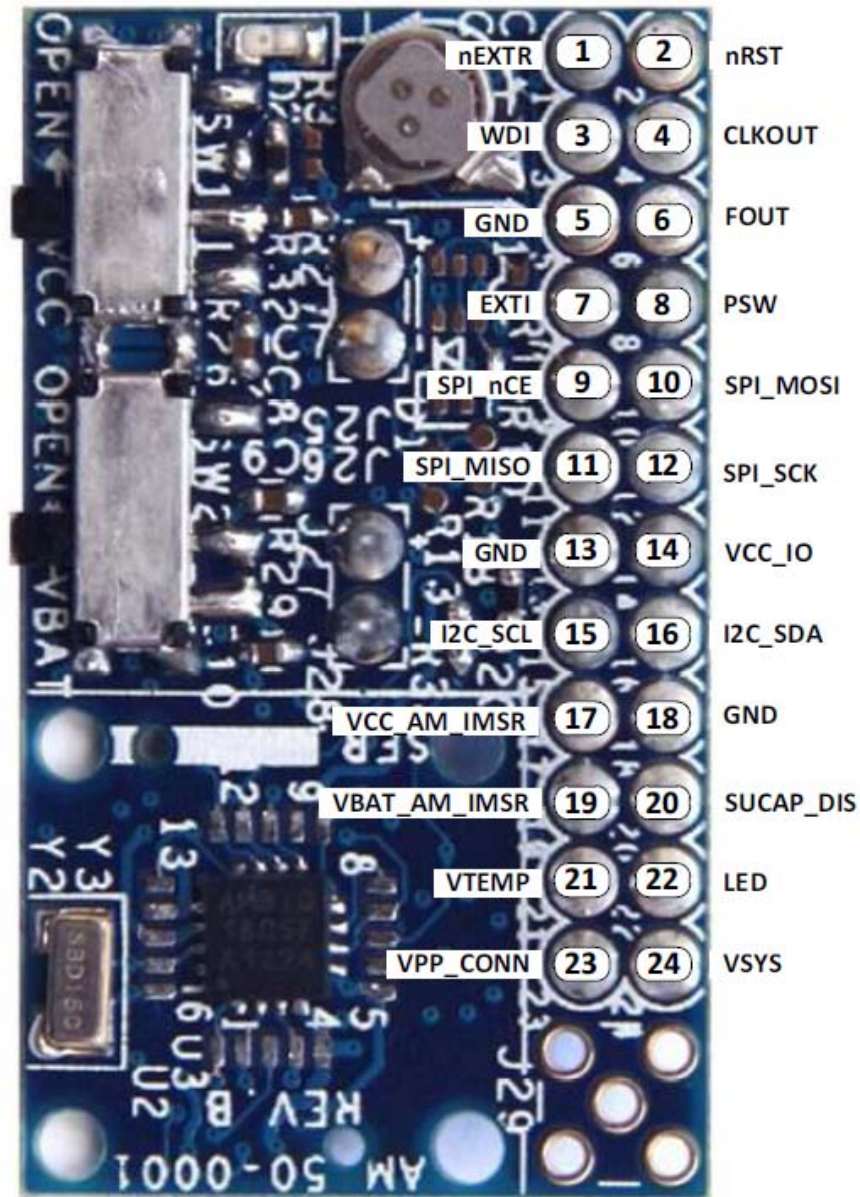

Figure 6. 24-pin Header connector Pin-out

Table 3 lists the numbers, names, and descriptions for each pin of the 24-pin (2x12) connector. There are also pull-up resistors on the board from the pin to the VCC_IO supply. Pull-up values are indicated in the table.

Table 3. 24-pin (2x12) Connector Pin Names and Descriptions

Pin No.	Pin Name	Board Pull-up Resistor	Description
1	nEXTR	10k	Connection to the external interrupt input pin (nEXTR) of the AB18X5.
2	nRST	10k	Connection to the external reset output pin (nRST) of the AB18X5.
3	WDI	10k	Connection to the watchdog timer reset input pin (WDI) of the AB18X5.
4	CLKOUT	--	Connection to the square wave output pin (CLKOUT) of the AB18X5.
5	GND	--	PCB GND connection. There is a single GND plane net for the PCB.
6	FOUT	10k	Connection to the primary interrupt output pin (FOUT/nIRQ) of the AB18X5. This pin can also be used to drive the AB18X5 square wave output.
7	EXTI	10k	Connection to the external interrupt input pin (EXTI) of the AB18X5.
8	PSW	10k	Connection secondary interrupt output pin (PSW/nIRQ2) of the AB18X5. It can also drive the square wave output or function as the power switch to power gate external devices.
9	SPI_nCE/ nTIRQ	10k	ABX8XX-I2C-EVK board: Connection to the timer output pin (nTIRQ) of the AB18X5. ABX8XX-SPI-EVK board: Connection to the I/O interface SPI chip select input pin (nCE) of the AB18X5.
10	SPI_MOSI	--	ABX8XX-I2C-EVK board: Not connected. ABX8XX-SPI-EVK board: SPI master out / slave in data signal. Connects to the I/O interface SPI data input pin (SDI) of the AB18X5.
11	SPI_MISO	--	ABX8XX-I2C-EVK board: Not connected. ABX8XX-SPI-EVK board: SPI master in / slave out data signal. Connects to the I/O interface SPI data output pin (SD0) of the AB18X5.
12	SPI_SCK	--	ABX8XX-I2C-EVK board: Not connected. ABX8XX-SPI-EVK board: Connects to the I/O interface clock pin (SCL) of the AB18X5. It provides the clock input for SPI interface mode.
13	GND	--	PCB GND connection. There is a single GND plane net for the PCB.
14	VCC_IO	--	This supply connection pin provides power to the board pull-up resistors and temperature sensor IC. The VCC_AM_IMSR and VCC_IO connector pins should be connected to the same voltage level.
15	I2C_SCL	2.2k	ABX8XX-I2C-EVK board: Connects to the I/O interface clock pin (SCL) of the AB18X5. It provides the clock input for I2C interface mode. ABX8XX-SPI-EVK board: Not connected.
16	I2C_SDA	2.2k	ABX8XX-I2C-EVK board: Connects to the I2C interface data I/O pin (SDA) of the AB18X5. ABX8XX-SPI-EVK board: Not connected.
17	VCC_AM_ImSR	--	This supply connection pin provides power to VCC supply pin of the AB18X5 through SW1. The VCC_AM_IMSR and VCC_IO connector pins should be connected to the same voltage level.
18	GND	--	PCB GND connection. There is a single GND plane net for the PCB.

Pin No.	Pin Name	Board Pull-up Resistor	Description
19	VBAT_AM_IMSR	--	This supply connection pin provides power to VBAT supply pin of the AB18X5 through SW2. It can be used to provide the backup power source to the AB18X5.
20	SUCAP_DIS	--	Super capacitor disconnect signal. This signal can be used to connect/disconnect the super capacitor from the AB18X5 VBAT pin. Additional component population changes are required to use this feature.
21	VTEMP	--	This is the analog voltage output from the temperature sensor IC on the board. The temperature sensor IC is not populated on the board by default.
22	LED	--	This pin connects to the debug LED populated on the board through a 510 ohm resistor.
23	VSYS	--	Test point
24	VPP_CON	--	Test point

A 5 x 5 array of probe points for the AB18X5 device is provided on the EVK board around the perimeter of the device package as shown in Figure 7. This enables users to probe or connect wires to the pins of the AB18X5 device for test and debug.

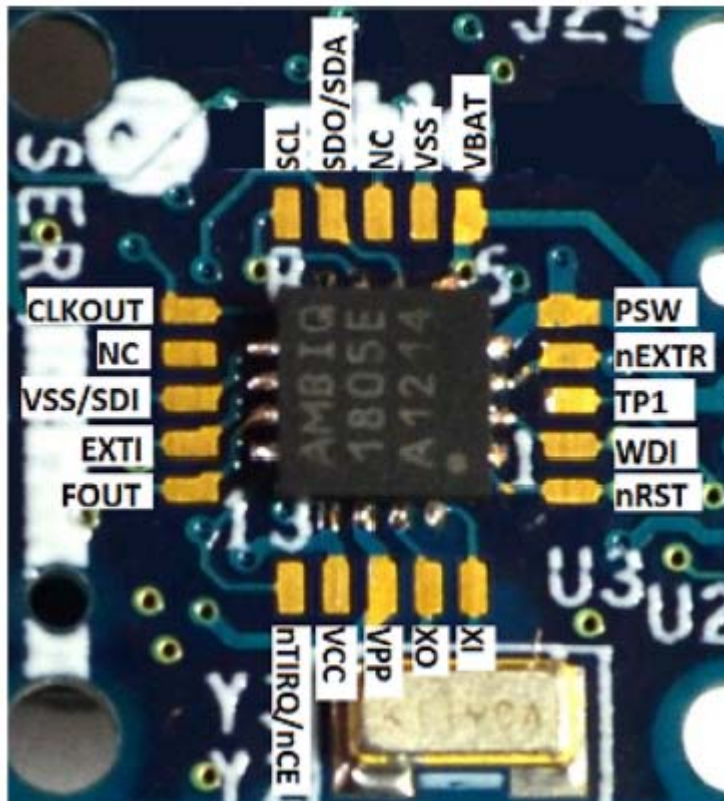

Figure 7. 5 x 5 Test point Array Pin-out

5. VCC and VBAT Current Measurements with SW1 and SW2

The AB18X5 VCC and VBAT supply current can be measured by connecting an ammeter to the VCC and VBAT current measurement pins. The VCC and VBAT current measurement pins and +/- polarity are shown in Figure 2. SW1 is connected across the + and – terminals of the VCC current measurement pins and SW2 is connected across the + and – terminals of the VBAT current measurement pins.

SW1 and SW2 are placed in the “open” position by sliding the switch lever to the left side as shown in Figure 8. They are placed in the “closed” position by sliding the switch lever to the right side.

When the switch is placed in the “open” position, the VCC/VBAT connection to the AB18X5 device becomes an open circuit. This forces current to flow through the VCC/VBAT current measurements pins and enables current measurement with an ammeter. When the switch is placed in the “closed” position, a short circuit is placed across the terminals of the VCC/VBAT current measurement pins. If an ammeter is still connected, its terminals will also get shorted together. This allows the ammeter to be removed from the VCC/VBAT current measurement pins without losing power to the AB18X5 device. If an ammeter is not connected to the VCC/VBAT current measurement pins, the switch should be placed in the “closed” position to supply power to the AB18X5 device from the 24-pin connector.

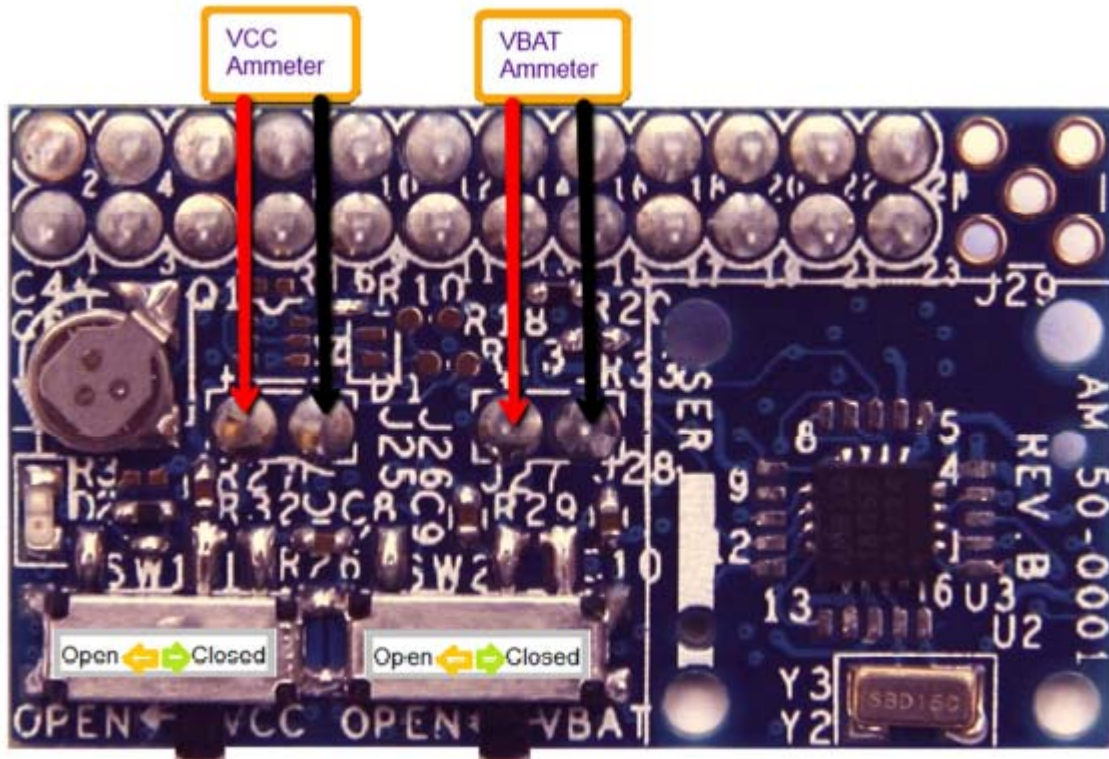

Figure 8. VCC and VBAT Current Measurement

6. VBAT Backup Power

Backup power to the AB18X5 VBAT pin can be provided using the 24-pin connector or the on-board super capacitor. The super capacitor can be connected to the VBAT pin of the AB18X5 by populating 0 ohm resistors or solder shorts across R10 and R16. This will allow continued time keeping, register/memory state retention, etc. should the VCC supply be removed. Information about using the AB18X5 integrated trickle charger to charge the super capacitor can be found in the datasheet document “AB18X5 Real Time Clock Family with Power Management.”

7. External 32kHz Clock

An external 32.768 kHz clock can be supplied to the AB18X5 device via the MMCX connector footprint shown in Figure 2. The middle pin of this connector footprint connects to the XO pin of the AB18X5 device. An MMCX connector or other can be soldered to these pins to connect to an external frequency generator. The external clock must not exceed either the VCC supply or 1.8V (maximum input voltage), whichever is less.

To connect the MMCX connector to the XO pin of the AB18X5 device, remove the crystal from the board and populate R28 with a 0 ohm resistor or solder short.

8. Debug LED

A debug/indicator LED is provided on the board and has an individual pin connection to the 24 pin connector. There is a 510 ohm resistor in series with the LED with the cathode of the LED connected to GND. The LED can be connected directly to the VCC_IO supply to indicate when power is supplied to the board or it can be connected to an MCU GPIO pin.

9. Installation Guide

9.1. Hardware Setup

1. Begin with the ABX8XX EVK and HC development boards powered down.
2. For the ABX8XX-I2C-EVK, connect the I2C_SDA (pin 16) and I2C_SCL (pin 15) pins on the EVK 24 pin connector to the SDA and SCL pins on the HC development board. For the ABX8XX-SPI-EVK, connect the SPI_SCK (pin 12), SPI_MISO (pin 11), SPI_MOSI (pin 10) and SPI_nCE/nTIRQ (pin 9) pins on the EVK connector to the corresponding pins on the HC development board.
3. Connect any other digital inputs/outputs of interest on the ABX8XX EVK development board connector to GPIO pins on the HC.
4. Connect the VCC, VBAT (if applicable), and VSS pins on the EVK connector to appropriate supply voltages. The VCC supply voltage should be connected to both VCC_AM_IMSR (pin 17) and VCC_IO (pin 14) (see Figure 6). The VBAT supply voltage should be connected to VCC_AM_IMSR (pin 19). The HC VCC and AB18X5 VCC supplies should be the same voltage.
5. Power up the ABX8XX EVK and HC development boards.

9.2. Hardware Setup

The ABX8XX EVK does not require any host PC software installation but does require minimal driver development for the HC. All drivers are simple sequences of I2C or SPI register writes. Detailed information on each register in the ABX8X5 products can be found in the datasheet documents titled, “AB08X5 Real Time Clock Family” and “AB18X5 Real Time Clock Family with Power Management.”

C language driver code and functions for the ABX8X5 RTC family are included in separate files on the USB flash drive titled “ABX8X5.c” and “ABX8X5.h”. These ABX8X5 C language driver functions were compiled and tested using TI Code Composer Studio version 5.2.1 for the MSP430G2553 processor. They can be used to evaluate the features of the ABX8X5 RTC. The customer may choose to substantially reduce the size of the driver functions dependent upon MCU code space requirements and the ABX8X5 features being used.

The MCU C functions below are used in the ABX8X5.c file. The implementation of these functions will be specific to the processor being used in the application. The customer should develop these driver functions for their target MCU. Below are the function prototypes.

// I2C Interface Functions

```
void mcu_i2c_write(uint8_t num_bytes, uint8_t addr, uint8_t * data);  
void mcu_i2c_read(uint8_t num_bytes, uint8_t addr, uint8_t * data);  
void mcu_i2c_init(uint8_t slave_addr);
```

// SPI Interface Functions

```
void mcu_spi_init(void);  
void mcu_spi_read(uint8_t num_bytes, uint8_t addr, uint8_t * data);  
void mcu_spi_write(uint8_t num_bytes, uint8_t addr, uint8_t * data);
```

num_bytes = # of bytes to read or write to the ABX8X5

addr = ABX8X5 register or memory address

* data = pointer to the first byte of data in the array or the address of the array containing the read/write data.

9.3. Measuring Current Consumption of the ABX8XX EVK

To measure current draw on the ABX8XX EVK, an ammeter must be inserted in series with the AB18X5 part, and the part must then be put into a desired oscillation state. Listed below are the steps required to measure current through the AB18X5 VCC pin in the most energy-efficient setting in crystal (XT) oscillation and RC oscillation modes.

1. Complete Steps 1-4 in Section 9.1.
2. Connect an ammeter in series with the VCC pin on the AB18X5 part. This is done most easily by first connecting an ammeter between the VCC current measurement pins (see Figure 8). Power on the ammeter and set it to a range setting capable of measuring mA or tens of mA. To measure positive current, the ammeter polarity should be connected following the VCC Current Measurement polarity markers (+/-) shown in Figure 2. Once the ammeter is connected, change the position of SW1 to the open position (see Figure 8).
3. Power up the ABX8XX EVK and HC development boards.

4. Issue a series of commands to place the AB18X5 part in a typical low current oscillation state. The examples here use the I/O access functions readreg and writereg described in the pseudo code.

- a. Set the OUT bit (register 0x10 bit 4) to 1 and the OUT1S field (register 0x11 bits [1:0]) to 0 to ensure the FOUT pin is high and not drawing current through the pull-up resistor. Set the OUTB bit (register 0x10 bit 5) to 1 and the OUT2S field (register 0x11 bits [4:2]) to 0 to ensure the OUT2 pin is high and not drawing current through the pull-up resistor. Set the RS1E bit (register 0x11 bit 5) to 0 to disable the external reset input. This should force the nRST pin to be high and not draw current through the pull-up resistor.

```
temp = readreg(0x10)           // Read the Control1 Register
writereg(0x10, temp | 0x30)    // Set the OUT and OUTB bits
temp = readreg(0x11)           // Read the Control2 Register
writereg(0x11, temp & 0xC0)    // Set the OUT1S, OUT2S and RS1E fields to 0
```

- b. Set the IM field (register 0x12 bits [6:5]) to 0x3. This will minimize the current drawn by the alarm interrupt pulse generator.

```
temp = readreg(0x12)           // Read the Interrupt Mask Register
writereg(0x12, temp | 0x60)    // Set the IM field to 0x3
```

- c. Set the TE bit low and the TFS field to 0x3 by writing the value 0x03 to register 0x18. This will minimize internal current drawn by the Countdown Timer and ensure the OUT3 pin is high and not drawing current through the pull-up resistor.

```
writereg(0x13, 0x03)           // Set the TE bit to 0 and the TFS field to 0x3
```

- d. Set the SQWE bit (register 0x13 bit 7) to 0 to disable the output square wave generator and ensure that the OUT4 pin is not toggling.

```
temp = readreg(0x13)           // Read the SQW Register
writereg(0x13, temp & 0x7F)    // Set the SQWE bit to 0
```

- e. To observe the current with the Crystal oscillator running, set the OSEL bit (register 0x1C bit 7) to 0. Note that register 0x1F MUST be written with the value 0xA1 prior to any attempt to modify register 0x1C.

```
temp = readreg(0x1C)           // Read the Oscillator Control Register
writereg(0x1F, 0xA1)           // Load the Configuration Key Register with 0xA1
writereg(0x1C, temp & 0x7F)    // Set the OSEL bit to 0
```

- f. To observe the current with the RC oscillator running, set the OSEL bit (register 0x1C bit 7) to 1. Note that register 0x1F MUST be written with the value 0xA1 prior to any attempt to modify register 0x1C.

```
temp = readreg(0x1C)           // Read the Oscillator Control Register
writereg(0x1F, 0xA1)           // Load the Configuration Key Register with 0xA1
writereg(0x1C, temp | 0x80)    // Set the OSEL bit to 1
```

- g. The calendar counter registers (registers 0x0 through 0x7) may be read to verify that the internal timing system is operational.

5. Change the ammeter range to a setting capable of measuring nA and observe the current draw. Averaging and filtering functions can help eliminate minor fluctuations in current caused by environmental radiation.

Note that nA current measurements can be influenced by both environmental conditions and equipment selection. Contact Abracon support at tech-support@abracon.com with any questions about measurement conditions.

9.4. Measuring Frequency Accuracy of the ABX8XX EVK

To measure frequency accuracy on the ABX8XX EVK, a high-precision universal counter should be used to monitor the frequency output on the CLKOUT pin. Follow the steps below to achieve a high accuracy reading in crystal (XT) oscillation mode, RC oscillation mode, or autocalibration mode.

1. Complete Steps 1-4 in Section 9.1.
2. Connect a universal counter to Pin 4 of the 24-pin expansion connector in Figure 6. Choose a long integration time on the universal counter (e.g., 10 seconds) to ensure that a sufficient number of clock periods are captured.
3. Power up the ABX8XX EVK and HC development boards.
4. Place the AB18X5 part in a typical oscillation state by setting the SQWE bit (register 0x13 bit 7) to 1, and the SQFS field (register 0x13 bits [4:0]) to select a low frequency used to measure the internal oscillation modes. A frequency of 1 Hz (SQFS = 0xF) allows easy interpretation of the frequency error.

```
writereg(0x13, 0x8F) // Set the SQWE bit to 1 and the SQFS field to 0xF
```

5. Note that if the AB18X5 is driving an external clock signal, the current drawn will be significantly higher than the current observed in low power mode.
6. Observe the frequency reported by the universal counter. For short integration times, the frequency may appear to fluctuate for the RC oscillator, in particular. This is a result of calibration and does not affect long term accuracy. Record frequency measurements over extended periods of hours or days to achieve the most accurate data.
 - a. To observe the Crystal oscillator, set the OSEL bit (register 0x1C bit 7) to 0. Note that register 0x1F MUST be written with the value 0xA1 prior to any attempt to modify register 0x1C.

```
temp = readreg(0x1C) // Read the Oscillator Control Register  
writereg(0x1F, 0xA1) // Load the Configuration Key Register with 0xA1  
writereg(0x1C, temp & 0x7F) // Set the OSEL bit to 0
```

- b. To observe the RC oscillator, set the OSEL bit (register 0x1C bit 7) to 1. Note that register 0x1F MUST be written with the value 0xA1 prior to any attempt to modify register 0x1C.

```
temp = readreg(0x1C) // Read the Oscillator Control Register  
writereg(0x1F, 0xA1) // Load the Configuration Key Register with 0xA1  
writereg(0x1C, temp | 0x80) // Set the OSEL bit to 1
```

- c. To observe the RC oscillator while autocalibration is active, set the OSEL bit (register 0x1C bit 7) to 1 and the ACAL field (register 1C bits [6:5]) to 0x3. Note that register 0x1F MUST be written with the value 0xA1 prior to any attempt to modify register 0x1C. This will enable autocalibration of the RC oscillator to occur every 512 seconds (roughly every 8.5 minutes). The first autocalibration cycle will begin as soon as ACAL is set to 0x3, and will be completed with a new RC calibration value in the CALRC registers (registers 0x15 and 0x16) within 60 seconds.

```
temp = readreg(0x1C) // Read the Oscillator Control Register
temp = temp & 0x9F // Mask the ACAL field
writereg(0x1C, temp | 0x60) // Set the OSEL bit to 1 and the ACAL field to 0x2
```

Note that frequency accuracy measurements are heavily influenced by test equipment. Contact Abracon support at tech-support@abracon.com with any questions about proper test setup.

10. Schematics and Component List

Figure 9 and Figure 10 below show the two pages of the ABX8XX-I2C-EVK board schematics. Figure 11 and Figure 12 show the two pages of the ABX8XX-SPI-EVK board schematics. Table 4 shows the ABX8XX-I2C-EVK board component list and Table 5 shows the ABX8XX-SPI-EVK board component list. Board components labeled as DNP (do not populate) in the schematics are not installed on the board.

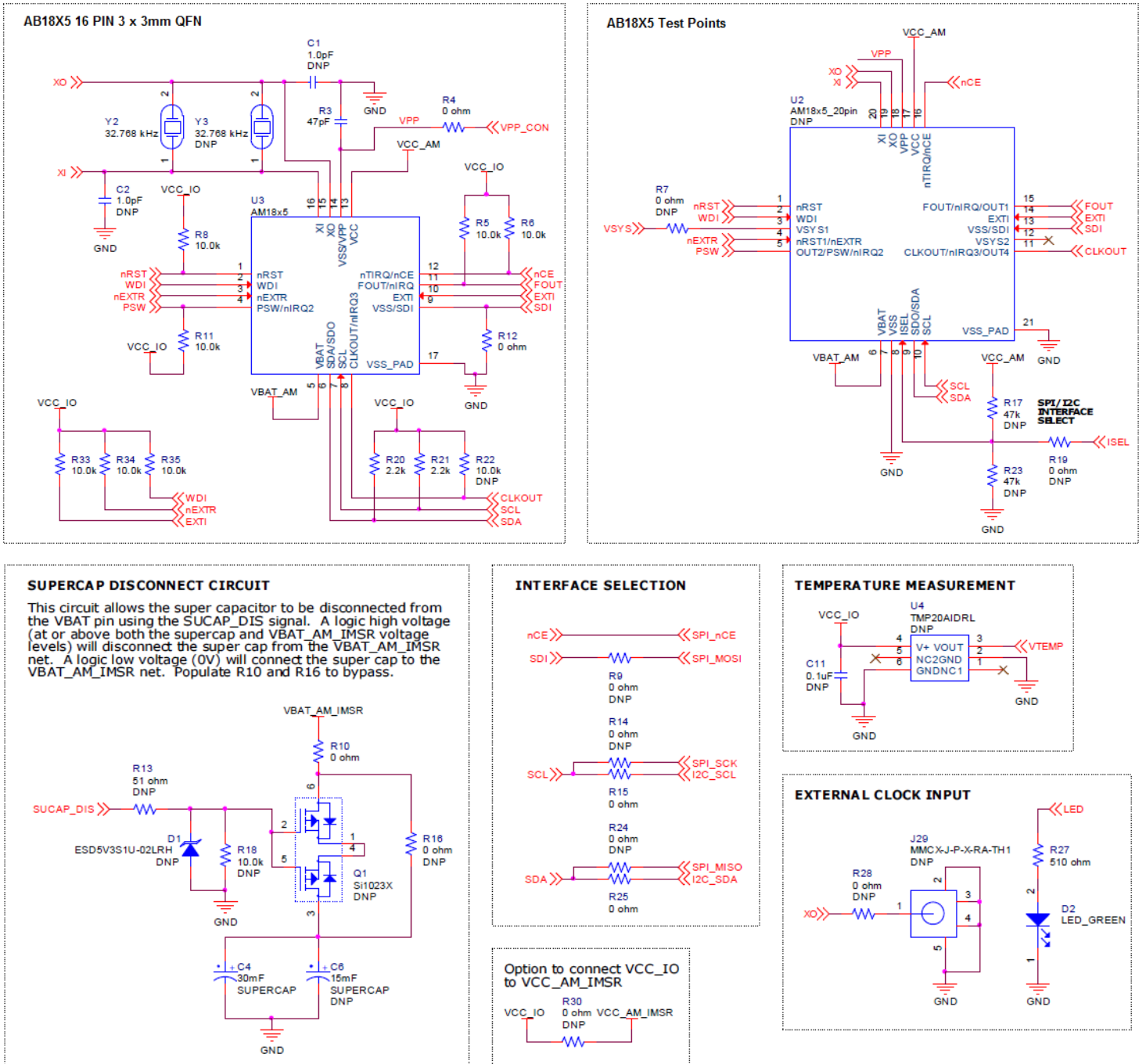

Figure 9. ABX8XX-I2C-EVK Schematic Page 1

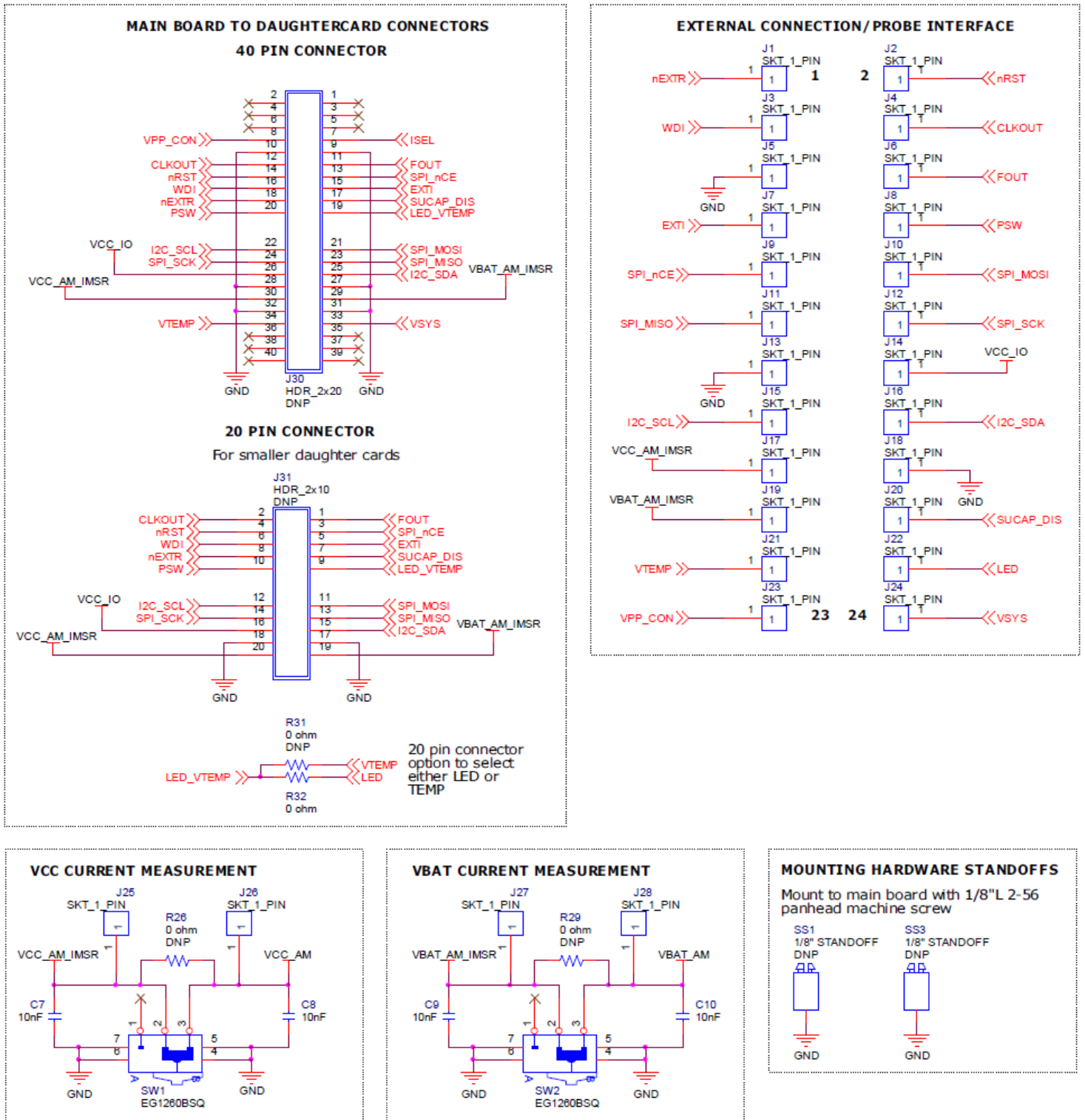

Figure 10. ABX8XX-I2C-EVK Schematic Page 2

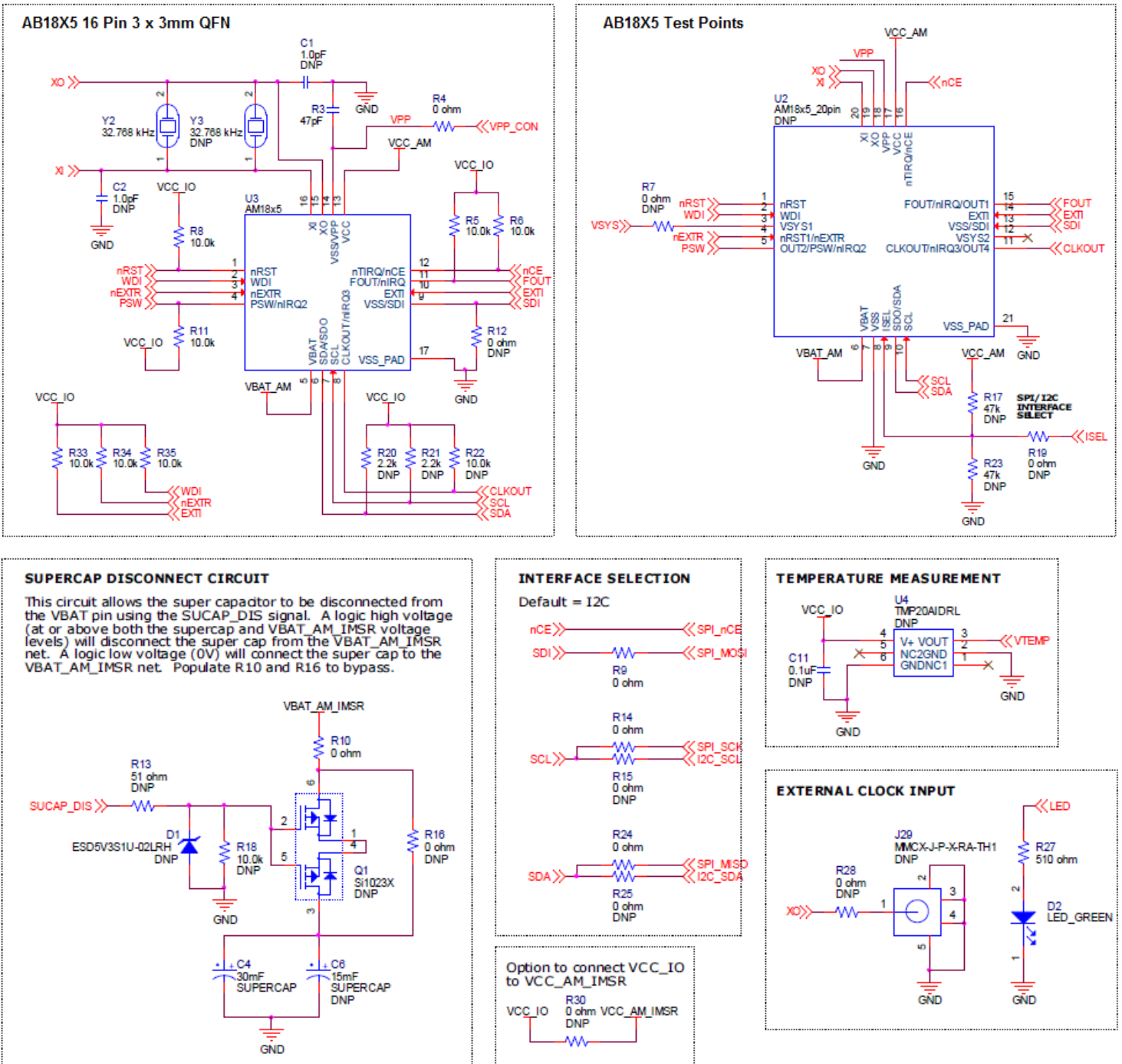

Figure 11. ABX8XX-SPI-EVK Schematic Page 1

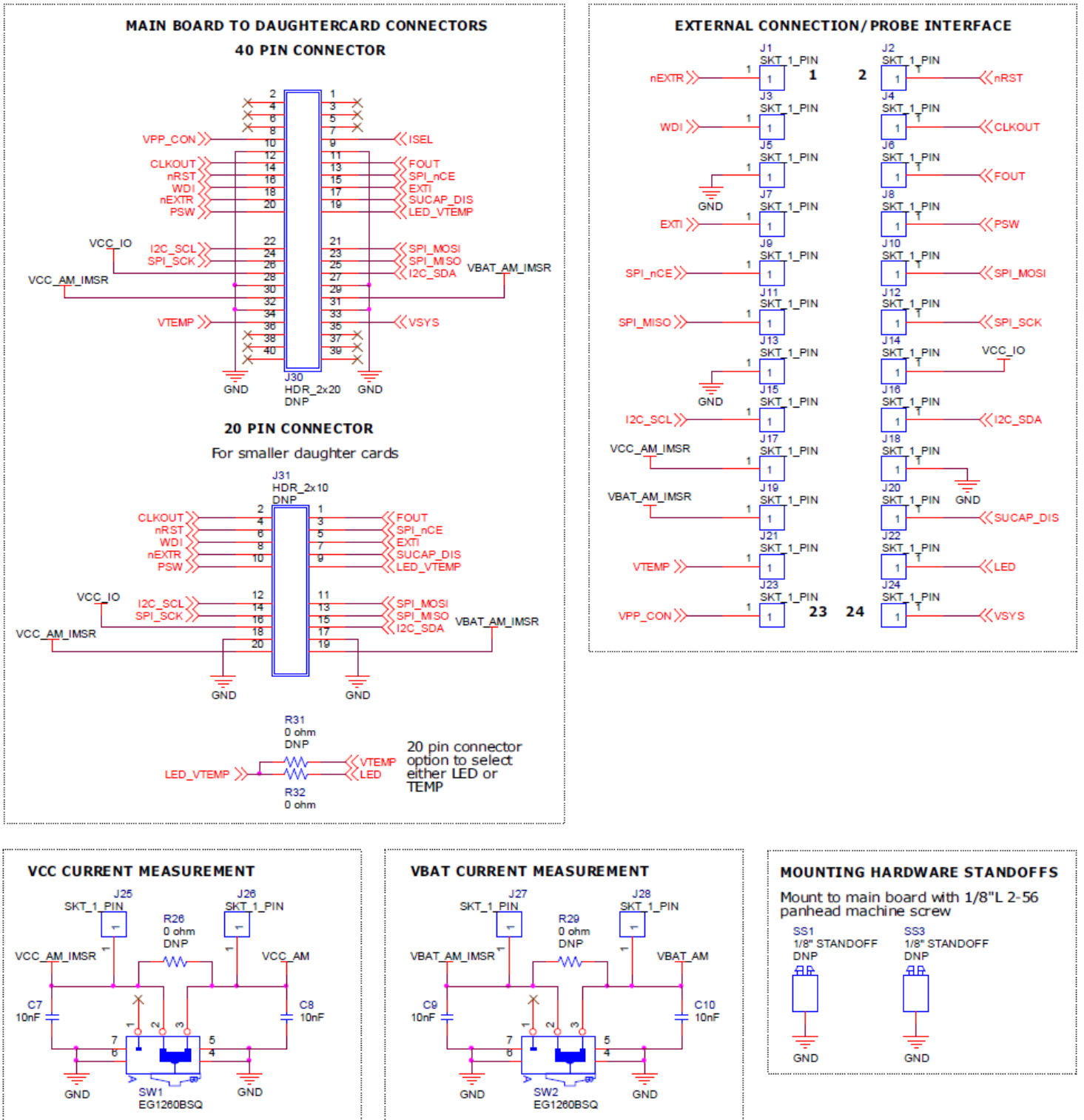

Figure 12. ABX8XX-SPI-EVK Schematic Page 2

Table 4. ABX8XX-I2C-EVK Component List

Item	Qty	Reference	Part	MFG_Name	MFG_PN	Description
1	1	C4	30mF	TAIYO YUDEN	PAS311HR-VG1	30mF super capacitor
2	4	C7,C8, C9,C10	10nF	TAIYO YUDEN	TMK105B7103KV-F	ceramic capacitor
3	1	D2	LED_GREEN	OSRAM	LG L29K-G2J1-24-Z	green LED
4	2	J25,J25,J27,J28	SKT_1_PIN	SAMTEC	MTMM-102-02-L-S-195	two pin header
5	4	R5,R6,R8,R11, R33,R34,R35	10.0k	PANASONIC	ERJ-2GE0R00C	0402 size 10k ohm
6	3	R4,R10,R12, R15,R25,R32	0 ohm	PANASONIC	ERJ-1GE0R00C	resistor/jumper
7	2	R20,R21	2.2k	PANASONIC	ERJ-2RKF2201X	0402 size 2.2k ohm
8	1	R27	510 ohm	PANASONIC	ERJ-2RKF5100X	0402 size 512 ohm
9	2	SW2,SW1	EG1260AS	E SWITCH	EG1260AS	slide switch
10	1	Y2	32.768kHz	ABRACON	ABS07-32.768kHz-7-T	3.2x1.5mm, 7pF, 32.768kHz crystal
11	1	J1,J2,J3,J4,J5,J6,J7,J8,J9, J10,J11,J12,J13,J14,J15, J16,J17,J18,J19,J20,J21, J22,J23,J24	SKT_1_PIN	SAMTEC	MTMM-112-05-L-D-200	2mm pin headers, 2x12
12	1	U3	AB1805	ABRACON	AB1805	AB1805 16 pin QFN
13	1	R3	47pF	TAIYO YUDEN	UMK105CG470JV-F	0402 size 47pF
Components Not Installed						
1	2	C2,C1	1.0pF	MURATA	GRM1555C1H1R2CZ01D	1.0pF ceramic cap
2	1	C6	15mF	PANASONIC	EEC-ER0E153	30mF super capacitor
3	1	C11	0.1µF	MURATA	GRM155F50J104ZA01D	0.1µF ceramic cap
4	1	D1	ESD5V3S1U-02LRH	INFINEON TECH.	ESD5V3S1U-02LRH-E6327	5.3V TVS diode
5	1	J29	MMCX-J-P-X-RA-TH1	SAMTEC	MMCX-J-P-X-RA-TH1	right angle MMCX
6	1	J30	HDR_2X20	SAMTEC	LTH-020-01-G-D-A	Samtec 2x20 low profile connector
7	1	J31	HDR_2X10	SAMTEC	LTH-010-01-G-D-A	Samtec 2x10 low profile connector
8	1	Q1	Si1023X	VISHAY SILICONIX	SI1023X-T1-GE3	low leakage PFET
9	11	R7,R9,R14,R16,R19,R24, R26,R28,R29,R30,R31	0 ohm	PANASONIC	ERJ-1GE0R00C	
10	1	R13	51 ohm	VISHAY	CRCW040251R01FKED	resistor/jumper
11	2	R17,R23	47k	YAGEO	RC0402FR-0747KL	0402 size 47k ohm
12	2	R18,R22	10.0k	YAGEO	RC0402FR-0710KL	0402 size 10k ohm
13	2	SS1,SS3	1/8" STANDOFF	RAF ELECTRONIC HARDWARD	1600A-256-B	round threaded standoff
14	1	U2	TEST POINTS	N/A	N/A	
15	1	U4	TMP20AIDRL	TEXAS INSTRUMENTS	TMP20AIDRLT	temperature sensor
16	1	Y3	32.768kHz	ABRACON	ABS06-32.768kHz-9-T	2.0x1.2mm, 9pF, 32.768kHz crystal

Table 5. ABX8XX-SPI-EVK Component List

Item	Qty	Reference	Part	MFG_Name	MFG_PN	Description
1	1	C4	30mF	TAIYO YUDEN	PAS311HR-VG1	30mF super capacitor
2	4	C7,C8, C9,C10	10nF	TAIYO YUDEN	TMK105B7103KV-F	ceramic capacitor
3	1	D2	LED_GREEN	OSRAM	LG L29K-G2J1-24-Z	green LED
4	2	J25,J25,J27,J28	SKT_1_PIN	SAMTEC	MTMM-102-02-L-S-195	two pin header
5	4	R5,R6,R8,R11, R33,R34,R35	10.0k	PANASONIC	ERJ-2GE0R00C	0402 size 10k ohm
6	3	R4,R9,R10, R14,R24,R32	0 ohm	PANASONIC	ERJ-1GE0R00C	resistor/jumper
7	1	R27	510 ohm	PANASONIC	ERJ-2RKF5100X	0402 size 512 ohm
8	2	SW2,SW1	EG1260AS	E SWITCH	EG1260AS	slide switch
9	1	Y2	32.768kHz	ABRACON	ABS07-32.768kHz-7-T	3.2x1.5mm, 7pF, 32.768kHz crystal
10	1	J1,J2,J3,J4,J5,J6,J7,J8,J9, J10,J11,J12,J13,J14,J15, J16,J17,J18,J19,J20,J21, J22,J23,J24	SKT_1_PIN	SAMTEC	MTMM-112-05-L-D-200	2mm pin headers, 2x12
11	1	U3	AB1815	ABRACON	AB1815	AB1815 16 pin QFN
12	1	R3	47pF	TAIYO YUDEN	UMK105CG470JV-F	0402 size 47pF
Components Not Installed						
1	2	C2,C1	1.0pF	MURATA	GRM1555C1H1R2CZ01D	1.0pF ceramic cap
2	1	C6	15mF	PANASONIC	EEC-ER0E153	30mF super capacitor
3	1	C11	0.1µF	MURATA	GRM155F50J104ZA01D	0.1µF ceramic cap
4	1	D1	ESD5V3S1U-02LRH	INFINEON TECH.	ESD5V3S1U-02LRH-E6327	5.3V TVS diode
5	1	J29	MMCX-J-P-X-RA-TH1	SAMTEC	MMCX-J-P-X-RA-TH1	right angle MMCX
6	1	J30	HDR_2X20	SAMTEC	LTH-020-01-G-D-A	Samtec 2x20 low profile connector
7	1	J31	HDR_2X10	SAMTEC	LTH-010-01-G-D-A	Samtec 2x10 low profile connector
8	1	Q1	Si1023X	VISHAY SILICONIX	SI1023X-T1-GE3	low leakage PFET
9	11	R7,R12,R15,R16,R19, R25,R26,R28,R29,R30, R31	0 ohm	PANASONIC	ERJ-1GE0R00C	
10	1	R13	51 ohm	VISHAY	CRCW040251R01FKED	resistor/jumper
11	2	R17,R23	47k	YAGEO	RC0402FR-0747KL	0402 size 47k ohm
12	2	R18,R22	10.0k	YAGEO	RC0402FR-0710KL	0402 size 10k ohm
13	2	SS1,SS3	1/8" STANDOFF	RAF ELECTRONIC HARDWARD	1600A-256-B	round threaded standoff
14	1	U2	TEST POINTS	N/A	N/A	
15	1	U4	TMP20AIDRL	TEXAS INSTRUMENTS	TMP20AIDRLT	temperature sensor
16	2	R20,R21	2.2k	PANASONIC	ERJ-2RKF2201X	0402 size, 2.2k ohm
17	1	Y3	32.768kHz	ABRACON	ABS06-32.768kHz-9-T	2.0x1.2mm, 9pF, 32.768kHz crystal

11. Component Installation Differences

Table 6 lists the component installation differences between the ABX8XX-I2C-EVK and ABX8XX-SPI-EVK boards.

Table 6. Component Installation Differences

Component	ABX8XX-I2C-EVK Board	ABX8XX-SPI-EVK Board
R12,R15,R20,R21,R25	Installed	Not installed
R9,R14,R24	Not installed	Installed

12. Notes

- i) The parts are manufactured in accordance with this specification. If other conditions and specifications which are required for this specification, please contact ABRACON for more information.
- ii) ABRACON will supply the parts in accordance with this specification unless we receive a written request to modify prior to an order placement.
- iii) In no case shall ABRACON be liable for any product failure from in appropriate handling or operation of the item beyond the scope of this specification.
- iv) When changing your production process, please notify ABRACON immediately.
- v) ABRACON's products are COTS – Commercial-Off-The-Shelf products; suitable for Commercial, Industrial and, where designated, Automotive Applications. ABRACON's products are not specifically designed for Military, Aviation, Aerospace, Life-dependant Medical applications or any application requiring high reliability where component failure could result in loss of life and/or property. For applications requiring high reliability and/or presenting an extreme operating environment, written consent and authorization from ABRACON is required. Please contact ABRACON for more information.
- vi) All specifications and Marking will be subject to change without notice.

13. ABRACON LLC – TERMS & CONDITIONS OF SALE

The following are the terms and conditions under which Abracon LLC (“AB”) agrees to sell, to the entity named on the face hereof (“Buyer”), the products specified on the face hereof (the “Products”). Notwithstanding Buyer’s desire to use standardized RFQs, purchase order forms, order forms, acknowledgment forms and other documents which may contain terms in addition to or at variance with these terms, it is expressly understood and agreed that other forms shall neither add to, nor vary, these terms whether or not these terms are referenced therein. Buyer may assent to these terms by written acknowledgment, implication and/or by acceptance or payment of goods ordered any of which will constitute assent.

1. **Prices:** Prices shown on the face hereof are in US dollars, with delivery terms specified herein and are exclusive of any other charges including, without limitation, fees for export, special packaging, freight, insurance and similar charges. AB reserves the right to increase the price of Products by written notice to Buyer at least thirty (30) days prior to the original date of shipment. When quantity price discounts are quoted by AB, the discounts are computed separately for each type of product to be sold and are based upon the quantity of each type and each size ordered at any one time. If any discounted order is reduced by Buyer with AB’s consent, the prices shall be adjusted to the higher prices, if applicable, for the remaining order.
2. **Taxes:** Unless otherwise specified in the quotation, the prices do not include any taxes, import or export duties, tariffs, customs charges or any such other levies. Buyer agrees to reimburse AB the amount of any federal, state, county, municipal, or other taxes, duties, tariffs, or custom charges AB is required to pay. If Buyer is exempt from any such charges, Buyer must provide AB with appropriate documentation.
3. **Payment Terms:** For each shipment, AB will invoice Buyer for the price of the Products plus all applicable taxes, packaging, transportation, insurance and other charges. Unless otherwise stated in a separate agreement or in AB’s quotation, payments are due within thirty (30) days from the date of invoice, subject to AB’s approval of Buyer’s credit application. All invoicing disputes must be submitted in writing to AB within ten (10) days of the receipt of the invoice accompanied by a reasonably detailed explanation of the dispute. Payment of the undisputed amounts shall be made timely. AB reserves the right to require payment in advance or C.O.D. and otherwise modified credit terms. When partial shipments are made, payments for such shipments shall become due in accordance with the above terms upon submission of invoices. If, at the request of Buyer, shipment is postponed for more than thirty (30) days, payment will become due thirty days after notice to Buyer that Products are ready for shipment. Any unpaid due amounts will be subject to interest at one decimal five percent (1.5%) per month, or, if less, the maximum rate allowed by law.

4. **Delivery and Shipment:** Shipment dates are estimates only. Failure to deliver by a specified date shall neither entitle Buyer to any compensation nor impose any liability on AB. AB reserves the right to ship and bill ten percent more or less than the exact quantity specified on the face hereof. All shipments will be made Ex Works as per Incoterms 2000 from AB's place of shipment. In the absence of specific instructions, AB will select the carrier. Claims against AB for shortages must be made in writing within ten (10) days after the arrival of the shipment. AB is not required to notify Buyer of the shipment. Buyer shall pay all freight charges, insurance and other shipping expenses. Freight charges, insurance and other shipping expenses itemized in advance of actual shipment, if any, are estimates only that are calculated on the basis of standard tariffs and may not reflect actual costs. Buyer must pay actual costs.
5. **Purchase Order Changes and Cancellations:** Purchase orders for standard AB Products may not be canceled within sixty (60) days of the original shipping date. Purchase orders for non-standard AB Products are non-cancelable and non-returnable. All schedule changes must be requested at least thirty (30) days prior to original shipping date. Maximum schedule change "push-out" shall be no more than thirty (30) days from original shipping date. AB may terminate or cancel this order, in whole or in part, at any time prior to the completion of performance by written notice to Buyer without incurring any liability to Buyer for breach of contract or otherwise. AB reserves the right to allocate Products in its sole discretion among Buyer and other potential buyers, or defer or delay the shipment of any Product, which is in short supply due to any reason.
6. **Title and Risk of Loss:** AB's responsibility for any loss or damage ends, and title passes, when Products are delivered Ex Works as per Incoterms 2000 at AB's designated shipping location to carrier, to Buyer or to Buyer's agent, whichever occurs first.
7. **Packing:** Packaging shall be AB's standard shipping materials or as specified on the face hereof. Any cost of non-standard packaging and handling requested by Buyer shall be abided by AB provided Buyer gives reasonable prior notice and agrees in writing to pay additional costs.
8. **Security Interest:** Buyer hereby grants AB a purchase money security interest in the Products sold and in the proceeds of resale of such Products until such time as Buyer has paid all charges. AB retains all right and remedies available to AB under the Uniform Commercial Code.
9. **Specifications:** Specifications for each Product are the specifications specified in the published datasheets of such Product, as of the date of AB's quotation (the "Specifications"). Except as otherwise agreed, AB reserves the right to modify the Specifications at any time without adversely affecting the functionality.
10. **Acceptance:** Unless Buyer notifies AB in writing within ten (10) days from the date of receipt of Products that the Products fail to conform to the Specifications, the Products will be deemed accepted by Buyer. No such claim of non-conformity shall be valid if (i) the Products have been altered, modified or damaged by Buyer, (ii) the rejection notice fails to explain the non-conformance in reasonable detail and is not accompanied by a test report evidencing the non-conformity, or (iii) rejected Products are not returned to AB within thirty (30) days of rejection; provided, that no Product returns may be made without a return material authorization issued by AB.
11. **Limited Warranties and Disclaimers:** AB warrants to Buyer that each Product, for a period of twelve (12) months from shipment date thereof, will conform to the Specifications and be free from defects in materials and workmanship. AB's sole liability and Buyer's exclusive remedy for Products that fail to conform to this limited warranty ("Defective Products") is limited to repair or replacement of such Defective Products, or issue a credit or rebate of no more than the purchase price of such Defective Products, at AB's sole option and election. This warranty shall not apply: (i) if Products have been damaged or submitted to abnormal conditions (mechanical, electrical, or thermal) during transit, storage, installation, or use; or (ii) if Products are subject to Improper Use (as defined below); or (iii) if the non-conformance of Products results from misuse, neglect, improper testing, storage, installation, unauthorized repair, alteration, or excess usage at or beyond the maximum values (temperature limit, maximum voltage, and other Specification limits) defined by AB; (iv) to any other default not attributable to AB; or (v) removal, alteration, or tampering of the original AB product labeling. This warranty does not extend to Products or components purchased from entities other than AB or AB's authorized distributors or to third-party software or documentation that may be supplied with any Product. In the event no defect or breach of warranty is discovered by AB upon receipt of any returned Product, such Product will be returned to Buyer at Buyer's expense and Buyer will reimburse AB for the transportation charges, labor, and associated charges incurred in testing the allegedly Defective Product. The above warranty is for Buyer's benefit only, and is non-transferable. OTHER THAN THE LIMITED WARRANTY SET FORTH ABOVE, AB MAKES NO WARRANTIES, EXPRESS, STATUTORY, IMPLIED, OR OTHERWISE AND SPECIFICALLY DISCLAIMS THE IMPLIED WARRANTIES OF MERCHANTABILITY, FITNESS FOR A PARTICULAR PURPOSE AND NON-

INFRINGEMENT, TO THE MAXIMUM EXTENT PERMITTED BY LAW. WITHOUT LIMITING THE GENERALITY OF THE FOREGOING DISCLAIMERS, AB INCORPORATES BY REFERENCE ANY PRODUCT-SPECIFIC WARRANTY DISCLAIMERS SET FORTH IN THE PUBLISHED PRODUCT DATASHEETS.

12. **Limitation of Liability:** AB SHALL HAVE NO LIABILITY FOR LOSS ARISING FROM ANY CLAIM MADE AGAINST BUYER, OR FOR SPECIAL, INDIRECT, RELIANCE, INCIDENTAL, CONSEQUENTIAL, OR PUNITIVE DAMAGES INCLUDING, WITHOUT LIMITATION, LOSS OF USE, PROFITS, REVENUES, OR COST OF PROCUREMENT OF SUBSTITUTE GOODS BASED ON ANY BREACH OR DEFAULT OF AB, HOWEVER CAUSED, AND UNDER ANY THEORY OF LIABILITY. BUYER'S SOLE REMEDY AND AB'S SOLE AND TOTAL LIABILITY FOR ANY CAUSE OF ACTION, WHETHER IN CONTRACT (INCLUDING BREACH OF WARRANTY) OR TORT (INCLUDING NEGLIGENCE OR MISREPRESENTATION) OR UNDER STATUTE OR OTHERWISE SHALL BE LIMITED TO AND SHALL NOT EXCEED THE AGGREGATE AMOUNTS PAID BY BUYER TO AB FOR PRODUCTS WHICH GIVE RISE TO CLAIMS. BUYER SHALL ALWAYS INFORM AB OF ANY BREACH AND AFFORD AB REASONABLE OPPORTUNITY TO CORRECT ANY BREACH. THE FOREGOING LIMITATIONS SHALL APPLY REGARDLESS OF WHETHER AB HAS BEEN ADVISED OF THE POSSIBILITY OF SUCH DAMAGES AND NOTWITHSTANDING THE FAILURE OF ESSENTIAL PURPOSE OF ANY LIMITED REMEDY.
13. **Improper Use:** Buyer agrees and covenants that, without AB's prior written approval, Products will not be used in life support systems, human implantation, nuclear facilities or systems or any other application where Product failure could lead to loss of life or catastrophic property damage (each such use being an "Improper Use"). Buyer will indemnify and hold AB harmless from any loss, cost, or damage resulting from Improper Use of the Products.
14. **Miscellaneous:** In the event of any insolvency or inability to pay debts as they become due by Buyer, or voluntary or involuntary bankruptcy proceeding by or against Buyer, or appointment of a receiver or assignee for the benefit of creditors of Buyer, AB may elect to cancel any unfulfilled obligations. No Products or underlying information or technology may be exported or re-exported, directly or indirectly, contrary to US law or US Government export controls. AB will be excused from any obligation to the extent performance thereof is caused by, or arises in connection with, acts of God, fire, flood, riots, material shortages, strikes, governmental acts, disasters, earthquakes, inability to obtain labor or materials through its regular sources, delay in delivery by AB's supplies or any other reason beyond the reasonable control of AB. In the event any one or more of the provisions contained herein shall for any reason be held to be invalid, illegal, or unenforceable in any respect, such invalidity, illegality, or unenforceability shall not affect any other provision hereof and these terms shall be construed as if such invalid, illegal, or unenforceable provision had never been contained herein. A waiver of a breach or default under these terms shall not be a waiver of any subsequent default. Failure of AB to enforce compliance with any of these terms shall not constitute a waiver of such terms. These terms are governed by the laws of the State of California without reference to conflict of law principles. The federal and state courts located within the State of California will have exclusive jurisdiction to adjudicate any dispute arising out of these terms.



Стандарт Электрон Связь

Мы молодая и активно развивающаяся компания в области поставок электронных компонентов. Мы поставляем электронные компоненты отечественного и импортного производства напрямую от производителей и с крупнейших складов мира.

Благодаря сотрудничеству с мировыми поставщиками мы осуществляем комплексные и плановые поставки широчайшего спектра электронных компонентов.

Собственная эффективная логистика и склад в обеспечивает надежную поставку продукции в точно указанные сроки по всей России.

Мы осуществляем техническую поддержку нашим клиентам и предпродажную проверку качества продукции. На все поставляемые продукты мы предоставляем гарантию .

Осуществляем поставки продукции под контролем ВП МО РФ на предприятия военно-промышленного комплекса России , а также работаем в рамках 275 ФЗ с открытием отдельных счетов в уполномоченном банке. Система менеджмента качества компании соответствует требованиям ГОСТ ISO 9001.

Минимальные сроки поставки, гибкие цены, неограниченный ассортимент и индивидуальный подход к клиентам являются основой для выстраивания долгосрочного и эффективного сотрудничества с предприятиями радиоэлектронной промышленности, предприятиями ВПК и научно-исследовательскими институтами России.

С нами вы становитесь еще успешнее!

Наши контакты:

Телефон: +7 812 627 14 35

Электронная почта: sales@st-electron.ru

Адрес: 198099, Санкт-Петербург,
Промышленная ул, дом № 19, литера Н,
помещение 100-Н Офис 331