

Circuits from the Lab™
Reference Circuits

Circuits from the Lab™ reference circuits are engineered and tested for quick and easy system integration to help solve today's analog, mixed-signal, and RF design challenges. For more information and/or support, visit www.analog.com/CN0229.

Devices Connected/Referenced

AD5750-2	Industrial Current/Voltage Output Driver with Programmable Ranges
AD5686R	Quad, 16-Bit nanoDAC+ with 2.5 V, 2 ppm/°C On-Chip Reference
ADuM5400	Quad-Channel Isolator with Integrated DC-to-DC Converter
ADuM1301	Triple-Channel Digital Isolator

4-Channel, Flexible, Configurable, Voltage, and Current Output Circuit for I/O Card and PLC Applications

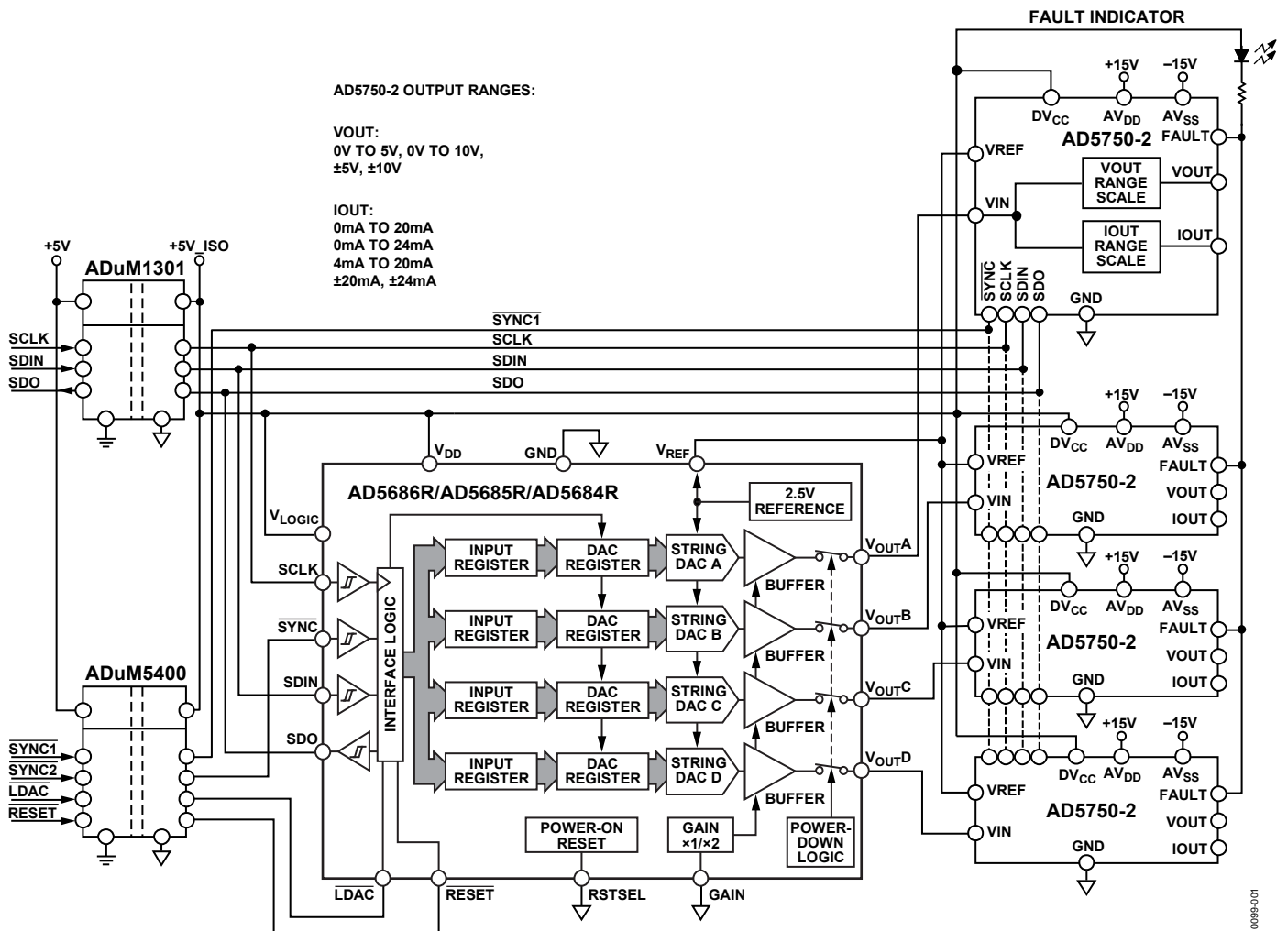

Figure 1. Simplified Schematic of the Analog Output Circuit (All Connections and Protection Circuits Not Shown)

Rev. 0

Circuits from the Lab™ circuits from Analog Devices have been designed and built by Analog Devices engineers. Standard engineering practices have been employed in the design and construction of each circuit, and their function and performance have been tested and verified in a lab environment at room temperature. However, you are solely responsible for testing the circuit and determining its suitability and applicability for your use and application. Accordingly, in no event shall Analog Devices be liable for direct, indirect, special, incidental, consequential or punitive damages due to any cause whatsoever connected to the use of any Circuits from the Lab circuits. (Continued on last page)

EVALUATION AND DESIGN SUPPORT

Circuit Evaluation Boards

[CN-0229 Circuit Evaluation Board \(EVAL-CN0229-SDPZ\)](#)
[System Demonstration Platform \(EVAL-SDP-CB1Z\)](#)

Design and Integration Files

[Schematics, Layout Files, Bill of Materials](#)

CIRCUIT FUNCTION AND BENEFITS

The circuit shown in Figure 1 is a multichannel, flexible, analog output solution with only two analog components and meets most requirements for multichannel I/O cards, programmable logic controllers (PLCs), and distributed control systems (DCSs) applications. The [AD5686R](#) quad, 16-bit nanoDAC+ with rail-to-rail buffered outputs combined with four of the [AD5750-2](#) industrial current/voltage output drivers provide all the typical output current and voltage ranges with 16-bit resolution, no missing codes, 0.05% linearity, and less than 0.1% output error.

An ultralow drift (2 ppm/°C typical), 2.5 V voltage reference with high drive capability (up to ±5 mA) is integrated in the [AD5686R](#) and provides the reference voltage for both the [AD5686R](#) and the [AD5750-2](#). This guarantees low noise, high accuracy, and low temperature drift for the circuit.

The [ADuM1301](#) and [ADuM5400](#) provide 2500 V rms isolation both on power, and all the necessary signals between the analog signal chain and the host controller.

For multichannel I/O card applications that need more than 4 channels, several [AD5686R](#)s can be connected in a daisy chain, and no additional external digital I/O circuits are required. This minimizes the cost, especially for high channel count isolated applications.

The circuit also contains key features for industrial applications, such as on-chip output fault detection, packet error checking (PEC) by the CRC, flexible power-up options, and ESD protection (4 kV for the [AD5686R](#), human body model and 3 kV for the [AD5750-2](#), human body model), making it an ideal choice for robust industrial control systems. No external precision resistors or calibration routines are needed to maintain consistent performance in mass production, thereby making it ideal for PLC or DCS modules.

CIRCUIT DESCRIPTION

The [AD5750/AD5750-1/AD5750-2](#) are single-channel, low cost, precision voltage/current output drivers developed to meet the requirements of industrial process control applications. The output voltage range can be programmed for the standard output ranges for PLC and DCS applications: 0 V to 5 V, 0 V to 10 V, -5 V to +5 V, and -10 V to +10 V. A 20% overrange setting is also provided for the standard ranges, giving the following options: 0 V to +6 V, 0 V to +12 V, -6 V to +6 V, and -12 V to +12 V.

The current output, which is provided on a separate pin, can be programmed for the ranges of +4 mA to +20 mA, 0 mA to +20 mA, -20 mA to +20 mA, 0 mA to +24 mA, and -24 mA to +24 mA. The unipolar ranges have a 2% overrange setting.

Because the [AD5750/AD5750-1/AD5750-2](#) current outputs can either source or sink current, they can interface to a wide variety of sensors or actuators. The voltage and current output pins can be connected together to configure the system as a single-channel output if desired.

Generally, the current output circuit needs at least one precision resistor for current sensing. The current accuracy and temperature drift characteristic of the circuit depends partly on the resistor as well as the reference. The [AD5750/AD5750-1/AD5750-2](#) integrates the high precision, low drift resistor and still allows the use of an external resistor, if desired. As a method of improving the stability of the output current over temperature, an external low drift resistor can be connected to the REXT1 and REXT2 pins of the [AD5750/AD5750-1/AD5750-2](#), instead of the internal resistor. The external resistor is selected via the input shift register. If the external resistor option is not used, leave the REXT1 and REXT2 pins floating.

The [AD5686R](#) is a quad 16-bit nanoDAC+ with rail-to-rail voltage-buffered outputs integrated with an on-chip 2 ppm/°C typical (5 ppm/°C maximum), 2.5 V reference. The on-chip reference can drive the reference input of all four [AD5750-2](#)s, has a low output impedance of 0.05 Ω, and can source and sink up to 5 mA. The [AD5686R](#) incorporates a power-on reset circuit to ensure that the DAC output powers up to 0 V and remains there until a valid write command takes place.

The interface between the [AD5686R](#) DAC and the [AD5750-2](#) driver is simple and requires no external voltage reference or precision resistors. The output voltage range of the [AD5686R](#) is 0 V to 2.5 V, which matches the input range of the [AD5750-2](#). In addition, the reference output voltage of the [AD5686R](#) is 2.5 V, which precisely matches the reference input requirement of the [AD5750-2](#).

The [ADuM1301](#) is a triple-channel digital isolator. The [ADuM5400](#) is a quad-channel digital isolator with an integrated, isolated, dc-to-dc converter. They are both based on *iCoupler*® technology and are used to provide isolation between the signal chain and the system microcontroller, with an isolation rating of 2.5 kV rms. The [ADuM5400](#) provides an isolated 5 V power supply for the 5 V circuits in the secondary side.

Devices for PLC and DCS applications generally need ESD protection and overvoltage protection much higher than the formal recommend specifications. The [AD5686R](#) and the [AD5750-2](#) have internal ESD protection diodes to each pin that can prevent damage from a 4 kV ([AD5686R](#)) and 3 kV ([AD5750-2](#)) transient (human body model). However, the industrial control environment can subject I/O circuits to much higher transients.

Use the external 54 V, 600 W transient voltage suppressors (TVSs) as the first stage of enhanced ESD protection. Place power Schottky diodes in series with a 1 kΩ, 0.5 W resistor on the VSENSE+ and VSENSE– pins of the AD5750-2, and place a 50 mA, 30 V polyswitch on the VOUT and IOUT pins. These protective circuits are included in the EVAL-CN0229-SDPZ circuit board to provide 50 V overvoltage protection and 50 mA overcurrent protection. The optional external protection circuits are not shown in the simplified schematic of Figure 1 but can be found in the detailed schematic (EVAL-CN0229-SDPZ-PADSSchematic pdf file) in the CN0229 Design Support package: <http://www.analog.com/CN0229-DesignSupport>.

Construct the circuit on a multilayer printed circuit board (PCB) board with a large area ground plane. Use proper layout, grounding, and decoupling techniques to achieve optimum system performance and low EMI (see Tutorial MT-031, *Grounding Data Converters and Solving the Mystery of "AGND" and "DGND,"* and Tutorial MT-101, *Decoupling Techniques*).

Measurements

Integral nonlinearity (INL), differential nonlinearity (DNL), and output error are the most important specifications for PLC, DCS, and other process control systems. The AD5750-2 has highly flexible and configurable output ranges that can be tailored to meet the needs of the application. Measurements of INL, DNL, and output error for the circuit are shown in Figure 2, Figure 3, and Figure 4, respectively. This data was taken at 25°C in the voltage output mode. The AD5750-2 range was set for 0 V to 5 V. The test results for all the other ranges are listed in Table 1.

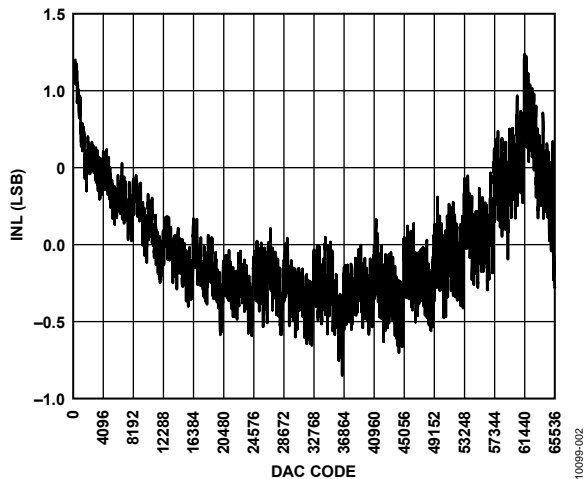

Figure 2. INL for 0 V to 5 V Output Range

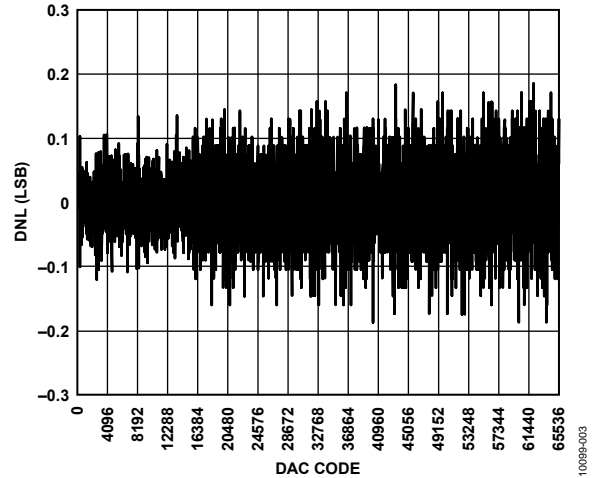

Figure 3. DNL for 0 V to 5 V Output Range

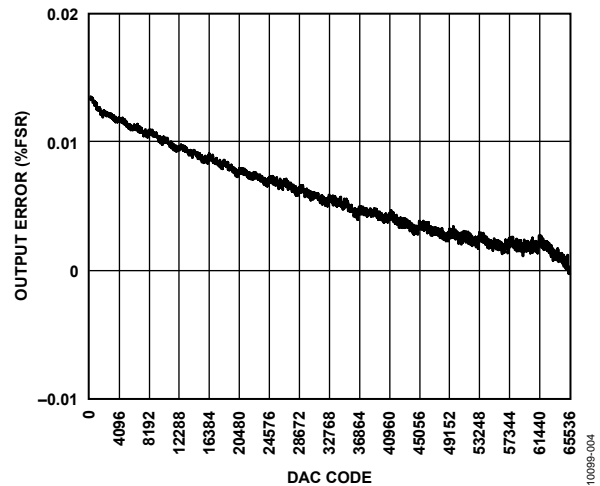

Figure 4. Output Error for 0 V to 5 V Output Range

Table 1. Test Results for All Output Ranges

Range	Current Sense Resistor	INL (LSB)	Linearity (%FSR)	Output Error (%FSR)
0 V to +5 V	Don't care	1.3	0.002	0.01
0 V to +10 V	Don't care	1.1	0.002	0.02
-5 V to +5 V	Don't care	1.4	0.002	0.02
-10 V to +10 V	Don't care	1.2	0.002	0.02
0 V to +6 V	Don't care	1.9	0.003	0.02
0 V to +12 V	Don't care	1.4	0.002	0.05
-6 V to +6 V	Don't care	1.3	0.002	0.03
-12 V to +12 V	Don't care	1.7	0.003	0.05
-2.5 V to +2.5 V	Don't care	1.3	0.002	0.03
+4 mA to +20 mA	Internal	5.3	0.008	0.07
0 mA to +20 mA	Internal	4.2	0.006	0.06
0 mA to +24 mA	Internal	2.9	0.004	0.05
-20 mA to +20 mA	Internal	5.4	0.008	0.02
-24 mA to +24 mA	Internal	3.9	0.006	0.02
+4 mA to +20mA	External	2.0	0.003	0.04
0 mA to +20mA	External	1.7	0.003	0.04
0 mA to +24mA	External	1.6	0.002	0.04
-20 mA to +20 mA	External	3.7	0.006	0.03
-24 mA to +24 mA	External	4.4	0.007	0.03
+3.92 mA to +20.4 mA	Internal	1.7	0.014	0.11
0 mA to +20.4 mA	Internal	2.9	0.006	1.86
0 mA to +24.5 mA	Internal	2.5	0.005	0.30

The test results shown in Table 1 were made at 25°C for the first channel of the [EVAL-CN0229-SDPZ](#) board powered by an Agilent E3631A dc supply and measured with the Agilent 34401A digital multimeter.

Note that the output ranges 3.92 mA to 20.4 mA, 0 mA to 20.4 mA, and 0 mA to 24.5 mA are all designed to be trimmed by the customer to precisely match the 4 mA to 20 mA, 0 mA to 20 mA, and 0 mA to 24 mA ranges. The 1.86% FSR output error measurement in the 0 mA to 20.4 mA range includes the gain error, which is easily removed by customer calibration.

There is a lower dead band about 10 mV referenced to GND. All the linearity test results were calculated using a reduced code range of 256 to 65,535. For 3.92 mA to 20.4 mA, 0 mA to 20.4 mA, and 0 mA to 24.5 mA, the lower dead band is larger than other standard ranges, and the measured code range is from 1000 to 65,535.

COMMON VARIATIONS

The [AD5685R](#) (14 bits) and the [AD5684R](#) (12 bits) are pin-compatible with the [AD5686R](#) for applications not requiring 16-bit resolution.

For applications that require channel-to-channel isolation, single DACs, such as the [AD5660](#) (16 bits), the [AD5640](#) (14 bits), and the [AD5620](#) (12 bits), are good choices.

For single-channel applications, see the [CN-0202](#), [CN-0203](#), and [CN-0204](#) circuit notes for more details.

For multichannel applications, the [AD5623R](#) (12-bits), [AD5643R](#) (14-bits), and [AD5663R](#) (16-bits) are dual nanoDACs, and the [AD5624R](#) (12-bits), [AD5644R](#) (14-bits), and [AD5664R](#) (16-bits) are quad nanoDACs. The [AD5628/AD5648/AD5668](#) are octal 12-/14-/16-bit SPI voltage output denseDACs with 5 ppm/°C on-chip references.

The [AD5750](#) and [AD5750-1](#) drivers are pin-compatible with the [AD5750-2](#). The [AD5750](#) can accept 0 V to 4.096 V input with a 4.096 V reference. The [AD5750-1](#) can accept a 0 V to 2.5 V input with a 1.25 V reference. The [AD5751](#) is a unipolar analog output driver and can supply a 40 V output using a 50 V AVDD supply.

CIRCUIT EVALUATION AND TEST

Equipment Needed (Equivalents Can Be Substituted)

- System Demonstration Platform ([EVAL-SDP-CB1Z](#))
- CN-0229 Circuit Evaluation Board ([EVAL-CN0229-SDPZ](#))
- CN-0229 Evaluation Software
- Agilent 34401A 6.5 Digital Multimeter
- Agilent E3631A 0 V to ~6 V/5 A ±25 V/1 A Triple Output DC Power Supply
- PC (Windows® 2000 or Windows XP) with USB interface
- National Instruments GPIB to USB-B interface and cable

Getting Started

Load the evaluation software by placing the CN-0229 evaluation software CD into the CD drive of the PC. Using **My Computer**, locate the drive that contains the evaluation software CD and open the **Readme** file. Follow the instructions contained in the **Readme** file for installing and using the evaluation software.

Functional Block Diagram

Figure 5 shows a functional block diagram of the test setup. The **EVAL-CN0229-PADSSchematic** pdf file contains the detailed circuit schematics for the CN-0229 evaluation board. This file is contained in the CN-0229 Design Support Package:

<http://www.analog.com/CN0229-DesignSupport>.

Setup

Connect the 120-pin connector on the EVAL-CN0229-SDPZ circuit board to the CON A connector or the CON B connector on the **EVAL-SDP-CB1Z** (SDP) board. Use nylon hardware to firmly secure the two boards, using the holes provided at the ends of the 120-pin connectors. After successfully setting the dc output supply to +15 V, -15 V, and +6 V output, turn the power supply off.

With power to the supply off, connect a +15 V power supply to +15 V pin of CN1, a -15 V power supply to the -15 V pin of CN1, and GND to the GND pin of CN1. Connect +6 V to CN2 the same way. Turn on the power supply and then connect the USB cable with the SDP board to the USB port on the PC. Note: Do not connect the USB cable to the Mini-USB connector on the SDP board before turning on the dc power supply for the **EVAL-CN0229-SDPZ**.

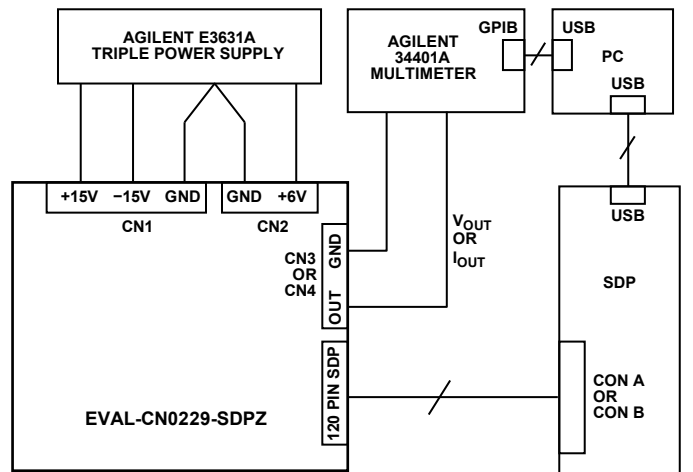

Figure 5. Test Setup Functional Block Diagram

Table 2. Jumper Settings for EVAL-CN0229-SDPZ (Bolded Values Are Default Settings)

Jumper ¹	Descriptions	Setting	Function
JP1_[CH]	VSENSE+ setting	Shorting	Shorts VSENSE+ with VOUT internally for Channel [CH].
		Opening	VSENSE+ has no connection with VOUT internally for Channel [CH].
JP2_[CH]	VSENSE- setting	Shorting	Shorts VSENSE- with GND internally for Channel [CH].
		Opening	VSENSE- has no connection with GND internally for Channel [CH].
JP3_[CH]	Shorts the VOUT and IOUT pins	Shorting	Shorts VOUT and IOUT together for Channel [CH].
		Opening	VOUT and IOUT have no connection internally for Channel [CH].
JP4_[CH]	Sets the external compensation capacitor	Shorting	Adds an 1 nF compensation capacitor for Channel [CH].
		Opening	Removes an 1 nF compensation capacitor for Channel [CH].

¹ Note: [CH] = 1, 2, 3, or 4.

Test

After setting up the test equipment, connect the VOUT pin of CN3 or the IOOUT pin of CN4 to the input of the Agilent 34401A. Ensure that the cable connection on the front panel of Agilent 34401A is correct, depending on the different input signal type (current or voltage). Testing the INL, DNL, and output error takes a considerable amount of time because all the AD5686R 16-bit DAC levels must be set and measured by the Agilent 34401A.

The software provided on the CD allows the DAC codes to be set by the PC. An automatic test program is necessary to step through the codes and analyze the data. This is not provided on the CD but must be implemented by the customer to correspond to the requirements of the particular multimeter used in the test setup.

In the test configuration shown in Figure 5, the GPIB output of the Agilent 34401A multimeter interfaces to a second USB port on the PC using the National Instruments GPIB to USB-B interface and cable. This allows the multimeter readings corresponding to each code to be loaded into an Excel spreadsheet in the PC. The data is then be analyzed for INL, DNL, and output error using industry-standard definitions.

For more details on the definitions and how to calculate the INL, DNL, and output error from the measured data, see the Terminology section of the AD5686R data sheet and the *Data Conversion Handbook*, "Testing Data Converters," Chapter 5, Analog Devices.

LEARN MORE

CN-0229 Design Support Package:

<http://www.analog.com/CN0229-DesignSupport>

Slattery, Colm, Derrick Hartmann, and Li Ke, "PLC Evaluation Board Simplifies Design of Industrial Process Control Systems." *Analog Dialogue* (April 2009).

CN-0202 Circuit Note, *Flexible High Accuracy, Low Drift, PLC/DCS Analog Output Module*.

CN-0203 Circuit Note, *Flexible PLC/DCS Analog Output Module Using Only Two Analog Components*.

CN-0204 Circuit Note, *Flexible, High Voltage, High Accuracy, Low Drift PLC/DCS Analog Output Module*.

CN-0063 Circuit Note, *16-Bit Fully Isolated Voltage Output Module Using the AD5662 DAC, ADuM1401 Digital Isolator, and External Amplifiers*, Analog Devices.

CN-0064 Circuit Note, *16-Bit Fully Isolated 4 mA to 20 mA Output Module Using the AD5662 DAC, ADuM1401 Digital Isolator, and External Amplifiers*, Analog Devices.

CN-0065 Circuit Note, *16-Bit Fully Isolated Output Module Using the AD5422 Single Chip Voltage and Current Output DAC and the ADuM1401 Digital Isolator*, Analog Devices.

CN-0066 Circuit Note, *Fully Isolated Input Module Based on the AD7793 24-Bit Σ - Δ ADC and the ADuM5401 Digital Isolator*, Analog Devices.

CN-0067 Circuit Note, *Fully Isolated Input Module Based on the AD7793 24-Bit Σ - Δ ADC, the ADuM5401 Digital Isolator, and a High Performance In-Amp*, Analog Devices.

CN-0097 Circuit Note, *Simplified 12-Bit Voltage and 4 mA-to-20 mA Output Solution Using the AD5412*, Analog Devices.

CN-0209 Circuit Note, *Fully Programmable Universal Analog Front End for Process Control Applications*, Analog Devices.

AN-0971 *Recommendations for Control of Radiated Emissions with isoPower Devices* by Mark Cantrell

MT-031 Tutorial, *Grounding Data Converters and Solving the Mystery of "AGND" and "DGND"*, Analog Devices.

MT-101 Tutorial, *Decoupling Techniques*, Analog Devices.

Walt Kester, *Practical Design Techniques for Sensor Signal Conditioning*, Analog Devices, 1999, ISBN 0-916550-20-6

Walt Kester, *Data Conversion Handbook*, Chapter 5, Analog Devices.

Data Sheets and Evaluation Boards

CN-0229 Circuit Evaluation Board (EVAL-CN0229-SDPZ)

System Demonstration Platform (EVAL-SDP-CB1Z)

AD5750-2 Data Sheet and Evaluation Board

AD5686R Data Sheet and Evaluation Board

ADuM5400 Data Sheet and Evaluation Board

ADuM1301 Data Sheet and Evaluation Board

REVISION HISTORY

4/12—Rev. 0: Initial Version

(Continued from first page) Circuits from the Lab circuits are intended only for use with Analog Devices products and are the intellectual property of Analog Devices or its licensors. While you may use the Circuits from the Lab circuits in the design of your product, no other license is granted by implication or otherwise under any patents or other intellectual property by application or use of the Circuits from the Lab circuits. Information furnished by Analog Devices is believed to be accurate and reliable. However, Circuits from the Lab circuits are supplied "as is" and without warranties of any kind, express, implied, or statutory including, but not limited to, any implied warranty of merchantability, noninfringement or fitness for a particular purpose and no responsibility is assumed by Analog Devices for their use, nor for any infringements of patents or other rights of third parties that may result from their use. Analog Devices reserves the right to change any Circuits from the Lab circuits at any time without notice but is under no obligation to do so.



Стандарт Электрон Связь

Мы молодая и активно развивающаяся компания в области поставок электронных компонентов. Мы поставляем электронные компоненты отечественного и импортного производства напрямую от производителей и с крупнейших складов мира.

Благодаря сотрудничеству с мировыми поставщиками мы осуществляем комплексные и плановые поставки широчайшего спектра электронных компонентов.

Собственная эффективная логистика и склад в обеспечивает надежную поставку продукции в точно указанные сроки по всей России.

Мы осуществляем техническую поддержку нашим клиентам и предпродажную проверку качества продукции. На все поставляемые продукты мы предоставляем гарантию .

Осуществляем поставки продукции под контролем ВП МО РФ на предприятия военно-промышленного комплекса России , а также работаем в рамках 275 ФЗ с открытием отдельных счетов в уполномоченном банке. Система менеджмента качества компании соответствует требованиям ГОСТ ISO 9001.

Минимальные сроки поставки, гибкие цены, неограниченный ассортимент и индивидуальный подход к клиентам являются основой для выстраивания долгосрочного и эффективного сотрудничества с предприятиями радиоэлектронной промышленности, предприятиями ВПК и научно-исследовательскими институтами России.

С нами вы становитесь еще успешнее!

Наши контакты:

Телефон: +7 812 627 14 35

Электронная почта: sales@st-electron.ru

Адрес: 198099, Санкт-Петербург,
Промышленная ул, дом № 19, литера Н,
помещение 100-Н Офис 331