



MAX4952A Evaluation Kit

Evaluates: MAX4952A

General Description

The MAX4952A evaluation kit (EV kit) provides a proven design to evaluate the MAX4952A dual-channel buffer. The EV kit contains four sections: an application circuit, characterization circuit, and two calibration traces.

The application circuit (Figure 1a) is designed to demonstrate the MAX4952A IC's use in re-driving Serial-Attached SCSI (SAS) and Serial ATA (SATA) signals. This section of the EV kit operates from an external +5V supply that is regulated by an on-board LDO to +3.3V, which powers the MAX4952A (U1) device. All traces in the application circuit are 100Ω differential controlled-impedance traces.

The characterization circuit (Figure 1b) is provided for eye diagram evaluation using SMA connectors and 50Ω single-ended controlled-impedance traces. This section is powered by an external +3.3V supply.

Features

- ◆ Application Circuit with SAS and SATA Input/Output
- ◆ Eye Diagram Test Circuit with SMA Inputs/Outputs
- ◆ Calibration Traces (50Ω Single-Ended Load Trace and 50Ω Single-Ended Through Trace)
- ◆ Lead(Pb)-Free and RoHS Compliant
- ◆ Proven PCB Layout
- ◆ Fully Assembled and Tested

Ordering Information

PART	TYPE
MAX4952AEVKIT+	EV Kit

+Denotes lead(Pb)-free and RoHS compliant.

Component List

DESIGNATION	QTY	DESCRIPTION
C1–C12, C19–C26, C32–C35	24	0.01μF ±10%, 25V X7R ceramic capacitors (0402) Murata GRM155R71E103KA TDK C1005X7R1E103K
C13–C16, C27–C30	8	2.2μF ±10%, 10V X7R ceramic capacitors (0603) Murata GRM188R71A225K
C17, C31	2	1μF ±10%, 16V X7R ceramic capacitors (0603) Murata GRM188R71C105K TDK C1608X7R1C105K
C18	1	0.1μF ±10%, 16V X7R ceramic capacitor (0402) Murata GRM155R71C104K TDK C1005X7R1C104K
D1	1	Green LED (0603)
H1	1	Disk-drive power connector
J1, J2	2	7-position SAS vertical connectors

DESIGNATION	QTY	DESCRIPTION
JU1–JU10	10	3-pin headers, 0.1in centers
JU11	1	2-pin header, 0.1in centers
P1–P10	10	Edge-mount receptacle SMA connectors
R1	1	200Ω ±5% resistor (0603)
R2, R3	2	49.9Ω ±1% resistors (0603)
U1, U2	2	1.5/3.0/6.0GT/s SAS/SATA re-drivers (28 TQFN-EP*) Maxim MAX4952ACTI+
U3	1	3.3V regulator (6 SOT23) Maxim MAX6329TPUT-T+ (Top Mark: AAIP)
—	11	Shunts
—	1	PCB: MAX4952A EVALUATION KIT+

*EP = Exposed pad.

Component Suppliers

SUPPLIER	PHONE	WEBSITE
Murata Electronics North America, Inc.	770-436-1300	www.murata-northamerica.com
TDK Corp.	847-803-6100	www.component.tdk.com

Note: Indicate that you are using the MAX4952A when contacting these component suppliers.



Maxim Integrated Products 1

For pricing, delivery, and ordering information, please contact Maxim Direct at 1-888-629-4642, or visit Maxim's website at www.maxim-ic.com.

MAX4952A Evaluation Kit

Quick Start (Application Circuit)

Recommended Equipment

- MAX4952A EV kit
- +5V power supply
- Two SAS/SATA cables
- SAS/SATA device (e.g., a hard drive)
- SAS/SATA host (e.g., a PC)

Procedure

The MAX4952A EV kit is fully assembled and tested. Follow the steps below to verify board operation:

- 1) Verify that all jumpers are in their default position, as shown in Table 1.
- 2) If testing in a SATA environment, change the shunt on jumper JU6 to the 1-2 position.
- 3) Connect the first SAS/SATA cable from the PC to the host connector (J1) on the EV kit.
- 4) Connect the second SAS/SATA cable from the device connector (J2) to the SAS/SATA device.
- 5) Verify communication between the host PC and SAS/SATA device.

Detailed Description of Hardware

The MAX4952A evaluation kit (EV kit) evaluates the MAX4952A dual-channel buffer. The MAX4952A is designed to re-drive Serial-Attached SCSI (SAS) or Serial ATA (SATA) signals. The EV kit is divided into four

Table 1. Default Shunt Positions

JUMPER	SHUNT POSITION
JU1–JU4, JU7, JU8, JU10	2-3
JU5, JU9	1-2
JU6	2-3 (SAS)
JU11	Installed

Table 2. Jumper JU11 Function

SHUNT POSITION	VCC PIN (U1)	DESCRIPTION
Installed*	Connected to on-board LDO output	U1 powered by LDO output (+3.3V)
Not installed	Connected to external supply	Powered by +3.3V from an external supply or SAS power connector

*Default position.

sections: application circuit, characterization circuit, and two calibration traces.

The application circuit utilizes 100Ω differential controlled impedance traces and provides two SAS connectors (J1 and J2), allowing for evaluation of the MAX4952A in a SAS environment. The characterization circuit utilizes 50Ω single-ended, controlled-impedance traces and SMA input/output connectors, allowing for eye diagrams, and input/output return-loss measurements.

The lower-half of the EV kit provides two sets of calibration traces (Figure 1c), all of which are matched to the trace lengths in the characterization circuit. These traces provide a reference for determining the performance of only the MAX4952A device when evaluated in the characterization circuit.

Application Circuit (U1)

The application circuit provides the means for evaluating the MAX4952A in a SAS/SATA application. This section of the EV kit provides two SAS/SATA connectors (J1 and J2), one for connection to a SAS/SATA host (e.g., a PC) and the other for connection to a SAS/SATA device (e.g., a hard drive).

Power Supply (VIN)

The application circuit must be powered by +3.3V. There are two ways to get this voltage, either the on-board LDO (U3) or an external +3.3V power supply. When using the on-board voltage regulator, the LDO can be powered by the 4-pin Molex connector (H1) or by a +5V external supply connected to the VIN and GND pads. When using the on-board LDO to supply power, there is a power LED (D1) to indicate the presence of +3.3V at VCC.

The user can also connect directly to a +3.3V supply, which is available on a SAS power connector. The shunt should be removed from jumper JU11 and a wire connected from the SAS power pin to pin-2 (right-most pin) of jumper JU11 (see Table 2).

MAX4952A Evaluation Kit

Mode Control (JU6)

The MAX4952A device can also be used to redrive Serial ATA (SATA) signals. The MODE pin configures the device to operate with SATA or SAS signals. See Table 3 for jumper JU6 functions.

Device Enable (JU5)

The MAX4952A (U1) is enabled/disabled by configuring jumper JU5 (see Table 4). When disabled, the

MAX4952A buffers are disabled and the part is placed in a low-power standby mode.

Input Equalization (JU1, JU3)

The MAX4952A host and device can be evaluated with or without input equalization. Configure JU1 to enable/disable the host input (IN0P, IN0M) equalization and JU3 to enable/disable the device input (IN1P, IN1M) equalization (see Tables 5 and 6).

Table 3. Jumper JU6 Function

SHUNT POSITION	MODE PIN (U1)	DESCRIPTION
1-2	Connected to +3.3V	Signal type: SATA
2-3*	Connected to GND	Signal type: SAS
Not installed	Not connected	

*Default position.

Table 4. Jumper JU5 Function

SHUNT POSITION	EN PIN (U1)	DESCRIPTION
1-2*	Connected to +3.3V	Buffers enabled for normal operation
2-3	Connected to GND	Buffers disabled and device is in low-power standby mode
Not installed	Not connected	

*Default position.

Table 5. Jumper JU1 Function

SHUNT POSITION	EQ0 PIN (U1)	DESCRIPTION
1-2	Connected to +3.3V	Host equalization enabled
2-3*	Connected to GND	Host equalization disabled
Not installed	Not connected	

*Default position.

Table 6. Jumper JU3 Function

SHUNT POSITION	EQ1 PIN (U1)	DESCRIPTION
1-2	Connected to +3.3V	Device equalization enabled
2-3*	Connected to GND	Device equalization disabled
Not installed	Not connected	

*Default position.

MAX4952A Evaluation Kit

Output Preemphasis (JU2, JU4)

The MAX4952A host and device can be evaluated with or without output preemphasis. Configure JU2 to enable/disable the host output preemphasis and JU4 to enable/disable the device output preemphasis (see Tables 7 and 8).

Characterization Circuit (U2)

The characterization circuit is provided as a separate test circuit for eye diagram evaluation of the MAX4952A IC. This circuit provides differential SMA inputs and outputs with 50Ω single-ended, controlled-impedance traces. Channel 1 is not utilized in this section of the EV kit, but provides the same performance as Channel 0.

Power Supply (VCC)

The characterization circuit is powered by an external +3.3V power supply connected between the VCC and GND pads.

Mode Control (JU10)

The MAX4952A device (U2) can also be used to redrive Serial ATA (SATA) signals. The MODE pin configures the device to operate with SATA or SAS signals (see Table 9 for jumper JU10 functions).

Device Enable (JU9)

The MAX4952A (U2) is enabled/disabled by configuring jumper JU9 (see Table 10). When disabled, the MAX4952A buffers are disabled and the part is placed in a low-power standby mode.

Table 7. Jumper JU2 Function

SHUNT POSITION	PE0 PIN (U1)	DESCRIPTION
1-2	Connected to +3.3V	Host preemphasis enabled
2-3*	Connected to GND	Host preemphasis disabled
Not installed	Not connected	

*Default position.

Table 8. Jumper JU4 Function

SHUNT POSITION	PE1 PIN (U1)	DESCRIPTION
1-2	Connected to +3.3V	Device preemphasis enabled
2-3*	Connected to GND	Device preemphasis disabled
Not installed	Not connected	

*Default position.

Table 9. Jumper JU10 Function

SHUNT POSITION	MODE PIN (U2)	DESCRIPTION
1-2	Connected to VCC (+3.3V)	Signal type: SATA
2-3*	Connected to GND	Signal type: SAS
Not installed	Not connected	

*Default position.

Table 10. Jumper JU9 Function

SHUNT POSITION	EN PIN (U2)	DESCRIPTION
1-2*	Connected to VCC (+3.3V)	Buffers enabled for normal operation
2-3	Connected to GND	Buffers disabled and device is in low-power standby mode
Not installed	Not connected	

*Default position.

MAX4952A Evaluation Kit

Input Equalization (JU7)

The MAX4952A channel 0 can be evaluated with or without input equalization. Configure JU7 to enable/disable channel 0 equalization.

Output Preemphasis (JU8)

The MAX4952A channel 0 can be evaluated with or without preemphasis. Configure JU8 to enable/disable channel 0 preemphasis.

Calibration Traces

The bottom-half of the EV kit provides two sets of calibration traces, which can be used for further analysis. The lengths of the calibration traces are matched to the traces going from the SMA connector to MAX4952A (U2) of the characterization circuit. The first calibration trace includes a 50Ω single-ended load termination and the second calibration trace is a through trace.

Table 11. Jumper JU7 Function

SHUNT POSITION	EQ0 PIN (U2)	DESCRIPTION
1-2	Connected to VCC (+3.3V)	Channel 0 equalization enabled
2-3*	Connected to GND	Channel 0 equalization disabled
Not installed	Not connected	

*Default position.

Table 12. Jumper JU8 Function

SHUNT POSITION	PE0 PIN (U2)	DESCRIPTION
1-2	Connected to VCC (+3.3V)	Channel 0 preemphasis enabled
2-3*	Connected to GND	Channel 0 preemphasis disabled
Not installed	Not connected	

*Default position.

MAX4952A Evaluation Kit

Evaluates: MAX4952A

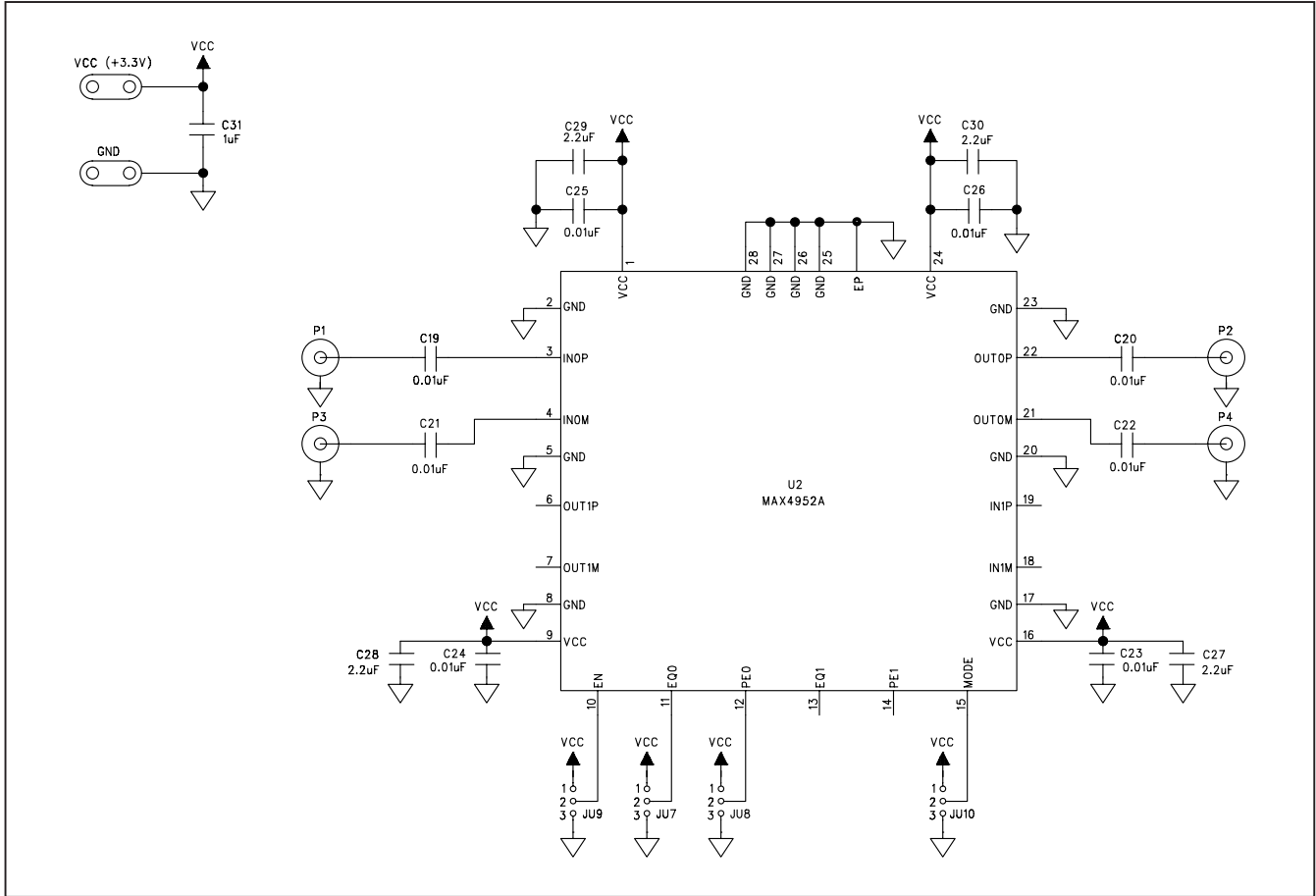

Figure 1b. MAX4952A EV Kit Schematic—Characterization Circuit (Sheet 2 of 3)

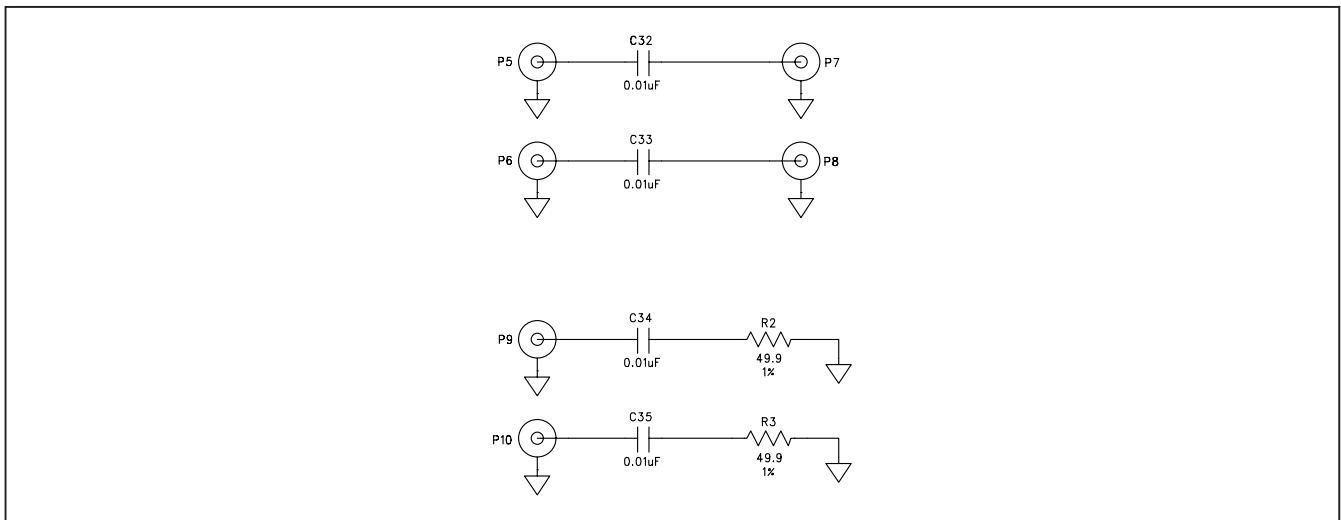

Figure 1c. MAX4952A EV Kit Schematic—Calibration Traces (Sheet 3 of 3)

MAX4952A Evaluation Kit

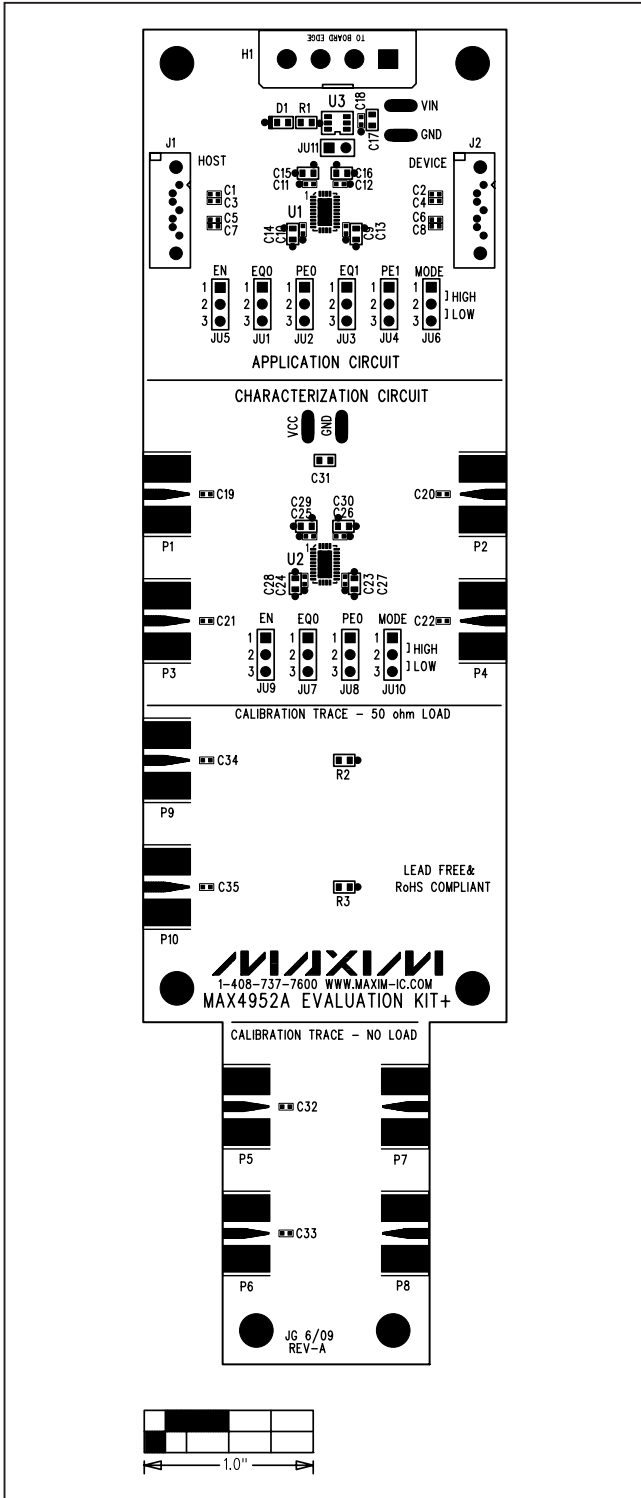

Figure 2. MAX4952A EV Kit Component Placement Guide—Component Side

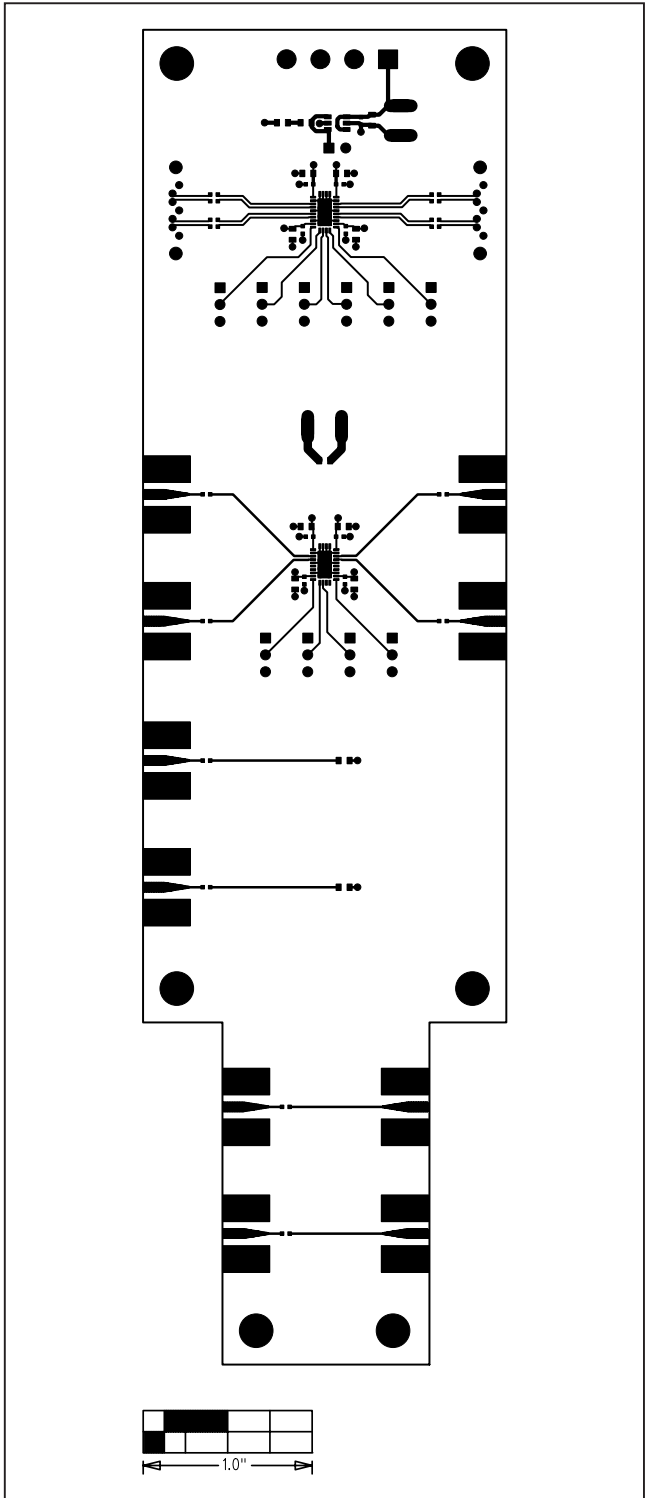

Figure 3. MAX4952A EV Kit PCB Layout—Component Side

MAX4952A Evaluation Kit

Evaluates: MAX4952A

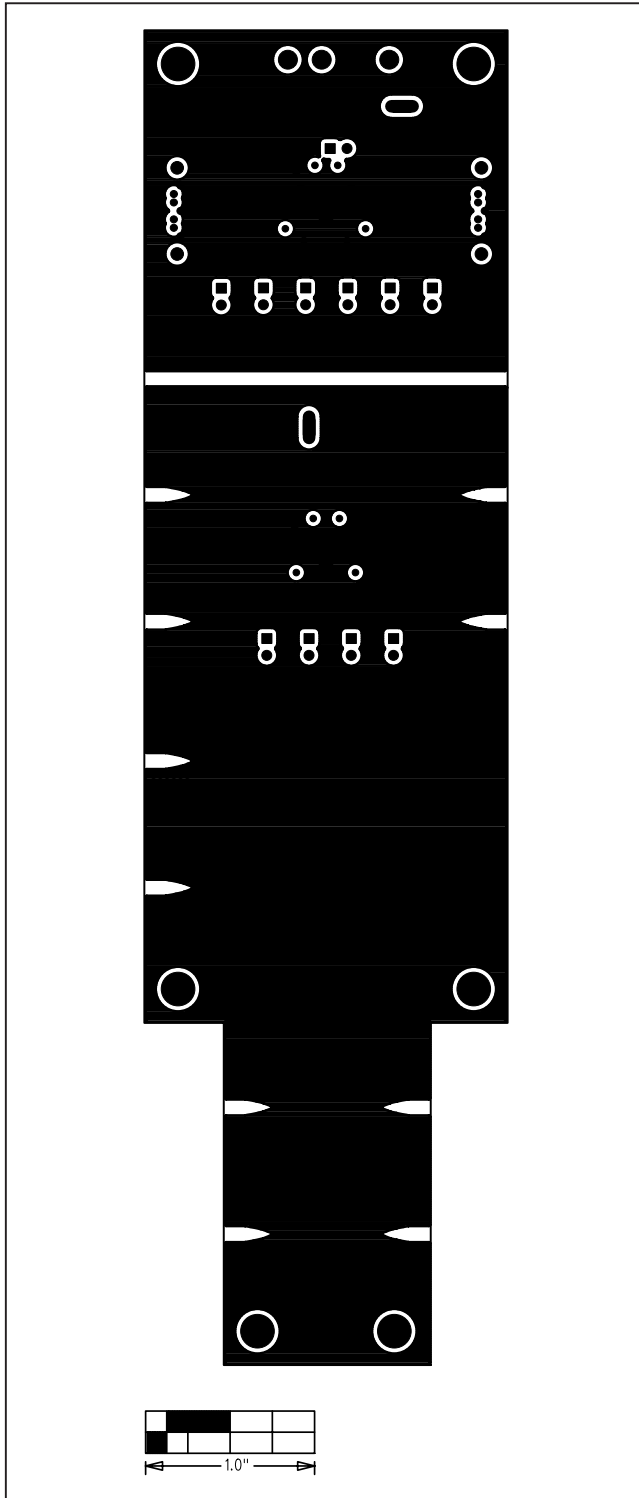

Figure 4. MAX4952A EV Kit PCB Layout—Inner Layer 2

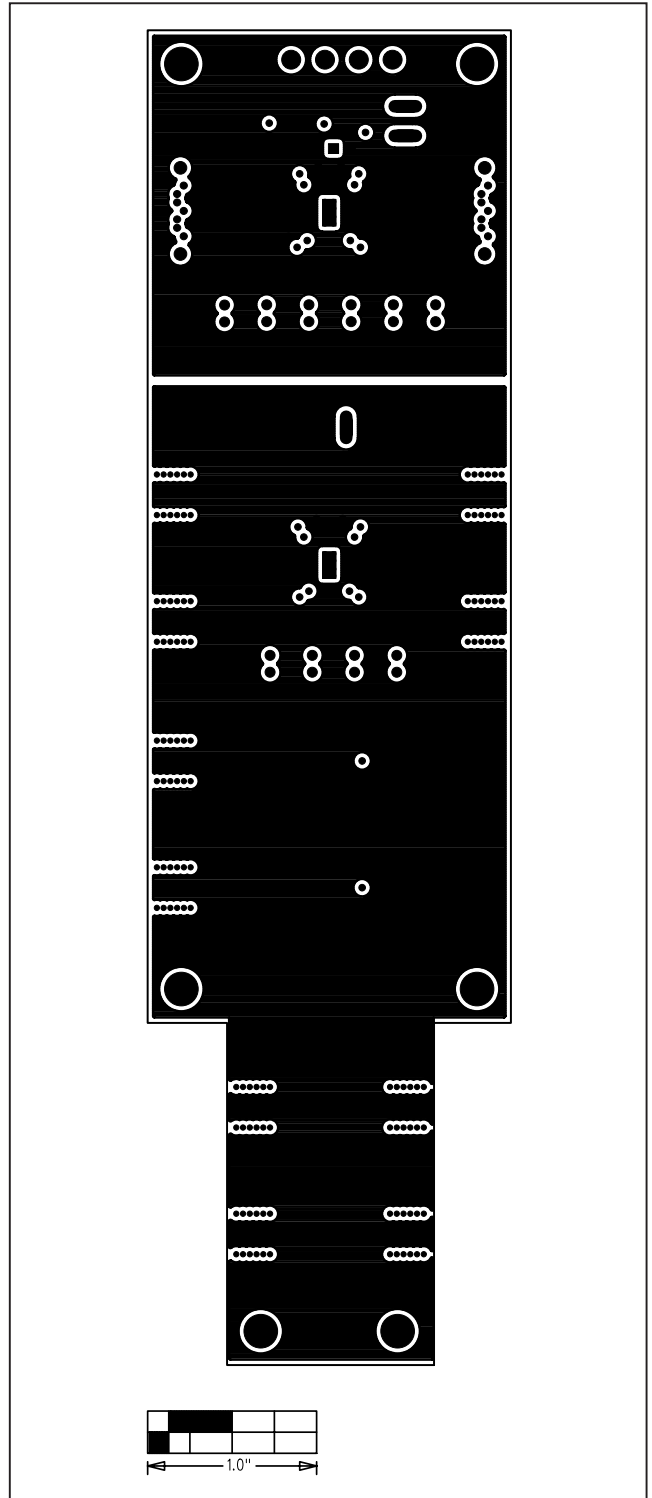

Figure 5. MAX4952A EV Kit PCB Layout—Inner Layer 3

MAX4952A Evaluation Kit

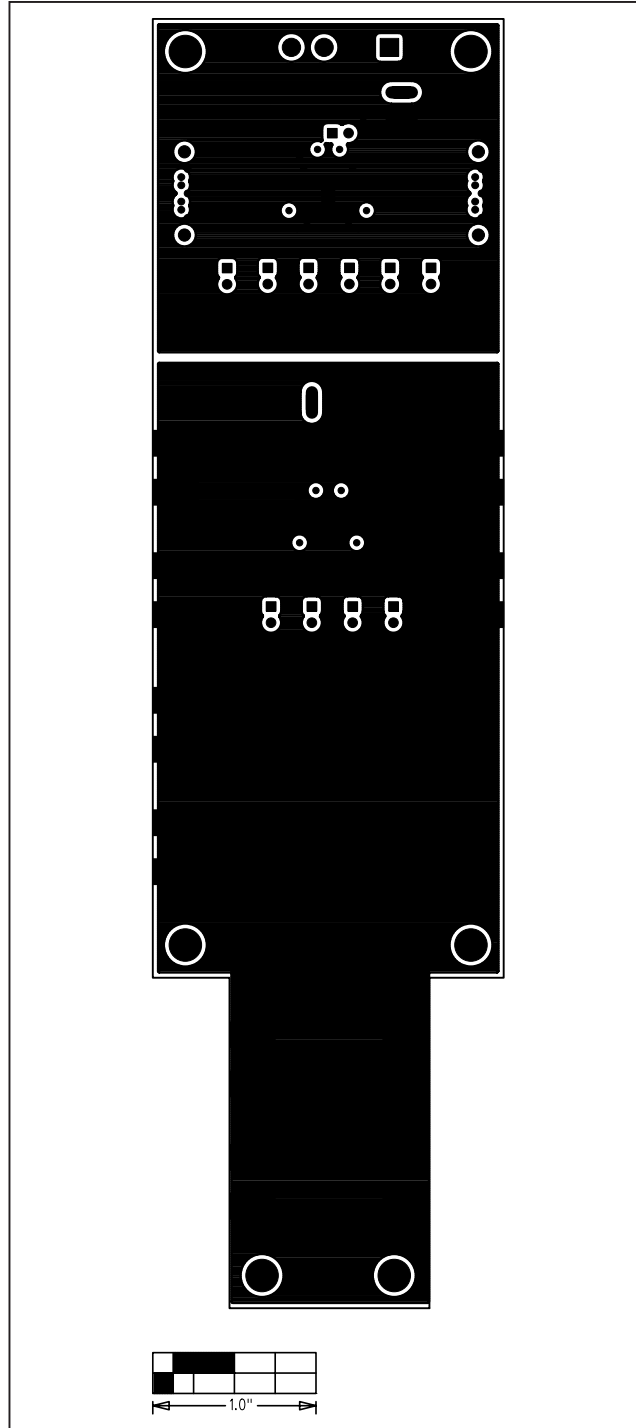

Figure 6. MAX4952A EV Kit PCB Layout—Solder Side

Maxim cannot assume responsibility for use of any circuitry other than circuitry entirely embodied in a Maxim product. No circuit patent licenses are implied. Maxim reserves the right to change the circuitry and specifications without notice at any time.

10 **Maxim Integrated Products, 120 San Gabriel Drive, Sunnyvale, CA 94086 408-737-7600**



Стандарт Электрон Связь

Мы молодая и активно развивающаяся компания в области поставок электронных компонентов. Мы поставляем электронные компоненты отечественного и импортного производства напрямую от производителей и с крупнейших складов мира.

Благодаря сотрудничеству с мировыми поставщиками мы осуществляем комплексные и плановые поставки широчайшего спектра электронных компонентов.

Собственная эффективная логистика и склад в обеспечивает надежную поставку продукции в точно указанные сроки по всей России.

Мы осуществляем техническую поддержку нашим клиентам и предпродажную проверку качества продукции. На все поставляемые продукты мы предоставляем гарантию .

Осуществляем поставки продукции под контролем ВП МО РФ на предприятия военно-промышленного комплекса России , а также работаем в рамках 275 ФЗ с открытием отдельных счетов в уполномоченном банке. Система менеджмента качества компании соответствует требованиям ГОСТ ISO 9001.

Минимальные сроки поставки, гибкие цены, неограниченный ассортимент и индивидуальный подход к клиентам являются основой для выстраивания долгосрочного и эффективного сотрудничества с предприятиями радиоэлектронной промышленности, предприятиями ВПК и научно-исследовательскими институтами России.

С нами вы становитесь еще успешнее!

Наши контакты:

Телефон: +7 812 627 14 35

Электронная почта: sales@st-electron.ru

Адрес: 198099, Санкт-Петербург,
Промышленная ул, дом № 19, литера Н,
помещение 100-Н Офис 331