

HSMC SATA RAID board [AB12-HSMCRAID]

Manual [Ver1.0E]

Introduction

Thank you for choosing HSMC SATA RAID board [Part Number: AB12-HSMCRAID] (“RAID board” in this manual.)
 The RAID board is compliant with HSMC standard of Altera and provides 8 SATA channels at maximum by high speed serial interface in HSMC so that user can build SATA RAID prototype system.
 The RAID board can directly connect with 8 pcs of 2.5”-SATA drive. User can supply power to the connected SATA drive via 4-pin ATX Standard power connector.
 On-board 150MHz low-jitter differential oscillator will supply high-quality reference SATA clock to the refclk input of FPGA via HSMC I/F (CLKIN2p/n).

Board Appearance

The RAID board size is 78mm width and 90mm length.
 Following figure-1 and figure-2 shows component side and solder side appearance respectively.

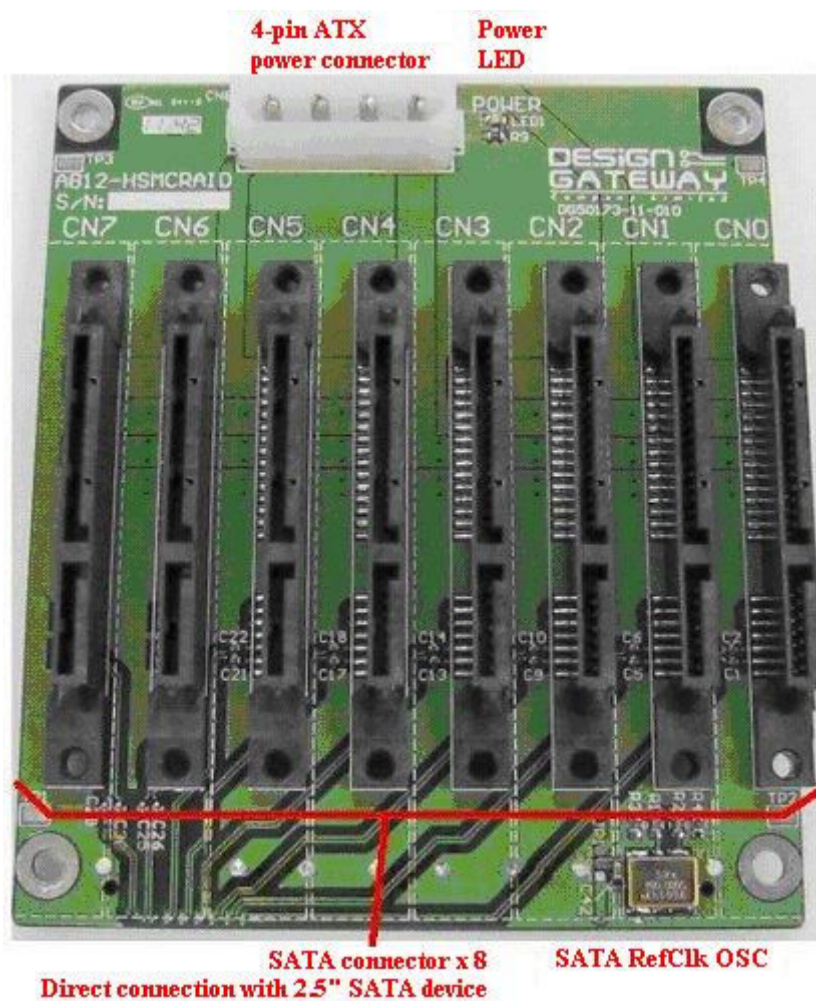

Figure-1: AB12-HSMCRAID component side

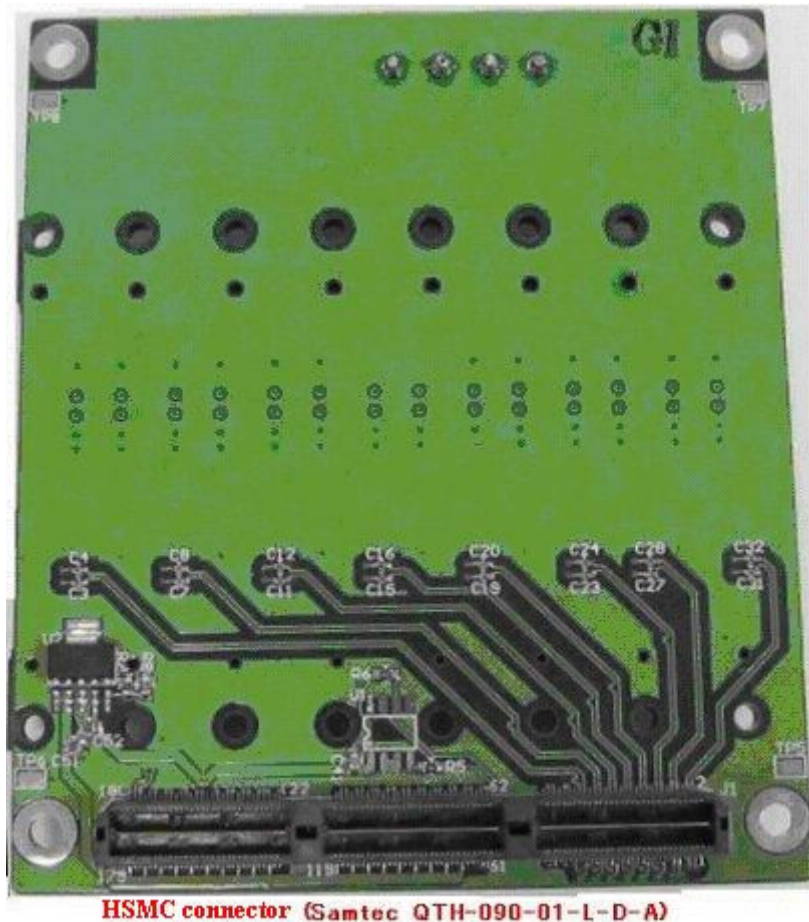

Figure-2: AB12-HSMCRAID solder side

Connection to the FPGA board

Connect the RAID board with HSMC connector on the FPGA board.

For 2.5"-SATA drive connection, user can directly connect SATA drive with CN0 – CN7 SATA connector on the RAID board.

Use 4-pin ATX Standard power connector for SATA drive power supply.

User must check that all SATA drives, RAID board and FPGA board are powered off when remove or connect.

To connect 3.5"-SATA drive, use SATA general extension cable. Following general extension cable is suitable for 3.5" usage.

Vendor: AREA (Setagaya Denki)

Product Number: AR-S005S

URL : <http://www.area-powers.jp/denki/cable/s005s.htm>

Vendor: AINEX

Product Number: SAT-15EXPA

URL : <http://www.ainex.jp/products/sat-15expa.htm>

When user want to assign SATA channel of the RAID board as a SATA Device to connect with SATA Host-PC, use above extension cable along with the following crossover adapter provided from DesignGateway.

Vendor: DesignGateway

Product Number: AB02-CROSSOVER

URL : <http://www.design-gateway.com/ABseries.html>

Pin Assignment

Pin assignment of HSMC on the RAID board is listed following table-1.

| HSMC Pin# (*1) | Samtec Pin# (*1) | HSMC definition | Signal Name | RAID Bd connection destination |
|----------------|------------------|-----------------|-------------|--------------------------------|
| | | | | |
| 1 | 1 | TX_P7 | HT7P | CN7-S2 (TX Pos) |
| 2 | 2 | RX_P7 | HR7P | CN7-S6 (RX Pos) |
| 3 | 3 | TX_N7 | HT7N | CN7-S3 (TX Neg) |
| 4 | 4 | RX_N7 | HR7N | CN7-S5 (RX Neg) |
| | | | | |
| 5 | 7 | TX_P6 | HT6P | CN6-S2 (TX Pos) |
| 6 | 8 | RX_P6 | HR6P | CN6-S6 (RX Pos) |
| 7 | 9 | TX_N6 | HT6N | CN6-S3 (TX Neg) |
| 8 | 10 | RX_N6 | HR6N | CN6-S5 (RX Neg) |
| | | | | |
| 9 | 13 | TX_P5 | HT5P | CN5-S2 (TX Pos) |
| 10 | 14 | RX_P5 | HR5P | CN5-S6 (RX Pos) |
| 11 | 15 | TX_N5 | HT5N | CN5-S3 (TX Neg) |
| 12 | 16 | RX_N5 | HR5N | CN5-S5 (RX Neg) |
| | | | | |
| 13 | 19 | TX_P4 | HT4P | CN4-S2 (TX Pos) |
| 14 | 20 | RX_P4 | HR4P | CN4-S6 (RX Pos) |
| 15 | 21 | TX_N4 | HT4N | CN4-S3 (TX Neg) |
| 16 | 22 | RX_N4 | HR4N | CN4-S5 (RX Neg) |
| | | | | |
| 17 | 25 | TX_P3 | HT3P | CN3-S2 (TX Pos) |
| 18 | 26 | RX_P3 | HR3P | CN3-S6 (RX Pos) |
| 19 | 27 | TX_N3 | HT3N | CN3-S3 (TX Neg) |
| 20 | 28 | RX_N3 | HR3N | CN3-S5 (RX Neg) |
| | | | | |
| 21 | 31 | TX_P2 | HT2P | CN2-S2 (TX Pos) |
| 22 | 32 | RX_P2 | HR2P | CN2-S6 (RX Pos) |
| 23 | 33 | TX_N2 | HT2N | CN2-S3 (TX Neg) |
| 24 | 34 | RX_N2 | HR2N | CN2-S5 (RX Neg) |
| | | | | |
| 25 | 37 | TX_P1 | HT1P | CN1-S2 (TX Pos) |
| 26 | 38 | RX_P1 | HR1P | CN1-S6 (RX Pos) |
| 27 | 39 | TX_N1 | HT1N | CN1-S3 (TX Neg) |
| 28 | 40 | RX_N1 | HR1N | CN1-S5 (RX Neg) |
| | | | | |
| 29 | 43 | TX_P0 | HT0P | CN0-S2 (TX Pos) |
| 30 | 44 | RX_P0 | HR0P | CN0-S6 (RX Pos) |
| 31 | 45 | TX_N0 | HT0N | CN0-S3 (TX Neg) |
| 32 | 46 | RX_N0 | HR0N | CN0-S5 (RX Neg) |
| | | | | |
| 156 | 176 | CLKIN2P | SCKN | (via R1) X1-5 (*2) |
| 158 | 178 | CLKIN2N | SCKP | (via R2) X1-4 (*2) |

Table1: HSMC pin assignment of AB12-HSMCRAID board

Note:

(*1) HSMC Pin# is pin number defined in HSMC standard, while Samtec Pin# is pin number of connector specification.

(*2) 150MHz SATA reference clock of CLKIN2P/N is reversed in its polarity due to the board trace, however, this polarity inversion is no problem because differential clock waveform is symmetrical.



Disclaimer

DesignGateway is exempted from any damage to the connected SATA device or FPGA board.
DesignGateway does not guarantee transfer speed performance.

[Inquiry]

URL : <http://www.design-gateway.com/>

Email : <mailto:sales@design-gateway.com>

Revision History

| Revision | Date | Description |
|----------|-------------|------------------------|
| 1.0E | 13-Jul-2012 | Release English manual |

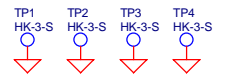
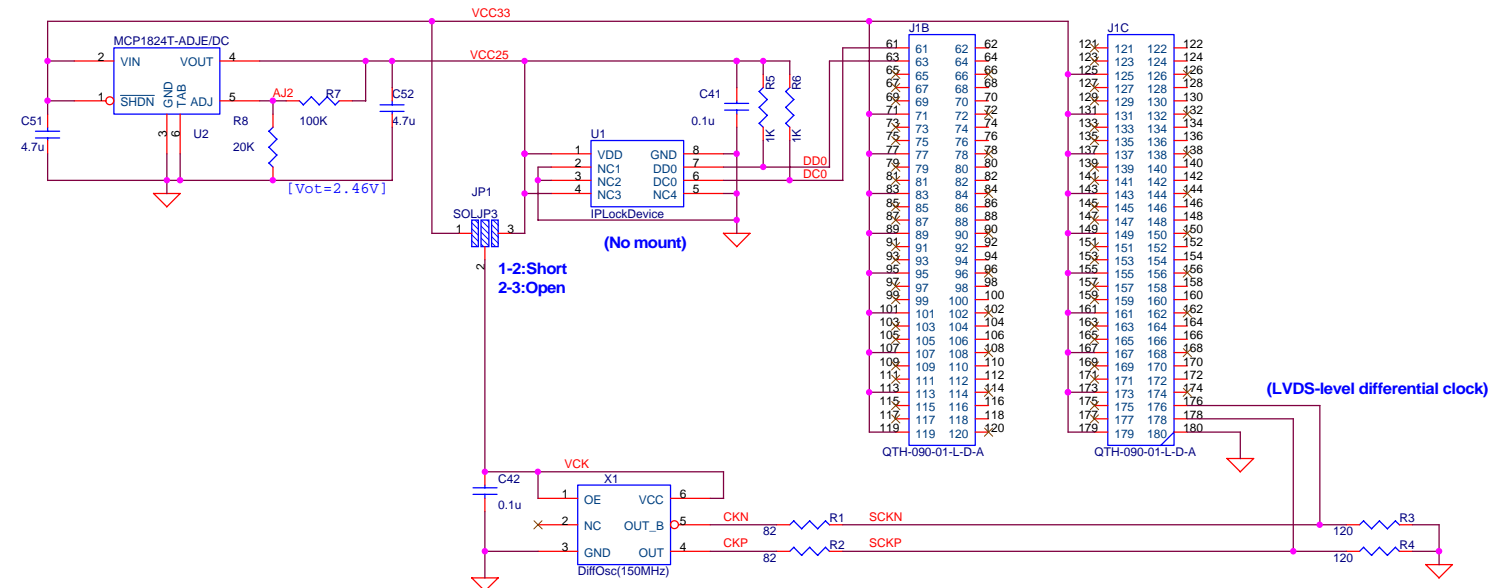
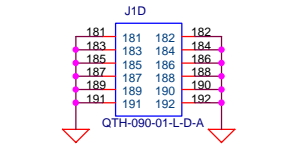
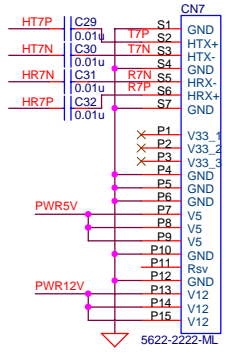
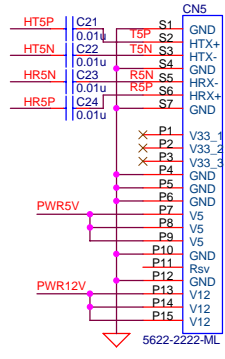
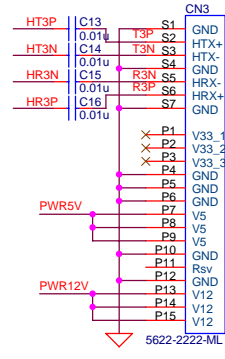
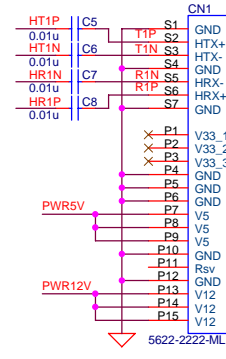
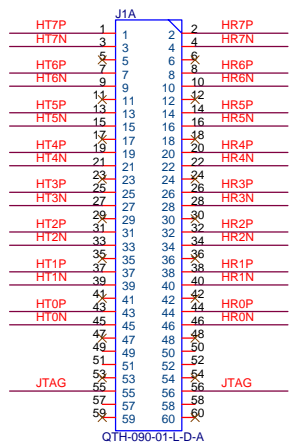
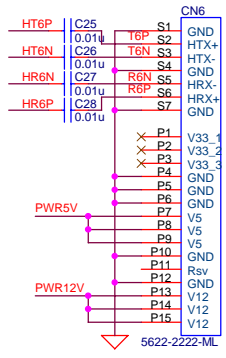
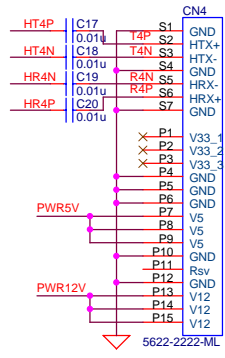
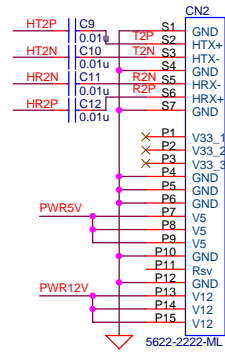
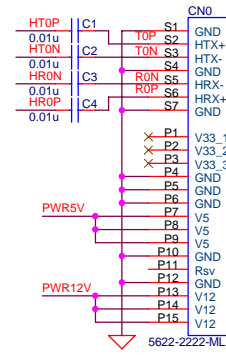
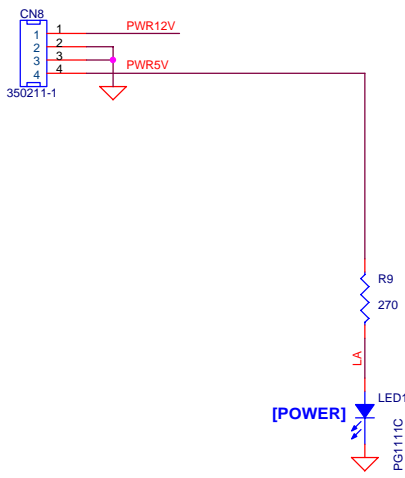

Component side GND test pin

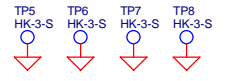

Solder side GND test pin

| | | | |
|-------|--------------------------|-------|--------|
| Title | | | RAID |
| Size | Document Number | Rev | |
| A3 | AB12-HSMCRAID | 1.0 | |
| Date: | Friday, January 13, 2012 | Sheet | 1 of 1 |



Стандарт Электрон Связь

Мы молодая и активно развивающаяся компания в области поставок электронных компонентов. Мы поставляем электронные компоненты отечественного и импортного производства напрямую от производителей и с крупнейших складов мира.

Благодаря сотрудничеству с мировыми поставщиками мы осуществляем комплексные и плановые поставки широчайшего спектра электронных компонентов.

Собственная эффективная логистика и склад в обеспечивает надежную поставку продукции в точно указанные сроки по всей России.

Мы осуществляем техническую поддержку нашим клиентам и предпродажную проверку качества продукции. На все поставляемые продукты мы предоставляем гарантию .

Осуществляем поставки продукции под контролем ВП МО РФ на предприятия военно-промышленного комплекса России , а также работаем в рамках 275 ФЗ с открытием отдельных счетов в уполномоченном банке. Система менеджмента качества компании соответствует требованиям ГОСТ ISO 9001.

Минимальные сроки поставки, гибкие цены, неограниченный ассортимент и индивидуальный подход к клиентам являются основой для выстраивания долгосрочного и эффективного сотрудничества с предприятиями радиоэлектронной промышленности, предприятиями ВПК и научно-исследовательскими институтами России.

С нами вы становитесь еще успешнее!

Наши контакты:

Телефон: +7 812 627 14 35

Электронная почта: sales@st-electron.ru

Адрес: 198099, Санкт-Петербург,
Промышленная ул, дом № 19, литера Н,
помещение 100-Н Офис 331