

---

## Description

The configurator in-system programming cable (ISP cable) is a PC-only based cable that attaches to the parallel port of a computer. This cable can be used to download and verify configuration data cascading up to 8 devices. This cable allows designers to quickly and economically program Atmel's family of AT17 configuration memories. It also provides support for new devices in the AT17 family prior to third-party programmer support being available. Therefore, it is a truly portable solution that allows engineers to work from their lab bench or office.

## Supported Devices

The AT17 series configurators can interface with many SRAM-based FPGA families. This document is limited to example implementations for the following families:

- Atmel – AT94K(FPSLIC), AT40K, AT6K
- Xilinx – XC4000, XC5200, Spartan®, Spartan2, Virtex®, VirtexE
- Altera – EPF6K, EPF8K, EPF10K
- Cypress – Delta39K15, 39K30, 39K50, 39K100, 39K165, 39K200

## Software Support

Make sure to use the latest CPS software (<http://www.atmel.com/atmel/products/prod185.htm>). CPS is used to program configurators and supports both the ATDH2200E programming board and this ISP cable. CPS also includes a conversion utility which supports Cypress, Xilinx and Altera file formats. The software, in conjunction with Atmel ISP cable, can be used to download an Atmel, Cypress, Xilinx or Altera programming file directly to Atmel's configurator(s).

- CPS – Configurator Programming System
- GUI Bbased Interface
- Supports Windows® 95/98/2000 and Windows NT®
- Supports up to 8 devices
- Supports programming reset polarity
- Verification routines to validate programming
- Accepts HEX, MCS, POF, RBF, HXU and BST file formats
- Online help
- Ability to enable or disable internal oscillator

For specific information on using the CPS software, refer to the *ATDH2200E Programming Kit User Guide*.



---

## In-System Programming Cable

---

## ATDH2225 FPGA Configuration EEPROM Memory



## Connecting Cable to Target System

The cable draws its power from the target system through VCC and GND. Therefore, power to the cable, as well as to the target FPGA, must be stable. Do not connect any signals before connecting VCC and GND. Connect the programming dongle to your printer parallel port. Connect the other end with 10-pin header to your target system (Figure 1). Your target system should have the 10-pin header pin layout as follow in order to match the download cable (Figure 2). The pin 9 of the 10-pin header on the target system is a key pin; therefore, it is cut off. The control signals generated by the software are fed to the header. The programming algorithms written by Atmel can be used to program an AT17 device in-system.

**Figure 1.** In-System Programming Application

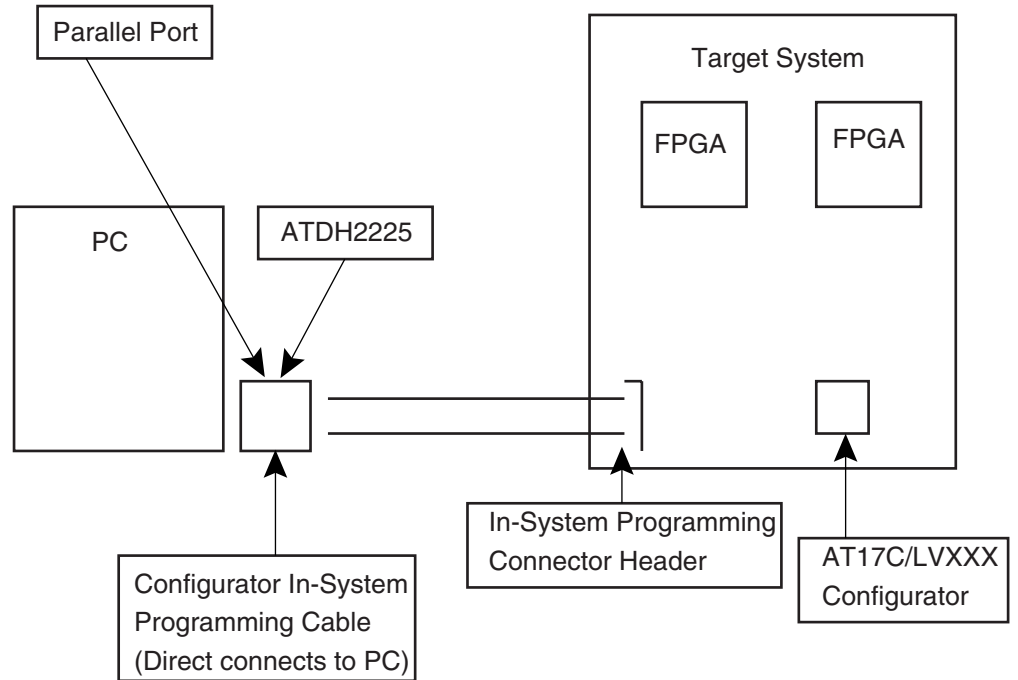

**Figure 2.** In-System Programming Header

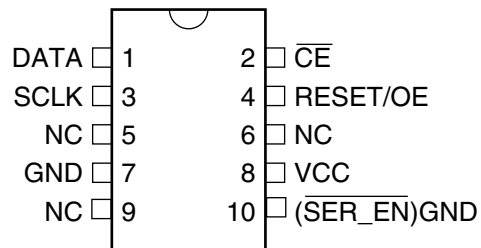

**Table 1.** 10-pin Header Pin Location on Target Board

1(DATA)	2( $\overline{CE}$ )
3(SCLK)	4(RESET/OE)
5(SW1)	6(SW2)
7(GND)	8(VCC)
9(NC)	10(SER_EN/GND)

- Notes:
1. Pin 10 activates "SER\_EN" on target board.
  2. Pin 9 is the polarizing pin (cut off).
  3. The 10-pin header is 0.1" spacing

Pin 5 and Pin 6 of the 10-pin header are the two signals which are able to decode for cascading up to 8 devices. The latest CPS software has the ability to control the 2 signals SW1, SW2 and by using the A2 pin of the device, you can select up to 8 devices. Therefore, you could use a 2-to-4 decoder to cascade 8 devices using our existing ISP circuit (see Figure 3).

**Figure 3.** ISP of Cascaded AT17C/LV002s in AT40K FPGA Applications

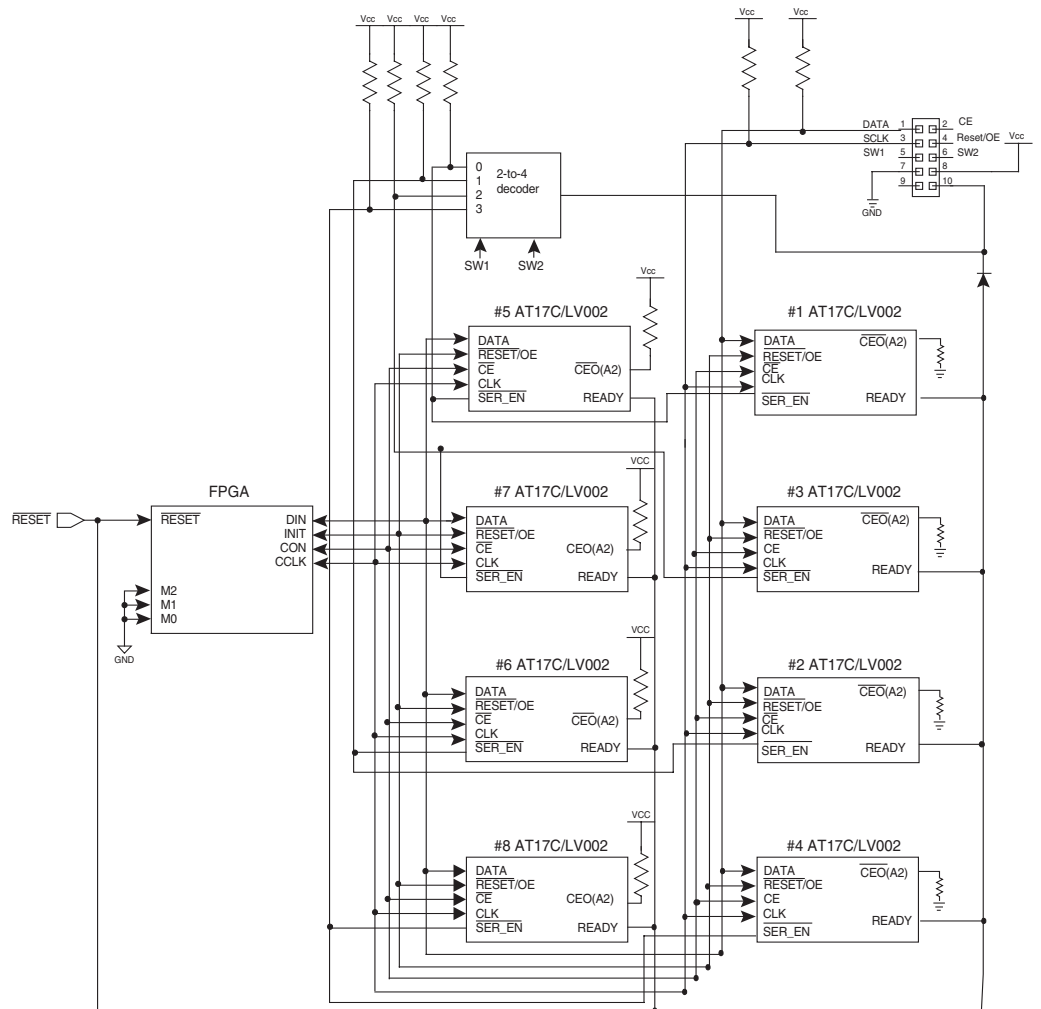

**Table 2.** 2 Devices

Device	A2
Device #1	pull down
Device #2	pull up

Note: No additional logic required, SW1 and SW2 not used.

**Table 3.** 4 Devices

Device	SW1	A2
Device #1	0	pull down
Device #2	1	pull down
Device #3	0	pull up
Device #4	1	pull up

Note: SW1 and some additional logic required for selecting up to 4 devices.

**Table 4.** 8 Devices

Device	SW1	SW2	A2
Device #1	0	0	pull down
Device #2	0	1	pull down
Device #3	1	0	pull down
Device #4	1	1	pull down
Device #5	0	0	pull up
Device #6	0	1	pull up
Device #7	1	0	pull up
Device #8	1	1	pull up

Note: SW1, SW2 and some additional logic required for selecting up to 8 devices.

**Table 5.** For 020 Max. is 4 Devices

Device	SW2	SW1
Device #1	0	0
Device #2	0	1
Device #3	1	0
Device #4	1	1

Note: 2 to 4 devices and some additional logic required for selecting up to 4 devices.

The AT17C/LV020 device is implemented using two 1-Mb Configurator EEPROMs in a multi-chip module. The A2 pin of the first internal 1Mb is set to Low by the internal pull-down circuitry. An external 4.7 kΩ pull-up must be connected to the A2 pin of the second internal 1Mb in order to program the second device. To work with the AT17C/LV020 devices, A2 should always have a pull up on the target system. The CPS software will implement the correct A2 value to program both internal devices. In fact, to program an AT17C/LV020 is just like programming two 1-Mb Configurator EEPROMs in casacade configuration.

Due to the fact that the AT17C/LV002 device is a single-die solution, an external pull-up or pull-down resistor can be connected to the A2 pin in order to program the data to the device. As long as the software A2 setting is matched with the hardware A2 pin setting, the data can be programmed to the device.

The tables on page 4 allow you to select any device out of the 8 devices, which can work with the ISP download cable. The circuit is limited to example implementation for the Atmel vendor only. It is the same idea for Xilinx and Altera applications. In addition, user can still use the existing ISP circuit, which from the 2-megabit cascade document with the same ISP download cable.

## **Related Documents**

*ATDH2200E Programming Kit User Guide*

AT17C/LV device datasheet

*Programming Specification for Atmel's FPGA Serial Configuration Memories*

## **Technical Support**

Use the ATDH2200E Programming Kit User Guide

Review the Configurator FAQ at [www.atmel.com](http://www.atmel.com)

Contact your local Atmel representative or distributor who provided the ISP download cable for technical support

Contact your local Atmel FAE (available at most sales offices)

Contact the Atmel configurator technical support hotline:

(408) 436-4119 (9:00 AM - 6:00 PM PST)

E-mail Atmel configurator technical support: [configurator@atmel.com](mailto:configurator@atmel.com)

Fax your inquires to "Configurator Tech Support" at:

(408) 487-2637



# Schematic

This cable would perform ISP without the use of the ATDH2200 board. The software used would be CPS.

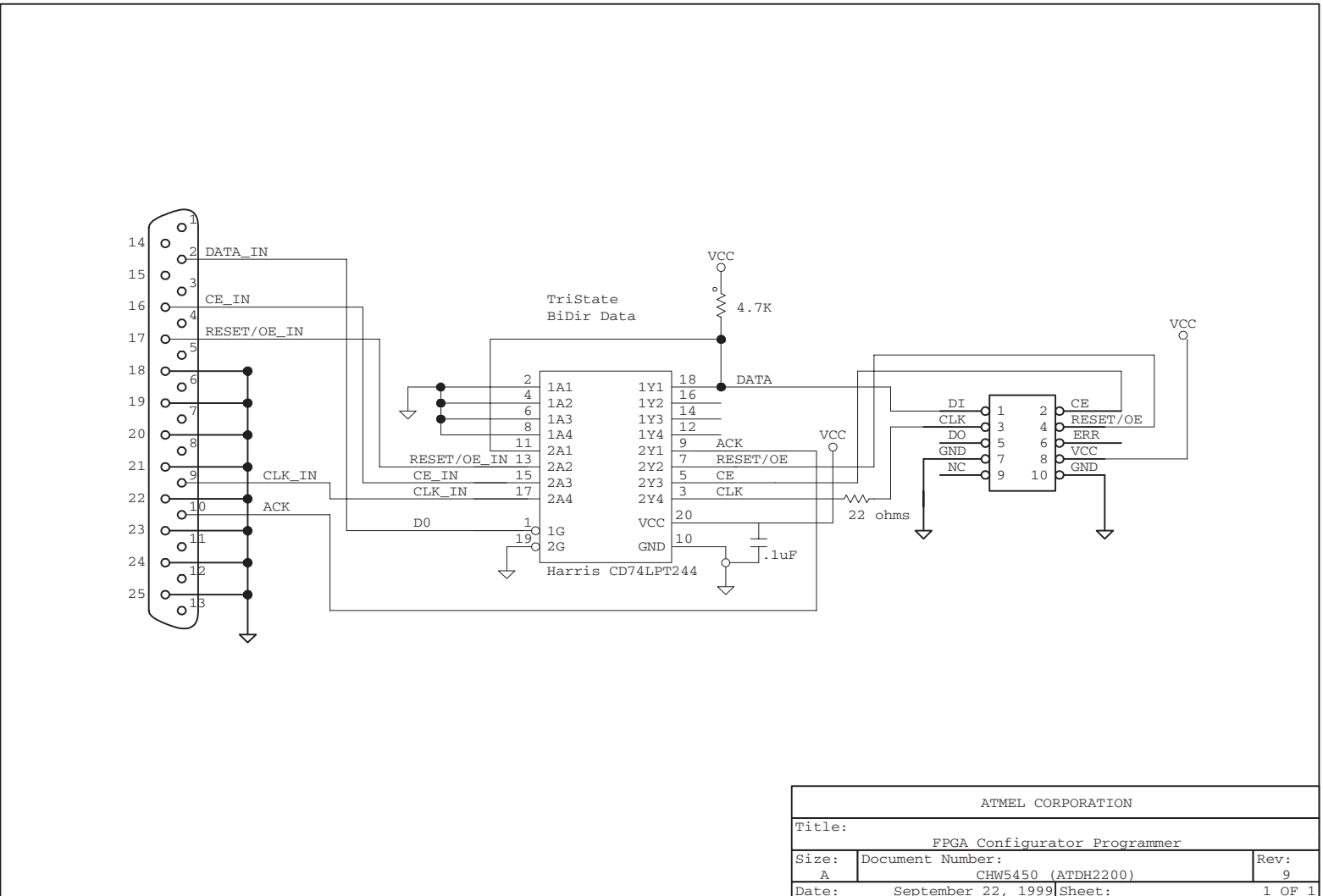



## Atmel Headquarters

### *Corporate Headquarters*

2325 Orchard Parkway  
San Jose, CA 95131  
TEL (408) 441-0311  
FAX (408) 487-2600

### *Europe*

Atmel SarL  
Route des Arsenaux 41  
Casa Postale 80  
CH-1705 Fribourg  
Switzerland  
TEL (41) 26-426-5555  
FAX (41) 26-426-5500

### *Asia*

Atmel Asia, Ltd.  
Room 1219  
Chinachem Golden Plaza  
77 Mody Road Tsimhatsui  
East Kowloon  
Hong Kong  
TEL (852) 2721-9778  
FAX (852) 2722-1369

### *Japan*

Atmel Japan K.K.  
9F, Tonetsu Shinkawa Bldg.  
1-24-8 Shinkawa  
Chuo-ku, Tokyo 104-0033  
Japan  
TEL (81) 3-3523-3551  
FAX (81) 3-3523-7581

## Atmel Operations

### *Atmel Colorado Springs*

1150 E. Cheyenne Mtn. Blvd.  
Colorado Springs, CO 80906  
TEL (719) 576-3300  
FAX (719) 540-1759

### *Atmel Rousset*

Zone Industrielle  
13106 Rousset Cedex  
France  
TEL (33) 4-4253-6000  
FAX (33) 4-4253-6001

### *Atmel Smart Card ICs*

Scottish Enterprise Technology Park  
East Kilbride, Scotland G75 0QR  
TEL (44) 1355-357-000  
FAX (44) 1355-242-743

### *Atmel Grenoble*

Avenue de Rochepleine  
BP 123  
38521 Saint-Egreve Cedex  
France  
TEL (33) 4-7658-3000  
FAX (33) 4-7658-3480

---

### *Atmel Configurator Hotline*

1-(408) 436-4119

### *Atmel Configurator e-mail*

configurator@atmel.com

### *FAQ*

Available on web site

### *Fax-on-Demand*

North America:  
1-(800) 292-8635

International:  
1-(408) 441-0732

### *e-mail*

literature@atmel.com

### *Web Site*

<http://www.atmel.com>

### *BBS*

1-(408) 436-4309

## © Atmel Corporation 2001.

Atmel Corporation makes no warranty for the use of its products, other than those expressly contained in the Company's standard warranty which is detailed in Atmel's Terms and Conditions located on the Company's web site. The Company assumes no responsibility for any errors which may appear in this document, reserves the right to change devices or specifications detailed herein at any time without notice, and does not make any commitment to update the information contained herein. No licenses to patents or other intellectual property of Atmel are granted by the Company in connection with the sale of Atmel products, expressly or by implication. Atmel's products are not authorized for use as critical components in life support devices or systems.

Spartan and Virtex are the registered trademarks of Xilinx Corporation.

Windows® 95/98/2000 and Windows NT® are the registered trademarks of Microsoft Corporation.

Other terms and product names may be trademarks of others.



Printed on recycled paper.

2288A-05/01/xM



## Стандарт Электрон Связь

Мы молодая и активно развивающаяся компания в области поставок электронных компонентов. Мы поставляем электронные компоненты отечественного и импортного производства напрямую от производителей и с крупнейших складов мира.

Благодаря сотрудничеству с мировыми поставщиками мы осуществляем комплексные и плановые поставки широчайшего спектра электронных компонентов.

Собственная эффективная логистика и склад в обеспечивает надежную поставку продукции в точно указанные сроки по всей России.

Мы осуществляем техническую поддержку нашим клиентам и предпродажную проверку качества продукции. На все поставляемые продукты мы предоставляем гарантию .

Осуществляем поставки продукции под контролем ВП МО РФ на предприятия военно-промышленного комплекса России , а также работаем в рамках 275 ФЗ с открытием отдельных счетов в уполномоченном банке. Система менеджмента качества компании соответствует требованиям ГОСТ ISO 9001.

Минимальные сроки поставки, гибкие цены, неограниченный ассортимент и индивидуальный подход к клиентам являются основой для выстраивания долгосрочного и эффективного сотрудничества с предприятиями радиоэлектронной промышленности, предприятиями ВПК и научно-исследовательскими институтами России.

С нами вы становитесь еще успешнее!

### Наши контакты:

**Телефон:** +7 812 627 14 35

**Электронная почта:** [sales@st-electron.ru](mailto:sales@st-electron.ru)

**Адрес:** 198099, Санкт-Петербург,  
Промышленная ул, дом № 19, литера Н,  
помещение 100-Н Офис 331