



## Selection Guide

| Part No. | Dice        | Lens Type      | Iv (mcd)<br>V= 9V |      | Viewing<br>Angle [1] |
|----------|-------------|----------------|-------------------|------|----------------------|
|          |             |                | Min.              | Typ. | 2θ1/2                |
| WP36BGD  | Green (GaP) | Green Diffused | 12                | 25   | 60°                  |

Notes:

1. θ1/2 is the angle from optical centerline where the luminous intensity is 1/2 of the optical peak value.
2. Luminous intensity value is traceable to the CIE127-2007 compliant national standards.

## Electrical / Optical Characteristics at TA=25°C

| Symbol            | Parameter                | Device | Min. | Typ. | Max. | Units | Test Conditions                                    |
|-------------------|--------------------------|--------|------|------|------|-------|--|
| λ <sub>peak</sub> | Peak Wavelength          | Green  |      | 565  |      | nm    |  |
| λ <sub>D</sub>    | Dominant Wavelength      | Green  |      | 568  |      | nm    |  |
| Δλ <sub>1/2</sub> | Spectral Line Half-width | Green  |      | 30   |      | nm    |  |
| I <sub>F</sub>    | Forward Current          | Green  | 8    | 22   |      | mA    | Min:V <sub>F</sub> =3.5V<br>Typ:V <sub>F</sub> =5V |
| I <sub>SON</sub>  | Supply Current           | Green  |      | 8    |      | mA    | V <sub>F</sub> =3.5V                               |
| I <sub>SON</sub>  | Supply Current           | Green  |      | 44   |      | mA    | V <sub>F</sub> =14V                                |
| f                 | Blink Frequency          | Green  | 1.5  |      | 3    | Hz    | V <sub>F</sub> =3.5V~14V                           |

Note:

1. Wavelength value is traceable to the CIE127-2007 compliant national standards.

## Absolute Maximum Ratings at TA=25°C

| Parameter                   | Green               | Units |
|-----------------------------|---------------------|-------|
| Power dissipation           | 310                 | mW    |
| Forward Voltage             | 14                  | V     |
| Reverse Voltage             | 0.5                 | V     |
| Operating Temperature       | -40°C To +70°C      |       |
| Storage Temperature         | -40°C To +85°C      |       |
| Lead Solder Temperature [1] | 260°C For 3 Seconds |       |
| Lead Solder Temperature [2] | 260°C For 5 Seconds |       |

Notes:

1. 2mm below package base.
2. 5mm below package base.

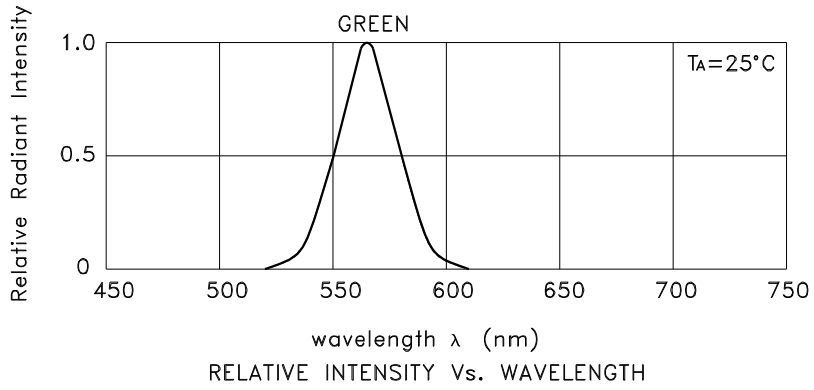

Green

WP36BGD

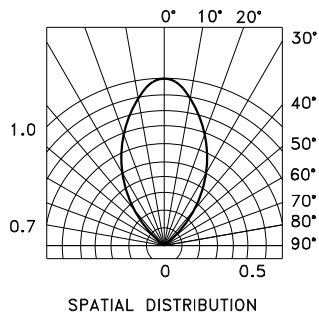
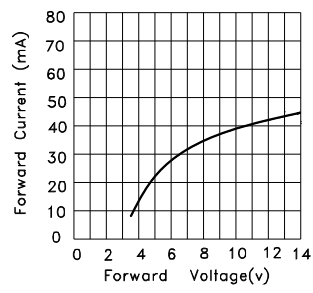
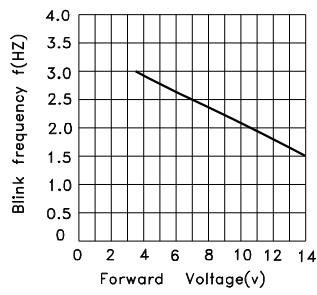

# Kingbright

## PACKING & LABEL SPECIFICATIONS

## WP36BGD

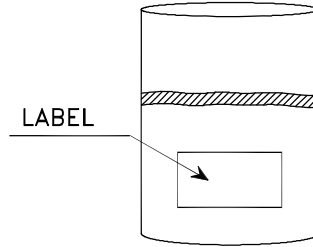
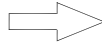
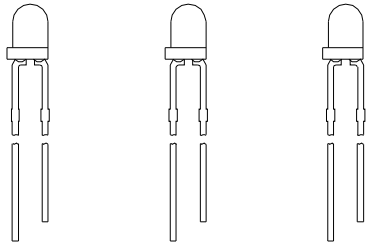

500PCS / BAG

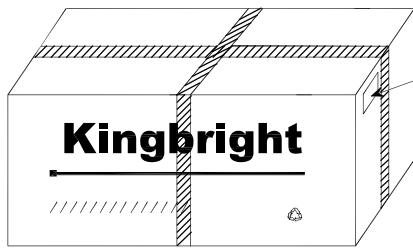

40K / 9# BOX

OUTSIDE LABEL

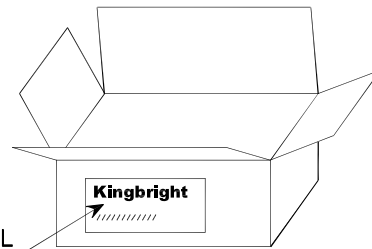
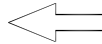

20K / 5# BOX

OUTSIDE LABEL

|  |      |                             |
|--|------|-----------------------------|
| <h1>Kingbright</h1>  |      |                             |
| P/NO:WP36Bxxx  |      |                             |
| QTY: 500 pcs   | Q.C. | Q C<br>xx xx xxxx<br>PASSED |
| S/N: XXXX  |      |                             |
| CODE: XXX  |      |                             |
| LOT NO:  |      |                             |
| <br>xxxxxxxxxxxxxxxxxxxxxxxxxxxx |      |                             |
| RoHS Compliant   |      |                             |

## PRECAUTIONS

1. The lead pitch of the LED must match the pitch of the mounting holes on the PCB during component placement. Lead-forming may be required to insure the lead pitch matches the hole pitch. Refer to the figure below for proper lead forming procedures. (Fig. 1)

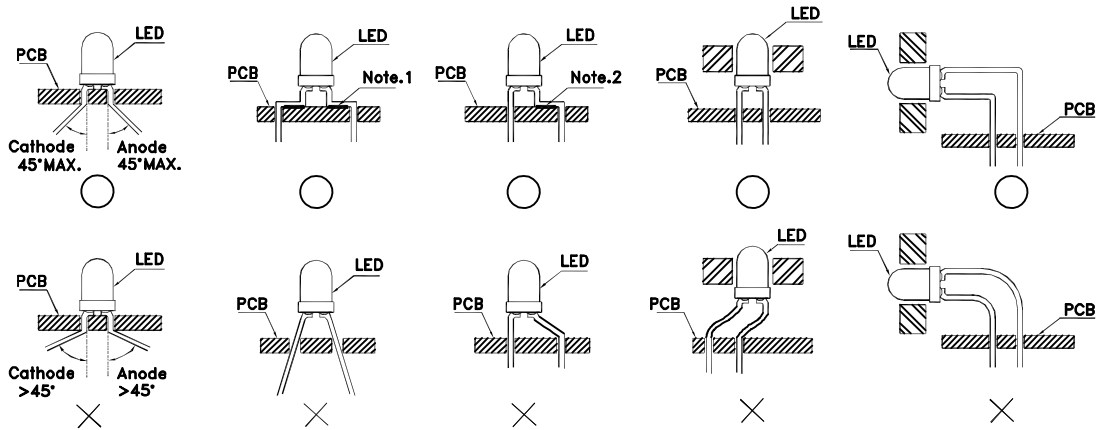

Fig.1

”○” Correct mounting method ”✗” Incorrect mounting method

2. When soldering wire to the LED, use individual heat-shrink tubing to insulate the exposed leads to prevent accidental contact short-circuit. (Fig.2)
3. Use stand-offs (Fig.3) or spacers (Fig.4) to securely position the LED above the PCB.



Fig. 2

Fig. 3

Fig. 4

4. Maintain a minimum of 2mm clearance between the base of the LED lens and the first lead bend. (Fig. 5 and 6)
5. During lead forming, use tools or jigs to hold the leads securely so that the bending force will not be transmitted to the LED lens and its internal structures. Do not perform lead forming once the component has been mounted onto the PCB. (Fig. 7)

6. Do not bend the leads more than twice. (Fig. 8)

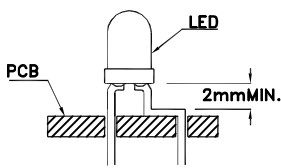

Fig. 5

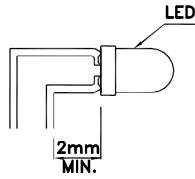

Fig. 6

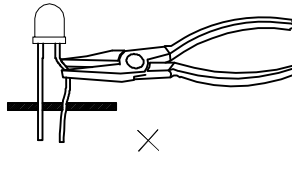

Fig. 7

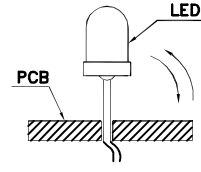
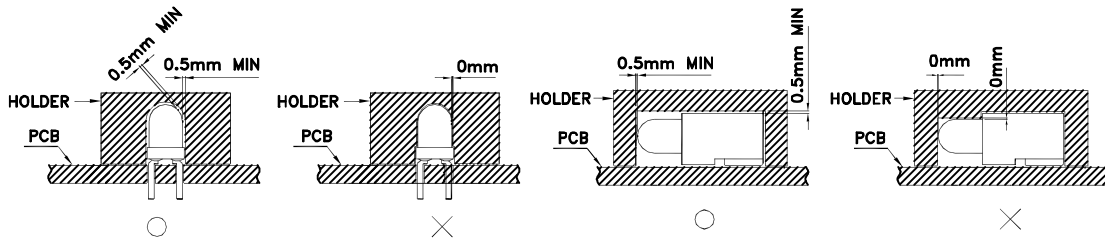

Fig. 8

7. During soldering, component covers and holders should leave clearance to avoid placing damaging stress on the LED during soldering.



8. The tip of the soldering iron should never touch the lens epoxy.

9. Through-hole LEDs are incompatible with reflow soldering.

10. If the LED will undergo multiple soldering passes or face other processes where the part may be subjected to intense heat, please check with Kingbright for compatibility.

11. Recommended Wave Soldering Profiles:

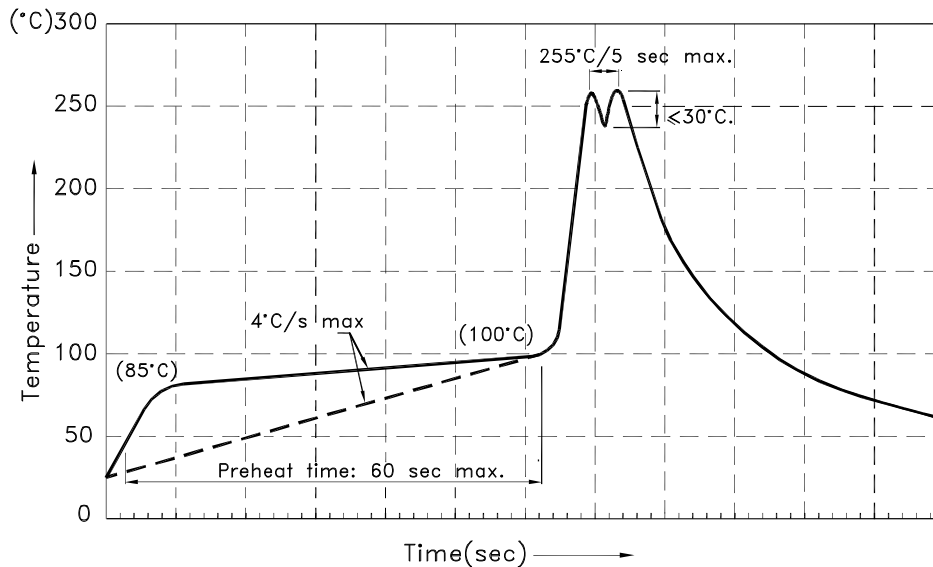

Notes:

1. Recommend pre-heat temperature of 105°C or less (as measured with a thermocouple attached to the LED pins) prior to immersion in the solder wave with a maximum solder bath temperature of 260°C
2. Peak wave soldering temperature between 245°C ~ 255°C for 3 sec (5 sec max).
3. Do not apply stress to the epoxy resin while the temperature is above 85°C.
4. Fixtures should not incur stress on the component when mounting and during soldering process.
5. SAC 305 solder alloy is recommended.
6. No more than one wave soldering pass.

All design applications should refer to Kingbright application notes available at <http://www.KingbrightUSA.com/ApplicationNotes>



## Стандарт Электрон Связь

Мы молодая и активно развивающаяся компания в области поставок электронных компонентов. Мы поставляем электронные компоненты отечественного и импортного производства напрямую от производителей и с крупнейших складов мира.

Благодаря сотрудничеству с мировыми поставщиками мы осуществляем комплексные и плановые поставки широчайшего спектра электронных компонентов.

Собственная эффективная логистика и склад в обеспечивает надежную поставку продукции в точно указанные сроки по всей России.

Мы осуществляем техническую поддержку нашим клиентам и предпродажную проверку качества продукции. На все поставляемые продукты мы предоставляем гарантию .

Осуществляем поставки продукции под контролем ВП МО РФ на предприятия военно-промышленного комплекса России , а также работаем в рамках 275 ФЗ с открытием отдельных счетов в уполномоченном банке. Система менеджмента качества компании соответствует требованиям ГОСТ ISO 9001.

Минимальные сроки поставки, гибкие цены, неограниченный ассортимент и индивидуальный подход к клиентам являются основой для выстраивания долгосрочного и эффективного сотрудничества с предприятиями радиоэлектронной промышленности, предприятиями ВПК и научно-исследовательскими институтами России.

С нами вы становитесь еще успешнее!

### Наши контакты:

**Телефон:** +7 812 627 14 35

**Электронная почта:** [sales@st-electron.ru](mailto:sales@st-electron.ru)

**Адрес:** 198099, Санкт-Петербург,  
Промышленная ул, дом № 19, литера Н,  
помещение 100-Н Офис 331