

8-Bit, 2-Port, Low Voltage Translator Bus Switch

Features

- Near-Zero propagation delay
- Low On-Resistance switches connect inputs to outputs
- 2.5V to 3.3V Supply voltage operation
- 2.5V or 1.8V switching
- Packaging (Pb-free & Green available):
 - 20-pin, 150-mil wide plastic QSOP (Q)
 - 20-pin, 173-mil wide plastic TSSOP (L)

Applications

- 3.3V to 2.5V level shifting (voltage translation)
- 2.5V to 1.8V level shifting (voltage translation)

Description

Pericom Semiconductor's PI3VT series of logic circuits are produced using the Company's advanced submicron CMOS technology, achieving industry leading performance.

The PI3VT3245 is a 2.5V or 3.3V 8-bit, 2-port bus switch designed with a low On-Resistance (5Ω). The switches are turned ON or enabled by the Bus Enable (\overline{BE}) input signal.

Given a 3.3V supply and an input voltage of 3.3V, the switch translates to an output voltage of 2.5V. Similarly, when operated with a 2.5V supply and given 2.5V inputs, the device translates the outputs to 1.8V.

Block Diagram

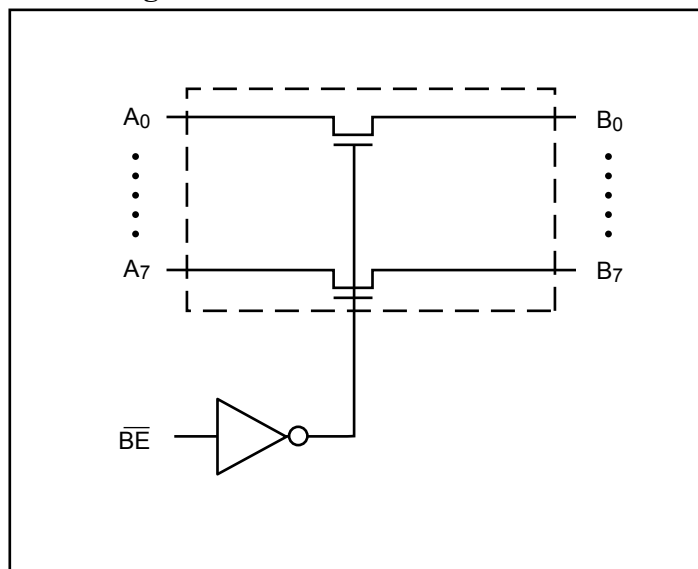

Pin Configuration

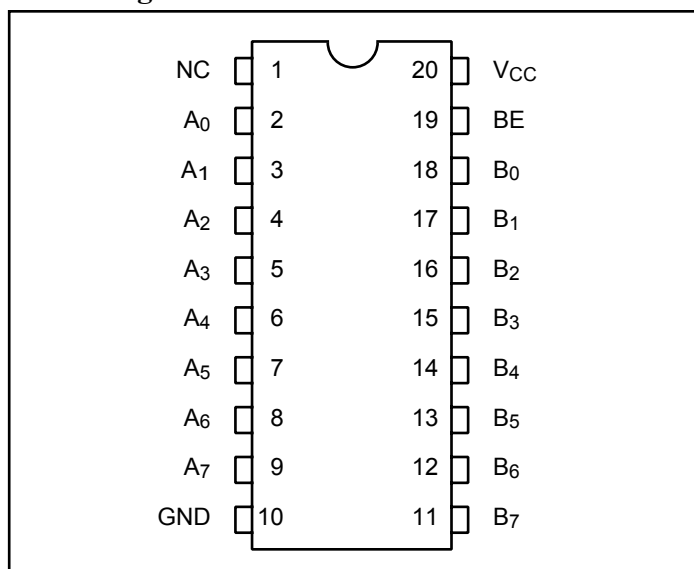

Truth Table⁽¹⁾

Function	\overline{BE}	A0-7
Disconnect	H	Hi-Z
Connect	L	B0-7

Notes:

1. H = High Voltage Level
L = Low Voltage Level
Hi-Z = High Impedance

Pin Description

Pin Name	Description
\overline{BE}	Bus Enable Input (Active Low)
A0-A7	Bus A
B0-B7	Bus B
V _{CC}	Power
GND	Ground

Maximum Ratings

(Above which the useful life may be impaired. For user guidelines, not tested.)

Storage Temperature	-65°C to +150°C
Ambient Temperature with Power Applied	-40°C to +85°C
Supply Voltage to Ground Potential.....	-0.5V to +4.6V
DC Input Voltage	-0.5V to +5.5V
DC Output Current.....	120mA
Power Dissipation	0.5W

Note:

Stresses greater than those listed under MAXIMUM RATINGS may cause permanent damage to the device. This is a stress rating only and functional operation of the device at these or any other conditions above those indicated in the operational sections of this specification is not implied. Exposure to absolute maximum rating conditions for extended periods may affect reliability.

DC Electrical Characteristics (Over Operating Range, $T_A = -40^\circ\text{C}$ to $+85^\circ\text{C}$, $V_{CC} = 3.3\text{V} \pm 10\%$)

Parameters	Description	Test Conditions ⁽¹⁾	Min.	Typ. ⁽²⁾	Max.	Units
V_{IH}	Input HIGH Voltage	Guaranteed logic HIGH level	2.0		$V_{CC} + 0.3\text{V}$	V
V_{IL}	Input LOW Voltage	Guaranteed logic LOW level	-0.5		0.8	
I_{IH}	Input HIGH Current	$V_{CC} = \text{Max.}, V_{IN} = V_{CC}$			± 1	μA
I_{IL}	Input LOW Current	$V_{CC} = \text{Max.}, V_{IN} = \text{GND}$			± 1	
I_{OZH}	High Impedance Output Current	$0 \leq A, B \leq V_{CC}$			± 1	
R_{ON}	Switch On-Resistance	$V_{CC} = \text{Min.}, V_{IN} = 0\text{V}, I_{ON} = -8\text{mA}$		5	8	Ω
		$V_{CC} = \text{Min.}, V_{IN} = 1.7\text{V}, I_{ON} = -8\text{mA}$		15	22	
		$V_{CC} = 2.3\text{V}, V_{IN} = 0\text{V}, I_{ON} = -8\text{mA}$		6	9	
		$V_{CC} = 2.3\text{V}, V_{IN} = 1.3\text{V}, I_{ON} = -8\text{mA}$		25	30	
V_p	Pass Voltage	$V_{IN} = V_{CC} = 3.3\text{V}, I_{OUT} = -5\mu\text{A}$	2.3	2.5	2.9	V
		$V_{IN} = V_{CC} = 2.5\text{V}, I_{OUT} = -5\mu\text{A}$		1.8		

Capacitance ($T_A = 25^\circ\text{C}$, $f = 1\text{MHz}$)

Parameters ⁽⁵⁾	Description	Test Conditions	Typ.	Units
C_{IN}	Input Capacitance	$V_{IN} = 0\text{V}$	3.5	pF
C_{OFF}	A/B Capacitance, Switch Off		5.0	
C_{ON}	A/B Capacitance, Switch On		11.2	

Notes:

- For Max. or Min. conditions, use appropriate value specified under Electrical Characteristics for the applicable device type.
- Typical values are at $V_{CC} = 3.3\text{V}$, $T_A = 25^\circ\text{C}$ ambient and maximum loading.
- Not more than one output should be shorted at one time. Duration of the test should not exceed one second.
- Measured by the voltage drop between A and B pin at indicated current through the switch. On-Resistance is determined by the lower of the voltages on the two (A,B) pins.
- This parameter is determined by device characterization but is not production tested.

Power Supply Characteristics

Parameters	Description	Test Conditions ⁽¹⁾		Min.	Typ. ⁽²⁾	Max.	Units
I _{CC}	Quiescent Power Supply Current	V _{CC} = Max.	V _{IN} = GND or V _{CC}			3	μA
ΔI _{CC}	Quiescent Current per Input HIGH		V _{IN} = 3V ⁽³⁾			50	

Notes:

- For Max. or Min. conditions, use appropriate value specified under Electrical Characteristics for the applicable device.
- Typical values are at V_{CC} = 3.3V, +25°C ambient.
- Per driven input (control input only); A and B pins do not contribute to ΔI_{CC}.

Switching Characteristics over 3.3V ±0.3V Operating Range

Parameters	Description	Conditions ⁽¹⁾	Com.		Units
			Min.	Max.	
t _{PLH} t _{PHL}	Propogation Delay ^(2,3) Ax to Bx	C _L = 50pF, R _L = 500Ω		0.25	ns
t _{PZH} t _{PZL}	Enable Time \overline{BE} to Ax or Bx	C _L = 50pF, R _L = 500Ω, R = 500Ω	1.5	9.8	
t _{PHZ} t _{PLZ}	Disable Time \overline{BE} to Ax or Bx		1.5	8.3	

Switching Characteristics over 2.5V ±0.2V Operating Range

Parameters	Description	Conditions ⁽¹⁾	Com.		Units
			Min.	Max.	
t _{PLH} t _{PHL}	Propogation Delay ^(2,3) Ax to Bx	C _L = 50pF, R _L = 500Ω		0.25	ns
t _{PZH} t _{PZL}	Enable Time \overline{BE} to Ax or Bx	C _L = 50pF, R _L = 500Ω, R = 500Ω	1.5	9.8	
t _{PHZ} t _{PLZ}	Disable Time \overline{BE} to Ax or Bx		1.5	8.3	

Notes:

- See test circuit and waveforms.
- This parameter is guaranteed but not tested on Propagation Delays.
- The bus switch contributes no propagational delay other than the RC delay of the On-Resistance of the switch and the load capacitance. The time constant for the switch alone is of the order of 0.25ns for 50pF load. Since this time constant is much smaller than the rise/fall times of typical driving signals, it adds very little propagational delay to the system. Propagational delay of the bus switch when used in a system is determined by the driving circuit on the driving side of the switch and its interaction with the load on the driven side.

Packaging Mechanical: 20-pin QSOP (Q)

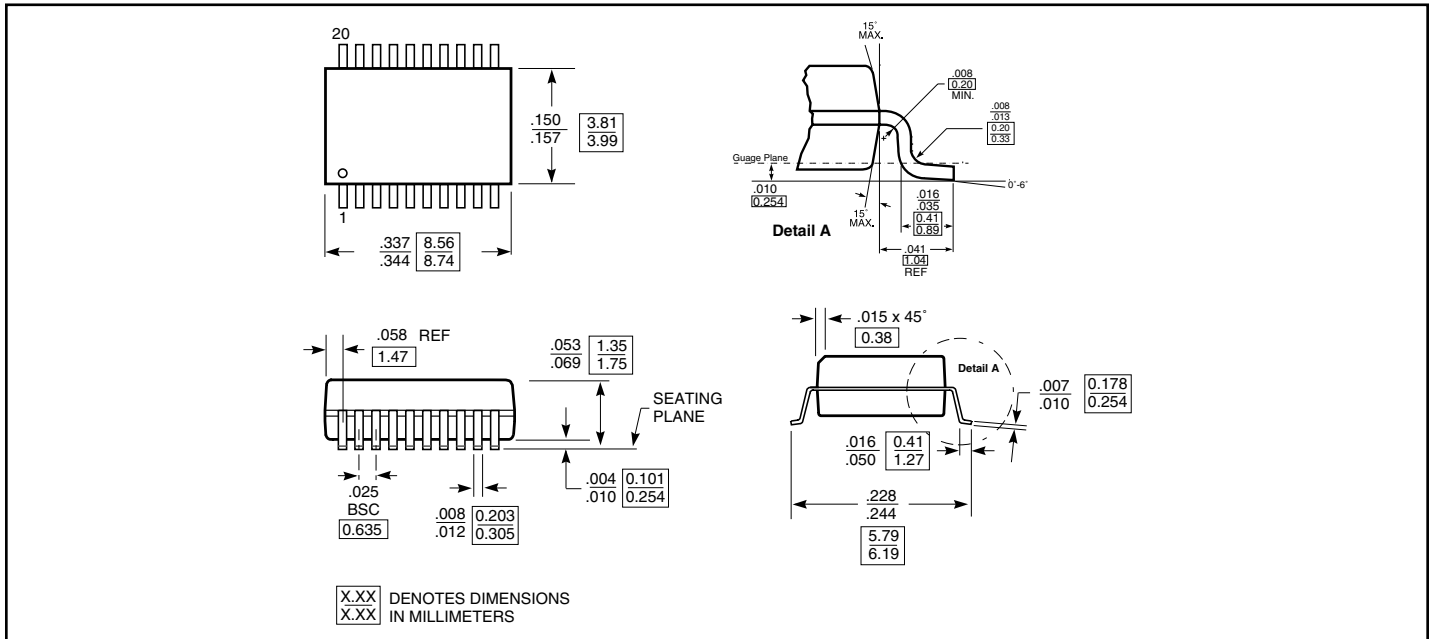

Packaging Mechanical: 20-pin TSSOP (L)

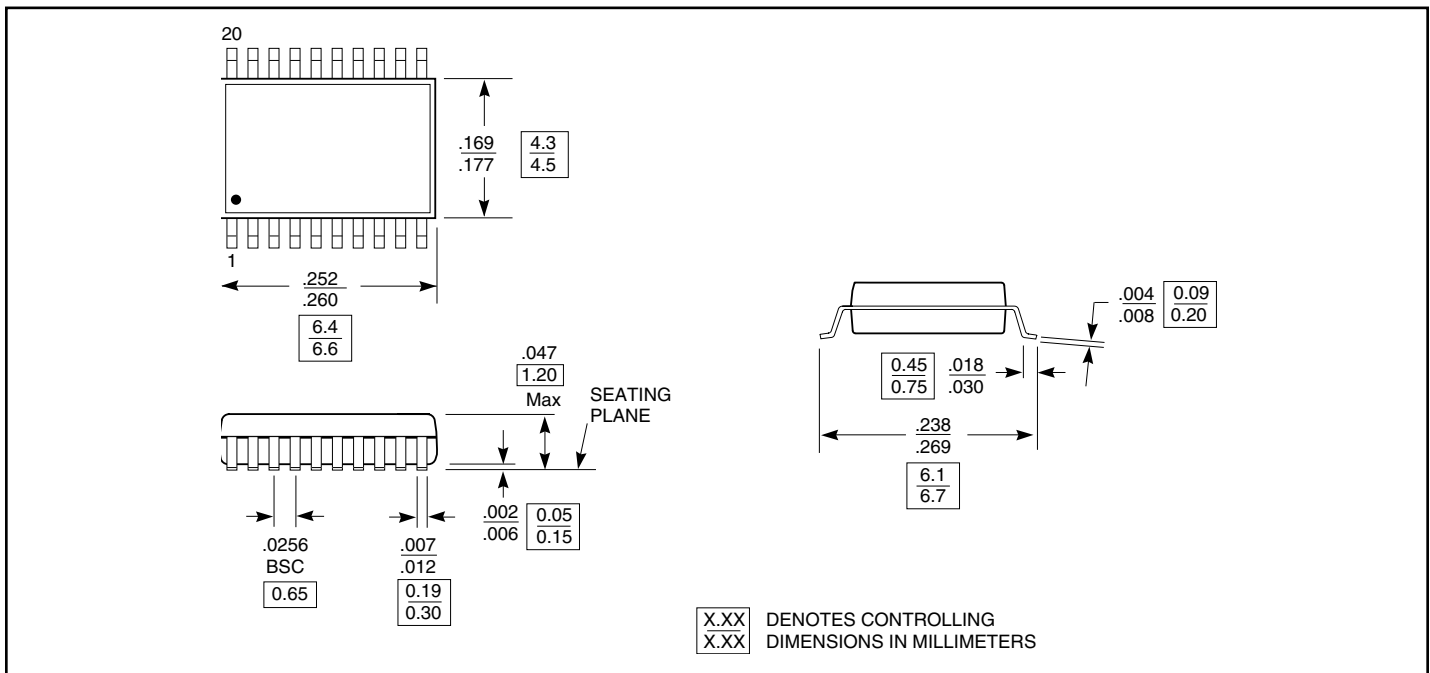

Ordering Information

Ordering Code	Packaging Code	Package Description
PI3VT3245L	L	20-pin TSSOP
PI3VT3245LE	L	Pb-free & Green, 20-pin TSSOP
PI3VT3245Q	Q	20-pin QSOP
PI3VT3245QE	Q	Pb-free & Green, 20-pin QSOP

Notes:

1. Thermal characteristics can be found on the company web site at www.pericom.com/packaging/



**Стандарт
Электрон
Связь**

Мы молодая и активно развивающаяся компания в области поставок электронных компонентов. Мы поставляем электронные компоненты отечественного и импортного производства напрямую от производителей и с крупнейших складов мира.

Благодаря сотрудничеству с мировыми поставщиками мы осуществляем комплексные и плановые поставки широчайшего спектра электронных компонентов.

Собственная эффективная логистика и склад в обеспечивает надежную поставку продукции в точно указанные сроки по всей России.

Мы осуществляем техническую поддержку нашим клиентам и предпродажную проверку качества продукции. На все поставляемые продукты мы предоставляем гарантию .

Осуществляем поставки продукции под контролем ВП МО РФ на предприятия военно-промышленного комплекса России , а также работаем в рамках 275 ФЗ с открытием отдельных счетов в уполномоченном банке. Система менеджмента качества компании соответствует требованиям ГОСТ ISO 9001.

Минимальные сроки поставки, гибкие цены, неограниченный ассортимент и индивидуальный подход к клиентам являются основой для выстраивания долгосрочного и эффективного сотрудничества с предприятиями радиоэлектронной промышленности, предприятиями ВПК и научно-исследовательскими институтами России.

С нами вы становитесь еще успешнее!

Наши контакты:

Телефон: +7 812 627 14 35

Электронная почта: sales@st-electron.ru

Адрес: 198099, Санкт-Петербург,
Промышленная ул, дом № 19, литера Н,
помещение 100-Н Офис 331