

PLEASE CHECK WWW.MOLEX.COM FOR LATEST PART INFORMATION

Part Number: [0739446001](#)
Status: **Active**
Overview: [hdm](#)
Description: 2.00mm (.079") Pitch HDM® Board-to-Board Backplane Header, Vertical, SMC, Solder Tail, Guide Pin Option, 72 Circuits

Documents:

[3D Model](#) [Product Specification PS-73670-9999 \(PDF\)](#)
[Drawing \(PDF\)](#) [RoHS Certificate of Compliance \(PDF\)](#)

Agency Certification

CSA LR19980
 UL E29179

General

Product Family Backplane Connectors
 Series [73944](#)
 Application Backplane
 Component Type PCB Header
 Overview [hdm](#)
 Product Name HDM®
 Style N/A

Physical

Circuits (Loaded) 72
 Circuits (maximum) 72
 Color - Resin Black, Natural
 Durability (mating cycles max) 250
 First Mate / Last Break No
 Flammability 94V-0
 Guide to Mating Part Yes
 Keying to Mating Part Yes
 Material - Metal Phosphor Bronze, Stainless Steel
 Material - Plating Mating Gold
 Material - Plating Termination Tin
 Material - Resin High Temperature Thermoplastic
 Number of Columns 12
 Number of Pairs Open Pin Field
 Number of Rows 6
 Orientation Vertical
 PC Tail Length (in) 0.138 In
 PC Tail Length (mm) 3.50 mm
 PCB Locator Yes
 PCB Retention None
 PCB Thickness Recommended (in) 0.098 In
 PCB Thickness Recommended (mm) 2.50 mm
 Packaging Type Tube
 Pitch - Mating Interface (in) 0.079 In
 Pitch - Mating Interface (mm) 2.00 mm
 Pitch - Term. Interface (in) 0.079 In
 Pitch - Term. Interface (mm) 2.00 mm
 Plating min: Mating (µin) 30
 Plating min: Mating (µm) 0.75
 Plating min: Termination (µin) 100
 Plating min: Termination (µm) 2.5
 Polarized to PCB No

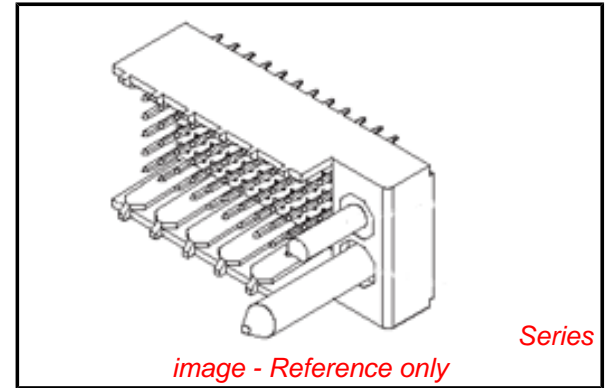

EU RoHS

**ELV and RoHS
 Compliant
 REACH SVHC
 Not Reviewed
 Halogen-Free
 Status
 Not Reviewed**

China RoHS



Need more information on product environmental compliance?

Email productcompliance@molex.com
 For a multiple part number RoHS Certificate of Compliance, [click here](#)

Please visit the [Contact Us](#) section for any non-product compliance questions.

Search Parts in this Series

[73944Series](#)

Mates With

[73632 HDM PLUS® Board-to-Board Daughtercard Receptacle](#). [73780 HDM® Board-to-Board Daughtercard Receptacle](#)

Application Tooling | FAQ

Tooling specifications and manuals are found by selecting the products below. Crimp Height Specifications are then contained in the Application Tooling Specification document.

Global

Description	Product #
HDM® Backplane	0621001400
Insertion Signal	
Contact Tool	
Extraction Tool	0621001000

Stackable	No
Surface Mount Compatible (SMC)	No
Temperature Range - Operating	-55°C to +105°C
Termination Interface: Style	Through Hole

Electrical

Current - Maximum per Contact	1A
Data Rate	1.0 Gbps
Shielded	No
Voltage - Maximum	250V AC

Material Info

Reference - Drawing Numbers

Packaging Specification	PK-70873-0818
Product Specification	PS-73670-9999
Sales Drawing	SD-73944-001

HDM and High Density Metric are trademarks of Amphenol Corporation

This document was generated on 05/14/2010

PLEASE CHECK WWW.MOLEX.COM FOR LATEST PART INFORMATION

NOTES:

1. MATERIALS: HOUSING--LIQUID CRYSTAL POLYMER (LCP), GLASS FILLED, UL94V-0, COLOR: BLACK,
TERMINAL: PHOSPHOR BRONZE.
2. FINISH: 0.75 MICROMETERS MINIMUM SELECTIVE GOLD (Au) IN MATING AREA
2.50 MICROMETERS MINIMUM SELECTIVE TIN (Sn) IN TAIL AREA
NICKEL (Ni) UNDERPLATE OVERALL.
3. THIS PART CONFORMS TO MOLEX PRODUCT SPECIFICATION PS-73670-9999.
4. FOR MIXED CONTACT MATING LENGTHS, CONSULT FACTORY FOR AVAILABILITY.
5. SEE SHEET 2 FOR SPECIFIC MATERIAL NUMBERS.
6. PACKAGE PER PK-70873-0818.
7. PARTS MARKED WITH PART NUMBER AND DATE CODE, ON EITHER SIDE, APPROXIMATELY WHERE SHOWN.

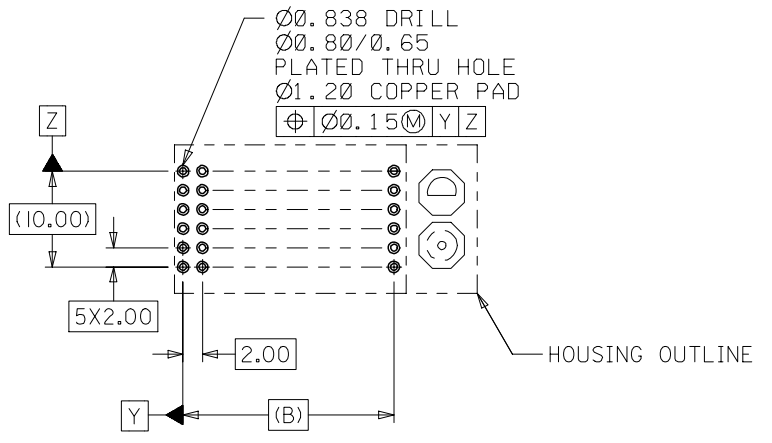
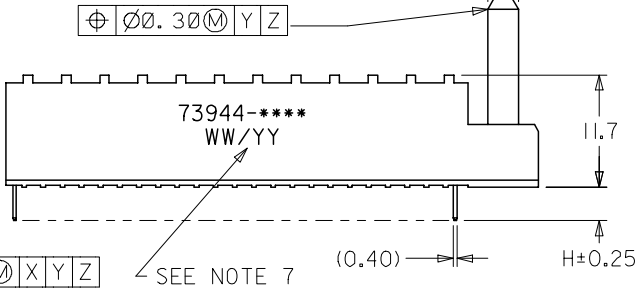
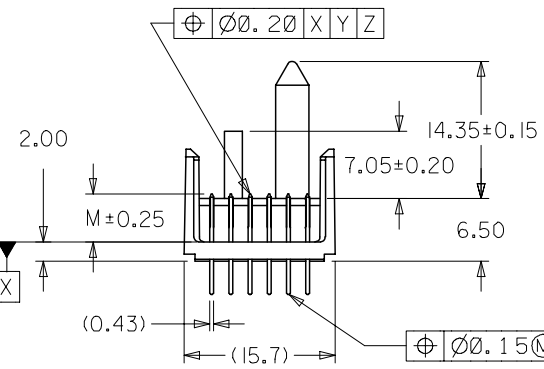

PCB LAYOUT: COMPONENT SIDE
RECOMMENDED PCB THICKNESS: 2.50 MIN

2	A
1	G
SHT	REV

MODIFY FINISH NOTE EC NO: UCP2007-2259 DRWN:MSIBARRA 2007/03/13 CHKD:BBARKER 2007/03/21 APPR:SMILLER 2007/03/22	QUALITY SYMBOLS	GENERAL TOLERANCES (UNLESS SPECIFIED)	DIMENSION STYLE	SCALE	DESIGN UNITS	THIRD ANGLE PROJECTION															
	▽=0 ▽=0	<table border="1"> <thead> <tr> <th></th> <th>mm</th> <th>INCH</th> </tr> </thead> <tbody> <tr> <td>4 PLACES</td> <td>± ---</td> <td>± ---</td> </tr> <tr> <td>3 PLACES</td> <td>± ---</td> <td>± ---</td> </tr> <tr> <td>2 PLACES</td> <td>± 0.05</td> <td>± ---</td> </tr> <tr> <td>1 PLACE</td> <td>± 0.10</td> <td>± ---</td> </tr> </tbody> </table> ANGULAR ±1/2°		mm	INCH	4 PLACES	± ---	± ---	3 PLACES	± ---	± ---	2 PLACES	± 0.05	± ---	1 PLACE	± 0.10	± ---	MM ONLY DRAWN BY: JB INGHAM DATE: 1998/01/14 CHECKED BY: SREED DATE: 1998/01/14 APPROVED BY: CBIXLER DATE: 1998/01/14	2:1	METRIC	TITLE: SALES ASSY HDM BACKPLANE POLAR/GUIDE OPTION SOLDER TAIL VERSION
		mm	INCH																		
	4 PLACES	± ---	± ---																		
3 PLACES	± ---	± ---																			
2 PLACES	± 0.05	± ---																			
1 PLACE	± 0.10	± ---																			
DRAFT WHERE APPLICABLE MUST REMAIN WITHIN DIMENSIONS	MATERIAL NO. SEE CHART	DOCUMENT NO. SD-73944-001	MOLEX INCORPORATED	SHEET NO. 1 OF 2																	
SIZE B	THIS DRAWING CONTAINS INFORMATION THAT IS PROPRIETARY TO MOLEX INCORPORATED AND SHOULD NOT BE USED WITHOUT WRITTEN PERMISSION																				

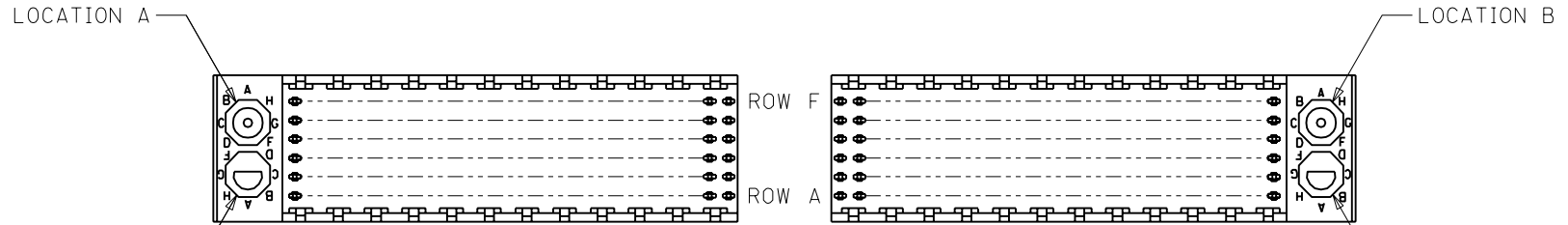

REF. MATERIAL NUMBER 73944-1009
GUIDE PIN IS IN LOCATION A
POLARIZING KEY IS IN LOCATION B, POSITION E

REF. MATERIAL NUMBER 73944-1008
GUIDE PIN IS IN LOCATION B
POLARIZING KEY IS IN LOCATION A, POSITION E

MATERIAL NUMBER ASSIGNMENT

73944- * * * *

NUMBER	CIRCUIT SIZE	DIM "A"	DIM "B"	DIM "H"
0	72	31.60	22.00	2.00
1	144	55.60	46.00	2.00
2	72	31.60	22.00	2.50
3	144	55.60	46.00	2.50
4	72	31.60	22.00	3.00
5	144	55.60	46.00	3.00
6	72	31.60	22.00	3.50
7	144	55.60	46.00	3.50

NUMBER	DIM "M"
0	5.00
1	5.50
2	6.00

NUMBER	GUIDE POST LOCATION	POLAR KEY POSITION
00	B	
01	A	A
02	B	B
03	A	C
04	B	D
05	A	E
06	B	F
07	A	G
08	B	H
09	A	
10	B	
11	A	
12	B	
13	A	
14	B	
15	A	
16	B	
17	A	
18	N/A	N/A

SEE SHEET 1
EC No. U81577
DRWN: BINGHAM 98/02/03
CHK: REED 98/02/03
APPR: BIXLER 98/02/03

DESCRIPTION
A

REV

QUALITY SYMBOLS
MAJOR $\blacktriangledown = 0$
CRITICAL $\nabla = 0$

GENERAL TOLERANCES: (UNLESS SPECIFIED)

	mm	INCH
4 PLACES	$\pm 0.$	$\pm .$
3 PLACES	$\pm 0.$	$\pm .$
2 PLACES	$\pm 0.N/A$	$\pm .$
1 PLACE	$\pm 0.N/A$	$\pm .$

ANGULAR: $\pm 1/2^\circ$

DRAFT WHERE APPLICABLE MUST REMAIN WITHIN DIMENSIONS

SCALE 2 : 1
DESIGN UNITS mm INCH

THIRD ANGLE PROJECTION mm INCH mm ONLY

DRAWN BY & DATE
JBINGHAM 98/01/14

CHECKED BY & DATE
SREED 98/01/14

APPROVED BY & DATE
CBIXLER 98/01/14

CAD FILENAME
S73944X2.DGN

DIMENSIONS:
 mm INCH mm ONLY

SHT REV
REVISE ON CAD ONLY

TITLE: SALES ASSY, HDM BACKPLANE
POLAR/GUIDE OPTION
SOLDER TAIL VERSION

MOLEX INCORPORATED

MATERIAL NO. SEE CHART
DRAWING NO. SD-73944-001
SHEET NO. 2

THIS DRAWING CONTAINS INFORMATION THAT IS PROPRIETARY TO MOLEX INCORPORATED AND SHOULD NOT BE USED WITHOUT WRITTEN PERMISSION.

SIZE B



**Стандарт
Электрон
Связь**

Мы молодая и активно развивающаяся компания в области поставок электронных компонентов. Мы поставляем электронные компоненты отечественного и импортного производства напрямую от производителей и с крупнейших складов мира.

Благодаря сотрудничеству с мировыми поставщиками мы осуществляем комплексные и плановые поставки широчайшего спектра электронных компонентов.

Собственная эффективная логистика и склад в обеспечивает надежную поставку продукции в точно указанные сроки по всей России.

Мы осуществляем техническую поддержку нашим клиентам и предпродажную проверку качества продукции. На все поставляемые продукты мы предоставляем гарантию .

Осуществляем поставки продукции под контролем ВП МО РФ на предприятия военно-промышленного комплекса России , а также работаем в рамках 275 ФЗ с открытием отдельных счетов в уполномоченном банке. Система менеджмента качества компании соответствует требованиям ГОСТ ISO 9001.

Минимальные сроки поставки, гибкие цены, неограниченный ассортимент и индивидуальный подход к клиентам являются основой для выстраивания долгосрочного и эффективного сотрудничества с предприятиями радиоэлектронной промышленности, предприятиями ВПК и научно-исследовательскими институтами России.

С нами вы становитесь еще успешнее!

Наши контакты:

Телефон: +7 812 627 14 35

Электронная почта: sales@st-electron.ru

Адрес: 198099, Санкт-Петербург,
Промышленная ул, дом № 19, литера Н,
помещение 100-Н Офис 331