

# EiceDRIVER™ 1EDI Compact

Single channel IGBT gate driver IC with clamp in wide body package

## Features

- Single channel isolated gate driver
- For 600 V/650 V/1200 V IGBTs, MOSFETs, and SiC MOSFETs
- Up to 6 A typical peak current at rail-to-rail output
- Active Miller clamp
- Galvanically isolated coreless transformer driver
- Wide input voltage operating range
- Suitable for operation at high ambient temperature and in fast switching applications

## Potential applications

- AC and brushless DC motor drives
- High voltage DC/DC-converter and DC/AC-inverter
- Induction heating resonant application
- UPS-systems
- Welding
- Solar



Product type	Minimum output current and configuration	Package
1EDI10I12MH	±1.0 A with 1.0 A Miller clamp	PG-DSO-8-59
1EDI20I12MH	±2.0 A with 2.0 A Miller clamp	PG-DSO-8-59
1EDI30I12MH	±3.0 A with 3.0 A Miller clamp	PG-DSO-8-59

## Product validation

Qualified for industrial applications according to the relevant tests of JEDEC47/20/22.

**Description**

**Description**

The 1EDIxxI12MH are galvanically isolated single channel IGBT driver in a PG-DSO-8-59 package that provide output currents up to 3 A and an integrated active Miller clamp circuit with the same current rating to protect against parasitic turn on.

The input logic pins operate on a wide input voltage range from 3 V to 15 V using scaled CMOS threshold levels to support even 3.3 V microcontrollers.

Data transfer across the isolation barrier is realized by the coreless transformer technology.

Every driver family member comes with logic input and driver output undervoltage lockout (UVLO) and active shutdown.

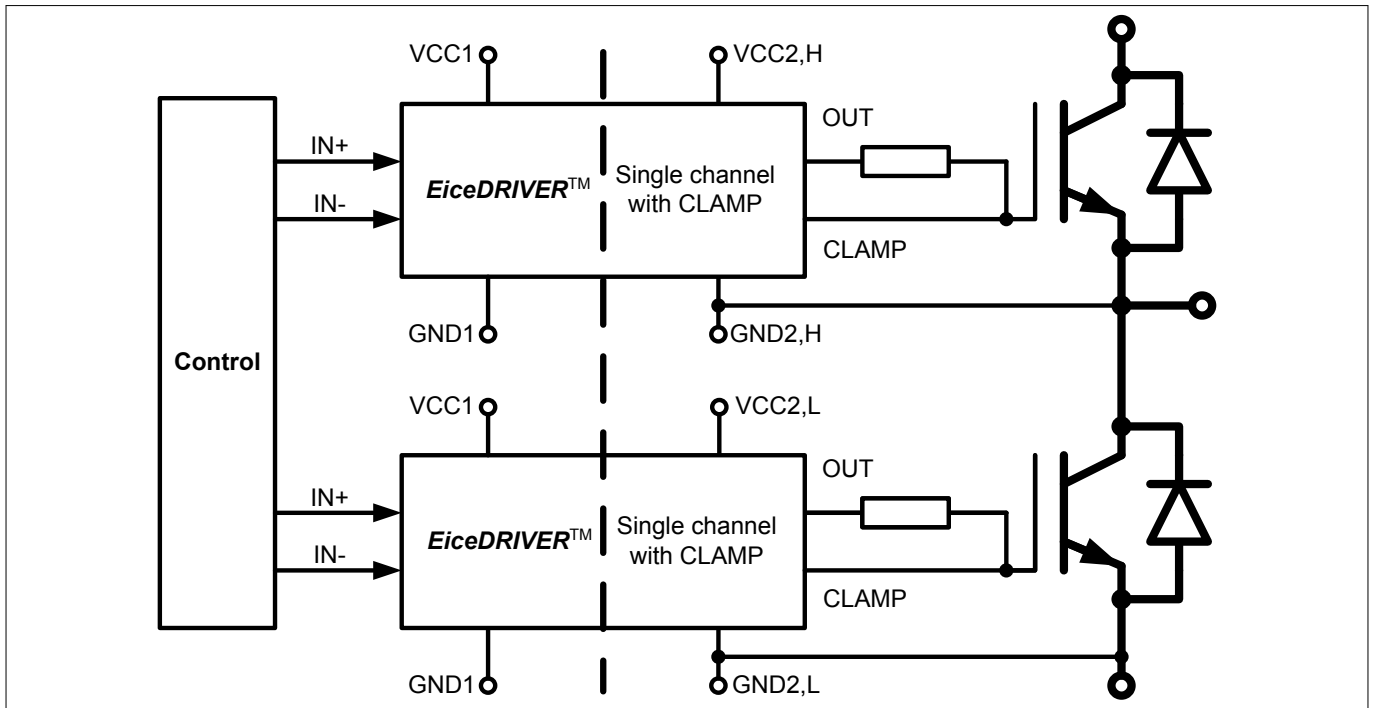

**Figure 1 Typical application**

**Table of contents**

**Table of contents**

	<b>Table of contents</b> .....	3
<b>1</b>	<b>Block diagram</b> .....	4
<b>2</b>	<b>Pin configuration and functionality</b> .....	5
2.1	Pin configuration .....	5
2.2	Pin functionality .....	5
<b>3</b>	<b>Functional description</b> .....	7
3.1	Supply .....	7
3.2	Protection features .....	8
3.2.1	Undervoltage lockout (UVLO) .....	8
3.2.2	Active shut-down .....	8
3.2.3	Short circuit clamping .....	8
3.2.4	Active Miller clamp .....	8
3.3	Non-inverting and inverting inputs .....	9
3.4	Driver output .....	9
<b>4</b>	<b>Electrical parameters</b> .....	10
4.1	Absolute maximum ratings .....	10
4.2	Operating parameters .....	11
4.3	Electrical characteristics .....	11
4.3.1	Voltage supply .....	11
4.3.2	Logic input .....	12
4.3.3	Gate driver .....	13
4.3.4	Short circuit clamping .....	14
4.3.5	Active Miller clamp .....	14
4.3.6	Dynamic characteristics .....	15
4.3.7	Active shut down .....	15
<b>5</b>	<b>Package outline</b> .....	16
<b>6</b>	<b>Application notes</b> .....	17
6.1	Reference layout for thermal data .....	17
6.2	Printed circuit board guidelines .....	17
	<b>Revision history</b> .....	17
	<b>Trademarks</b> .....	18

**Block diagram**

**1 Block diagram**



**Figure 2 Block diagram**

**Pin configuration and functionality**

**2 Pin configuration and functionality**

**2.1 Pin configuration**

**Table 1 Pin configuration**

Pin No.	Name	Function
1	VCC1	Positive logic supply
2	IN+	Non-inverted driver input (active high)
3	IN-	Inverted driver input (active low)
4	GND1	Logic ground
5	GND2	Power ground
6	VCC2	Positive power supply voltage
7	OUT	Driver output
8	CLAMP	Active Miller clamp



**Figure 3 PG-DSO-8-59 (top view)**

**2.2 Pin functionality**

**VCC1**

Logic input supply voltage of 3.3 V up to 15 V wide operating range.

**IN+ non inverting driver input**

IN+ non-inverted control signal for driver output if IN- is set to low. (Output sourcing active at IN+ = high and IN- = low)

Due to internal filtering a minimum pulse width is defined to ensure robustness against noise at IN+. An internal weak pull-down-resistor favors off-state.

**IN- inverting driver input**

IN- inverted control signal for driver output if IN+ is set to high. (Output sourcing active at IN- = low and IN+ = high)

Due to internal filtering a minimum pulse width is defined to ensure robustness against noise at IN-. An internal weak pull-up-resistor favors off-state.

## Pin configuration and functionality

### ***GND1***

Ground connection of input circuit.

### ***GND2 reference ground***

Reference ground of the output driving circuit.

### ***VCC2***

Positive power supply pin of output driving circuit. A proper blocking capacitor has to be placed close to this supply pin.

### ***OUT driver output***

Combined source and sink output pin to external IGBT. The output voltage will be switched between *VCC2* and *GND2* and is controlled by *IN+* and *IN-*. In case of an UVLO event this output will be switched off and an active shut down keeps the output voltage at a low level.

### ***CLAMP active Miller clamp***

Connect gate of external IGBT directly to this pin. As soon as the gate voltage has dropped below 2 V referred to *GND2* during turn off state the Miller clamp function ties its output to *GND2* to avoid parasitic turn on of the connected IGBT.

**Functional description**

### 3 Functional description

The 1EDIxxl12MH is a general purpose IGBT gate driver. Basic control and protection features support fast and easy design of highly reliable systems.

The integrated galvanic isolation between control input logic and driving output stage grants additional safety. Its wide input voltage supply range supports the direct connection of various signal sources like DSPs and microcontrollers.

With the rail-to-rail output and the additional active Miller clamp, dynamic turn on due to Miller capacitance is suppressed.

#### 3.1 Supply

The driver can operate over a wide supply voltage range.



**Figure 4 Application example**

The typical positive supply voltage for the driver is 15 V at VCC2. Erratical dynamic turn on of the IGBT can be prevented with the active Miller clamp function, in which the CLAMP output is directly connected to the IGBT gate.

**Functional description**

**3.2 Protection features**

**3.2.1 Undervoltage lockout (UVLO)**



**Figure 5 UVLO behavior**

To ensure correct switching of IGBTs the device is equipped with an undervoltage lockout for input and output independently. Operation starts only after both VCC levels have increased beyond the respective  $V_{UVLOH}$  levels

If the power supply voltage  $V_{VCC1}$  of the input chip drops below  $V_{UVLOL1}$  a turn-off signal is sent to the output chip before power-down. The IGBT is switched off and the signals at *IN+* and *IN-* are ignored until  $V_{VCC1}$  reaches the power-up voltage  $V_{UVLOH1}$  again.

If the power supply voltage  $V_{VCC2}$  of the output chip goes down below  $V_{UVLOL2}$  the IGBT is switched off and signals from the input chip are ignored until  $V_{VCC2}$  reaches the power-up voltage  $V_{UVLOH2}$  again.

**3.2.2 Active shut-down**

The active shut-down feature ensures a safe IGBT off-state if the output chip is not connected to the power supply or an undervoltage lockout is in effect. The IGBT gate is clamped at *OUT* to *GND2*.

**3.2.3 Short circuit clamping**

During short circuit the IGBT's gate voltage tends to rise because of the feedback via the Miller capacitance. An additional protection circuit connected to *OUT* and *CLAMP* limits this voltage to a value slightly higher than the supply voltage. A maximum current of 500 mA may be fed back to the supply through one of these paths for 10  $\mu$ s. If higher currents are expected or tighter clamping is desired external Schottky diodes may be added.

**3.2.4 Active Miller clamp**

In a half bridge configuration the switched off IGBT tends to dynamically turn on during turn on phase of the opposite IGBT. A Miller clamp allows sinking the Miller current across a low impedance path in this high  $dV/dt$  situation. Therefore in many applications, the use of a negative supply voltage can be avoided. During turn-off, the gate voltage is monitored and the clamp output is activated when the gate voltage drops below typical 2 V (referred to *GND2*). The clamp is designed for a Miller current in the same range as the nominal output current.



---

**Functional description**

### 3.3 Non-inverting and inverting inputs

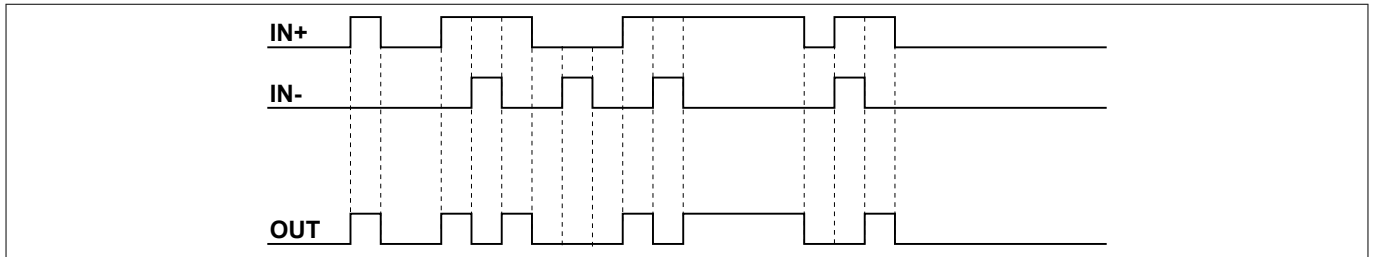

**Figure 6** Logic input to output switching behavior

There are two possible input modes to control the IGBT. At non-inverting mode *IN+* controls the driver output while *IN-* is set to low. At inverting mode *IN-* controls the driver output while *IN+* is set to high. A minimum input pulse width is defined to filter occasional glitches.

### 3.4 Driver output

The output driver section uses MOSFETs to provide a rail-to-rail output. This feature permits that tight control of gate voltage during on-state and short circuit can be maintained as long as the driver's supply is stable. Due to the low internal voltage drop, switching behavior of the IGBT is predominantly governed by the gate resistor. Furthermore, it reduces the power to be dissipated by the driver.

**Electrical parameters**

## 4 Electrical parameters

### 4.1 Absolute maximum ratings

Note: Absolute maximum ratings are defined as ratings, which when being exceeded may lead to destruction of the integrated circuit. Unless otherwise noted all parameters refer to GND1

**Table 2 Absolute maximum ratings**

Parameter	Symbol	Values		Unit	Note or Test Condition
		Min.	Max.		
Power supply output side	$V_{VCC2}$	-0.3	20 <sup>1)</sup>	V	2)
Gate driver output	$V_{OUT}$	$V_{GND2}-0.3$	$V_{VCC2}+0.3$	V	2)
Maximum short circuit clamping time	$t_{CLP}$	–	10	μs	$I_{CLAMP/OUT} = 500 \text{ mA}$
Positive power supply input side	$V_{VCC1}$	-0.3	18.0	V	–
Logic input voltages (IN+,IN-)	$V_{LogicIN}$	-0.3	18.0	V	–
Pin CLAMP voltage	$V_{CLAMP}$	-0.3	$V_{VCC2}+0.3$ <sup>1)</sup>	V	2)
Input to output isolation voltage (GND2)	$V_{GND2}$	-1200	1200	V	GND2 - GND1
Junction temperature	$T_J$	-40	150	°C	–
Storage temperature	$T_S$	-55	150	°C	–
Comparative tracking index	CTI	400	–		IEC 60601-1: Material group II
Power dissipation (Input side)	$P_{D, IN}$	–	25	mW	3) @ $T_A = 25^\circ\text{C}$
Power dissipation (Output side)	$P_{D, OUT}$	–	400	mW	3) @ $T_A = 25^\circ\text{C}$
Thermal resistance (Input side)	$R_{THJA, IN}$	–	145	K/W	3) @ $T_A = 85^\circ\text{C}$
Thermal resistance (Output side)	$R_{THJA, OUT}$	–	165	K/W	3) @ $T_A = 85^\circ\text{C}$
ESD capability	$V_{ESD, HBM}$	–	2	kV	Human body model <sup>4)</sup>
	$V_{ESD, CDM}$	–	1	kV	Charged device model <sup>5)</sup>

<sup>1</sup> May be exceeded during short circuit clamping.

<sup>2</sup> With respect to GND2.

<sup>3</sup> See **Figure 10** for reference layouts for these thermal data. Thermal performance may change significantly with layout and heat dissipation of components in close proximity.

<sup>4</sup> According to EIA/JESD22-A114-C (discharging a 100 pF capacitor through a 1.5 kΩ series resistor).

<sup>5</sup> According to EIA/JESD22-C101 (specified waveform characteristics)

**Electrical parameters**

**4.2 Operating parameters**

Note: Within the operating range the IC operates as described in the functional description. Unless otherwise noted all parameters refer to GND1.

**Table 3 Operating parameters**

Parameter	Symbol	Values		Unit	Note or Test Condition
		Min.	Max.		
Power supply output side	$V_{VCC2}$	13	18	V	6)
Power supply input side	$V_{VCC1}$	3.1	17	V	–
Logic input voltages (IN+,IN-)	$V_{LogicIN}$	-0.3	17	V	–
Pin CLAMP voltage	$V_{CLAMP}$	$V_{GND2}-0.3$	$V_{VCC2}$ <sup>7)</sup>	V	6)
Switching frequency	$f_{sw}$	–	1.0	MHz	8)9)
Ambient temperature	$T_A$	-40	125	°C	–
Thermal coefficient, junction-top	$\psi_{th,jt}$	–	4.8	K/W	9)@ $T_A = 85^\circ\text{C}$
Common mode transient immunity	$ dV_{ISO}/dt $	–	100	kV/ $\mu\text{s}$	9) @ 1000 V

**4.3 Electrical characteristics**

Note: The electrical characteristics include the spread of values in supply voltages, load and junction temperatures given below. Typical values represent the median values at  $T_A = 25^\circ\text{C}$ . Unless otherwise noted all voltages are given with respect to their respective GND (GND1 for pins 1 to 3, GND2 for pins 6 to 8).

**4.3.1 Voltage supply**

**Table 4 Voltage supply**

Parameter	Symbol	Values			Unit	Note or Test Condition
		Min.	Typ.	Max.		
UVLO threshold input chip	$V_{UVLOH1}$	–	2.85	3.1	V	–
	$V_{UVLOL1}$	2.55	2.75	–	V	–
UVLO hysteresis input chip ( $V_{UVLOH1} - V_{UVLOL1}$ )	$V_{HYS1}$	0.09	0.10	–	V	–

<sup>6</sup> With respect to GND2.

<sup>7</sup> May be exceeded during short circuit clamping.

<sup>8</sup> do not exceed max. power dissipation

<sup>9</sup> Parameter is not subject to production test - verified by design/characterization

**Electrical parameters**

**Table 4 Voltage supply (continued)**

Parameter	Symbol	Values			Unit	Note or Test Condition
		Min.	Typ.	Max.		
UVLO threshold output chip (IGBT supply)	$V_{UVLOH2}$	–	11.9	12.7	V	10)
	$V_{UVLOL2}$	10.5	11.0	–	V	10)
UVLO hysteresis output chip ( $V_{UVLOH1} - V_{UVLOL1}$ )	$V_{HYS2}$	0.7	0.85	–	V	–
Quiescent current input chip	$I_{Q1}$	–	0.6	1	mA	$V_{VCC1} = 5\text{ V}$ $IN+ = \text{High}, IN- = \text{Low}$ $\Rightarrow OUT = \text{High}$
Quiescent current output chip	$I_{Q2}$	–	1.2	2	mA	$V_{VCC2} = 15\text{ V}$ $IN+ = \text{High}, IN- = \text{Low}$ $\Rightarrow OUT = \text{High}$

**4.3.2 Logic input**



**Figure 7  $V_{CC1}$  scaled input threshold voltage of  $IN+$  and  $IN-$**

Beginning from the input undervoltage lockout level, threshold levels for  $IN+$  and  $IN-$  are scaled to  $V_{CC1}$ . The high input threshold is 70% of  $V_{CC1}$  and the low input threshold is at 30% of  $V_{CC1}$ .

<sup>10</sup> With respect to  $GND2$ .

**Electrical parameters**

**Table 5 Logic input**

Parameter	Symbol	Values			Unit	Note or Test Condition
		Min.	Typ.	Max.		
$I_{N+}, I_{N-}$ low input voltage	$V_{IN+L},$ $V_{IN-L}$	–	–	$0.3 \times V_{VCC1}$		<sup>11)</sup> $3.1 \text{ V} \leq V_{VCC1} \leq 17 \text{ V}$
$I_{N+}, I_{N-}$ high input voltage	$V_{IN+H},$ $V_{IN-H}$	$0.7 \times V_{VCC1}$	–	–		
$I_{N+}, I_{N-}$ low input voltage	$V_{IN+L},$ $V_{IN-L}$	–	–	1.5	V	$V_{VCC1} = 5.0 \text{ V}$
$I_{N+}, I_{N-}$ high input voltage	$V_{IN+H},$ $V_{IN-H}$	3.5	–	–	V	
$I_{N-}$ input current	$I_{IN-}$	–	70	200	$\mu\text{A}$	$V_{VCC1} = 5.0 \text{ V}, V_{IN-} = GND1$
$I_{N+}$ input current	$I_{IN+}$	–	70	200	$\mu\text{A}$	$V_{VCC1} = 5.0 \text{ V}, V_{IN+} = V_{VCC1}$

**4.3.3 Gate driver**

Note: minimum Peak current rating valid over temperature range!

**Table 6 Gate driver**

Parameter	Symbol	Values			Unit	Note or Test Condition
		Min.	Typ.	Max.		
High level output peak current (source)	$I_{OUT,H,PEAK}$			–	A	<sup>12)</sup> $I_{N+} = \text{High},$ $I_{N-} = \text{Low},$ $V_{VCC2} = 15 \text{ V}$
1EDI10I12MH		1.0	2.2			
1EDI20I12MH		2.0	4.4			
1EDI30I12MH		3.0	5.9			
Low level output peak current (sink)	$I_{OUT,L,PEAK}$			–	A	<sup>12)</sup> $I_{N+} = \text{Low},$ $I_{N-} = \text{Low},$ $V_{VCC2} = 15 \text{ V}$
1EDI10I12MH		1.0	2.3			
1EDI20I12MH		2.0	4.1			
1EDI30I12MH		3.0	6.2			

<sup>11</sup> Parameter is not subject to production test - verified by design/characterization

<sup>12</sup> specified min. output current is forced; voltage across the device  $V_{(VCC2 - OUT)}$  or  $V_{(OUT - GND2)} < V_{VCC2}$ .

**Electrical parameters**

**4.3.4 Short circuit clamping**

**Table 7 Short circuit clamping**

Parameter	Symbol	Values			Unit	Note or Test Condition
		Min.	Typ.	Max.		
Clamping voltage (OUT) ( $V_{OUT} - V_{VCC2}$ )	$V_{CLPout}$	–	0.9	1.3	V	<sup>13)</sup> $I_{N+} = \text{High}$ , $I_{N-} = \text{Low}$ , $I_{OUT} = 500 \text{ mA}$ (pulse test $t_{CLPmax} = 10 \mu\text{s}$ )
Clamping voltage (CLAMP) ( $V_{VCLAMP} - V_{VCC2}$ )	$V_{CLPclamp1}$	–	1.3	–	V	<sup>13)</sup> $I_{N+} = \text{High}$ , $I_{N-} = \text{Low}$ , $I_{CLAMP} = 500 \text{ mA}$ (pulse test $t_{CLPmax} = 10 \mu\text{s}$ )
Clamping voltage (CLAMP)	$V_{CLPclamp2}$	–	0.7	1.1	V	<sup>13)</sup> $I_{N+} = \text{High}$ , $I_{N-} = \text{Low}$ , $I_{CLAMP} = 20 \text{ mA}$

**4.3.5 Active Miller clamp**

**Table 8 Active Miller clamp**

Parameter	Symbol	Values			Unit	Note or Test Condition
		Min.	Typ.	Max.		
Low level clamp current 1EDI10I12MH 1EDI20I12MH 1EDI30I12MH	$I_{CLAMP,PEAK}$	1.0 2.0 3.0	–	–	A	<sup>14)</sup> $I_{N+} = \text{Low}$ , $I_{N-} = \text{Low}$ , $V_{CLAMP} = 15 \text{ V}$ pulsed $t_{pulse} = 2 \mu\text{s}$
Clamp threshold voltage	$V_{CLAMP}$	1.6	2.0	2.4	V	<sup>15)</sup>

<sup>13)</sup> With respect to *GND2*.

<sup>14)</sup> Parameter is not subject to production test - verified by design/characterization

<sup>15)</sup> With respect to *GND2*.

**Electrical parameters**

**4.3.6 Dynamic characteristics**

Dynamic characteristics are measured with  $V_{VCC1} = 5\text{ V}$  and  $V_{VCC2} = 15\text{ V}$ .

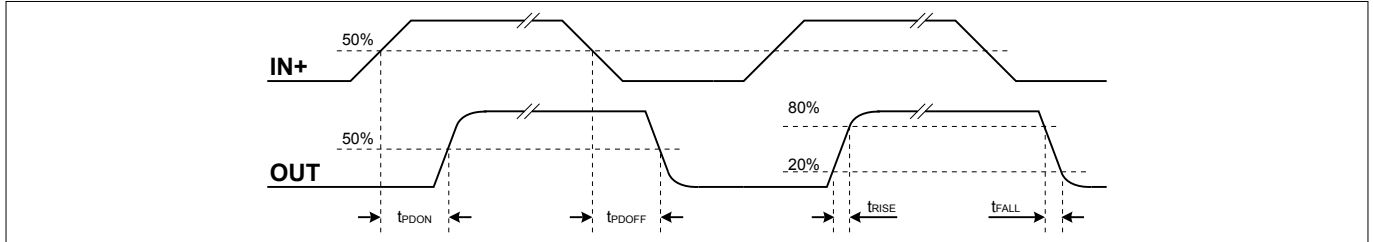

**Figure 8 Propagation delay, rise and fall time**

**Table 9 Dynamic characteristics**

Parameter	Symbol	Values			Unit	Note or Test Condition
		Min.	Typ.	Max.		
Input IN to output propagation delay ON	$t_{PDON}$	270	300	330	ns	$C_{LOAD} = 100\text{ pF}$ $V_{IN+} = 50\%$ , $V_{OUT} = 50\%$ @ 25°C
Input IN to output propagation delay OFF	$t_{PDOFF}$	270	300	330	ns	
Input IN to output propagation delay distortion ( $t_{PDOFF} - t_{PDON}$ )	$t_{PDISTO}$	-30	5	40	ns	
Input pulse suppression time $IN+$ , $IN-$	$t_{MININ+}$ , $t_{MININ-}$	230	240	-	ns	
IN input to output propagation delay ON variation due to temp	$t_{PDONT}$	-	-	14	ns	<sup>16)</sup> $C_{LOAD} = 100\text{ pF}$ $V_{IN+} = 50\%$ , $V_{OUT} = 50\%$
IN input to output propagation delay OFF variation due to temp	$t_{PDOFFt}$	-	-	14	ns	
IN input to output propagation delay distortion variation due to temp ( $t_{PDOFF} - t_{PDON}$ )	$t_{PDISTOt}$	-	-	8	ns	
Rise time	$t_{RISE}$	5	10	20	ns	$C_{LOAD} = 1\text{ nF}$
Fall time	$t_{FALL}$	3	9	19	ns	$V_L 20\%$ , $V_H 80\%$

**4.3.7 Active shut down**

**Table 10 Active shut down**

Parameter	Symbol	Values			Unit	Note or Test Condition
		Min.	Typ.	Max.		
Active shut down voltage	$V_{ACTSD}$	-	2.0	2.3	V	<sup>17)</sup> $I_{OUT-}/I_{OUT-,PEAK} = 0.1$ , $V_{CC2}$ open

<sup>16</sup> Parameter is not subject to production test - verified by design/characterization

<sup>17</sup> With respect to  $GND2$ .

**Package outline**

**5 Package outline**



**Figure 9 PG-DSO-8-59 (Plastic (green) dual small outline package)**



**Application notes**

**6 Application notes**

**6.1 Reference layout for thermal data**



**Figure 10 Reference layout for thermal data (Copper thickness 35 μm)**

This PCB layout represents the reference layout used for the thermal characterization.

Pin 4 (*GND1*) and pin 5 (*GND2*) require each a ground plane of 100 mm<sup>2</sup> for achieving maximum power dissipation. The package is built to dissipate most of the heat generated through these pins.

The thermal coefficient junction-top ( $\Psi_{th,jt}$ ) can be used to calculate the junction temperature at a given top case temperature and driver power dissipation:

$$T_j = \Psi_{th,jt} \cdot P_D + T_{top}$$

**6.2 Printed circuit board guidelines**

The following factors should be taken into account for an optimum PCB layout.

- Sufficient spacing should be kept between high voltage isolated side and low voltage side circuits.
- The same minimum distance between two adjacent high-side isolated parts of the PCB should be maintained to increase the effective isolation and to reduce parasitic coupling.
- In order to ensure low supply ripple and clean switching signals, bypass capacitor trace lengths should be kept as short as possible.

**Revision history**

Document version	Date of release	Description of changes
2.1	2017-09-04	Increase of typical gate driver output current values; formatting updated for electrical parameters and pins
2.0	2016-07-05	Extended description of VCC1 scaled input thresholds
1.0	2016-04-14	Missing electrical product parameters updated

## Trademarks

All referenced product or service names and trademarks are the property of their respective owners.

**Edition 2017-09-04**

**Published by  
Infineon Technologies AG  
81726 Munich, Germany**

**© 2017 Infineon Technologies AG  
All Rights Reserved.**

**Do you have a question about any  
aspect of this document?  
Email: [erratum@infineon.com](mailto:erratum@infineon.com)**

**Document reference  
IFX-sch1433998947775**

## IMPORTANT NOTICE

The information given in this document shall in no event be regarded as a guarantee of conditions or characteristics ("Beschaffheitsgarantie").

With respect to any examples, hints or any typical values stated herein and/or any information regarding the application of the product, Infineon Technologies hereby disclaims any and all warranties and liabilities of any kind, including without limitation warranties of non-infringement of intellectual property rights of any third party.

In addition, any information given in this document is subject to customer's compliance with its obligations stated in this document and any applicable legal requirements, norms and standards concerning customer's products and any use of the product of Infineon Technologies in customer's applications.

The data contained in this document is exclusively intended for technically trained staff. It is the responsibility of customer's technical departments to evaluate the suitability of the product for the intended application and the completeness of the product information given in this document with respect to such application.

## WARNINGS

Due to technical requirements products may contain dangerous substances. For information on the types in question please contact your nearest Infineon Technologies office.

Except as otherwise explicitly approved by Infineon Technologies in a written document signed by authorized representatives of Infineon Technologies, Infineon Technologies' products may not be used in any applications where a failure of the product or any consequences of the use thereof can reasonably be expected to result in personal injury



## Стандарт Электрон Связь

Мы молодая и активно развивающаяся компания в области поставок электронных компонентов. Мы поставляем электронные компоненты отечественного и импортного производства напрямую от производителей и с крупнейших складов мира.

Благодаря сотрудничеству с мировыми поставщиками мы осуществляем комплексные и плановые поставки широчайшего спектра электронных компонентов.

Собственная эффективная логистика и склад в обеспечивает надежную поставку продукции в точно указанные сроки по всей России.

Мы осуществляем техническую поддержку нашим клиентам и предпродажную проверку качества продукции. На все поставляемые продукты мы предоставляем гарантию .

Осуществляем поставки продукции под контролем ВП МО РФ на предприятия военно-промышленного комплекса России , а также работаем в рамках 275 ФЗ с открытием отдельных счетов в уполномоченном банке. Система менеджмента качества компании соответствует требованиям ГОСТ ISO 9001.

Минимальные сроки поставки, гибкие цены, неограниченный ассортимент и индивидуальный подход к клиентам являются основой для выстраивания долгосрочного и эффективного сотрудничества с предприятиями радиоэлектронной промышленности, предприятиями ВПК и научно-исследовательскими институтами России.

С нами вы становитесь еще успешнее!

### Наши контакты:

**Телефон:** +7 812 627 14 35

**Электронная почта:** [sales@st-electron.ru](mailto:sales@st-electron.ru)

**Адрес:** 198099, Санкт-Петербург,  
Промышленная ул, дом № 19, литера Н,  
помещение 100-Н Офис 331