

AN-EVAL3GS03LJG

65W 19.5V SMPS Evaluation Board with
F3 PWM controller ICE3GS03LJG

Power Management & Supply



N e v e r s t o p t h i n k i n g .

Published by
Infineon Technologies AG
81726 Munich, Germany
© 2011 Infineon Technologies AG
All Rights Reserved.

Legal Disclaimer

The information given in this document shall in no event be regarded as a guarantee of conditions or characteristics. With respect to any examples or hints given herein, any typical values stated herein and/or any information regarding the application of the device, Infineon Technologies hereby disclaims any and all warranties and liabilities of any kind, including without limitation, warranties of non-infringement of intellectual property rights of any third party.

Information

For further information on technology, delivery terms and conditions and prices, please contact the nearest Infineon Technologies Office (www.infineon.com).

Warnings

Due to technical requirements, components may contain dangerous substances. For information on the types in question, please contact the nearest Infineon Technologies Office.

Infineon Technologies components may be used in life-support devices or systems only with the express written approval of Infineon Technologies, if a failure of such components can reasonably be expected to cause the failure of that life-support device or system or to affect the safety or effectiveness of that device or system. Life support devices or systems are intended to be implanted in the human body or to support and/or maintain and sustain and/or protect human life. If they fail, it is reasonable to assume that the health of the user or other persons may be endangered.

Table of Contents		Page
1	Abstract.....	5
2	Evaluation Board.....	5
3	List of Features	6
4	Technical Specifications	6
5	Circuit Description	7
5.1	Introduction.....	7
5.2	Line Input.....	7
5.3	Start up.....	7
5.4	Operation mode	7
5.5	Soft start.....	7
5.6	RCD Clamper circuit	7
5.7	Main switcher	7
5.8	Gate drive.....	7
5.9	Peak current control of primary current.....	8
5.10	Output Stage	8
5.11	Feedback and regulation.....	8
5.12	Blanking Window for Load Jump	8
5.13	Active Burst Mode	8
5.14	Jitter mode.....	9
5.15	Protection modes	9
6	Circuit Diagram	10
7	PCB Layout.....	12
7.1	Top side.....	12
7.2	Bottom side	12
8	Component List.....	13
9	Transformer Construction.....	14
10	Test results	15
10.1	Efficiency	15
10.2	Input standby power	16
10.3	Line regulation.....	17
10.4	Load regulation	17
10.5	Maximum input power	18
10.6	ESD test	18
10.7	Lightning surge test.....	18
10.8	Conducted EMI	19
11	Waveforms and scope plots	21
11.1	Start up at low and high AC line input voltage and maximum load.....	21
11.2	Soft start at low and high AC line input voltage and maximum load.....	21
11.3	Frequency jittering.....	22
11.4	Drain to source voltage and current @ maximum load.....	22
11.5	Load transient response (Dynamic load from 10% to 100%)	23
11.6	Output ripple voltage at maximum load	23
11.7	Output ripple voltage during burst mode at 1 W load	24
11.8	Entering active burst mode	24
11.9	V _{CC} overvoltage protection (Latch off)	25
11.10	External protection enable (Latch off)	25
11.11	Over load protection (built-in + extended blanking time) (Auto restart)	26
11.12	Open loop protection (Auto restart).....	26
11.13	V _{CC} under voltage/Short optocoupler protection (Auto restart).....	27
12	References	27

1 Abstract

This document is an engineering report that describes a universal input power supply designed in a 19.5V 65W off line flyback converter that utilizes the F3 PWM controller ICE3GS03LJG. The application board is operated in discontinuous current mode (DCM) and is running at 130 kHz switching frequency. It has one output voltage with secondary side control regulation. It is especially suitable for AC/DC power supply such as LCD monitors, adapters for printers and notebook computers, DVD players and recorder, Blue-Ray DVD player and recorder, set-top boxes and industrial auxiliary power supplies. The ICE3GS03LJG is a current mode PWM controller. With the 500V startup cell, active burst mode and BiCMOS technologies, the standby power can be <math><100\text{mW}</math> at no load. The frequency jitter mode and the soft gate drive can give a low EMI performance. The built-in 20ms blanking window and the extendable blanking time approach can prevent the IC from entering the auto restart mode due to over load protection unintentionally. The outstanding propagation delay compensation feature can allow a very precise current limit between low line and high line. For this IC, it provides both auto-restart and latch off protection mode. For those serious faults such as Vcc over-voltage, over temperature, short transformer winding, etc, the IC will enter the latched off protection mode. For those less severe case such as the over load, open loop, Vcc under-voltage & short opto-coupler, it enters the auto restart protection mode. In case it needs customer defined protection, the external latch off enable feature can fulfill the requirement.

2 Evaluation Board



Figure 1 – EVAL3GS03LJG

This document contains the list of features, the power supply specification, schematic, bill of material and the transformer construction drawing. Typical operating characteristics and performance curves with scope waveforms are presented at the rear of the report.

3 List of Features

500V Startup Cell switched off after Start Up
Active Burst Mode for lowest Standby Power
Fast load jump response in Active Burst Mode
130 kHz internally fixed switching frequency
Built-in Latched Off Protection Mode for Overtemperature, Overvoltage & Short Winding
Auto Restart Protection Mode for Overload, Open Loop, VCC Undervoltage & Short Optocoupler
Built-in Soft Start
Built-in blanking window with extendable blanking time for short duration high current
External latch off enable function
Max Duty Cycle 75%
Overall tolerance of Current Limiting < $\pm 5\%$
Internal PWM Leading Edge Blanking
BiCMOS technology provide wide VCC range
Frequency jitter and soft gate driving for low EMI

4 Technical Specifications

Input voltage	85VAC~265VAC
Input frequency	50Hz, 60Hz
Input Standby Power	< 100mV @ no load
Output voltage and current	19.5V +/- 2%
Output current	3.34A
Output power	65W
Average Efficiency	>82% (115Vac & 230Vac)
Output ripple voltage	< 100mVp-p

5 Circuit Description

5.1 Introduction

The EVAL3GS03LJG demo board is an off line flyback switch mode power supply (SMPS) using the ICE3GS03LJG PWM IC from the Infineon PWM (fixed frequency) controller. The circuit, shown in Figure 2, details a 19.5V, 65W power supply that operates from an AC line input voltage range of 85Vac to 265Vac, suitable for applications requiring either an open frame supply or an enclosed adapter.

5.2 Line Input

The AC input side comprises the input fuse F1 as over-current protection. The common mode choke L11 and L12, X-capacitors C11 and C14 and Y-capacitor C12 act as EMI suppressors. A varistor VAR (optional) is added to absorb the line transient while a NTC (optional) is added to reduce the inrush surge current during start up. A rectified DC voltage (120V ~ 375V) is obtained through the bridge rectifier BR1 and the input bulk capacitor C13.

5.3 Start up

Since there is a built-in startup cell in the ICE3GS03LJG, there is no need for external start up resistors. The startup cell is connecting the HV pin of the IC. Once the voltage is built up at the HV pin of the ICE3GS03LJG, the startup cell will charge up the Vcc capacitor C16 and C110. When the Vcc voltage exceeds the UVLO at 18V, the IC starts up. Then the Vcc voltage is bootstrapped by the auxiliary winding to sustain the operation.

5.4 Operation mode

During operation, the Vcc pin is supplied via a separate transformer winding with associated rectification D12 and buffering and filtering capacitors C16 and C110. Resistor R12 is used for current limiting. In order not to exceed the maximum voltage at Vcc pin, an external zener diode ZD11 (optional) and R13 (optional) is added to clamp the voltage.

5.5 Soft start

The Soft-Start time is built-in 10ms. After the Vcc hits UVLO at 18V, it starts the soft-start phase.

5.6 RCD Clamper circuit

While turning off the switch Q11, the clamper circuit R11, C15 and D11 absorbs the current caused by transformer leakage inductance once the voltage exceeds clamper circuit voltage. Then drain to source voltage is well below the maximum break down voltage.

5.7 Main switcher

Q1 is the main switcher for the system. It has a low R_{dson} to reduce the conduction loss. A drain-source capacitor C111 is added to the MOSFET to reduce the switching noise so as to get a better EMI performance.

5.8 Gate drive

The gate drive current is 0.17A push and 0.39A pull. The gate on signal has installed with a slope controlled rising edge feature which make the driving softly. If it needs to optimize the EMI performance, a turn off diode (D13) is added in parallel with the gate drive resistor (R16) so as to turn the device off faster than it is turned on.

5.9 Peak current control of primary current

The power MOSFET drain source current is sensed via external shunt resistors R14 and R15 which determine the tolerance of the current limit control. Since ICE3GS03LJG is a current mode controller, it would have a cycle-by-cycle primary current and feedback voltage control which can make sure the maximum power of the converter is controlled in every switching cycle. Besides, propagation delay compensation is implemented to ensure the maximum input current/power can be controlled in an even tighter manner. The demo board shows app. +/-4.81% (refer to Figure 12).

5.10 Output Stage

The power is coupled to the secondary side through schottky diode D21. The capacitor C22 provides energy buffering and the cascading LC filter L21 and C23 is used to reduce the output voltage ripple. The capacitor C22 is selected to have a low internal resistance (ESR) to minimize the output voltage ripple.

5.11 Feedback and regulation

The output voltage is controlled by a TL431 reference control IC (IC21). This device incorporates the voltage reference as well as the error amplifier. Compensation network C25, C26, R24, R25, R26, R27 and R28 constitutes the loop compensation circuit. This circuitry allows the feedback to be precisely matched to dynamically varying load conditions and provides stable control. The maximum current through the optocoupler diode and the voltage reference is set by using resistors R22 and R23. Optocoupler IC12 is used to transmit the control signal to the "Feedback" input of the ICE3GS03LJG device. The selected optocoupler should meet DIN VDE 884 requirements for a wider creepage distance.

5.12 Blanking Window for Load Jump

In case of Load Jumps the Controller provides a Blanking Window before activating the Over Load Protection and entering the Auto Restart Mode. There are 2 modes for the blanking time setting; basic mode and the extendable mode. If there is no capacitor added to the BL pin, it would fall into the basic mode; i.e. the blanking time is set at 20ms. If a longer blanking time is required, a capacitor, C19 can be added to BL pin to extend it. The extended time can be achieved by an internal 13uA constant current at BL pin to charge C19 ($C_{BK}=100nF$) from 0.9V to 4.0V. Thus the overall blanking time is the addition of 20ms and the extended time. During the operation the transferred power is limited to the maximum peak current defined by the value of the current sense resistor, R14 and R15.

$$T_{blanking} = Basic + Extended = 20ms + \frac{(4.0 - 0.9) * C_{BK}}{I_{BK}} = 20ms + 238461.5 * C_{BK} = 43.85ms$$

The blanking time to enter the Active Burst Mode is built-in at 20ms with no extension. If a low load condition is detected when V_{FB} is falling below 1.23V, the system will only enter Active Burst Mode after 20ms blanking time while V_{FB} is still below 1.23V.

Note: A filter capacitor (e.g. 100pF) may be needed to add to the BL pin if the noises cannot be avoided to enter that pin in the physical PCB layout. Otherwise, some protection features may be mis-triggered and the system may not be working properly.

5.13 Active Burst Mode

At light load condition, the SMPS enters into Active Burst Mode. At this stage, the controller is always active but the V_{CC} must be kept above the switch off threshold; i.e. $V_{CCoff} \geq 10.5V$. During active burst mode, the efficiency increases significantly and at the same time it supports low ripple on V_{OUT} and fast response on load jump. When the voltage level at FB falls below 1.23V, the internal blanking timer starts to count. When it reaches the built-in 20ms blanking time, it will enter Active Burst Mode. The Blanking Window is generated to avoid sudden entering of Burst Mode due to load jump.

During Active Burst Mode the current sense voltage limit is reduced from 1V to 0.25V so as to reduce the conduction losses and audible noise. All the internal circuits are switched off except the reference and bias voltages to reduce the total V_{CC} current consumption to below 0.45mA. At burst mode, the FB voltage is changing like a sawtooth between 3.0 and 3.5V. To leave Burst Mode, FB voltage must exceed 4.2V. It will

reset the Active Burst Mode and turn the SMPS into Normal Operating Mode. The maximum current; i.e. current sense voltage limit resume to 1V, can then be provided to stabilize V_{OUT} .

5.14 Jitter mode

The ICE3GS03LJG has frequency jittering feature to reduce the EMI noise. The jitter frequency is internally set at 130 kHz (± 5.2 kHz) and the jitter period is set at 4ms.

5.15 Protection modes

Protection is one of the major factors to determine whether the system is safe and robust. Therefore, sufficient protection is a must. ICE3GS03LJG provides all the necessary protections to ensure the system is operating safely. There are 2 kinds of protection mode; auto-restart and latch off mode. When there are serious faults such as V_{CC} over-voltage, over temperature and short winding, it enters the latch off mode. For those less severe faults such as over load, open loop, V_{CC} under-voltage and short optocoupler, it enters the auto-restart mode. In addition, there is an external latch enable feature which is suitable for those tailor-made protection features. A list of protections and the failure conditions are showed in the below table.

Protection function	Failure condition	Protection Mode
Vcc Over-voltage	$V_{CC} > 25.5V$	Latch off
Over-temperature (controller junction)	$T_J > 130^{\circ}C$	Latch off
Short winding / Short diode	$V_{CS} > 1.66V$	Latch off
External Latch off enable	$V_{BL} < 0.33V$	Latch off
Over-load / Open loop	$V_{FB} > 4.2V$ and $V_{BL} > 4.0V$ and after Blanking time	Auto Restart
Vcc Under-voltage / short Opto-coupler	$V_{CC} < 10.5V$	Auto Restart

6 Circuit Diagram

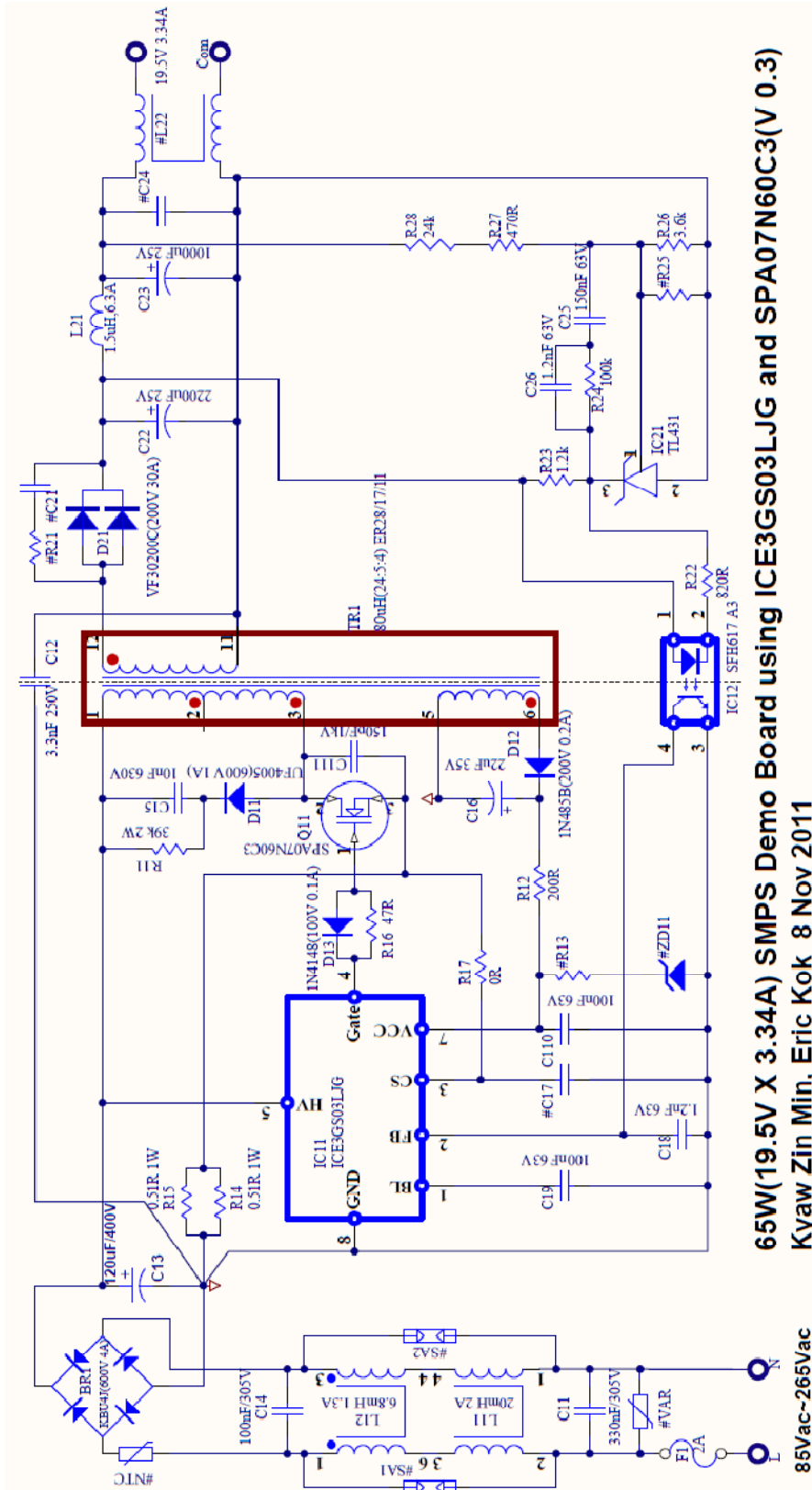

Figure 2 – 65W 19.5V ICE3GS03LJG power supply schematic

N.B.: In order to get the optimized performance of the PWM controller, the grounding of the PCB layout must be taken very carefully. From the circuit diagram above, it shows that the grounding for the PWM controller can be split into several groups; signal ground, Vcc ground, Current sense resistor ground and EMI return ground. All the split ground should be connected to the bulk capacitor ground separately.

- Signal ground includes all small signal grounds connecting to the PWM controller GND pin such as filter capacitor ground of C17, C18, C19, C110 and opto-coupler (IC12) ground.
- Vcc ground includes the Vcc capacitor ground, C16 and the auxiliary winding ground; pin 5 of the power transformer.
- Current Sense resistor ground includes current sense resistor R14 and R15.

7 PCB Layout

7.1 Top side

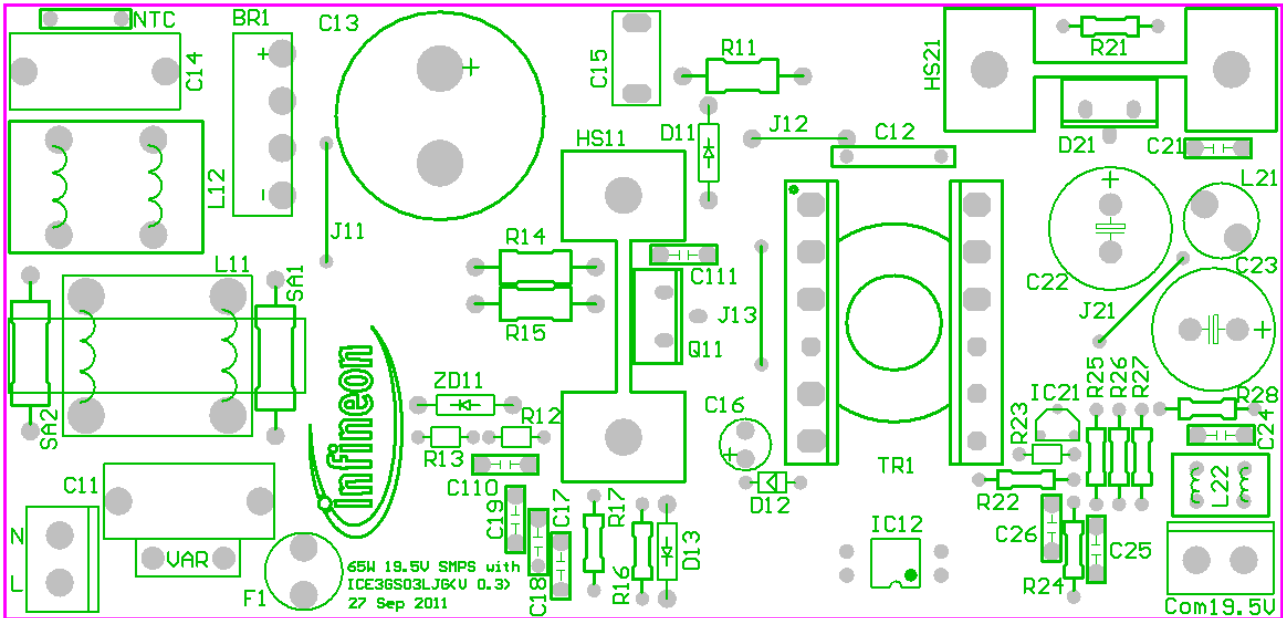

Figure 3 – Top side component legend

7.2 Bottom side

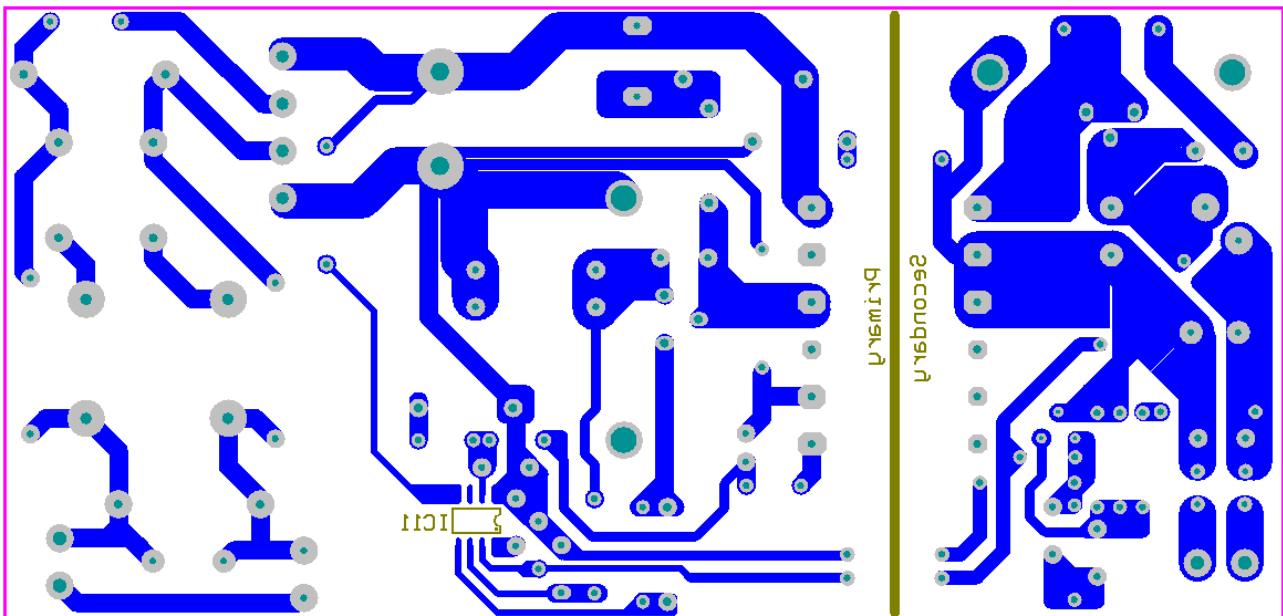

Figure 4 – Bottom side copper & component legend

8 Component List

No.	Designator	Component description	Part No.	Manufacturer
1	BR1	KBU4J(600V 4A)	KBU4J-E4/51	VISHAY
2	C11	330nF/305V	B32922C3334M+***	EPCOS
3	C12	3.3nF/250V	DE1E3KX332MA4BL01	MURATA
4	C13	120uF/400V	B43504A9127M00*	EPCOS
5	C14	100nF/305V	B32922A2104+***	EPCOS
6	C15	10nF/ 630V		
7	C16	22uF/35V		
8	C18, C26	1.2nF/63V		
9	C22	2200uF/25V		
10	C23	1000uF/25V		
11	C25	150nF/ 63V		
12	C19,C110	100nF/ 63V		
13	C111	150pF/1kV	DESD33A151KA2B	MURATA
14	D11	UF4005(600V, 1A)	UF4005	VISHAY
15	D12	1N485B(200V, 0.2A)		
16	D13	1N4148		
17	D21	VF30200C(200V, 30A)	VF30200C-E3/4W	VISHAY
18	F1	2A/250V		
19	HS11, HS21	Heat Sink		
20	IC11	ICE3GS03LJG	ICE3GS03LJG	INFINEON
21	IC12	SFH617 A3		
22	IC21	TL431		
23	J11,J12,J13,J21,NTC,L22,R17	Jumper		
24	L N, +19.5V Com	Connector		
25	L11	20mH 2A	B82734R2202B030	EPCOS
26	L12	6.8mH 1.3A	B82731T2132A020	EPCOS
27	L21	1.5uH,6.3A		
28	Q11	650V(0.6Ω, 7.3A)	SPA07N60C3	INFINEON
29	R11	39k/2W		
30	R12	200R		
31	R14, R15	0.51R(1W, 1%)		
32	R16	47R		
33	R22	820R		
34	R23	1.2k		
35	R24	100k		
36	R26	3.6k/1%		
37	R27	470R/1%		
38	R28	24k/1%		
39	TR1	80μH(24:5:4)ER28/17/11	B66433G0000X172	EPCOS

9 Transformer Construction

Core and material: ER28/17/11 (N72)

Bobbin: BEER28L-1110CPFR (Vertical type)

Primary Inductance, $L_p = 80\mu\text{H}$ ($\pm 5\%$), measured between pin 1 and pin 3 (Gapped to Inductance)

Transformer structure:

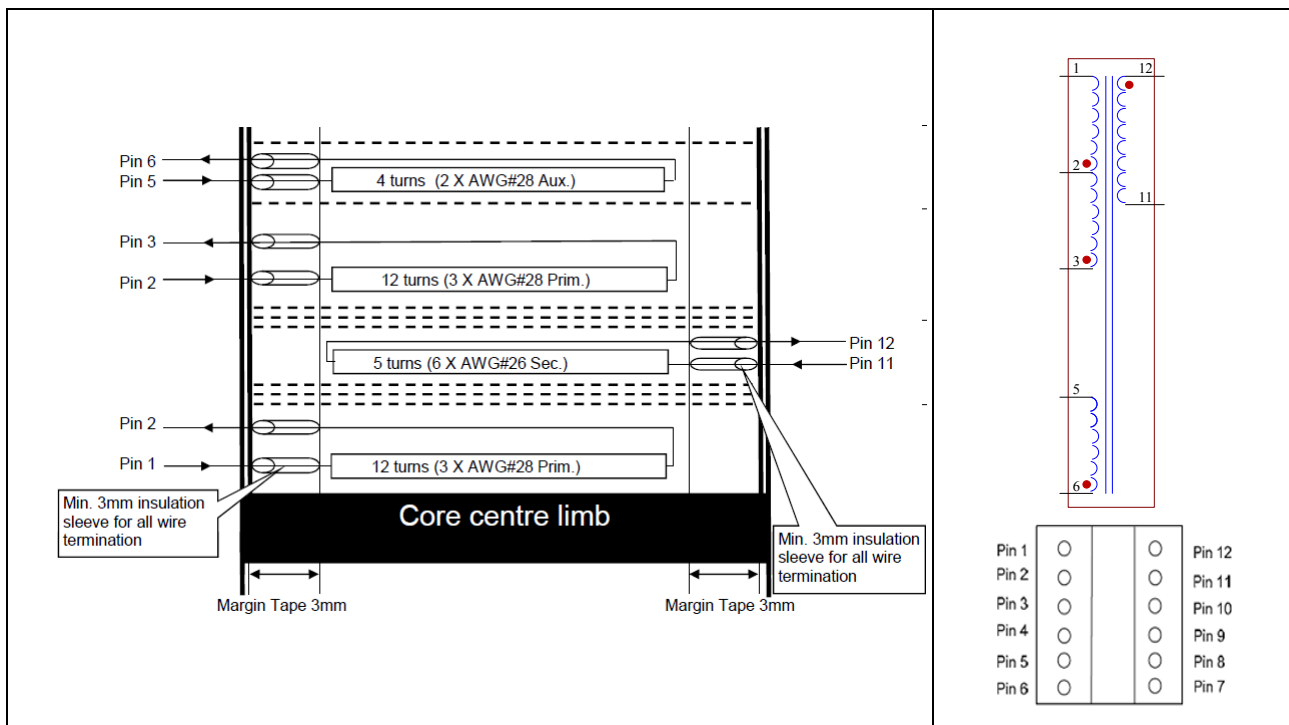

Figure 5 – Transformer structure and top view of transformer complete

Wire size requirement:

Start	Stop	No. of turns	Wire size	Layer
1	2	12	3XAWG#28	$1/2$ Primary
11	12	5	6XAWG#26	Secondary
2	3	12	3XAWG#28	$1/2$ Primary
5	6	4	2XAWG#28	Aux.

10 Test results

10.1 Efficiency

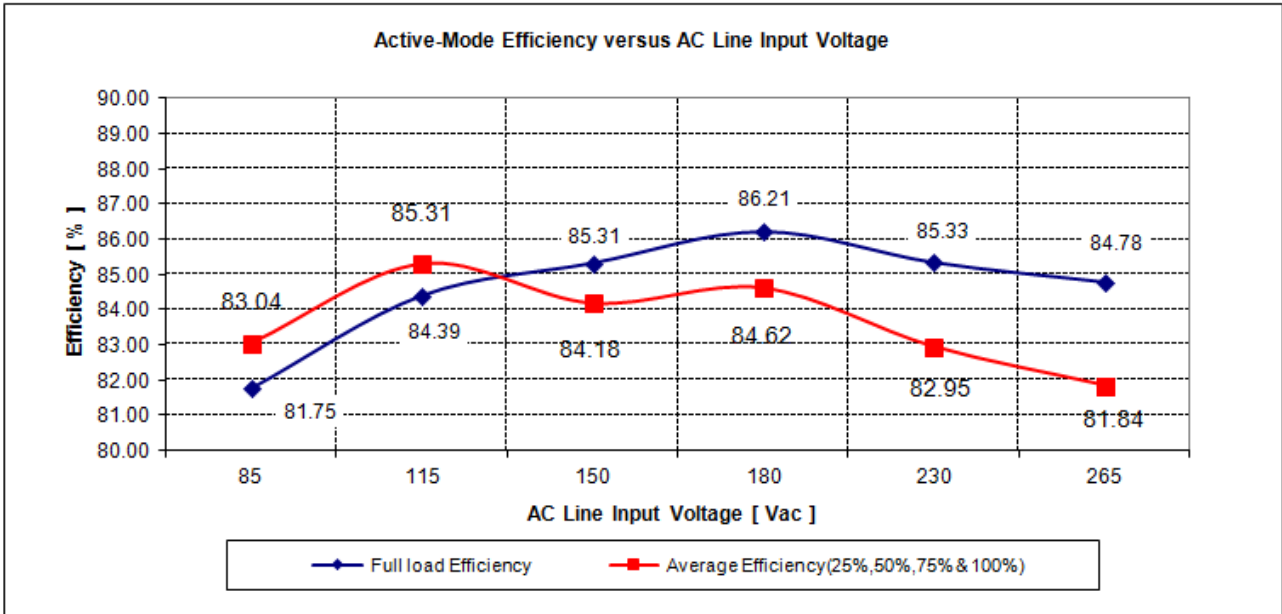

Figure 6 – Efficiency Vs. AC line input voltage

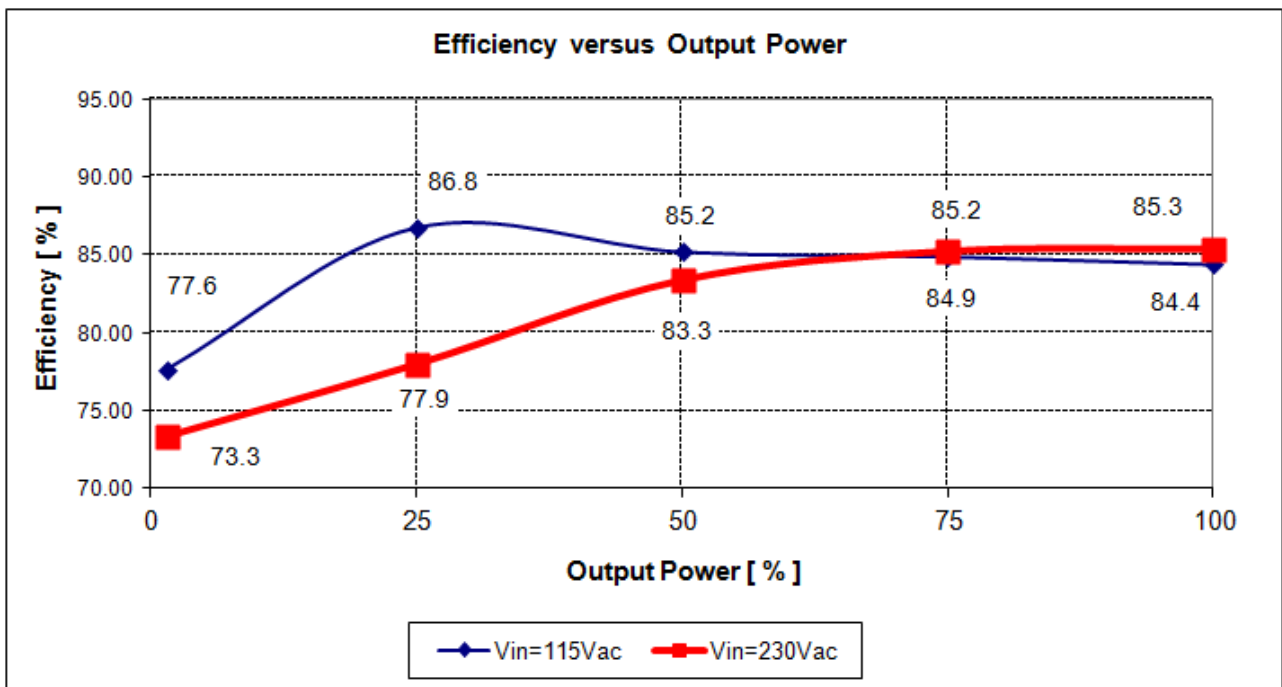

Figure 7 – Efficiency Vs. output power @ low and high Line

10.2 Input standby power

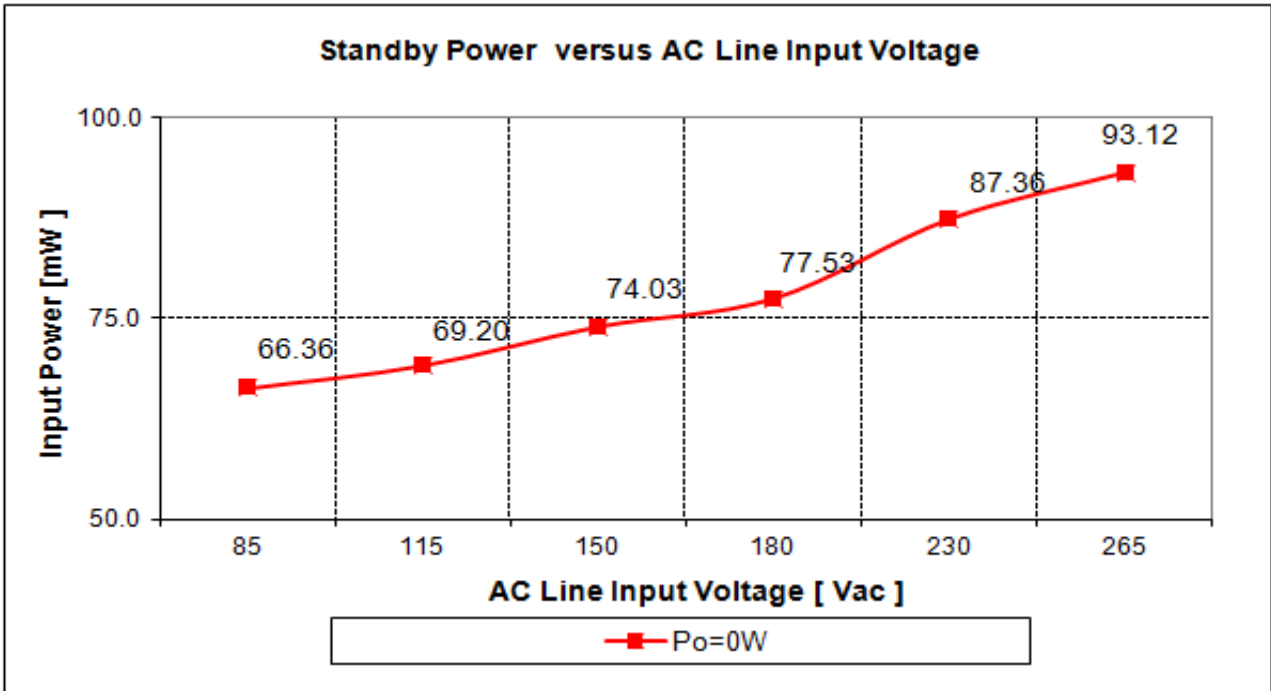

Figure 8 – Input standby power @ no load Vs. AC line input voltage (measured by Yokogawa WT210 power meter - integration mode)

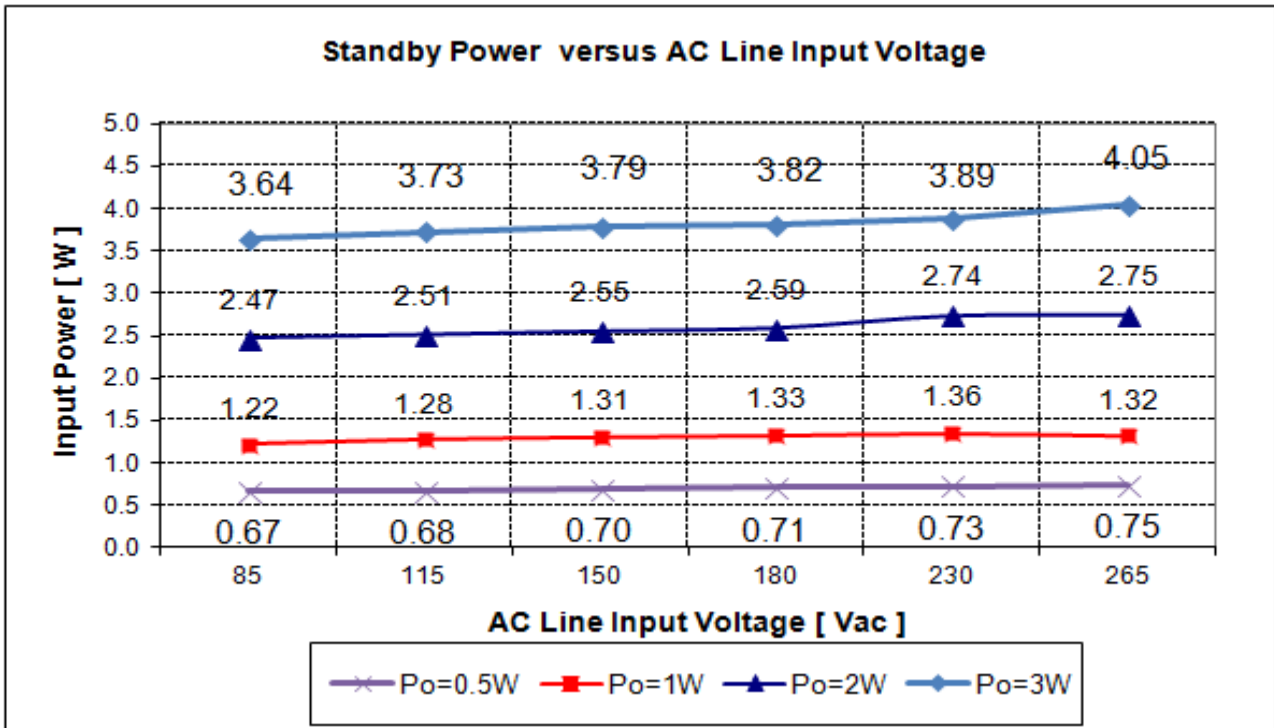

Figure 9 – Input standby power @ 0.5W, 1W, 2W & 3W Vs. AC line input voltage (measured by Yokogawa WT210 power meter - integration mode)

10.3 Line regulation

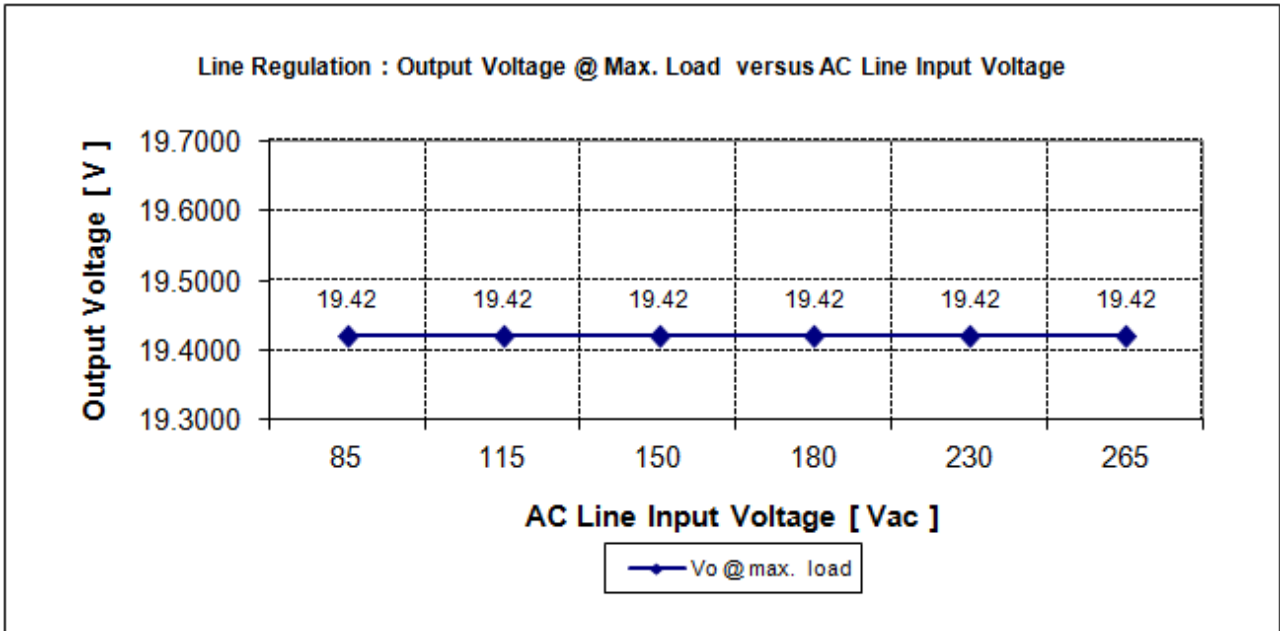

Figure 10 – Line regulation Vout @ full load vs. AC line input voltage

10.4 Load regulation

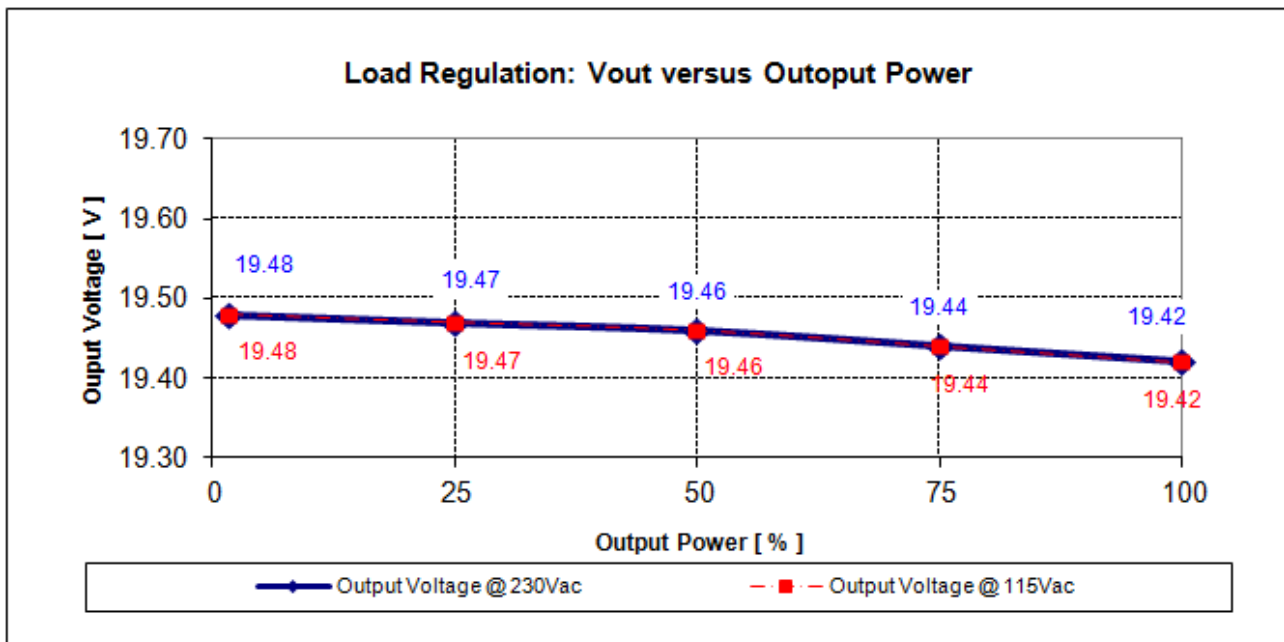

Figure 11 – Load regulation Vout vs. output power

10.5 Maximum input power

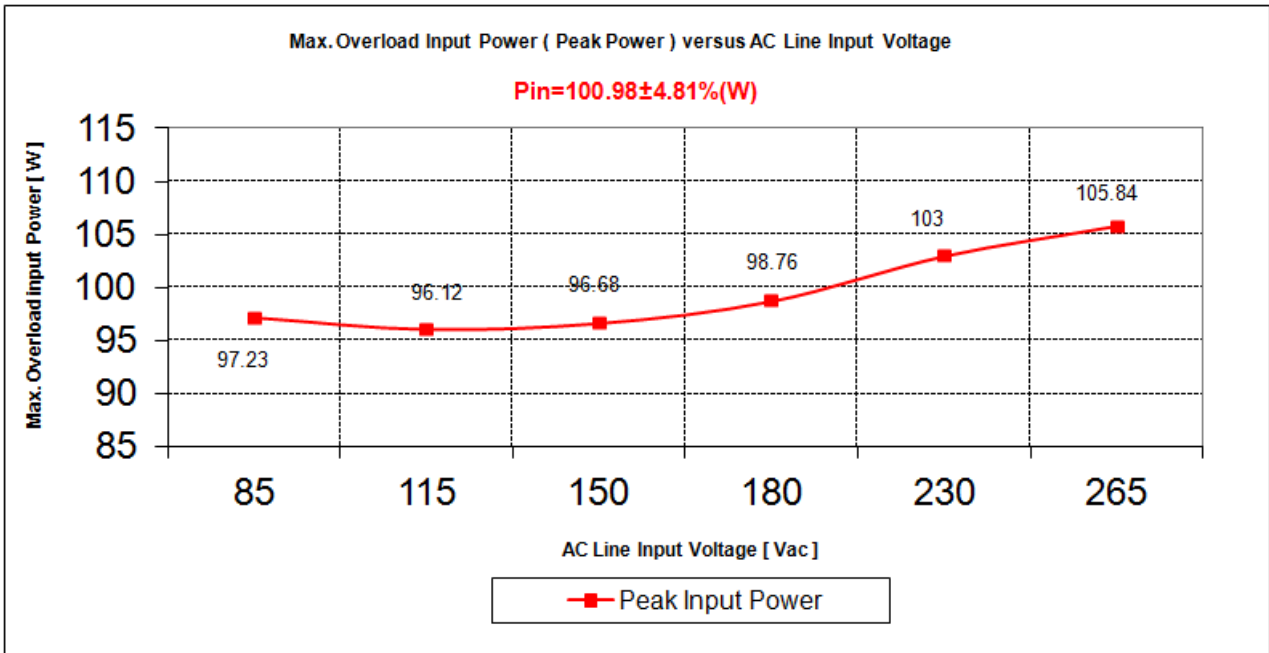

Figure 12 – Maximum input power (before overload protection) vs. AC line input voltage

10.6 ESD test

Pass (EN61000-4-2): 20kV for contact discharge (without surge absorber device)

10.7 Lightning surge test

Pass (EN61000-4-5): 4kV for line to earth (without surge absorber device)

Pass (EN61000-4-5): 6kV for line to earth (with surge absorber device; SA1 & SA2 (DA38-102MB))

10.8 Conducted EMI

The conducted EMI was measured by Schaffner (SMR4503) and followed the test standard of EN55022 (CISPR 22) class B. The demo board was set up at maximum load (65W) with input voltage of 115Vac and 230Vac.

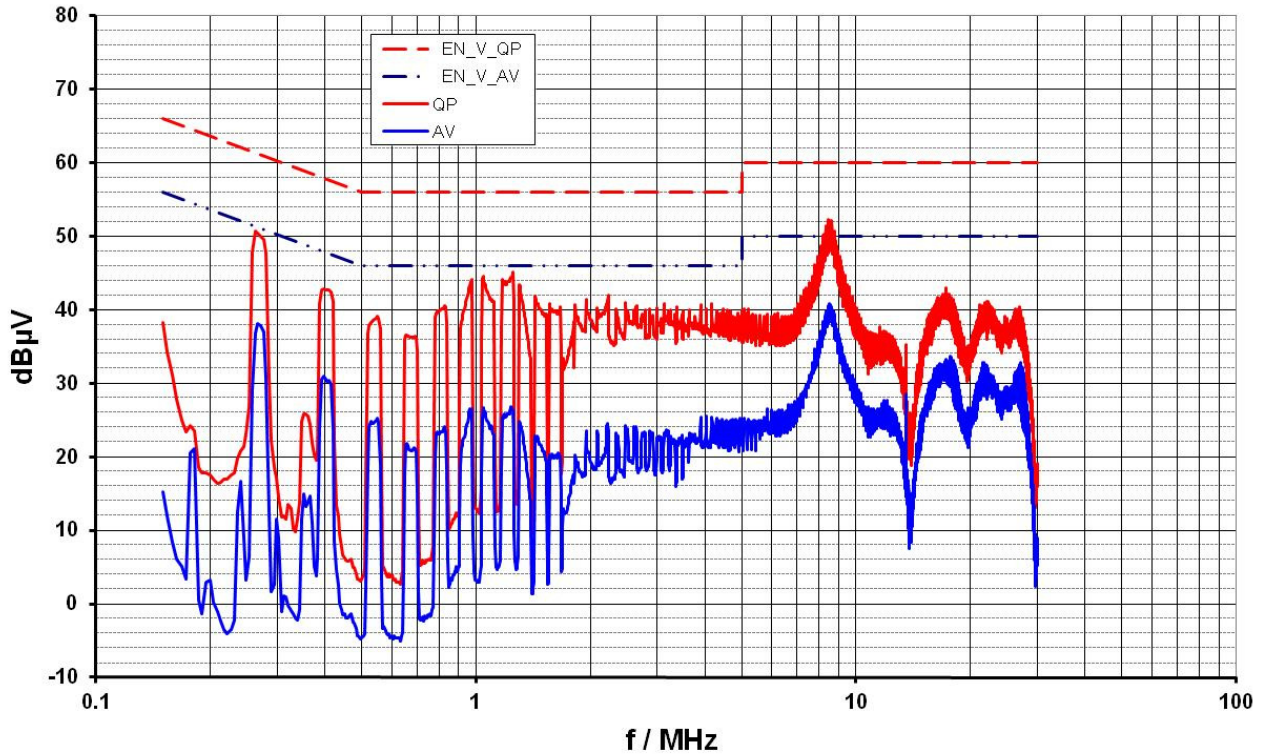

Figure 13 – Maximum load (65W) with 115 Vac (Line)

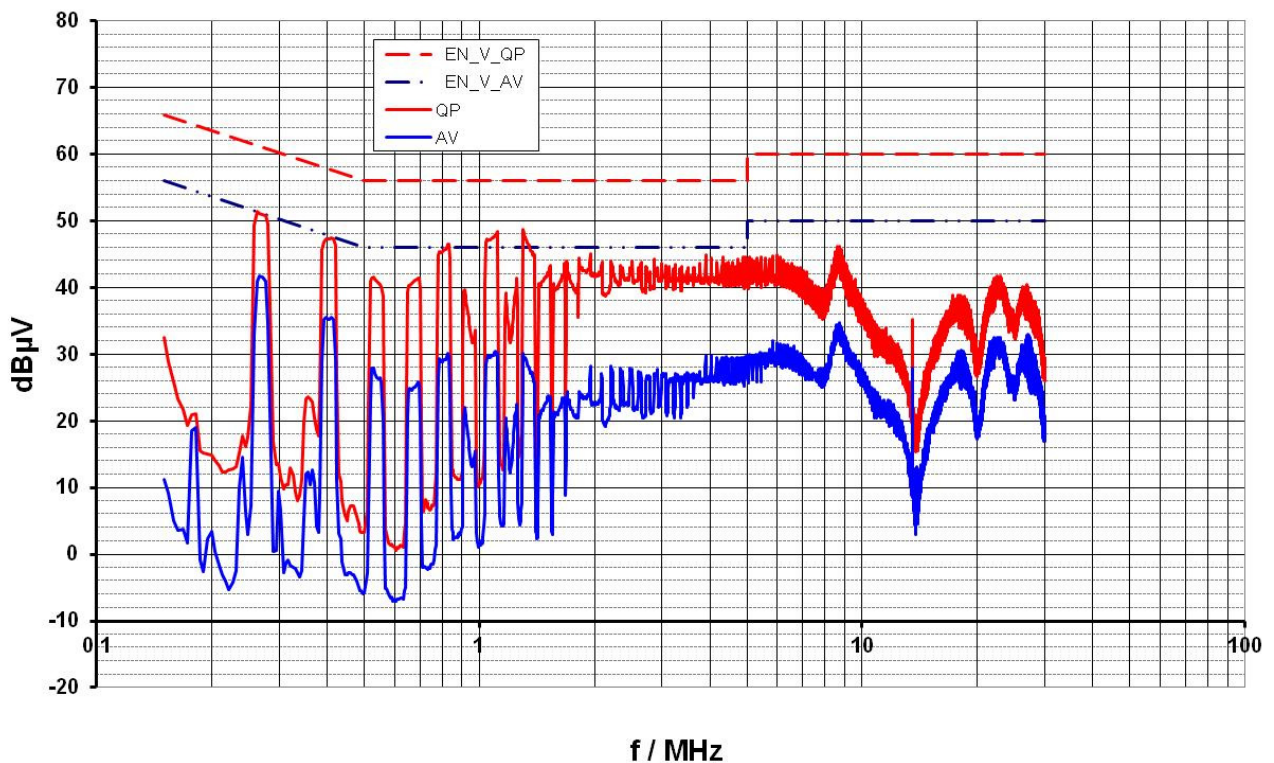

Figure 14 – Maximum load (65W) with 115 Vac (Neutral)

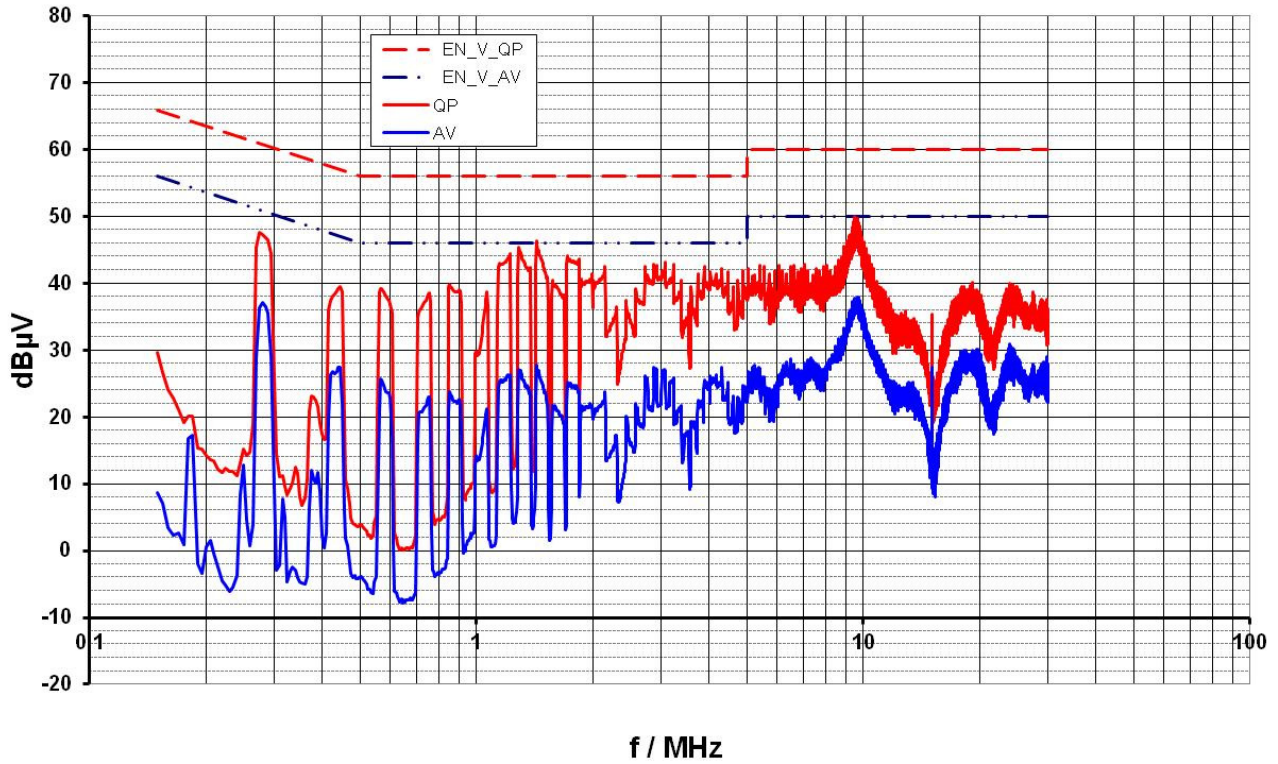

Figure 15 – Maximum load (65W) with 230 Vac (Line)

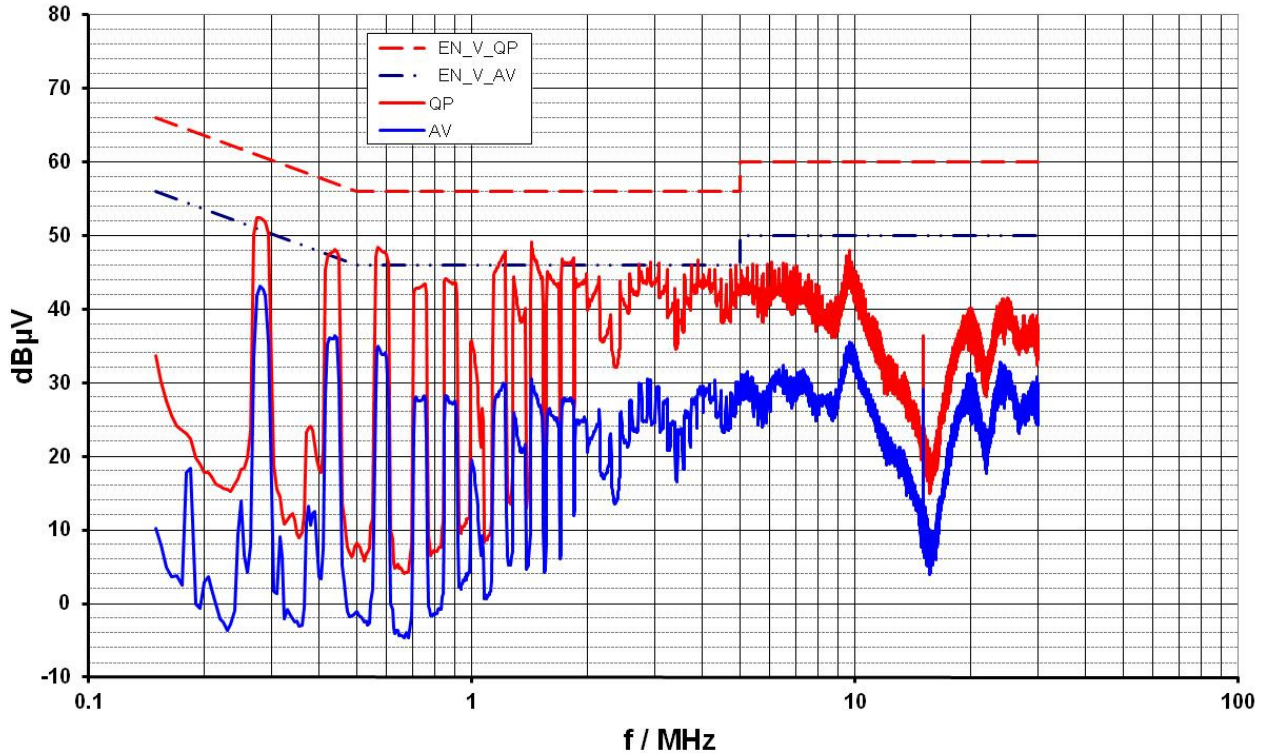

Figure 16 – Maximum load (65W) with 230 Vac (Neutral)

Pass conducted EMI EN55022 (CISPR 22) class B with > 6dB margin.

11 Waveforms and scope plots

All waveforms and scope plots were recorded with a LeCroy 6050 oscilloscope

11.1 Start up at low and high AC line input voltage and maximum load

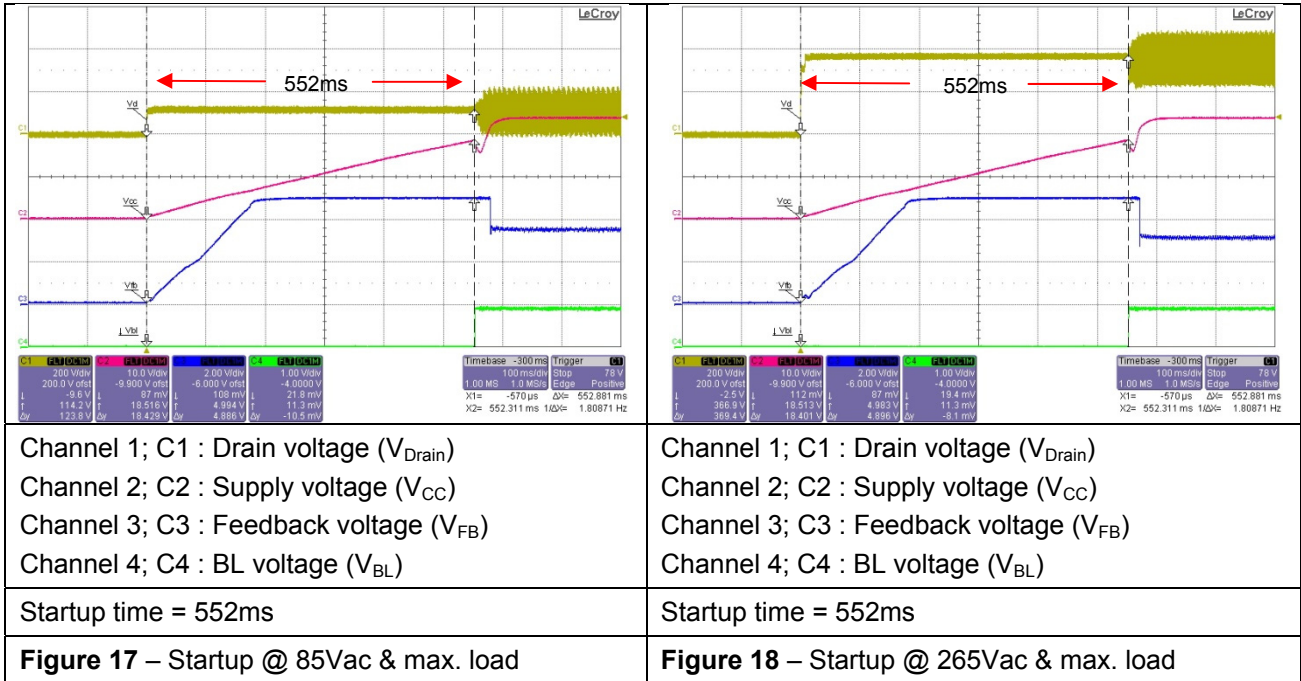

11.2 Soft start at low and high AC line input voltage and maximum load

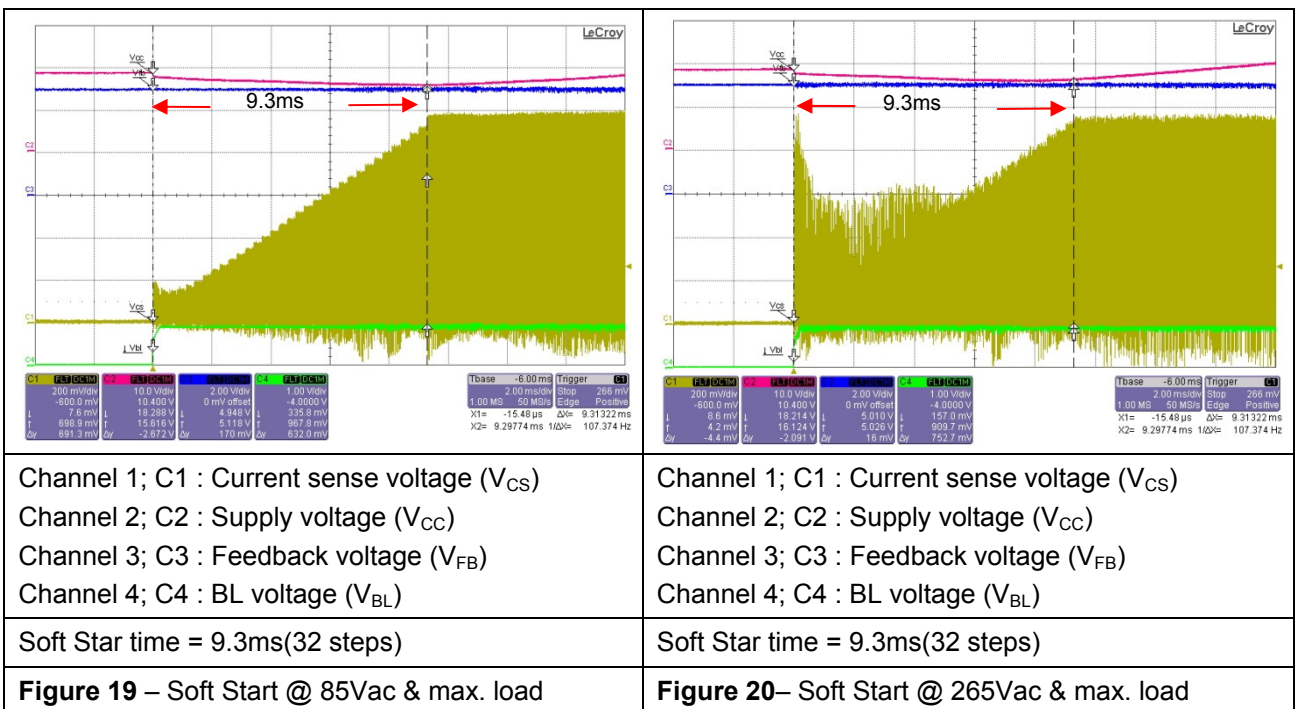

11.3 Frequency jittering

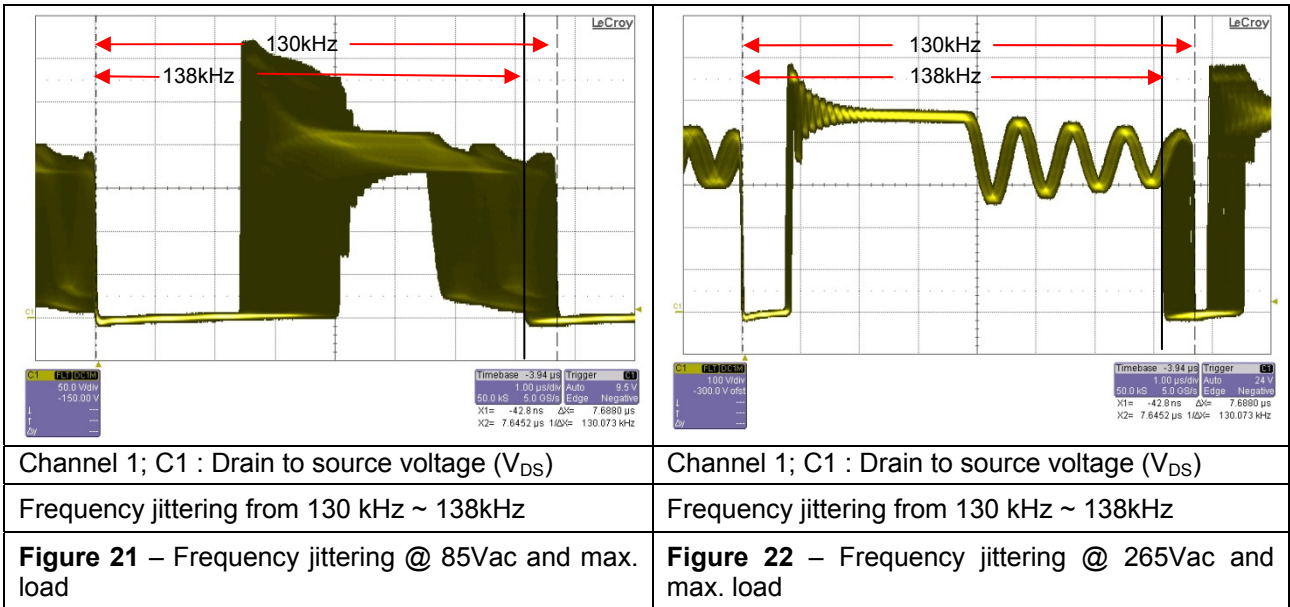

11.4 Drain to source voltage and current @ maximum load

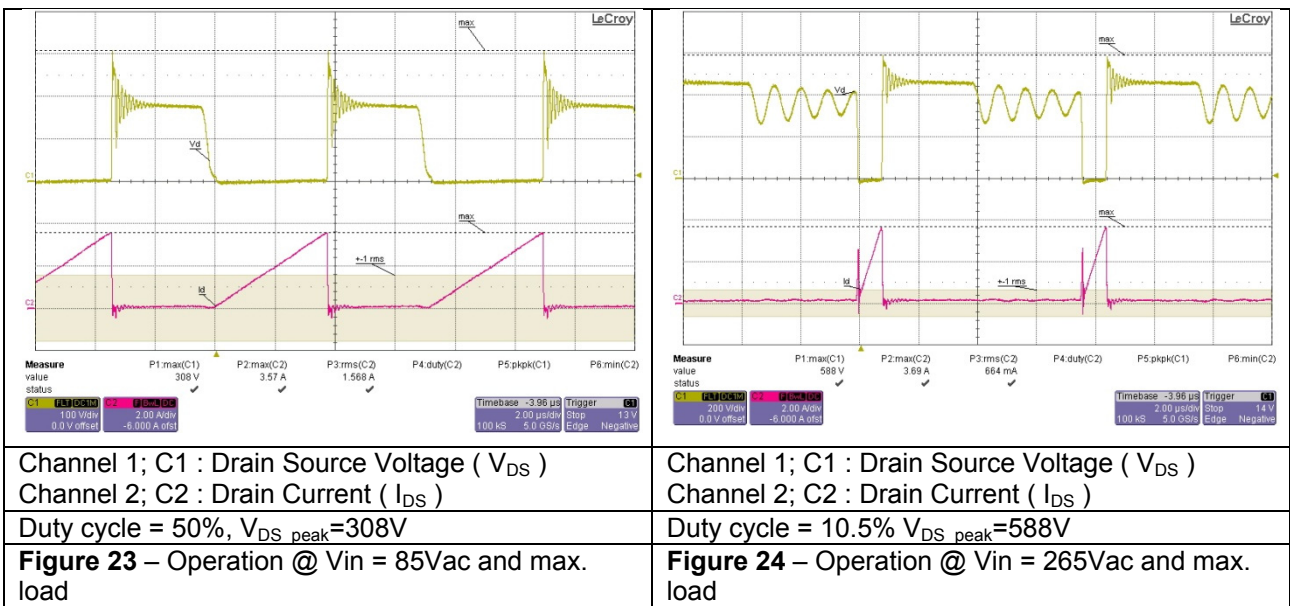

11.5 Load transient response (Dynamic load from 10% to 100%)

<p>Channel 2; C2 : Output Ripple Voltage (V_{o_ripple})</p>	<p>Channel 2; C2 : Output Ripple Voltage (V_{o_ripple})</p>
<p>$V_{ripple_pk_pk}=227.4\text{mV}$ (Load change from 10% to 100%, 100Hz, 0.4A/μS slew rate) Probe terminal end with decoupling capacitor of 0.1μF(ceramic) & 1μF(Electrolytic), 20MHz filter</p>	<p>$V_{ripple_pk_pk}=225.9\text{mV}$ (Load change from 10% to 100%, 100Hz, 0.4A/μS slew rate) Probe terminal end with decoupling capacitor of 0.1μF(ceramic) & 1μF(Electrolytic), 20MHz filter</p>
<p>Figure 25 – Load transient response @ 85Vac</p>	<p>Figure 26 – Load transient response @ 265Vac</p>

11.6 Output ripple voltage at maximum load

<p>Channel 2; C2 : Output Ripple Voltage (V_{o_ripple})</p>	<p>Channel 2; C2 : Output Ripple Voltage (V_{o_ripple})</p>
<p>$V_{ripple_pk_pk}=41.8\text{mV}$ Probe terminal end with decoupling capacitor of 0.1μF(ceramic) & 1μF(Electrolytic), 20MHz filter</p>	<p>$V_{ripple_pk_pk}=43.3\text{mV}$ Probe terminal end with decoupling capacitor of 0.1μF(ceramic) & 1μF(Electrolytic), 20MHz filter</p>
<p>Figure 27 – AC output ripple @ $V_{in}=85\text{Vac}$ and max. load</p>	<p>Figure 28 – AC output ripple @ $V_{in}=265\text{Vac}$ and max. load</p>

11.7 Output ripple voltage during burst mode at 1 W load

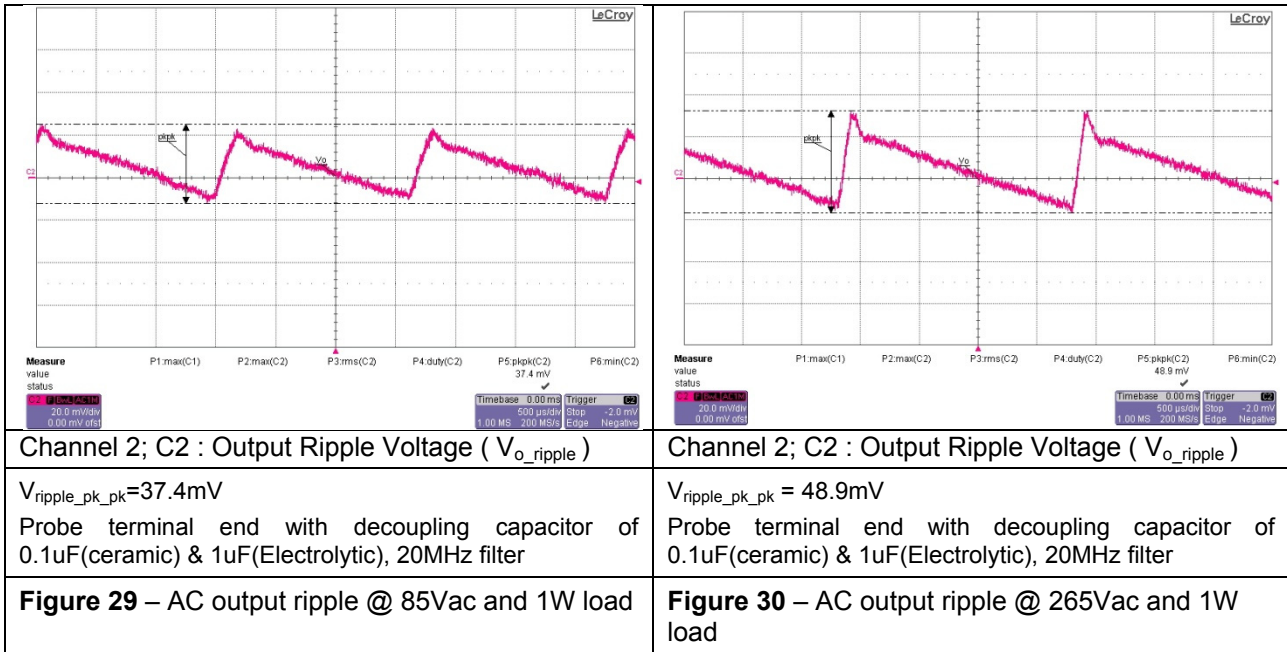

11.8 Entering active burst mode

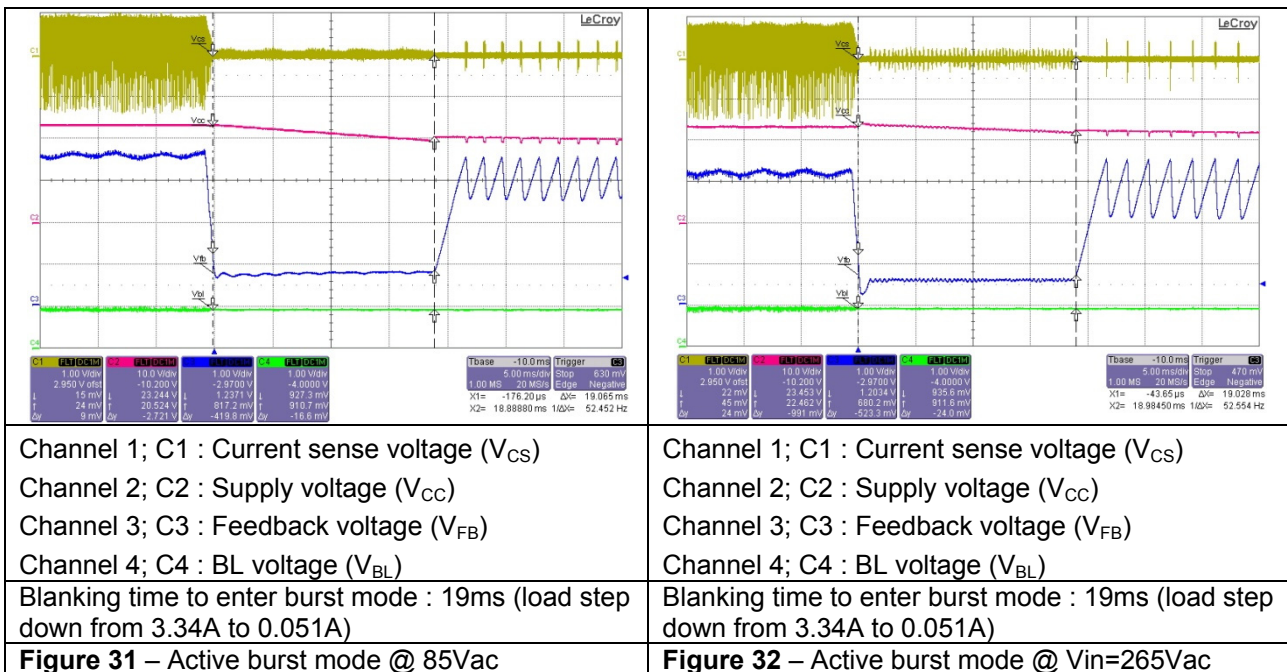

11.9 Vcc overvoltage protection (Latch off)

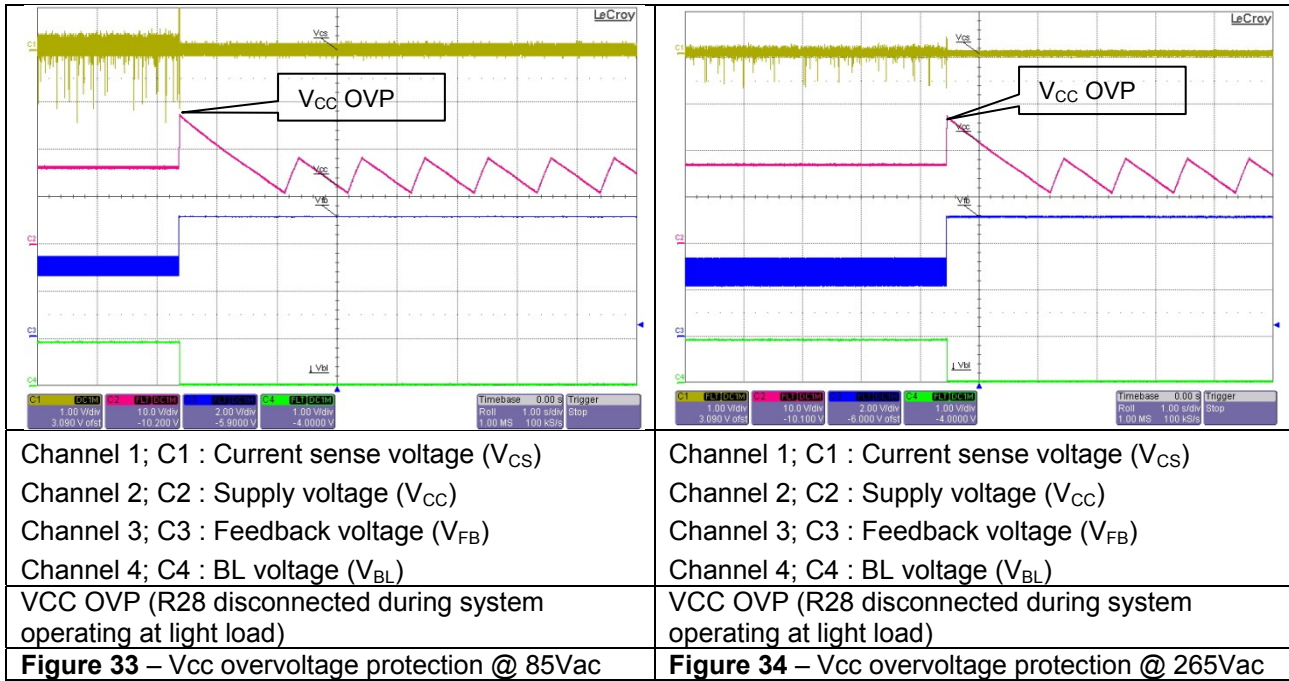

11.10 External protection enable (Latch off)

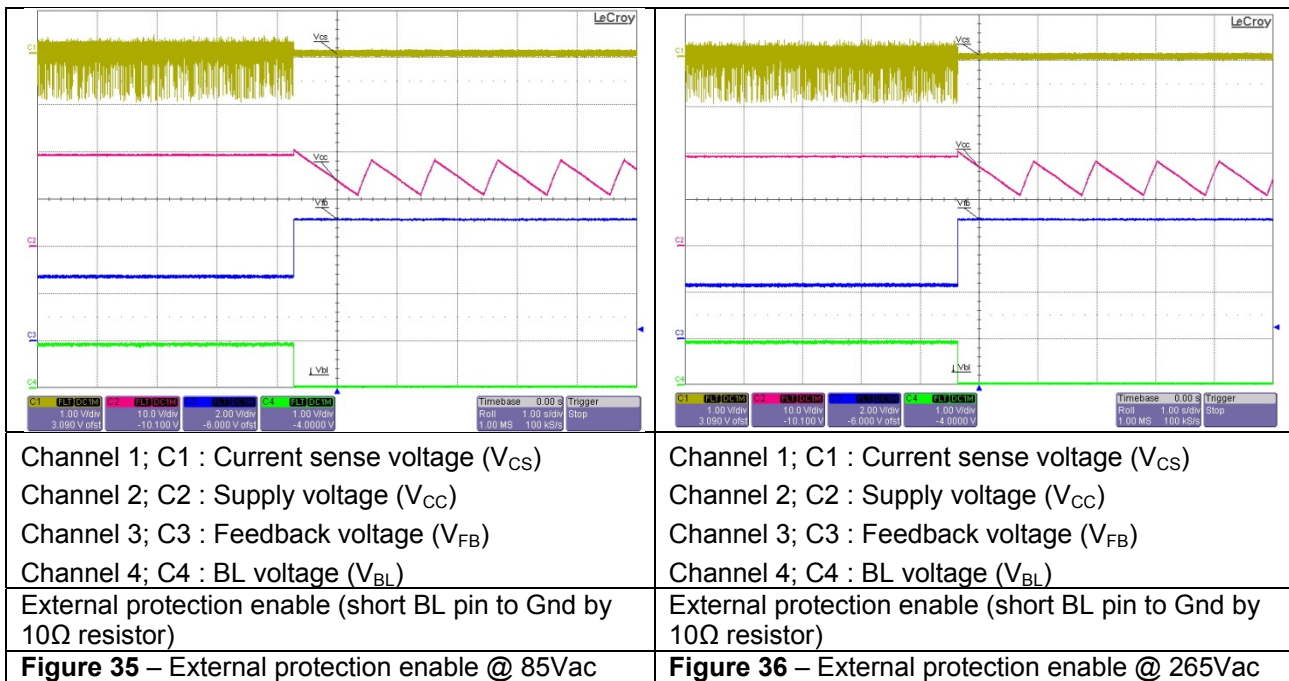

11.11 Over load protection (built-in + extended blanking time) (Auto restart)

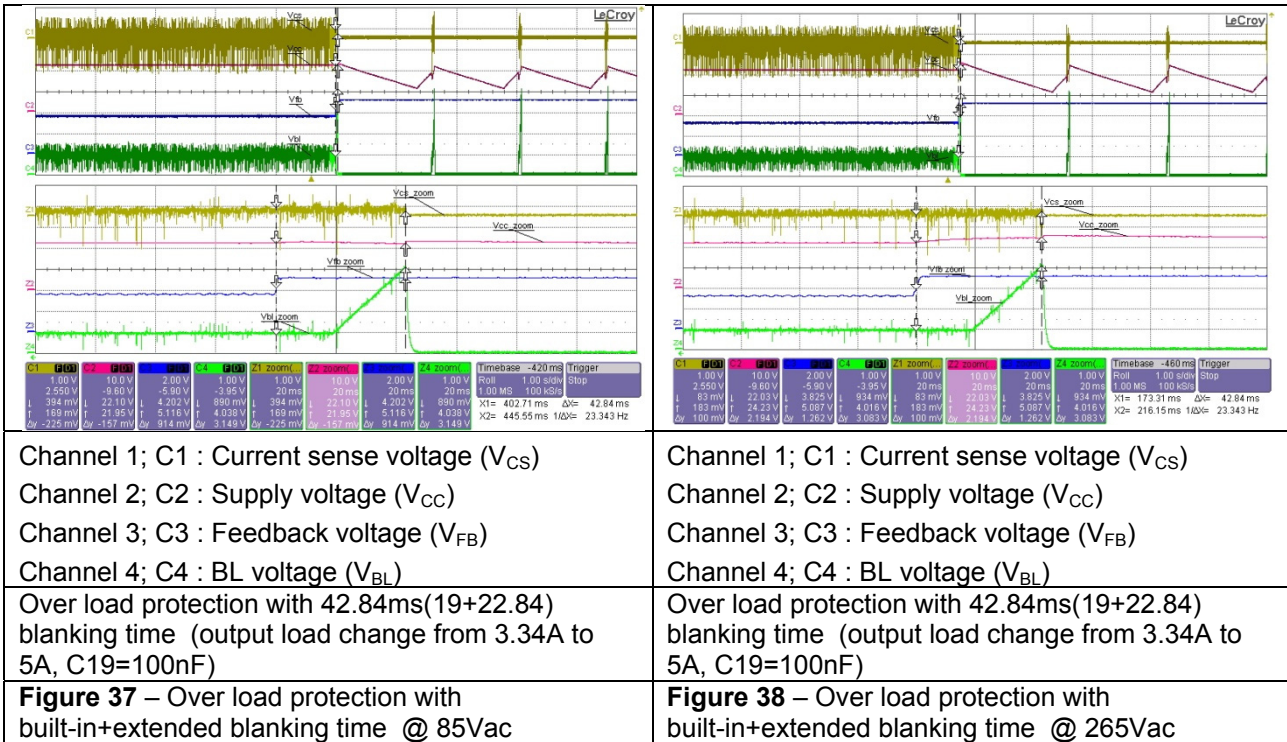

11.12 Open loop protection (Auto restart)

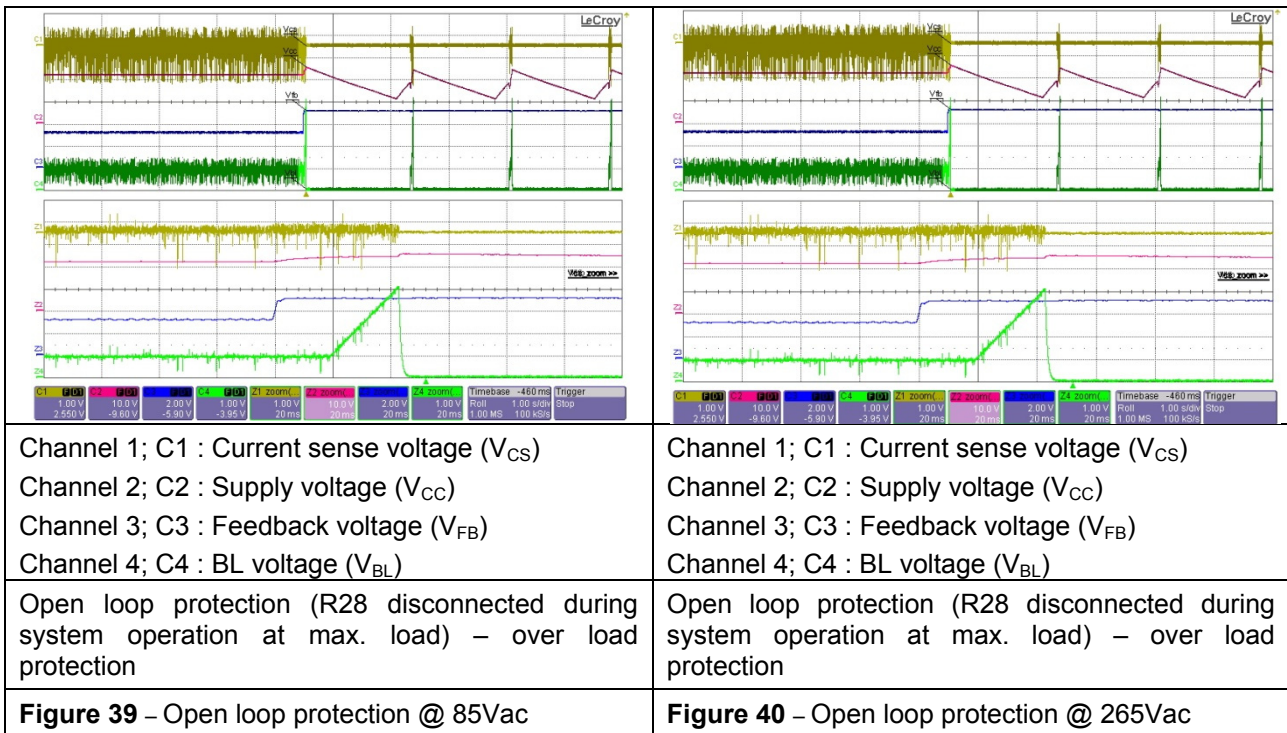

11.13 V_{CC} under voltage/Short optocoupler protection (Auto restart)

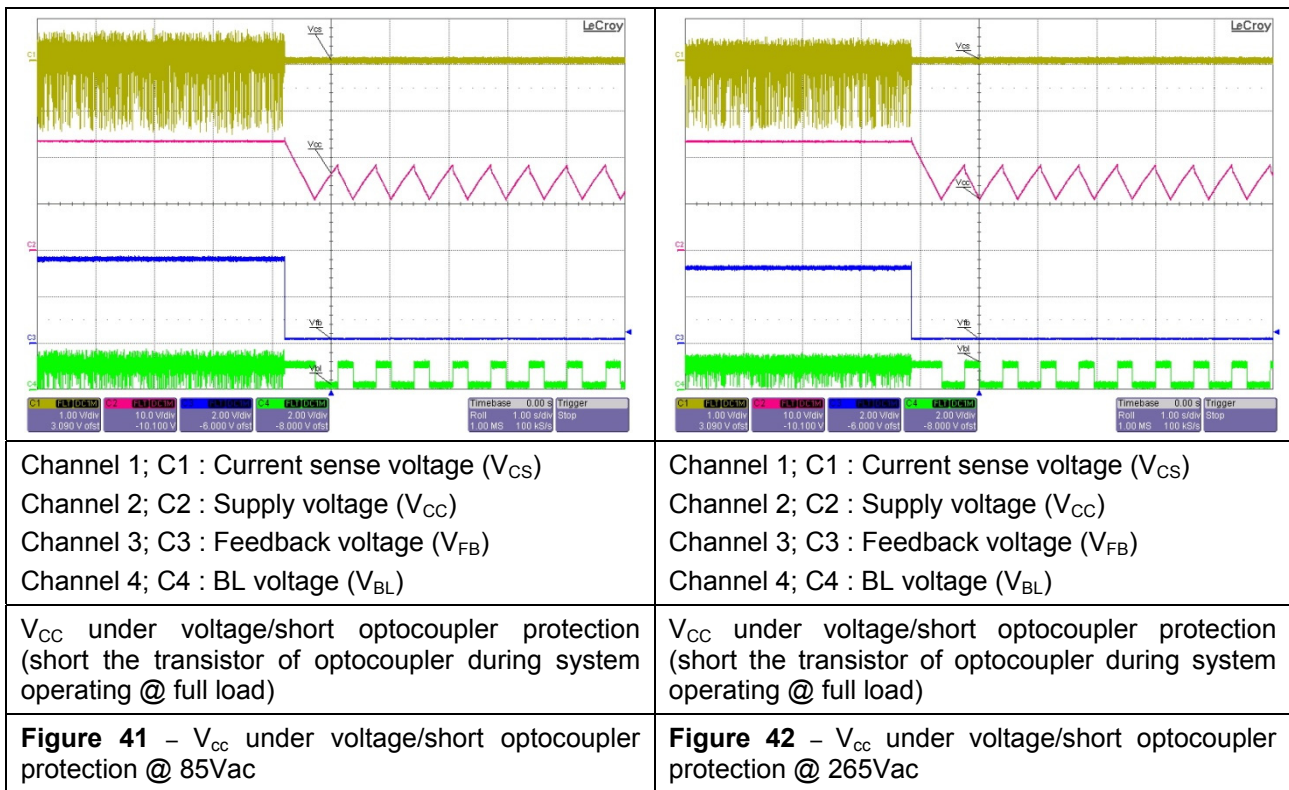

12 References

- [1] Infineon Technologies, Datasheet “F3 PWM controller ICE3GS03LJG Off-Line SMPS Current Mode Controller with Integrated 500V Startup Cell (Latched and Frequency Jitter Mode)”
- [2] Infineon Technologies, Application Note “AN-SMPS-ICE2xXXX-1 CoolSET™ ICE2xXXX for OFF-Line Switch Mode Power Supply (SMPS)”
- [3] Infineon Technologies, Application Note “ICE3XS03LJG F3 Fixed Frequency PWM Controller (Latch & Jitter version) Design Guide”



Стандарт Электрон Связь

Мы молодая и активно развивающаяся компания в области поставок электронных компонентов. Мы поставляем электронные компоненты отечественного и импортного производства напрямую от производителей и с крупнейших складов мира.

Благодаря сотрудничеству с мировыми поставщиками мы осуществляем комплексные и плановые поставки широчайшего спектра электронных компонентов.

Собственная эффективная логистика и склад в обеспечивает надежную поставку продукции в точно указанные сроки по всей России.

Мы осуществляем техническую поддержку нашим клиентам и предпродажную проверку качества продукции. На все поставляемые продукты мы предоставляем гарантию .

Осуществляем поставки продукции под контролем ВП МО РФ на предприятия военно-промышленного комплекса России , а также работаем в рамках 275 ФЗ с открытием отдельных счетов в уполномоченном банке. Система менеджмента качества компании соответствует требованиям ГОСТ ISO 9001.

Минимальные сроки поставки, гибкие цены, неограниченный ассортимент и индивидуальный подход к клиентам являются основой для выстраивания долгосрочного и эффективного сотрудничества с предприятиями радиоэлектронной промышленности, предприятиями ВПК и научно-исследовательскими институтами России.

С нами вы становитесь еще успешнее!

Наши контакты:

Телефон: +7 812 627 14 35

Электронная почта: sales@st-electron.ru

Адрес: 198099, Санкт-Петербург,
Промышленная ул, дом № 19, литера Н,
помещение 100-Н Офис 331