

HCPL-3150 (Single Channel), HCPL-315J (Dual Channel)

0.5 Amp Output Current IGBT Gate Drive Optocoupler

Overview

The Broadcom[®] HCPL-315X consists of an LED optically coupled to an integrated circuit with a power output stage. This optocoupler is ideally suited for driving power IGBTs and MOSFETs used in motor control inverter applications. The high operating voltage range of the output stage provides the drive voltages required by gate-controlled devices. The voltage and current supplied by this optocoupler makes it ideally suited for directly driving IGBTs with ratings up to 1200V/50A. For IGBTs with higher ratings, the HCPL-3150/315J can be used to drive a discrete power stage which drives the IGBT gate.

Applications

- Isolated IGBT/MOSFET gate drive
- AC and brushless DC motor drives
- Industrial inverters
- Switch mode power supplies (SMPSs)
- Uninterruptable power supplies (UPSs)

Features

- 0.6A maximum peak output current
- 0.5A minimum peak output current
- 15-kV/ μ s minimum Common Mode Rejection (CMR) at $V_{CM} = 1500V$
- 1.0V maximum low level output voltage (V_{OL}) eliminates need for negative gate drive
- $I_{CC} = 5$ mA maximum supply current
- Under voltage lock-out protection (UVLO) with hysteresis
- Wide operating V_{CC} range: 15V to 30V
- 0.5- μ s maximum propagation delay
- ± 0.35 - μ s maximum delay between devices/channels
- Industrial temperature range: $-40^{\circ}C$ to $100^{\circ}C$
- HCPL-315J: channel one to channel two output isolation = 1500 Vrms/1 min.
- Safety and regulatory approval:
 - UL recognized (UL1577),
3750 Vrms/1 min. (HCPL-3150)
5000 Vrms/1 min. (HCPL-315J)
 - IEC/EN/DIN EN 60747-5-5 approved
 $V_{IORM} = 630 V_{peak}$ (HCPL-3150 option 060 only)
 $V_{IORM} = 1414 V_{peak}$ (HCPL-315J) CSA certified

CAUTION! It is advised that normal static precautions be taken in handling and assembly of this component to prevent damage and/or degradation that may be induced by ESD. The components featured in this data sheet are not to be used in military or aerospace applications or environments.

Functional Diagram

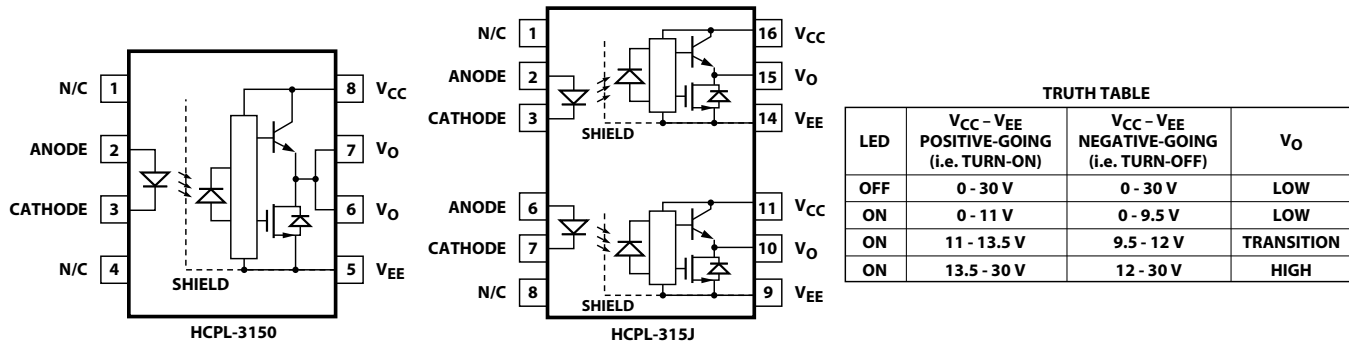

NOTE: A 0.1- μ F bypass capacitor must be connected between the V_{CC} and V_{EE} pins for each channel.

Selection Guide: Inverter Gate Drive Optoisolators

| Package Type | 8-Pin DIP (300 mil) | | | | Widebody (400 mil) | Small Outline SO-16 | | |
|--------------------------------------|---|-----------|--------------------------------------|----------------|--------------------------------------|--------------------------------------|-----------|----------------|
| Part Number | HCPL-3150 | HCPL-3120 | HCPL-J312 | HCPL-J314 | HCNW-3120 | HCPL-315J | HCPL-316J | HCPL-314J |
| Number of Channels | 1 | 1 | 1 | 1 | 1 | 2 | 1 | 2 |
| IEC/EN/DIN EN 60747-5-5 Approvals | V_{IORM} 630 V _{peak} Option 060 | | V_{IORM} 1230 V _{peak} | | V_{IORM} 1414 V _{peak} | V_{IORM} 1414 V _{peak} | | |
| UL Approval | 5000 Vrms/1 min. | | 5000 Vrms/1min. | | 5000 Vrms/ 1 min. | 5000 Vrms/1 min. | | |
| Output Peak Current | 0.5A | 2A | 2A | 0.4A | 2A | 0.5A | 2A | 0.4A |
| CMR (Minimum) | 15 kV/ μ s | | | 10 kV/ μ s | 15 kV/ μ s | | | 10 kV/ μ s |
| UVLO | Yes | | | No | Yes | | | No |
| Fault Status | No | | | | | Yes | | No |

Ordering Information

HCPL-3150 is UL Recognized with 3750 Vrms for 1 minute per UL1577. HCPL-315J is UL Recognized with 5000 Vrms for 1 minute per UL1577.

| Part Number | Option | | Package | Surface Mount | Gull Wing | Tape & Reel | IEC/EN/DIN EN 60747-5-5 | Quantity |
|-------------|----------------|--------------------|---------------|---------------|-----------|-------------|-------------------------|---------------|
| | RoHS Compliant | Non RoHS Compliant | | | | | | |
| HCPL-3150 | -000E | No option | 300 mil DIP-8 | | | | | 50 per tube |
| | -300E | #300 | | X | X | | | 50 per tube |
| | -500E | #500 | | X | X | X | | 1000 per reel |
| | -060E | #060 | | | | | X | 50 per tube |
| | -360E | #360 | | X | X | | X | 50 per tube |
| | -560E | #560 | | X | X | X | X | 1000 per reel |
| | -560ME | No option | | X | X | X | X | 1000 per reel |
| HCPL-315J | -000E | No option | SO-16 | X | | | X | 45 per tube |
| | -500E | #500 | | X | | X | X | 850 per reel |

To order, choose a part number from the part number column and combine with the desired option from the option column to form an order entry.

Example 1:

HCPL-3150-560E to order product of 300 mil DIP Gull Wing Surface Mount package in Tape and Reel packaging with IEC/EN/DIN EN 60747-5-5 Safety Approval in RoHS compliant.

Example 2:

HCPL-3150 to order product of 300 mil DIP package in tube packaging and non RoHS compliant.

Option data sheets are available. Contact your Broadcom sales representative or authorized distributor for information.

NOTE: The notation “#XXX” is used for existing products, while (new) products launched since July 15, 2001 and RoHS compliant option use “-XXXE.”

Package Outline Drawings

Standard DIP Package

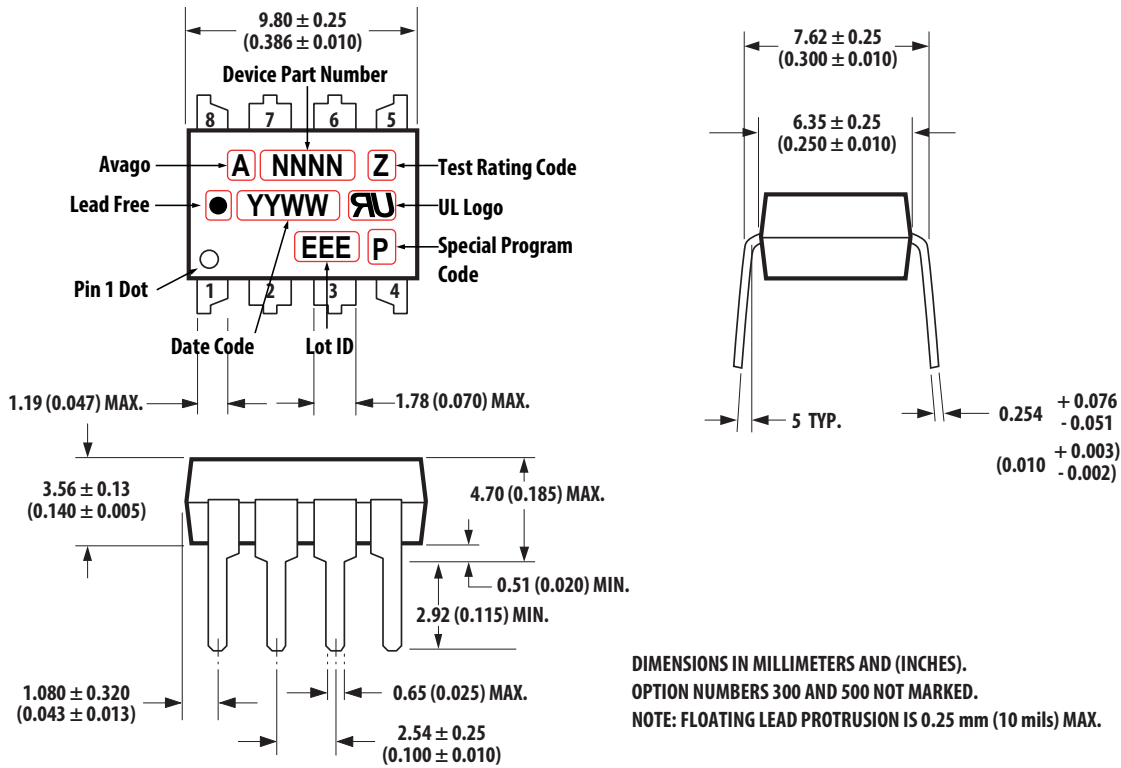

Gull-Wing Surface-Mount Option 300

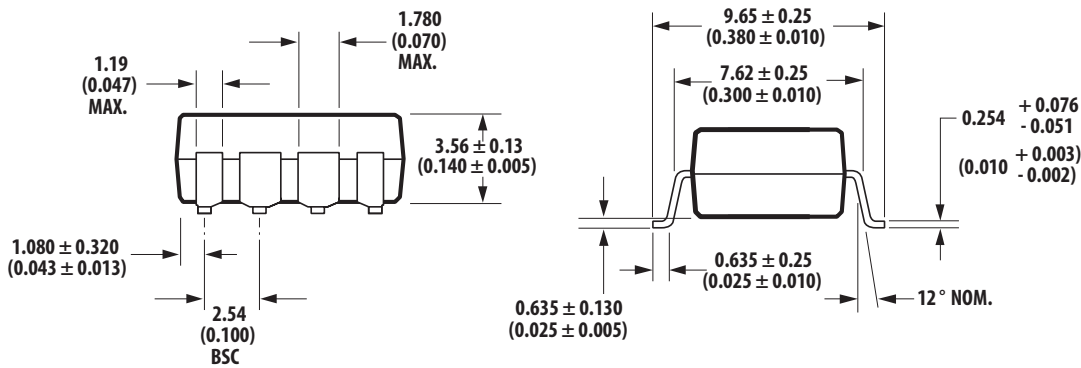

DIMENSIONS IN MILLIMETERS (INCHES).
 LEAD COPLANARITY = 0.10 mm (0.004 INCHES).
 NOTE: FLOATING LEAD PROTRUSION IS 0.5 mm (20 mils) MAX.

16-Lead Surface Mount Package

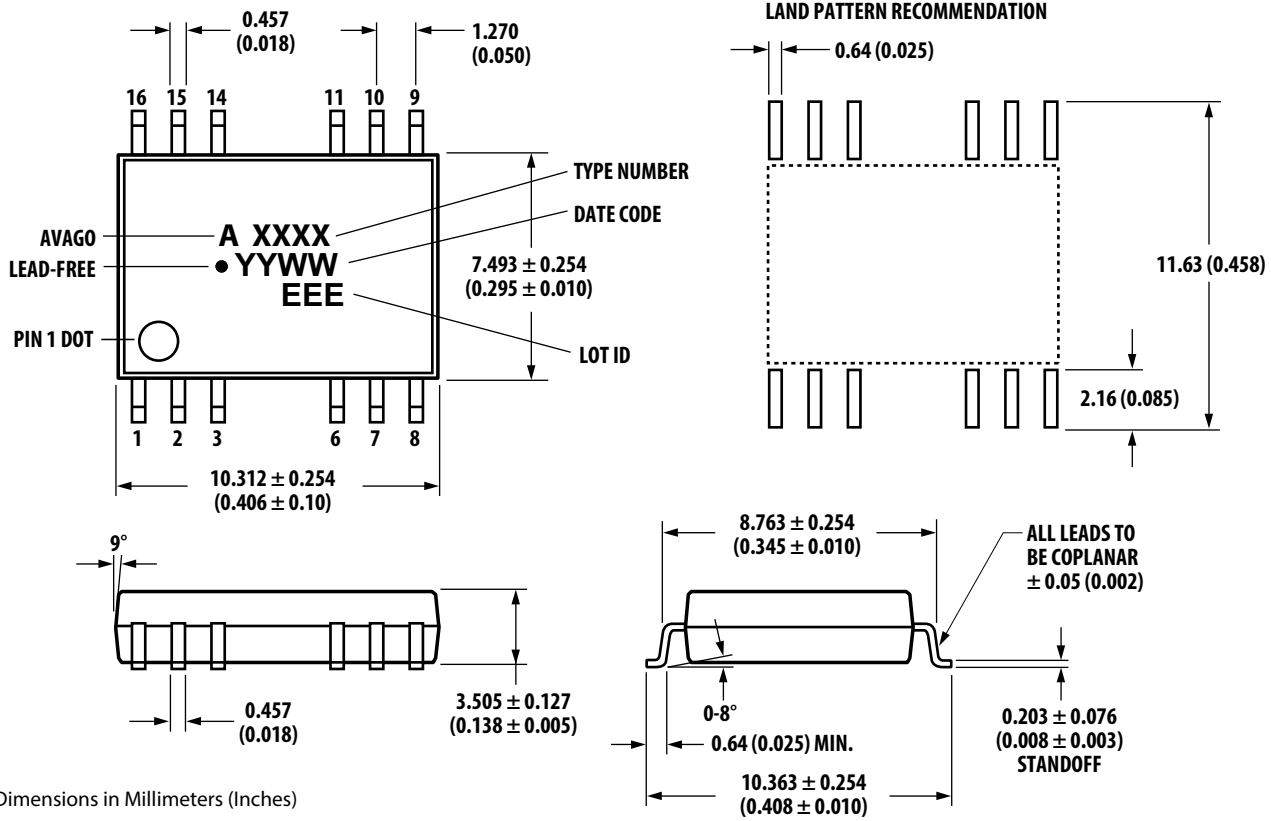

Dimensions in Millimeters (Inches)

Floating lead protrusion is 0.25 mm (10 mils) Max.

Note: Initial and continued variation in color of the white mold compound is normal and does not affect performance or reliability of the device

Recommended Pb-Free IR Profile

Recommended reflow condition as per JEDEC Standard, J-STD-020 (latest revision). Non-halide flux should be used.

Regulatory Information

The HCPL-3150 and HCPL-315J have been approved by the following organizations.

| | |
|--------------------------------|--|
| UL | Recognized under UL 1577, Component Recognition Program, File E55361. |
| CSA | Approved under CSA Component Acceptance Notice #5, File CA 88324. |
| IEC/EN/DIN EN 60747-5-5 | Approved under: DIN EN 60747-5-5(VDE 0884-5):2011-11 (Option 060 and HCPL-315J only) |

IEC/EN/DIN EN 60747-5-5 Insulation Characteristics

| Description | Symbol | HCPL-3150#060 | HCPL-315J | Units |
|---|-----------------|---------------|-------------------------------------|----------|
| Installation classification per DIN VDE 0110/1.89, Table 1 For rated mains voltage ≤ 150 Vrms For rated mains voltage ≤ 300 Vrms For rated mains voltage ≤ 600 Vrms For rated mains voltage ≤ 1000 Vrms | | | I - IV I - IV I - IV I-III | |
| Climatic Classification | | 55/100/21 | 55/100/21 | |
| Pollution Degree (DIN VDE 0110/1.89) | | 2 | 2 | |
| Maximum Working Insulation Voltage | V_{IORM} | 630 | 1414 | Vpeak |
| Input to Output Test Voltage, Method b ^a $V_{IORM} \times 1.875 = V_{PR}$, 100% Production Test with $t_m = 1$ second, Partial discharge < 5 pC | V_{PR} | 1181 | 2652 | Vpeak |
| Input to Output Test Voltage, Method a ^a $V_{IORM} \times 1.6 = V_{PR}$, Type and Sample Test, $t_m = 10$ seconds, Partial discharge < 5 pC | V_{PR} | 945 | 2262 | Vpeak |
| Highest Allowable Overvoltage ^a (Transient Overvoltage $t_{ini} = 60$ seconds) | V_{IOTM} | 6000 | 8000 | Vpeak |
| Safety-Limiting Values – Maximum Values Allowed in the Event of a Failure, Also See Figure 41 and Figure 42 . | | | | |
| Case Temperature | T_S | 175 | 175 | °C |
| Input Current | $I_{S, INPUT}$ | 230 | 400 | mA |
| Output Power | $P_{S, OUTPUT}$ | 600 | 1200 | mW |
| Insulation Resistance at T_S , $V_{IO} = 500V$ | R_S | $\geq 10^9$ | $\geq 10^9$ | Ω |

a. Refer to IEC/EN/DIN EN 60747-5-5 Optoisolator Safety Standard section of the Broadcom Regulatory Guide to Isolation Circuits, AV02-2041EN for a detailed description of Method a and Method b partial discharge test profiles.

NOTE: Isolation characteristics are guaranteed only within the safety maximum ratings that must be ensured by protective circuits in application.

Insulation and Safety Related Specifications

| Parameter | Symbol | HCPL-3150 | HCPL-315J | Units | Conditions |
|---|--------|-----------|-----------|-------|---|
| Minimum External Air Gap (External Clearance) | L(101) | 7.1 | 8.3 | mm | Measured from input terminals to output terminals, shortest distance through air. |
| Minimum External Tracking (External Creepage) | L(102) | 7.4 | 8.3 | mm | Measured from input terminals to output terminals, shortest distance path along body. |
| Minimum Internal Plastic Gap (Internal Clearance) | | 0.08 | ≥ 0.5 | mm | Through insulation distance conductor to conductor. |
| Tracking Resistance (Comparative Tracking Index) | CTI | ≥ 175 | ≥ 175 | Volts | DIN IEC 112/VDE 0303 Part 1 |
| Isolation Group | | IIIa | IIIa | | Material Group (DIN VDE 0110, 1/89, Table 1) |

Option 300 – surface mount classification is Class A in accordance with CECC 00802.

Absolute Maximum Ratings

| Parameter | Symbol | Min. | Max. | Units | Note |
|---|--|------|----------|-------|------|
| Storage Temperature | T_S | -55 | 125 | °C | |
| Operating Temperature | T_A | -40 | 100 | °C | |
| Average Input Current | $I_{F(AVG)}$ | — | 25 | mA | a, b |
| Peak Transient Input Current (<1- μ s pulse width, 300 pps) | $I_{F(TRAN)}$ | — | 1.0 | A | |
| Reverse Input Voltage | V_R | — | 5 | Volts | |
| “High” Peak Output Current | $I_{OH(PEAK)}$ | — | 0.6 | A | b, c |
| “Low” Peak Output Current | $I_{OL(PEAK)}$ | — | 0.6 | A | b, c |
| Supply Voltage | $(V_{CC} - V_{EE})$ | 0 | 35 | Volts | |
| Output Voltage | $V_{O(PEAK)}$ | 0 | V_{CC} | Volts | |
| Output Power Dissipation | P_O | — | 250 | mW | b, d |
| Total Power Dissipation | P_T | — | 295 | mW | b, e |
| Lead Solder Temperature | 260°C for 10 seconds, 1.6 mm below seating plane | | | | |
| Solder Reflow Temperature Profile | See Package Outline Drawings Section | | | | |

- Derate linearly above 70°C free-air temperature at a rate of 0.3 mA/°C.
- Each channel.
- Maximum pulse width = 10 μ s, maximum duty cycle = 0.2%. This value is intended to allow for component tolerances for designs with I_O peak minimum = 0.5A. See the Applications section for additional details on limiting I_{OH} peak.
- Derate linearly above 70°C free-air temperature at a rate of 4.8 mW/°C.
- Derate linearly above 70°C free-air temperature at a rate of 5.4 mW/°C. The maximum LED junction temperature should not exceed 125°C.

Recommended Operating Conditions

| Parameter | Symbol | Min. | Max. | Units |
|-----------------------|---------------------|------|------|-------|
| Power Supply Voltage | $(V_{CC} - V_{EE})$ | 15 | 30 | V |
| Input Current (ON) | $I_{F(ON)}$ | 7 | 16 | mA |
| Input Voltage (OFF) | $V_{F(OFF)}$ | -3.6 | 0.8 | V |
| Operating Temperature | T_A | -40 | 100 | °C |

Electrical Specifications (DC)

Over recommended operating conditions ($T_A = -40^\circ\text{C}$ to 100°C , $I_{F(\text{ON})} = 7\text{ mA}$ to 16 mA , $V_{F(\text{OFF})} = -3.6\text{V}$ to 0.8V , $V_{CC} = 15\text{V}$ to 30V , $V_{EE} = \text{Ground}$, each channel) unless otherwise specified.

| Parameter | Symbol | Min. | Typ. ^a | Max. | Units | Test Conditions | Figure | Note |
|--|-------------------------|----------------|-------------------|------|-------|--|--------------|------|
| High Level Output Current | I_{OH} | 0.1 | 0.4 | — | A | $V_O = (V_{CC} - 4\text{V})$ | 2, 3, 5 | |
| | | 0.5 | — | — | | $V_O = (V_{CC} - 15\text{V})$ | 17 | b |
| Low Level Output Current | I_{OL} | 0.1 | 0.6 | — | A | $V_O = (V_{EE} + 2.5\text{V})$ | 5, 6 | c |
| | | 0.5 | — | — | | $V_O = (V_{EE} + 15\text{V})$ | 18 | b |
| High Level Output Voltage | V_{OH} | $(V_{CC} - 4)$ | $(V_{CC} - 3)$ | — | V | $I_O = -100\text{ mA}$ | 1, 3, 19 | d, e |
| Low Level Output Voltage | V_{OL} | — | 0.4 | 1.0 | V | $I_O = 100\text{ mA}$ | 4, 6, 20 | |
| High Level Supply Current | I_{CCH} | — | 2.5 | 5.0 | mA | Output Open, $I_F = 7$ to 16 mA | 7, 8 | f |
| Low Level Supply Current | I_{CCL} | — | 2.7 | 5.0 | mA | Output Open, $V_F = -3.0$ to $+0.8\text{V}$ | | |
| Threshold Input Current Low to High | I_{FLH} | — | 2.2 | 5.0 | mA | HCPL-3150 | 9, 15, 21 | |
| | | — | 2.6 | 6.4 | | HCPL-315J | | |
| Threshold Input Voltage High to Low | V_{FHL} | 0.8 | — | — | V | | | |
| Input Forward Voltage | V_F | 1.2 | 1.5 | 1.8 | V | HCPL-3150 | 16 | |
| | | | 1.6 | 1.95 | V | HCPL-315J | | |
| Temperature Coefficient of Forward Voltage | $\Delta V_F/\Delta T_A$ | — | -1.6 | — | mV/°C | $I_F = 10\text{ mA}$ | | |
| Input Reverse Breakdown Voltage | BV_R | 5 | — | — | V | HCPL-3150 | | |
| | | 3 | | | V | HCPL-315J | | |
| Input Capacitance | C_{IN} | — | 70 | — | pF | $f = 1\text{ MHz}$, $V_F = 0\text{V}$ | | |
| UVLO Threshold | V_{UVLO+} | 11.0 | 12.3 | 13.5 | V | $V_O > 5\text{ V}$ | 22, 40 | |
| | V_{UVLO-} | 9.5 | 10.7 | 12.0 | | $I_F = 10\text{ mA}$ | | |
| UVLO Hysteresis | $UVLO_{HYS}$ | — | 1.6 | — | V | | | |

- All typical values at $T_A = 25^\circ\text{C}$ and $V_{CC} - V_{EE} = 30\text{V}$, unless otherwise noted.
- Maximum pulse width = $10\text{ }\mu\text{s}$, maximum duty cycle = 0.2%. This value is intended to allow for component tolerances for designs with I_O peak minimum = 0.5 A. See Applications section for additional details on limiting I_{OH} peak.
- Maximum pulse width = $50\text{ }\mu\text{s}$, maximum duty cycle = 0.5%.
- In this test, V_{OH} is measured with a dc load current. When driving capacitive loads V_{OH} will approach V_{CC} as I_{OH} approaches zero amps.
- Maximum pulse width = 1 ms, maximum duty cycle = 20%.
- Each channel.

Switching Specifications (AC)

Over recommended operating conditions ($T_A = -40$ to 100°C , $I_{F(ON)} = 7$ mA to 16 mA, $V_{F(OFF)} = -3.6$ V to 0.8 V, $V_{CC} = 15$ V to 30 V, $V_{EE} = \text{Ground}$, each channel) unless otherwise specified.

| Parameter | Symbol | Min. | Typ. ^a | Max. | Units | Test Conditions | Figure | Note | |
|--|--------------------------------|-------|-------------------|------|-------------------|--|------------------------------|--------|---|
| Propagation Delay Time to High Output Level | t_{PLH} | 0.10 | 0.30 | 0.50 | μs | $R_g = 47 \Omega$, $C_g = 3 \text{ nF}$, $f = 10 \text{ kHz}$, Duty Cycle = 50% | 10, 11, 12, 13, 14, 23 | b | |
| Propagation Delay Time to Low Output Level | t_{PHL} | 0.10 | 0.3 | 0.50 | μs | | | | |
| Pulse Width Distortion | PWD | | | 0.3 | μs | | | | |
| Propagation Delay Difference Between Any Two Parts or Channels | PDD ($t_{PHL} - t_{PLH}$) | -0.35 | — | 0.35 | μs | | | 38, 39 | d |
| Rise Time | t_r | — | 0.1 | — | μs | | | 23 | |
| Fall Time | t_f | — | 0.1 | — | μs | | | | |
| UVLO Turn On Delay | $t_{UVLO ON}$ | — | 0.8 | — | μs | $V_O > 5\text{V}$, $I_F = 10 \text{ mA}$ | 22 | | |
| UVLO Turn Off Delay | $t_{UVLO OFF}$ | — | 0.6 | — | μs | $V_O < 5\text{V}$, $I_F = 10 \text{ mA}$ | | | |
| Output High Level Common Mode Transient Immunity | $ CM_H $ | 15 | 30 | — | kV/ μs | $T_A = 25^\circ\text{C}$, $I_F = 10$ to 16 mA, $V_{CM} = 1500\text{V}$, $V_{CC} = 30 \text{ V}$ | 24 | e, f | |
| Output Low Level Common Mode Transient Immunity | $ CM_L $ | 15 | 30 | — | kV/ μs | $T_A = 25^\circ\text{C}$, $V_{CM} = 1500\text{V}$, $V_F = 0 \text{ V}$, $V_{CC} = 30\text{V}$ | | e, g | |

- All typical values at $T_A = 25^\circ\text{C}$ and $V_{CC} - V_{EE} = 30\text{V}$, unless otherwise noted.
- This load condition approximates the gate load of a 1200 V/25 A IGBT
- Pulse Width Distortion (PWD) is defined as $|t_{PHL} - t_{PLH}|$ for any given device.
- The difference between t_{PHL} and t_{PLH} between any two parts or channels under the same test condition.
- Pins 1 and 4 (HCPL-3150) and pins 3 and 4 (HCPL-315J) need to be connected to LED common.
- Common mode transient immunity in the high state is the maximum tolerable $|dV_{CM}/dt|$ of the common mode pulse, V_{CM} , to assure that the output will remain in the high state (that is, $V_O > 15.0\text{V}$).
- Common mode transient immunity in a low state is the maximum tolerable $|dV_{CM}/dt|$ of the common mode pulse, V_{CM} , to assure that the output will remain in a low state (that is, $V_O < 1.0\text{V}$).

Package Characteristics

Each channel, unless otherwise specified.

| Parameter | Symbol | Device | Min. | Typ. ^a | Max. | Units | Test Conditions | Figure | Note |
|--|---------------|-----------|------|-------------------|------|--------------------|---|--------|------|
| Input-Output Momentary Withstand Voltage ^b | V_{ISO} | HCPL-3150 | 3750 | — | — | Vrms | RH < 50%, t = 1 min., $T_A = 25^\circ\text{C}$ | | c, d |
| | | HCPL-315J | 5000 | | | | | | |
| Output-Output Momentary Withstand Voltage ^b | V_{O-O} | HCPL-315J | 1500 | — | — | Vrms | RH < 50%, t = 1 min., $T_A = 25^\circ\text{C}$ | | e |
| Resistance (Input-Output) | R_{I-O} | | — | 10^{12} | — | Ω | $V_{I-O} = 500 V_{DC}$ | | f |
| Capacitance (Input-Output) | C_{I-O} | HCPL-3150 | — | 0.6 | — | pF | f = 1 MHz | | |
| | | HCPL-315J | | 1.3 | | | | | |
| LED-to-Case Thermal Resistance | θ_{LC} | HCPL-3150 | — | 391 | — | $^\circ\text{C/W}$ | Thermocouple located at center underside of package | 29, 30 | g |
| LED-to-Detector Thermal Resistance | θ_{LD} | HCPL-3150 | — | 439 | — | $^\circ\text{C/W}$ | | | |
| Detector-to-Case Thermal Resistance | θ_{DC} | HCPL-3150 | — | 119 | — | $^\circ\text{C/W}$ | | | |

- a. All typical values at $T_A = 25^\circ\text{C}$ and $V_{CC} - V_{EE} = 30\text{V}$, unless otherwise noted.
- b. The Input-Output/Output-Output Momentary Withstand Voltage is a dielectric voltage rating that should not be interpreted as an input-output/output-output continuous voltage rating. For the continuous voltage rating, refer to your equipment level safety specification or Broadcom Application Note 1074, *Optocoupler Input-Output Endurance Voltage*.
- c. In accordance with UL1577, each HCPL-3150 optocoupler is proof tested by applying an insulation test voltage ≥ 4500 Vrms (≥ 6000 Vrms for the HCPL-315J) for 1 second. This test is performed before the 100% production test for partial discharge (method b) shown in the IEC/EN/DIN EN 60747-5-5 Insulation Characteristics Table, if applicable.
- d. Device considered a two-terminal device: pins on input side shorted together and pins on output side shorted together.
- e. Device considered a two terminal device: Channel one output side pins shorted together, and channel two output side pins shorted together.
- f. Device considered a two-terminal device: pins on input side shorted together and pins on output side shorted together.
- g. See the thermal model for the HCPL-315J in the application section of this data sheet.

Figure 1: V_{OH} vs. Temperature



Figure 2: I_{OH} vs. Temperature



Figure 3: V_{OH} vs. I_{OH}



Figure 4: V_{OL} vs. Temperature



Figure 5: I_{OL} vs. Temperature



Figure 6: V_{OL} vs. I_{OL}



Figure 7: I_{CC} vs. Temperature



Figure 8: I_{CC} vs. V_{CC}



Figure 9: I_{FLH} vs. Temperature

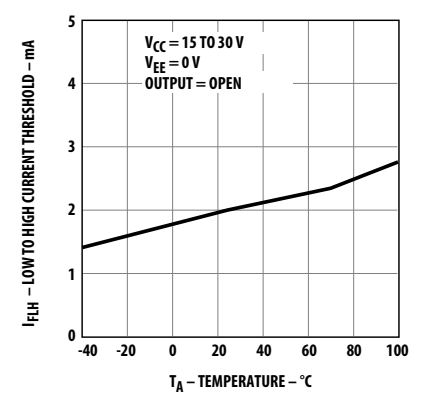

Figure 10: Propagation Delay vs. V_{CC}

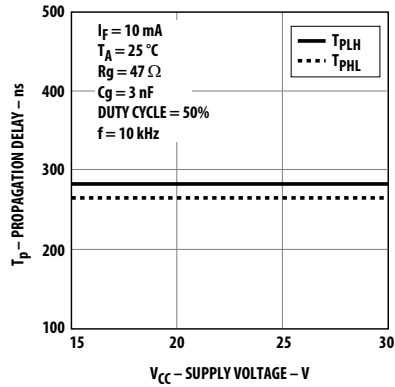

Figure 11: Propagation Delay vs. I_F



Figure 12: Propagation Delay vs. Temperature



Figure 13: Propagation Delay vs. R_g

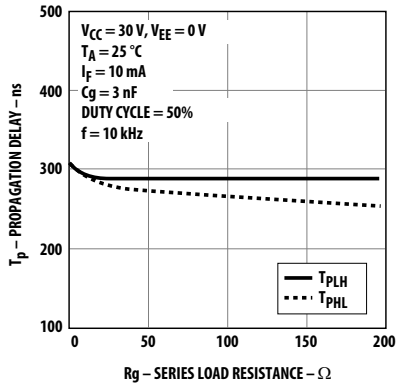

Figure 14: Propagation Delay vs. C_g

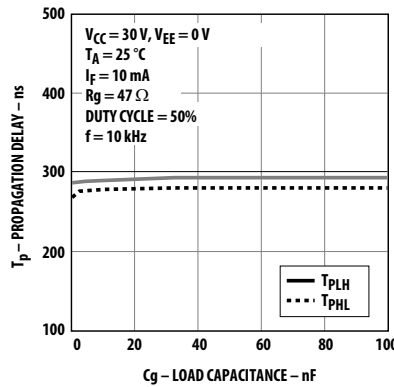

Figure 15: Transfer Characteristics

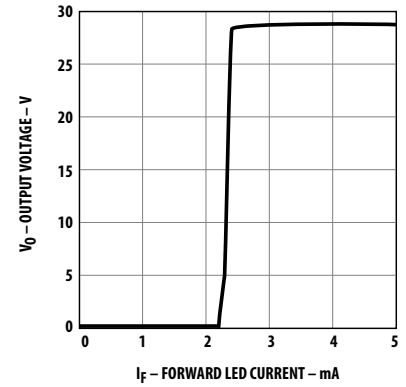

Figure 16: Input Current vs. Forward Voltage

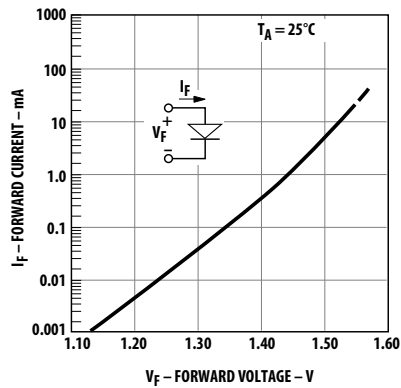

Figure 17: I_{OH} Test Circuit



Figure 18: I_{OL} Test Circuit



Figure 19: V_{OH} Test Circuit



Figure 20: V_{OL} Test Circuit



Figure 21: I_{FLH} Test Circuit



Figure 22: UVLO Test Circuit



Figure 23: t_{PLH} , t_{PHL} , t_r , and t_f Test Circuit and Waveforms

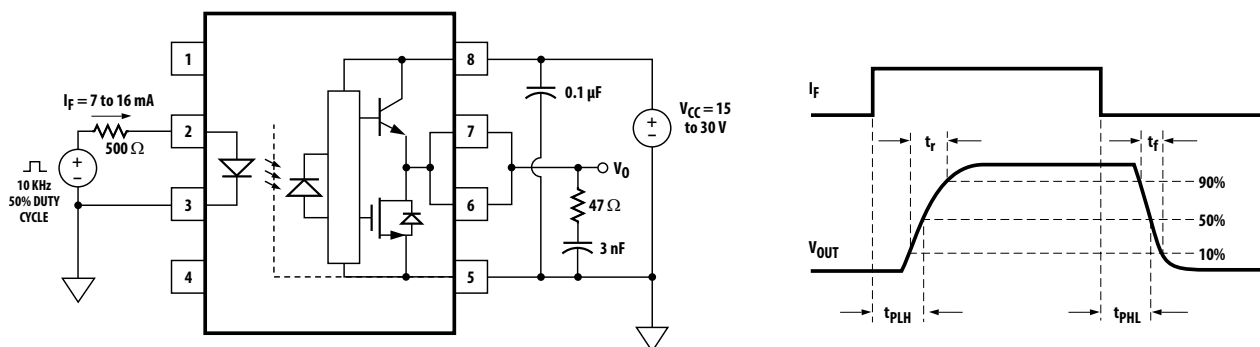
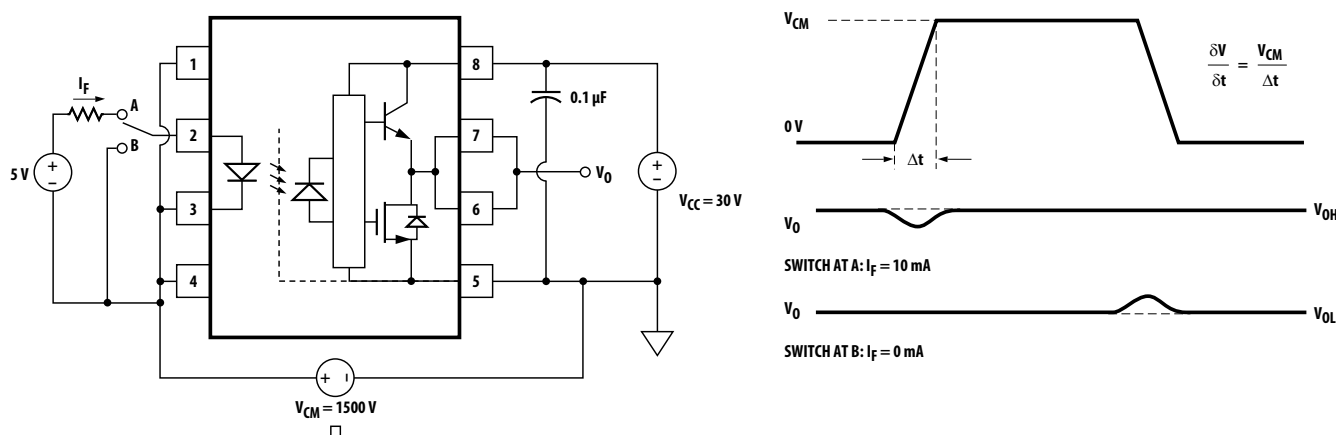

Figure 24: CMR Test Circuit and Waveforms



Applications Information

Eliminating Negative IGBT Gate Drive

To keep the IGBT firmly off, the HCPL-3150/315J has a very low maximum V_{OL} specification of 1.0V. The HCPL-3150/315J realizes this very low V_{OL} by using a DMOS transistor with 4Ω (typical) on resistance in its pull-down circuit. When the HCPL3150/315J is in the low state, the IGBT gate is shorted to the emitter by $R_g + 4\Omega$. Minimizing R_g and the lead inductance from the HCPL-3150/315J to the IGBT gate and emitter (possibly by mounting the HCPL-3150/315J on a small PC board directly above the IGBT) can eliminate the need for negative IGBT gate drive in many applications as shown in [Figure 25](#) and [Figure 26](#). Care should be taken with such a PC board design to avoid routing the IGBT collector or emitter traces close to the HCPL-3150/315J and degrade performance. (If the IGBT drain must be routed near the HCPL-3150/315J input, then the LED should be reverse-biased when in the off state, to prevent the transient signals coupled from the IGBT drain from turning on the HCPL-3150/315J.)

Figure 25: Recommended LED Drive and Application Circuit



Figure 26: Recommended LED Drive and Application Circuit (HCPL-315J)



Selecting the Gate Resistor (Rg) to Minimize IGBT Switching Losses

Step 1: Calculate Rg Minimum From the IOL Peak Specification. The IGBT and Rg in Figure 27 and Figure 28 can be analyzed as a simple RC circuit with a voltage supplied by the HCPL-3150/315J.

$$\begin{aligned} R_g &\geq \frac{(V_{CC} - V_{EE} - V_{OL})}{I_{OLPEAK}} \\ &= \frac{(V_{CC} - V_{EE} - 1.7 V)}{I_{OLPEAK}} \\ &= \frac{(15 V + 5 V - 1.7 V)}{0.6 A} \\ &= 30.5 \Omega \end{aligned}$$

The V_{OL} value of 2V in the previous equation is a conservative value of V_{OL} at the peak current of 0.6A (see Figure 6). At lower Rg values the voltage supplied by the HCPL-3150/315J is not an ideal voltage step. This results in lower peak currents (more margin) than predicted by this analysis. When negative gate drive is not used V_{EE} in the previous equation is equal to zero volts.

Step 2: Check the HCPL-3150/315J Power Dissipation and Increase Rg if Necessary. The HCPL-3150/315J total power dissipation (P_T) is equal to the sum of the emitter power (P_E) and the output power (P_O):

$$\begin{aligned} P_T &= P_E + P_O \\ P_E &= I_F \cdot V_F \cdot \text{Duty Cycle} \\ P_O &= P_{O(BIAS)} + P_{O(SWITCHING)} \\ &= I_{CC} \cdot (V_{CC} - V_{EE}) + E_{SW} (R_G Q_G) \cdot f \end{aligned}$$

For the circuit in Figure 27 and Figure 28 with I_F (worst case) = 16 mA, $R_g = 30.5\Omega$, Max Duty Cycle = 80%, $Q_g = 500$ nC, $f = 20$ kHz, and $T_{Amax} = 90^\circ\text{C}$:

$$\begin{aligned} P_E &= 16 \text{ mA} \cdot 1.8 \text{ V} \cdot 0.8 = 23 \text{ mW} \\ P_O &= 4.25 \text{ mA} \cdot 20 \text{ V} + 4.0 \mu\text{J} \cdot 20 \text{ kHz} \\ &= 85 \text{ mW} + 80 \text{ mW} \\ &= 165 \text{ mW} > 154 \text{ mW} (P_{O(MAX)} @ 90^\circ\text{C}) \\ &= 250 \text{ mW} - 20\text{C} \cdot 4.8 \text{ mW/C} \end{aligned}$$

Figure 27: HCPL-3150 Typical Application Circuit with Negative IGBT Gate Drive

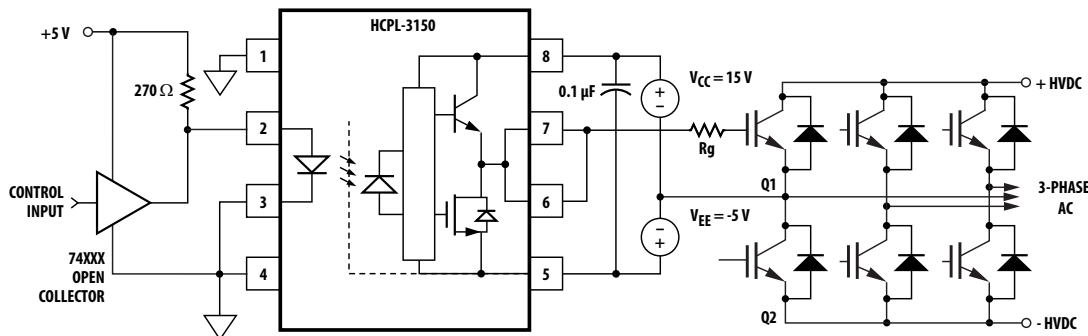

Figure 28: HCPL-315J Typical Application Circuit with Negative IGBT Gate Drive



Table 1: P_E and P_O Parameters

| P_E Parameter | Description | P_O Parameter | Description |
|-----------------|------------------------|--------------------|---|
| I_F | LED Current | I_{CC} | Supply Current |
| V_F | LED On Voltage | V_{CC} | Positive Supply Voltage |
| Duty Cycle | Maximum LED Duty Cycle | V_{EE} | Negative Supply Voltage |
| | | $E_{SW}(R_g, Q_g)$ | Energy Dissipated in the HCPL-3150/315J for each IGBT Switching Cycle (see Figure 32) |
| | | f | Switching Frequency |

The value of 4.25 mA for I_{CC} in the previous equation was obtained by derating the I_{CC} max of 5 mA (which occurs at -40°C) to I_{CC} max at 90°C (see Figure 7).

Since P_O for this case is greater than $P_{O(MAX)}$, R_g must be increased to reduce the HCPL-3150 power dissipation.

$$\begin{aligned} P_{O(SWITCHING\ MAX)} &= P_{O(MAX)} - P_{O(BIAS)} \\ &= 154\text{ mW} - 85\text{ mW} \\ &= 69\text{ mW} \end{aligned}$$

$$\begin{aligned} E_{SW(MAX)} &= \frac{P_{O(SWITCHING\ MAX)}}{f} \\ &= \frac{69\text{ mW}}{20\text{ kHz}} = 3.45\ \mu\text{J} \end{aligned}$$

For $Q_g = 500\text{ nC}$, from Table 1, a value of $E_{SW} = 3.45\ \mu\text{J}$ gives a $R_g = 41\ \Omega$.

Figure 29: Thermal Model

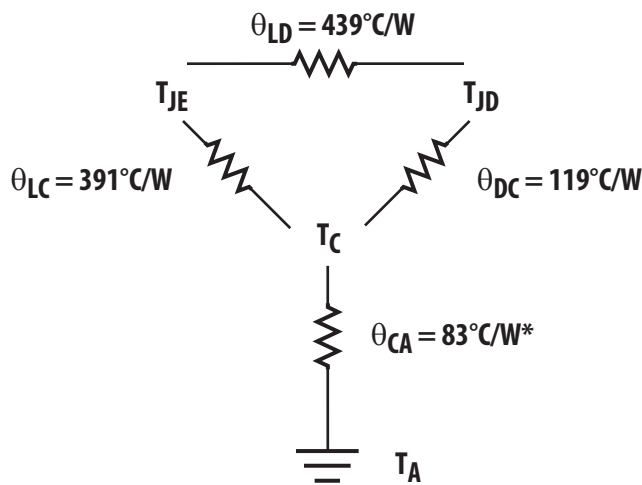

T_{JE} = LED JUNCTION TEMPERATURE
 T_{JD} = DETECTOR IC JUNCTION TEMPERATURE
 T_C = CASE TEMPERATURE MEASURED AT THE CENTER OF THE PACKAGE BOTTOM
 θ_{LC} = LED-TO-CASE THERMAL RESISTANCE
 θ_{LD} = LED-TO-DETECTOR THERMAL RESISTANCE
 θ_{DC} = DETECTOR-TO-CASE THERMAL RESISTANCE
 θ_{CA} = CASE-TO-AMBIENT THERMAL RESISTANCE
*** θ_{CA} WILL DEPEND ON THE BOARD DESIGN AND THE PLACEMENT OF THE PART.**

Thermal Model (HCPL-3150)

The steady state thermal model for the HCPL-3150 is shown in Figure 29. The thermal resistance values given in this model can be used to calculate the temperatures at each node for a given operating condition. As shown by the model, all heat generated flows through θ_{CA} which raises the case temperature T_C accordingly. The value of θ_{CA} depends on the conditions of the board design and is, therefore, determined by the designer. The value of $\theta_{CA} = 83^{\circ}\text{C/W}$ was obtained from thermal measurements using a 2.5 in. \times 2.5 in. PC board, with small traces (no ground plane), a single HCPL-3150 soldered into the center of the board and still air. The absolute maximum power dissipation derating specifications assume a θ_{CA} value of 83°C/W .

From the thermal mode in Figure 29, the LED and detector IC junction temperatures can be expressed as:

$$T_{JE} = P_E \cdot (\theta_{LC} \parallel (\theta_{LD} + \theta_{DC}) + \theta_{CA}) + P_D \cdot \left(\frac{\theta_{LC} \cdot \theta_{DC}}{\theta_{LC} + \theta_{DC} + \theta_{LD}} + \theta_{CA} \right) + T_A$$

$$T_{JD} = P_E \cdot \left(\frac{\theta_{LC} \cdot \theta_{DC}}{\theta_{LC} + \theta_{DC} + \theta_{LD}} + \theta_{CA} \right) + P_D \cdot (\theta_{DC} \parallel (\theta_{LD} + \theta_{LC}) + \theta_{CA}) + T_A$$

Inserting the values for θ_{LC} and θ_{DC} shown in Figure 29 gives:

$$T_{JE} = P_E \cdot (230^\circ\text{C/W} + \theta_{CA}) + P_D \cdot (49^\circ\text{C/W} + \theta_{CA}) + T_A$$

$$T_{JD} = P_E \cdot (49^\circ\text{C/W} + \theta_{CA}) + P_D \cdot (104^\circ\text{C/W} + \theta_{CA}) + T_A$$

For example, given $P_E = 45 \text{ mW}$, $P_O = 250 \text{ mW}$, $T_A = 70^\circ\text{C}$ and $\theta_{CA} = 83^\circ\text{C/W}$:

$$T_{JE} = P_E \cdot 313^\circ\text{C/W} + P_D \cdot 132^\circ\text{C/W} + T_A$$

$$= 45 \text{ mW} \cdot 313^\circ\text{C/W} + 250 \text{ mW} \cdot 132^\circ\text{C/W} + 70^\circ\text{C} = 117^\circ\text{C}$$

$$T_{JD} = P_E \cdot 132^\circ\text{C/W} + P_D \cdot 187^\circ\text{C/W} + T_A$$

$$= 45 \text{ mW} \cdot 132^\circ\text{C/W} + 250 \text{ mW} \cdot 187^\circ\text{C/W} + 70^\circ\text{C} = 123^\circ\text{C}$$

T_{JE} and T_{JD} should be limited to 125°C based on the board layout and part placement (θ_{CA}) specific to the application.

Thermal Model Dual-Channel (SOIC-16) HCPL-315J Optoisolator

Definitions

$\theta_1, \theta_2, \theta_3, \theta_4, \theta_5, \theta_6, \theta_7, \theta_8, \theta_9, \theta_{10}$: Thermal impedances between nodes as shown in Figure 30. Ambient Temperature: Measured approximately 1.25 cm above the optocoupler with no forced air.

Figure 30: Thermal Impedance Model for HCPL-315J

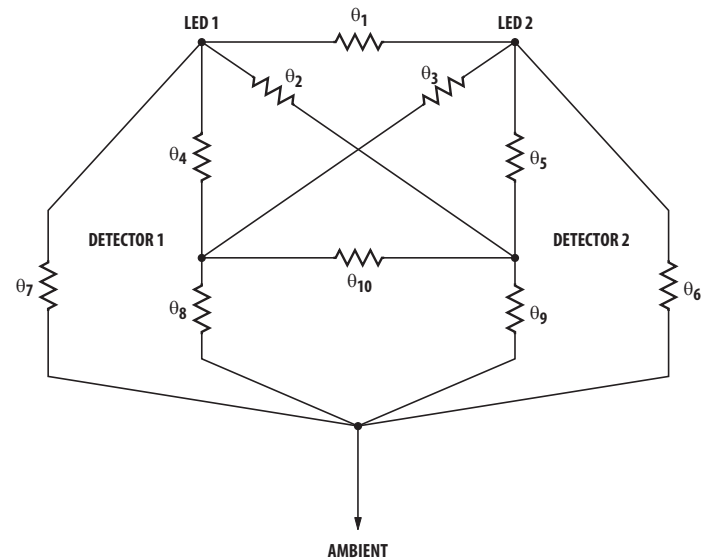
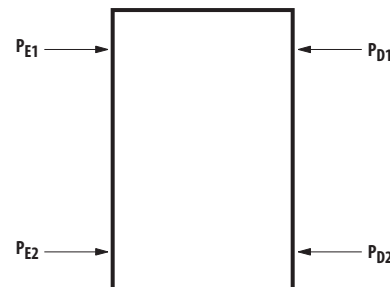

Figure 31: Power Dissipation



Description

This thermal model assumes that a 16-pin dual-channel (SOIC-16) optocoupler is soldered into an 8.5 cm x 8.1 cm printed circuit board (PCB). These optocouplers are hybrid devices with four die: two LEDs and two detectors. The temperature at the LED and the detector of the optocoupler can be calculated by using the equations below.

$$\Delta T_{E1A} = A_{11} P_{E1} + A_{12} P_{E2} + A_{13} P_{D1} + A_{14} P_{D2}$$

$$\Delta T_{E2A} = A_{21} P_{E1} + A_{22} P_{E2} + A_{23} P_{D1} + A_{24} P_{D2}$$

$$\Delta T_{D1A} = A_{31} P_{E1} + A_{32} P_{E2} + A_{33} P_{D1} + A_{34} P_{D2}$$

$$\Delta T_{D2A} = A_{41} P_{E1} + A_{42} P_{E2} + A_{43} P_{D1} + A_{44} P_{D2}$$

where:

ΔT_{E1A} = Temperature difference between ambient and LED 1

ΔT_{E2A} = Temperature difference between ambient and LED 2

ΔT_{D1A} = Temperature difference between ambient and detector 1

ΔT_{D2A} = Temperature difference between ambient and detector 2

P_{E1} = Power dissipation from LED 1;

P_{E2} = Power dissipation from LED 2;

P_{D1} = Power dissipation from detector 1;

P_{D2} = Power dissipation from detector 2

A_{xy} thermal coefficient (units in °C/W) is a function of thermal impedances θ_1 through θ_{10} .

Table 2: Thermal Coefficient Data (units in °C/W)

| Part Number | A_{11}, A_{22} | A_{12}, A_{21} | A_{13}, A_{31} | A_{24}, A_{42} | A_{14}, A_{41} | A_{23}, A_{32} | A_{33}, A_{44} | A_{34}, A_{43} |
|-------------|------------------|------------------|------------------|------------------|------------------|------------------|------------------|------------------|
| HCPL-315J | 198 | 64 | 62 | 64 | 83 | 90 | 137 | 69 |

NOTE: Maximum junction temperature for above part: 125°C.

LED Drive Circuit Considerations for Ultra High CMR Performance

Without a detector shield, the dominant cause of optocoupler CMR failure is capacitive coupling from the input side of the optocoupler, through the package, to the detector IC as shown in Figure 33. The HCPL-3150/315J improves CMR performance by using a detector IC with an optically transparent Faraday shield, which diverts the capacitively coupled current away from the sensitive IC circuitry. However, this shield does not eliminate the capacitive coupling between the LED and optocoupler pins 5 to 8 as shown in Figure 34. This capacitive coupling causes perturbations in the LED current during common mode transients and becomes the major source of CMR failures for a shielded optocoupler. The main design objective of a high CMR LED drive circuit becomes keeping the LED in the proper state (on or off) during common mode transients. For example, the recommended application circuit (Figure 25 and Figure 26), can achieve 15kV/μs CMR while minimizing component complexity.

Techniques to keep the LED in the proper state are discussed in the next two sections.

CMR with the LED On (CMR_H)

A high CMR LED drive circuit must keep the LED on during common mode transients. This is achieved by overdriving the LED current beyond the input threshold so that it is not pulled below the threshold during a transient. A minimum LED current of 10 mA provides adequate margin over the maximum I_{FLH} of 5 mA to achieve 15kV/μs CMR.

Figure 32: Energy Dissipated in the HCPL-3150 for Each IGBT Switching Cycle.



CMR with the LED Off (CMR_L)

A high CMR LED drive circuit must keep the LED off ($V_F \leq V_{F(OFF)}$) during common mode transients. For example, during a $-dV_{CM}/dt$ transient in Figure 35, the current flowing through C_{LEDP} also flows through the R_{SAT} and V_{SAT} of the logic gate. As long as the low state voltage developed across the logic gate is less than $V_{F(OFF)}$, the LED will remain off and no common mode failure will occur.

The open collector drive circuit, shown in Figure 36, cannot keep the LED off during a $+dV_{CM}/dt$ transient, since all the current flowing through C_{LEDN} must be supplied by the LED, and it is not recommended for applications requiring ultra-high CMR_L performance. Figure 37 is an alternative drive circuit which, like the recommended application circuit (Figure 25 and Figure 26), does achieve ultra-high CMR performance by shunting the LED in the off state.

Under Voltage Lockout Feature

The HCPL-3150/315J contains an under voltage lockout (UVLO) feature that is designed to protect the IGBT under fault conditions that cause the HCPL-3150/315J supply voltage (equivalent to the fully-charged IGBT gate voltage) to drop below a level necessary to keep the IGBT in a low resistance state. When the HCPL-3150/315J output is in the high state and the supply voltage drops below the HCPL-3150/315J V_{UVLO-} threshold ($9.5 < V_{UVLO-} < 12.0$), the optocoupler output will go into the low state with a typical delay, UVLO Turn Off Delay, of 0.6 μs. When the HCPL-3150/315J output is in the low state and the supply voltage rises above the HCPL-3150/315J V_{UVLO+} threshold ($11.0 < V_{UVLO+} < 13.5$), the optocoupler will go into the high state (assuming LED is "ON") with a typical delay, UVLO TURN On Delay, of 0.8 μs.

IPM Dead Time and Propagation Delay Specifications

The HCPL-3150/315J includes a Propagation Delay Difference (PDD) specification intended to help designers minimize “dead time” in their power inverter designs. Dead time is the time period during which both the high and low side power transistors (Q1 and Q2 in Figure 38) are off. Any overlap in Q1 and Q2 conduction will result in large currents flowing through the power devices from the high- to the low-voltage motor rails.

To minimize dead time in a given design, the turn on of LED2 should be delayed (relative to the turn off of LED1) so that under worst-case conditions, transistor Q1 has just turned off when transistor Q2 turns on, as shown in Figure 38. The amount of delay necessary to achieve this condition is equal to the maximum value of the propagation delay difference specification, PDD_{MAX} , which is specified to be 350 ns over the operating temperature range of -40°C to 100°C .

Figure 33: Optocoupler Input to Output Capacitance Model for Unshielded Optocouplers

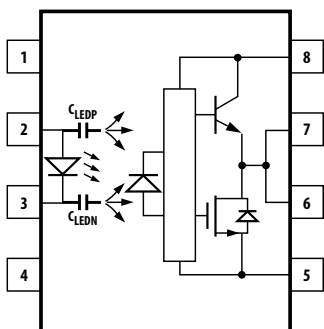

Delaying the LED signal by the maximum propagation delay difference ensures that the minimum dead time is zero, but it does not tell a designer what the maximum dead time will be. The maximum dead time is equivalent to the difference between the maximum and minimum propagation delay difference specifications as shown in Figure 39. The maximum dead time for the HCPL-3150/315J is 700 ns ($= 350 \text{ ns} - (-350 \text{ ns})$) over an operating temperature range of -40°C to 100°C .

Note that the propagation delays used to calculate PDD and dead time are taken at equal temperatures and test conditions since the optocouplers under consideration are typically mounted in close proximity to each other and are switching identical IGBTs.

Figure 34: Optocoupler Input to Output Capacitance Model for Shielded Optocouplers

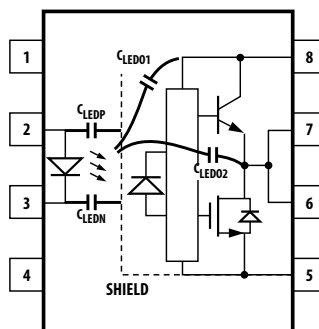

Figure 35: Equivalent Circuit for Figure 25 During Common Mode Transient

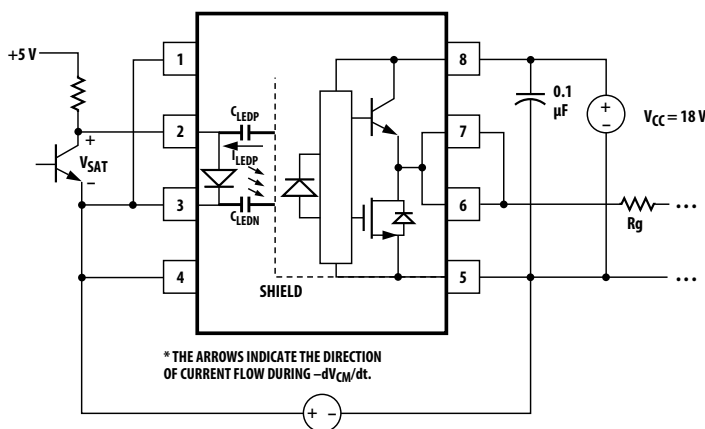

Figure 36: Not Recommended Open Collector Drive Circuit



Figure 37: Recommended LED Drive Circuit for Ultra-High CMR

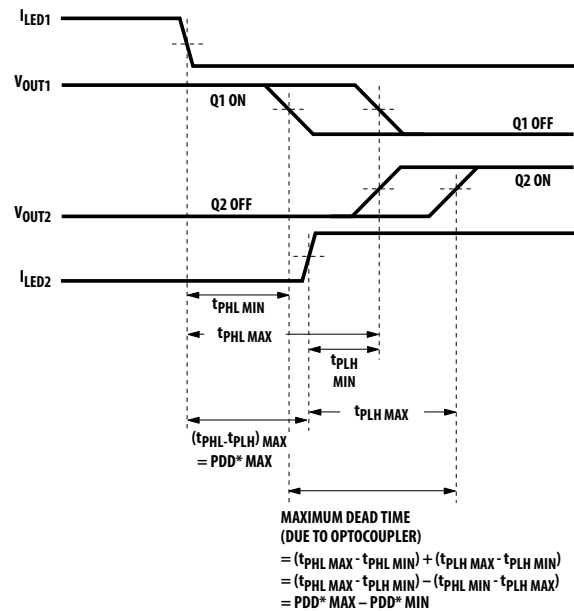

Figure 38: Minimum LED Skew for Zero Dead Time



*PDD = PROPAGATION DELAY DIFFERENCE
 NOTE: FOR PDD CALCULATIONS THE PROPAGATION DELAYS
 ARE TAKEN AT THE SAME TEMPERATURE AND TEST CONDITIONS.

Figure 39: Waveforms for Dead Time



*PDD = PROPAGATION DELAY DIFFERENCE
 NOTE: FOR DEAD TIME AND PDD CALCULATIONS ALL PROPAGATION
 DELAYS ARE TAKEN AT THE SAME TEMPERATURE AND TEST CONDITIONS.

Figure 40: Under Voltage Lock Out

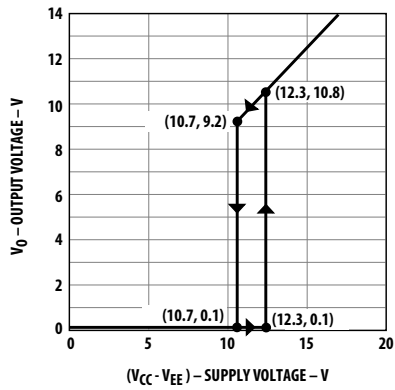

Figure 41: HCPL-3150: Thermal Derating Curve, Dependence of Safety Limiting Value with Case Temperature per IEC/EN/DIN EN 60747-5-5

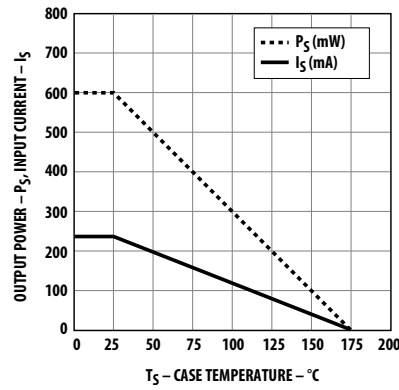
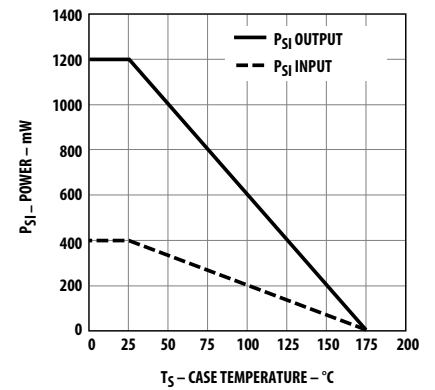

Figure 42: HCPL-315J: Thermal Derating Curve, Dependence of Safety Limiting Value with Case Temperature per IEC/EN/DIN EN 60747-5-5



Broadcom, the pulse logo, Connecting everything, Avago Technologies, Avago, and the A logo are among the trademarks of Broadcom and/or its affiliates in the United States, certain other countries and/or the EU.

Copyright © 2015–2017 by Broadcom. All Rights Reserved.

The term “Broadcom” refers to Broadcom Limited and/or its subsidiaries. For more information, please visit www.broadcom.com.

Broadcom reserves the right to make changes without further notice to any products or data herein to improve reliability, function, or design. Information furnished by Broadcom is believed to be accurate and reliable. However, Broadcom does not assume any liability arising out of the application or use of this information, nor the application or use of any product or circuit described herein, neither does it convey any license under its patent rights nor the rights of others.





Стандарт Электрон Связь

Мы молодая и активно развивающаяся компания в области поставок электронных компонентов. Мы поставляем электронные компоненты отечественного и импортного производства напрямую от производителей и с крупнейших складов мира.

Благодаря сотрудничеству с мировыми поставщиками мы осуществляем комплексные и плановые поставки широчайшего спектра электронных компонентов.

Собственная эффективная логистика и склад в обеспечивает надежную поставку продукции в точно указанные сроки по всей России.

Мы осуществляем техническую поддержку нашим клиентам и предпродажную проверку качества продукции. На все поставляемые продукты мы предоставляем гарантию .

Осуществляем поставки продукции под контролем ВП МО РФ на предприятия военно-промышленного комплекса России , а также работаем в рамках 275 ФЗ с открытием отдельных счетов в уполномоченном банке. Система менеджмента качества компании соответствует требованиям ГОСТ ISO 9001.

Минимальные сроки поставки, гибкие цены, неограниченный ассортимент и индивидуальный подход к клиентам являются основой для выстраивания долгосрочного и эффективного сотрудничества с предприятиями радиоэлектронной промышленности, предприятиями ВПК и научно-исследовательскими институтами России.

С нами вы становитесь еще успешнее!

Наши контакты:

Телефон: +7 812 627 14 35

Электронная почта: sales@st-electron.ru

Адрес: 198099, Санкт-Петербург,
Промышленная ул, дом № 19, литера Н,
помещение 100-Н Офис 331