



Electronic Components

High Quality

CAPACITORS

ALUMINUM ELECTROLYTIC CAPACITORS WITH CONDUCTIVE POLYMER SOLID ELECTROLYTE

ALUMINUM ELECTROLYTIC CAPACITORS

ELECTRIC DOUBLE LAYER CAPACITORS "DYNACAP®"

PLASTIC FILM CAPACITORS

ELNA CO., LTD.

CAT.No.2015/2016E

Certifications of Quality Management System (as of Dec. 2014)

| Factory | Applicable Standard | Certification Number | Item | Applicable Organization |
|--|---------------------|--------------------------------|--|-------------------------|
| ELNA TOHOKU CO., LTD. AOMORI Factory (Japan) | ISO 9001 | JP10/062038 | Aluminum electrolytic capacitors Aluminum Electrolytic Capacitors With Conductive Polymer Solid Electrolyte Electric double layer capacitors | SGS |
| ELNA CO., LTD. SHIRAKAWA Tech. (Japan) | ISO/TS 16949 | IATF0178185 SGS JP14/062589 | Aluminum electrolytic capacitors Aluminum Electrolytic Capacitors With Conductive Polymer Solid Electrolyte | SGS |
| TANIN ELNA CO., LTD. (Thailand) | ISO/TS 16949 | IATF0145255 44 111 060686 | Aluminum electrolytic capacitors Electric double layer capacitors | TÜV |
| | ISO 9001 | 04 100 990506 | Aluminum electrolytic capacitors Electric double layer capacitors | TÜV |
| ELNA-SONIC SDN. BHD. (Malaysia) | ISO/TS 16949 | IATF0170448 SGS MY04/0675 | Aluminum electrolytic capacitors | SGS |
| | ISO 9001 | SG02/20012 | Aluminum electrolytic capacitors | SGS |

Certifications of Environmental Management System (as of Dec. 2014)

| Factory | Applicable Standard | Certification Number | Applicable Organization |
|--|---------------------|----------------------|----------------------------------|
| ELNA TOHOKU CO., LTD. AOMORI Factory (Japan) | ISO 14001 | JQA-EM2918 | Japan Quality Assurance (JQA) |
| TANIN ELNA CO., LTD. (Thailand) | ISO 14001 | 04104 990506 | TÜV |
| ELNA-SONIC SDN. BHD. (Malaysia) | ISO 14001 | SG03/60718 | SGS |

Please read the following warning and cautions !!

The Electronic components shown in this catalog are designed and produced mainly for such general purpose electronic equipment as audio and visual equipment, home appliances, office equipment and information processing and communication equipment.

If you wish to use these components in medical equipment, transportation equipment, (automotive, train, ships, etc), aircraft, spacecraft, security systems or other equipment that requires high security application, you are required to confirm application through your own testing and own judgment.

Regardless of a component intended use, if high safety application is required, it is recommended that you shall establish a protective or redundant circuit and shall conduct own evaluation test.

It is highly recommended that you shall follow our "Cautions for using"

Also it is recommended that you shall obtain technical specifications from Elna Co., Ltd to ensure that the component is suitable for your intended use.

It is not our responsibility for any kind of problems without technical specifications.

Specifications and dimensions shown in this catalog are subject to change without prior notice.

Be sure to read “Cautions for Using Electrolytic Capacitors”, before using those products.

| | | | |
|----------|---|-------|-----------------------|
| 1 | Aluminum Electrolytic Capacitors | — 5 | |
| | Polymer hybrid type Electrolytic Capacitors | | POLYMER HYBRID |
| | Aluminum Electrolytic Capacitors With Conductive Polymer Solid Electrolyte | — 21 | |
| | Chip Type Aluminum Electrolytic Capacitors | — 53 | CHIP ALUMINUM |
| | Miniature Aluminum Electrolytic Capacitors | — 89 | MINIATURE ALUMINUM |
| | Large Capacitance Aluminum Electrolytic Capacitors | — 139 | LARGE ALUMINUM |
| | Aluminum Electrolytic Capacitors for Audio | — 163 | FOR AUDIO ALUMINUM |
| 2 | Electric Double Layer Capacitors “DYNACAP” , “POWERCAP” | — 187 | EDLC |
| 3 | Plastic film Capacitors | — 229 | PLASTIC FILM |

■ “GREEN CAP”

“GREEN CAP”, ELNA considers the global environment and it is a product that doesn't use the hazardous substance and “Lead Free” in the plating of terminals and outer Sleeves.

The product in this catalog is 'GREEN CAP'.

The hazardous substance is

Pb : lead, Cr⁶⁺ : hexavalent chromium, Hg : mercury and Cd : cadmium,
PBB : the polybrominated biphenyl, PBDE : the polybromo-diphenyl ether,

■ Regarding to various environmental Regulations

- It suits “EU RoHS Directives”.
- According to the content of RIP3.8TGD(Technical Guidance Document which is published on 26 May 2008), our electronic components are “articles without any intended release”.
Therefore they are not applicable for “Registration” for EU REACH Regulation Article 7 (1).
ELNA develops the products without substance of very high concern(SVHC). DEHP(CASNo.117-81-7) was contained as some covering material.
- If you need “Halogen-Free” products, please consult with us.

Terminal area plating material and sleeve material

● Aluminum electrolytic capacitors

| Category | | Terminal area plating | Plating thickness | Sleeve |
|--------------------|------------------------------------|-----------------------|-------------------|--------------------|
| SMD (Chip type) | φ 3 to 6.3 | Sn-Bi | 12μm | Sleeve less |
| | φ 8,10 | Sn-Bi | 12μm | PET or sleeve less |
| | φ 12.5 | Sn 100% | 12μm | PET or sleeve less |
| | φ 16 to 18 | Sn 100% | 12μm | Sleeve less |
| | Supplementary terminal of RT* type | Sn 100% | 12μm | PET or sleeve less |
| | Supplementary terminal of RY* type | Sn 100% | 12μm | Sleeve less |
| Lead terminal | | Sn 100% | 12μm | PET or sleeve less |
| Snap-in | | Sn 100% | 12μm | PET |
| Screw terminal | | — | | PVC * |

* Pb less PVC

● Electric double layer capacitors

| Category | | Terminal area plating | Plating thickness | Sleeve | |
|-------------------|------------------|-----------------------|-------------------|--------|-------------|
| Coin cell | SMD | Single cell | Sn 100% | 5μm | Sleeve less |
| | | Piled cell | Sn 100% | 5μm | PET |
| | Lead type | | Sn 100% | 5μm | PET |
| Large capacitance | Lead terminal | | Sn 100% | 12μm | PET |
| | Snap-in terminal | | Sn 100% | 12μm | PET |
| | Screw terminal | | — | | PET |

Note : Sn : Tin Bi : Bismuth

Please inquire when hoping excluding the above-mentioned terminal plating and sleeve.

■ About the Sn whisker

1. Sn whisker-generating mechanism on the lead wire

On the surface of the lead wire, Sn and aluminum will get mixed instead of getting dissolved.

The surface condition is complex, aluminum will expand due to the heat and humid causing the oxidation and hydration. This reaction will cause the inner stress and influence the development of the whisker.

2. Generation control of the Sn whisker

In the past, Sn whisker was reduced by adding a lead(Pb). Aluminum electrolytic capacitor was also using the Sn-plate with Pb on the lead wire.

But due to environmental regulation such as the “ELV” and “RoHS”, Pb was strictly prohibited since 2000.

Lead wire not containing the Pb was used, which caused the Sn whisker problem to happen again.

Since Sn whisker is influenced by the mixture of aluminum, method of reducing the aluminum on the welding surface was to clean the lead terminal using the alkali.

However since the welding area of the large case size is larger compared to the small ones, whisker will generate even if it is cleaned by alkali. This whisker will scatter outside of the capacitor and potentially cause the short-circuit. Countermeasure of keeping the whisker inside the capacitor is being discussed.

3. Prevention of scattering of Sn whisker

In the past Sn-plate with Pb was used and recently plate with Bi is being introduced to prevent the whisker from generating. However the whisker will still generate under the temperature and moisture condition.

Therefore, the current method of preventing the whisker will not completely prevent the whisker from generating.

In our company, we are developing and supplying products with design of preventing the whisker from scattering outside the capacitor.

This design corresponds to series such as the RJD and RJE for 105°C use, RKD and RPK for 125°C use.

If it is required for the other series, please feel free to make an inquiry.

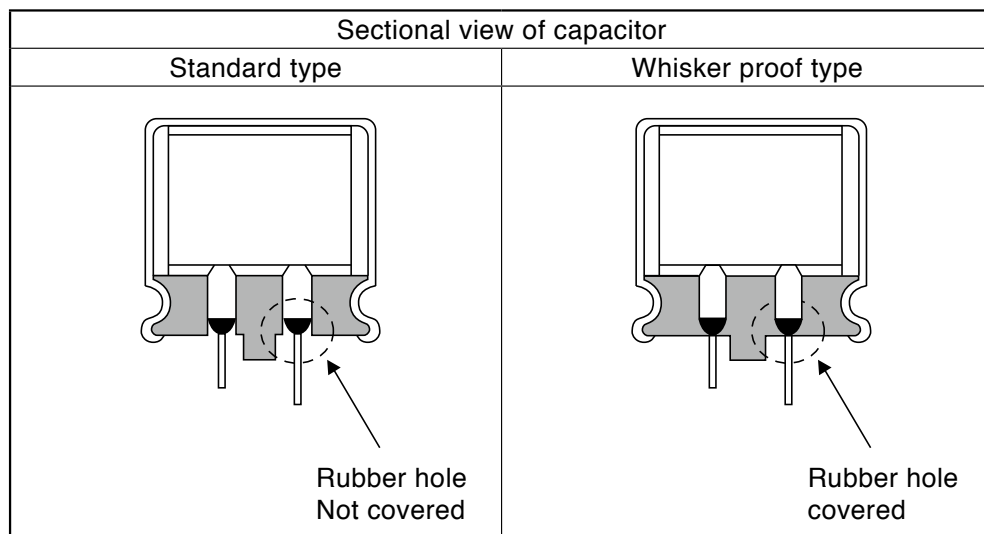

Ordering Information

Please designate the number of capacitors you order in integral multiples of the minimum packing number of units.

Aluminum Electrolytic Capacitors

| Classification | Case Size φD×L (mm) | Quantity (PCS.) | | | | | | | | |
|---|------------------------------|-----------------------|---------------|------------------------|---------------|-------------------|--------------------|---------------|--------------------|-------|
| | | Long lead | | Forming lead | | Taping (flat box) | | Taping (reel) | | |
| | | Vinyl bag | Packaging box | Vinyl bag or small box | Packaging box | Box | Packaging quantity | One reel | Packaging quantity | |
| Aluminum Electrolytic Capacitors With Conductive Polymer Solid Electrolyte Conductive Polymer Hybrid Aluminum Electrolytic Capacitors | Chip Type | φ5 to φ6.3×4.0 to 7.7 | — | — | — | — | — | — | 1,000 | 5,000 |
| | | φ8×6.7 to 7.7 | — | — | — | — | — | — | 1,000 | 4,000 |
| | | φ8×8.7 to 10.5,φ10 | — | — | — | — | — | — | 500 | 2,000 |
| | O4 Type | φ6.3×8 | 200 | 2,000 | 200 | 2,000 | 2,000 | 20,000 | — | — |
| | | φ8×8 | 200 | 2,000 | 200 | 2,000 | 1,000 | 10,000 | — | — |
| φ10×12.5 | | 200 | 1,000 | 200 | 1,000 | 500 | 5,000 | — | — | |
| Chip Type | φ3,φ4 | — | — | — | — | — | — | 2,000 | 10,000 | |
| | φ5 to φ6.3×4.5 to 7.7,φ8×6.5 | — | — | — | — | — | — | 1,000 | 5,000 | |
| | φ8 to φ10×10 to 10.5 | — | — | — | — | — | — | 500 | 2,000 | |
| | φ12.5×13.5 | — | — | — | — | — | — | 200 | 1,000 | |
| | φ16×16.5,φ18×16.5 | — | — | — | — | — | — | 125 | 250 | |
| | φ16×21.5,φ18×21.5 | — | — | — | — | — | — | 75 | 150 | |
| O4 Type | 9.5×19 to 24 | — | — | — | — | — | — | 400 | (2,000) | |
| | φ3 to φ5×5,φ4×7 | 200 | 2,000 | 200 | 5,000 | 2,000 | 20,000 | — | — | |
| | φ5×7 | 200 | 2,000 | 200 | 4,000 | 2,000 | 20,000 | — | — | |
| | φ6.3×5,φ6.3×7 | 200 | 2,000 | 200 | 2,000 | 2,000 | 20,000 | — | — | |
| | φ8×5 to 7 | 200 | 2,000 | 200 | 2,000 | 1,000 | 10,000 | — | — | |
| | φ5 to φ6.3×11,11.5 | 200 | 2,000 | 200 | 2,000 | 2,000 | 20,000 | — | — | |
| | φ8×11.5,12 | 200 | 2,000 | 200 | 2,000 | 1,000 | 10,000 | — | — | |
| | φ8×15 | 200 | 1,000 | 200 | 1,000 | 1,000 | 8,000 | — | — | |
| | φ8×20 | 200 | 1,000 | 200 | 1,000 | 1,000 | 8,000 | — | — | |
| | φ10×12.5 | 200 | 1,000 | 200 | 4,000 | 500 | 5,000 | — | — | |
| | φ10×16 | 200 | 1,000 | 200 | 1,000 | 500 | 4,000 | — | — | |
| | φ10×20 | 200 | 1,000 | 100 | 500 | 500 | 4,000 | — | — | |
| | φ10×25 to 30 | 200 | 1,000 | 100 | 500 | 500 | 3,000 | — | — | |
| | φ12.5×15 to 20 | 100 | 1,000 | 100 | 500 | 500 | 4,000 | — | — | |
| | φ12.5×25 | 100 | 500 | 100 | 1,000 | 500 | 2,000 | — | — | |
| | φ12.5×30 | 100 | 500 | 200 | 2,000 | 500 | 3,000 | — | — | |
| | φ12.5×35 | 100 | 500 | 200 | 2,000 | 500 | 2,000 | — | — | |
| | φ12.5×40 | 100 | 500 | 200 | 2,000 | — | — | — | — | |
| | φ16×16 to 25 | 100 | 500 | 100 | 1,000 | 250 | 1,000 | — | — | |
| | φ16×31.5 to 35.5 | 50 | 200 | 100 | 1,000 | 250 | 2,000 | — | — | |
| | φ16×40 | 50 | 100 | 100 | 800 | — | — | — | — | |
| | φ18×16 | 50 | 100 | 100 | 1,000 | 250 | 1,000 | — | — | |
| | φ18×20 to 25 | 50 | 100 | 100 | 1,000 | 250 | 1,500 | — | — | |
| φ18×31.5 to 35.5 | 50 | 100 | 100 | 1,000 | — | — | — | — | | |
| φ18×40 | 50 | 250 | 100 | 800 | — | — | — | — | | |
| φ20×25 to 35.5 | 50 | 100 | 100 | 1,000 | — | — | — | — | | |
| φ20 to 22×40 | 50 | 250 | 100 | 800 | — | — | — | — | | |
| 69□Type | φ22 to φ25 | — | 100 | — | — | — | — | — | — | |
| 331Type or Others | φ30 to φ35 | — | 50 | — | — | — | — | — | — | |
| | φ36 to φ101 | — | * | — | — | — | — | — | — | |

* Please inquire.

Electric Double Layer Capacitors

| Series | Case size φD×L(mm) | Quantity (PCS.) | | | | | | | |
|---------------------------------|-----------------------|-----------------|---------------|------------------------|---------------|-------------------|--------------------|-----------------|--------------------|
| | | Long lead | | Standard lead | | Taping (flat box) | | Taping (reel) | |
| | | Vinyl bag | Packaging box | Vinyl bag | Packaging box | Box | Packaging quantity | One reel | Packaging quantity |
| DX,DXJ,DXN,DXS(H or V Terminal) | φ11.5 | — | — | 200 | 2,000 | — | — | — | — |
| DX,DXJ,DXN(V Terminal) | φ19 | — | — | 100 | 500 | — | — | — | — |
| DH,DHL,DHC,DBJ | φ13.5 | — | — | 200 | 1,000 | — | — | — | — |
| DK,DB,DBN,DBS | φ21.5 | — | — | 100 | 500 | — | — | — | — |
| DC,DCK | φ6.8 | — | — | 200 | 6,000 | — | — | — | — |
| DS,DSK | φ4.8 | — | — | — | — | — | — | 2,000 | 10,000 |
| | φ6.8 | — | — | — | — | — | — | 1,500 to 2,000* | 6,000 to 10,000* |
| DVN | φ12.5×8.5 | — | — | — | — | — | — | 300 | 1,500 |
| DVL | φ12.5×10.5 | — | — | — | — | — | — | 250 | 1,250 |
| Series | Case size φD×L(mm) | Quantity (PCS.) | | | | | | | |
| | | Long lead | | Forming lead | | Taping (flat box) | | Taping (reel) | |
| | | Vinyl bag | Packaging box | Vinyl bag or small box | Packaging box | Box | Packaging quantity | One reel | Packaging quantity |
| DY DZ DZN DZH | φ6.3,φ8×12 | 200 | 2,000 | 200 | 2,000 | 2,000 | 10,000 | — | — |
| | φ8×15 to 22 | 200 | 1,000 | 200 | 1,000 | 1,000 | 8,000 | — | — |
| | φ10×20 | 200 | 1,000 | 100 | 500 | 500 | 4,000 | — | — |
| | φ10×30 to 35 | 200 | 1,000 | 100 | 500 | 500 | 3,000 | — | — |
| | φ12.5×23 | 100 | 500 | 100 | 1,000 | 500 | 2,000 | — | — |
| | φ12.5×31.5 | 100 | 500 | 200 | 2,000 | 500 | 2,000 | — | — |
| | φ16×20 to 25 | 100 | 500 | 100 | 1,000 | 250 | 1,000 | — | — |
| | φ16×31.5 to 35.5 | 50 | 200 | 100 | 1,000 | 250 | 2,000 | — | — |
| | φ18×35 | 50 | 100 | 100 | 1,000 | — | — | — | — |
| | φ18×40 | 50 | 250 | 100 | 800 | — | — | — | — |
| DP | φ25 | — | 50 or 100* | — | — | — | — | — | — |
| | φ35 | — | 50 or 100* | — | — | — | — | — | — |
| | φ51 | — | 32 | — | — | — | — | — | — |
| DZP | 8.5×17×16 | — | * | — | — | — | — | — | — |
| | 8.5×17×24 | | | | | | | | |
| | 10.5×21×34 | | | | | | | | |
| | 10.5×21×39 | | | | | | | | |

* Please inquire.

ELNA[®]

Aluminum Electrolytic Capacitors

List of Contents

| | |
|--|-----|
| 1. Type List for Aluminum Electrolytic Capacitors | 6 |
| 2. Systematized Classification of Aluminum Electrolytic Capacitors | 8 |
| 3. Product Symbol System for Aluminum Electrolytic Capacitors | 10 |
| 4. Recommended Land Pattern and Size, for Chip Type | 11 |
| 5. Recommended Soldering Conditions | 12 |
| 6. Recommended Taping for Chip Type | 14 |
| 7. Lead Forming and Taping for Lead Type | 15 |
| 8. Cautions for Using Aluminum Electrolytic Capacitors With Conductive Polymer Solid Electrolyte | 22 |
| 9. Specifications for Polymer Hybrid Type Aluminum Electrolytic Capacitors by Series | 26 |
| 10. Specifications for Aluminum Electrolytic Capacitors With Conductive Polymer Solid Electrolyte by Series | 30 |
| 11. Cautions for Using Aluminum Electrolytic Capacitors | 48 |
| 12. Specifications for Chip Type Aluminum Electrolytic Capacitors by Series | 53 |
| 13. Specifications for Miniature Aluminum Electrolytic Capacitors by Series | 89 |
| 14. Specifications for Large Aluminum Electrolytic Capacitors by Series | 139 |
| 15. Specifications for Aluminum Electrolytic Capacitors for Audio by series | 163 |
| 16. Technical Notes of Aluminum Electrolytic Capacitors | 178 |



■ Type List for Miniature and Chip Type Aluminum Electrolytic Capacitors

★ : New series
☆ : Upgrade

| Category | Series | Page | Applications | Feature | | | | | | | | Category Temp. Range °C | | Rated Voltage Range V.DC | | Rated Capacitance Range µF | | Color of sleeve | JIS Configuration | Note |
|-----------------------|--------|--|---|----------------------|---|---|---|---|-----------|-----------------------|-----------------------------|-------------------------|-------|--------------------------|-------------|----------------------------|--------------|-----------------|-------------------|------|
| | | | | Thin and small Size | | | | | For Audio | Anti-cleaning solvent | Reflow Soldering Resistance | | | | | | | | | |
| | | | | Reliability at 105°C | | | | | | | | | | | | | | | | |
| Hybrid Polymer | HV | 26 | Low ESR Hybrid Polymer Chip | | | | • | • | | | | | + 105 | - 55 | 80 | 25 | 22 to 330 | Silver | | ★ |
| | HT | 26 | Low ESR Hybrid Polymer Chip, Vibration resistance | | | | • | • | | | | | + 105 | - 55 | 80 | 25 | 22 to 330 | Silver | | ★ |
| | HVK | 28 | Low ESR, High Temp. Hybrid Polymer Chip | | | | | | • | • | | | + 125 | - 55 | 63 | 25 | 22 to 330 | Silver | | ★ |
| | HTK | 28 | Low ESR, High Temp. Hybrid Polymer Chip, Vibration resistance | | | | | | • | • | | | + 125 | - 55 | 63 | 25 | 33 to 330 | Silver | | ★ |
| Polymer | PVG | 30 | Ultra Low ESR Conductive Polymer Chip | | | • | | | • | • | • | + 105 | - 55 | 6.3 | 2.5 | 120 to 1200 | Silver | 32 | | |
| | PVX | 32 | Ultra Low ESR Conductive Polymer Chip | | | • | | | • | • | • | + 105 | - 55 | 10 | 2.5 | 100 to 1200 | Silver | 32 | | |
| | PV3 | 34 | Super Low ESR Conductive Polymer Chip, 4.0mmL | • | • | | | | • | • | • | + 105 | - 55 | 6.3 | 2.5 | 150 to 220 | Silver | 32 | ★ | |
| | PV2 | 36 | Super Low ESR Conductive Polymer Chip, 4.5mmL | • | • | | | | • | • | • | + 105 | - 55 | 25 | 2.5 | 15 to 390 | Silver | 32 | | |
| | PVM | 38 | Super Low ESR Conductive Polymer Chip | | | • | | | • | • | • | + 105 | - 55 | 35 | 2.5 | 10 to 1200 | Silver | 32 | | |
| | PVH | — | Low ESR Conductive Polymer Chip | | | • | | | • | • | • | + 105 | - 55 | 35 | 2.5 | 10 to 1000 | Silver | 32 | | |
| | PVK | 40 | Super Low ESR, High Temp. Conductive Polymer Chip | | | • | | | • | • | • | + 125 | - 55 | 25 | 2.5 | 33 to 1000 | Silver | 32 | | |
| | PVS | 42 | Super Low ESR, High Voltage Conductive Polymer Chip | | | • | | | • | • | • | + 105 | - 55 | 63 | 35 | 18 to 100 | Silver | 32 | | |
| | PRM | 44 | Super Low ESR Conductive Polymer | | | • | | | • | • | • | + 105 | - 55 | 10 | 2.5 | 220 to 1500 | Silver | 04 | | |
| Surface Mounting Type | RV2 | — | 5.5mm L | • | | | | | • | • | • | + 85 | - 40 | 50 | 4 | 0.22 to 220 | Silver | 32 | | |
| | RV | — | Higher Capacitance Range | • | | | | | • | • | • | + 85 | - 40 | 100 | 6.3 | 10 to 2200 | Silver/Brown | 32 | | |
| | RV3 | — | High CV | • | | | | | • | • | • | + 85 | - 40 | 50 | 6.3 | 4.7 to 330 | Silver | 32 | | |
| | RV4 | 56 | 4.5mm L | • | | | | | • | • | • | + 85 | - 40 | 50 | 6.3 | 0.22 to 100 | Silver | 32 | | |
| | RV5 | 54 | High CV | • | | | | | • | • | • | + 85 | - 40 | 100 | 6.3 | 2.2 to 2200 | Silver/Brown | 32 | ☆ | |
| | RVB | 57 | Non Polarized | • | | | | | • | • | • | + 85 | - 40 | 50 | 6.3 | 0.22 to 47 | Silver | 32 | | |
| | RVE | 82 | 105°C , 4.5mmL | • | • | | | | • | • | • | + 105 | - 40 | 50 | 6.3 | 0.22 to 100 | Silver | 32 | | |
| | RVS | 58 | 105°C , 5.5mm L | • | • | | | | • | • | • | + 105 | - 55 | 50 | 6.3 | 0.22 to 1500 | Silver | 32 | | |
| | RVL | 60 | Long Life, 105°C , 6.0mm L | • | • | | | | • | • | • | + 105 | - 55 | 50 | 6.3 | 0.22 to 100 | Silver | 32 | | |
| | RVR | 62 | 105°C , Long Life, High CV | • | • | | | | • | • | • | + 105 | - 40 | 50 | 4 | 0.22 to 1500 | Silver | 32 | | |
| | RVJ | 61 | 105°C , Higher Capacitance | | | • | | | • | • | • | + 105 | - 55 | 100 | 6.3 | 10 to 1000 | Silver/Brown | 32 | | |
| | RVC | 64 | 105°C, 3000h/5000h | | | • | • | | • | • | • | + 105 | - 40 | 50 | 6.3 | 0.33 to 1000 | Silver | 32 | | |
| | RVD | 66 | 105°C , Low Impedance, Long life | | | • | • | | • | • | • | + 105 | - 55 | 100 | 6.3 | 4.7 to 2200 | Silver | 32 | ☆ | |
| | RZD | 68 | 105°C , Low Impedance,High CV | | | • | | | • | • | • | + 105 | - 55 | 35 | 6.3 | 100 to 2200 | Silver | 32 | ★ | |
| | RVV | 70 | 105°C , Low Impedance, Long life | | | • | | | • | • | • | + 105 | - 55 | 35 | 6.3 | 4.7 to 1500 | Silver | 32 | ☆ | |
| | RVZ | 72 | 105°C , Low Impedance | | | • | | | • | • | • | + 105 | - 55 | 35 | 6.3 | 4.7 to 2700 | Silver/Brown | 32 | | |
| | RZF | 74 | 125°C , Low ESR, Long Life, High CV | • | | | | • | • | • | • | + 125 | - 40 | 35 | 10 | 47 to 680 | Silver | 32 | ★ | |
| | RZE | 76 | 125°C , Low ESR, High CV | • | | | • | | • | • | • | + 125 | - 40 | 35 | 35 | 47 to 100 | Silver | 32 | ★ | |
| | RVT | 78 | 125°C , Low ESR | • | | | • | | • | • | • | + 125 | - 40 | 100 | 10 | 4.7 to 1000 | Silver | 32 | ☆ | |
| | RVK | 80 | 125°C , Higher Reliability | | | | • | | • | • | • | + 125 | - 40 | 63 | 10 | 10 to 1000 | Brown | 32 | | |
| | RVX | 81 | 135°C , Higher Reliability | | | | • | • | • | • | • | + 135 | - 40 | 35 | 25 | 22 to 330 | Silver | 32 | | |
| | RVI | 83 | 105°C , Non Polarized, 2000h | • | • | | | | • | • | • | + 105 | - 40 | 50 | 6.3 | 0.33 to 47 | Silver | 32 | | |
| | RTJ | — | 105°C , Higher Capacitance, Vibration resistance | | | • | | | • | • | • | + 105 | - 55 | 100 | 6.3 | 10 to 470 | Brown | 32 | | |
| | RTK | 84 | 125°C , Vibration resistance | | | | • | | • | • | • | + 125 | - 40 | 63 | 10 | 10 to 330 | Brown | 32 | | |
| RTZ | 85 | 105°C , Low Z, High CV, 30G Vibration resistance | | | • | • | | • | • | • | + 105 | - 55 | 35 | 6.3 | 150 to 8200 | Silver | 32 | ☆ | | |
| RTD | 86 | 105°C , Low Z, High CV, 30G Vibration resistance | | | | • | | • | • | • | + 105 | - 55 | 100 | 6.3 | 100 to 8200 | Silver | 32 | ☆ | | |
| RTT | 87 | 125°C , Low ESR, High CV, 30G Vibration resistance | | | | • | • | • | • | • | + 125 | - 40 | 100 | 10 | 47 to 4700 | Silver | 32 | ☆ | | |
| RYK | 88 | 125°C , Horizontal type | | | | • | | • | • | • | + 125 | - 40 | 63 | 6.3 | 56 to 820 | Black | 88 | | | |
| Ultra-miniature Type | RC3 | 90 | 5mm L, Standard | • | | | | | • | • | • | + 85 | - 40 | 50 | 4 | 0.22 to 470 | Black/Blue | 04 | | |
| | R3S | 91 | 5mm L, 105°C | • | • | | | | • | • | • | + 105 | - 55 | 50 | 6.3 | 0.33 to 100 | Black | 04 | | |
| | RB3 | 92 | 5mm L, Bipolar | • | | | | | • | • | • | + 85 | - 40 | 50 | 6.3 | 0.33 to 47 | Blue | 04 | | |
| | RC2 | 93 | 7mm L, Standard | • | | | | | • | • | • | + 85 | - 40 | 100 | 4 | 0.33 to 330 | Blue | 04 | | |
| | R2S | 94 | 7mm L, 105°C | • | • | | | | • | • | • | + 85 | - 55 | 50 | 6.3 | 0.33 to 100 | Black | 04 | | |
| | RB2 | 95 | 7mm L, Bipolar | • | | | | | • | • | • | + 85 | - 40 | 50 | 6.3 | 0.33 to 47 | Blue | 04 | | |

■ Type List for Miniature and Large type Aluminum Electrolytic Capacitors

○ : Apply to those capacitors with rated voltage of 250V or less.

★ : New series

☆ : Upgrade

| Category | Series | Page | Applications | Thin and small Size | Feature | | | | | | Category Temp. Range °C | Rated Voltage Range V.DC | | Rated Capacitance Range μF | Color of sleeve | JIS Configuration | Note | | | |
|-----------------------|--------|------------------------------------|---|---------------------|----------------------|---------|---------|---------|------------------|---------------|-------------------------|--------------------------|-----------------------|----------------------------|-----------------|-------------------|----------------|--------------------------|------|------|
| | | | | | Reliability at 105°C | | | | | Low Impedance | | For Audio | Anti-cleaning solvent | | | | | Reflow Solder Resistance | Max. | Min. |
| | | | | | 1000hrs | 2000hrs | 3000hrs | 5000hrs | 10000hrs or more | | | | | | | | | | | |
| Standard Type | RE3 | 96 | Miniaturized Standard | • | | | | | | | | | +85 | -40 | 450 | 6.3 | 0.47 to 22000 | Blue | 04 | |
| | R2B | 98 | Bipolarity Standard | | | | | | | | | | +85 | -40 | 100 | 6.3 | 1 to 4700 | Blue | 04 | |
| | RJP | 99 | 105°C, Bipolar | | • | | | | | | | | +105 | -40 | 50 | 6.3 | 1 to 6800 | Black | 04 | |
| | RJ5 | 100 | 105°C, Miniaturized, High CV | • | • | | | | | | | | +105 | -55 | 100 | 6.3 | 1 to 22000 | Black | 04 | |
| | RJ4 | 102 | 105°C, Miniaturized | • | • | | | | | | | | +105 | -40 | 450 | 160 | 0.47 to 330 | Black | 04 | |
| | RJ3 | 104 | 105°C, Low Impedance | | • | | | | | | | | +105 | -55 | 100 | 6.3 | 1 to 15000 | Black | 04 | |
| Special Type | RLB | 137 | Low-leakage Current | | | | | | | | | | +85 | -40 | 50 | 6.3 | 1 to 2200 | Blue | 04 | |
| High Reliability Type | RJB | 106 | 105°C, Low Impedance, Miniaturized | | | | • | • | • | | | | +105 | -55 | 100 | 6.3 | 3.3 to 10000 | Black | 04 | |
| | RJH | 108 | 105°C, Extra Low Impedance | | | | • | • | • | | | | +105 | -55 | 100 | 6.3 | 1 to 15000 | Black | 04 | |
| | RJF | 111 | 105°C, Extra Low Impedance, Miniaturized | | | | • | • | • | | | | +105 | -40 | 100 | 6.3 | 5.6 to 6800 | Black | 04 | |
| | RJL | 114 | 105°C, Long life, Low Impedance | • | | | • | • | • | | | | +105 | -40 | 100 | 6.3 | 6.8 to 6800 | Black | 04 | |
| | RJM | 116 | 105°C, Long life, Low Impedance | • | | | • | • | • | | | | +105 | -40 | 50 | 6.3 | 27 to 8200 | Black | 04 | ★ |
| | RJD | 118 | 105°C, Low Impedance, High Ripple, Miniaturized | • | | | • | • | • | | | | +105 | -55 | 100 | 6.3 | 10 to 18000 | Black | 04 | ☆ |
| | RJE | 121 | 105°C, Low Impedance, High Ripple, For Airbag | • | | | • | • | • | | | | +105 | -55 | 35 | 25 | 830 to 11000 | Black | 04 | |
| | RHS | 122 | 105°C, Long Life, High Ripple, For Ballast | • | | | • | | | | | | +105 | -40 | 250 | 160 | 4.7 to 560 | Black | 04 | ☆ |
| | RHC | 124 | 105°C, Long Life, High Ripple, For Ballast | • | | | • | | | | | | +105 | -25 | 450 | 160 | 1 to 680 | Black | 04 | ☆ |
| | RHD | 126 | 105°C, Long Life, High Ripple, For Ballast | • | | | • | | | | | | +105 | -25 | 450 | 160 | 3.3 to 680 | Black | 04 | ☆ |
| | RKE | 128 | 125°C, Low Impedance, 40G Vibration resistance | • | | | • | • | • | | | | +125 | -40 | 100 | 10 | 100 to 8200 | Silver | 04 | ★ |
| | RKD | 130 | 125°C, Low Impedance, Miniaturized | • | | | • | • | • | | | | +125 | -40 | 100 | 10 | 100 to 8200 | Black | 04 | ☆ |
| | RPK | 132 | 125°C, Low Impedance, 30G Vibration resistance | • | | | • | • | • | | | | +125 | -40 | 100 | 10 | 220 to 8200 | Black | 04 | ☆ |
| | RQA | 136 | 150°C, Low Impedance, Miniaturized | • | | | • | • | • | | | | +150 | -40 | 63 | 10 | 220 to 4700 | Silver | 04 | ☆ |
| RKB | 134 | 135°C, Low Impedance, Miniaturized | • | | | • | • | • | | | | +135 | -40 | 100 | 10 | 220 to 6800 | Silver | 04 | ☆ | |
| Snap-in Type | LA5 | 140 | Miniaturized | • | | | | | | | | | +85 | -40 | 400 | 10 | 56 to 82000 | Black | 692 | |
| | LAT | 142 | 105°C, Miniaturized | • | • | | | | | | | | +105 | -25 | 450 | 160 | 22 to 2700 | Black | 692 | ☆ |
| | LAH | 144 | 105°C, Standard | • | • | | | | | | | | +105 | -40 | 100 | 16 | 560 to 47000 | Black | 692 | ☆ |
| | LAZ | 146 | High-Reliability, High Ripple, Long Life | • | • | | | | | | | | +105 | -25 | 450 | 160 | 56 to 2200 | Black | 692 | |
| | LAX | 148 | 105°C, Ultra Long Life | | | | • | | | | | | +105 | -25 | 450 | 160 | 56 to 1800 | Black | 692 | ☆ |
| | LJ6 | 150 | 105°C, Higher Capacitance, Ultra Long Life | | | | • | | | | | | +105 | -25 | 500 | 200 | 390 to 3900 | Black | - | |
| | LJ2 | 150 | 105°C, Higher Capacitance, Ultra Long Life | | | | • | | | | | | +105 | -25 | 500 | 200 | 560 to 3900 | Black | - | |
| Special Type | LPM | 152 | High ripple current | | | | | | | | | | +85 | -25 | 400 | 250 | 45 to 220 | Black | 692 | |
| | LM | 152 | High ripple current, Higher Capacitance | | | | | | | | | | +85 | -25 | 400 | 250 | 90 to 440 | Black | - | |
| Screw terminal Type | LYX | 154 | 105°C, Ultra Long Life | | | | • | | | | | | +105 | -25 | 450 | 350 | 1000 to 15000 | Black | 331 | |
| | LYL | 156 | Ultra Long Life | | | | | | | | | | +85 | -40 | 450 | 350 | 1000 to 15000 | Black | 331 | |
| | LY6 | 158 | High Ripple, Miniaturized | • | | | | | | | | | +85 | -25 | 550 | 400 | 1000 to 22000 | Black | 331 | |
| | LY5 | 160 | Standard | | | | | | | | | | +85 | -40 | 250 | 10 | 1500 to 820000 | Black | 331 | |
| For Audio | RVO | 164 | Chip Type (PURECAP) | • | | | | | | | | | +85 | -40 | 50 | 6.3 | 0.33 to 1000 | Silver Brown | 32 | |
| | RVF | 165 | Chip Type (SILMIC) | • | | | | | | | | | +85 | -40 | 50 | 10 | 0.33 to 100 | Silver | 32 | |
| | RVM | 166 | Chip Type 105°C, 2000h | • | • | | | | | | | | +105 | -55 | 50 | 6.3 | 1 to 470 | Silver | 32 | |
| | RVW | 167 | Chip Type 105°C (PURECAP) | • | • | | | | | | | | +105 | -55 | 50 | 6.3 | 0.33 to 470 | Silver Brown | 32 | |
| | RVG | 168 | Chip Type | • | | | | | | | | | +85 | -40 | 35 | 6.3 | 3.3 to 470 | Silver | 32 | |
| | RFS | 169 | High Grade (SILMIC II) | | | | | | | | | | +85 | -55 | 100 | 6.3 | 2.2 to 3300 | Brown | 04 | |
| | ROS | 170 | High Grade (SILMIC) | | | | | | | | | | +85 | -40 | 100 | 16 | 2.2 to 2200 | Brown | 04 | |
| | ROB | 171 | Miniaturized Standard (TONEREX) | | | | | | | | | | +85 | -40 | 100 | 6.3 | 1 to 10000 | Black | 04 | |
| | R2A | — | 7mmL | • | | | | | | | | | +85 | -40 | 50 | 6.3 | 0.33 to 330 | Black | 04 | |
| | R3A | — | 5mmL | • | | | | | | | | | +85 | -40 | 50 | 4 | 0.22 to 220 | Raddish purple | 04 | |
| | RFO | 172 | Standard (PURECAP) | • | | | | | | | | | +85 | -40 | 100 | 6.3 | 1 to 15000 | Black | 04 | |
| | RA3 | 173 | Miniaturized Standard | • | | | | | | | | | +85 | -40 | 100 | 6.3 | 1 to 22000 | Brown | 04 | |
| | RW5 | 174 | 105°C, Miniaturized | • | • | | | | | | | | +105 | -55 | 25 | 16 | 100 to 15000 | Black | 04 | |
| | RBD | 175 | Miniaturized Bipolar | • | | | | | | | | | +85 | -40 | 100 | 6.3 | 1 to 4700 | Black | 04 | |
| LAO | 176 | For Audio, Higher Capacitance | | | | | | | | | | +85 | -40 | 100 | 16 | 680 to 10000 | Black | 692 | | |

* Be sure to "Cautions for Using Aluminum Electrolytic Capacitors", before using these products.

Some series of the following series were omitted from this catalog.
 RV2, RV, RV3, RTJ, RJJ, RK, LH7, LAV, LUH, PVH, PVO, ROA, R2A, R3A

NOTE : Design, Specifications are subject to change without notice.
 It is recommended that you shall obtain technical specifications from ELNA to ensure that the component is suitable for your use.

Systematized Classification of Miniature and Chip Type Aluminum Electrolytic Capacitors

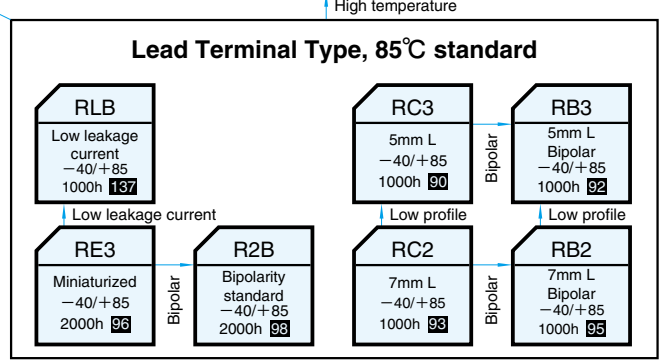
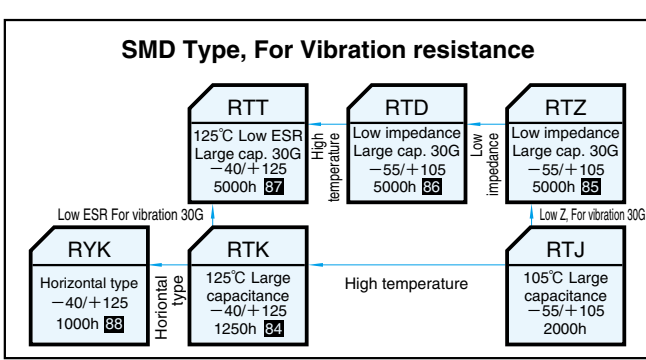
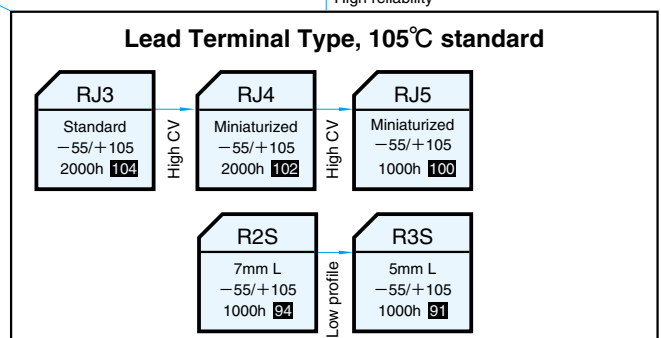
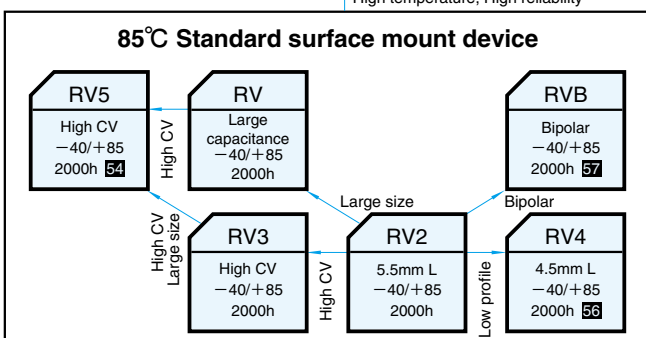
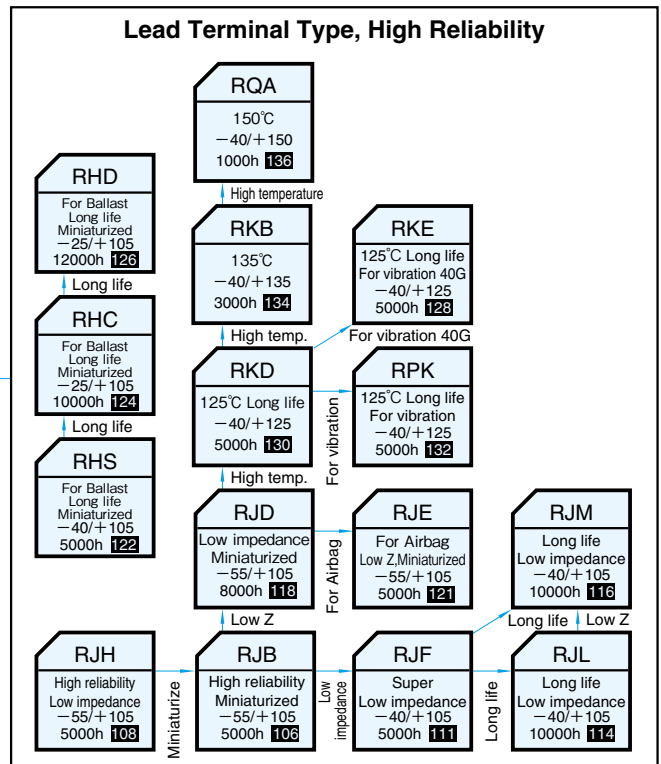
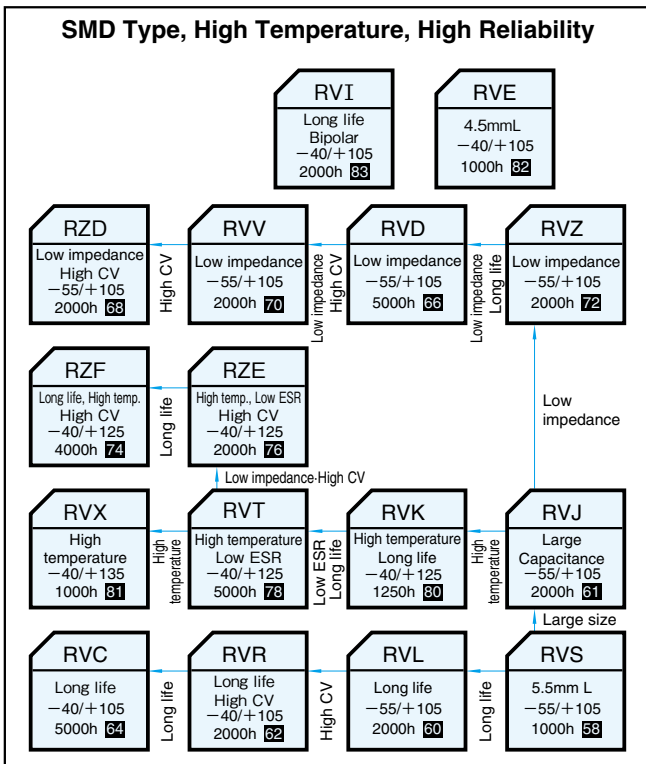
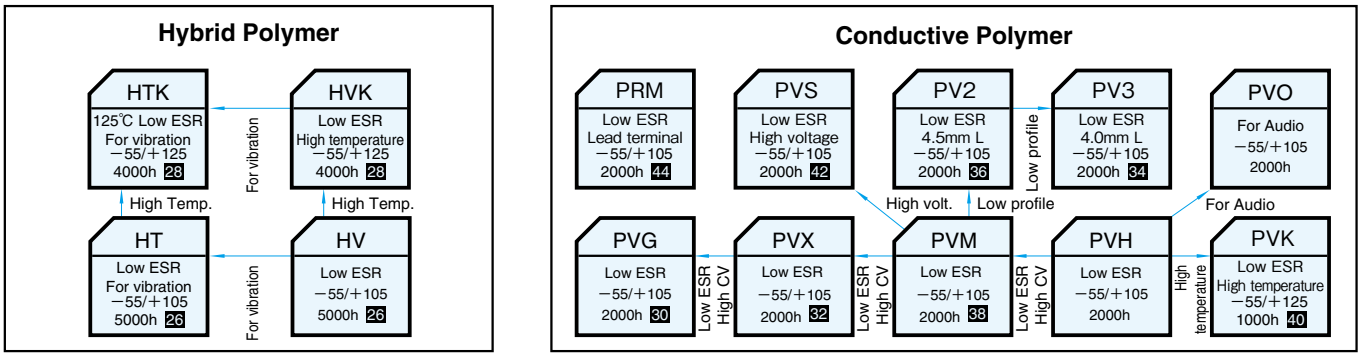

NOTE : Design, Specifications are subject to change without notice. It is recommended that you shall obtain technical specifications from ELNA to ensure that the component is suitable for your use.

■ Systematized Classification of Large Aluminum Electrolytic Capacitors

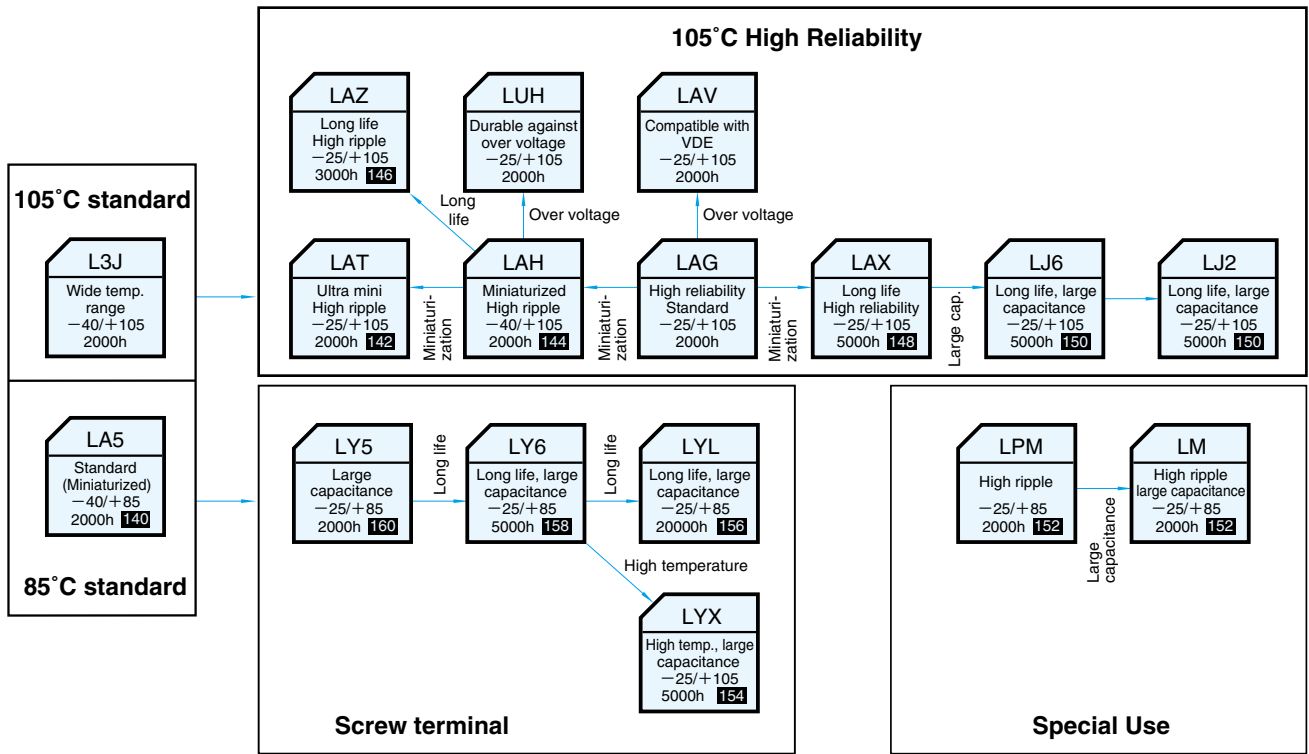

■ Systematized Classification of Aluminum Electrolytic Capacitors For Audio

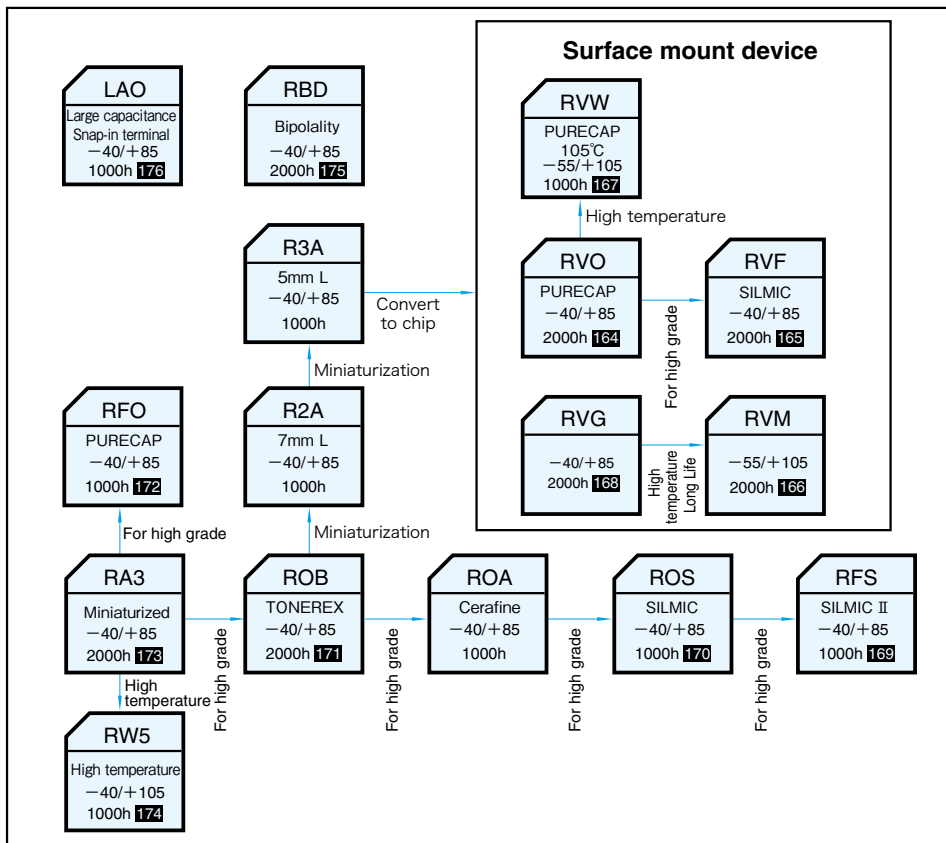

NOTE : Design, Specifications are subject to change without notice. It is recommended that you shall obtain technical specifications from ELNA to ensure that the component is suitable for your use.

■ Product Symbol System for Aluminum Electrolytic Capacitors

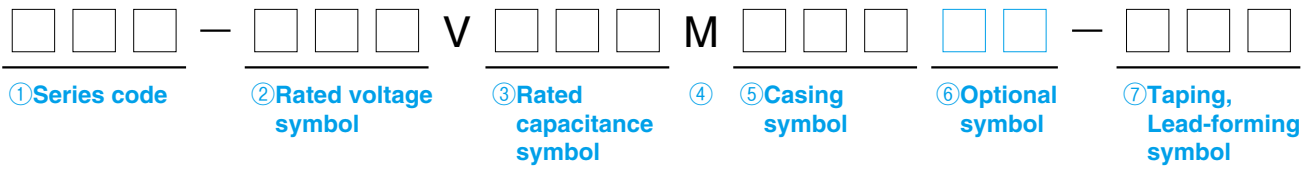

① Series code

Please refer to the page of each series.

② Rated voltage symbol

Write down the rated voltage itself ; however, write 2R5 for 2.5V, 6 for 6.3V.

③ Rated capacitance symbol

The symbol denoting nominal capacitance shall consist of three numerals. The first and second numerals shall represent the significant figures of nominal capacitance in the unit of microfarad (μF). And the third numeral shall represent the number of zeros following the significant figures. A decimal point is expressed with "R."

Example

| Rated capacitance (μF) | Symbol |
|------------------------|--------|
| 0.1 | R10 |
| 1 | 010 |
| 2.2 | 2R2 |
| 33 | 330 |
| 100 | 101 |
| 2200 | 222 |
| 33000 | 333 |
| 470000 | 474 |

④ Capacitance tolerance symbol

Example

| Capacitance tolerance | Symbol |
|-----------------------|--------|
| ±10% | K |
| ±20% | M |
| -10 to +30% | Q |
| -10 to +50% | T |

⑤ Casing symbol

Please refer to the page of each series.

⑥ Optional symbol

Plating or others are expressed.

Example

| Symbol | Contents |
|--------|--|
| # | Sn 100% plating +PET sleeve (lead terminal type) |
| U | Sn-Bi plating (chip type) |
| T | Sn 100% plating (chip type) |
| Q | Based on AEC-Q200 |
| N | Based on AEC-Q200 |

⑦ Taping, Lead-forming symbol

Write down one of the forming symbols given on page 14 to 17 for taping and lead-forming capacitors. When taping or lead-forming is not necessary, leave the boxes blank.

Recommended land pattern and size

(Vertical chip type)

● Standard type

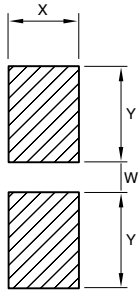

(Unit : mm)

| Case Size φD×L | Land Size | | | Thickness of Solder paste |
|---------------------------|-----------|------|------|------------------------------|
| | X | Y | W | |
| 3×5.3 | 1.6 | 2.2 | 0.8 | 0.15 |
| 4×4.5, 5.3, 5.7, 5.8 | 1.6 | 2.6 | 1.0 | 0.15 |
| 5×4.0, 4.5, 5.3, 5.7, 5.8 | 1.6 | 3.0 | 1.4 | 0.15 |
| 6.3×4.5, 5.3, 5.7, 5.8 | 1.6 | 3.6 | 1.9 | 0.15 |
| 6.3×7.7 | 1.6 | 3.6 | 1.9 | 0.15 |
| 8×6.5, 6.7, 7.7, 8.7 | 1.6 | 4.0 | 2.1 | 0.15 |
| 8×10, 10.5 | 2.5 | *3.5 | *3.0 | 0.15 |
| 10×7.7, 8.7, 10, 10.5 | 2.5 | *4.0 | *4.0 | 0.15 |
| 12.5×13.5 | 3.2 | 6.0 | 4.0 | 0.15 |

* For Vibration resistance use
 φ8×6.5 Y=4.5 W=1.0
 φ8×10, φ8×10.5 Y=4.0 W=2.5
 φ10×10, φ10×10.5 Y=4.5 W=3.0

● For vibration resistance type

RTJ, RTK series

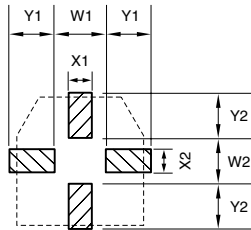

(Unit : mm)

| Case Size φD×L | Land Size | | | | | | Thickness of Solder paste |
|-------------------|-----------|-----|-----|-----|-----|-----|------------------------------|
| | X1 | X2 | Y1 | Y2 | W1 | W2 | |
| 8×10 | 2.5 | 2.5 | 3.0 | 3.5 | 4.0 | 3.0 | 0.20 |
| 10×10.5 | 2.5 | 2.5 | 4.0 | 4.5 | 4.0 | 3.0 | 0.20 |

RTZ, RTD, RTT, HT, HTK series

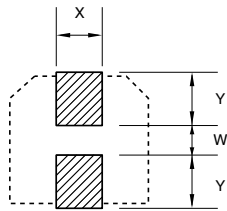

(Unit : mm)

| Case Size φD | Land Size | | | Thickness of Solder paste |
|-----------------|-----------|-----|------|------------------------------|
| | Y | W | X | |
| 8 | 4.0 | 2.5 | 5.0 | 0.20 |
| 10 | 4.8 | 3.6 | 5.0 | 0.20 |
| 12.5 | 6.6 | 3.2 | 7.0 | 0.20 |
| 16 | 7.8 | 5.0 | 10.5 | 0.20 |
| 18 | 8.8 | 5.0 | 10.5 | 0.20 |

(Horizontal chip type)

● □9.5×24.0 (8 pin type)

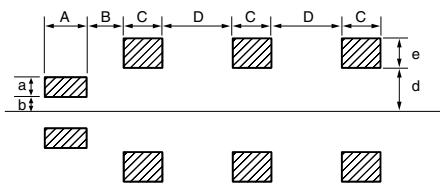

(Unit : mm)

| | 8 pin |
|------------------------------|-------|
| A | 4.0 |
| B | 1.0 |
| C | 3.0 |
| D | 5.5 |
| a | 1.5 |
| b | 1.0 |
| d | 3.0 |
| e | 2.0 |
| Thickness of Solder paste | 0.15 |

● □9.5×19.0 (6 pin type)

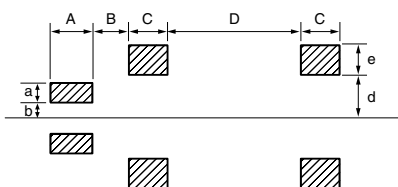

(Unit : mm)

| | 6 pin |
|------------------------------|-------|
| A | 4.0 |
| B | 1.0 |
| C | 3.0 |
| D | 9.0 |
| a | 1.5 |
| b | 1.0 |
| d | 3.0 |
| e | 2.0 |
| Thickness of Solder paste | 0.15 |

NOTE : Design, Specifications are subject to change without notice.
 It is recommended that you shall obtain technical specifications
 from ELNA to ensure that the component is suitable for your use.

■ Recommended soldering conditions

● Aluminum electrolytic capacitors (Lead free)

(1) Soldering iron conditions

Iron tip temperature shall be $400^{\circ}\text{C} \pm 5^{\circ}\text{C}$ within the duration of $3^{\frac{1}{2}}$ seconds.

(2) Flow soldering conditions

The recommendation soldering conditions of the product in which flow soldering is possible are as graph.

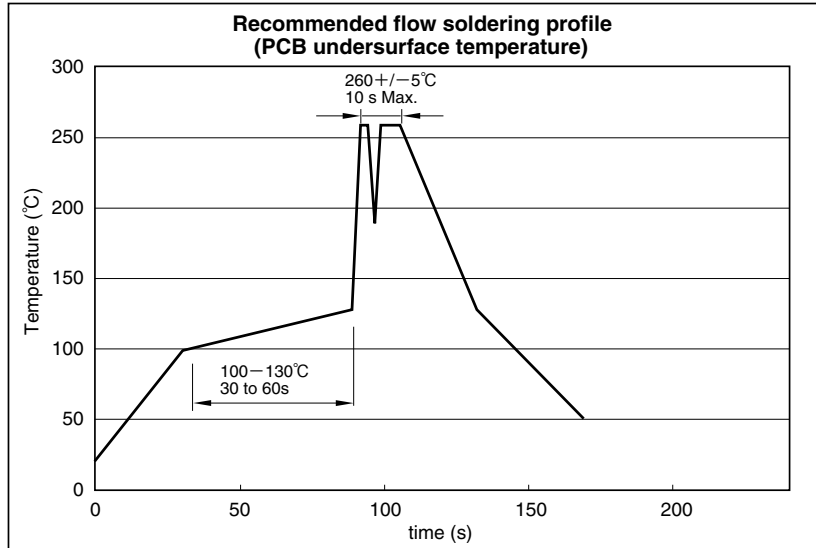

Caution for Using aluminum Electrolytic Capacitors

- (1) Do not dip the capacitor into melted solder.
- (2) Do not flux other part than the terminals.
- (3) If there is a direct contact between the sleeve of the capacitor and the printed circuit pattern or a metal part of another component such as a lead wire, it may cause shrinkage or crack.
- (4) If the application is for extended use, understand and manage the soldering characteristics to avoid abnormal current caused by a contact failure between the capacitor and the PCB.
- (5) Please refer to cautions for using on page 48 to 51 and product specifications about other notes.

■ Recommended soldering conditions

● Chip type aluminum electrolytic capacitors (Lead free)

- (1) Soldering iron conditions
Iron tip temperature shall be 400°C±5°C within the duration of 3¹/₂ seconds.
- (2) Reflow soldering conditions

Profile

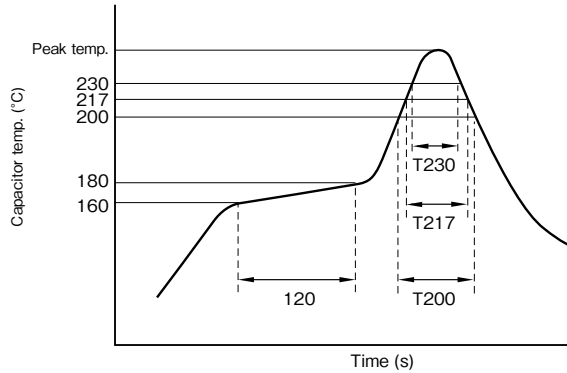

- 1. Preheating shall be under 180°C within 120 seconds.
- 2. Peak temperature shall be within the following table.
- 3. For conditions exceeding the tolerances, consult with us.

T200 : Duration while capacitor head temperature exceeds 200°C (s)
 T217 : Duration while capacitor head temperature exceeds 217°C (s)
 T230 : Duration while capacitor head temperature exceeds 230°C (s)
 The measurement temperature point is the case top.

| Series | Size | Peak temp. (5sec or less) | T230 | T217 | T200 | Reflow cycle |
|--|----------------|---------------------------|--------------|--------------|--------------|-----------------|
| RV5, RVB, RVE, RVS, RVL, RVR, RVC, RVD, RZD, RVV, RVZ, RZF, RZE, RVT, RVX, RVI, RV, RV2, RV3, HV, HVK, HT, HTK, PVG, PVX, PV3, PV2, PVM, PVK, PVS, PVH | φ 4 to φ 6.3 | 250°C Max. | 40 sec. max. | 50 sec. max. | 60 sec. max. | 2 times or less |
| | φ 8 to φ 10 | 240°C Max. | 40 sec. max. | 50 sec. max. | 60 sec. max. | 2 times or less |
| | φ 12.5 | 240°C Max. | 20 sec. max. | 30 sec. max. | 50 sec. max. | 2 times or less |
| RV4 | φ 4 to φ 5 | 250°C Max. | 40 sec. max. | 50 sec. max. | 60 sec. max. | 2 times or less |
| | φ 6.3 | 240°C Max. | 40 sec. max. | 50 sec. max. | 60 sec. max. | 2 times or less |
| RVJ, RVK | φ 8 to φ 10 | 240°C Max. | 40 sec. max. | 50 sec. max. | 60 sec. max. | 2 times or less |
| | φ 12.5 | 230°C Max. | — | 20 sec. max. | 30 sec. max. | 2 times or less |
| RZA, RZB, RZC | φ 4 to φ 6.3 | 260°C Max. | 40 sec. max. | 90 sec. max. | — | 2 times or less |
| | φ 8 to φ 10 | 250°C Max. | 40 sec. max. | 90 sec. max. | — | 2 times or less |
| RTZ, RTD, RTT | φ 8 to φ 10 | 250°C Max. | 30 sec. max. | 60 sec. max. | 80 sec. max. | 2 times or less |
| | φ 12.5 to φ 18 | 240°C Max. | 20 sec. max. | 30 sec. max. | 50 sec. max. | 2 times or less |
| RTK, RYK, RTJ | — | 230°C Max. | — | 20 sec. max. | 30 sec. max. | 2 times or less |

*Please ensure that the capacitor became cold enough to the room temperature (5 to 35°C) before the second reflow.

■ Taping

■ Carrier tape dimension (taping polarity R)

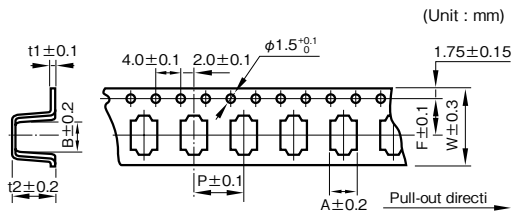

● Series RYK, RV, RVJ, RVZ, RVK (φ12.5), RTZ, RTD, RTT (φ12.5 to 18)

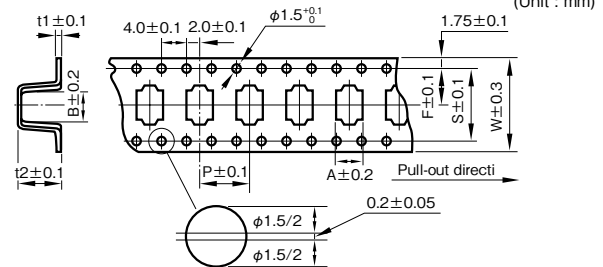

■ Taping polarity

(The all series except RVB and RYK)

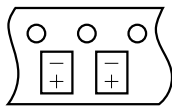

(Series RYK)

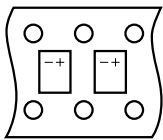

(Unit : mm)

| Outside size φD×L | W | A | B | P | t2 | F | t1 | S |
|----------------------|----|------|------|-----|------|------|-----|------|
| 3×5.3 | 12 | 3.4 | 3.4 | 8.0 | 5.9 | 5.5 | 0.4 | — |
| 4×4.5 | 12 | 4.7 | 4.7 | 8.0 | 4.8 | 5.5 | 0.4 | — |
| 4×5.3 | 12 | 4.7 | 4.7 | 8.0 | 5.8 | 5.5 | 0.4 | — |
| 4×5.7, 5.8 | 12 | 4.7 | 4.7 | 8.0 | 6.2 | 5.5 | 0.4 | — |
| 5×4.0 | 12 | 5.7 | 5.7 | 12 | 4.3 | 5.5 | 0.4 | — |
| 5×4.5 | 12 | 5.7 | 5.7 | 12 | 4.8 | 5.5 | 0.4 | — |
| 5×5.3 | 12 | 5.7 | 5.7 | 12 | 5.8 | 5.5 | 0.4 | — |
| 5×5.7, 5.8 | 12 | 5.7 | 5.7 | 12 | 6.2 | 5.5 | 0.4 | — |
| 6.3×4.5 | 16 | 7.0 | 7.0 | 12 | 4.8 | 7.5 | 0.4 | — |
| 6.3×5.3 | 16 | 7.0 | 7.0 | 12 | 5.8 | 7.5 | 0.4 | — |
| 6.3×5.7, 5.8 | 16 | 7.0 | 7.0 | 12 | 6.2 | 7.5 | 0.4 | — |
| 6.3×7.7 | 16 | 7.0 | 7.0 | 12 | 8.3 | 7.5 | 0.4 | — |
| 8×6.5 | 16 | 8.7 | 8.7 | 12 | 6.8 | 7.5 | 0.4 | — |
| 8×6.7 | 24 | 8.7 | 8.7 | 12 | 7.2 | 11.5 | 0.4 | — |
| 8×8.7 | 24 | 8.7 | 8.7 | 16 | 9.5 | 11.5 | 0.4 | — |
| 8×10 | 24 | 8.7 | 8.7 | 16 | 11 | 11.5 | 0.4 | — |
| 8×10.5 | 24 | 8.7 | 8.7 | 16 | 11.5 | 11.5 | 0.4 | — |
| 10×7.7 | 24 | 10.7 | 10.7 | 16 | 8.2 | 11.5 | 0.4 | — |
| 10×8.7 | 24 | 10.7 | 10.7 | 16 | 9.5 | 11.5 | 0.4 | — |
| 10×10 | 24 | 10.7 | 10.7 | 16 | 11 | 11.5 | 0.4 | — |
| 10×10.5 | 24 | 10.7 | 10.7 | 16 | 11.5 | 11.5 | 0.4 | — |
| * 12.5×13.5 | 32 | 13.4 | 13.4 | 24 | 14.5 | 14.2 | 0.5 | 28.4 |
| * 16×16.5 | 44 | 17 | 17 | 28 | 17.5 | 20.2 | 0.5 | 40.4 |
| * 16×21.5 | 44 | 17 | 17 | 28 | 22.5 | 20.2 | 0.5 | 40.4 |
| * 18×16.5 | 44 | 19 | 19 | 32 | 17.5 | 20.2 | 0.5 | 40.4 |
| * 18×21.5 | 44 | 19 | 19 | 32 | 22.5 | 20.2 | 0.5 | 40.4 |
| * 9.5×19.0 | 44 | 9.9 | 22.9 | 16 | 9.5 | 20.2 | 0.4 | 40.4 |
| * 9.5×24.0 | 44 | 9.9 | 27.9 | 16 | 9.5 | 20.2 | 0.4 | 40.4 |

■ Reel dimension

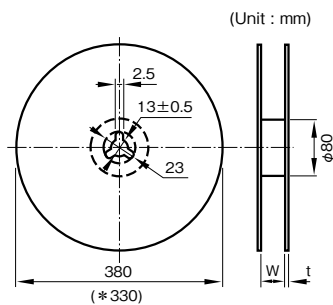

■ Reel material

Card board : symbol R
Polystyrene : symbol R2

(Unit : mm)

| Outside size φD×L | Reel dimension | |
|----------------------|----------------|---|
| | W | t |
| 3, 4 | 14 | 3 |
| 5 | 14 | 3 |
| 6.3 | 18 | 3 |
| 8×6.5 | 18 | 3 |
| 8×6.7 | 26 | 3 |
| 8, 10 | 26 | 3 |
| * 12.5 | 34 | 3 |
| * 16 | 46 | 3 |
| * 18 | 46 | 3 |
| * 9.5×19.0 | 45 | 3 |
| * 9.5×24.0 | 45 | 3 |

■ Packing quantity (Reel)

| Outside size φD×L | Quantity (PCS.) |
|----------------------|-----------------|
| 3, 4 | 2000 |
| 5, 6.3 | 1000 |
| 8×6.5 | 1000 |
| 8×6.7 | 1000 |
| * 8, 10 | 500 |
| * 12.5×13.5 | 200 |
| * 16×16.5 | 125 |
| * 16×21.5 | 75 |
| * 18×16.5 | 125 |
| * 18×21.5 | 75 |
| * 9.5×19.0 | 400 |
| * 9.5×24.0 | 400 |

Lead Forming

• In order to facilitate insertion into printed circuit board, lead wires are cut or formed.

Product Size Table

Unit: mm

| Forming name | Lead forming symbol | Dimension | | Style | Outline drawing |
|-------------------------------|---------------------|----------------|--------------------|-------|-----------------|
| | | F (Lead pitch) | φD (Case diameter) | | |
| Forming cut | F10 | 2.0 | 4 | B | |
| | F1 | | 5 | A | |
| | F12 | 2.5 | 4 to 5 | B | |
| | F1 | | 6.3 | A | |
| | F1 | 3.5 | 8 | A | |
| | F4 | | 4 to 8 | B | |
| | F | 5.0 | 4 to 8 | B | |
| | F | | 10 to 12.5 | A | |
| F | 7.5 | 16 to 18 | A | | |
| Snap-in | S1 | 5.0 | 4 to 8 | B | |
| | S1 | | 10 to 12.5 | A | |
| | S1 | 7.5 | 16 to 18 | A | |
| Forming cut (restrict series) | F49 | 5.0 | 10 to 12.5 | B | |
| | F51 | | 10 to 12.5 | | |
| | F58 | | 10 | | |
| | F49 | 7.5 | 16 to 18 | | |
| | F51 | | 16 to 18 | | |

| Forming name | Lead forming symbol | Dimension | | | | Outline drawing |
|----------------------------|---------------------|----------------|--------------------|----------------|----------------|-----------------|
| | | F (Lead pitch) | φD (Case diameter) | ℓ ₀ | ℓ ₁ | |
| For 90° side mount of case | G9, G10 | 3.5 | 8 | 5.5 | 1.0 | |
| | G59, G60 | | 8 | 3.6 | 1.0 | |
| | G9, G10 | 5.0 | 10 to 12.5 | 5.5 | 1.0 | |
| | G55, G56 | | 12.5 | 7.5 | 2.5 | |
| | G59, G60 | | 10 to 12.5 | 3.6 | 1.0 | |
| | G95, G96 | | 12.5 | 0.95 | 4.9 | |
| | G99, GA0 | 10 | 1.0 | 1.9 | | |
| | GAS, GAT | | 10 to 12.5 | 4.5 | 1.0 | |
| | G9, G10 | 7.5 | 16 to 18 | 5.5 | 1.0 | |
| | GAS, GAT | | 16 to 18 | 4.5 | 1.0 | |

NOTE : Design, Specifications are subject to change without notice. It is recommended that you shall obtain technical specifications from ELNA to ensure that the component is suitable for your use.

Taping

• For automatic insertion (radial lead type)

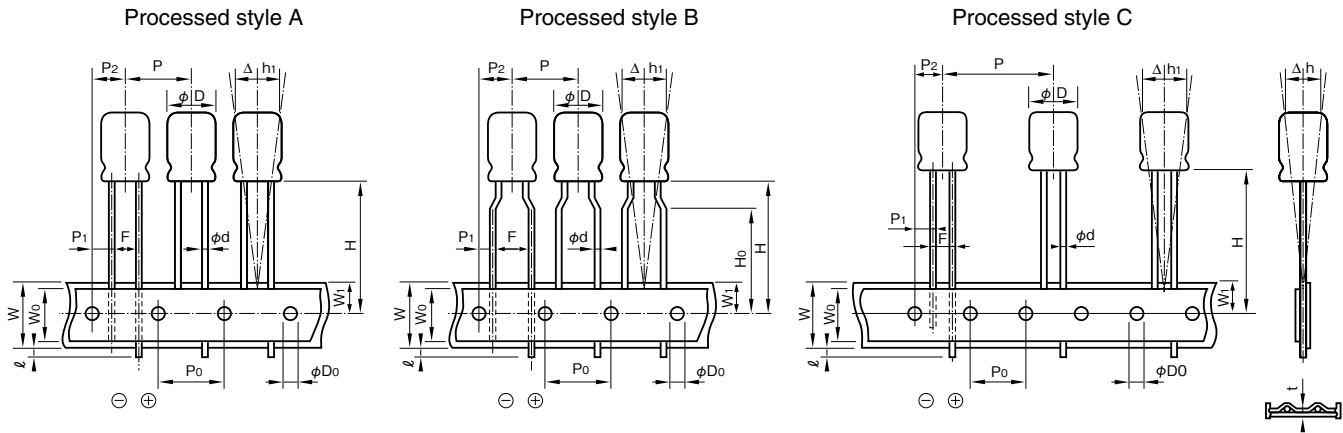

*The shape of a lead wire sandwiched by the mounting strips may differ from the ones shown in the figures.

Product Size Table

Unit: mm

| Item | Symbol | Tolerance | 5L to 8L | |
|--------------------------------------|----------------|---------------|---|----------------------|
| | | | $\phi 3$ to $\phi 8$ (except $\phi 8 \times 7L$) | $\phi 4$ to $\phi 8$ |
| Lead forming symbol | — | — | T36 | T58 |
| Style | — | — | A or B | |
| Lead-wire diameter | ϕd | ± 0.05 | 0.4 or 0.45 | |
| Lead to lead distance | F | +0.8 -0.2 | 2.5 | 5.0 |
| Height of component from tape center | H | +0.75 -0.5 | 18.5 | 17.5 |
| Lead-wire clinch height | H ₀ | ± 0.5 | — | 16.0 |
| Pitch of component | P | ± 1.0 | 12.7 | |
| Feed hole pitch | P ₀ | ± 0.3 | 12.7 | |
| Hole center to lead | P ₁ | ± 0.5 | 5.1 | 3.85 |
| Hole center to component | P ₂ | ± 1.0 | 6.35 | |
| Tape width | W | ± 0.5 | 18.0 | |
| Hold down tape width | W ₀ | Min. | 6.0 | |
| Feed hole position | W ₁ | ± 0.5 | 9.0 | |
| Max. lead protrusion | l | Max. | 1.0 | |
| Feed hole diameter | ϕD_0 | ± 0.2 | 4.0 | |
| Alignment of component to center | Δh | ± 1.0 | 0 | |
| Alignment of component to center | Δh_1 | ± 1.0 | 0 | |
| Total tape thickness | t | ± 0.2 | 0.7 | |

■ Taping

• For automatic insertion (radial lead type)

Product Size Table

Unit: mm

| Item | Symbol | Tolerance | 11L to 25L | | | | | |
|--------------------------------------|-----------------|--------------------------|------------|------|------|------|------|-------|
| | | | φ5, φ6.3 | | | φ8 | φ10 | φ12.5 |
| Lead forming symbol | — | — | T36 | T58 | T2 | T2 | T2 | T4 |
| Style | — | — | A or B | | B | | A | |
| Lead-wire diameter | φd | ±0.05 | 0.5 or 0.6 | | | 0.6 | | |
| Lead to lead distance | F | +0.8 -0.2 | 2.5 | | 5.0 | | | |
| Height of component from tape center | H | +0.75 -0.5 | 18.5 | 17.5 | 18.5 | 20.0 | 18.5 | |
| Lead-wire clinch height | H ₀ | ±0.5 | — | | 16.0 | | — | |
| Pitch of component | P | ±1.0 | 12.7 | | | | | 15.0 |
| Feed hole pitch | P ₀ | ±0.3 | 12.7 | | | | | 15.0 |
| Hole center to lead | P ₁ | +0.5 (10 to φ18 ±0.7) | 5.1 | | 3.85 | | | 5.0 |
| Hole center to component | P ₂ | ±1.0 | 6.35 | | | | | 7.5 |
| Tape width | W | ±0.5 | 18.0 | | | | | |
| Hold down tape width | W ₀ | Min. | 6.0 | | | | | |
| Feed hole position | W ₁ | ±0.5 | 9.0 | | | | | |
| Max. lead protrusion | ℓ | Max. | 1.0 | | | | | |
| Feed hole diameter | φD ₀ | ±0.2 | 4.0 | | | | | |
| Alignment of component to center | Δh | ±1.0 | 0 | | | | | |
| Alignment of component to center | Δh ₁ | ±1.0 | 0 | | | | | |
| Total tape thickness | t | ±0.2 | 0.7 | | | | | |

Part numbering system (example: Series RJB, 10V470μF, 5mm pitch taping)

| | | | | | | | | | |
|-------------|---|----------------------|---|--------------------------|------------------------------|---------------|---|---|---------------|
| RJB | — | 10 | V | 471 | M | G3 | # | — | T2 |
| Series code | | Rated voltage symbol | | Rated capacitance symbol | Capacitance tolerance symbol | Casing symbol | | | Taping symbol |

Standard packing specification of aluminum electrolytic capacitors (taping article)

| Classification | Chip type | |
|----------------|----------------------------------|---|
| | Aluminum electrolytic capacitors | Polymer hybrid type aluminum electrolytic capacitors, Aluminium electrolytic capacitors with conductive polymer solid electrolyte |
| Packing style | <p>Reel</p> <p>Inner box</p> | <p>Reel</p> <p>Dampproof bag</p> <p>Inner box</p> |

| Classification | Lead terminal type |
|----------------|----------------------------------|
| Packing style | <p>Flat box</p> <p>Inner box</p> |

Please inquire for details.

■ Standard packing specification of aluminum electrolytic capacitors
(long lead, lead forming)

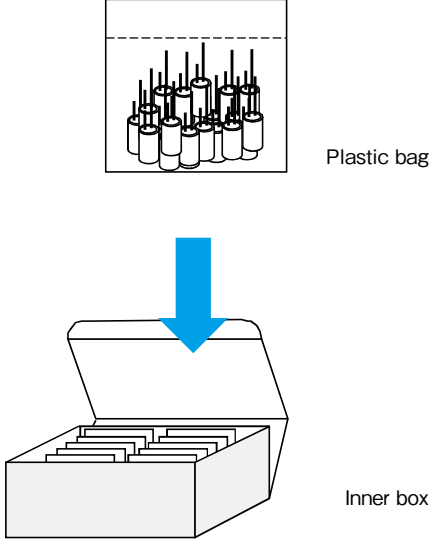
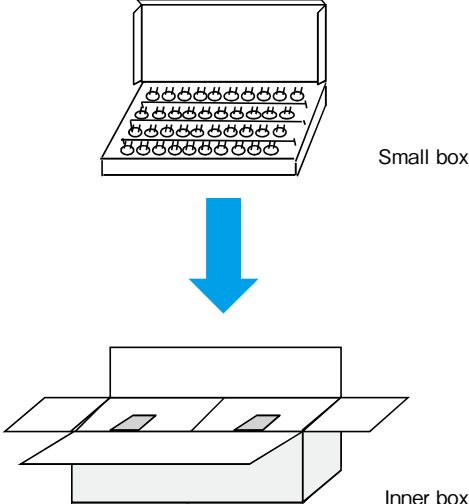
| | | |
|---------------|--|--|
| Size | Long lead, Lead forming of ϕ 10 or less (Standard packing) | Lead forming of ϕ 12.5 or more (Standard packing) |
| Packing style |  <p>Plastic bag</p> <p>Inner box</p> |  <p>Small box</p> <p>Inner box</p> |

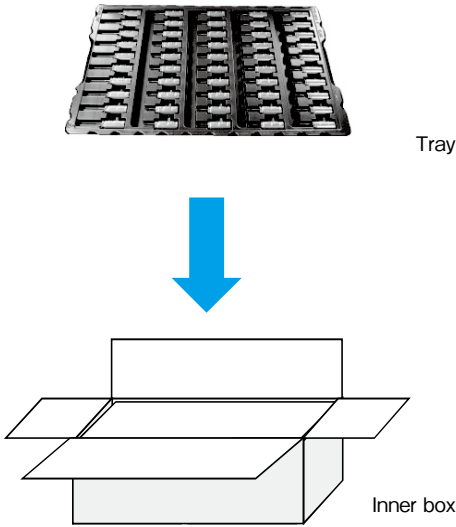
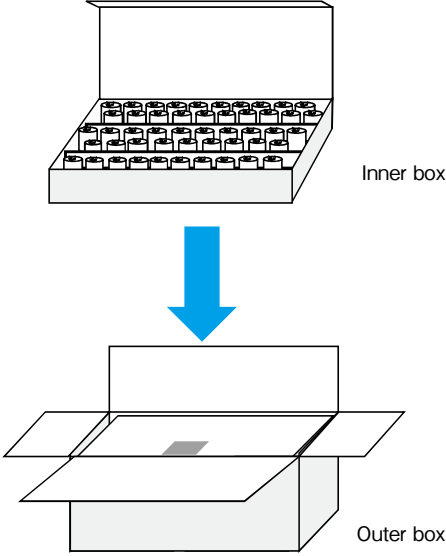
| | | |
|---------------|--|--|
| Size | ϕ 10 to ϕ 22 (Optional packing) | ϕ 22 or more (Standard packing) |
| Packing style |  <p>Tray</p> <p>Inner box</p> |  <p>Inner box</p> <p>Outer box</p> |

Please inquire for details.

MEMO

**Conductive Polymer hybrid aluminum
Electrolytic Capacitors,
Aluminum Electrolytic Capacitors With
Conductive Polymer Solid Electrolyte**

■ Cautions for Using Aluminum Electrolytic Capacitors With Conductive Polymer Solid Electrolyte

Please be sure to read this specification before using this product.

Before placing an order, please inquire about the Product Specification to check details.

■ Cautions for Usage

1. Solid conductive polymer aluminum electrolytic capacitors are polarized.

- Using a capacitor with reversed polarity causes abnormal current flow, resulting in a short circuit.
- Cannot use for the circuit to which the polarity reverses by ripple voltage.

2. Prohibited Circuits

- Since leakage current problem may arise, capacitors cannot be used in the following circuits.
 - ① Coupling circuits
 - ② Circuits greatly affected by leakage current

3. Use capacitors within the rated voltage.

- The application of voltages exceeding the rated voltage can significantly increase leakage current, resulting in a short failure. Please do not apply a voltage exceeding the rated voltage.

4. Be careful of excessive rush current.

- Using capacitors in the circuit where excessive rush current passes may cause characteristic deterioration or a short. When the rush current exceeds 10 A, we recommend use of protection circuits to ensure high reliability.

5. Use the allowable ripple voltage and the rated ripple current below the specified values.

- When superimposing a ripple voltage on a DC bias voltage, exercise care that the peak voltage value does not exceed the rated voltage and does not reverse the polarity.
- The rated ripple current shall be below the specified value.

6. Changes in characteristics due to operating temperature

- The characteristics of solid conductive polymer aluminum electrolytic capacitors vary by temperature as follows. These variations are temporary and recover when the temperature goes back (except for the case of characteristic deterioration because of high temperatures over a long time). Note that using capacitors over the upper category temperature increases leakage current, resulting in a short and destruction.

Be careful of the capacitor temperature considering not only the ambient temperature where the equipment is placed and the temperature inside the equipment but also radiation heat from the heating element inside the equipment, and self-heat

generation by ripple current.

- ① Capacitance expressed in the value at 20°C, 120 Hz increases with increased temperature and decreases with decreasing temperature.
- ② Tangent of loss angle ($\tan\delta$) expressed in the value at 20°C, 120 Hz is temperature-independent.
- ③ Equivalent series resistance (ESR) expressed in the value at 20°C, 100 kHz is temperature independent.
- ④ Leakage current increases with increased temperature and decreases with decreasing temperature.

7. Changes in characteristics due to frequency

- The characteristics of solid conductive polymer aluminum electrolytic capacitors vary by operating frequency as follows.
 - ① Capacitance expressed in the value at 20°C, 120 Hz decreases with increased frequency.
 - ② Tangent of loss angle ($\tan\delta$) expressed in the value at 20°C, 120 Hz increases with increased frequency.
 - ③ Equivalent series resistance (ESR) expressed in the value at 20°C, 100 kHz increases with decreasing frequency.

8. Failure modes of solid conductive polymer aluminum electrolytic capacitors

- The failure modes of solid conductive polymer aluminum electrolytic capacitors are a wear-out failure by deterioration of electrical performance and a random failure by a short. The failure rate level is 0.5%/1,000h at the reliability level of 60% with the specified voltage applied at 105°C.
- If a short occurs and continues with the application of a voltage exceeding the rated voltage, increasing the internal temperature, the internal pressure increases by vaporization of the cathode material, which may cause the aluminum case to come off.

9. Operating environments

- Do not use capacitors in an environment directly exposed to water, saltwater spray, oil spill or condensation.
- Do not use capacitors in an environment filled with toxic gas such as hydrogen sulfide, sulfurous acid, nitrous acid, chlorine, ammonia, etc.
- Do not use capacitors in a place exposed to ozone, ultraviolet rays, or radiation.

10. Fumigation Process

NOTE : Design, Specifications are subject to change without notice.
It is recommended that you shall obtain technical specifications from ELNA to ensure that the component is suitable for your use.

- Before transportation of electronic equipment to overseas, fumigation process may be subjected to wooden packing material with a halogen (compound) gas such as methyl bromide. Exercise care that this halogen gas may corrode capacitors. Also, be careful of epidemic preventive agent as corrosive component such as halogen may be contained.

11. The case of solid conductive polymer aluminum electrolytic capacitors and the cathode terminal are not insulated.

- The case and the cathode terminal are not insulated as being connected through inconstant resistance.

12. Double-sided PCB's

- When using capacitors on a double-sided PCB, exercise care that the wiring pattern does not touch the area where the capacitors are mounted. Failure to do so may cause a short to occur to the PCB depending on the mounting conditions.

13. Regarding Connection of Solid Conductive Polymer Aluminum Electrolytic Capacitors

- When connecting more than one capacitor in parallel, consider the current balance.

14. Use at a high altitude

- The use of capacitors at high altitudes such as on an airplane causes a large difference between the internal pressure of the capacitors and the atmospheric pressure. However, there is no problem in use under atmospheric pressure up to about an altitude of 10,000 meters.

If the condition is severe like space, please contact us.

15. Other Notes

- Do not use capacitors on a circuit where rapid charge and discharge are repeated.
- Electrical characteristics of capacitors vary by variations in temperature and frequency. Please consider these variations when designing a circuit.

■Cautions for Mounting

1. Cautions for Mounting

- Do not reuse capacitors that have been assembled in a set and energized. Capacitors cannot be reused except for those which have been measured on electrical performance during periodic inspection.
- Before mounting, confirm the capacitor ratings (rated capacitance and rated voltage).
- Capacitors may generate transient recovery voltage. In this case, discharge through a resistor of about 1 kΩ.
- Before mounting, confirm the polarity of capacitor.

- Do not drop capacitors onto a floor nor use them.
- Do not mount deformed capacitors.
- Do not mount heating parts around capacitors and on the back of the PCB under or back of capacitors).

2. Do not apply excessive pressure to the capacitor or its terminals

- Be careful of the shock force that can be produced by absorbers, product checkers, and centering on automatic inserters and installers.

3. Soldering

- Do not solder capacitor body by dipping into melted solder.
- Soldering conditions (preheating, soldering temperature, terminal dipping time) should be within the ranges specified in the catalog or the delivery specification. Please refer to 13 page.
- Flux should not adhere to the parts other than the terminals.
- When using a soldering iron, avoid excessive stress to capacitor body.
- Although leakage current may increase (from a few μA to hundreds of μA) after soldering, it can be reduced through self-repair by applying voltage. It is advised to operate the set properly after treating with the recommended voltage.
- In case of a long-term use of equipment, control the soldering characteristics so that capacitors and PCB do not fail to connect to avoid abnormal current passage by a failure of soldering to mount.

4. Handling after Soldering

- Do not tilt, fall, raise or twist capacitor body.
- Do not pick up or move PCB by holding a capacitor.
- Do not bump capacitors against objects. When stacking PCB's, make sure that capacitors do not touch the PCB's or other components.
- Do not subject capacitors to excessive stress.

5. Cleaning after Soldering

- Recommended cleaning method
 - ①Cleaning solutions:
 - (a) CLEANTHROUGH 710M, 750H, 750L
 - (b) PINEALPHA ST-100S
 - (c) Techno Care FRW-4~17
 - (d) Isopropyl alcohol (2-propanol)
 - ②Cleaning conditions:
 - (a) The temperature of cleaning solution shall be less than 60°C.
 - (b) Use immersion or ultrasonic waves within two minutes.

(c) After cleaning, capacitors and PCB's shall thoroughly be rinsed and dried with hot blast for more than 10 minutes. The temperature of such breeze should be less than the upper category temperature.

(d) After cleaning, do not keep capacitors in cleaning solution atmosphere or airtight containers.

- During cleaning, control the cleaning solution against contamination.

6. Fixing adhesives and coating materials.

- Do not use halogenated fixatives and coatings.
- Before using a fixative or coating, remove flux residues and contaminants from between the PCB and the sealing section of capacitors.
- Dry the cleaning solution before using the adhesive or coating.
- Do not cover up all the sealing sections (terminal side) of capacitors with the adhesive or coating.
- Heat curing conditions of fixative and coating.

■ Other Cautions

1. Do not directly touch the terminals of solid conductive polymer aluminum electrolytic capacitors.

Failure to do so can cause electric shock or burns. Before use, allow capacitors to discharge through a 1kΩ resistor (with a sufficient margin to the heat generation capacity) as needed.

2. Do not short-circuit between the terminals of the solid conductive polymer aluminum electrolytic capacitors with electric conductor. Do not subject capacitors to conductive solutions such as acid and alkaline water solutions.

3. Periodic inspection should be performed on the capacitors for the industrial equipment application.

Check the following checkpoints.

- Visual inspection to check for significant defects.
- Electrical performance: leakage current, rated capacitance, tangent of loss angle, ESR, and items specified in the catalog or delivery specification.

4. Be careful of the following cases of emergency.

- In case of a short during use of capacitors in sets, producing gas, turn off the main power of the set or unplug the power cord from the outlet.
- In case of a short, producing gas, it may take a few seconds to a few minutes depending on the conditions. Therefore, ensure that the protective circuit of the power supply works during this time.
- If the gas gets in your eyes, rinse them immediately. Gargle if the gas is inhaled.
- Do not lick the electrolyte of capacitors. When the

electrolyte gets on your skin, wash it off with soap immediately.

5. Storage Conditions.

- Do not store at high temperature and high humidity. Store at a temperature of 5 to 35°C and a relative humidity of less than 75%, keeping free from direct sunlight.
- During delivery, capacitors are stored in airtight moistureproof bags to ensure satisfactory soldering. Once the bag is opened right before mounting, it is better to use up the capacitors. If some are unavoidably left over, return them to the moistureproof bag, and seal the opening hermetically.
- Solid conductive polymer aluminum electrolytic capacitors may have increased leakage current when unused or stored for a long time after mounted on equipment. This phenomenon often occurs at high ambient temperatures; however, leakage current will decrease through voltage treatment. If leakage current still increases after a lapse of more than one year at ambient temperature (shorter time at high temperatures), treat with voltage as needed. In design of equipment, consider the effect of increase in initial current, and install protective circuits as needed.

Please check that recommended voltage treatment conditions are provided for each series.

- Do not store capacitors in an environment directly exposed to water, saltwater spray, oil spill or condensation.
- Do not store capacitors in an environment filled with toxic gas such as hydrogen sulfide, sulfurous acid, nitrous acid, chlorine, ammonia, etc.
- Do not store capacitors in a place exposed to ozone, ultraviolet rays, or radiation.

6. Please take the following actions when disposing of solid conductive polymer aluminum electrolytic capacitors.

- Entrust to specialists of industrial waste treatment for incineration.

7. Others

- Before using capacitors, check the details of this delivery specification and catalog as well as the following.

Technical Report of Japan Electronics and Information Technology Industries Association
EIAJ RCR-2367B

Guideline of notabilia for fixed aluminum electrolytic capacitors for use in electronic equipment

MEMO

Conductive Polymer Hybrid Capacitors

GREEN
CAP

SMD

Low
ESR105°C
5000hours

- Low E.S.R. and high ripple current are realized.
- Equivalent to conductive polymer type Aluminum Electrolytic Capacitor.
(There are little characteristics change by temperature and frequency)
- Guaranteed 105°C, 5000 hours.

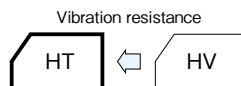

Marking color : Blue print

Specifications

| Item | Performance | | | | | | | | | | | | |
|---|---|------------------------|---------------|-----------------|-------------------------------------|----------------------------------|------------------------------|---------------------------|---|---------------|---|------|------|
| Category temperature range (°C) | -55~+105 | | | | | | | | | | | | |
| Tolerance at rated capacitance (%) | ±20 (20°C, 120Hz) | | | | | | | | | | | | |
| Leakage current (µA) | Less than 0.01CV or 3(µA) whichever is larger (after 2 minutes) C : Rated capacitance (µF) ; V : Rated voltage (V) (20°C) | | | | | | | | | | | | |
| Tangent of loss angle (tanδ) | <table border="1"> <thead> <tr> <th>Rated voltage (V)</th> <th>25</th> <th>35</th> <th>50</th> <th>63</th> <th>80</th> </tr> </thead> <tbody> <tr> <td>tanδ (max.)</td> <td>0.14</td> <td>0.12</td> <td>0.10</td> <td>0.08</td> <td>0.08</td> </tr> </tbody> </table> (20°C, 120Hz) | Rated voltage (V) | 25 | 35 | 50 | 63 | 80 | tanδ (max.) | 0.14 | 0.12 | 0.10 | 0.08 | 0.08 |
| Rated voltage (V) | 25 | 35 | 50 | 63 | 80 | | | | | | | | |
| tanδ (max.) | 0.14 | 0.12 | 0.10 | 0.08 | 0.08 | | | | | | | | |
| Characteristics at high and low temperature | <table border="1"> <thead> <tr> <th>Impedance ratio (max.)</th> <th>Z-25°C/Z+20°C</th> <th>1.5</th> </tr> </thead> <tbody> <tr> <td></td> <th>Z-55°C/Z+20°C</th> <td>2.0</td> </tr> </tbody> </table> (100kHz) | Impedance ratio (max.) | Z-25°C/Z+20°C | 1.5 | | Z-55°C/Z+20°C | 2.0 | | | | | | |
| Impedance ratio (max.) | Z-25°C/Z+20°C | 1.5 | | | | | | | | | | | |
| | Z-55°C/Z+20°C | 2.0 | | | | | | | | | | | |
| Endurance (105°C) (Applied ripple current) | <table border="1"> <thead> <tr> <th>Test time</th> <td>5000 hours</td> </tr> </thead> <tbody> <tr> <td>Leakage current</td> <td>The initial specified value or less</td> </tr> <tr> <td>Percentage of capacitance change</td> <td>Within ±30% of initial value</td> </tr> <tr> <td>Tangent of the loss angle</td> <td>200% or less of the initial specified value</td> </tr> <tr> <td>E.S.R. change</td> <td>200% or less of the initial specified value</td> </tr> </tbody> </table> | Test time | 5000 hours | Leakage current | The initial specified value or less | Percentage of capacitance change | Within ±30% of initial value | Tangent of the loss angle | 200% or less of the initial specified value | E.S.R. change | 200% or less of the initial specified value | | |
| Test time | 5000 hours | | | | | | | | | | | | |
| Leakage current | The initial specified value or less | | | | | | | | | | | | |
| Percentage of capacitance change | Within ±30% of initial value | | | | | | | | | | | | |
| Tangent of the loss angle | 200% or less of the initial specified value | | | | | | | | | | | | |
| E.S.R. change | 200% or less of the initial specified value | | | | | | | | | | | | |
| Shelf life (105°C) | Test time : 1000hours ; other items are the same as those for the endurance. Voltage application treatment | | | | | | | | | | | | |

Outline Drawing

Unit : mm

| Series HV | | | | | | | | | Series HT | | | | | | | | |
|----------------------|---------|------|------|-----|------------|-----|---------------|--|----------------------|--------|------|------|-----|------------|-----|---------------|--|
| | | | | | | | | | | | | | | | | | |
| () : Reference size | | | | | | | | | () : Reference size | | | | | | | | |
| φD | L | A | B | C | W | P | Casing symbol | | φD | L | A | B | C | W | P | Casing symbol | |
| 6.3 | 7.7±0.3 | 6.6 | 6.6 | 2.7 | 0.5 to 0.8 | 2.0 | F80 | | 8 | 10±0.5 | 8.4 | 8.4 | 3.0 | 0.7 to 1.1 | 3.1 | G90 | |
| 8 | 8.7±0.3 | 8.4 | 8.4 | 3.0 | 0.5 to 0.8 | 3.1 | G90 | | 8 | 10±0.5 | 8.4 | 8.4 | 3.0 | 0.7 to 1.1 | 3.1 | G10 | |
| 10 | 8.7±0.3 | 10.4 | 10.4 | 3.3 | 0.7 to 1.1 | 4.7 | H90 | | 10 | 10±0.5 | 10.4 | 10.4 | 4.7 | 0.7 to 1.1 | 4.7 | H10 | |
| 10 | 10±0.5 | 10.4 | 10.4 | 3.3 | 0.7 to 1.1 | 4.7 | H10 | | | | | | | | | | |

- Soldering conditions are described on page 13.
- Land pattern size are described on page 11.
- The taping specifications are described on page 14.

Coefficient of Frequency for Rated Ripple Current

| Frequency (Hz) | 120 | 1k | 10k | 100k or more |
|-------------------|------|------|------|--------------|
| Rated voltage (V) | 0.10 | 0.30 | 0.60 | 1 |
| 25 to 80 | | | | |

Part numbering system

HV (example : 35V270µF)

| | | | | | | | | |
|-------------|---|----------------------|---|--------------------------|------------------------------|---------------|---|---------------|
| HV | — | 35 | V | 271 | M | H10 | — | □ |
| Series code | | Rated voltage symbol | | Rated capacitance symbol | Capacitance tolerance symbol | Casing symbol | | Taping symbol |

HT (example : 35V270µF)

| | | | | | | | | |
|-------------|---|----------------------|---|--------------------------|------------------------------|---------------|---|---------------|
| HT | — | 35 | V | 271 | M | H10 | — | □ |
| Series code | | Rated voltage symbol | | Rated capacitance symbol | Capacitance tolerance symbol | Casing symbol | | Taping symbol |

Standard Ratings

| Rated voltage (V) Rated capacitance (µF) | Item | 25 | | | 35 | | | 50 | | | 63 | | | 80 | | |
|---|---------|-----------|-----------|----------------------|-----------|-----------|----------------------|-----------|-----------|----------------------|-----------|-----------|----------------------|-----------|-----------|----------------------|
| | | Case | ESR | Rated ripple current | Case | ESR | Rated ripple current | Case | ESR | Rated ripple current | Case | ESR | Rated ripple current | Case | ESR | Rated ripple current |
| | | φD×L (mm) | (mΩ max.) | (mA rms) | φD×L (mm) | (mΩ max.) | (mA rms) | φD×L (mm) | (mΩ max.) | (mA rms) | φD×L (mm) | (mΩ max.) | (mA rms) | φD×L (mm) | (mΩ max.) | (mA rms) |
| 22 | — | — | — | — | — | — | — | — | — | 6.3×7.7 | 80 | 1500 | 8×10 | 45 | 1550 | |
| 27 | — | — | — | — | — | — | — | — | — | 8×8.7 | 50 | 1600 | — | — | — | |
| 33 | — | — | — | — | — | — | — | 6.3×7.7 | 40 | 1600 | 8×10 | 40 | 1600 | 10×10 | 36 | 1700 |
| 47 | — | — | — | — | — | — | — | 8×8.7 | 35 | 1700 | 10×8.7 | 35 | 1700 | — | — | — |
| 56 | — | — | — | — | — | — | — | — | — | — | 10×10 | 30 | 1800 | — | — | — |
| 68 | — | — | — | 6.3×7.7 | 35 | 2000 | 8×10 | 30 | 1800 | — | — | — | — | — | — | |
| 82 | — | — | — | — | — | — | 10×8.7 | 28 | 1900 | — | — | — | — | — | — | |
| 100 | 6.3×7.7 | 30 | 2000 | 8×8.7 | 30 | 2100 | 10×10 | 28 | 2000 | — | — | — | — | — | — | |
| 150 | 8×8.7 | 27 | 2100 | 8×10 | 27 | 2300 | — | — | — | — | — | — | — | — | — | |
| 220 | 8×10 | 27 | 2300 | 10×8.7 | 25 | 2400 | — | — | — | — | — | — | — | — | — | |
| 270 | 10×8.7 | 25 | 2400 | 10×10 | 20 | 2500 | — | — | — | — | — | — | — | — | — | |
| 330 | 10×10 | 20 | 2500 | — | — | — | — | — | — | — | — | — | — | — | — | |

(Note) Rated ripple current : 105°C , 100Hz ; ESR : 20°C , 100Hz

Conductive Polymer Hybrid Capacitors

GREEN CAP

SMD

Low ESR

125°C
4000hours

- Low E.S.R. and high ripple current are realized.
- Equivalent to conductive polymer type Aluminum Electrolytic Capacitor. (There are little characteristics change by temperature and frequency)
- Guaranteed 125°C, 4000 hours.



Marking color : Blue print

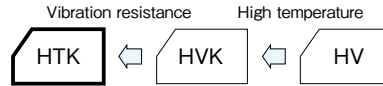

Specifications

| Item | Performance | | | | | | | | | | |
|---|---|------------------------|---------------|-----------------|-------------------------------------|----------------------------------|------------------------------|---------------------------|---|---------------|---|
| Category temperature range (°C) | -55~+125 | | | | | | | | | | |
| Tolerance at rated capacitance (%) | ±20 (20°C, 120Hz) | | | | | | | | | | |
| Leakage current (µA) | Less than 0.01 CV or 3(µA) whichever is larger (after 2 minutes) C : Rated capacitance (µF) ; V : Rated voltage (V) (20°C) | | | | | | | | | | |
| Tangent of loss angle (tanδ) | <table border="1"> <thead> <tr> <th>Rated voltage (V)</th> <th>25</th> <th>35</th> <th>50</th> <th>63</th> </tr> </thead> <tbody> <tr> <td>tanδ (max.)</td> <td>0.14</td> <td>0.12</td> <td>0.10</td> <td>0.08</td> </tr> </tbody> </table> (20°C, 120Hz) | Rated voltage (V) | 25 | 35 | 50 | 63 | tanδ (max.) | 0.14 | 0.12 | 0.10 | 0.08 |
| Rated voltage (V) | 25 | 35 | 50 | 63 | | | | | | | |
| tanδ (max.) | 0.14 | 0.12 | 0.10 | 0.08 | | | | | | | |
| Characteristics at high and low temperature | <table border="1"> <thead> <tr> <th rowspan="2">Impedance ratio (max.)</th> <th>Z-25°C/Z+20°C</th> <td>1.5</td> </tr> <tr> <th>Z-55°C/Z+20°C</th> <td>2.0</td> </tr> </thead> </table> (100kHz) | Impedance ratio (max.) | Z-25°C/Z+20°C | 1.5 | Z-55°C/Z+20°C | 2.0 | | | | | |
| Impedance ratio (max.) | Z-25°C/Z+20°C | | 1.5 | | | | | | | | |
| | Z-55°C/Z+20°C | 2.0 | | | | | | | | | |
| Endurance (125°C) (Applied ripple current) | <table border="1"> <thead> <tr> <th>Test time</th> <td>4000 hours</td> </tr> </thead> <tbody> <tr> <td>Leakage current</td> <td>The initial specified value or less</td> </tr> <tr> <td>Percentage of capacitance change</td> <td>Within ±30% of initial value</td> </tr> <tr> <td>Tangent of the loss angle</td> <td>200% or less of the initial specified value</td> </tr> <tr> <td>E.S.R. change</td> <td>200% or less of the initial specified value</td> </tr> </tbody> </table> | Test time | 4000 hours | Leakage current | The initial specified value or less | Percentage of capacitance change | Within ±30% of initial value | Tangent of the loss angle | 200% or less of the initial specified value | E.S.R. change | 200% or less of the initial specified value |
| Test time | 4000 hours | | | | | | | | | | |
| Leakage current | The initial specified value or less | | | | | | | | | | |
| Percentage of capacitance change | Within ±30% of initial value | | | | | | | | | | |
| Tangent of the loss angle | 200% or less of the initial specified value | | | | | | | | | | |
| E.S.R. change | 200% or less of the initial specified value | | | | | | | | | | |
| Shelf life (125°C) | Test time : 1000hours ; other items are the same as those for the endurance. Voltage application treatment | | | | | | | | | | |

Outline Drawing

Unit : mm

Series HVK

| φD | L | A | B | C | W | P | Casing symbol |
|-----|---------|------|------|-----|------------|-----|---------------|
| 6.3 | 7.7±0.3 | 6.6 | 6.6 | 2.7 | 0.5 to 0.8 | 2.0 | F80 |
| 8 | 8.7±0.3 | 8.4 | 8.4 | 3.0 | 0.5 to 0.8 | 3.1 | G90 |
| 8 | 10±0.5 | 8.4 | 8.4 | 3.0 | 0.7 to 1.1 | 3.1 | G10 |
| 10 | 8.7±0.3 | 10.4 | 10.4 | 3.3 | 0.7 to 1.1 | 4.7 | H90 |
| 10 | 10±0.5 | 10.4 | 10.4 | 3.3 | 0.7 to 1.1 | 4.7 | H10 |

() : Reference size

Series HTK

| φD | L | A | B | C | W | P | Casing symbol |
|----|--------|------|------|-----|------------|-----|---------------|
| 8 | 10±0.5 | 8.4 | 8.4 | 3.0 | 0.7 to 1.1 | 3.1 | G10 |
| 10 | 10±0.5 | 10.4 | 10.4 | 4.7 | 0.7 to 1.1 | 4.7 | H10 |

□ : Dummy terminal
() : Reference size

- Soldering conditions are described on page 13.
- Land pattern size are described on page 11.
- The taping specifications are described on page 14.

Coefficient of Frequency for Rated Ripple Current

| Frequency (Hz) | 120 | 1k | 10k | 100k or more |
|-------------------------------|------|------|------|--------------|
| Rated voltage (V) 25 to 63 | 0.10 | 0.30 | 0.60 | 1 |

Part numbering system

HVK (example : 35V270µF)

| | | | | | | | | | |
|-------------|---|----------------------|---|--------------------------|------------------------------|---------------|---|---|---------------|
| HVK | — | 35 | V | 271 | M | H10 | E | — | □ |
| Series code | | Rated voltage symbol | | Rated capacitance symbol | Capacitance tolerance symbol | Casing symbol | | | Taping symbol |

HTK (example : 35V270µF)

| | | | | | | | | | |
|-------------|---|----------------------|---|--------------------------|------------------------------|---------------|---|---|---------------|
| HTK | — | 35 | V | 271 | M | H10 | E | — | □ |
| Series code | | Rated voltage symbol | | Rated capacitance symbol | Capacitance tolerance symbol | Casing symbol | | | Taping symbol |

Standard Ratings

| Rated voltage (V) Rated capacitance (µF) | Item | 25 | | | 35 | | | 50 | | | 63 | | |
|---|---------|------------|-----------|----------------------|------------|-----------|----------------------|------------|-----------|----------------------|------------|-----------|----------------------|
| | | Case | ESR | Rated ripple current | Case | ESR | Rated ripple current | Case | ESR | Rated ripple current | Case | ESR | Rated ripple current |
| | | φ D×L (mm) | (mΩ max.) | (mA _{rms}) | φ D×L (mm) | (mΩ max.) | (mA _{rms}) | φ D×L (mm) | (mΩ max.) | (mA _{rms}) | φ D×L (mm) | (mΩ max.) | (mA _{rms}) |
| 22 | — | — | — | — | — | — | — | — | — | 6.3×7.7 | 80 | 900 | |
| 27 | — | — | — | — | — | — | — | — | — | 8×8.7 | 50 | 1000 | |
| 33 | — | — | — | — | — | — | 6.3×7.7 | 40 | 1100 | 8×10 | 40 | 1100 | |
| 47 | — | — | — | — | — | — | 8×8.7 | 35 | 1200 | 10×8.7 | 35 | 1200 | |
| 56 | — | — | — | — | — | — | — | — | — | 10×10 | 30 | 1400 | |
| 68 | — | — | — | 6.3×7.7 | 35 | 1400 | 8×10 | 30 | 1250 | — | — | — | |
| 82 | — | — | — | — | — | — | 10×8.7 | 28 | 1400 | — | — | — | |
| 100 | 6.3×7.7 | 30 | 1400 | 8×8.7 | 30 | 1500 | 10×10 | 28 | 1600 | — | — | — | |
| 150 | 8×8.7 | 27 | 1500 | 8×10 | 27 | 1600 | — | — | — | — | — | — | |
| 220 | 8×10 | 27 | 1600 | 10×8.7 | 25 | 1700 | — | — | — | — | — | — | |
| 270 | 10×8.7 | 25 | 1700 | 10×10 | 20 | 2000 | — | — | — | — | — | — | |
| 330 | 10×10 | 20 | 2000 | — | — | — | — | — | — | — | — | — | |

(Note) Rated ripple current : 125°C , 100Hz ; ESR. : 20°C , 100Hz

Chip Type GREEN CAP SMD Low ESR 105°C 2000hours Anti-cleaning solvent

- Super low E.S.R. and high ripple current are realized.
- Guaranteed 105°C, 2000 hours.

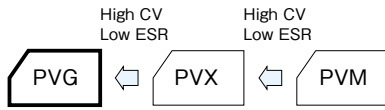

Marking color : Blue print

Specifications

| Item | Performance | |
|---|--|---|
| Category temperature range (°C) | -55 to +105 | |
| Tolerance at rated capacitance (%) | ±20 (20°C,120Hz) | |
| Leakage current (µA) *Note | Less than 0.2CV (after 2 minutes) C : Rated capacitance (µF) ; V : Rated voltage (V) (20°C) | |
| Tangent of the loss angle (tanδ) | Less than 0.12 (20°C,120Hz) | |
| Characteristics at high and low temperature | Impedance ratio (max.) Z-25°C / Z+20°C : 1.15 Z-55°C / Z+20°C : 1.25 (100kHz) | |
| Endurance (105°C) (Applied ripple current) | Test time | 2000 hours |
| | Leakage current | The initial specified value or less |
| | Percentage of capacitance change | Within ±20% of initial value |
| | Tangent of the loss angle | 150% or less of the initial specified value |
| | E.S.R. change | 150% or less of the initial specified value |
| Bias Humidity 60°C, 90 to 95%RH | Test time | 500 hours |
| | Leakage current | The initial specified value or less |
| | Percentage of capacitance change | Within ±20% of initial value |
| | Tangent of the loss angle | 150% or less of the initial specified value |
| | E.S.R. change | 150% or less of the initial specified value |
| Characteristics of applied surge voltage | The capacitors shall be subject to 1000 cycles each consisting of charge with the surge voltage specified at 105°C for 30 seconds through a protective resistor (Rc=1kΩ) in 6 minutes per cycle. Surge voltage : 1.15 times of rated voltage | |
| | Leakage current | The initial specified value or less |
| | Percentage of capacitance change | Within ±20% of initial value |
| | Tangent of the loss angle | 150% or less of the initial specified value |
| | E.S.R. change | 150% or less of the initial specified value |
| Failure rate | 0.5% per 1000 hours maximum (Confidence level 60% at 105°C) | |

*Note : If any doubt arises, measure the leakage current after following voltage application treatment.
Voltage application treatment : DC rated voltage are applied to the capacitors for 120 minutes at 105°C.

Outline Drawing

Unit : mm

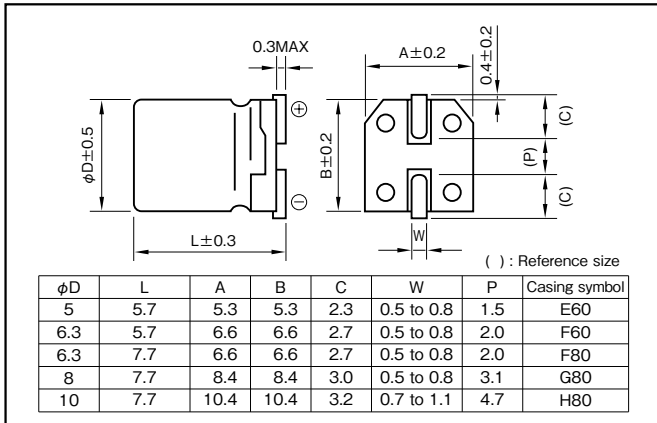

- Soldering conditions are described on page 13.
- Land pattern size are described on page 11.
- The taping specifications are described on page 14.

| Part numbering system (example : 4V151 M E60) | | | | | |
|---|----------------------|--------------------------|------------------------------|---------------|---------------|
| PVG | 4 | V | 151 | M | E60 |
| Series code | Rated voltage symbol | Rated capacitance symbol | Capacitance tolerance symbol | Casing symbol | Taping symbol |

Standard Ratings

| Rated voltage (V) Rated capacitance (µF) | Item | 2.5 | | | 4 | | | 6.3 | | |
|---|---------|-----------|-----------|----------------------|-----------|-----------|----------------------|-----------|-----------|----------------------|
| | | Case | ESR | Rated ripple current | Case | ESR | Rated ripple current | Case | ESR | Rated ripple current |
| | | φD×L (mm) | (mΩ max.) | (mA rms) | φD×L (mm) | (mΩ max.) | (mA rms) | φD×L (mm) | (mΩ max.) | (mA rms) |
| 120 | — | — | — | — | — | — | 5×5.7 | 8 | 4000 | |
| 150 | — | — | — | 5×5.7 | 8 | 4000 | — | — | — | |
| 220 | 5×5.7 | 8 | 4000 | 6.3×5.7 | 6 | 4500 | 6.3×5.7 | 7 | 4300 | |
| 270 | — | — | — | 6.3×5.7 | 6 | 4500 | 6.3×7.7 | 7 | 4600 | |
| 330 | 6.3×5.7 | 6 | 4500 | 6.3×7.7 | 6 | 4800 | 8×7.7 | 7 | 4700 | |
| 390 | 6.3×5.7 | 6 | 4500 | 6.3×7.7 | 6 | 4800 | — | — | — | |
| 470 | 6.3×7.7 | 6 | 4800 | 8×7.7 | 6 | 5000 | 8×7.7 | 7 | 4700 | |
| 560 | 6.3×7.7 | 6 | 4800 | — | — | — | 8×7.7 | 7 | 4700 | |
| 680 | — | — | — | 8×7.7 | 6 | 5000 | — | — | — | |
| 820 | — | — | — | — | — | — | 10×7.7 | 7 | 4900 | |
| 1000 | 8×7.7 | 6 | 5000 | 10×7.7 | 6 | 5200 | — | — | — | |
| 1200 | 10×7.7 | 6 | 5200 | — | — | — | — | — | — | |

(Note) Rated ripple current : 105°C, 100kHz ; E.S.R. : 20°C, 100kHz

POLYMER
HYBRID

Chip Type GREEN CAP SMD Low ESR 105°C 2000hours Anti-cleaning solvent

- Super low E.S.R. and high ripple current are realized.
- Guaranteed 105°C, 2000 hours.

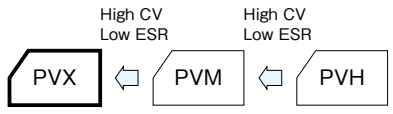

Marking color : Blue print

Specifications

| Item | Performance | |
|---|--|---|
| Category temperature range (°C) | -55 to +105 | |
| Tolerance at rated capacitance (%) | ±20 (20°C,120Hz) | |
| Leakage current (µA) *Note | Less than 0.2CV (after 2 minutes) C : Rated capacitance (µF) ; V : Rated voltage (V) (20°C) | |
| Tangent of the loss angle (tanδ) | Less than 0.12 (20°C,120Hz) | |
| Characteristics at high and low temperature | Impedance ratio (max.) Z-25°C / Z+20°C : 1.15 Z-55°C / Z+20°C : 1.25 (100kHz) | |
| Endurance (105°C) (Applied ripple current) | Test time | 2000 hours |
| | Leakage current | The initial specified value or less |
| | Percentage of capacitance change | Within ±20% of initial value |
| | Tangent of the loss angle | 150% or less of the initial specified value |
| | E.S.R. change | 150% or less of the initial specified value |
| Bias Humidity 60°C, 90 to 95%RH | Test time | 500 hours |
| | Leakage current | The initial specified value or less |
| | Percentage of capacitance change | Within ±20% of initial value |
| | Tangent of the loss angle | 150% or less of the initial specified value |
| | E.S.R. change | 150% or less of the initial specified value |
| Characteristics of applied surge voltage | The capacitors shall be subject to 1000 cycles each consisting of charge with the surge voltage specified at 105°C for 30 seconds through a protective resistor (Rc=1kΩ) in 6 minutes per cycle. Surge voltage : 1.15 times of rated voltage | |
| | Leakage current | The initial specified value or less |
| | Percentage of capacitance change | Within ±20% of initial value |
| | Tangent of the loss angle | 150% or less of the initial specified value |
| | E.S.R. change | 150% or less of the initial specified value |
| Failure rate | 0.5% per 1000 hours maximum (Confidence level 60% at 105°C) | |

*Note : If any doubt arises, measure the leakage current after following voltage application treatment.
Voltage application treatment : DC rated voltage are applied to the capacitors for 120 minutes at 105°C.

Outline Drawing

Unit : mm

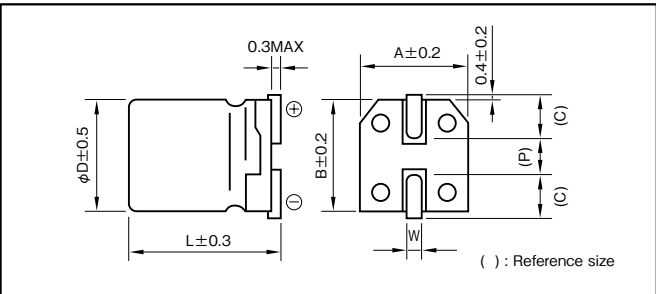

| φD | L | A | B | C | W | P | Casing symbol |
|-----|-----|------|------|-----|------------|-----|---------------|
| 5 | 5.7 | 5.3 | 5.3 | 2.3 | 0.5 to 0.8 | 1.5 | E60 |
| 6.3 | 5.7 | 6.6 | 6.6 | 2.7 | 0.5 to 0.8 | 2.0 | F60 |
| 8 | 6.7 | 8.4 | 8.4 | 3.0 | 0.5 to 0.8 | 3.1 | G70 |
| 10 | 7.7 | 10.4 | 10.4 | 3.2 | 0.7 to 1.1 | 4.7 | H80 |

- Soldering conditions are described on page 13.
- Land pattern size are described on page 11.
- The taping specifications are described on page 14.

Part numbering system (example : 4V151 M E60 E)

| | | | | | | | | | |
|-------------|---|----------------------|---|--------------------------|------------------------------|---------------|---|---|---------------|
| PVX | — | 4 | V | 151 | M | E60 | E | — | □ |
| Series code | | Rated voltage symbol | | Rated capacitance symbol | Capacitance tolerance symbol | Casing symbol | | | Taping symbol |

Standard Ratings

| Rated voltage (V) Rated capacitance (μF) | Item | 2.5 | | | 4 | | | 6.3 | | | 10 | | |
|---|---------|-----------|-----------|----------------------|-----------|-----------|----------------------|-----------|-----------|----------------------|-----------|-----------|----------------------|
| | | Case | ESR | Rated ripple current | Case | ESR | Rated ripple current | Case | ESR | Rated ripple current | Case | ESR | Rated ripple current |
| | | φD×L (mm) | (mΩ max.) | (mA _{rms}) | φD×L (mm) | (mΩ max.) | (mA _{rms}) | φD×L (mm) | (mΩ max.) | (mA _{rms}) | φD×L (mm) | (mΩ max.) | (mA _{rms}) |
| 100 | — | — | — | — | — | — | 5×5.7 | 15 | 3100 | 5×5.7 | 15 | 3100 | |
| 120 | — | — | — | — | — | — | — | — | — | 6.3×5.7 | 13 | 3300 | |
| 150 | 5×5.7 | 10 | 3800 | 5×5.7 | 10 | 3800 | 5×5.7 | 15 | 3100 | — | — | — | |
| 220 | 5×5.7 | 10 | 3800 | 5×5.7 | 10 | 3800 | 6.3×5.7 | 9 | 4000 | 8×6.7 | 10 | 3800 | |
| 270 | 5×5.7 | 10 | 3800 | — | — | — | — | — | — | — | — | — | |
| 330 | 6.3×5.7 | 9 | 4000 | 6.3×5.7 | 9 | 4000 | 8×6.7 | 8 | 4300 | 8×6.7 | 10 | 3800 | |
| 390 | 6.3×5.7 | 9 | 4000 | — | — | — | 8×6.7 | 8 | 4300 | — | — | — | |
| 470 | 8×6.7 | 8 | 4300 | 8×6.7 | 8 | 4300 | 8×6.7 | 8 | 4300 | 10×7.7 | 10 | 4000 | |
| 560 | 8×6.7 | 8 | 4300 | 8×6.7 | 8 | 4300 | — | — | — | — | — | — | |
| 680 | 8×6.7 | 8 | 4300 | 10×7.7 | 8 | 4600 | — | — | — | — | — | — | |
| 820 | — | — | — | — | — | — | 10×7.7 | 8 | 4600 | — | — | — | |
| 1000 | 10×7.7 | 8 | 4600 | 10×7.7 | 8 | 4600 | — | — | — | — | — | — | |
| 1200 | 10×7.7 | 8 | 4600 | — | — | — | — | — | — | — | — | — | |

(Note) Rated ripple current : 105°C, 100kHz ; E.S.R. : 20°C, 100kHz

POLYMER
HYBRID

Chip Type GREEN CAP SMD Low ESR 105°C 1000hours Anti-cleaning solvent

- 4.0mm height
- Super low E.S.R. and high ripple current are realized.
- Guaranteed 105°C, 1000 hours.

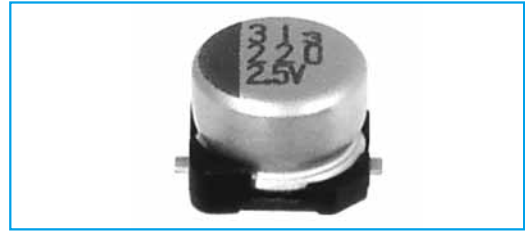

Marking color : Blue print

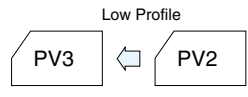

Specifications

| Item | Performance | | | |
|---|--|---|------|-------------------|
| Category temperature range (°C) | -55 to +105 | | | |
| Tolerance at rated capacitance (%) | ±20 (20°C,120Hz) | | | |
| Leakage current (μA) *Note | Less than 700μA (20°C) | | | |
| Tangent of the loss angle (tanδ) | Less than 0.12 (20°C,120Hz) | | | |
| Characteristics at high and low temperature | Impedance ratio (max.) | | | |
| | <table border="1"> <tr> <td>Z -25°C / Z +20°C</td> <td>1.15</td> </tr> <tr> <td>Z -55°C / Z +20°C</td> <td>1.25</td> </tr> </table> (100kHz) | Z -25°C / Z +20°C | 1.15 | Z -55°C / Z +20°C |
| Z -25°C / Z +20°C | 1.15 | | | |
| Z -55°C / Z +20°C | 1.25 | | | |
| Endurance (105°C) (Applied ripple current) | Test time | 1000 hours | | |
| | Leakage current | The initial specified value or less | | |
| | Percentage of capacitance change | Within ±20% of initial value | | |
| | Tangent of the loss angle | 150% or less of the initial specified value | | |
| | E.S.R. change | 150% or less of the initial specified value | | |
| Bias Humidity 60°C, 90 to 95%RH | Test time | 500 hours | | |
| | Leakage current | The initial specified value or less | | |
| | Percentage of capacitance change | Within ±20% of initial value | | |
| | Tangent of the loss angle | 150% or less of the initial specified value | | |
| | E.S.R. change | 150% or less of the initial specified value | | |
| Characteristics of applied surge voltage | The capacitors shall be subject to 1000 cycles each consisting of charge with the surge voltage specified at 105°C for 30 seconds through a protective resistor (Rc=1kΩ) in 6 minutes per cycle. Surge voltage : 1.15 times of rated voltage | | | |
| | Leakage current | The initial specified value or less | | |
| | Percentage of capacitance change | Within ±20% of initial value | | |
| | Tangent of the loss angle | 150% or less of the initial specified value | | |
| | E.S.R. change | 150% or less of the initial specified value | | |
| Failure tare | 0.5% per 1000 hours maximum (Confidence level 60% at 105°C) | | | |

*Note : If any doubt arises, measure the leakage current after following voltage application treatment.
Voltage application treatment : DC rated voltage are applied to the capacitors for 120 minutes at 105°C.

Outline Drawing

Unit : mm

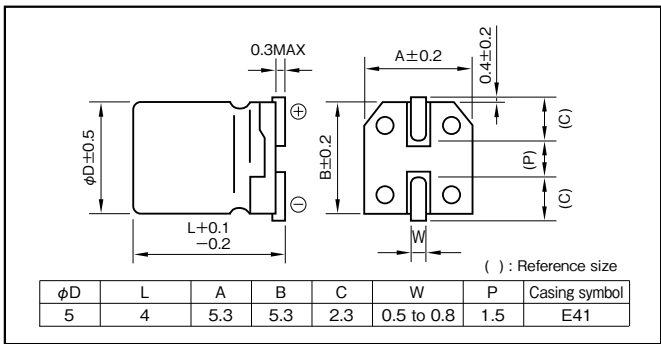

- Soldering conditions are described on page 13.
- Land pattern size are described on page 11.
- The taping specifications are described on page 14.

Part numbering system (example : 2.5V220μF)

| | | | | | | | | |
|-------------|---|----------------------|---|--------------------------|------------------------------|---------------|---|---------------|
| PV3 | — | 2R5 | V | 221 | M | E41 | — | |
| Series code | | Rated voltage symbol | | Rated capacitance symbol | Capacitance tolerance symbol | Casing symbol | | Taping symbol |

Standard Ratings

| Rated voltage (V) Rated capacitance (µF) | Item | 2.5 | | | 6.3 | | |
|---|--------------|-----------|----------|----------------------|-----------|----------|----------------------|
| | | Case | ESR | Rated ripple current | Case | ESR | Rated ripple current |
| | φ D × L (mm) | (mΩ max.) | (mA rms) | φ D × L (mm) | (mΩ max.) | (mA rms) | |
| 150 | — | — | — | 5 × 4.0 | 25 | 2700 | |
| 220 | 5 × 4.0 | 25 | 3300 | — | — | — | |

(Note) Rated ripple current : 105°C , 100Hz ; ESR. : 20°C , 100Hz

| | | | | | |
|------------------|-----------|-----|---------|--------------------|-----------------------|
| Chip Type | GREEN CAP | SMD | Low ESR | 105°C 2000hours | Anti-cleaning solvent |
|------------------|-----------|-----|---------|--------------------|-----------------------|

- 4.5mm height
- Super low E.S.R. and high ripple current are realized.
- Guaranteed 105°C, 2000 hours.

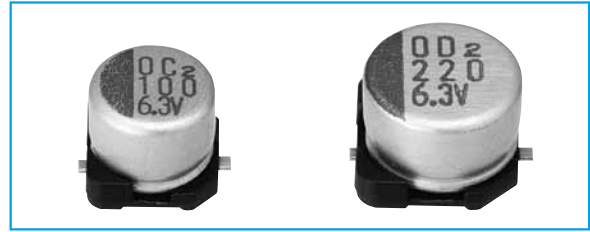
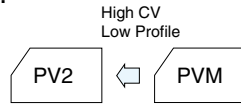

Marking color : Blue print

Specifications

| Item | Performance | |
|---|--|--|
| Category temperature range (°C) | -55 to +105 | |
| Tolerance at rated capacitance (%) | ±20 (20°C,120Hz) | |
| Leakage current (µA) *Note | Rated voltage (V) 2.5 to 20 25 | |
| | Leakage current (µA) Less than 0.2 CV (after 2 minutes) Less than 0.5 CV (after 2 minutes) | |
| C : Rated capacitance (µF) ; V : Rated voltage (V) (20°C) | | |
| Tangent of the loss angle (tanδ) | Less than 0.12 (20°C,120Hz) | |
| Characteristics at high and low temperature | Impedance ratio (max.) | |
| | Z-25°C/Z+20°C : 1.15 Z-55°C/Z+20°C : 1.25 (100kHz) | |
| Endurance (105°C) (Applied ripple current) | Test time 2000 hours | |
| | Leakage current The initial specified value or less | |
| | Percentage of capacitance change Within ±20% of initial value | |
| | Tangent of the loss angle 150% or less of the initial specified value | |
| | E.S.R. change 150% or less of the initial specified value | |
| Bias Humidity 60°C, 90 to 95%RH | Test time 500 hours | |
| | Leakage current The initial specified value or less | |
| | Percentage of capacitance change Within ±20% of initial value | |
| | Tangent of the loss angle 150% or less of the initial specified value | |
| | E.S.R. change 150% or less of the initial specified value | |
| Characteristics of applied surge voltage | The capacitors shall be subject to 1000 cycles each consisting of charge with the surge voltage specified at 105°C for 30 seconds through a protective resistor (Rc=1kΩ) in 6 minutes per cycle. Surge voltage : 1.15 times of rated voltage | |
| | Leakage current The initial specified value or less | |
| | Percentage of capacitance change Within ±20% of initial value | |
| | Tangent of the loss angle 150% or less of the initial specified value | |
| | E.S.R. change 150% or less of the initial specified value | |
| Failure rate | 0.5% per 1000 hours maximum (Confidence level 60% at 105°C) | |

*Note : If any doubt arises, measure the leakage current after following voltage application treatment.
Voltage application treatment : DC rated voltage are applied to the capacitors for 120 minutes at 105°C.

Outline Drawing

Unit : mm

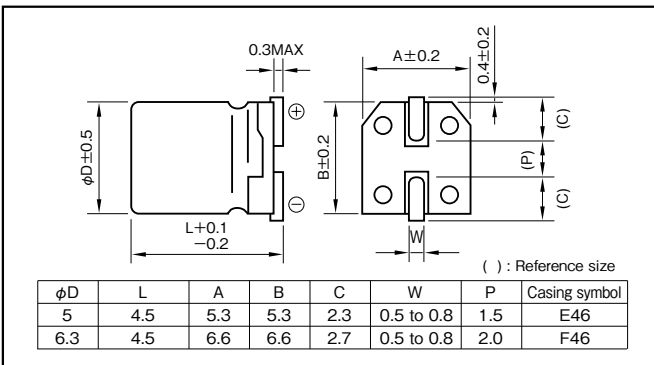

- Soldering conditions are described on page 13.
- Land pattern size are described on page 11.
- The taping specifications are described on page 14.

| Part numbering system (example : 4V120µF) | | | | | | | |
|---|---|----------------------|---|--------------------------|------------------------------|---------------|---------------|
| PV2 | — | 4 | V | 121 | M E46 — □ | | |
| Series code | | Rated voltage symbol | | Rated capacitance symbol | Capacitance tolerance symbol | Casing symbol | Taping symbol |

Standard Ratings

| Rated voltage (V) Item | 2.5 | | | 4 | | | 6.3 | | | 10 | | | 16 | | |
|---------------------------|-------------------------------------|-----------|----------------------|-----------|-----------|----------------------|-----------|-----------|----------------------|-----------|-----------|----------------------|-----------|-----------|----------------------|
| | Case | ESR | Rated ripple current | Case | ESR | Rated ripple current | Case | ESR | Rated ripple current | Case | ESR | Rated ripple current | Case | ESR | Rated ripple current |
| | Rated capacitance (μF) φD×L (mm) | (mΩ max.) | (mA rms) | φD×L (mm) | (mΩ max.) | (mA rms) | φD×L (mm) | (mΩ max.) | (mA rms) | φD×L (mm) | (mΩ max.) | (mA rms) | φD×L (mm) | (mΩ max.) | (mA rms) |
| 39 | — | — | — | — | — | — | — | — | — | — | — | — | 6.3×4.5 | 40 | 1450 |
| 100 | — | — | — | — | — | — | 5×4.5 | 20 | 1300 | — | — | — | — | — | — |
| 120 | — | — | — | 5×4.5 | 20 | 1400 | — | — | — | 6.3×4.5 | 30 | 1750 | — | — | — |
| 150 | — | — | — | — | — | — | 6.3×4.5 | 16 | 1950 | — | — | — | — | — | — |
| 180 | 5×4.5 | 20 | 1400 | — | — | — | — | — | — | — | — | — | — | — | — |
| 220 | — | — | — | 6.3×4.5 | 16 | 2400 | 6.3×4.5 | 16 | 1950 | — | — | — | — | — | — |
| 270 | 6.3×4.5 | 16 | 2400 | — | — | — | — | — | — | — | — | — | — | — | — |
| 330 | 6.3×4.5 | 13 | 2400 | — | — | — | — | — | — | — | — | — | — | — | — |
| 390 | 6.3×4.5 | 16 | 2400 | — | — | — | — | — | — | — | — | — | — | — | — |

| Rated voltage (V) Item | 20 | | | 25 | | |
|---------------------------|-------------------------------------|-----------|----------------------|-----------|-----------|----------------------|
| | Case | ESR | Rated ripple current | Case | ESR | Rated ripple current |
| | Rated capacitance (μF) φD×L (mm) | (mΩ max.) | (mA rms) | φD×L (mm) | (mΩ max.) | (mA rms) |
| 15 | — | — | — | 6.3×4.5 | 45 | 1150 |
| 22 | 6.3×4.5 | 45 | 1250 | — | — | — |

(Note) Rated ripple current : 105°C, 100kHz ; E.S.R. : 20°C, 100kHz

Chip Type GREEN CAP SMD Low ESR 105°C 2000hours Anti-cleaning solvent

- Super low E.S.R. and high ripple current are realized.
- Guaranteed 105°C, 2000 hours.

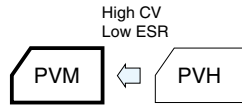

Marking color : Blue print

Specifications

| Item | Performance | |
|---|--|---|
| Category temperature range (°C) | -55 to +105 | |
| Tolerance at rated capacitance (%) | ±20 (20°C, 120Hz) | |
| Leakage current (µA) *Note | Rated voltage (V) | 2.5 to 20 25.35 |
| | Leakage current (µA) | Less than 0.2 CV (after 2 minutes) Less than 0.5 CV (after 2 minutes) |
| C : Rated capacitance (µF) ; V : Rated voltage (V) (20°C) | | |
| Tangent of the loss angle (tanδ) | Less than 0.12 (20°C, 120Hz) | |
| Characteristics at high and low temperature | Impedance ratio (max.) | |
| | Z-25°C/Z+20°C : 1.15 Z-55°C/Z+20°C : 1.25 (100kHz) | |
| Endurance (105°C) (Applied ripple current) | Test time | 2000 hours |
| | Leakage current | The initial specified value or less |
| | Percentage of capacitance change | Within ±20% of initial value |
| | Tangent of the loss angle | 150% or less of the initial specified value |
| | E.S.R. change | 150% or less of the initial specified value |
| Bias Humidity 60°C, 90 to 95%RH | Test time | 500 hours |
| | Leakage current | The initial specified value or less |
| | Percentage of capacitance change | Within ±20% of initial value |
| | Tangent of the loss angle | 150% or less of the initial specified value |
| | E.S.R. change | 150% or less of the initial specified value |
| Characteristics of applied surge voltage | The capacitors shall be subject to 1000 cycles each consisting of charge with the surge voltage specified at 105°C for 30 seconds through a protective resistor (Rc=1kΩ) in 6 minutes per cycle. Surge voltage : 1.15 times of rated voltage | |
| | Leakage current | The initial specified value or less |
| | Percentage of capacitance change | Within ±20% of initial value |
| | Tangent of the loss angle | 150% or less of the initial specified value |
| | E.S.R. change | 150% or less of the initial specified value |
| Failure rate | 0.5% per 1000 hours maximum (Confidence level 60% at 105°C) | |

*Note : If any doubt arises, measure the leakage current after following voltage application treatment.
Voltage application treatment : DC rated voltage are applied to the capacitors for 120 minutes at 105°C.

Outline Drawing

Unit : mm

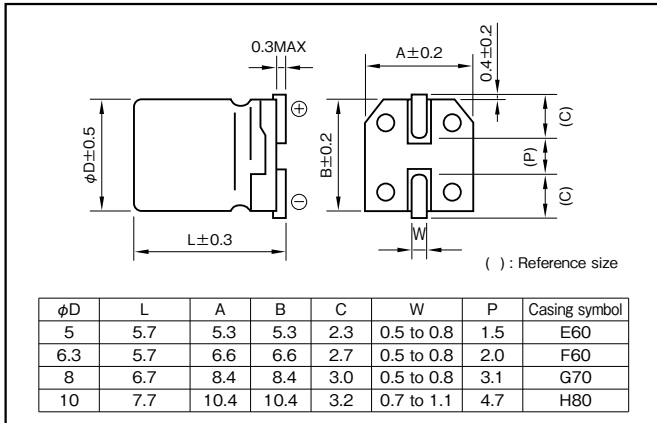

- Soldering conditions are described on page 13.
- Land pattern size are described on page 11.
- The taping specifications are described on page 14.

Part numbering system (example : 4V151M E60 E)

| | | | | | | | |
|-------------|----------------------|--------------------------|------------------------------|---------------|-----|---|---------------|
| PVM | 4 | V | 151 | M | E60 | E | |
| Series code | Rated voltage symbol | Rated capacitance symbol | Capacitance tolerance symbol | Casing symbol | | | Taping symbol |

Standard Ratings

| Rated capacitance (μF) | 2.5 | | | 4 | | | 6.3 | | | 10 | | | 16 | | |
|------------------------|-----------|-----------|----------------------|-----------|-----------|----------------------|-----------|-----------|----------------------|-----------|-----------|----------------------|-----------|-----------|----------------------|
| | Item | | | Item | | | Item | | | Item | | | Item | | |
| | Case | ESR | Rated ripple current | Case | ESR | Rated ripple current | Case | ESR | Rated ripple current | Case | ESR | Rated ripple current | Case | ESR | Rated ripple current |
| | φD×L (mm) | (mΩ max.) | (mArms) | φD×L (mm) | (mΩ max.) | (mArms) | φD×L (mm) | (mΩ max.) | (mArms) | φD×L (mm) | (mΩ max.) | (mArms) | φD×L (mm) | (mΩ max.) | (mArms) |
| 33 | — | — | — | — | — | — | — | — | — | — | — | — | 5×5.7 | 35 | 2070 |
| 39 | — | — | — | — | — | — | — | — | — | — | — | — | 5×5.7 | 35 | 2070 |
| 47 | — | — | — | — | — | — | — | — | — | 5×5.7 | 28 | 2310 | 6.3×5.7 | 28 | 2340 |
| 56 | — | — | — | — | — | — | — | — | — | 5×5.7 | 28 | 2310 | — | — | — |
| 68 | — | — | — | — | — | — | — | — | — | 5×5.7 | 28 | 2310 | 6.3×5.7 | 28 | 2340 |
| 100 | — | — | — | 5×5.7 | 22 | 2610 | 5×5.7 | 24 | 2500 | 6.3×5.7 | 25 | 2530 | 8×6.7 | 24 | 3010 |
| 120 | — | — | — | — | — | — | 5×5.7 | 24 | 2500 | 6.3×5.7 | 25 | 2530 | 8×6.7 | 24 | 3010 |
| 150 | — | — | — | 5×5.7 | 22 | 2610 | — | — | — | — | — | — | — | — | — |
| 180 | 5×5.7 | 21 | 2670 | — | — | — | — | — | — | — | — | — | — | — | — |
| 220 | 5×5.7 | 21 | 2670 | 5×5.7 | 22 | 2610 | 6.3×5.7 | 15 | 3160 | 8×6.7 | 21 | 3220 | 10×7.7 | 22 | 3450 |
| 270 | — | — | — | 6.3×5.7 | 15 | 3160 | — | — | — | 8×6.7 | 21 | 3220 | — | — | — |
| 330 | 6.3×5.7 | 15 | 3160 | 6.3×5.7 | 15 | 3160 | 8×6.7 | 14 | 3950 | 10×7.7 | 19 | 3800 | — | — | — |
| 390 | 6.3×5.7 | 15 | 3160 | — | — | — | 8×6.7 | 14 | 3950 | — | — | — | — | — | — |
| 470 | 8×6.7 | 13 | 3600 | 8×6.7 | 14 | 3950 | 8×6.7 | 14 | 3950 | 10×7.7 | 19 | 3800 | — | — | — |
| 560 | 8×6.7 | 13 | 3600 | 8×6.7 | 14 | 3950 | — | — | — | — | — | — | — | — | — |
| 680 | 8×6.7 | 13 | 3600 | — | — | — | — | — | — | — | — | — | — | — | — |
| 820 | — | — | — | — | — | — | 10×7.7 | 14 | 4300 | — | — | — | — | — | — |
| 1000 | 10×7.7 | 13 | 4450 | 10×7.7 | 14 | 4300 | — | — | — | — | — | — | — | — | — |
| 1200 | 10×7.7 | 13 | 4450 | — | — | — | — | — | — | — | — | — | — | — | — |

POLYMER HYBRID

| Rated capacitance (μF) | 20 | | | 25 | | | 35 | | |
|------------------------|-----------|-----------|----------------------|-----------|-----------|----------------------|-----------|-----------|----------------------|
| | Item | | | Item | | | Item | | |
| | Case | ESR | Rated ripple current | Case | ESR | Rated ripple current | Case | ESR | Rated ripple current |
| | φD×L (mm) | (mΩ max.) | (mArms) | φD×L (mm) | (mΩ max.) | (mArms) | φD×L (mm) | (mΩ max.) | (mArms) |
| 10 | — | — | — | 6.3×5.7 | 60 | 1500 | — | — | — |
| 15 | — | — | — | — | — | — | 8×6.7 | 150 | 1000 |
| 22 | 6.3×5.7 | 50 | 1650 | 8×6.7 | 50 | 1800 | — | — | — |
| 33 | — | — | — | — | — | — | 10×7.7 | 100 | 1800 |
| 39 | — | — | — | 10×7.7 | 45 | 2100 | — | — | — |
| 47 | 8×6.7 | 45 | 2000 | — | — | — | — | — | — |
| 82 | 10×7.7 | 40 | 2500 | — | — | — | — | — | — |

(Note) Rated ripple current : 105°C, 100kHz ; E.S.R. : 20°C, 100kHz

Chip Type GREEN CAP SMD Low ESR 125°C 1000hours Anti-cleaning solvent

- Super low E.S.R. and high ripple current are realized.
- Guaranteed 125°C, 1000 hours.



Marking color : Blue print

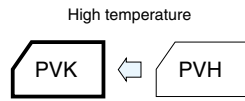

Specifications

| Item | Performance | |
|---|--|---|
| Category temperature range (°C) | -55 to +125 | |
| Tolerance at rated capacitance (%) | ±20 (20°C,120Hz) | |
| Leakage current (μA) *Note C : Rated capacitance (μF) ; V : Rated voltage (V) | Rated voltage (V) | 2.5 to 20 25,35 |
| | Leakage current (μA) | Less than 0.2 CV (after 2 minutes) Less than 0.5 CV (after 2 minutes) |
| Tangent of the loss angle (tanδ) | Less than 0.12 (20°C,120Hz) | |
| Characteristics at high and low temperature | Impedance ratio (max.) Z-25°C/Z+20°C : 1.15 Z-55°C/Z+20°C : 1.25 (100kHz) | |
| Endurance (125°C) (Applied ripple current) | Test time | 1000 hours |
| | Leakage current | The initial specified value or less |
| | Percentage of capacitance change | Within ±20% of initial value |
| | Tangent of the loss angle | 150% or less of the initial specified value |
| | E.S.R. change | 150% or less of the initial specified value |
| Bias Humidity 60°C, 90 to 95%RH | Test time | 500 hours |
| | Leakage current | The initial specified value or less |
| | Percentage of capacitance change | Within ±20% of initial value |
| | Tangent of the loss angle | 150% or less of the initial specified value |
| | E.S.R. change | 150% or less of the initial specified value |
| Characteristics of applied surge voltage | The capacitors shall be subject to 1000 cycles each consisting of charge with the surge voltage specified at 125°C for 30 seconds through a protective resistor (Rc=1kΩ) in 6 minutes per cycle. Surge voltage : 1.15 times of rated voltage | |
| | Leakage current | The initial specified value or less |
| | Percentage of capacitance change | Within ±20% of initial value |
| | Tangent of the loss angle | 150% or less of the initial specified value |
| | E.S.R. change | 150% or less of the initial specified value |
| Failure rate | 0.5% per 1000 hours maximum (Confidence level 60% at 125°C) | |

*Note : If any doubt arises, measure the leakage current after following voltage application treatment.
Voltage application treatment : DC rated voltage are applied to the capacitors for 120 minutes at 125°C.

Outline Drawing

Unit : mm

| φD | L | A | B | C | W | P | Casing symbol |
|-----|-----|------|------|-----|------------|-----|---------------|
| 6.3 | 5.7 | 6.6 | 6.6 | 2.7 | 0.5 to 0.8 | 2.0 | F60 |
| 8 | 6.7 | 8.4 | 8.4 | 3.0 | 0.5 to 0.8 | 3.1 | G70 |
| 10 | 7.7 | 10.4 | 10.4 | 3.2 | 0.7 to 1.1 | 4.7 | H80 |

- Soldering conditions are described on page 13.
- Land pattern size are described on page 11.
- The taping specifications are described on page 14.

Part numbering system (example : 4V151 M F60 E □)

| | | | | | | | |
|-------------|----------------------|--------------------------|------------------------------|---------------|---------------|---|---|
| PVK | 4 | V | 151 | M | F60 | E | □ |
| Series code | Rated voltage symbol | Rated capacitance symbol | Capacitance tolerance symbol | Casing symbol | Taping symbol | | |

Standard Ratings

| Rated voltage (V) | Item | 2.5 | | | 4 | | | 6.3 | | | 10 | | | 16 | | |
|-------------------|---------|-----------|-----------|----------------------|-----------|-----------|----------------------|-----------|-----------|----------------------|-----------|-----------|----------------------|-----------|-----------|----------------------|
| | | Case | ESR | Rated ripple current | Case | ESR | Rated ripple current | Case | ESR | Rated ripple current | Case | ESR | Rated ripple current | Case | ESR | Rated ripple current |
| | | φD×L (mm) | (mΩ max.) | (mA _{rms}) | φD×L (mm) | (mΩ max.) | (mA _{rms}) | φD×L (mm) | (mΩ max.) | (mA _{rms}) | φD×L (mm) | (mΩ max.) | (mA _{rms}) | φD×L (mm) | (mΩ max.) | (mA _{rms}) |
| 33 | — | — | — | — | — | — | — | — | — | — | — | — | 6.3×5.7 | 37 | 590 | |
| 39 | — | — | — | — | — | — | — | — | — | — | — | — | 6.3×5.7 | 37 | 590 | |
| 47 | — | — | — | — | — | — | — | — | — | — | 6.3×5.7 | 31 | 680 | 6.3×5.7 | 37 | 590 |
| 56 | — | — | — | — | — | — | — | — | — | — | 6.3×5.7 | 31 | 680 | — | — | — |
| 68 | — | — | — | — | — | — | — | 6.3×5.7 | 27 | 720 | — | — | — | — | — | — |
| 82 | — | — | — | — | — | — | — | 6.3×5.7 | 27 | 720 | — | — | — | 8×6.7 | 30 | 830 |
| 100 | — | — | — | 6.3×5.7 | 26 | 770 | 6.3×5.7 | 27 | 720 | 8×6.7 | 27 | 880 | 8×6.7 | 30 | 830 | |
| 120 | — | — | — | — | — | — | 6.3×5.7 | 27 | 720 | 8×6.7 | 27 | 880 | — | — | — | |
| 150 | — | — | — | 6.3×5.7 | 26 | 770 | 8×6.7 | 25 | 960 | 8×6.7 | 27 | 880 | 10×7.7 | 26 | 930 | |
| 180 | — | — | — | — | — | — | — | — | — | — | — | — | 10×7.7 | 26 | 930 | |
| 220 | 6.3×5.7 | 25 | 770 | 8×6.7 | 25 | 960 | 8×6.7 | 25 | 960 | 10×7.7 | 24 | 1010 | — | — | — | |
| 270 | — | — | — | — | — | — | — | — | — | 10×7.7 | 24 | 1010 | — | — | — | |
| 330 | 8×6.7 | 23 | 960 | 8×6.7 | 25 | 960 | 10×7.7 | 20 | 1100 | 10×7.7 | 24 | 1010 | — | — | — | |
| 470 | 8×6.7 | 23 | 960 | 10×7.7 | 20 | 1100 | 10×7.7 | 20 | 1100 | — | — | — | — | — | — | |
| 560 | 8×6.7 | 23 | 960 | — | — | — | — | — | — | — | — | — | — | — | — | |
| 680 | — | — | — | 10×7.7 | 20 | 1100 | — | — | — | — | — | — | — | — | — | |
| 1000 | 10×7.7 | 19 | 1100 | — | — | — | — | — | — | — | — | — | — | — | — | |

POLYMER
HYBRID

| Rated voltage (V) | Item | 20 | | | 25 | | |
|-------------------|---------|-----------|-----------|----------------------|-----------|-----------|----------------------|
| | | Case | ESR | Rated ripple current | Case | ESR | Rated ripple current |
| | | φD×L (mm) | (mΩ max.) | (mA _{rms}) | φD×L (mm) | (mΩ max.) | (mA _{rms}) |
| 10 | — | — | — | 6.3×5.7 | 65 | 500 | |
| 22 | 6.3×5.7 | 50 | 590 | 8×6.7 | 50 | 600 | |
| 39 | 8×6.7 | 45 | 780 | 10×7.7 | 45 | 700 | |
| 47 | 8×6.7 | 45 | 780 | — | — | — | |
| 82 | 10×7.7 | 40 | 820 | — | — | — | |

(Note) Rated ripple current : 125°C, 100kHz ; ESR : 20°C, 100kHz

Chip Type GREEN CAP SMD Low ESR 105°C 2000hours Anti-cleaning solvent

- High voltage (to 63V)
- High CV and low E.S.R and High ripple Current are realized
- Guaranteed 105°C, 2000 hours.

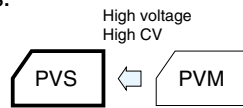

Marking color : Blue print

Specifications

| Item | Performance | |
|---|--|---|
| Category temperature range (°C) | -55 to +105 | |
| Tolerance at rated capacitance (%) | ±20 (20°C,120Hz) | |
| Leakage current (μA) *Note | Rated voltage (V) 35 to 63 | |
| | Leakage current (μA) Less than 0.5 CV (after 2 minutes) | |
| C : Rated capacitance (μF) ; V : Rated voltage (V) (20°C) | | |
| Tangent of the loss angle (tanδ) | Less than 0.12 (20°C,120Hz) | |
| Characteristics at high and low temperature | Impedance ratio (max.) | |
| | Z-25°C/Z+20°C : 1.15 Z-55°C/Z+20°C : 1.25 (100kHz) | |
| Endurance (105°C) (Applied ripple current) | Test time 2000 hours | |
| | Leakage current The initial specified value or less | |
| | Percentage of capacitance change Within ±20% of initial value | |
| | Tangent of the loss angle 150% or less of the initial specified value | |
| | E.S.R. change 150% or less of the initial specified value | |
| Bias Humidity 60°C, 90 to 95%RH | Test time 500 hours | |
| | Leakage current The initial specified value or less | |
| | Percentage of capacitance change Within ±20% of initial value | |
| | Tangent of the loss angle 150% or less of the initial specified value | |
| | E.S.R. change 150% or less of the initial specified value | |
| Characteristics of applied surge voltage | The capacitors shall be subject to 1000 cycles each consisting of charge with the surge voltage specified at 105°C for 30 seconds through a protective resistor (Rc=1kΩ) in 6 minutes per cycle. Surge voltage : 1.15 times of rated voltage | |
| | Leakage current | The initial specified value or less |
| | Percentage of capacitance change | Within ±20% of initial value |
| | Tangent of the loss angle | 150% or less of the initial specified value |
| | E.S.R. change | 150% or less of the initial specified value |
| Failure rate | 0.5% per 1000 hours maximum (Confidence level 60% at 105°C) | |

*Note : If any doubt arises, measure the leakage current after following voltage application treatment.
Voltage application treatment : DC rated voltage are applied to the capacitors for 120 minutes at 105°C.

Outline Drawing

Unit : mm

| φD | L | A | B | C | W | P | Casing symbol |
|-----|-----|------|------|-----|------------|-----|---------------|
| 6.3 | 5.7 | 6.6 | 6.6 | 2.7 | 0.5 to 0.8 | 2.0 | F60 |
| 8 | 6.7 | 8.4 | 8.4 | 3.0 | 0.5 to 0.8 | 3.1 | G70 |
| 10 | 7.7 | 10.4 | 10.4 | 3.2 | 0.7 to 1.1 | 4.7 | H80 |

- Soldering conditions are described on page 13.
- Land pattern size are described on page 11.
- The taping specifications are described on page 14.

| Part numbering system (example : 35V100μF) | | | | | |
|--|----------------------|---|--------------------------|------------------------------|---------------|
| PVS | 35 | V | 101 | M | H80 |
| Series code | Rated voltage symbol | | Rated capacitance symbol | Capacitance tolerance symbol | Casing symbol |
| | | | | | Taping symbol |

Standard Ratings

| Rated voltage (V) Rated capacitance (μF) | Item | 35 | | | 50 | | | 63 | | |
|---|---------|-----------|-----------|----------------------|-----------|-----------|----------------------|-----------|-----------|----------------------|
| | | Case | ESR | Rated ripple current | Case | ESR | Rated ripple current | Case | ESR | Rated ripple current |
| | | φD×L (mm) | (mΩ max.) | (mA _{rms}) | φD×L (mm) | (mΩ max.) | (mA _{rms}) | φD×L (mm) | (mΩ max.) | (mA _{rms}) |
| 18 | — | — | — | — | — | — | 8×6.7 | 55 | 2300 | |
| 22 | — | — | — | — | — | — | — | — | — | |
| 27 | 6.3×5.7 | 40 | 2600 | 8×6.7 | 45 | 2600 | — | — | — | |
| 33 | — | — | — | — | — | — | — | — | — | |
| 39 | — | — | — | — | — | — | 10×7.7 | 50 | 3000 | |
| 47 | 8×6.7 | 35 | 2800 | — | — | — | — | — | — | |
| 56 | — | — | — | 10×7.7 | 40 | 3200 | — | — | — | |
| 68 | — | — | — | — | — | — | — | — | — | |
| 82 | — | — | — | — | — | — | — | — | — | |
| 100 | 10×7.7 | 30 | 3500 | — | — | — | — | — | — | |

(Note) Rated ripple current : 105°C, 100kHz ; ESR. : 20°C, 100kHz

Radial lead Type

- GREEN CAP
- Low ESR
- 105°C
2000hours
- Anti-cleaning solvent

- Low E.S.R. and high ripple current are realized.
- Guaranteed 105°C, 2000 hours.

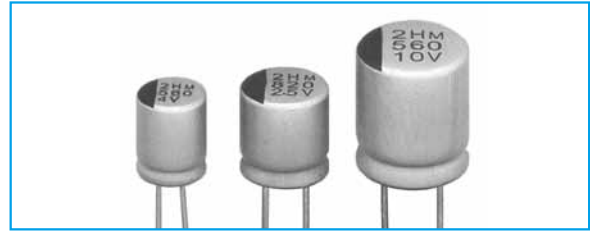

Marking color : Red print

Specifications

| Item | Performance | |
|--|--|---|
| Category temperature range (°C) | -55 to +105 | |
| Tolerance at rated capacitance (%) | ±20 (20°C,120Hz) | |
| Leakage current (μA) *Note | Less than 0.2CV or 500 whichever is larger (after 2 minutes) C : Rated capacitance (μF) ; V : Rated voltage (V) (20°C) | |
| Tangent of the loss angle (tanδ) | Less than 0.12 (20°C,120Hz) | |
| Characteristics at high and low temperature | Impedance ratio (max.) Z-55°C / Z+20°C : 1.50 (100kHz) | |
| Endurance (105°C) (Applied ripple current) | Test time | 2000 hours |
| | Leakage current | The initial specified value or less |
| | Percentage of capacitance change | Within ±20% of initial value |
| | Tangent of the loss angle | 150% or less of the initial specified value |
| | E.S.R. change | 200% or less of the initial specified value |
| Damp heat, steady state (humidity) 60°C, 90 to 95%RH | Test time | 500 hours |
| | Leakage current | The initial specified value or less |
| | Percentage of capacitance change | Within ±20% of initial value |
| | Tangent of the loss angle | 150% or less of the initial specified value |
| | E.S.R. change | 200% or less of the initial specified value |
| Characteristics of applied surge voltage | The capacitors shall be subject to 1000 cycles each consisting of charge with the surge voltage specified at 105°C for 30 seconds through a protective resistor (Rc=1kΩ) in 6 minutes per cycle. Surge voltage : 1.15 times of rated voltage | |
| | Leakage current | The initial specified value or less |
| | Percentage of capacitance change | Within ±20% of initial value |
| | Tangent of the loss angle | 150% or less of the initial specified value |
| | E.S.R. change | 200% or less of the initial specified value |
| Failure rate | 0.5% per 1000 hours maximum (Confidence level 60% at 105°C) | |

*Note : If any doubt arises, measure the leakage current after following voltage application treatment.
Voltage application treatment : DC rated voltage are applied to the capacitors for 120 minutes at 105°C.

Outline Drawing

Unit : mm

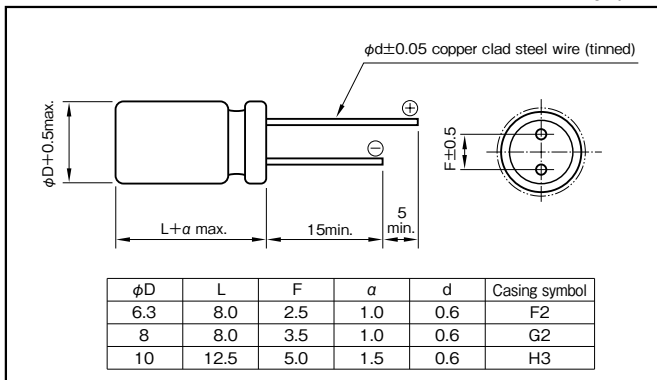

- Soldering conditions are described on page 12.
- The taping specifications are described on page 17,18.

| Part numbering system (example : 4V561 M F2 B) | | | | | | |
|--|---|----------------------|---|--------------------------|------------------------------|---------------|
| PRM | — | 4 | V | 561 | M | F2 B |
| Series code | | Rated voltage symbol | | Rated capacitance symbol | Capacitance tolerance symbol | Casing symbol |
| | | | | | Optional symbol | Taping symbol |

Standard Ratings

| Rated voltage (V) | Item | 2.5 | | | | 4 | | | | 6.3 | | | | 10 | | | |
|-------------------|---------|----------|-------|-----------|----------------------|----------|-------|-----------|----------------------|----------|-------|-----------|----------------------|----------|-------|-----------|----------------------|
| | | Case | tan δ | ESR | Rated ripple current | Case | tan δ | ESR | Rated ripple current | Case | tan δ | ESR | Rated ripple current | Case | tan δ | ESR | Rated ripple current |
| | | φD×L(mm) | | (mΩ max.) | (mA rms) | φD×L(mm) | | (mΩ max.) | (mA rms) | φD×L(mm) | | (mΩ max.) | (mA rms) | φD×L(mm) | | (mΩ max.) | (mA rms) |
| 220 | — | — | — | — | — | — | — | — | — | — | — | — | — | 6.3×8.0 | 0.10 | 10 | 4680 |
| 270 | — | — | — | — | — | — | — | — | — | — | — | — | — | 6.3×8.0 | 0.10 | 10 | 4680 |
| 330 | 6.3×8.0 | 0.10 | 7 | 5600 | — | — | — | — | 6.3×8.0 | 0.10 | 10 | 4680 | 8×8.0 | 0.08 | 10 | 5000 | |
| 390 | — | — | — | — | — | — | — | — | — | — | — | — | — | 8×8.0 | 0.08 | 10 | 5000 |
| 470 | 6.3×8.0 | 0.10 | 7 | 5600 | — | — | — | — | 6.3×8.0 | 0.10 | 7 | 5600 | 8×8.0 | 0.08 | 8 | 5700 | |
| 560 | 6.3×8.0 | 0.10 | 7 | 5600 | 6.3×8.0 | 0.10 | 7 | 5600 | 8×8.0 | 0.08 | 7 | 6100 | 10×12.5 | 0.12 | 12 | 5300 | |
| 680 | — | — | — | — | 8×8.0 | 0.08 | 6 | 6100 | 8×8.0 | 0.08 | 8 | 5700 | — | — | — | — | |
| 820 | 8×8.0 | 0.08 | 6 | 6100 | 8×8.0 | 0.08 | 6 | 6100 | 10×12.5 | 0.12 | 10 | 5500 | — | — | — | — | |
| 1000 | 8×8.0 | 0.08 | 6 | 6100 | 10×12.5 | 0.12 | 8 | 5500 | 10×12.5 | 0.12 | 10 | 5500 | — | — | — | — | |
| 1200 | 10×12.5 | 0.12 | 8 | 5500 | 10×12.5 | 0.12 | 8 | 5500 | — | — | — | — | — | — | — | — | |
| 1500 | 10×12.5 | 0.12 | 8 | 5500 | — | — | — | — | — | — | — | — | — | — | — | — | |

(Note) Rated ripple current : 105°C , 100kHz ; ESR : 20°C , 100kHz

MEMO

Aluminum Electrolytic Capacitors

■ Cautions for Using Aluminum Electrolytic Capacitors

Please read product specifications before using ELNA products.

The following cautions should be observed when using our aluminum electrolytic capacitors to assure their maximum stability and performance. When your application design conditions or operating conditions exceed the limit of the product specification, please contact us. If used under conditions beyond the limit of our specifications, it may cause defects such as short circuit, open circuit, leakage, explosion or combustion.

■ Cautions for usage

1. DC electrolytic capacitors are polarized.

- If used with a wrong polarity, it creates an abnormal current resulting in a short circuit or damage to itself. Use DC bipolar electrolytic capacitors for use with uncertain or unknown polarity. DC capacitors cannot be used in AC circuits.

2. Use within the rated voltage.

- If a voltage exceeding the rated voltage is applied, it may cause characteristic deterioration or damage due to the increased leakage current.
- When ripple current is loaded, make sure that the peak value of the ripple voltage does not exceed the rated voltage.

3. Using for power supply circuit.

- While aluminum electrolytic capacitors are operated electrolyte liquid inside dries up and E.S.R. (Equivalent Series Resistance) of the capacitor increases. In case operated longer than rated life time, the capacitance much decreases, tangent of loss angle and E.S.R. much increases. Therefore for some case the sum of bias direct voltage and the peak of ripple voltage is over the rated voltage of the capacitor.
- For any type of circuit, in case the sum of bias direct voltage and the peak of ripple voltage is over the rated voltage of the capacitors or in case the minimum voltage is lower than 0 (zero) volt, the voltage control for the capacitors shall be provided.

4. Do not use in a circuit which requires rapid charging or discharging.

- If used in a circuit requiring rapid charging or discharging, it may cause characteristic deterioration or damage to itself due to the heat generated inside the capacitor. In such cases, contact us for our rapid charging/discharging capacitors.

5. Use within the rated ripple current.

- If applied ripple current exceeds rated ripple current, the life of the capacitor may be shortened, or in an extreme case it gets destroyed due to its internal heat. Use high-ripple type capacitors for such circuits.

6. Changes in characteristics due to operating temperature.

- The characteristics of an electrolytic capacitor will change with a change in the temperature. Such changes are temporary and the original characteristics will be restored at the original temperature (if the characteristics are not deteriorated by remaining at a high temperature for a long time). If used at a

temperature exceeding the guaranteed temperature range, the capacitor may be damaged due to the increased leakage current. Pay attention to the capacitor temperature being affected by the ambient temperature of the unit, the temperature inside the appliance, the heat radiated by another hot component in the unit and the heat inside the capacitor itself due to the ripple current.

- (1)The electrostatic capacitance is normally shown as the value at 20°C-120Hz. It increases as the temperature raises and decreases as it lowers.
- (2)The tangent of loss angle ($\tan\delta$) is normally shown as the value at 20°C-120Hz. It decreases as the ambient temperature gets high and increases as it gets low.
- (3)The leakage current increases as the temperature gets high and decreases as it gets low.

7. Changes in the characteristics due to frequency.

- The characteristics of an electrolytic capacitor will change according to the change in the operating frequency.
- (1)The electrostatic capacity is normally shown as the value at 20°C-120Hz. It decreases as the frequency increases.
 - (2)The tangent of loss angle ($\tan\delta$) is normally shown as the value at 20°C-120Hz. It increases as the frequency gets high.
 - (3)The impedance is normally shown as the value at 100kHz 20°C. It increases as the frequency lowers.

8. Aluminum electrolytic capacitor life.

- The life of an aluminum electrolytic capacitor terminates when it fails due to the deterioration in its electronic characteristics. Temperature and the ripple current since they especially affect the life. See chart on page.

9. Changes in aluminum electrolytic capacitors during storage.

- After storage for a long period, whether unused of mounted on the appliance, the leakage current of an aluminum electrolytic capacitor will increase. This tendency is more prominent when the ambient temperature is high. If a capacitor has been stored for more than 2 years under normal temperature (shorter if high temperature) and it shows increased leakage current, a treatment by voltage application is recommended. Addition of a protective circuit in the design of the appliance is also recommended, considering the effect of the initial increased current.

NOTE : Design, Specifications are subject to change without notice.
It is recommended that you shall obtain technical specifications from ELNA to ensure that the component is suitable for your use.

10. Insulation between the capacitor case and the cathode terminal.

- The capacitor case and the cathode terminal are connected through the electrolyte which has uncertain resistance. If a complete insulation of the case is necessary, add an insulator at assembly.

11. NC terminal (the supplemental terminal) (series RPK, LJ6, LJ2)

- Since NC terminal is not insulated. It should be mounted at a position electronically independent from all other parts of the circuit.

12. External sleeve

- During a preheating or a hardening of mounting adhesive may cause a sleeve cracked. The capacitors are usually sleeved with poly vinyl chloride or poly ethylene terephthalate for the indication purpose only. Please do not consider it as an insulation.

13. Fumigation Process

- When exporting electronic equipment abroad, fumigation process may be performed on wooden packaging material with a halogen (compound) gas such as methyl bromide. Exercise care as this halogen gas may corrode capacitors. Also, use caution to epidemic preventive agent as corrosive component such as halogen may be contained.

14. Specific Operating Environments

- Capacitors may corrode when stored or used in a place filled with acidic toxic gases (such as hydrogen sulfide, sulfurous acid, nitrous acid, chlorine, bromine, methyl bromide, etc.) If capacitors are used or stored in such environments, please let us know.

15. Use at a high altitude

- The use of capacitors at high altitudes such as on an airplane causes a large difference between the internal pressure of the capacitors and the atmospheric pressure. However, there is no problem in use under atmospheric pressure up to about an altitude of 10,000 meters. Please check the operation of electronic equipment at the operating environmental temperature because the temperature lowers with increased altitude. If the condition is severe like space, please contact us.

16. Hole pitch adjustment of the PCB to the capacitors.

- Set the hole pitch of the PCB to the lead pitch (the "F" distance in the catalog) of the capacitor. Be careful since a short circuit, a cut or an increase in the leakage current etc. may be caused by the stress given to the lead wire terminals due to the difference between the hole pitch and the lead pitch.

17. Capacitors with pressure valves.

- A part of the capacitor case is made thin to have the function as the pressure valve in order to prevent explosion due to the rise of inside pressure when a reverse or excessive voltage is applied to the capacitor. Once it has worked as a valve, the whole capacitor needs to be replaced since the valve will not restore.
- When you use a capacitor with pressure valve, provide certain space above the pressure valve as below to prevent an interference when it works as a valve.

| | | |
|-------------------------------------|------------|----------|
| Diameter of the capacitor (mm) | 18 or less | 20 to 40 |
| Required space above the valve (mm) | 2.0 | 3.0 |

18. Double-sided PCB's

- When you use electrolytic capacitors on a double sided PCB, be careful not to have the circuit pattern run under where the capacitor is mounted. Otherwise it may cause a short circuit on the PCB depending on the condition of mounting.

19. Regarding to connection of capacitors

- Aluminum electrolytic capacitor has electrolyte liquid so that the most portion of electric loss characteristics came from E.S.R(Equivalent Series Resistance) of electrolyte liquid. Therefore the capacitor is an electronic devise which can flow high ripple current in case the temperature increases and it decreases E.S.R.
In case connecting two capacitors or more, E.S.R. of the capacitors is close to the resistance of the circuit. Therefore in case current is unbalanced and some capacitors has high ripple current, temperature increase, it makes more high current and finally it is over the rated ripple current.
For parallel connection of capacitors the proper design of electric circuit such as balancing of each capacitors resistance or control of total ripple current shall be provided to avoid excess ripple current and voltage.
- When two or more capacitors are arranged in series, the voltage given to each capacitors shall be kept below the rated voltage level, by also giving consideration to the balance of the voltage impressed on the capacitors. Further, partial pressure resistor which considers leakage current shall be provided parallel to each condenser not to have over-voltage impressed on.
Balance resistance are explained on p.106 of our Catalog.

■Cautions for Mounting

1. Cautions for mounting.

- Check the ratings (electrostatic capacitance and rated voltage) of the capacitor before mounting.
- Check the polarity of the capacitor to the chassis.
- Do not drop the capacitor to the floor. Do not use

NOTE : Design, Specifications are subject to change without notice. It is recommended that you shall obtain technical specifications from ELNA to ensure that the component is suitable for your use.

the dropped capacitor.

- Do not deform the capacitor for mounting.

2. Do not apply excessive pressure to the capacitor, its terminals or lead wires.

- Make sure that the contact path of the capacitor meets the hole pitch of the PCB before mounting.
- Transient recovery voltage may be generated in the capacitor due to dielectric absorption. If required, this voltage can be discharged with a resistor with a value of about 1 kΩ.
- A PCB self-standing (snap-in) type capacitor should be pushed to the end (till there is no space) to the PCB for mounting.
- Do not set the automatic insertion machine to clinch the capacitor lead wires too strong.
- Pay attention to the impact given by the component receptacles of the automatic insertion/mounting machines and the product checker, and from the centering operation.

3. Soldering.

- Do not dip the capacitor into melted solder.
- The soldering conditions
 - Chip type : Please refer to 13 page.
 - small and large type : 260°C, 10 s (max.)
 The preliminary heating and other conditions described in the catalog or product specifications.
- Do not flux other part than the terminals.
- If there is a direct contact between the sleeve of the capacitor and the printed circuit pattern or a metal part of another component such as a lead wire, it may cause shrinkage or crack.
- When you use the capacitor with its sleeve touching directly to the PCB, excessive solder temperature or excessive soldering time may cause the sleeve to shrink or crack during the heat.
- If the application is for extended use, understand and manage the soldering characteristics to avoid abnormal current caused by a contact failure between the capacitor and the PCB.

4. Handling after soldering.

- After soldering, do not tilt, push down or twist the capacitor.
- After soldering, do not hold the capacitor as a handle to carry the PCB.
- After soldering, do not hit the capacitor with any obstacle. If PCB's are piled up for storage, the capacitor should not touch another PCB or component.

5. Cleaning after Soldering

- Recommended cleaning method
 - (1)cleaning solutions:
 - (a) CLEANTHROUGH 710M, 750H, 750L
 - (b) PINEALPHA ST-100S
 - (c) Techno Care FRW-4~17
 - (d) Isopropyl alcohol (2-propanol)

(2)Cleaning conditions:

- (a) The temperature of cleaning solution shall be less than 60°C.
 - (b) Use immersion or ultrasonic waves within two minutes.
 - (c) After cleaning, capacitors and PCB's shall thoroughly be rinsed and dried with hot blast for more than 10 minutes. The temperature of such breeze should be less than the upper category temperature.
 - (d) After cleaning, do not keep capacitors in cleaning solution atmosphere or airtight containers.
- During cleaning, control the cleaning solution against contamination.

6. Fixing adhesives and coating materials.

- Do not use fixing adhesive or coating material containing halogen-based solvent.
- Before applying the fixing adhesive or the coating material, make sure that there is no remaining flux or stains between the PCB and the sealed part of the capacitor.
- Before applying the fixing adhesive or the coating material, make sure that the detergent etc. has dried up.
- Do not cover the whole surface of the sealed part (terminal side) of the capacitor with the fixing adhesive or the coating material.
- Observe the description in the catalog or the product specifications concerning the thermal stiffening conditions of the fixing adhesive or the coating material. (If there is no such description, contact us.) When both discrete and SMT components are on the same PCB, the fixing material for the SMT components may cause crack, tear or shrinkage on the external sleeve depending on the thermal stiffening condition.
- Recommended fixing adhesives and coating materials
 - Fixing adhesives : Cemedine 1500, Diabond DN83K, Bond G103
 - Coating materials : Taffy TF1159, HumiSeal 1B66NS, 1A27NS

■ Other Cautions

1. Do not touch capacitor terminals with bare hands.

You may get electric shock or your hand may be burnt. Discharge it with a 1 KΩ resistance before use if necessary.

2. Do not short the capacitor terminals with a conductor.

Do not spill conductive solution including acid or alkaline solution on the capacitor.

3. Periodical inspections should be established for the capacitors used in industrial appliances.

- The following items should be checked:

NOTE : Design, Specifications are subject to change without notice.
It is recommended that you shall obtain technical specifications from ELNA to ensure that the component is suitable for your use.

- (1) Appearance : Check if there is any open valve or leakage.
- (2) Electronic performance : Check the leakage current, the electrostatic capacitance, the tangent of loss angle and other items described in the catalog or the product specifications.

4. Take the following measures in case of emergency.

- If you see gas coming out of the capacitor valve when the set is in operation, turn off the power switch of the unit or unplug the power cord from the outlet.
- Keep your face away from the capacitor pressure valve, since the high temperature gas at over 100°C bursts out when the valve works. If the gas gets into your eyes or your mouth, wash your eyes or your mouth. Do not ingest the capacitor electrolyte. If the electrolyte gets on your skin, wash it out with soap.

5. Storing conditions.

- Avoid high temperature or high humidity when storing capacitors. Keep the storing temperature at 5°C to 35°C and the relative humidity not more than 75%.
- The leakage current of an aluminum electrolytic capacitor tends to increase when stored for a long time. This tendency becomes more prominent if the ambient temperature is high. The leakage current will be decreased by voltage application. If necessary, treatment by voltage application should

be made on the capacitors which have been stored for a long period (more than 2 years after production).

- Do not store capacitors at a place where there is a possibility that they may get water, salt or oil spill.
- Do not store capacitors at a place where the air contains dense hazardous gas (hydrogen sulfide, sulfurous acid, nitrous acid, chlorine, ammonia, etc.).
- Fumigation treatment with toxic gas covering the whole wooden container frames as moth proofing during shipment may leave residual toxic gas.
- Do not store capacitors at a place where it gets ultraviolet or radioactive rays.

6. Disposing of capacitors.

- Punch a hole or crush the capacitors (to prevent explosion) before incineration at approved facility.
- If they are not to be incinerated, bring them to a professional industrial waste disposal company.

7. Other notes.

- Please refer to the following literature for anything not described in the product specifications or the catalog.

(Technical report of Japan Electronics and Information Technology Industries Association, EIAJ RCR-2367C “Guideline of notabilia for fixed aluminum electrolytic capacitors for use in electronic equipment”)

MEMO

Chip Type Aluminum Electrolytic Capacitors

Chip Type 85°C High CV Capacitors

GREEN CAP SMD Anti-cleaning solvent

- Compatible with surface mounting.
- Supplied with carrier taping.
- Guarantees 2000 hours at 85°C.

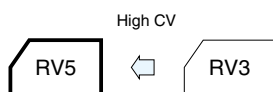

Marking color : Black print

Specifications

| Item | Performance | | | | | | | | | | | |
|--|---|---|-----|----|-----|----|----|----|----|-----|----|-----|
| Category temperature range (°C) | -40 to +85 | | | | | | | | | | | |
| Tolerance at rated capacitance (%) | ±20 (20°C, 120Hz) | | | | | | | | | | | |
| Leakage current (µA) | Less than 0.01CV or 3 whichever is larger (after 2 minutes) C : Rated capacitance (µF) ; V : Rated voltage (V) (20°C) | | | | | | | | | | | |
| Tangent of loss angle (tanδ) | Rated voltage (V) | 4 | 6.3 | 10 | 16 | 25 | 35 | 50 | 63 | 100 | | |
| | tanδ (max.) | Refer to following page. (20°C, 120Hz) | | | | | | | | | | |
| Characteristics at high and low temperature | Impedance ratio (max.) | Rated voltage (V) | | 4 | 6.3 | 10 | 16 | 25 | 35 | 50 | 63 | 100 |
| | | Z-25°C/Z+20°C | 7 | 4 | 3 | 2 | 2 | 2 | 2 | 2 | 2 | 2 |
| | | Z-40°C/Z+20°C | 17 | 10 | 8 | 6 | 4 | 3 | 3 | 3 | 3 | 3 |
| Endurance (85°C) (Applied ripple current) | Test time | 2000 hours (φ3 : 1000 hours) | | | | | | | | | | |
| | Leakage current | The initial specified value or less | | | | | | | | | | |
| | Percentage of capacitance change | Within ±30% of initial value | | | | | | | | | | |
| | Tangent of the loss angle | 200% or less of the initial specified value | | | | | | | | | | |
| Shelf life (85°C) | Test time : 1000 hours; other items are the same as those for the endurance. Voltage application treatment : According to JIS C5101-1 | | | | | | | | | | | |
| Applicable standards | JIS C5101-1 1998, -18 1999 (IEC 60384-1 1992, -18 1993) | | | | | | | | | | | |

Outline Drawing

Unit : mm

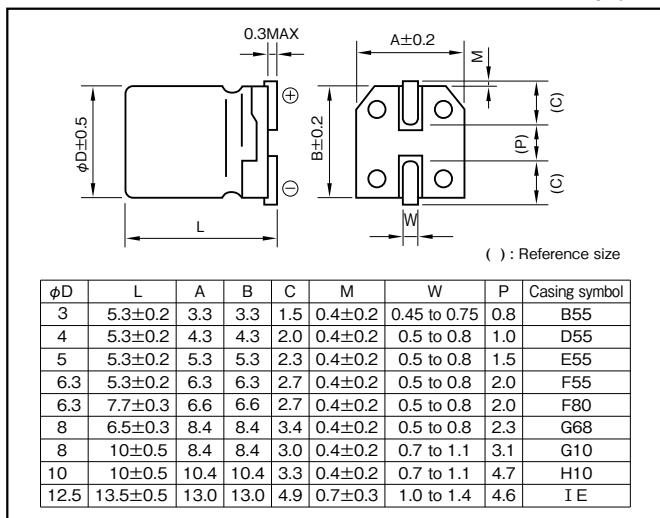

- Soldering conditions are described on page 13.
- Land pattern size are described on page 11.
- The taping specifications are described on page 14.

Coefficient of Frequency for Rated Ripple Current

| Rated voltage (V) | Frequency (Hz) | | | |
|-------------------|----------------|-----|------|------------|
| | 50 · 60 | 120 | 1k | 10k · 100k |
| 4 to 16 | 0.80 | 1 | 1.15 | 1.25 |
| 25 to 35 | 0.80 | 1 | 1.25 | 1.40 |
| 50 to 63 | 0.80 | 1 | 1.35 | 1.50 |
| 100 | 0.70 | 1 | 1.35 | 1.50 |

Part numbering system (example : 16V470µF)

| | | | | | | | | |
|-------------|---|----------------------|---|--------------------------|------------------------------|---------------|---|---------------|
| RV5 | — | 16 | V | 471 | M | G10 | U | □ |
| Series code | | Rated voltage symbol | | Rated capacitance symbol | Capacitance tolerance symbol | Casing symbol | | Taping symbol |

Standard Ratings

| Rated voltage(V) Rated capacitance(μF) | 4 | | | | 6.3 | | | | 10 | | | | 16 | | | | 25 | | | |
|---|-------------------|------------------|-------|------------------------------------|-------------------|------------------|-------|------------------------------------|-------------------|------------------|-------|------------------------------------|-------------------|------------------|-------|------------------------------------|-------------------|------------------|-------|------------------------------------|
| | Case φD×L (mm) | Casing symbol | tan δ | Rated ripple current (mArms) | Case φD×L (mm) | Casing symbol | tan δ | Rated ripple current (mArms) | Case φD×L (mm) | Casing symbol | tan δ | Rated ripple current (mArms) | Case φD×L (mm) | Casing symbol | tan δ | Rated ripple current (mArms) | Case φD×L (mm) | Casing symbol | tan δ | Rated ripple current (mArms) |
| 4.7 | - | - | - | - | - | - | - | - | - | - | - | - | - | - | - | - | 3×5.3 | B55 | 0.16 | 11 |
| 10 | - | - | - | - | - | - | - | - | 4×5.3 | D55 | 0.24 | 23 | 3×5.3 | B55 | 0.22 | 18 | 3×5.3 | B55 | 0.18 | 16 |
| 22 | 3×5.3 | B55 | 0.42 | 14 | 3×5.3 | B55 | 0.35 | 21 | 3×5.3 | B55 | 0.32 | 20 | 4×5.3 | D55 | 0.20 | 26 | 4×5.3 | D55 | 0.18 | 23 |
| 33 | 4×5.3 | D55 | 0.42 | 31 | 4×5.3 | D55 | 0.28 | 31 | 4×5.3 | D55 | 0.24 | 26 | 5×5.3 | E55 | 0.20 | 44 | 4×5.3 | D55 | 0.18 | 24 |
| 47 | 4×5.3 | D55 | 0.42 | 37 | 4×5.3 | D55 | 0.35 | 28 | 4×5.3 | D55 | 0.32 | 32 | 4×5.3 | D55 | 0.28 | 30 | 5×5.3 | E55 | 0.18 | 43 |
| 100 | 5×5.3 | E55 | 0.42 | 63 | 5×5.3 | E55 | 0.28 | 44 | 5×5.3 | E55 | 0.24 | 48 | 5×5.3 | E55 | 0.28 | 44 | 6.3×5.3 | F55 | 0.14 | 67 |
| 150 | - | - | - | - | 6.3×5.3 | F55 | 0.28 | 34 | 6.3×5.3 | F55 | 0.32 | 33 | 6.3×5.3 | F55 | 0.28 | 52 | 6.3×5.3 | F55 | 0.18 | 75 |
| 220 | 6.3×5.3 | F55 | 0.42 | 110 | 6.3×5.3 | F55 | 0.35 | 58 | 6.3×5.3 | F55 | 0.32 | 54 | 6.3×5.3 | F55 | 0.20 | 70 | 6.3×7.7 | F80 | 0.18 | 124 |
| 330 | - | - | - | - | 6.3×5.3 | F55 | 0.28 | 89 | 6.3×5.3 | F55 | 0.24 | 98 | 6.3×5.3 | F55 | 0.20 | 70 | 8×6.5 | G68 | 0.18 | 118 |
| 470 | - | - | - | - | 6.3×5.3 | F55 | 0.35 | 83 | 6.3×5.3 | F55 | 0.32 | 79 | 6.3×7.7 | F80 | 0.28 | 109 | - | - | - | - |
| 680 | - | - | - | - | 6.3×7.7 | F80 | 0.32 | 98 | 6.3×7.7 | F80 | 0.32 | 98 | 6.3×7.7 | F80 | 0.28 | 162 | - | - | - | - |
| 820 | - | - | - | - | 8×10 | G10 | 0.28 | 262 | 8×10 | G10 | 0.24 | 230 | 8×10 | G10 | 0.20 | 260 | 8×10 | G10 | 0.14 | 252 |
| 1000 | - | - | - | - | 8×10 | G10 | 0.35 | 320 | 8×10 | G10 | 0.32 | 310 | 8×10 | G10 | 0.28 | 307 | 8×10 | G10 | 0.18 | 300 |
| 1500 | - | - | - | - | 10×10 | H10 | 0.28 | 458 | 10×10 | H10 | 0.24 | 454 | 10×10 | H10 | 0.20 | 458 | 10×10 | H10 | 0.14 | 458 |
| 2200 | - | - | - | - | 10×10 | H10 | 0.35 | 489 | 12.5×13.5 | IE | 0.24 | 560 | 12.5×13.5 | IE | 0.20 | 521 | 12.5×13.5 | IE | 0.14 | 552 |
| | | | | | 12.5×13.5 | IE | 0.28 | 651 | - | - | - | - | - | - | - | - | - | - | - | - |

| Rated voltage(V) Rated capacitance(μF) | 35 | | | | 50 | | | | 63 | | | | 100 | | | |
|---|-------------------|------------------|-------|------------------------------------|-------------------|------------------|-------|------------------------------------|-------------------|------------------|-------|------------------------------------|-------------------|------------------|-------|------------------------------------|
| | Case φD×L (mm) | Casing symbol | tan δ | Rated ripple current (mArms) | Case φD×L (mm) | Casing symbol | tan δ | Rated ripple current (mArms) | Case φD×L (mm) | Casing symbol | tan δ | Rated ripple current (mArms) | Case φD×L (mm) | Casing symbol | tan δ | Rated ripple current (mArms) |
| 0.22 | - | - | - | - | 3×5.3 | B55 | 0.12 | 2 | - | - | - | - | - | - | - | - |
| 0.33 | - | - | - | - | 4×5.3 | D55 | 0.10 | 5 | - | - | - | - | - | - | - | - |
| 0.47 | - | - | - | - | 3×5.3 | B55 | 0.12 | 3 | - | - | - | - | - | - | - | - |
| 1 | - | - | - | - | 4×5.3 | D55 | 0.10 | 6 | - | - | - | - | - | - | - | - |
| 2.2 | 3×5.3 | B55 | 0.14 | 8 | 3×5.3 | B55 | 0.12 | 6 | - | - | - | - | - | - | - | - |
| 3.3 | 3×5.3 | B55 | 0.14 | 9 | 4×5.3 | D55 | 0.10 | 10 | - | - | - | - | - | - | - | - |
| 4.7 | 3×5.3 | B55 | 0.14 | 13 | 3×5.3 | B55 | 0.12 | 9 | - | - | - | - | - | - | - | - |
| 10 | 4×5.3 | D55 | 0.14 | 27 | 4×5.3 | D55 | 0.10 | 15 | 4×5.3 | D55 | 0.12 | 12 | - | - | - | - |
| 22 | 5×5.3 | E55 | 0.12 | 34 | 5×5.3 | E55 | 0.10 | 26 | 5×5.3 | E55 | 0.12 | 20 | - | - | - | - |
| 33 | 6.3×5.3 | F55 | 0.14 | 67 | 6.3×5.3 | F55 | 0.10 | 44 | 6.3×5.3 | F55 | 0.12 | 32 | 8×10 | G10 | 0.10 | 94 |
| 47 | 6.3×5.3 | F55 | 0.14 | 54 | 6.3×5.3 | F55 | 0.12 | 47 | 6.3×7.7 | F80 | 0.12 | 60 | 8×10 | G10 | 0.12 | 94 |
| 100 | 6.3×7.7 | F80 | 0.14 | 120 | 6.3×7.7 | F80 | 0.12 | 82 | 8×6.5 | G68 | 0.12 | 62 | 8×10 | G10 | 0.10 | 139 |
| 220 | 8×10 | G10 | 0.14 | 260 | 8×6.5 | G68 | 0.12 | 83 | 8×10 | G10 | 0.10 | 139 | 10×10 | H10 | 0.10 | 189 |
| 330 | 10×10 | H10 | 0.14 | 360 | 8×10 | G10 | 0.10 | 252 | 8×10 | G10 | 0.10 | 139 | 10×10 | H10 | 0.12 | 189 |
| 470 | 12.5×13.5 | IE | 0.12 | 451 | 10×10 | H10 | 0.10 | 458 | 10×10 | H10 | 0.10 | 226 | 12.5×13.5 | IE | 0.10 | 242 |
| | | | | | 12.5×13.5 | IE | 0.10 | 451 | 12.5×13.5 | IE | 0.10 | 343 | - | - | - | - |

(Note) Rated ripple current : 85° C, 120Hz

Chip Type 85°C Capacitors (height:4.5mm)

GREEN CAP

SMD

Anti-cleaning solvent

- Compatible with surface mounting for 4.5mm height capacitors.
- Supplied with carrier taping.
- Guarantees 2000 hours at 85°C.



Low Profile



Marking color : Black print

Specifications

| Item | Performance | | | | | | | |
|--|--|---|------|------|------|------|------|---|
| Category temperature range (°C) | -40 to +85 | | | | | | | |
| Tolerance at rated capacitance (%) | ±20 (20°C,120Hz) | | | | | | | |
| Leakage current (μA) | Less than 0.01CV or 3 whichever is larger (after 2 minutes) C : Rated capacitance (μF) ; V : Rated voltage (V) (20°C) | | | | | | | |
| Tangent of loss angle (tanδ) | Rated voltage (V) | 6.3 | 10 | 16 | 25 | 35 | 50 | |
| | tanδ (max.) | 0.30 | 0.24 | 0.19 | 0.16 | 0.14 | 0.12 | |
| Characteristics at high and low temperature | Rated voltage (V) | 6.3 | 10 | 16 | 25 | 35 | 50 | |
| | Impedance ratio (max.) | Z-25°C/Z+20°C | 4 | 3 | 2 | 2 | 2 | 2 |
| | | Z-40°C/Z+20°C | 8 | 8 | 4 | 4 | 3 | 3 |
| Endurance (85°C) (Applied ripple current) | Test time | 2000 hours | | | | | | |
| | Leakage current | The initial specified value or less | | | | | | |
| | Percentage of capacitance change | Within ±20% of initial value | | | | | | |
| | Tangent of the loss angle | 300% or less of the initial specified value | | | | | | |
| Shelf life (85°C) | Test time : 1000 hours ; other items are the same as those for the endurance. Voltage application treatment : According to JIS C5101-1 | | | | | | | |
| Applicable standards | JIS C5101-1 1998, -18 1999 (IEC 60384-1 1992, -18 1993) | | | | | | | |

Outline Drawing

Unit : mm

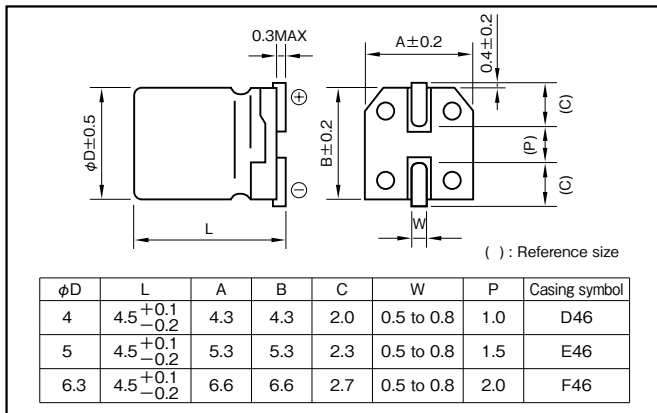

- Soldering conditions are described on page 13.
- Land pattern size are described on page 11.
- The taping specifications are described on page 14.

Coefficient of Frequency for Rated Ripple Current

| Rated voltage (V) | Frequency (Hz) | | | |
|-------------------|----------------|------|------|------------|
| | 50 · 60 | 120 | 1k | 10k · 100k |
| 6.3 to 16 | 0.80 | 1 | 1.15 | 1.25 |
| 25 to 35 | 0.70 | 1 | 1.25 | 1.40 |
| 50 | 0.1 to 3.3μF | 0.50 | 1 | 1.35 |
| | 4.7 to 10μF | 0.70 | 1 | 1.35 |

Part numbering system (example : 6.3V47M E46 U)

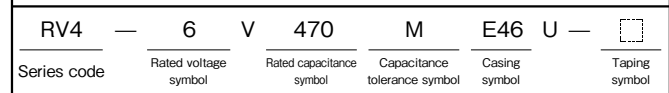

Standard Ratings

| Rated voltage (V) | 6.3 | | | 10 | | | 16 | | | 25 | | | 35 | | | 50 | | |
|-------------------|------|---------|---------------------------|------|---------|---------------------------|------|---------|---------------------------|------|---------|---------------------------|------|---------|---------------------------|------|---------|---------------------------|
| | Case | ESR (Ω) | Rated ripple current (mA) | Case | ESR (Ω) | Rated ripple current (mA) | Case | ESR (Ω) | Rated ripple current (mA) | Case | ESR (Ω) | Rated ripple current (mA) | Case | ESR (Ω) | Rated ripple current (mA) | Case | ESR (Ω) | Rated ripple current (mA) |
| 0.22 | — | — | — | — | — | — | — | — | — | — | — | — | — | — | — | 4 | 905 | 4 |
| 0.33 | — | — | — | — | — | — | — | — | — | — | — | — | — | — | — | 4 | 603 | 5 |
| 0.47 | — | — | — | — | — | — | — | — | — | — | — | — | — | — | — | 4 | 423 | 6 |
| 1 | — | — | — | — | — | — | — | — | — | — | — | — | — | — | — | 4 | 199 | 8 |
| 2.2 | — | — | — | — | — | — | — | — | — | — | — | — | — | — | — | 4 | 90 | 12 |
| 3.3 | — | — | — | — | — | — | — | — | — | — | — | — | — | — | — | 4 | 60 | 15 |
| 4.7 | — | — | — | — | — | — | — | — | — | 4 | 56 | 17 | 4 | 49 | 18 | 5 | 42 | 21 |
| 10 | — | — | — | — | — | — | 4 | 32 | 22 | 5 | 27 | 28 | 5 | 23 | 30 | 6.3 | 20 | 35 |
| 22 | 4 | 23 | 26 | 5 | 18 | 34 | 5 | 14 | 38 | 6.3 | 12 | 49 | 6.3 | 11 | 52 | — | — | — |
| 33 | 5 | 15 | 37 | 5 | 12 | 42 | 6.3 | 10 | 55 | 6.3 | 8 | 60 | — | — | — | — | — | — |
| 47 | 5 | 11 | 45 | 6.3 | 8 | 59 | 6.3 | 7 | 76 | — | — | — | — | — | — | — | — | — |
| 100 | 6.3 | 5 | 76 | — | — | — | — | — | — | — | — | — | — | — | — | — | — | — |

(Note) Rated ripple current : 85°C, 120Hz ; ESR : 20°C, 120Hz

Chip Type Bipolar Capacitors (height:5.5mm)

GREEN CAP

SMD

Anti-cleaning solvent

- Compatible with surface mounting for 5.5mm height capacitors.
- Supplied with carrier taping.
- Guarantees 2000 hours at 85°C.

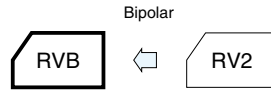

Marking color : Black print

Specifications

| Item | Performance |
|--|--|
| Category temperature range (°C) | -40 to +85 |
| Tolerance at rated capacitance (%) | ±20 (20°C, 120Hz) |
| Leakage current (µA) | Less than 0.01CV or 3 whichever is larger (after 2 minutes) C : Rated capacitance (µF) ; V : Rated voltage (V) (20°C) |
| Tangent of loss angle (tanδ) | Rated voltage (V) |
| | tanδ (max.) |
| Characteristics at high and low temperature | Rated voltage (V) |
| | Impedance ratio (max.) |
| | |
| Endurance (85°C) (Applied ripple current) | Test time |
| | Leakage current |
| | Percentage of capacitance change |
| | Tangent of the loss angle |
| Shelf life (85°C) | Test time : 1000hours; other items are the same as those for the endurance. Voltage application treatment : According to JIS C5101-1 |
| Applicable standards | JIS C5101-1 1998, -18 1999 (IEC 60384-1 1992, -18 1993) |

CHIP ALUMINUM

Outline Drawing

Unit : mm

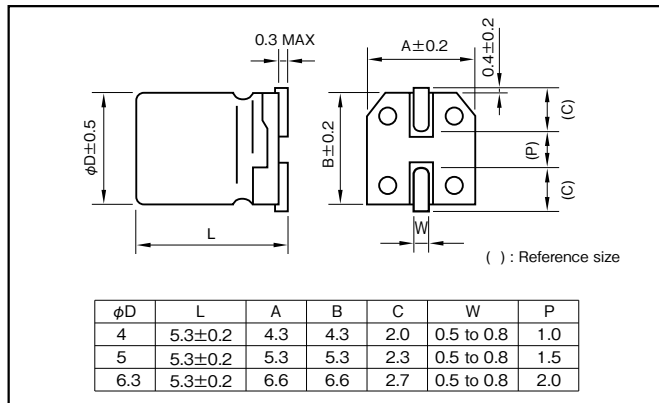

Coefficient of Frequency for Rated Ripple Current

| Frequency (Hz) | 50 · 60 | 120 | 1k | 10k · 100k |
|-------------------|---------|-----|------|------------|
| Rated voltage (V) | | | | |
| 6.3 to 16 | 0.80 | 1 | 1.15 | 1.25 |
| 25 to 35 | 0.80 | 1 | 1.25 | 1.40 |
| 50 | 0.80 | 1 | 1.35 | 1.50 |

Part numbering system (example : 6.3V47µF)

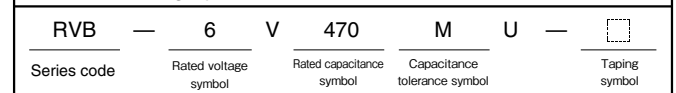

- Soldering conditions are described on page 13.
- Land pattern size are described on page 11.
- The taping specifications are described on page 14.

Standard Ratings

| Rated capacitance (µF) | 6.3 | | | 10 | | | 16 | | | 25 | | | 35 | | | 50 | | |
|------------------------|------|---------|---|------|---------|---|------|---------|---|------|---------|---|------|---------|---|------|---------|---|
| | Case | ESR (Ω) | Rated ripple current (mA _{rms}) | Case | ESR (Ω) | Rated ripple current (mA _{rms}) | Case | ESR (Ω) | Rated ripple current (mA _{rms}) | Case | ESR (Ω) | Rated ripple current (mA _{rms}) | Case | ESR (Ω) | Rated ripple current (mA _{rms}) | Case | ESR (Ω) | Rated ripple current (mA _{rms}) |
| 0.22 | — | — | — | — | — | — | — | — | — | — | — | — | — | — | — | 4 | 1510 | 3.3 |
| 0.33 | — | — | — | — | — | — | — | — | — | — | — | — | — | — | — | 4 | 1010 | 4.1 |
| 0.47 | — | — | — | — | — | — | — | — | — | — | — | — | — | — | — | 4 | 706 | 4.9 |
| 1 | — | — | — | — | — | — | — | — | — | — | — | — | — | — | — | 4 | 332 | 7.2 |
| 2.2 | — | — | — | — | — | — | — | — | — | — | — | — | 4 | 151 | 10 | 5 | 113 | 14 |
| 3.3 | — | — | — | — | — | — | — | — | — | — | — | — | 4 | 101 | 13 | 5 | 75 | 17 |
| 4.7 | — | — | — | — | — | — | 4 | 88 | 14 | 5 | 53 | 20 | 5 | 53 | 21 | 6.3 | 53 | 24 |
| 10 | — | — | — | 4 | 50 | 18 | 5 | 33 | 26 | 6.3 | 25 | 35 | 6.3 | 25 | 35 | — | — | — |
| 22 | 5 | 23 | 27 | 6.3 | 19 | 40 | 6.3 | 15 | 45 | — | — | — | — | — | — | — | — | — |
| 33 | 6.3 | 15 | 45 | 6.3 | 13 | 50 | 6.3 | 10 | 55 | — | — | — | — | — | — | — | — | — |
| 47 | 6.3 | 11 | 54 | — | — | — | — | — | — | — | — | — | — | — | — | — | — | — |

(Note) Rated ripple current : 85°C, 120Hz ; ESR : 20°C, 120Hz

Chip Type 105°C Standard Capacitors

GREEN CAP

SMD

105°C
1000hours

Anti-cleaning solvent

- Compatible with surface mounting.
- Supplied with carrier taping.
- Guarantees 1000 hours at 105°C.



High temperature



Marking color : Black print

Specifications

| Item | Performance | | | | | | |
|---|---|---|------|------|------|------|------|
| Category temperature range (°C) | -55 to +105 | | | | | | |
| Tolerance at rated capacitance (%) | ±20 (20°C, 120Hz) | | | | | | |
| Leakage current (µA) | Less than 0.01CV or 3 whichever is larger (after 2 minutes) C : Rated capacitance (µF) ; V : Rated voltage (V) (20°C) | | | | | | |
| Tangent of loss angle (tanδ) | Rated voltage (V) | 6.3 | 10 | 16 | 25 | 35 | 50 |
| | tanδ (max.) | 0.30 | 0.26 | 0.22 | 0.16 | 0.13 | 0.12 |
| Characteristics at high and low temperature | Impedance ratio (max.) | Z-25°C/Z+20°C | 4 | 3 | 2 | 2 | 2 |
| | | Z-40°C/Z+20°C | 8 | 5 | 4 | 3 | 3 |
| Endurance (105°C) (Applied ripple current) | Test time | 1000 hours | | | | | |
| | Leakage current | The initial specified value or less | | | | | |
| | Percentage of capacitance change | Within ±20% of initial value | | | | | |
| | Tangent of the loss angle | 200% or less of the initial specified value | | | | | |
| Shelf life (105°C) | Test time : 1000 hours; other items are the same as those for the endurance. Voltage application treatment : According to JIS C5101-1 | | | | | | |
| Applicable standards | JIS C5101-1 1998, -18 1999 (IEC 60384-1 1992, -18 1993) | | | | | | |

Outline Drawing

Unit : mm

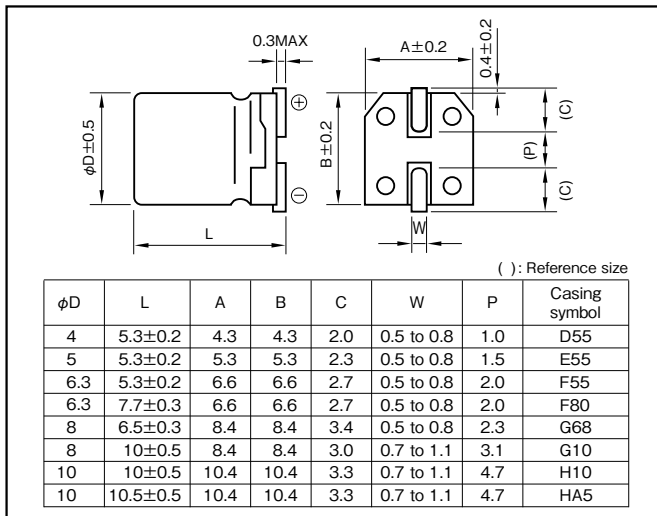

Coefficient of Frequency for Rated Ripple Current

| Frequency (Hz) | 50·60 | 120 | 1k | 10k·100k |
|-------------------|-------|-----|------|----------|
| Rated voltage (V) | | | | |
| 6.3 to 16 | 0.80 | 1 | 1.15 | 1.25 |
| 25 to 35 | 0.80 | 1 | 1.25 | 1.40 |
| 50 | 0.80 | 1 | 1.35 | 1.50 |

Part numbering system (example : 16V47µF)

| | | | | | | | | |
|-------------|---|----------------------|---|--------------------------|------------------------------|---------------|---|---------------|
| RVS | — | 16 | V | 470 | M | F55 | U | □ |
| Series code | | Rated voltage symbol | | Rated capacitance symbol | Capacitance tolerance symbol | Casing symbol | | Taping symbol |

- Soldering conditions are described on page 13.
- Land pattern size are described on page 11.
- The taping specifications are described on page 14.

Standard Ratings

| Rated capacitance (μF) | Rated voltage (V) | 6.3 | | | 10 | | | 16 | | | 25 | | | 35 | | | 50 | | |
|------------------------|-------------------|----------|-----|----------------------|----------|-----|----------------------|----------|-----|----------------------|----------|-----|----------------------|----------|-----|----------------------|----------|-----|----------------------|
| | | Case | ESR | Rated ripple current | Case | ESR | Rated ripple current | Case | ESR | Rated ripple current | Case | ESR | Rated ripple current | Case | ESR | Rated ripple current | Case | ESR | Rated ripple current |
| | | φD×L(mm) | (Ω) | (mAmps) | φD×L(mm) | (Ω) | (mAmps) | φD×L(mm) | (Ω) | (mAmps) | φD×L(mm) | (Ω) | (mAmps) | φD×L(mm) | (Ω) | (mAmps) | φD×L(mm) | (Ω) | (mAmps) |
| 0.22 | — | — | — | — | — | — | — | — | — | — | — | — | — | — | — | 4×5.3 | 905 | 3 | |
| 0.33 | — | — | — | — | — | — | — | — | — | — | — | — | — | — | — | 4×5.3 | 603 | 4 | |
| 0.47 | — | — | — | — | — | — | — | — | — | — | — | — | — | — | — | 4×5.3 | 424 | 5 | |
| 1 | — | — | — | — | — | — | — | — | — | — | — | — | — | — | — | 4×5.3 | 199 | 7 | |
| 2.2 | — | — | — | — | — | — | — | — | — | — | — | — | — | — | — | 4×5.3 | 91 | 10 | |
| 3.3 | — | — | — | — | — | — | — | — | — | — | — | — | — | — | — | 4×5.3 | 60 | 12 | |
| 4.7 | — | — | — | — | — | — | — | — | — | 4×5.3 | 57 | 12 | 4×5.3 | 46 | 14 | 5×5.3 | 42 | 17 | |
| 10 | — | — | — | 4×5.3 | 43 | 15 | 4×5.3 | 36 | 16 | 5×5.3 | 27 | 21 | 5×5.3 | 22 | 23 | 6.3×5.3 | 20 | 26 | |
| 22 | 4×5.3 | 23 | 21 | 5×5.3 | 20 | 25 | 5×5.3 | 17 | 28 | 6.3×5.3 | 12 | 36 | 6.3×5.3 | 10 | 50 | 8×6.5 | 9.0 | 51 | |
| 33 | 5×5.3 | 15 | 30 | 5×5.3 | 13 | 31 | 6.3×5.3 | 11 | 40 | 6.3×5.3 | 8.0 | 44 | 8×6.5 | 6.5 | 59 | 6.3×7.7 | 6.0 | 60 | |
| 47 | 5×5.3 | 11 | 36 | 6.3×5.3 | 9.2 | 43 | 6.3×5.3 | 7.8 | 47 | 8×6.5 | 5.6 | 66 | — | — | — | 6.3×7.7 | 4.2 | 63 | |
| 100 | 6.3×5.3 | 5.0 | 61 | 6.3×5.3 | 4.3 | 60 | 6.3×5.3 | 3.6 | 60 | 6.3×7.7 | 2.7 | 91 | 6.3×7.7 | 2.2 | 84 | 8×10 | 2.0 | 140 | |
| 150 | — | — | — | — | — | — | 6.3×7.7 | 2.4 | 105 | 8×10 | 1.8 | 140 | 8×10 | 1.4 | 155 | 10×10 | 1.3 | 180 | |
| 220 | 8×6.5 | 2.3 | 102 | 6.3×7.7 | 2.0 | 105 | 6.3×7.7 | 1.7 | 105 | 8×10 | 1.2 | 155 | 8×10 | 0.98 | 190 | 10×10.5 | 0.91 | 220 | |
| 330 | 6.3×7.7 | 1.5 | 105 | 8×10 | 1.3 | 195 | 8×10 | 1.1 | 195 | 8×10 | 0.80 | 190 | 10×10.5 | 0.65 | 300 | — | — | — | |
| 470 | 8×10 | 1.1 | 210 | 8×10 | 0.92 | 210 | 8×10 | 0.78 | 230 | 10×10 | 0.57 | 300 | — | — | — | — | — | — | |
| 680 | 8×10 | 0.73 | 210 | 10×10 | 0.63 | 310 | 10×10 | 0.54 | 310 | — | — | — | — | — | — | — | — | — | |
| 1000 | 8×10 | 0.50 | 210 | 10×10 | 0.43 | 310 | — | — | — | — | — | — | — | — | — | — | — | — | |
| 1500 | 10×10 | 0.33 | 310 | — | — | — | — | — | — | — | — | — | — | — | — | — | — | — | |

(Note) Rated ripple current : 105°C , 120Hz ; ESR : 20°C , 120Hz

Chip Type 105°C Capacitors (height:6.0mm)

GREEN CAP

SMD

105°C
2000hours

Anti-cleaning solvent

- Compatible with surface mounting for 6.0mm height capacitors.
- Supplied with carrier taping.
- Guarantees 2000 hours at 105°C.

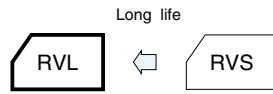

Marking color : Black print

Specifications

| Item | Performance | | | | | | |
|---|---|---|------|------|------|------|------|
| Category temperature range (°C) | -55 to +105 | | | | | | |
| Tolerance at rated capacitance (%) | ±20 (20°C,120Hz) | | | | | | |
| Leakage current (μA) | Less than 0.01CV or 3 whichever is larger (after 2 minutes) C : Rated capacitance (μF) ; V : Rated voltage (V) (20°C) | | | | | | |
| Tangent of loss angle (tanδ) | Rated voltage (V) | 6.3 | 10 | 16 | 25 | 35 | 50 |
| | tanδ (max.) | 0.32 | 0.28 | 0.24 | 0.18 | 0.15 | 0.14 |
| Characteristics at high and low temperature | Impedance ratio (max.) | Z-25°C/Z+20°C | 4 | 3 | 2 | 2 | 2 |
| | | Z-40°C/Z+20°C | 8 | 5 | 4 | 3 | 3 |
| Endurance (105°C) (Applied ripple current) | Test time | 2000 hours | | | | | |
| | Leakage current | The initial specified value or less | | | | | |
| | Percentage of capacitance change | Within ±30% of initial value | | | | | |
| | Tangent of the loss angle | 300% or less of the initial specified value | | | | | |
| Shelf life (105°C) | Test time : 1000hours ; other items are the same as those for the endurance. Voltage application treatment : According to JIS C5101-1 | | | | | | |
| Applicable standards | JIS C5101-1 1998, -18 1999 (IEC 60384-1 1992, -18 1993) | | | | | | |

Outline Drawing

Unit : mm

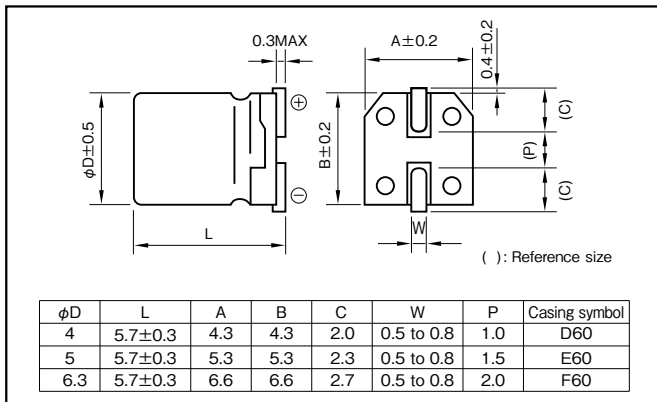

- Soldering conditions are described on page 13.
- Land pattern size are described on page 11.
- The taping specifications are described on page 14.

Coefficient of Frequency for Rated Ripple Current

| Rated voltage (V) | Frequency (Hz) | | | |
|-------------------|----------------|------|------|------------|
| | 50 · 60 | 120 | 1k | 10k · 100k |
| 6.3 to 16 | 0.80 | 1 | 1.15 | 1.25 |
| 25 · 35 | 0.80 | 1 | 1.25 | 1.40 |
| 50 | 0.1 to 3.3μF | 0.50 | 1 | 1.35 |
| | 4.7 to 10μF | 0.70 | 1 | 1.35 |

Part numbering system (example : 16V47μF)

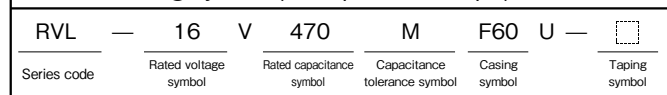

Standard Ratings

| Rated capacitance (μF) | 6.3 | | | 10 | | | 16 | | | 25 | | | 35 | | | 50 | | |
|------------------------|---------|---------|------------------------------|---------|---------|------------------------------|---------|---------|------------------------------|---------|---------|------------------------------|---------|---------|------------------------------|---------|---------|------------------------------|
| | Case | ESR (Ω) | Rated ripple current (mAmps) | Case | ESR (Ω) | Rated ripple current (mAmps) | Case | ESR (Ω) | Rated ripple current (mAmps) | Case | ESR (Ω) | Rated ripple current (mAmps) | Case | ESR (Ω) | Rated ripple current (mAmps) | Case | ESR (Ω) | Rated ripple current (mAmps) |
| 0.22 | — | — | — | — | — | — | — | — | — | — | — | — | — | — | — | 4×5.7 | 1055 | 5 |
| 0.33 | — | — | — | — | — | — | — | — | — | — | — | — | — | — | — | 4×5.7 | 703 | 6 |
| 0.47 | — | — | — | — | — | — | — | — | — | — | — | — | — | — | — | 4×5.7 | 494 | 7 |
| 1 | — | — | — | — | — | — | — | — | — | — | — | — | — | — | — | 4×5.7 | 232 | 12 |
| 2.2 | — | — | — | — | — | — | — | — | — | — | — | — | — | — | — | 4×5.7 | 105 | 19 |
| 3.3 | — | — | — | — | — | — | — | — | — | — | — | — | — | — | — | 4×5.7 | 70 | 22 |
| 4.7 | — | — | — | — | — | — | — | — | — | 4×5.7 | 63 | 21 | 4×5.7 | 53 | 23 | 5×5.7 | 49 | 29 |
| 10 | — | — | — | — | — | — | 4×5.7 | 40 | 27 | 5×5.7 | 30 | 36 | 5×5.7 | 25 | 39 | 6.3×5.7 | 23 | 47 |
| 22 | — | — | — | — | — | — | 5×5.7 | 18 | 46 | 6.3×5.7 | 14 | 62 | 6.3×5.7 | 11 | 65 | — | — | — |
| 33 | — | — | — | — | — | — | 6.3×5.7 | 12 | 66 | 6.3×5.7 | 9.0 | 76 | — | — | — | — | — | — |
| 47 | — | — | — | 6.3×5.7 | 9.9 | 74 | 6.3×5.7 | 8.5 | 78 | — | — | — | — | — | — | — | — | — |
| 100 | 6.3×5.7 | 5.3 | 99 | — | — | — | — | — | — | — | — | — | — | — | — | — | — | — |

(Note) Rated ripple current : 105°C, 120Hz ; ESR : 20°C, 120Hz

Chip Type, 105°C Use, Large Capacitance Capacitors

GREEN CAP

SMD

105°C
2000hours

Anti-cleaning solvent

- Compatible with surface mounting.
- Supplied with carrier taping.
- Guarantees 2000 hours at 105°C.
($\phi 12.5 \times 13.5L$: 5000 hours at 105°C)



High temperature



Marking color : Black print ($\phi 8 \times 6.5L$)
White print on a brown sleeve ($\phi 8 \times 10L - \phi 12.5 \times 13.5L$)

Specifications

| Item | Performance | | | | | | | | | |
|---|--|---|------|------|------|------|------|------|------|---------------|
| Category temperature range (°C) | -55 to +105 | | | | | | | | | |
| Tolerance at rated capacitance (%) | ± 20 (20°C, 120Hz) | | | | | | | | | |
| Leakage current (μA) | Less than 0.01CV or 3 whichever is larger (after 2 minutes) C : Rated capacitance (μF) ; V : Rated voltage (V) (20°C) | | | | | | | | | |
| Tangent of loss angle (tan δ) | Rated voltage (V) | 6.3 | 10 | 16 | 25 | 35 | 50 | 63 | 100 | |
| | tan δ (max.) | 0.30 | 0.24 | 0.22 | 0.16 | 0.13 | 0.12 | 0.11 | 0.10 | (20°C, 120Hz) |
| Characteristics at high and low temperature | Rated voltage (V) | 6.3 | 10 | 16 | 25 | 35 | 50 | 63 | 100 | |
| | Impedance ratio (max.) | Z-25°C/Z+20°C | 4 | 3 | 2 | 2 | 2 | 2 | 2 | 2 |
| Endurance (105°C) (Applied ripple current) | Test time | 2000 hours ($\phi 12.5 \times 13.5L$: 5000 hours) | | | | | | | | |
| | Leakage current | The initial specified value or less | | | | | | | | |
| | Percentage of capacitance change | Within $\pm 20\%$ of initial value | | | | | | | | |
| | Tangent of the loss angle | 200% or less of the initial specified value | | | | | | | | |
| Shelf life (105°C) | Test time : 1000 hours ; other items are the same as those for the endurance. Voltage application treatment : According to JIS C5101-1 | | | | | | | | | |
| Applicable standards | JIS C 5101-1 1998, -18 1999 (IEC 60384-1 1992, -18 1993) | | | | | | | | | |

Outline Drawing

Unit : mm

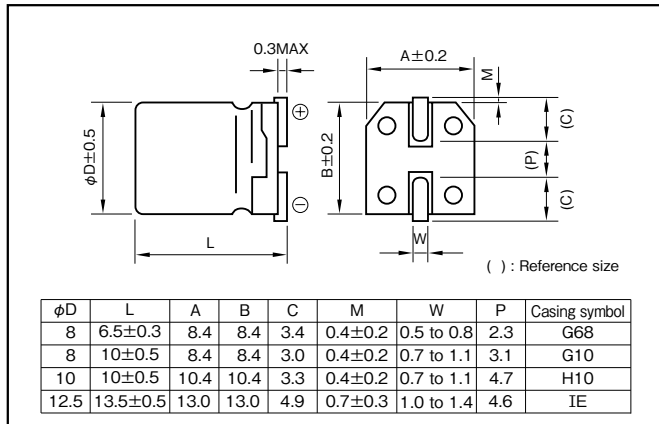

- Soldering conditions are described on page 13.
- Land pattern size are described on page 11.
- The taping specifications are described on page 14.

Coefficient of Frequency for Rated Ripple Current

| Rated voltage (V) | Frequency (Hz) | | | |
|-------------------|----------------|-----|------|------------|
| | 50 · 60 | 120 | 1k | 10k · 100k |
| 6.3 to 16 | 0.80 | 1 | 1.15 | 1.25 |
| 25 to 35 | 0.80 | 1 | 1.25 | 1.40 |
| 50 to 63 | 0.80 | 1 | 1.35 | 1.50 |
| 100 | 0.70 | 1 | 1.35 | 1.50 |

| Rated capacitance (μF) | Frequency (Hz) | | | |
|-------------------------------|----------------|------|------|------|
| | 120 | 1k | 10k | 100k |
| 47 | 0.50 | 0.76 | 0.87 | 1 |
| 100 to 220 | 0.70 | 0.85 | 0.90 | 1 |
| 330 to 1000 | 0.80 | 0.93 | 0.98 | 1 |

Part numbering system

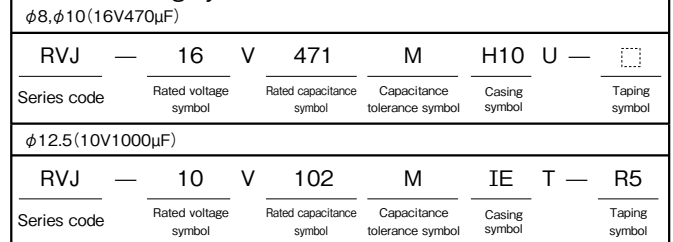

Standard Ratings

| Rated capacitance (μF) | 6.3 | | 10 | | 16 | | 25 | | 35 | | 50 | | 63 | | 100 | | | | |
|-------------------------------|-----------|---------------------------|------|---------------------------|------|---------------------------|-------|---------------------------|------|---------------------------|------|---------------------------|-----------|---------------------------|------|---------------------------|-----|-----|---|
| | Case | Rated ripple current (mA) | Case | Rated ripple current (mA) | Case | Rated ripple current (mA) | Case | Rated ripple current (mA) | Case | Rated ripple current (mA) | Case | Rated ripple current (mA) | Case | Rated ripple current (mA) | Case | Rated ripple current (mA) | | | |
| 10 | — | — | — | — | — | — | — | — | — | — | — | — | — | — | — | — | | | |
| 22 | — | — | — | — | — | — | — | — | — | — | — | — | — | — | — | — | | | |
| 33 | — | — | — | — | — | — | — | — | — | — | — | — | — | — | — | — | | | |
| 47 | — | — | — | — | — | — | — | — | — | — | — | — | — | — | — | — | | | |
| 100 | — | — | — | — | — | — | — | — | — | — | — | — | — | — | — | — | | | |
| | — | — | — | — | — | — | — | — | — | — | — | — | — | — | — | — | | | |
| 220 | 8x10 | G10 | 178 | 8x10 | G10 | 178 | 10x10 | H10 | 324 | 10x10 | H10 | 324 | 10x10 | H10 | 324 | 10x10 | H10 | 324 | |
| 330 | 8x10 | G10 | 178 | 10x10 | H10 | 324 | 10x10 | H10 | 324 | 10x10 | H10 | 324 | 12.5x13.5 | IE | 747* | — | — | — | — |
| 470 | 10x10 | H10 | 324 | 10x10 | H10 | 324 | 10x10 | H10 | 324 | 12.5x13.5 | IE | 747* | 12.5x13.5 | IE | 747* | — | — | — | — |
| 1000 | 10x10 | H10 | 324 | 10x10 | H10 | 324 | — | — | — | — | — | — | — | — | — | — | — | — | — |
| | 12.5x13.5 | IE | 747* | 12.5x13.5 | IE | 747* | — | — | — | — | — | — | — | — | — | — | — | — | — |

NOTE : Design, Specifications are subject to change without notice.
It is recommended that you shall obtain technical specifications from ELNA to ensure that the component is suitable for your use.

Chip type, 105°C Use, Long Life, High CV Capacitors

GREEN CAP

SMD

105°C
2000hours

Anti-cleaning solvent

- Compatible with surface mounting.
- Supplied with carrier taping.
- Guarantees 2000 hours 105°C.

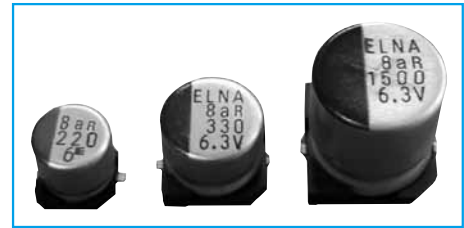
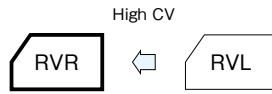

Marking color : Black print

Specifications

| Item | Performance | | | | | | | | |
|---|--|--|------|------|------|------|------|------|----|
| Category temperature range (°C) | -40 to +105 | | | | | | | | |
| Tolerance at rated capacitance (%) | ±20 (20°C, 120Hz) | | | | | | | | |
| Leakage current (µA) | Less than 0.01CV or 3 whichever is larger (after 2 minutes) C : Rated capacitance (µF), V : Rated voltage (V) (20°C) | | | | | | | | |
| Tangent of loss angle (tanδ) | Rated voltage (V) | 4 | 6.3 | 10 | 16 | 25 | 35 | 50 | |
| | tanδ (max.) | 0.50 | 0.30 | 0.22 | 0.16 | 0.14 | 0.12 | 0.12 | |
| Characteristics at high and low temperature | Impedance ratio (max.) | Rated voltage (V) | 4 | 6.3 | 10 | 16 | 25 | 35 | 50 |
| | | Z-25°C/Z+20°C | 7 | 4 | 3 | 2 | 2 | 2 | 2 |
| | Z-40°C/Z+20°C | 15 | 8 | 6 | 4 | 4 | 3 | 3 | |
| Endurance (105°C) | Test time | 2000 hours | | | | | | | |
| | Leakage current | The initial specified value or less | | | | | | | |
| | Percentage of capacitance change | Within ±20% of initial value (φ5 or Smaller & 16V or less: ±30%) | | | | | | | |
| | Tangent of loss angle | 200% or less of the initial specified value | | | | | | | |
| Shelf life (105°C) | Test time : 1000 hours ; other items are the same as those for the endurance. Voltage application treatment | | | | | | | | |
| Applicable standards | JIS C5101-1 1998, -18 1999 (IEC 60384-1 1992, -18 1993) | | | | | | | | |

Outline Drawing

Unit : mm

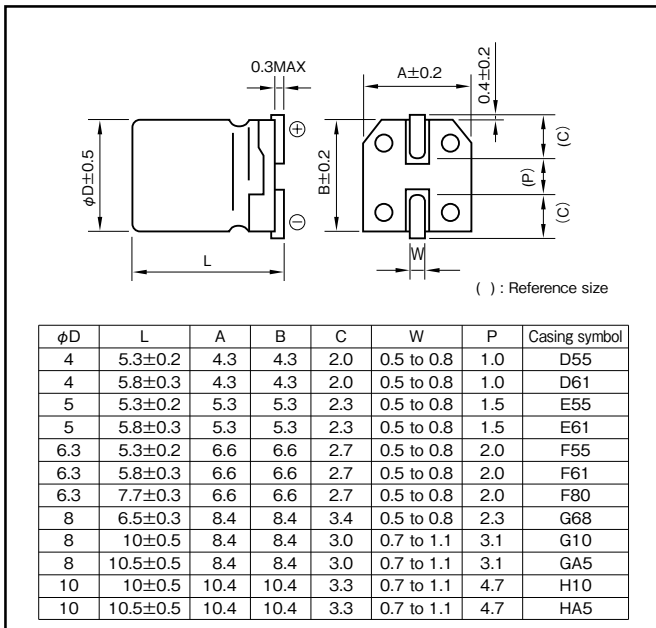

- Soldering conditions are described on page 13.
- Land pattern size are described on page 11.
- The taping specifications are described on page 14.

Coefficient of Frequency for Rated Ripple Current

| Frequency (Hz) | 50 - 60 | 120 | 1k | 10k · 100k |
|-------------------|---------|-----|------|------------|
| Rated voltage (V) | | | | |
| 6.3 to 16 | 0.80 | 1 | 1.15 | 1.25 |
| 25 to 35 | 0.80 | 1 | 1.25 | 1.40 |
| 50 | 0.50 | 1 | 1.35 | 1.50 |

Part numbering system (example : 16V100µF)

| | | | | | | | | | |
|-------------|---|----------------------|---|--------------------------|------------------------------|---------------|---|---|---------------|
| RVR | — | 16 | V | 101 | M | F61 | U | — | □ |
| Series code | | Rated voltage symbol | | Rated capacitance symbol | Capacitance tolerance symbol | Casing symbol | | | Taping symbol |

Standard Ratings

| Rated voltage(V) Rated capacitance(μF) | Item | 4 | | | 6.3 | | | 10 | | | 16 | | | 25 | | | | | |
|---|---------|-------------------|------------------|------------------------------------|-------------------|------------------|------------------------------------|-------------------|------------------|------------------------------------|-------------------|------------------|------------------------------------|-------------------|------------------|------------------------------------|---------|-----|-----|
| | | Case φD×L (mm) | Casing symbol | Rated ripple current (mArms) | Case φD×L (mm) | Casing symbol | Rated ripple current (mArms) | Case φD×L (mm) | Casing symbol | Rated ripple current (mArms) | Case φD×L (mm) | Casing symbol | Rated ripple current (mArms) | Case φD×L (mm) | Casing symbol | Rated ripple current (mArms) | | | |
| 4.7 | | - | - | - | - | - | - | - | - | - | - | - | - | 4×5.3 | D55 | 22 | | | |
| 6.8 | | - | - | - | - | - | - | - | - | - | - | - | - | 4×5.3 | D55 | 25 | | | |
| 10 | | - | - | - | - | - | - | - | - | - | 4×5.3 | D55 | 25 | 4×5.8 | D61 | 36 | | | |
| 22 | | | | | 4×5.3 | D55 | 26 | 4×5.8 | D61 | 33 | 4×5.8 | D61 | 27 | 5×5.8 | E61 | 48 | | | |
| | | | | | 4×5.8 | D61 | 28 | | | | 4×5.8 | D61 | 39 | | | | 5×5.3 | E55 | 39 |
| 33 | | | | | 5×5.8 | E61 | 40 | 6.3×5.8 | F61 | 74 | 4×5.8 | D61 | 41 | 5×5.8 | E61 | 59 | | | |
| | | | | | | | | | | | 5×5.3 | E55 | 43 | 6.3×5.8 | F61 | 66 | 6.3×5.3 | F55 | 65 |
| | | | | | | | | | | | 5×5.8 | E61 | 47 | 6.3×5.8 | F61 | 66 | 6.3×5.8 | F61 | 69 |
| 47 | 4×5.8 | D61 | 42 | 4×5.8 | D61 | 42 | 6.3×5.8 | F61 | 74 | 5×5.8 | E61 | 66 | 6.3×5.8 | F61 | 82 | | | | |
| | | | | 5×5.3 | E55 | 46 | | | | 6.3×5.3 | F55 | 70 | | | | | | | |
| | | | | 5×5.8 | E61 | 48 | | | | 6.3×5.8 | F61 | 78 | | | | | | | |
| | | | | 5×5.8 | E61 | 70 | | | | 6.3×5.8 | F61 | 112 | | | | | | | |
| 100 | 5×5.8 | E61 | 70 | 6.3×5.3 | F55 | 71 | 6.3×5.8 | F61 | 95 | 6.3×5.8 | F61 | 112 | 6.3×7.7 | F80 | 132 | | | | |
| | | | | 6.3×5.8 | F61 | 99 | | | | | | | 8×6.5 | G68 | 146 | | | | |
| | | | | 6.3×5.8 | F61 | 99 | | | | | | | 8×6.5 | G68 | 146 | | | | |
| 150 | | | | | | | 6.3×5.8 | F61 | 117 | 8×6.5 | G68 | 151 | - | - | - | | | | |
| 220 | 6.3×5.8 | F61 | 121 | 6.3×5.8 | F61 | 121 | 6.3×7.7 | F80 | 156 | 6.3×7.7 | F80 | 183 | 8×10 | G10 | 320 | | | | |
| | | | | | | | 8×6.5 | G68 | 173 | 8×6.5 | G68 | 157 | 8×10.5 | GA5 | 340 | | | | |
| 330 | 6.3×7.7 | F80 | 163 | 6.3×7.7 | F80 | 163 | 8×10 | G10 | 296 | 8×10.5 | GA5 | 291 | 8×10.5 | GA5 | 340 | | | | |
| | 8×6.5 | G68 | 181 | 8×6.5 | G68 | 181 | 8×10.5 | GA5 | 296 | | | | | | | | | | |
| 470 | | | | 8×10 | G10 | 320 | 8×10 | G10 | 326 | 8×10 | G10 | 348 | 10×10.5 | HA5 | 490 | | | | |
| | | | | 8×10.5 | GA5 | 320 | 8×10.5 | GA5 | 326 | 8×10.5 | GA5 | 348 | | | | | | | |
| 680 | | | | 8×10.5 | GA5 | 340 | 10×10 | H10 | 440 | 10×10 | H10 | 484 | - | - | - | | | | |
| 820 | | | | | | | | | | | 10×10.5 | HA5 | 484 | | | | | | |
| | | | | | | | | | | | | | | | | | 10×10 | H10 | 440 |
| | | | | | | | | | | | | | | | | | 10×10.5 | HA5 | 440 |
| 1000 | | | | 8×10.5 | GA5 | 370 | 10×10.5 | HA5 | 500 | | | | | | | | | | |
| | | | | 10×10 | H10 | 495 | | | | | | | | | | | | | |
| | | | | 10×10.5 | HA5 | 495 | | | | | | | | | | | | | |
| 1200 | | | | | | | 10×10.5 | HA5 | 500 | | | | | | | | | | |
| 1500 | | | | 10×10.5 | HA5 | 550 | | | | | | | | | | | | | |

CHIP
ALUMINUM

| Rated voltage(V) Rated capacitance(μF) | Item | 35 | | | 50 | | |
|---|---------|-------------------|------------------|------------------------------------|-------------------|------------------|------------------------------------|
| | | Case φD×L (mm) | Casing symbol | Rated ripple current (mArms) | Case φD×L (mm) | Casing symbol | Rated ripple current (mArms) |
| 0.22 | | - | - | - | 4×5.3 | D55 | 2 |
| 0.33 | | - | - | - | 4×5.3 | D55 | 3 |
| 0.47 | | - | - | - | 4×5.3 | D55 | 5 |
| 1 | | | | | 4×5.3 | D55 | 10 |
| | | | | | 4×5.8 | D61 | 12 |
| 2.2 | | | | | 4×5.3 | D55 | 16 |
| | | | | | 4×5.8 | D61 | 19 |
| 3.3 | | | | | 4×5.3 | D55 | 16 |
| | | | | | 4×5.8 | D61 | 22 |
| 4.7 | 4×5.8 | D61 | 23 | 4×5.8 | D61 | 26 | |
| | | | | 5×5.3 | E55 | 23 | |
| | | | | 5×5.8 | E61 | 29 | |
| 6.8 | | | | 5×5.3 | E55 | 23 | |
| 10 | 4×5.8 | D61 | 30 | 5×5.8 | E61 | 35 | |
| | 5×5.3 | E55 | 28 | 6.3×5.3 | F55 | 35 | |
| | 5×5.8 | E61 | 39 | 6.3×5.8 | F61 | 47 | |
| 22 | 5×5.8 | E61 | 52 | 6.3×5.8 | F61 | 61 | |
| | 6.3×5.3 | F55 | 55 | | | | |
| 33 | 6.3×5.8 | F61 | 74 | 6.3×7.7 | F80 | 82 | |
| | | | | 8×6.5 | G68 | 91 | |
| 47 | 6.3×5.8 | F61 | 89 | 6.3×7.7 | F80 | 97 | |
| | | | | 8×6.5 | G68 | 108 | |
| 68 | 6.3×7.7 | F80 | 117 | | | | |
| | 8×6.5 | G68 | 130 | | | | |
| 100 | 6.3×7.7 | F80 | 142 | 8×10.5 | GA5 | 230 | |
| | 8×6.5 | G68 | 158 | | | | |
| | 8×10 | G10 | 283 | | | | |
| | 8×10.5 | GA5 | 283 | | | | |
| 150 | 8×10 | G10 | 293 | 10×10.5 | HA5 | 300 | |
| | 8×10.5 | GA5 | 293 | | | | |
| 220 | 8×10.5 | GA5 | 302 | 10×10.5 | HA5 | 375 | |
| | 10×10 | H10 | 450 | | | | |
| 330 | 10×10.5 | HA5 | 450 | | | | |

(Note) Rated ripple current : 105° C, 120Hz

NOTE : Design, Specifications are subject to change without notice.
It is recommended that you shall obtain technical specifications from ELNA to ensure that the component is suitable for your use.

Chip Type, 105°C Use, Long Life Capacitors

GREEN CAP

SMD

105°C
3000hours

Anti-cleaning solvent

- Compatible with surface mounting.
- Supplied with carrier taping.
- Guarantees 3000 hours at 105°C. (10L:5000 hours).

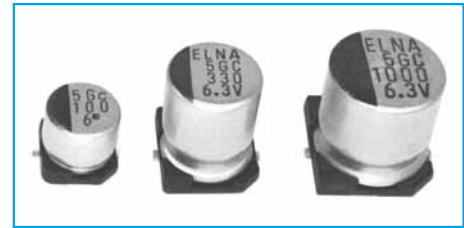
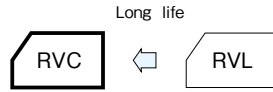

Marking color : Black print

Specifications

| Item | Performance | | | | | | |
|---|--|---|------|------|------|------|------|
| Category temperature range (°C) | -40 to +105 | | | | | | |
| Tolerance at rated capacitance (%) | ±20 (20°C, 120Hz) | | | | | | |
| Leakage current (μA) | Less than 0.01CV or 3 whichever is larger (after 2 minutes) C : Rated capacitance (μF), V : Rated voltage (V) (20°C) | | | | | | |
| Tangent of loss angle (tanδ) | Rated voltage (V) | 6.3 | 10 | 16 | 25 | 35 | 50 |
| | tanδ (max.) | 0.28 | 0.24 | 0.20 | 0.16 | 0.13 | 0.12 |
| Characteristics at high and low temperature | Impedance ratio (max.) | Z-25°C/Z+20°C | 4 | 3 | 2 | 2 | 2 |
| | | Z-40°C/Z+20°C | 10 | 7 | 5 | 3 | 3 |
| Endurance (105°C) | Test time | 3000 hours (10L : 5000 hours) | | | | | |
| | Leakage current | The initial specified value or less | | | | | |
| | Percentage of capacitance change | Within ±30% of initial value | | | | | |
| | Tangent of the loss angle | 300% or less of initial specified value | | | | | |
| Shelf life (105°C) | Test time : 1000 hours ; other items are the same as those for the endurance. Voltage application treatment : According to JIS C5101-1 | | | | | | |
| Applicable standards | JIS C5101-1 1998, -18 1999 (IEC 60384-1 1992, -18 1993) | | | | | | |

Outline Drawing

Unit : mm

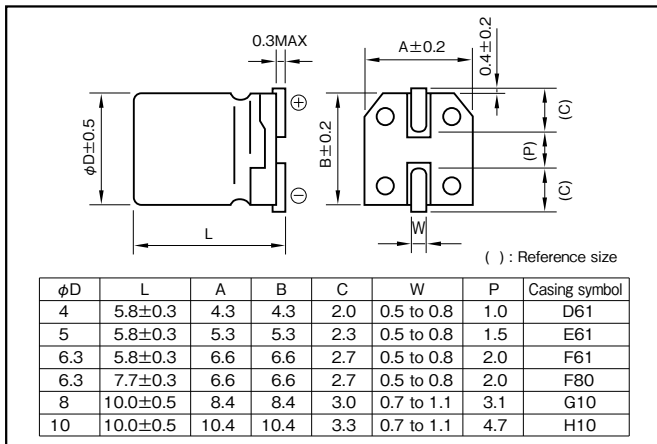

- Soldering conditions are described on page 13.
- Land pattern size are described on page 11.
- The taping specifications are described on page 14.

Coefficient of Frequency for Rated Ripple Current

| Rated voltage (V) \ Frequency (Hz) | 50 | 120 | 1k | 10k·100k |
|------------------------------------|--------------|-----|------|----------|
| 6.3 to 16 | 0.8 | 1 | 1.15 | 1.25 |
| 25 to 35 | 0.8 | 1 | 1.25 | 1.40 |
| 50 | 0.1 to 3.3μF | 0.5 | 1 | 1.35 |
| 50 | 4.7 or more | 0.7 | 1 | 1.35 |

Part numbering system (example : 16V47μF)

| | | | | | | | | | |
|-------------|---|----------------------|---|--------------------------|------------------------------|---------------|---|---|---------------|
| RVC | — | 16 | V | 470 | M | F61 | U | — | □ |
| Series code | | Rated voltage symbol | | Rated capacitance symbol | Capacitance tolerance symbol | Casing symbol | | | Taping symbol |

NOTE : Design, Specifications are subject to change without notice. It is recommended that you shall obtain technical specifications from ELNA to ensure that the component is suitable for your use.

Standard Ratings

| Rated voltage (V) | Item | 6.3 | | | 10 | | | 16 | | | 25 | | | 35 | | | 50 | | | |
|-------------------|---------|------------------|------------------|----------------------------------|------------------|------------------|----------------------------------|------------------|------------------|----------------------------------|------------------|------------------|----------------------------------|------------------|------------------|----------------------------------|------------------|------------------|----------------------------------|----|
| | | Case φD×L(mm) | Casing symbol | Rated ripple current mAmps | Case φD×L(mm) | Casing symbol | Rated ripple current mAmps | Case φD×L(mm) | Casing symbol | Rated ripple current mAmps | Case φD×L(mm) | Casing symbol | Rated ripple current mAmps | Case φD×L(mm) | Casing symbol | Rated ripple current mAmps | Case φD×L(mm) | Casing symbol | Rated ripple current mAmps | |
| 0.33 | — | — | — | — | — | — | — | — | — | — | — | — | — | — | — | 4×5.8 | D61 | 3.2 | | |
| 0.47 | — | — | — | — | — | — | — | — | — | — | — | — | — | — | — | 4×5.8 | D61 | 5.0 | | |
| 1 | — | — | — | — | — | — | — | — | — | — | — | — | — | — | — | 4×5.8 | D61 | 10 | | |
| 2.2 | — | — | — | — | — | — | — | — | — | — | — | — | — | — | — | 4×5.8 | D61 | 16 | | |
| 3.3 | — | — | — | — | — | — | — | — | — | — | — | — | — | — | — | 4×5.8 | D61 | 17 | | |
| 4.7 | — | — | — | — | — | — | — | — | — | — | — | — | — | — | 4×5.8 | D61 | 16 | 5×5.8 | E61 | 23 |
| 10 | — | — | — | — | — | — | 4×5.8 | D61 | 28 | — | — | — | 5×5.8 | E61 | 28 | 6.3×5.8 | F61 | 35 | | |
| 22 | 4×5.8 | D61 | 26 | — | — | — | 5×5.8 | E61 | 39 | — | — | — | 6.3×5.8 | F61 | 55 | 6.3×7.7 | F80 | 58 | | |
| 33 | — | — | — | 5×5.8 | E61 | 43 | — | — | — | 6.3×5.8 | F61 | 60 | 6.3×7.7 | F80 | 57 | 8×10 | G10 | 91 | | |
| 47 | 5×5.8 | E61 | 46 | — | — | — | 6.3×5.8 | F61 | 70 | 6.3×7.7 | F80 | 65 | — | — | — | 8×10 | G10 | 100 | | |
| 100 | 6.3×5.8 | F61 | 71 | — | — | — | 6.3×7.7 | F80 | 81 | 8×10 | G10 | 130 | — | — | — | 10×10 | H10 | 160 | | |
| 220 | 6.3×7.7 | F80 | 101 | 8×10 | G10 | 160 | — | — | — | — | — | — | 10×10 | H10 | 220 | — | — | — | | |
| 330 | 8×10 | G10 | 230 | — | — | — | — | — | — | 10×10 | H10 | 238 | — | — | — | — | — | — | | |
| 470 | — | — | — | — | — | — | 10×10 | H10 | 340 | — | — | — | — | — | — | — | — | — | | |
| 1000 | 10×10 | H10 | 313 | — | — | — | — | — | — | — | — | — | — | — | — | — | — | — | | |

(Note) Rated ripple current : 105°C, 120Hz

Chip Type, 105°C Use, Low Impedance, Long Life Capacitors

| | | | | |
|-----------|-----|-------|--------------------|-----------------------|
| GREEN CAP | SMD | Low Z | 105°C 2000hours | Anti-cleaning solvent |
|-----------|-----|-------|--------------------|-----------------------|

- Compatible with surface mounting.
- Supplied with carrier taping.
- Guarantees 2000 hours at 105°C.
(6.3 to 50V 10.0L,10.5L:5000 hours)
(φ12.5x13.5L: 5000 hours)

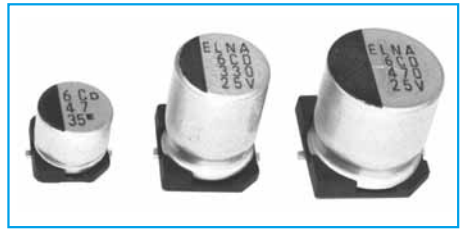
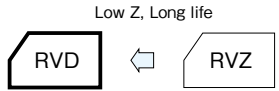

Marking color : Black print

Specifications

| Item | Performance | | | | | | | | | | | | | |
|---|--|---|------|------|------|------|------|------|------|------|---|---|--|--|
| Category temperature range (°C) | -55 to +105 | | | | | | | | | | | | | |
| Tolerance at rated capacitance (%) | ±20 (20°C,120Hz) | | | | | | | | | | | | | |
| Leakage current (μA) | Less than 0.01CV or 3 whichever is larger (after 2 minutes) C : Rated capacitance (μF) , V : Rated voltage (V) (20°C) | | | | | | | | | | | | | |
| Tangent of loss angle (tanδ) | Rated voltage (V) | 6.3 | 10 | 16 | 25 | 35 | 50 | 63 | 80 | 100 | | | | |
| | tanδ (max.) | 0.26 | 0.19 | 0.16 | 0.14 | 0.12 | 0.10 | 0.08 | 0.08 | 0.07 | | | | |
| Characteristics at high and low temperature | Impedance ratio (max.) | Rated voltage (V) | | | | | | | | | | | | |
| | | Z-25°C/Z+20°C | 2 | 2 | 2 | 2 | 2 | 2 | 2 | 2 | 2 | 2 | | |
| | | Z-40°C/Z+20°C | 3 | 3 | 3 | 3 | 3 | 3 | 3 | 3 | 3 | 3 | | |
| | | Z-55°C/Z+20°C | 8 | 4 | 4 | 3 | 3 | 3 | 3 | 3 | 3 | 3 | | |
| Endurance (105°C) | Test time | 2000 hours (6.3 to 50V 10.0L,10.5L,φ12.5x13.5L : 5000 hours) | | | | | | | | | | | | |
| | Leakage current | The initial specified value or less | | | | | | | | | | | | |
| | Percentage of capacitance change | Within ±30% of initial value | | | | | | | | | | | | |
| | Tangent of the loss angle | 200% or less of the initial specified value (6.3 to 50V 10.0L,10.5L,φ12.5x13.5L : 300% or less) | | | | | | | | | | | | |
| Shelf life (105°C) | Test time : 1000 hours ; other items are the same as those for the endurance. Voltage application treatment : According to JIS C5101-1 | | | | | | | | | | | | | |
| Applicable standards | JIS C 5101-1 1998, -18 1999(IEC 60384-1 1992, -18 1993) | | | | | | | | | | | | | |

Outline Drawing

Unit : mm

| φD | L | A | B | C | M | W | P | Casing symbol |
|------|----------|------|------|-----|---------|------------|-----|---------------|
| 4 | 5.8±0.3 | 4.3 | 4.3 | 2.0 | 0.4±0.2 | 0.5 to 0.8 | 1.0 | D61 |
| 5 | 5.8±0.3 | 5.3 | 5.3 | 2.3 | 0.4±0.2 | 0.5 to 0.8 | 1.5 | E61 |
| 6.3 | 5.8±0.3 | 6.6 | 6.6 | 2.7 | 0.4±0.2 | 0.5 to 0.8 | 2.0 | F61 |
| 6.3 | 7.7±0.3 | 6.6 | 6.6 | 2.7 | 0.4±0.2 | 0.5 to 0.8 | 2.0 | F80 |
| 8 | 6.5±0.3 | 8.4 | 8.4 | 3.4 | 0.4±0.2 | 0.5 to 0.8 | 2.3 | G68 |
| 8 | 10±0.5 | 8.4 | 8.4 | 3.0 | 0.4±0.2 | 0.7 to 1.1 | 3.1 | G10 |
| 8 | 10.5±0.5 | 8.4 | 8.4 | 3.0 | 0.4±0.2 | 0.7 to 1.1 | 3.1 | GA5 |
| 10 | 10±0.5 | 10.4 | 10.4 | 3.3 | 0.4±0.2 | 0.7 to 1.1 | 4.7 | H10 |
| 10 | 10.5±0.5 | 10.4 | 10.4 | 3.3 | 0.4±0.2 | 0.7 to 1.1 | 4.7 | HA5 |
| 12.5 | 13.5±0.5 | 13.0 | 13.0 | 4.9 | 0.7±0.3 | 1.0 to 1.4 | 4.6 | IE |

- Soldering conditions are described on page 13.
- Land pattern size are described on page 11.
- The taping specifications are described on page 14.

Coefficient of Frequency for Rated Ripple Current

| Frequency (Hz) | 50 | 120 | 1k | 10k·100k |
|-------------------|------|------|------|----------|
| Rated voltage (V) | 0.50 | 0.50 | 0.75 | 1 |
| 6.3 to 100 | 0.50 | 0.50 | 0.75 | 1 |

Part numbering system

φ 10X10.5L or less (16V100μF)

RVD — 16 V 101 M F61 U — □

Series code Rated voltage symbol Rated capacitance symbol Capacitance tolerance symbol Casing symbol Taping symbol

In the case of "for High Temperature Reflow" type, a series name is "RZB".

φ 12.5X13.5 (16V1000μF)

RVD — 16 V 102 M I E T — R5

Series code Rated voltage symbol Rated capacitance symbol Capacitance tolerance symbol Casing symbol Taping symbol

Standard Ratings

| Rated voltage (V) | Item | 6.3 | | | | 10 | | | | 16 | | | |
|-------------------|-----------|-----------|---------------|-----------|----------------------|-----------|---------------|-----------|----------------------|-----------|---------------|-----------|----------------------|
| | | Case | Casing symbol | Impedance | Rated ripple current | Case | Casing symbol | Impedance | Rated ripple current | Case | Casing symbol | Impedance | Rated ripple current |
| | | φD×L (mm) | | (Ω max.) | (mArms) | φD×L (mm) | | (Ω max.) | (mArms) | φD×L (mm) | | (Ω max.) | (mArms) |
| 10 | — | — | — | — | — | — | — | — | — | 4×5.8 | D61 | 1.35 | 90 |
| 22 | 4×5.8 | D61 | 1.35 | 90 | 4×5.8 | D61 | 1.35 | 90 | 4×5.8 | D61 | 1.35 | 90 | |
| 33 | — | — | — | — | 4×5.8 | D61 | 1.35 | 90 | 5×5.8 | E61 | 0.70 | 170 | |
| | — | — | — | — | 5×5.8 | E61 | 0.70 | 170 | — | — | — | — | |
| 47 | 4×5.8 | D61 | 1.35 | 90 | — | — | — | — | 5×5.8 | E61 | 0.70 | 170 | |
| | 5×5.8 | E61 | 0.70 | 170 | — | — | — | — | 6.3×5.8 | F61 | 0.36 | 250 | |
| 100 | 5×5.8 | E61 | 0.70 | 170 | — | — | — | — | 6.3×5.8 | F61 | 0.36 | 250 | |
| | 6.3×5.8 | F61 | 0.36 | 250 | — | — | — | — | — | — | — | — | |
| 220 | 6.3×5.8 | F61 | 0.36 | 250 | 6.3×7.7 | F80 | 0.30 | 300 | 6.3×7.7 | F80 | 0.30 | 300 | |
| | — | — | — | — | 8×6.5 | G68 | 0.30 | 300 | 8×6.5 | G68 | 0.30 | 300 | |
| 330 | 6.3×7.7 | F80 | 0.30 | 300 | 8×10 | G10 | 0.16 | 600 | 8×10 | G10 | 0.16 | 600 | |
| | 8×6.5 | G68 | 0.30 | 300 | — | — | — | — | — | — | — | — | |
| 470 | 8×10 | G10 | 0.16 | 600 | 8×10 | G10 | 0.16 | 600 | 8×10 | G10 | 0.16 | 600 | |
| 680 | — | — | — | — | 8×10 | G10 | 0.16 | 600 | 10×10 | H10 | 0.09 | 850 | |
| | — | — | — | — | — | — | — | — | 10×10.5 | HA5 | 0.08 | 850 | |
| 1000 | 8×10 | G10 | 0.16 | 600 | 10×10 | H10 | 0.09 | 850 | 12.5×13.5 | IE | 0.054 | 1160 | |
| | — | — | — | — | 10×10.5 | HA5 | 0.08 | 850 | — | — | — | — | |
| 1500 | 10×10 | H10 | 0.09 | 850 | 12.5×13.5 | IE | 0.054 | 1160 | 12.5×13.5 | IE | 0.054 | 1160 | |
| | 10×10.5 | HA5 | 0.08 | 850 | — | — | — | — | — | — | — | — | |
| 2200 | 12.5×13.5 | IE | 0.054 | 1160 | 12.5×13.5 | IE | 0.054 | 1160 | — | — | — | — | |

| Rated voltage (V) | Item | 25 | | | | 35 | | | | 50 | | | |
|-------------------|-----------|-----------|---------------|-----------|----------------------|-----------|---------------|-----------|----------------------|-----------|---------------|-----------|----------------------|
| | | Case | Casing symbol | Impedance | Rated ripple current | Case | Casing symbol | Impedance | Rated ripple current | Case | Casing symbol | Impedance | Rated ripple current |
| | | φD×L (mm) | | (Ω max.) | (mArms) | φD×L (mm) | | (Ω max.) | (mArms) | φD×L (mm) | | (Ω max.) | (mArms) |
| 4.7 | — | — | — | — | 4×5.8 | D61 | 1.35 | 90 | 4×5.8 | D61 | 2.7 | 60 | |
| 10 | 4×5.8 | D61 | 1.35 | 90 | 4×5.8 | D61 | 1.35 | 90 | 5×5.8 | E61 | 1.5 | 90 | |
| | — | — | — | — | 5×5.8 | E61 | 0.70 | 170 | 6.3×5.8 | F61 | 0.86 | 170 | |
| 22 | 5×5.8 | E61 | 0.70 | 170 | 5×5.8 | E61 | 0.70 | 170 | 6.3×5.8 | F61 | 0.86 | 170 | |
| 33 | 5×5.8 | E61 | 0.70 | 170 | 6.3×5.8 | F61 | 0.36 | 250 | 6.3×7.7 | F80 | 0.66 | 195 | |
| | 6.3×5.8 | F61 | 0.36 | 250 | | | | | 8×6.5 | G68 | 0.63 | 200 | |
| 47 | 6.3×5.8 | F61 | 0.36 | 250 | 6.3×5.8 | F61 | 0.36 | 250 | 6.3×7.7 | F80 | 0.66 | 195 | |
| | — | — | — | — | | | | | 8×6.5 | G68 | 0.63 | 200 | |
| 100 | 6.3×7.7 | F80 | 0.30 | 300 | 6.3×7.7 | F80 | 0.30 | 300 | 8×10 | G10 | 0.34 | 350 | |
| | 8×6.5 | G68 | 0.30 | 300 | 8×10 | G10 | 0.16 | 600 | 8×10.5 | GA5 | 0.32 | 350 | |
| 220 | 8×10 | G10 | 0.16 | 600 | 8×10 | G10 | 0.16 | 600 | 10×10 | H10 | 0.20 | 700 | |
| | — | — | — | — | | | | | 10×10.5 | HA5 | 0.18 | 700 | |
| 330 | 8×10 | G10 | 0.16 | 600 | 10×10 | H10 | 0.09 | 850 | 12.5×13.5 | IE | 0.12 | 900 | |
| | — | — | — | — | 10×10.5 | HA5 | 0.08 | 850 | | | | | |
| 470 | 10×10 | H10 | 0.09 | 850 | 12.5×13.5 | IE | 0.054 | 1160 | — | — | — | — | |
| | 10×10.5 | HA5 | 0.08 | 850 | | | | | — | — | — | — | |
| 680 | 12.5×13.5 | IE | 0.054 | 1160 | 12.5×13.5 | IE | 0.054 | 1160 | — | — | — | — | |
| 1000 | 12.5×13.5 | IE | 0.054 | 1160 | — | — | — | — | — | — | — | — | |

| Rated voltage (V) | Item | 63 | | | | 80 | | | | 100 | | | |
|-------------------|-----------|-----------|---------------|-----------|----------------------|-----------|---------------|-----------|----------------------|-----------|---------------|-----------|----------------------|
| | | Case | Casing symbol | Impedance | Rated ripple current | Case | Casing symbol | Impedance | Rated ripple current | Case | Casing symbol | Impedance | Rated ripple current |
| | | φD×L (mm) | | (Ω max.) | (mArms) | φD×L (mm) | | (Ω max.) | (mArms) | φD×L (mm) | | (Ω max.) | (mArms) |
| 4.7 | 5×5.8 | E61 | 3.0 | 50 | — | — | — | — | — | — | — | — | |
| 10 | 6.3×5.8 | F61 | 1.5 | 80 | 6.3×7.7 | F80 | 2.4 | 60 | — | — | — | — | |
| 22 | 6.3×7.7 | F80 | 1.2 | 120 | 8×10 | G10 | 0.90 | 130 | 8×10 | G10 | 1.30 | 130 | |
| 33 | 8×10 | G10 | 0.65 | 250 | 8×10 | G10 | 0.90 | 130 | 10×10 | H10 | 0.70 | 200 | |
| 47 | 8×10 | G10 | 0.65 | 250 | 10×10 | H10 | 0.50 | 200 | — | — | — | — | |
| 68 | 8×10 | G10 | 0.65 | 250 | — | — | — | — | — | — | — | — | |
| 100 | 10×10 | H10 | 0.35 | 400 | 12.5×13.5 | IE | 0.18 | 550 | — | — | — | — | |
| | 12.5×13.5 | IE | 0.16 | 600 | | | | | — | — | — | — | |
| 220 | 12.5×13.5 | IE | 0.16 | 600 | — | — | — | — | — | — | — | — | |

(Note) Rated ripple current : 105°C, 100kHz
Impedance : 20°C, 100kHz

NOTE : Design, Specifications are subject to change without notice.
It is recommended that you shall obtain technical specifications from ELNA to ensure that the component is suitable for your use.

Chip Type, 105°C Use, Low ESR, High CV Capacitors

- GREEN CAP
- SMD
- Low ESR
- 105°C 2000hours
- Anti-cleaning solvent

- Compatible with surface mounting.
- Supplied with carrier taping.
- Guaranteed 2000 hours at 105°C.

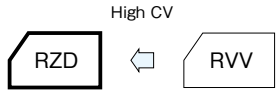

Marking color : Black print

Specifications

| Item | Performance | | | | | | |
|---|--|---|------|------|------|------|----|
| Category temperature range (°C) | -55 to +105 | | | | | | |
| Tolerance at rated capacitance (%) | ±20 (20°C, 120Hz) | | | | | | |
| Leakage current (µA) | Less than 0.01CV or 3 whichever is larger (after 2 minutes) C : Rated capacitance (µF) , V : Rated voltage (V) (20°C) | | | | | | |
| Tangent of loss angle (tanδ) | Rated voltage (V) | 6.3 | 10 | 16 | 25 | 35 | |
| | tanδ (max.) | 0.26 | 0.19 | 0.16 | 0.14 | 0.12 | |
| Characteristics at high and low temperature | Impedance ratio (max.) | Rated voltage (V) | 6.3 | 10 | 16 | 25 | 35 |
| | | Z-25°C/Z+20°C | 2 | 2 | 2 | 2 | 2 |
| | | Z-40°C/Z+20°C | 3 | 3 | 3 | 3 | 3 |
| | | Z-55°C/Z+20°C | 8 | 4 | 4 | 3 | 3 |
| Endurance (105°C) | Test time | 2000 hours | | | | | |
| | Leakage current | The initial specified value or less | | | | | |
| | Percentage of capacitance change | Within ±30% of initial value | | | | | |
| | Tangent of the loss angle | 200% or less of the initial specified value | | | | | |
| Shelf life (105°C) | Test time : 1000 hours ; other items are the same as those for the endurance. Voltage application treatment : According to JIS C5101-1 | | | | | | |
| Applicable standards | JIS C 5101-1 1998, -18 1999(IEC 60384-1 1992, -18 1993) | | | | | | |

Outline Drawing

Unit : mm

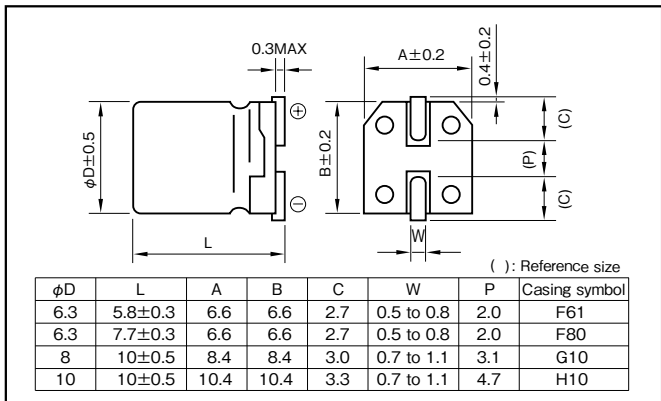

- Soldering conditions are described on page 13.
- Land pattern size are described on page 11.
- The taping specifications are described on page 14.

Coefficient of Frequency for Rated Ripple Current

| Frequency (Hz) | 50 | 120 | 1k | 10k·100k |
|-------------------|------|------|------|----------|
| Rated voltage (V) | | | | |
| 6.3 to 35 | 0.50 | 0.50 | 0.75 | 1 |

Part numbering system (example : 35V150µF)

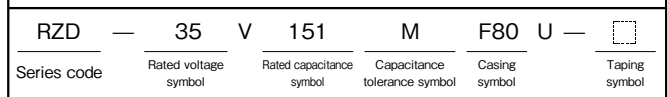

Standard Ratings

| Rated voltage (V) Item Rated capacitance (µF) | 6.3 | | | | 10 | | | | 16 | | | |
|---|-----------|---------------|----------|----------------------|-----------|---------------|----------|----------------------|-----------|---------------|----------|----------------------|
| | Case | Casing symbol | ESR | Rated ripple current | Case | Casing symbol | ESR | Rated ripple current | Case | Casing symbol | ESR | Rated ripple current |
| | φD×L (mm) | | (Ω max.) | (mAmps) | φD×L (mm) | | (Ω max.) | (mAmps) | φD×L (mm) | | (Ω max.) | (mAmps) |
| 150 | — | — | — | — | — | — | — | — | 6.3×5.8 | F61 | 0.26 | 300 |
| 220 | — | — | — | — | 6.3×5.8 | F61 | 0.26 | 300 | 6.3×5.8 | F61 | 0.26 | 300 |
| 330 | 6.3×5.8 | F61 | 0.26 | 300 | 6.3×7.7 | F80 | 0.16 | 600 | 6.3×7.7 | F80 | 0.16 | 600 |
| 470 | 6.3×7.7 | F80 | 0.16 | 600 | 6.3×7.7 | F80 | 0.16 | 600 | — | — | — | — |
| 680 | 6.3×7.7 | F80 | 0.16 | 600 | — | — | — | — | 8×10 | G10 | 0.08 | 850 |
| 1000 | — | — | — | — | 8×10 | G10 | 0.08 | 850 | 10×10 | H10 | 0.06 | 1190 |
| 1500 | 8×10 | G10 | 0.08 | 850 | 10×10 | H10 | 0.06 | 1190 | — | — | — | — |
| 2200 | 10×10 | H10 | 0.06 | 1190 | — | — | — | — | — | — | — | — |

| Rated voltage (V) Item Rated capacitance (µF) | 25 | | | | 35 | | | |
|---|-----------|---------------|----------|----------------------|-----------|---------------|----------|----------------------|
| | Case | Casing symbol | ESR | Rated ripple current | Case | Casing symbol | ESR | Rated ripple current |
| | φD×L (mm) | | (Ω max.) | (mAmps) | φD×L (mm) | | (Ω max.) | (mAmps) |
| 100 | — | — | — | — | 6.3×5.8 | F61 | 0.26 | 300 |
| 150 | 6.3×5.8 | F61 | 0.26 | 300 | 6.3×7.7 | F80 | 0.16 | 600 |
| 220 | 6.3×7.7 | F80 | 0.16 | 600 | — | — | — | — |
| 330 | — | — | — | — | 8×10 | G10 | 0.08 | 850 |
| 470 | 8×10 | G10 | 0.08 | 850 | — | — | — | — |
| 560 | — | — | — | — | 10×10 | H10 | 0.06 | 1190 |
| 820 | 10×10 | H10 | 0.06 | 1190 | — | — | — | — |

(Note) Rated ripple current : 105°C , 100kHz
 ESR : 20°C , 100kHz

Chip Type, 105°C Use, Low Impedance Capacitors

- GREEN CAP
- SMD
- Low Z
- 105°C 2000hours
- Anti-cleaning solvent

- Compatible with surface mounting.
- Supplied with carrier taping.
- Guarantees 2000 hours at 105°C.

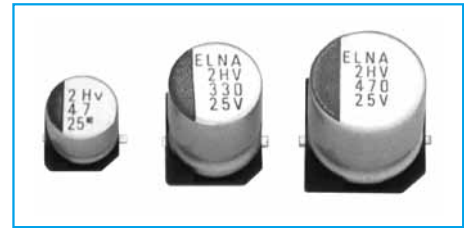
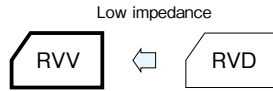

Marking color : Black print

Specifications

| Item | Performance | | | | | | |
|---|--|---|------|------|------|------|---|
| Category temperature range (°C) | -55 to +105 | | | | | | |
| Tolerance at rated capacitance (%) | ±20 (20°C, 120Hz) | | | | | | |
| Leakage current (µA) | Less than 0.01CV or 3 whichever is larger (after 2 minutes) C : Rated capacitance (µF) , V : Rated voltage (V) (20°C) | | | | | | |
| Tangent of loss angle (tanδ) | Rated voltage (V) | 6.3 | 10 | 16 | 25 | 35 | |
| | tanδ (max.) | 0.26 | 0.19 | 0.16 | 0.14 | 0.12 | |
| Characteristics at high and low temperature | Rated voltage (V) | 6.3 | 10 | 16 | 25 | 35 | |
| | Impedance ratio (max.) | Z-25°C/Z+20°C | 2 | 2 | 2 | 2 | 2 |
| | | Z-40°C/Z+20°C | 3 | 3 | 3 | 3 | 3 |
| | | Z-55°C/Z+20°C | 8 | 4 | 4 | 3 | 3 |
| Endurance (105°C) | Test time | 2000 hours | | | | | |
| | Leakage current | The initial specified value or less | | | | | |
| | Percentage of capacitance change | Within ±30% of initial value | | | | | |
| | Tangent of the loss angle | 200% or less of initial specified value | | | | | |
| Shelf life (105°C) | Test time : 1000 hours ; other items are the same as those for the endurance. Voltage application treatment : According to JIS C5101-1 | | | | | | |
| Applicable standards | JIS C 5101-1 1998, -18 1999(IEC 60384-1 1992, -18 1993) | | | | | | |

Outline Drawing

Unit : mm

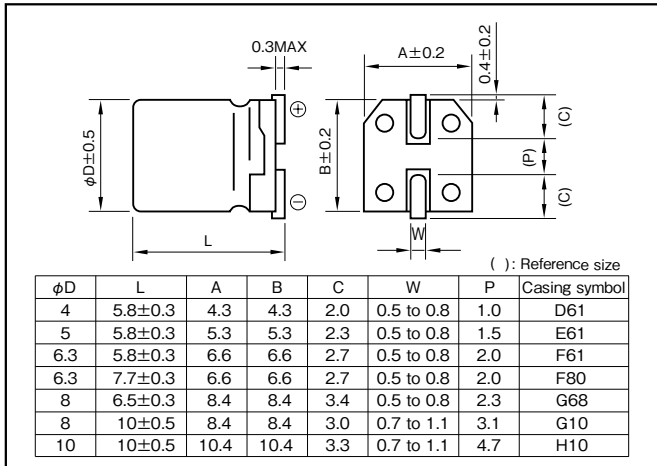

- Soldering conditions are described on page 13.
- Land pattern size are described on page 11.
- The taping specifications are described on page 14.

Coefficient of Frequency for Rated Ripple Current

| Frequency (Hz) | 50 | 120 | 1k | 10k·100k |
|-------------------|-----|-----|------|----------|
| Rated voltage (V) | | | | |
| 6.3 to 35 | 0.5 | 0.5 | 0.75 | 1 |

Part numbering system (example : 16V100µF)

| | | | | | | | | | |
|-------------|---|----------------------|---|--------------------------|------------------------------|---------------|---|---|---------------|
| RVV | — | 16 | V | 101 | M | F61 | U | — | () |
| Series code | | Rated voltage symbol | | Rated capacitance symbol | Capacitance tolerance symbol | Casing symbol | | | Taping symbol |

NOTE : Design, Specifications are subject to change without notice. It is recommended that you shall obtain technical specifications from ELNA to ensure that the component is suitable for your use.

Standard Ratings

| Rated voltage (V) | Item | 6.3 | | | | 10 | | | | 16 | | | |
|-------------------|---------|-----------|---------------|-----------|----------------------|-----------|---------------|-----------|----------------------|-----------|---------------|-----------|----------------------|
| | | Case | Casing symbol | Impedance | Rated ripple current | Case | Casing symbol | Impedance | Rated ripple current | Case | Casing symbol | Impedance | Rated ripple current |
| | | φD×L (mm) | | (Ω max.) | (mArms) | φD×L (mm) | | (Ω max.) | (mArms) | φD×L (mm) | | (Ω max.) | (mArms) |
| 10 | — | — | — | — | — | — | — | — | — | 4×5.8 | D61 | 0.85 | 160 |
| 22 | 4×5.8 | D61 | 0.85 | 160 | 4×5.8 | D61 | 0.85 | 160 | 4×5.8 | D61 | 0.85 | 160 | |
| | | | | | | | | | 5×5.8 | E61 | 0.36 | 240 | |
| 33 | — | — | — | — | 4×5.8 | D61 | 0.85 | 160 | — | — | — | — | |
| | | | | | 5×5.8 | E61 | 0.36 | 240 | — | — | — | — | |
| 47 | 4×5.8 | D61 | 0.85 | 160 | — | — | — | — | 5×5.8 | E61 | 0.36 | 240 | |
| | 5×5.8 | E61 | 0.36 | 240 | — | — | — | — | 6.3×5.8 | F61 | 0.26 | 300 | |
| 100 | 5×5.8 | E61 | 0.36 | 240 | — | — | — | — | 6.3×5.8 | F61 | 0.26 | 300 | |
| | 6.3×5.8 | F61 | 0.26 | 300 | — | — | — | — | 6.3×7.7 | F80 | 0.16 | 600 | |
| 220 | 6.3×5.8 | F61 | 0.26 | 300 | 6.3×7.7 | F80 | 0.16 | 600 | 6.3×7.7 | F80 | 0.16 | 600 | |
| | | | | | 8×6.5 | G68 | 0.18 | 500 | 8×6.5 | G68 | 0.18 | 500 | |
| 330 | 6.3×7.7 | F80 | 0.16 | 600 | 8×10 | G10 | 0.09 | 850 | 8×10 | G10 | 0.09 | 850 | |
| | 8×6.5 | G68 | 0.18 | 500 | — | — | — | — | — | — | — | — | |
| 470 | 8×10 | G10 | 0.09 | 850 | 8×10 | G10 | 0.09 | 850 | 8×10 | G10 | 0.09 | 850 | |
| 680 | — | — | — | — | 8×10 | G10 | 0.09 | 850 | 10×10 | H10 | 0.07 | 1190 | |
| 1000 | 8×10 | G10 | 0.09 | 850 | 10×10 | H10 | 0.07 | 1190 | — | — | — | — | |
| 1500 | 10×10 | H10 | 0.07 | 1190 | — | — | — | — | — | — | — | — | |

| Rated voltage (V) | Item | 25 | | | | 35 | | | |
|-------------------|---------|-----------|---------------|-----------|----------------------|-----------|---------------|-----------|----------------------|
| | | Case | Casing symbol | Impedance | Rated ripple current | Case | Casing symbol | Impedance | Rated ripple current |
| | | φD×L (mm) | | (Ω max.) | (mArms) | φD×L (mm) | | (Ω max.) | (mArms) |
| 4.7 | — | — | — | — | 4×5.8 | D61 | 0.85 | 160 | |
| 10 | 4×5.8 | D61 | 0.85 | 160 | 4×5.8 | D61 | 0.85 | 160 | |
| | | | | | 5×5.8 | E61 | 0.36 | 240 | |
| 22 | 5×5.8 | E61 | 0.36 | 240 | 5×5.8 | E61 | 0.36 | 240 | |
| 33 | 5×5.8 | E61 | 0.36 | 240 | 6.3×5.8 | F61 | 0.26 | 300 | |
| | 6.3×5.8 | F61 | 0.26 | 300 | — | — | — | — | |
| 47 | 6.3×5.8 | F61 | 0.26 | 300 | 6.3×5.8 | F61 | 0.26 | 300 | |
| 100 | 6.3×7.7 | F80 | 0.16 | 600 | 6.3×7.7 | F80 | 0.16 | 600 | |
| | 8×6.5 | G68 | 0.18 | 500 | 8×10 | G10 | 0.09 | 850 | |
| 220 | 8×10 | G10 | 0.09 | 850 | 8×10 | G10 | 0.09 | 850 | |
| 330 | 8×10 | G10 | 0.09 | 850 | 10×10 | H10 | 0.07 | 1190 | |
| 470 | 10×10 | H10 | 0.07 | 1190 | — | — | — | — | |

(Note) Rated ripple current : 105°C , 100kHz
Impedance : 20°C , 100kHz

Chip Type, 105°C Use, Low Impedance Capacitors

GREEN CAP

SMD

Low z

105°C
2000hours

Anti-
cleaning
solvent

- Compatible with surface mounting.
- Supplied with carrier taping.
- Guarantees 2000 hours at 105°C.
($\phi 8 \times 6.5L$ or less : 1000hours)
($\phi 12.5 \times 13.5L$: 5000hours)

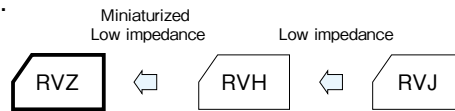

Marking color : Black print ($\phi 4 \times 5.3L - \phi 8 \times 6.5L, \phi 12.5 \times 13.5L$)
: White print on a brown sleeve ($\phi 8 \times 10L - \phi 10 \times 10.5L$)

Specifications

| Item | Performance | | | | | | |
|---|--|---|------|------|------|------|---|
| Category temperature range (°C) | -55 to +105 | | | | | | |
| Tolerance at rated capacitance (%) | ±20 (20°C, 120Hz) | | | | | | |
| Leakage current (µA) | Less than 0.01CV or 3 whichever is larger (after 2 minutes) C : Rated capacitance (µF) ; V : Rated voltage (V) (20°C) | | | | | | |
| Tangent of loss angle (tanδ) | Rated voltage (V) | 6.3 | 10 | 16 | 25 | 35 | |
| | tanδ (max.) | 0.28 | 0.24 | 0.20 | 0.16 | 0.14 | |
| Characteristics at high and low temperature | Rated voltage (V) | 6.3 | 10 | 16 | 25 | 35 | |
| | Impedance ratio (max.) | Z-25°C/Z+20°C | 4 | 3 | 2 | 2 | 2 |
| | | Z-55°C/Z+20°C | 8 | 5 | 4 | 3 | 3 |
| 0.02 is added to every 1000µF increase over 1000µF. (120Hz) | | | | | | | |
| Endurance (105°C) (Applied ripple current) | Test time | 1000 hours ($\phi 8 \times 6.5L$ or less) 2000 hours ($\phi 8 \times 10L$ to $\phi 10 \times 10.5L$) 5000 hours ($\phi 12.5 \times 13.5L$) | | | | | |
| | Leakage current | The initial specified value or less | | | | | |
| | Percentage of capacitance change | Within ±25% of initial value | | | | | |
| | Tangent of the loss angle | 200% or less of initial specified value | | | | | |
| Shelf life (105°C) | Test time : 1000 hours ; other items are the same as those for the endurance. Voltage application treatment : According to JIS C5101-1 | | | | | | |
| Applicable standards | JIS C5101-1 1998, -18 1999 (IEC 60384-1 1992, -18 1993) | | | | | | |

Outline Drawing

Unit : mm

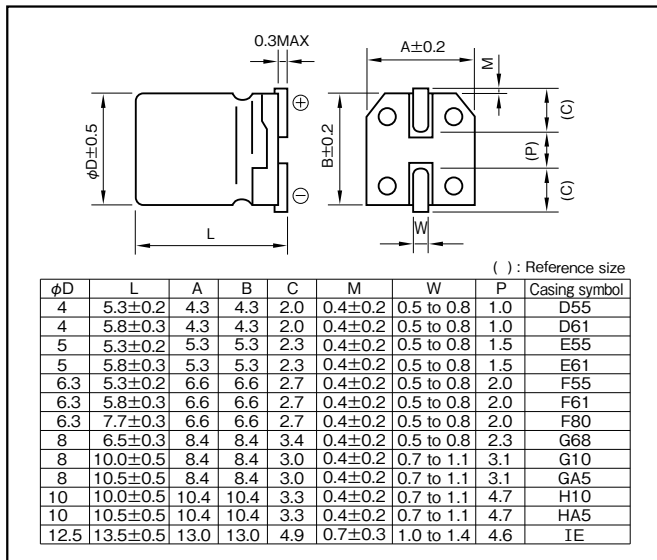

- Soldering conditions are described on page 13.
- Land pattern size are described on page 11.
- The taping specifications are described on page 14.

Coefficient of Frequency for Rated Ripple Current

| Frequency (Hz) | 120 | 1k | 10k | 100k | |
|-------------------|-----------|------|------|------|---|
| Rated voltage (V) | 6.3 to 35 | 0.50 | 0.75 | 0.90 | 1 |

Part numbering system

φ 10 × 10.5L or less 6.3V1500µF

| | | | | | | | | | |
|-------------|---|----------------------|---|--------------------------|------------------------------|---------------|---|---|---------------|
| RVZ | — | 6 | V | 152 | M | HA5 | U | — | □ |
| Series code | | Rated voltage symbol | | Rated capacitance symbol | Capacitance tolerance symbol | Casing symbol | | | Taping symbol |

In the case of "for High Temperature Reflow" type, a series name is "RZA".

φ 12.5 × 13.5L 6.3V2700µF

| | | | | | | | | | |
|-------------|---|----------------------|---|--------------------------|------------------------------|---------------|---|---|---------------|
| RVZ | — | 6 | V | 272 | M | IE | T | — | R5 |
| Series code | | Rated voltage symbol | | Rated capacitance symbol | Capacitance tolerance symbol | Casing symbol | | | Taping symbol |

Standard Ratings

| Rated voltage (V) Rated capacitance (μF) Item | 6.3 | | | | 10 | | | | 16 | | | | 25 | | | | 35 | | | |
|---|-----------|---------------|-----------|----------------------|-----------|---------------|-----------|----------------------|-----------|---------------|-----------|----------------------|-----------|---------------|-----------|----------------------|-----------|---------------|-----------|----------------------|
| | Case | Casing symbol | Impedance | Rated ripple current | Case | Casing symbol | Impedance | Rated ripple current | Case | Casing symbol | Impedance | Rated ripple current | Case | Casing symbol | Impedance | Rated ripple current | Case | Casing symbol | Impedance | Rated ripple current |
| | φDXL (mm) | | (Ω) | (mAmps) | φDXL (mm) | | (Ω) | (mAmps) | φDXL (mm) | | (Ω) | (mAmps) | φDXL (mm) | | (Ω) | (mAmps) | φDXL (mm) | | (Ω) | (mAmps) |
| 4.7 | — | — | — | — | — | — | — | — | — | — | — | — | 4×5.3 | D55 | 3.20 | 65 | 4×5.3 | D55 | 3.20 | 65 |
| 10 | — | — | — | — | 4×5.3 | D55 | 3.20 | 65 | 4×5.3 | D55 | 3.20 | 65 | 4×5.8 | D61 | 1.80 | 80 | 5×5.3 | E55 | 1.50 | 110 |
| | — | — | — | — | — | — | — | — | — | — | — | — | 5×5.3 | E55 | 1.50 | 110 | 5×5.8 | E61 | 0.76 | 150 |
| 15 | — | — | — | — | — | — | — | — | 4×5.8 | D61 | 1.80 | 80 | 5×5.8 | E61 | 0.76 | 150 | 5×5.8 | E61 | 0.76 | 150 |
| 22 | 4×5.3 | D55 | 3.20 | 65 | 4×5.8 | D61 | 1.80 | 80 | 5×5.3 | E55 | 1.50 | 110 | 5×5.8 | E61 | 0.76 | 150 | 6.3×5.3 | F55 | 0.85 | 170 |
| | 4×5.8 | D61 | 1.80 | 80 | 5×5.3 | E55 | 1.50 | 110 | 5×5.8 | E61 | 0.76 | 150 | 6.3×5.3 | F55 | 0.85 | 170 | 6.3×5.3 | F55 | 0.85 | 170 |
| 33 | 5×5.3 | E55 | 1.50 | 110 | 5×5.3 | E55 | 1.50 | 110 | 6.3×5.3 | F55 | 0.85 | 170 | 6.3×5.3 | F55 | 0.85 | 170 | 6.3×5.3 | F55 | 0.85 | 170 |
| | 5×5.8 | E61 | 0.76 | 150 | 5×5.8 | E61 | 0.76 | 150 | 6.3×5.8 | F61 | 0.44 | 230 | 6.3×5.8 | F61 | 0.44 | 230 | 6.3×5.8 | F61 | 0.44 | 230 |
| 47 | 5×5.3 | E55 | 1.50 | 110 | 6.3×5.3 | F55 | 0.85 | 170 | 6.3×5.3 | F55 | 0.85 | 170 | 6.3×5.3 | F55 | 0.85 | 170 | 6.3×5.8 | F61 | 0.44 | 230 |
| | 5×5.8 | E61 | 0.76 | 150 | 6.3×5.8 | F61 | 0.44 | 230 | 6.3×5.8 | F61 | 0.44 | 230 | 6.3×5.8 | F61 | 0.44 | 230 | 6.3×7.7 | F80 | 0.34 | 280 |
| 68 | 6.3×5.8 | F61 | 0.44 | 230 | 6.3×5.8 | F61 | 0.44 | 230 | 6.3×5.8 | F61 | 0.44 | 230 | 6.3×5.8 | F61 | 0.44 | 230 | 8×6.5 | G68 | 0.34 | 280 |
| | 6.3×5.3 | F55 | 0.85 | 170 | 6.3×5.3 | F55 | 0.85 | 170 | 6.3×5.3 | F55 | 0.85 | 170 | 6.3×7.7 | F80 | 0.34 | 280 | 8×6.5 | G68 | 0.34 | 280 |
| 100 | 6.3×5.8 | F61 | 0.44 | 230 | 6.3×5.8 | F61 | 0.44 | 230 | 6.3×5.8 | F61 | 0.44 | 230 | 8×6.5 | G68 | 0.34 | 280 | 8×10.5 | GA5 | 0.17 | 450 |
| | 6.3×5.3 | F55 | 0.85 | 170 | 6.3×5.3 | F55 | 0.85 | 170 | 6.3×7.7 | F80 | 0.34 | 280 | 8×10.5 | GA5 | 0.17 | 450 | 8×10.5 | GA5 | 0.17 | 450 |
| 150 | 6.3×5.8 | F61 | 0.44 | 230 | 6.3×5.8 | F61 | 0.44 | 230 | 6.3×7.7 | F80 | 0.34 | 280 | 8×10.5 | GA5 | 0.17 | 450 | 10×10.5 | HA5 | 0.09 | 670 |
| | 6.3×5.8 | F61 | 0.44 | 230 | 6.3×5.8 | F61 | 0.44 | 230 | 8×6.5 | G68 | 0.34 | 280 | 8×10.5 | GA5 | 0.17 | 450 | 10×10.5 | HA5 | 0.09 | 670 |
| 220 | 6.3×5.8 | F61 | 0.44 | 230 | 6.3×7.7 | F80 | 0.34 | 280 | 6.3×7.7 | F80 | 0.34 | 280 | 8×10.5 | GA5 | 0.17 | 450 | 8×10.5 | GA5 | 0.17 | 450 |
| | 6.3×7.7 | F80 | 0.34 | 280 | 8×6.5 | G68 | 0.34 | 280 | 8×10 | G10 | 0.20 | 450 | 8×10.5 | GA5 | 0.17 | 450 | 8×10.5 | GA5 | 0.17 | 450 |
| 330 | 6.3×7.7 | F80 | 0.34 | 280 | 8×10.5 | GA5 | 0.17 | 450 | 8×10.5 | GA5 | 0.17 | 450 | 8×10.5 | GA5 | 0.17 | 450 | 10×10.5 | HA5 | 0.09 | 670 |
| | 8×6.5 | G68 | 0.34 | 280 | 10×10 | H10 | 0.10 | 670 | 10×10 | H10 | 0.10 | 670 | 10×10 | H10 | 0.10 | 670 | 10×10.5 | HA5 | 0.09 | 670 |
| 470 | 8×10.5 | GA5 | 0.17 | 450 | 8×10.5 | GA5 | 0.17 | 450 | 8×10.5 | GA5 | 0.17 | 450 | 10×10.5 | HA5 | 0.09 | 670 | 12.5×13.5 | IE | 0.06 | 1100 |
| | 10×10 | H10 | 0.10 | 670 | 10×10 | H10 | 0.10 | 670 | 10×10 | H10 | 0.10 | 670 | 10×10.5 | HA5 | 0.09 | 670 | 12.5×13.5 | IE | 0.06 | 1100 |
| 680 | 8×10.5 | GA5 | 0.17 | 450 | 10×10.5 | HA5 | 0.09 | 670 | 10×10.5 | HA5 | 0.09 | 670 | 12.5×13.5 | IE | 0.06 | 1100 | 12.5×13.5 | IE | 0.06 | 1100 |
| 1000 | 8×10.5 | GA5 | 0.17 | 450 | 10×10.5 | HA5 | 0.09 | 670 | 12.5×13.5 | IE | 0.06 | 1100 | 12.5×13.5 | IE | 0.06 | 1100 | — | — | — | — |
| | 10×10 | H10 | 0.10 | 670 | 10×10.5 | HA5 | 0.09 | 670 | 12.5×13.5 | IE | 0.06 | 1100 | 12.5×13.5 | IE | 0.06 | 1100 | — | — | — | — |
| 1500 | 10×10.5 | HA5 | 0.09 | 670 | 12.5×13.5 | IE | 0.06 | 1100 | 12.5×13.5 | IE | 0.06 | 1100 | — | — | — | — | — | — | — | — |
| 2200 | 12.5×13.5 | IE | 0.06 | 1100 | 12.5×13.5 | IE | 0.06 | 1100 | — | — | — | — | — | — | — | — | — | — | — | — |
| 2700 | 12.5×13.5 | IE | 0.06 | 1100 | — | — | — | — | — | — | — | — | — | — | — | — | — | — | — | — |

CHIP ALUMINUM

(Note) Rated ripple current : 105°C, 100kHz ; Impedance : 20°C, 100kHz

Chip Type, 125°C Use, High CV, Long Life Capacitors

GREEN CAP

SMD

Low ESR

125°C
4000hours

Anti-cleaning solvent

- Compatible with surface mounting.
- Supplied with carrier taping.
- Guaranteed 4000 hours at 125°C.
($\phi 6.3$: 2000 hours)

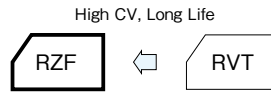

Marking color : Black print

Specifications

| Item | Performance | | | | |
|---|--|---|------|------|------|
| Category temperature range (°C) | -40 to +125 | | | | |
| Tolerance at rated capacitance (%) | ±20 (20°C, 120Hz) | | | | |
| Leakage current (µA) | Less than 0.01CV or 3 whichever is larger (after 2 minutes) C : Rated capacitance (µF) ; V : Rated voltage (V) (20°C) | | | | |
| Tangent of loss angle (tanδ) | Rated voltage (V) | 10 | 16 | 25 | 35 |
| | tanδ (max.) | 0.24 | 0.20 | 0.16 | 0.14 |
| Characteristics at high and low temperature | Impedance ratio (max.) | Z-25°C/Z+20°C | 3 | 2 | 2 |
| | | Z-40°C/Z+20°C | 6 | 4 | 4 |
| | (120Hz) | | | | |
| Endurance (125°C) | Test time | 4000 hours ($\phi 6.3$: 2000 hours) | | | |
| | Leakage current | The initial specified value or less | | | |
| | Percentage of capacitance change | Within ±30% of initial value | | | |
| | Tangent of the loss angle | 300% or less of the initial specified value | | | |
| Shelf life (125°C) | Test time : 1000 hours ; other items are the same as those for the endurance. Voltage application treatment : According to JIS C5101-1 | | | | |
| Applicable standards | JIS C5101-1 1998, -18 1999 (IEC 60384-1 1992, -18 1993) | | | | |

Outline Drawing

Unit : mm

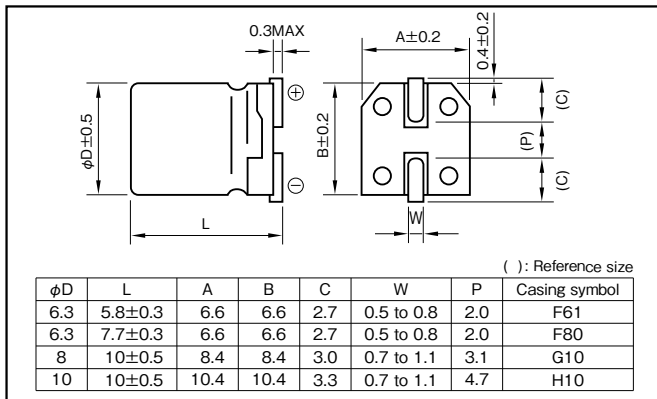

- Soldering conditions are described on page 13.
- Land pattern size are described on page 11.
- The taping specifications are described on page 14.

Coefficient of Frequency for Rated Ripple Current

| Frequency (Hz) | 120 | 1k | 10k | 100k |
|------------------|------|------|------|------|
| Rated voltage(V) | 120 | 1k | 10k | 100k |
| 10 to 35 | 0.77 | 0.88 | 0.96 | 1 |

Part numbering system (example : 35V100µF)

| | | | | | | | | | |
|-------------|---|----------------------|---|--------------------------|------------------------------|---------------|---|---|---------------|
| RZF | — | 35 | V | 101 | M | F80 | U | — | □ |
| Series code | | Rated voltage symbol | | Rated capacitance symbol | Capacitance tolerance symbol | Casing symbol | | | Taping symbol |

Standard Ratings

| Rated voltage (V) Rated capacitance (μF) Item | 10 | | | | 16 | | | | 25 | | | |
|---|-----------|-------------|-------|----------------------|-----------|-------------|-------|----------------------|-----------|-------------|-------|----------------------|
| | Case | ESR (Ωmax.) | | Rated ripple current | Case | ESR (Ωmax.) | | Rated ripple current | Case | ESR (Ωmax.) | | Rated ripple current |
| | φD×L (mm) | 20°C | -40°C | (mA _{rms}) | φD×L (mm) | 20°C | -40°C | (mA _{rms}) | φD×L (mm) | 20°C | -40°C | (mA _{rms}) |
| 47 | — | — | — | — | 6.3×5.8 | 1.2 | 22 | 110 | 6.3×5.8 | 1.2 | 22 | 110 |
| 100 | 6.3×5.8 | 1.2 | 22 | 110 | 6.3×5.8 | 1.2 | 22 | 110 | 6.3×7.7 | 0.60 | 12 | 220 |
| 220 | 6.3×7.7 | 0.60 | 12 | 220 | 6.3×7.7 | 0.60 | 12 | 220 | 8×10 | 0.30 | 5.5 | 296 |
| 330 | 8×10 | 0.30 | 5.5 | 296 | 8×10 | 0.30 | 5.5 | 296 | 10×10 | 0.20 | 3.6 | 440 |
| 470 | 8×10 | 0.30 | 5.5 | 296 | 10×10 | 0.20 | 3.6 | 440 | — | — | — | — |
| 680 | 10×10 | 0.20 | 3.6 | 440 | 10×10 | 0.20 | 3.6 | 440 | — | — | — | — |

| Rated voltage (V) Rated capacitance (μF) Item | 35 | | | |
|---|-----------|-------------|-------|----------------------|
| | Case | ESR (Ωmax.) | | Rated ripple current |
| | φD×L (mm) | 20°C | -40°C | (mA _{rms}) |
| 47 | 6.3×5.8 | 1.2 | 22 | 110 |
| 100 | 6.3×7.7 | 0.60 | 12 | 220 |
| 220 | 8×10 | 0.30 | 5.5 | 296 |
| 330 | 10×10 | 0.20 | 3.6 | 440 |

(Note) Rated ripple current : 125°C , 100kHz
ESR : 100kHz

Chip Type, 125°C Use, High CV, Long Life Capacitors

GREEN CAP SMD Low ESR 125°C 2000hours Anti-cleaning solvent

- Compatible with surface mounting.
- Supplied with carrier taping.
- Guaranteed 2000 hours at 125°C.

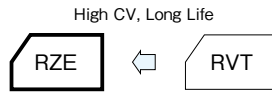

Marking color : Black print

Specifications

| Item | Performance | | |
|---|--|---|---|
| Category temperature range (°C) | -40 to +125 | | |
| Tolerance at rated capacitance (%) | ±20 (20°C, 120Hz) | | |
| Leakage current (µA) | Less than 0.01CV or 3 whichever is larger (after 2 minutes) C : Rated capacitance (µF) ; V : Rated voltage (V) (20°C) | | |
| Tangent of loss angle (tanδ) | Rated voltage (V) | 35 | |
| | tanδ (max.) | 0.16 | |
| (20°C, 120Hz) | | | |
| Characteristics at high and low temperature | Rated voltage (V) | 35 | |
| | Impedance Ratio (max.) | Z-25°C/Z+20°C | 2 |
| | | Z-40°C/Z+20°C | 3 |
| (120Hz) | | | |
| Endurance (125°C) | Test time | 2000 hours | |
| | Leakage current | The initial specified value or less | |
| | Percentage of capacitance change | Within ±30% of initial value | |
| | Tangent of the loss angle | 300% or less of the initial specified value | |
| Shelf life (125°C) | Test time : 1000 hours ; other items are the same as those for the endurance. Voltage application treatment : According to JIS C5101-1 | | |
| Applicable standards | JIS C5101-1 1998, -18 1999 (IEC 60384-1 1992, -18 1993) | | |

Outline Drawing

Unit : mm

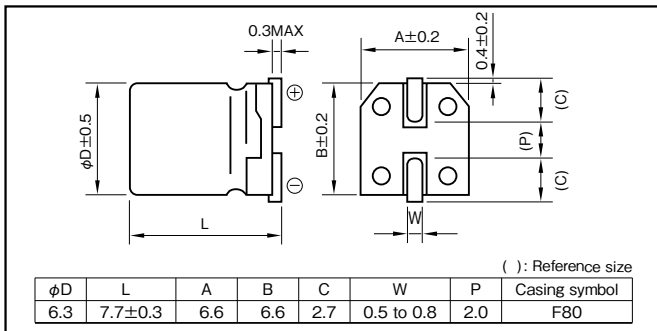

- Soldering conditions are described on page 13.
- Land pattern size are described on page 11.
- The taping specifications are described on page 14.

Coefficient of Frequency for Rated Ripple Current

| Frequency (Hz) | 120 | 1k | 10k | 100k |
|------------------|------|------|------|------|
| Rated voltage(V) | 120 | 1k | 10k | 100k |
| 35 | 0.77 | 0.88 | 0.96 | 1 |

Part numbering system (example : 35V47µF)

| | | | | | | | | | |
|-------------|---|----------------------|---|--------------------------|------------------------------|---------------|---|---|---------------|
| RZE | — | 35 | V | 470 | M | F80 | U | — | □ |
| Series code | | Rated voltage symbol | | Rated capacitance symbol | Capacitance tolerance symbol | Casing symbol | | | Taping symbol |

Standard Ratings

| Rated voltage (V) | Item | 35 | | | | Rated ripple current (mA rms) |
|-------------------|---------|------|--------------|-------|-----------------------|-------------------------------|
| | | Case | ESR (Ω max.) | | | |
| | | | 20°C | -40°C | After Endurance -40°C | |
| 47 | 6.3×7.7 | 0.30 | 3 | 6 | 197 | |
| 100 | 6.3×7.7 | 0.30 | 3 | 6 | 197 | |

(Note) Rated ripple current : 125°C , 100kHz
 ESR : 100kHz

Chip Type, 125°C Use, Low ESR, Long Life Capacitors

GREEN CAP SMD Low ESR 125°C 2000hours Anti-cleaning solvent

- Compatible with surface mounting.
- Supplied with carrier taping.
- Guarantees 2000 hours at 125°C.
($\phi 4$ to $\phi 8 \times 6.5L$: 1000 hours)
($\phi 12.5 \times 13.5L$: 5000 hours)

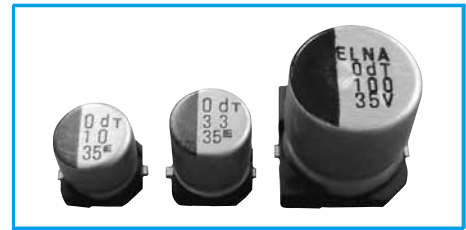
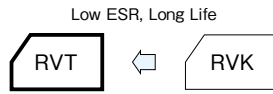

Marking color : Black print

Specifications

| Item | Performance | | | | | | | | | | |
|---|--|--|------|------|------|------|------|------|------|---------------|---------|
| Category temperature range (°C) | -40 to +125 | | | | | | | | | | |
| Tolerance at rated capacitance (%) | ±20 (20°C, 120Hz) | | | | | | | | | | |
| Leakage current (µA) | Less than 0.01CV or 3 whichever is larger (after 2 minutes) C : Rated capacitance (µF) ; V : Rated voltage (V) (20°C) | | | | | | | | | | |
| Tangent of loss angle | Rated voltage (V) | 10 | 16 | 25 | 35 | 50 | 63 | 80 | 100 | | |
| | Tangent of loss angle | 0.24 | 0.20 | 0.16 | 0.14 | 0.14 | 0.12 | 0.12 | 0.10 | (20°C, 120Hz) | |
| Characteristics at high and low temperature | Impedance Ratio (max.) | Rated voltage (V) | 10 | 16 | 25 | 35 | 50 | 63 | 80 | 100 | |
| | | Z-25°C/Z+20°C | 3 | 2 | 2 | 2 | 2 | 2 | 2 | 2 | 2 |
| | | Z-40°C/Z+20°C | 4 | 3 | 3 | 3 | 3 | 3 | 3 | 3 | (120Hz) |
| Endurance (125°C) | Test time | 2000 hours ($\phi 4$ to $\phi 8 \times 6.5L$: 1000 hours, $\phi 12.5 \times 13.5L$: 5000 hours) | | | | | | | | | |
| | Leakage current | The initial specified value or less | | | | | | | | | |
| | Capacitance change | Within ±30% of initial value | | | | | | | | | |
| | Tangent of loss angle | 300% or less of the initial specified value | | | | | | | | | |
| Shelf life (125°C) | Test time : 1000 hours ; other items are the same as those for the endurance. Voltage application treatment : According to JIS C5101-1 | | | | | | | | | | |
| Applicable standards | JIS C5101-1 1998, -18 1999 (IEC 60384-1 1992, -18 1993) | | | | | | | | | | |

Outline Drawing

Unit : mm

() : Reference size

| ϕD | L | A | B | C | M | W | P | Casing symbol |
|----------|----------|------|------|-----|---------|------------|-----|---------------|
| 4 | 5.8±0.3 | 4.3 | 4.3 | 2.0 | 0.4±0.2 | 0.5 to 0.8 | 1.0 | D61 |
| 5 | 5.8±0.3 | 5.3 | 5.3 | 2.3 | 0.4±0.2 | 0.5 to 0.8 | 1.5 | E61 |
| 6.3 | 5.8±0.3 | 6.6 | 6.6 | 2.7 | 0.4±0.2 | 0.5 to 0.8 | 2.0 | F61 |
| 6.3 | 7.7±0.3 | 6.6 | 6.6 | 2.7 | 0.4±0.2 | 0.5 to 0.8 | 2.0 | F80 |
| 8 | 6.5±0.3 | 8.4 | 8.4 | 3.4 | 0.4±0.2 | 0.5 to 0.8 | 2.3 | G68 |
| 8 | 10±0.5 | 8.4 | 8.4 | 3.0 | 0.4±0.2 | 0.7 to 1.1 | 3.1 | G10 |
| 8 | 10.5±0.5 | 8.4 | 8.4 | 3.0 | 0.4±0.2 | 0.7 to 1.1 | 3.1 | GA5 |
| 10 | 10±0.5 | 10.4 | 10.4 | 3.3 | 0.4±0.2 | 0.7 to 1.1 | 4.7 | H10 |
| 10 | 10.5±0.5 | 10.4 | 10.4 | 3.3 | 0.4±0.2 | 0.7 to 1.1 | 4.7 | HA5 |
| 12.5 | 13.5±0.5 | 13.0 | 13.0 | 4.9 | 0.7±0.3 | 1.0 to 1.4 | 4.6 | IE |

- Soldering conditions are described on page 13.
- Land pattern size are described on page 11.
- The taping specifications are described on page 14.

Coefficient of Frequency for Rated Ripple Current

| Frequency (Hz) | 120 | 1k | 10k | 100k |
|------------------|------|------|------|------|
| Rated voltage(V) | | | | |
| 10 to 100 | 0.77 | 0.88 | 0.96 | 1.00 |

Part numbering system

$\phi 10 \times 10.5L$ or less (16V100µF)

| | | | | | | | |
|-------------|----------------------|--------------------------|------------------------------|------------------------------|---------------|---------------|--|
| RVT | 35 | V | 221 | M | H10 | U | |
| Series code | Rated voltage symbol | Rated capacitance symbol | Capacitance tolerance symbol | Capacitance tolerance symbol | Casing symbol | Taping symbol | |

In the case of "for High Temperature Reflow" type, a series name is "RZC".

$\phi 12.5 \times 13.5$ (35V330µF)

| | | | | | | | |
|-------------|----------------------|--------------------------|------------------------------|------------------------------|---------------|---------------|----|
| RVT | 35 | V | 331 | M | IE | T | R5 |
| Series code | Rated voltage symbol | Rated capacitance symbol | Capacitance tolerance symbol | Capacitance tolerance symbol | Casing symbol | Taping symbol | |

Standard Ratings

| Rated voltage(V) Rated capacitance(μF) | Item | 10 | | | | 16 | | | | 25 | | | |
|---|-----------|-------------------|-------------|-------|---------------------------------|-------------------|-------------|-------|---------------------------------|-------------------|-------------|-------|---------------------------------|
| | | Case φD×L (mm) | ESR(Ω max.) | | Rated ripple current (mArms) | Case φD×L (mm) | ESR(Ω max.) | | Rated ripple current (mArms) | Case φD×L (mm) | ESR(Ω max.) | | Rated ripple current (mArms) |
| | | | 20°C | -40°C | | | 20°C | -40°C | | | 20°C | -40°C | |
| 10 | — | — | — | — | 4×5.8 | 3.0 | 45 | 50 | 5×5.8 | 1.5 | 23 | 81 | |
| 22 | 4×5.8 | 3.0 | 45 | 50 | 5×5.8 | 1.5 | 23 | 81 | 6.3×5.8 | 1.0 | 15 | 114 | |
| 33 | 5×5.8 | 1.5 | 23 | 81 | 6.3×5.8 | 1.0 | 15 | 114 | 6.3×5.8 | 1.0 | 15 | 114 | |
| 47 | — | — | — | — | 6.3×5.8 | 1.0 | 15 | 114 | 6.3×7.7 | 0.60 | 9.0 | 165 | |
| | — | — | — | — | | | | | 8×6.5 | 0.60 | 9.0 | 180 | |
| 100 | — | — | — | — | — | — | — | — | 6.3×7.7 | 0.60 | 9.0 | 165 | |
| | — | — | — | — | | | | | 8×6.5 | 0.60 | 9.0 | 180 | |
| | — | — | — | — | | | | | 8×10 | 0.20 | 2.0 | 340 | |
| 220 | 6.3×7.7 | 0.60 | 9.0 | 165 | 8×10 | 0.20 | 2.0 | 340 | 8×10 | 0.20 | 2.0 | 340 | |
| | 8×6.5 | 0.60 | 9.0 | 180 | 10×10 | 0.15 | 1.5 | 500 | 10×10 | 0.15 | 1.5 | 500 | |
| 330 | 8×10 | 0.20 | 2.0 | 340 | 10×10 | 0.15 | 1.5 | 500 | 10×10 | 0.15 | 1.5 | 500 | |
| | 10×10 | 0.15 | 1.5 | 500 | | | | | 12.5×13.5 | 0.086 | 1.29 | 750 | |
| 470 | 10×10 | 0.15 | 1.5 | 500 | 12.5×13.5 | 0.086 | 1.29 | 750 | 12.5×13.5 | 0.086 | 1.29 | 750 | |
| 680 | 12.5×13.5 | 0.086 | 1.29 | 750 | 12.5×13.5 | 0.086 | 1.29 | 750 | — | — | — | — | |
| 1000 | 12.5×13.5 | 0.086 | 1.29 | 750 | — | — | — | — | — | — | — | — | |

| Rated voltage(V) Rated capacitance(μF) | Item | 35 | | | | 50 | | | | 63 | | | |
|---|-----------|-------------------|-------------|-------|---------------------------------|-------------------|-------------|-------|---------------------------------|-------------------|-------------|-------|---------------------------------|
| | | Case φD×L (mm) | ESR(Ω max.) | | Rated ripple current (mArms) | Case φD×L (mm) | ESR(Ω max.) | | Rated ripple current (mArms) | Case φD×L (mm) | ESR(Ω max.) | | Rated ripple current (mArms) |
| | | | 20°C | -40°C | | | 20°C | -40°C | | | 20°C | -40°C | |
| 4.7 | 4×5.8 | 3.0 | 45 | 50 | — | — | — | — | — | — | — | — | |
| 10 | 5×5.8 | 1.5 | 23 | 81 | 6.3×5.8 | 3.2 | 48 | 58 | 6.3×7.7 | 1.8 | 36 | 95 | |
| | 6.3×5.8 | 1.0 | 15 | 114 | | | | | | | | | |
| 22 | 6.3×5.8 | 1.0 | 15 | 114 | 6.3×7.7 | 1.2 | 18 | 95 | 8×10 | 0.70 | 14 | 140 | |
| 33 | 6.3×7.7 | 0.60 | 9.0 | 165 | 6.3×7.7 | 1.2 | 18 | 95 | 8×10 | 0.70 | 14 | 140 | |
| | 8×6.5 | 0.60 | 9.0 | 180 | 8×10 | 0.50 | 7.5 | 180 | 10×10 | 0.50 | 10 | 200 | |
| 47 | 6.3×7.7 | 0.60 | 9.0 | 165 | 8×10 | 0.50 | 7.5 | 180 | 8×10 | 0.70 | 14 | 140 | |
| | 8×6.5 | 0.60 | 9.0 | 180 | | | | | | | | | |
| | 8×10 | 0.20 | 2.0 | 340 | | | | | | | | | |
| 100 | 8×10 | 0.20 | 2.0 | 340 | 10×10 | 0.30 | 4.5 | 280 | 12.5×13.5 | 0.25 | 3.75 | 400 | |
| | 10×10 | 0.15 | 1.5 | 500 | 12.5×13.5 | 0.18 | 2.7 | 550 | | | | | |
| 220 | 10×10 | 0.15 | 1.5 | 500 | 12.5×13.5 | 0.18 | 2.7 | 550 | — | — | — | — | |
| 330 | 12.5×13.5 | 0.086 | 1.29 | 750 | — | — | — | — | — | — | — | — | |

| Rated voltage(V) Rated capacitance(μF) | Item | 80 | | | | 100 | | | |
|---|-------|-------------------|-------------|-------|---------------------------------|-------------------|-------------|-------|---------------------------------|
| | | Case φD×L (mm) | ESR(Ω max.) | | Rated ripple current (mArms) | Case φD×L (mm) | ESR(Ω max.) | | Rated ripple current (mArms) |
| | | | 20°C | -40°C | | | 20°C | -40°C | |
| 10 | 8×10 | 0.75 | 15 | 110 | 8×10 | 0.75 | 15 | 110 | |
| 22 | 8×10 | 0.75 | 15 | 110 | 8×10 | 0.75 | 15 | 110 | |
| | 10×10 | 0.55 | 11 | 150 | 10×10 | 0.55 | 11 | 150 | |
| 33 | 8×10 | 0.75 | 15 | 110 | 10×10 | 0.55 | 11 | 150 | |
| | 10×10 | 0.55 | 11 | 150 | | | | | |
| 47 | — | — | — | — | 12.5×13.5 | 0.32 | 4.8 | 300 | |

(Note) Rated ripple current : 125°C, 100kHz
ESR : 100kHz

Chip Type 125°C Capacitors

GREEN CAP SMD 125°C 1250hours 105°C 5000hours Anti-cleaning solvent

- Compatible with surface mounting.
- Supplied with carrier taping.
- Guarantees 1250 hours at 125°C.
($\phi 8$: 1000 hours)
($\phi 12.5$: 5000 hours)
- Guarantees 5000 hours at 105°C.
($\phi 8$: 4000 hours)



High temperature

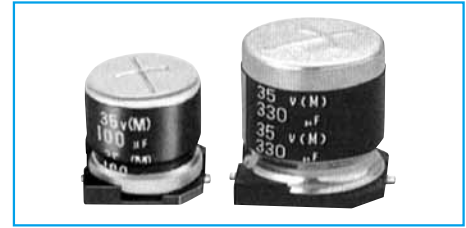

Marking color : Gold print on a brown sleeve ($\phi 8$, $\phi 10$)
White print on a brown sleeve ($\phi 12.5$)

Specifications

| Item | Performance | | | | | | | | |
|---|--|--|------|---------------|------|-------------------------------------|------|--|--|
| Category temperature range (°C) | -40 to +125 | | | | | | | | |
| Tolerance at rated capacitance (%) | ± 20 (20°C, 120Hz) | | | | | | | | |
| Leakage current (μA) | Less than 0.02CV or 3 whichever is larger (after 2 minutes) C : Rated capacitance (μF) ; V : Rated voltage (V) (20°C) | | | | | | | | |
| Tangent of loss angle (tan δ) | Rated voltage (V) | 10 | 16 | 25 | 35 | 50 | 63 | | |
| | tan δ (max.) | 0.28 | 0.26 | 0.24 | 0.20 | 0.19 | 0.18 | | |
| Characteristics at high and low temperature | Impedance ratio (max.) | Z-25°C/Z+20°C | | Z-40°C/Z+20°C | | | | | |
| | | 10 | 16 | 25 | 35 | 50 | 63 | | |
| | | 3 | 3 | 3 | 3 | 3 | 3 | | |
| Endurance (Applied ripple current) | Test temp. | 125°C | | | | 105°C | | | |
| | Test time | $\phi 8$: 1000h, $\phi 10$: 1250h, $\phi 12.5$: 5000h | | | | $\phi 8$: 4000h, $\phi 10$: 5000h | | | |
| | Leakage current | The initial specified value or less | | | | | | | |
| | Percentage of capacitance change | Within $\pm 30\%$ of initial value | | | | | | | |
| | Tangent of the loss angle | 300% or less of the initial specified value | | | | | | | |
| Shelf life | Test temp. | 125°C | | | | 105°C | | | |
| | Test time | 500 h | | | | 1000h | | | |
| | Leakage current | The initial specified value or less | | | | | | | |
| | Percentage of capacitance change | Within $\pm 20\%$ of initial value | | | | | | | |
| | Tangent of the loss angle | 200% or less of the initial specified value | | | | | | | |
| Applicable standards | JIS C5101-1 1998, -18 1999 (IEC 60384-1 1992, -18 1993) | | | | | | | | |

Outline Drawing

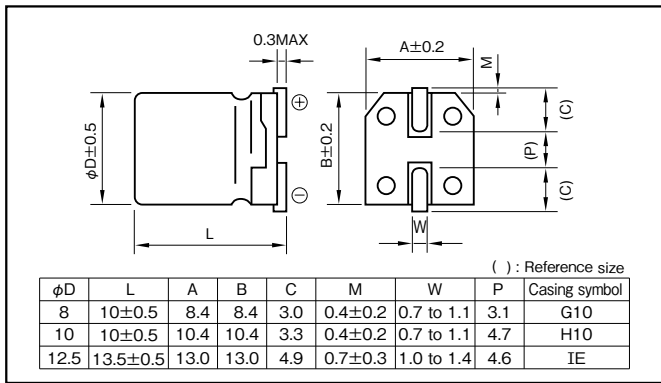

- Soldering conditions are described on page 13.
- Land pattern size are described on page 11.
- The taping specifications are described on page 14.

Standard Ratings

| Rated capacitance (μF) | 10 | | | | 16 | | | | 25 | | | | 35 | | | | 50 | | | | 63 | | | | | | | |
|-------------------------------|--------------------|---------------|----------------------------|-------------------------------|--------------------|---------------|----------------------------|-------------------------------|--------------------|---------------|----------------------------|-------------------------------|--------------------|---------------|----------------------------|-------------------------------|--------------------|---------------|----------------------------|-------------------------------|--------------------|---------------|----------------------------|-------------------------------|--------------------|-----|-------|-----|
| | Case | Casing symbol | Impedance (Ω max.) | Rated ripple current (mA rms) | Case | Casing symbol | Impedance (Ω max.) | Rated ripple current (mA rms) | Case | Casing symbol | Impedance (Ω max.) | Rated ripple current (mA rms) | Case | Casing symbol | Impedance (Ω max.) | Rated ripple current (mA rms) | Case | Casing symbol | Impedance (Ω max.) | Rated ripple current (mA rms) | Case | Casing symbol | Impedance (Ω max.) | Rated ripple current (mA rms) | | | | |
| 10 | — | — | — | — | — | — | — | — | — | — | — | — | — | — | — | — | 8 \times 10 | G10 | 0.800 | 38 | — | — | — | — | | | | |
| 22 | — | — | — | — | — | — | — | — | — | — | — | — | — | — | — | — | 8 \times 10 | G10 | 0.800 | 38 | 8 \times 10 | G10 | 1.00 | 33 | | | | |
| 33 | — | — | — | — | — | — | — | — | — | — | — | — | — | — | — | — | 8 \times 10 | G10 | 0.800 | 40 | 10 \times 10 | H10 | 0.600 | 58 | | | | |
| 47 | — | — | — | — | — | — | — | — | — | — | — | — | — | — | — | — | 8 \times 10 | G10 | 0.680 | 55 | 8 \times 10 | G10 | 0.800 | 40 | 10 \times 10 | H10 | 0.600 | 58 |
| 100 | — | — | — | — | 8 \times 10 | G10 | 0.680 | 60 | 8 \times 10 | G10 | 0.680 | 60 | 10 \times 10 | H10 | 0.550 | 102 | 10 \times 10 | H10 | 0.550 | 102 | 12.5 \times 13.5 | IE | 0.136 | 509 | 12.5 \times 13.5 | IE | 0.176 | 447 |
| 220 | 8 \times 10 | G10 | 0.680 | 60 | 10 \times 10 | H10 | 0.550 | 107 | 10 \times 10 | H10 | 0.550 | 107 | 10 \times 10 | H10 | 0.550 | 102 | 12.5 \times 13.5 | IE | 0.105 | 579 | 12.5 \times 13.5 | IE | 0.136 | 509 | — | — | — | — |
| 330 | 10 \times 10 | H10 | 0.550 | 111 | 10 \times 10 | H10 | 0.550 | 111 | 12.5 \times 13.5 | IE | 0.105 | 579 | 12.5 \times 13.5 | IE | 0.105 | 579 | — | — | — | — | — | — | — | — | — | — | — | — |
| 470 | 12.5 \times 13.5 | IE | 0.105 | 579 | 12.5 \times 13.5 | IE | 0.105 | 579 | 12.5 \times 13.5 | IE | 0.105 | 579 | 12.5 \times 13.5 | IE | 0.105 | 579 | — | — | — | — | — | — | — | — | — | — | — | — |
| 680 | 12.5 \times 13.5 | IE | 0.105 | 579 | 12.5 \times 13.5 | IE | 0.105 | 579 | — | — | — | — | — | — | — | — | — | — | — | — | — | — | — | — | — | — | — | — |
| 1000 | 12.5 \times 13.5 | IE | 0.105 | 579 | — | — | — | — | — | — | — | — | — | — | — | — | — | — | — | — | — | — | — | — | — | — | — | — |

(Note) Rated ripple current : 125°C, 100kHz ; Impedance : 20°C, 100kHz

Coefficient of Frequency for Rated Ripple Current

| Rated voltage (V) | Frequency (Hz) | | | |
|-------------------|----------------|------|------|------|
| | 120 | 1k | 10k | 100k |
| 10 to 63 | 0.77 | 0.88 | 0.96 | 1 |

| Rated capacitance (μF) | Frequency (Hz) | | | |
|-------------------------------|----------------|------|------|------|
| | 120 | 1k | 10k | 100k |
| 100 | 0.40 | 0.75 | 0.90 | 1 |
| 220 to 330 | 0.50 | 0.85 | 0.95 | 1 |
| 470 to 1000 | 0.60 | 0.88 | 0.96 | 1 |

Part numbering system

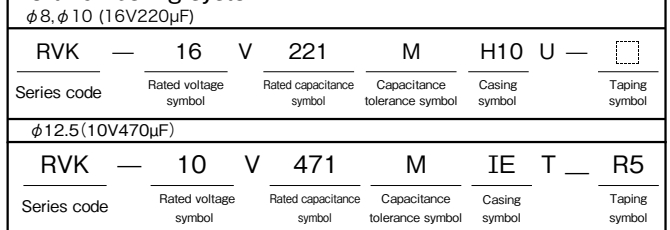

Chip Type, 135°C Capacitors

GREEN CAP SMD 135°C 1000hours Anti-cleaning solvent

- Compatible with surface mounting.
- Supplied with carrier taping.
- Guarantees 1000 hours 135°C.

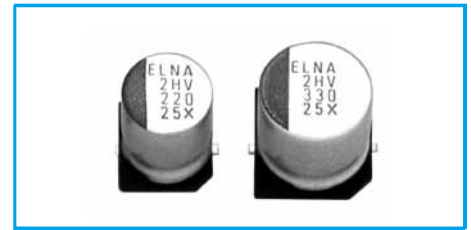
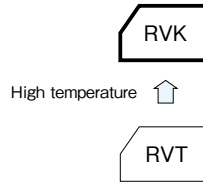

Marking color : Black print

Specifications

| Item | Performance | | | |
|---|---|---|------|---|
| Category temperature range (°C) | -40 to +135 | | | |
| Tolerance at rated capacitance (%) | ±20 (20°C, 120Hz) | | | |
| Leakage current (µA) | Less than 0.01CV or 3 whichever is larger (after 2 minutes) C : Rated capacitance (µF) ; V : Rated voltage (V) (20°C) | | | |
| Tangent of loss angle (tanδ) | Rated voltage (V) | 25 | 35 | |
| | tanδ (max.) | 0.24 | 0.20 | |
| Characteristics at high and low temperature | Rated voltage (V) | 25 | 35 | |
| | Impedance Ratio (max.) | Z-25°C/Z+20°C | 2 | 2 |
| | | Z-40°C/Z+20°C | 3 | 3 |
| Endurance (135°C) | Test time | 1000 hours | | |
| | Leakage current | The initial specified value or less | | |
| | Percentage of Capacitance change | Within ±20% of initial value | | |
| | Tangent of loss angle | 300% or less of the initial specified value | | |
| Shelf life (135°C) | Test time : 500 hours ; other items are the same as those for the endurance. Voltage application treatment | | | |
| Applicable standards | JIS C5101-1 1998, -18 1999 (IEC 60384-1 1992, -18 1993) | | | |

Outline Drawing

Unit : mm

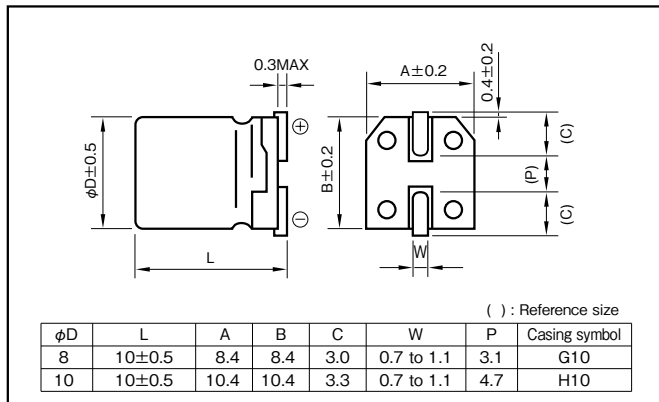

Coefficient of Frequency for Rated Ripple Current

| Frequency (Hz) | 120 | 1k | 10k | 100k |
|------------------|------|------|------|------|
| Rated voltage(V) | | | | |
| 25 to 35 | 0.77 | 0.88 | 0.96 | 1 |

Part numbering system (example : 25V331 M H10 U)

| | | | | | | | | |
|-------------|---|----------------------|---|--------------------------|------------------------------|---------------|---|---------------|
| RVX | — | 25 | V | 331 | M | H10 | U | □ |
| Series code | | Rated voltage symbol | | Rated capacitance symbol | Capacitance tolerance symbol | Casing symbol | | Taping symbol |

- Soldering conditions are described on page 13.
- Land pattern size are described on page 11.
- The taping specifications are described on page 14.

Standard Ratings

| Rated voltage (V) | Item | 25 | | | | 35 | | | |
|-------------------|------|-------|---------------|--------------|-------------------------------|-------|---------------|--------------|-------------------------------|
| | | Case | Casing symbol | ESR (Ω max.) | Rated ripple current (mA rms) | Case | Casing symbol | ESR (Ω max.) | Rated ripple current (mA rms) |
| 22 | 33 | 8×10 | G10 | 0.70 | 115 | 8×10 | G10 | 0.70 | 115 |
| | | 10×10 | H10 | 0.50 | 155 | 10×10 | H10 | 0.50 | 155 |
| 47 | 100 | 8×10 | G10 | 0.70 | 115 | 8×10 | G10 | 0.70 | 115 |
| | | 10×10 | H10 | 0.50 | 155 | 10×10 | H10 | 0.50 | 155 |
| 220 | 330 | 8×10 | G10 | 0.70 | 115 | 10×10 | H10 | 0.50 | 155 |
| | | 10×10 | H10 | 0.50 | 155 | | | | |

(Note) Rated ripple current : 135°C, 100kHz
ESR : 20°C, 100kHz

Chip type 105°C Capacitors(height:4.5mm)

GREEN CAP

SMD

105°C
1000hours

Anti-cleaning solvent

- Compatible with surface mounting for 4.5mm height capacitors.
- Supplied with carrier taping.
- Guarantees 1000 hours 105°C.

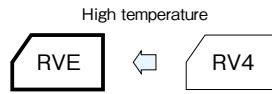

Marking color : Black print

Specifications

| Item | Performance | | | | | | |
|---|--|--|------|------|------|------|------|
| Category temperature range (°C) | -40 to +105 | | | | | | |
| Tolerance at rated capacitance (%) | ±20 (20°C,120Hz) | | | | | | |
| Leakage current (µA) | Less than 0.01CV or 3 whichever is larger (after 2 minutes) C : Rated capacitance (µF), V : Rated voltage (V) (20°C) | | | | | | |
| Tangent of loss angle (tanδ) | Rated voltage (V) | 6.3 | 10 | 16 | 25 | 35 | 50 |
| | tanδ (max.) | 0.38 | 0.32 | 0.20 | 0.16 | 0.14 | 0.14 |
| Characteristics at high and low temperature | Rated voltage (V) | Z-25°C/Z+20°C | 4 | 3 | 2 | 2 | 2 |
| | | Z-40°C/Z+20°C | 10 | 8 | 6 | 4 | 3 |
| | Impedance ratio (max.) | (120Hz) | | | | | |
| Endurance (105°C) | Test time | 1000 hours | | | | | |
| | Leakage current | The initial specified value or less | | | | | |
| | Percentage of capacitance change | Within ±20% of initial value (16VV or less:±25%) | | | | | |
| | Tangent of loss angle | 300% or less of the initial specified value | | | | | |
| Shelf life (105°C) | Test time : 500 hours ; other items are the same as those for the endurance. Voltage application treatment | | | | | | |
| Applicable standards | JIS C5101-1 1998, -18 1999 (IEC 60384-1 1992, -18 1993) | | | | | | |

Outline Drawing

Unit : mm

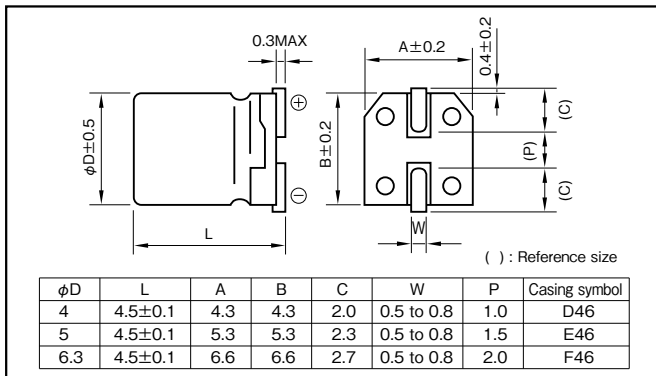

Coefficient of Frequency for Rated Ripple Current

| Rated voltage (V) | Frequency (Hz) | | | |
|-------------------|----------------|------|------|------------|
| | 50 · 60 | 120 | 1k | 10k · 100k |
| 6.3 to 16 | 0.80 | 1.00 | 1.15 | 1.25 |
| 25 to 35 | 0.80 | 1.00 | 1.25 | 1.40 |
| 50 | 0.1 to 3.3µF | 0.50 | 1.00 | 1.35 |
| | 4.7µF to 10µF | 0.70 | 1.00 | 1.35 |

Part numbering system (example : 16V10µF)

| | | | | | | | | |
|-------------|---|----------------------|---|--------------------------|------------------------------|---------------|---|---------------|
| RVE | — | 16 | V | 100 | M | D46 | U | □ |
| Series code | | Rated voltage symbol | | Rated capacitance symbol | Capacitance tolerance symbol | Casing symbol | | Taping symbol |

- Soldering conditions are described on page 13.
- Land pattern size are described on page 11.
- The taping specifications are described on page 14.

Standard Ratings

| Rated voltage (V) | 6.3 | | | 10 | | | 16 | | | 25 | | | 35 | | | 50 | | |
|-------------------|-------------|---------------|---|-------------|---------------|---|-------------|---------------|---|-------------|---------------|---|-------------|---------------|---|-------------|---------------|---|
| | Case φD(mm) | Casing symbol | Rated ripple current (mA _{rms}) | Case φD(mm) | Casing symbol | Rated ripple current (mA _{rms}) | Case φD(mm) | Casing symbol | Rated ripple current (mA _{rms}) | Case φD(mm) | Casing symbol | Rated ripple current (mA _{rms}) | Case φD(mm) | Casing symbol | Rated ripple current (mA _{rms}) | Case φD(mm) | Casing symbol | Rated ripple current (mA _{rms}) |
| 0.22 | — | — | — | — | — | — | — | — | — | — | — | — | — | — | — | 4 | D46 | 2.2 |
| 0.33 | — | — | — | — | — | — | — | — | — | — | — | — | — | — | — | 4 | D46 | 2.8 |
| 0.47 | — | — | — | — | — | — | — | — | — | — | — | — | — | — | — | 4 | D46 | 3.3 |
| 1 | — | — | — | — | — | — | — | — | — | — | — | — | — | — | — | 4 | D46 | 5.4 |
| 2.2 | — | — | — | — | — | — | — | — | — | — | — | — | — | — | — | 4 | D46 | 9.6 |
| 3.3 | — | — | — | — | — | — | — | — | — | — | — | — | — | — | — | 4 | D46 | 12 |
| 4.7 | — | — | — | — | — | — | — | — | — | 4 | D46 | 11 | 4 | D46 | 13 | 5 | E46 | 16 |
| 10 | — | — | — | — | — | — | 4 | D46 | 16 | 5 | E46 | 20 | 5 | E46 | 22 | 6.3 | F46 | 26 |
| 22 | 4 | D46 | 19 | 5 | E46 | 24 | 5 | E46 | 26 | 6.3 | F46 | 33 | 6.3 | F46 | 36 | — | — | — |
| 33 | 5 | E46 | 26 | 5 | E46 | 30 | 6.3 | F46 | 35 | 6.3 | F46 | 42 | — | — | — | — | — | — |
| 47 | 5 | E46 | 32 | 6.3 | F46 | 40 | 6.3 | F46 | 44 | — | — | — | — | — | — | — | — | — |
| 100 | 6.3 | F46 | 52 | — | — | — | — | — | — | — | — | — | — | — | — | — | — | — |

(Note) Rated ripple current : 105°C, 120Hz

Chip Type 105°C Use, Long Life Bipolar Capacitors

GREEN CAP SMD 105°C 2000hours Anti-cleaning solvent

- Compatible with surface mounting.
- Supplied with carrier taping.
- Guarantees 2000 hours 105°C.

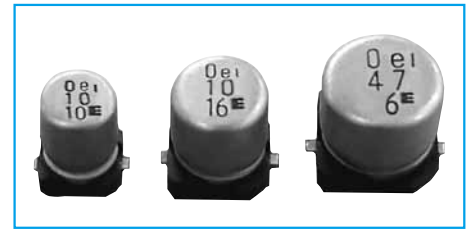
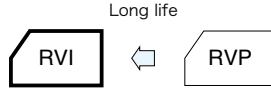

Marking color : Black print

Specifications

| Item | Performance | | | | | | | |
|---|---|---|------|------|------|------|------|---|
| Category temperature range (°C) | -40 to +105 | | | | | | | |
| Tolerance at rated capacitance (%) | ±20 (20°C,120Hz) | | | | | | | |
| Leakage current (μA) | Less than 0.01CV or 3 whichever is larger (after 2 minutes) C : Rated capacitance (μF) , V : Rated voltage (V) (20°C) | | | | | | | |
| Tangent of loss angle (tanδ) | Rated voltage (V) | 6.3 | 10 | 16 | 25 | 35 | 50 | |
| | tanδ (max.) | 0.30 | 0.22 | 0.16 | 0.14 | 0.12 | 0.12 | |
| Characteristics at high and low temperature | Rated voltage (V) | 6.3 | 10 | 16 | 25 | 35 | 50 | |
| | Impedance ratio (max.) | Z-25°C/Z+20°C | 4 | 3 | 2 | 2 | 2 | 2 |
| | | Z-40°C/Z+20°C | 8 | 6 | 4 | 4 | 3 | 3 |
| Endurance (105°C) | Test time | 2000 hours (with the polarity inverted every 250 hours) | | | | | | |
| | Leakage current | The initial specified value or less | | | | | | |
| | Percentage of capacitance change | Within ±20% of initial value | | | | | | |
| | Tangent of loss angle | 200% or less of the initial specified value | | | | | | |
| Shelf life (105°C) | Test time : 1000 hours ; other items are the same as those for the endurance. Voltage application treatment | | | | | | | |
| Applicable standards | JIS C5101-1 1998, -18 1999 (IEC 60384-1 1992, -18 1993) | | | | | | | |

CHIP ALUMINUM

Outline Drawing

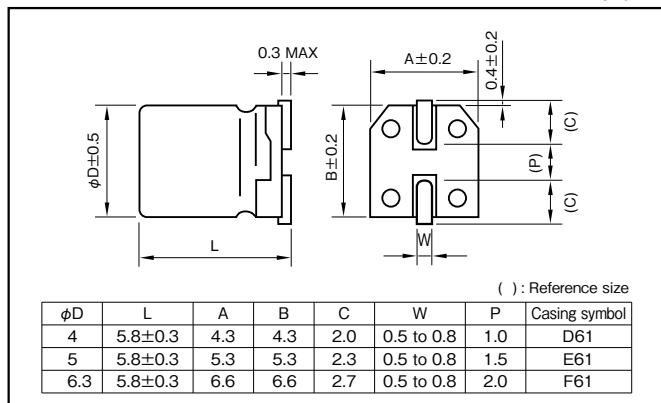

Coefficient of Frequency for Rated Ripple Current

| Rated voltage (V) | Frequency (Hz) | | | |
|-------------------|----------------|------|------|------------|
| | 50 - 60 | 120 | 1k | 10k · 100k |
| 6.3 to 16 | 0.80 | 1 | 1.15 | 1.25 |
| 25 to 35 | 0.80 | 1 | 1.25 | 1.40 |
| 50 | 0.1 to 3.3μF | 0.50 | 1 | 1.35 |
| | 4.7μF | 0.70 | 1 | 1.35 |

Part numbering system (example : 6.3V47μF)

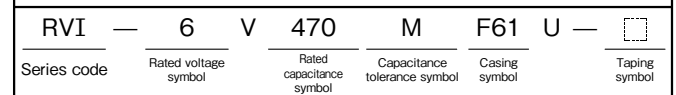

- Soldering conditions are described on page 13.
- Land pattern size are described on page 11.
- The taping specifications are described on page 14.

Standard Ratings

| Rated capacitance (μF) | 6.3 | | 10 | | 16 | | 25 | | 35 | | 50 | |
|------------------------|--------------|------------------------------|--------------|------------------------------|--------------|------------------------------|--------------|------------------------------|--------------|------------------------------|--------------|------------------------------|
| | Case φD (mm) | Rated ripple current (mArms) | Case φD (mm) | Rated ripple current (mArms) | Case φD (mm) | Rated ripple current (mArms) | Case φD (mm) | Rated ripple current (mArms) | Case φD (mm) | Rated ripple current (mArms) | Case φD (mm) | Rated ripple current (mArms) |
| 0.33 | - | - | - | - | - | - | - | - | - | - | 4 | 3 |
| 0.47 | - | - | - | - | - | - | - | - | - | - | 4 | 5 |
| 1 | - | - | - | - | - | - | - | - | - | - | 4 | 10 |
| 2.2 | - | - | - | - | - | - | - | - | 4 | 10 | - | - |
| 3.3 | - | - | - | - | - | - | 4 | 12 | - | - | 5 | 17 |
| 4.7 | - | - | - | - | - | - | 4 | 12 | - | - | 6.3 | 20 |
| | - | - | - | - | - | - | - | - | - | - | 6.3 | 23 |
| 10 | - | - | 4 | 20 | 5 | 25 | 6.3 | 28 | - | - | - | - |
| 22 | - | - | - | - | - | - | 6.3 | 55 | - | - | - | - |
| 33 | - | - | 6.3 | 41 | - | - | - | - | - | - | - | - |
| 47 | 6.3 | 45 | - | - | - | - | - | - | - | - | - | - |

(Note) Rated ripple current : 105°C, 120Hz

Chip Type 125°C Capacitors

- SMD
- Vibration Resistance
- 125°C 1250hours
- 105°C 5000hours
- Anti-cleaning solvent

- Compatible with surface mounting.
- For Vibration resistance.
- Supplied with carrier taping.
- Guarantees 1250 hours at 125°C. (φ8 : 1000 hours)
- Guarantees 5000 hours at 105°C. (φ8 : 4000 hours)



↑ Vibration resistance



Marking color : Gold print on a brown sleeve

Specifications

| Item | Performance | | | | | | | | |
|---|---|---|------|------|------|-------------------------|------|--------------|---------|
| Category temperature range (°C) | -40 to +125 | | | | | | | | |
| Tolerance at rated capacitance (%) | ±20 (20°C,120Hz) | | | | | | | | |
| Leakage current (μA) | Less than 0.02CV or 3 whichever is larger (after 2 minutes) C : Rated capacitance (μF) ; V : Rated voltage (V) (20°C) | | | | | | | | |
| Tangent of loss angle (tanδ) | Rated voltage (V) | 10 | 16 | 25 | 35 | 50 | 63 | | |
| | tanδ (max.) | 0.28 | 0.26 | 0.24 | 0.20 | 0.19 | 0.18 | (20°C,120Hz) | |
| Characteristics at high and low temperature | Rated voltage (V) | 10 | 16 | 25 | 35 | 50 | 63 | | |
| | Impedance ratio (max.) | Z-25°C/Z+20°C | 3 | 3 | 3 | 3 | 3 | 3 | (120Hz) |
| | | Z-40°C/Z+20°C | 5 | 5 | 5 | 5 | 5 | 5 | |
| Endurance (Applied ripple current) | Test temp. | 125°C | | | | 105°C | | | |
| | Test time | φ8 : 1000h, φ10 : 1250h | | | | φ8 : 4000h, φ10 : 5000h | | | |
| | Leakage current | The initial specified value or less | | | | | | | |
| | Percentage of capacitance change | Within ±30% of initial value | | | | | | | |
| | Tangent of the loss angle | 300% or less of the initial specified value | | | | | | | |
| Shelf life | Test temp. | 125°C | | | | 105°C | | | |
| | Test time | 500 h | | | | 1000h | | | |
| | Leakage current | The initial specified value or less | | | | | | | |
| | Percentage of capacitance change | Within ±20% of initial value | | | | | | | |
| | Tangent of the loss angle | 200% or less of the initial specified value | | | | | | | |
| Applicable standards | JIS C5101-1 1998, -18 1999 (IEC 60384-1 1992, -18 1993) | | | | | | | | |

Outline Drawing

Unit : mm

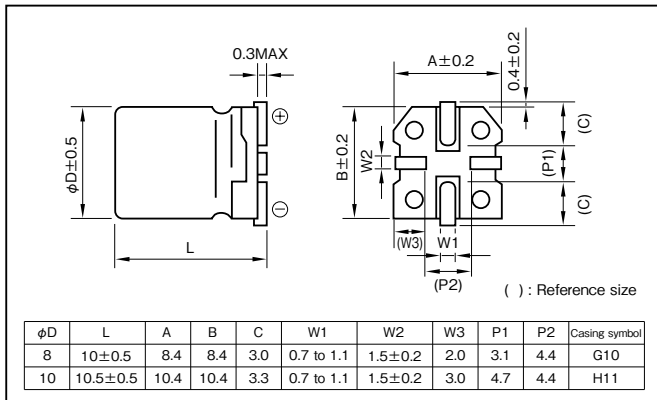

- Soldering conditions are described on page 13.
- Land pattern size are described on page 11.
- The taping specifications are described on page 14.

Coefficient of Frequency for Rated Ripple Current

| Frequency (Hz) | 120 | 1k | 10k | 100k |
|-------------------|------|------|------|------|
| Rated voltage (V) | | | | |
| 10 to 63 | 0.77 | 0.88 | 0.96 | 1 |

Part numbering system (example : 16V220μF)

| | | | | | | | | |
|-------------|---|----------------------|---|--------------------------|------------------------------|---------------|---|---------------|
| RTK | — | 16 | V | 221 | M | H11 | U | □ |
| Series code | | Rated voltage symbol | | Rated capacitance symbol | Capacitance tolerance symbol | Casing symbol | | Taping symbol |

Standard Ratings

| Rated voltage (V) | 10 | | | | 16 | | | | 25 | | | | 35 | | | | 50 | | | | 63 | | | |
|------------------------|-----------|-----|-----------|----------------------|-----------|-----|-----------|----------------------|-----------|-----|-----------|----------------------|-----------|-----|-----------|----------------------|-----------|-----|-----------|----------------------|-----------|-----|-----------|----------------------|
| | Case | ESR | Impedance | Rated ripple current | Case | ESR | Impedance | Rated ripple current | Case | ESR | Impedance | Rated ripple current | Case | ESR | Impedance | Rated ripple current | Case | ESR | Impedance | Rated ripple current | Case | ESR | Impedance | Rated ripple current |
| Rated capacitance (μF) | φD×L (mm) | (Ω) | (Ω max.) | (mA _{rms}) | φD×L (mm) | (Ω) | (Ω max.) | (mA _{rms}) | φD×L (mm) | (Ω) | (Ω max.) | (mA _{rms}) | φD×L (mm) | (Ω) | (Ω max.) | (mA _{rms}) | φD×L (mm) | (Ω) | (Ω max.) | (mA _{rms}) | φD×L (mm) | (Ω) | (Ω max.) | (mA _{rms}) |
| 10 | — | — | — | — | — | — | — | — | — | — | — | — | — | — | — | — | 8×10 | 32 | 0.80 | 38 | — | — | — | — |
| | | | | | | | | | | | | | | | | | 10×10.5 | 32 | 0.65 | 45 | — | — | — | — |
| 22 | — | — | — | — | — | — | — | — | — | — | — | — | — | — | — | — | 8×10 | 14 | 0.80 | 38 | 8×10 | 14 | 1.00 | 33 |
| | | | | | | | | | | | | | | | | | 10×10.5 | 14 | 0.65 | 48 | 10×10.5 | 14 | 0.67 | 48 |
| 33 | — | — | — | — | — | — | — | — | — | — | — | — | — | — | — | — | 8×10 | 10 | 0.80 | 40 | — | — | — | — |
| | | | | | | | | | | | | | | | | | 10×10.5 | 10 | 0.60 | 58 | — | — | — | — |
| 47 | — | — | — | — | — | — | — | — | — | — | — | — | — | — | — | — | 8×10 | 7.1 | 0.68 | 65 | 8×10 | 6.7 | 0.80 | 40 |
| | | | | | | | | | | | | | | | | | 10×10.5 | 7.1 | 0.58 | 70 | 10×10.5 | 6.7 | 0.60 | 58 |
| 100 | — | — | — | — | 8×10 | 4.3 | 0.68 | 60 | 8×10 | 4.0 | 0.68 | 60 | 10×10.5 | 3.3 | 0.55 | 102 | — | — | — | — | — | — | — | — |
| | | | | | | | | | | | | | | | | | 8×10 | 2.1 | 0.68 | 60 | — | — | — | — |
| 220 | — | — | — | — | 10×10.5 | 2.0 | 0.55 | 107 | 10×10.5 | 1.8 | 0.55 | 107 | — | — | — | — | 10×10.5 | 2.1 | 0.55 | 111 | — | — | — | — |
| | | | | | | | | | | | | | | | | | 10×10.5 | 1.4 | 0.55 | 111 | — | — | — | — |
| 330 | — | — | — | — | 10×10.5 | 1.3 | 0.55 | 111 | — | — | — | — | — | — | — | — | 10×10.5 | 1.3 | 0.55 | 111 | — | — | — | — |

(Note) Rated ripple current : 125°C, 100kHz ; Impedance : 20°C, 100kHz ; ESR : 20°C, 120Hz

Chip Type 105°C Use, Low Z, For Vibration Capacitors

GREEN CAP SMD Vibration Resistance Low Z 105°C 2000hours

- Compatible with surface mounting.
- For Vibration resistance. (30G guaranteed)
- Supplied with carrier taping.
- Guarantees 2000 hours at 105°C. (φ12.5 to φ18 : 5000hours)

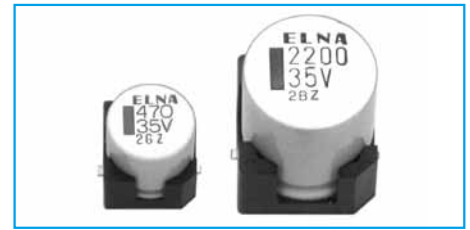
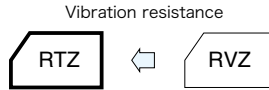

Marking color : Black print

Specifications

| Item | Performance | | | | | | |
|---|--|---|------|------|------|------|---|
| Category temperature range (°C) | -55 to +105 | | | | | | |
| Tolerance at rated capacitance (%) | ±20 (20°C,120Hz) | | | | | | |
| Leakage current (μA) | Less than 0.01CV or 3 whichever is larger (after 2 minutes) C : Rated capacitance (μF) , V : Rated voltage (V) (20°C) | | | | | | |
| Tangent of loss angle (tanδ) | Rated voltage (V) | 6.3 | 10 | 16 | 25 | 35 | |
| | tanδ (max.) | 0.28 | 0.24 | 0.20 | 0.16 | 0.14 | |
| 0.02 is added to every 1000μF increase over 1000μF (20°C,120Hz) | | | | | | | |
| Characteristics at high and low temperature | Rated voltage (V) | 6.3 | 10 | 16 | 25 | 35 | |
| | Impedance ratio (max.) | Z-25°C/Z+20°C | 4 | 3 | 2 | 2 | 2 |
| | | Z-55°C/Z+20°C | 8 | 5 | 4 | 3 | 3 |
| (120Hz) | | | | | | | |
| Endurance (105°C) (Applied ripple current) | Test time | 2000 hours (φ8, 10) 5000 hours (φ12.5 to 18) | | | | | |
| | Leakage current | The initial specified value or less | | | | | |
| | Percentage of capacitance change | Within ±25% of initial value | | | | | |
| | Tangent of loss angle | 200% or less of the initial specified value | | | | | |
| Shelf life (105°C) | Test time : 1000 hours ; other items are the same as those for the endurance. Voltage application treatment : According to JIS C5101-1 | | | | | | |
| Applicable standards | JIS C5101-1 1998, -18 1999 (IEC 60384-1 1992, -18 1993) | | | | | | |

Outline Drawing

Unit : mm

| φD | L | A | B | C | W | P | M | Casing symbol |
|------|----------|------|------|-----|------------|-----|---------|---------------|
| 8 | 10±0.5 | 8.4 | 8.4 | 3.0 | 0.7 to 1.1 | 3.1 | 0.4±0.2 | G10 |
| 8 | 10.5±0.5 | 8.4 | 8.4 | 3.0 | 0.7 to 1.1 | 3.1 | 0.4±0.2 | GA5 |
| 10 | 10±0.5 | 10.4 | 10.4 | 3.3 | 0.7 to 1.1 | 4.7 | 0.4±0.2 | H10 |
| 10 | 10.5±0.5 | 10.4 | 10.4 | 3.3 | 0.7 to 1.1 | 4.7 | 0.4±0.2 | HA5 |
| 12.5 | 13.5±0.5 | 13.0 | 13.0 | 4.9 | 1.0 to 1.4 | 4.6 | 0.7±0.3 | IE |
| 16 | 16.5±0.5 | 17.0 | 17.0 | 5.6 | 1.0 to 1.4 | 7.2 | 0.7±0.3 | JH |
| 16 | 21.5±0.5 | 17.0 | 17.0 | 5.6 | 1.0 to 1.4 | 7.2 | 0.7±0.3 | JM |
| 18 | 16.5±0.5 | 19.0 | 19.0 | 6.6 | 1.0 to 1.4 | 7.2 | 0.7±0.3 | KH |
| 18 | 21.5±0.5 | 19.0 | 19.0 | 6.6 | 1.0 to 1.4 | 7.2 | 0.7±0.3 | KM |

Coefficient of Frequency for Rated Ripple Current

| Frequency (Hz) | 120 | 1k | 10k | 100k |
|-------------------|------|------|------|------|
| Rated voltage (V) | | | | |
| 6.3 to 35 | 0.50 | 0.75 | 0.90 | 1 |

Part numbering system

φ8, φ10 (6.3V1500μF)

| | | | | | | | |
|-------------|----------------------|--------------------------|------------------------------|---------------|---------------|----|--|
| RTZ | 6 | V | 152 | M | HA5 | SU | |
| Series code | Rated voltage symbol | Rated capacitance symbol | Capacitance tolerance symbol | Casing symbol | Taping symbol | | |

φ12.5 or more (6.3V2200μF)

| | | | | | | | |
|-------------|----------------------|--------------------------|------------------------------|---------------|---------------|---|--|
| RTZ | 6 | V | 222 | M | IE | T | |
| Series code | Rated voltage symbol | Rated capacitance symbol | Capacitance tolerance symbol | Casing symbol | Taping symbol | | |

- Soldering conditions are described on page 13.
- Land pattern size are described on page 11.
- The taping specifications are described on page 14.

Standard Ratings

| Rated voltage (V) | Item | 6.3 | | | | 10 | | | | 16 | | | | 25 | | | | 35 | | | | | | | | | | | |
|-------------------|------|-----------|---------------|--------------------|-------------------------------|-----------|---------------|--------------------|-------------------------------|-----------|---------------|--------------------|-------------------------------|-----------|---------------|--------------------|-------------------------------|-----------|---------------|--------------------|-------------------------------|-----------|-----|-------|------|-----------|-----|-------|------|
| | | Case | Casing symbol | Impedance (Ω max.) | Rated ripple current (mA rms) | Case | Casing symbol | Impedance (Ω max.) | Rated ripple current (mA rms) | Case | Casing symbol | Impedance (Ω max.) | Rated ripple current (mA rms) | Case | Casing symbol | Impedance (Ω max.) | Rated ripple current (mA rms) | Case | Casing symbol | Impedance (Ω max.) | Rated ripple current (mA rms) | | | | | | | | |
| 150 | | - | - | - | - | - | - | - | - | - | - | - | - | - | - | - | - | - | - | - | - | - | | | | | | | |
| 220 | | - | - | - | - | - | - | - | - | 8×10 | G10 | 0.20 | 450 | 8×10.5 | GA5 | 0.17 | 450 | 8×10.5 | GA5 | 0.17 | 450 | 10×10 | H10 | 0.10 | 670 | 10×10 | H10 | 0.10 | 670 |
| 330 | | - | - | - | - | 8×10.5 | GA5 | 0.17 | 450 | 8×10.5 | GA5 | 0.17 | 450 | 8×10.5 | GA5 | 0.17 | 450 | 8×10.5 | GA5 | 0.17 | 450 | 10×10.5 | HA5 | 0.090 | 670 | 10×10.5 | HA5 | 0.090 | 670 |
| 470 | | 8×10.5 | GA5 | 0.17 | 450 | 8×10.5 | GA5 | 0.17 | 450 | 8×10.5 | GA5 | 0.17 | 450 | 10×10.5 | HA5 | 0.090 | 670 | 10×10.5 | HA5 | 0.090 | 670 | 12.5×13.5 | IE | 0.060 | 1100 | 12.5×13.5 | IE | 0.060 | 1100 |
| 680 | | 8×10.5 | GA5 | 0.17 | 450 | 10×10 | H10 | 0.10 | 670 | 10×10 | H10 | 0.10 | 670 | 10×10 | H10 | 0.10 | 670 | 10×10 | H10 | 0.10 | 670 | 16×16.5 | JH | 0.046 | 1540 | 16×16.5 | JH | 0.046 | 1540 |
| 1000 | | 8×10.5 | GA5 | 0.17 | 450 | 10×10 | H10 | 0.10 | 670 | 10×10 | H10 | 0.10 | 670 | 12.5×13.5 | IE | 0.060 | 1100 | 12.5×13.5 | IE | 0.060 | 1100 | 12.5×13.5 | IE | 0.060 | 1100 | 12.5×13.5 | IE | 0.060 | 1100 |
| 1500 | | 10×10.5 | HA5 | 0.090 | 670 | 12.5×13.5 | IE | 0.060 | 1100 | 12.5×13.5 | IE | 0.060 | 1100 | 16×16.5 | JH | 0.046 | 1540 | 16×16.5 | JH | 0.046 | 1540 | 16×16.5 | JH | 0.046 | 1540 | 16×16.5 | JH | 0.046 | 1540 |
| 2200 | | 12.5×13.5 | IE | 0.060 | 1100 | 16×16.5 | JH | 0.046 | 1540 | 16×16.5 | JH | 0.046 | 1540 | 16×16.5 | JH | 0.046 | 1540 | 16×16.5 | JH | 0.046 | 1540 | 16×16.5 | JH | 0.046 | 1540 | 16×16.5 | JH | 0.046 | 1540 |
| 3300 | | 16×16.5 | JH | 0.046 | 1540 | 16×16.5 | JH | 0.046 | 1540 | 16×16.5 | JH | 0.046 | 1540 | 16×16.5 | JH | 0.046 | 1540 | 16×16.5 | JH | 0.046 | 1540 | 16×16.5 | JH | 0.046 | 1540 | 16×16.5 | JH | 0.046 | 1540 |
| 4700 | | 16×16.5 | JH | 0.046 | 1540 | 16×16.5 | JH | 0.046 | 1540 | 16×16.5 | JH | 0.046 | 1540 | 16×16.5 | JH | 0.046 | 1540 | 16×16.5 | JH | 0.046 | 1540 | 16×16.5 | JH | 0.046 | 1540 | 16×16.5 | JH | 0.046 | 1540 |
| 6800 | | 18×21.5 | KM | 0.038 | 1960 | 18×21.5 | KM | 0.038 | 1960 | 18×21.5 | KM | 0.038 | 1960 | 18×21.5 | KM | 0.038 | 1960 | 18×21.5 | KM | 0.038 | 1960 | 18×21.5 | KM | 0.038 | 1960 | 18×21.5 | KM | 0.038 | 1960 |
| 8200 | | 18×21.5 | KM | 0.038 | 1960 | 18×21.5 | KM | 0.038 | 1960 | 18×21.5 | KM | 0.038 | 1960 | 18×21.5 | KM | 0.038 | 1960 | 18×21.5 | KM | 0.038 | 1960 | 18×21.5 | KM | 0.038 | 1960 | 18×21.5 | KM | 0.038 | 1960 |

(Note) Rated ripple current : 105°C , 100kHz, Impedance : 20°C , 100kHz

NOTE : Design, Specifications are subject to change without notice. It is recommended that you shall obtain technical specifications from ELNA to ensure that the component is suitable for your use.

Chip Type 105°C Use, Low Z, Long Life, For Vibration Capacitors

GREEN CAP SMD Vibration Resistance Low Z 105°C 5000hours Anti-cleaning solvent

- Compatible with surface mounting.
- For Vibration resistance. (30G guaranteed)
- Supplied with carrier taping.
- Guarantees 5000 hours at 105°C.

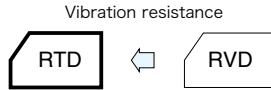

Marking color : Black print

Specifications

| Item | Performance | | | | | | | | | | |
|--|--|---|------|------|------|------|-----|------|------|------|---|
| Category temperature range (°C) | -55 to +105 | | | | | | | | | | |
| Tolerance at rated capacitance (%) | ±20 (20°C, 120Hz) | | | | | | | | | | |
| Leakage current (µA) | Less than 0.01CV or 3 whichever is larger (after 2 minutes) C : Rated capacitance (µF) , V : Rated voltage (V) (20°C) | | | | | | | | | | |
| Tangent of loss angle (tanδ) | Rated voltage (V) | 6.3 | 10 | 16 | 25 | 35 | 50 | 63 | 80 | 100 | |
| | tanδ (max.) | 0.26 | 0.19 | 0.16 | 0.14 | 0.12 | 0.1 | 0.08 | 0.08 | 0.07 | |
| 0.02 is added to every 1000µF increase over 1000µF (20°C, 120Hz) | | | | | | | | | | | |
| Characteristics at high and low temperature | Rated voltage (V) | 6.3 | 10 | 16 | 25 | 35 | 50 | 63 | 80 | 100 | |
| | Impedance ratio (max.) | Z-25°C/Z+20°C | 2 | 2 | 2 | 2 | 2 | 2 | 2 | 2 | 2 |
| | | Z-40°C/Z+20°C | 3 | 3 | 3 | 3 | 3 | 3 | 3 | 3 | 3 |
| Z-55°C/Z+20°C | | 8 | 4 | 4 | 3 | 3 | 3 | 3 | 3 | 3 | |
| (120Hz) | | | | | | | | | | | |
| Endurance (105°C) | Test time | 5000 hours | | | | | | | | | |
| | Leakage current | The initial specified value or less | | | | | | | | | |
| | Percentage of capacitance change | Within ±30% of initial value | | | | | | | | | |
| | Tangent of loss angle | 300% or less of the initial specified value | | | | | | | | | |
| Shelf life (105°C) | Test time : 1000 hours ; other items are the same as those for the endurance. Voltage application treatment : According to JIS C5101-1 | | | | | | | | | | |
| Applicable standards | JIS C5101-1 1998, -18 1999 (IEC 60384-1 1992, -18 1993) | | | | | | | | | | |

Outline Drawing

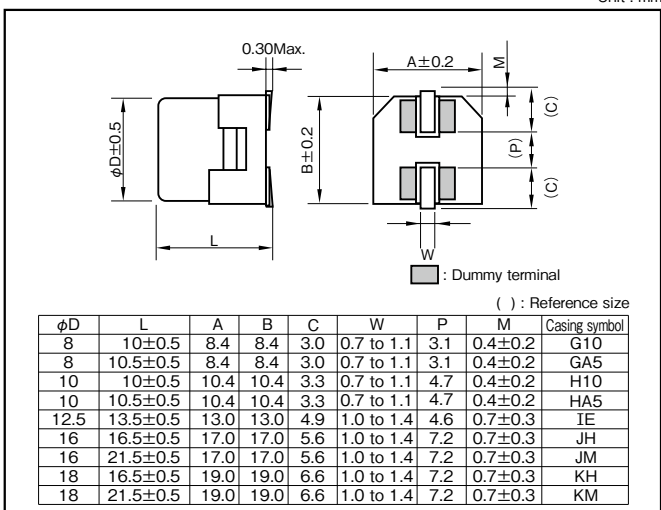

Coefficient of Frequency for Rated Ripple Current

| Frequency (Hz) | 120 | 1k | 10k | 100k |
|-------------------|------|------|------|------|
| Rated voltage (V) | 120 | 1k | 10k | 100k |
| 6.3 to 100 | 0.50 | 0.75 | 0.90 | 1 |

Part numbering system

φ8, φ10 (6.3V1500µF)

| | | | | | | | |
|-------------|----------------------|--------------------------|------------------------------|---------------|---------------|----|--|
| RTD | 6 | V | 152 | M | HA5 | SU | |
| Series code | Rated voltage symbol | Rated capacitance symbol | Capacitance tolerance symbol | Casing symbol | Taping symbol | | |

φ12.5 or more (6.3V2200µF)

| | | | | | | | |
|-------------|----------------------|--------------------------|------------------------------|---------------|---------------|---|--|
| RTD | 6 | V | 222 | M | IE | T | |
| Series code | Rated voltage symbol | Rated capacitance symbol | Capacitance tolerance symbol | Casing symbol | Taping symbol | | |

- Soldering conditions are described on page 13.
- Land pattern size are described on page 11.
- The taping specifications are described on page 14.

Standard Ratings

| Rated voltage (V) | Item | 6.3 | | | | 10 | | | | 16 | | | | 25 | | | | 35 | | | | | | |
|-------------------|-----------|----------------|---------------|--------------------|--------------------------------|----------------|---------------|--------------------|--------------------------------|----------------|---------------|--------------------|--------------------------------|----------------|---------------|--------------------|--------------------------------|----------------|---------------|--------------------|--------------------------------|-----|-------|------|
| | | Case φD×L (mm) | Casing symbol | Impedance (Ω max.) | Rated ripple current (mA Arms) | Case φD×L (mm) | Casing symbol | Impedance (Ω max.) | Rated ripple current (mA Arms) | Case φD×L (mm) | Casing symbol | Impedance (Ω max.) | Rated ripple current (mA Arms) | Case φD×L (mm) | Casing symbol | Impedance (Ω max.) | Rated ripple current (mA Arms) | Case φD×L (mm) | Casing symbol | Impedance (Ω max.) | Rated ripple current (mA Arms) | | | |
| 100 | | | | | | | | | | | | | | | | | | | | | | | | |
| 220 | | | | | | | | | | | | | | | | | | | | | | | | |
| 330 | | | | | | | | | | | | | | | | | | | | | | | | |
| 470 | 8×10.5 | GA5 | 0.16 | 600 | 8×10.5 | GA5 | 0.16 | 600 | 8×10.5 | GA5 | 0.16 | 600 | 8×10.5 | GA5 | 0.16 | 600 | 10×10.5 | HA5 | 0.090 | 850 | 10×10.5 | HA5 | 0.090 | 850 |
| 680 | 8×10.5 | GA5 | 0.16 | 600 | 10×10.5 | HA5 | 0.090 | 850 | 10×10.5 | HA5 | 0.090 | 850 | 12.5×13.5 | IE | 0.054 | 1160 | 12.5×13.5 | IE | 0.054 | 1160 | 12.5×13.5 | IE | 0.054 | 1160 |
| 1000 | 8×10.5 | GA5 | 0.16 | 600 | 10×10.5 | HA5 | 0.090 | 850 | 12.5×13.5 | IE | 0.054 | 1160 | 12.5×13.5 | IE | 0.054 | 1160 | 16×16.5 | JH | 0.044 | 1620 | 16×16.5 | JH | 0.044 | 1620 |
| 1500 | 10×10.5 | HA5 | 0.090 | 850 | 12.5×13.5 | IE | 0.054 | 1160 | 12.5×13.5 | IE | 0.054 | 1160 | 16×16.5 | JH | 0.044 | 1620 | 18×16.5 | KH | 0.040 | 1840 | 18×16.5 | KH | 0.040 | 1840 |
| 2200 | 12.5×13.5 | IE | 0.054 | 1160 | 12.5×13.5 | IE | 0.060 | 1160 | 16×16.5 | JH | 0.044 | 1620 | 16×16.5 | JH | 0.044 | 1620 | 18×16.5 | KH | 0.040 | 1840 | 18×21.5 | KM | 0.036 | 2080 |
| 3300 | 16×16.5 | JH | 0.044 | 1620 | 16×16.5 | JH | 0.044 | 1620 | 16×21.5 | JM | 0.038 | 1920 | 18×21.5 | KM | 0.036 | 2080 | | | | | | | | |
| 4700 | 18×16.5 | KH | 0.040 | 1840 | 18×21.5 | KM | 0.036 | 2080 | 18×21.5 | KM | 0.036 | 2080 | | | | | | | | | | | | |
| 6800 | 18×16.5 | KH | 0.040 | 1840 | | | | | | | | | | | | | | | | | | | | |
| 8200 | 18×21.5 | KM | 0.036 | 2080 | | | | | | | | | | | | | | | | | | | | |

| Rated voltage (V) | Item | 50 | | | | 63 | | | | 80 | | | | 100 | | | |
|-------------------|-----------|----------------|---------------|--------------------|--------------------------------|----------------|---------------|--------------------|--------------------------------|----------------|---------------|--------------------|--------------------------------|----------------|---------------|--------------------|--------------------------------|
| | | Case φD×L (mm) | Casing symbol | Impedance (Ω max.) | Rated ripple current (mA Arms) | Case φD×L (mm) | Casing symbol | Impedance (Ω max.) | Rated ripple current (mA Arms) | Case φD×L (mm) | Casing symbol | Impedance (Ω max.) | Rated ripple current (mA Arms) | Case φD×L (mm) | Casing symbol | Impedance (Ω max.) | Rated ripple current (mA Arms) |
| 100 | 8×10.5 | GA5 | 0.32 | 350 | 12.5×13.5 | IE | 0.16 | 600 | 12.5×13.5 | IE | 0.18 | 550 | 16×16.5 | JH | 0.17 | 700 | |
| 220 | 10×10.5 | HA5 | 0.18 | 700 | 12.5×13.5 | IE | 0.16 | 600 | 16×16.5 | JH | 0.16 | 720 | 18×16.5 | KH | 0.15 | 800 | |
| 330 | 12.5×13.5 | IE | 0.12 | 900 | 16×16.5 | JH | 0.14 | 800 | 18×16.5 | KH | 0.13 | 830 | 18×21.5 | KM | 0.13 | 940 | |
| 470 | 16×16.5 | JH | 0.080 | 1000 | 18×16.5 | KH | 0.12 | 900 | 18×21.5 | KM | 0.11 | 1000 | | | | | |
| 680 | 16×16.5 | JH | 0.080 | 1000 | 18×21.5 | KM | 0.10 | 1050 | | | | | | | | | |
| 1000 | 18×16.5 | KH | 0.076 | 1100 | | | | | | | | | | | | | |

(Note) Rated ripple current : 105°C , 100kHz, Impedance : 20°C , 100kHz

Chip Type 125°C Use, Low ESR, For Vibration Capacitors

GREEN CAP SMD Vibration Resistance Low ESR 125°C 2000hours Anti-cleaning solvent

- Compatible with surface mounting.
- For Vibration resistance. (30G guaranteed)
- Supplied with carrier taping.
- Guarantees 2000 hours at 125°C. (φ12.5 or more : 5000h)

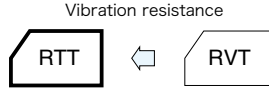

Marking color : Black print

Specifications

| Item | Performance | | | | | | | | | | |
|---|--|---|------|------|------|------|------|------|------|----|-----|
| Category temperature range (°C) | -40 to +125 | | | | | | | | | | |
| Tolerance at rated capacitance (%) | ±20 (20°C,120Hz) | | | | | | | | | | |
| Leakage current (μA) | Less than 0.01CV or 3 whichever is larger (after 2 minutes) C : Rated capacitance (μF) , V : Rated voltage (V) (20°C) | | | | | | | | | | |
| Tangent of loss angle (tanδ) | Rated voltage (V) | 10 | 16 | 25 | 35 | 50 | 63 | 80 | 100 | | |
| | Tangent of loss angle | 0.24 | 0.20 | 0.16 | 0.14 | 0.14 | 0.12 | 0.12 | 0.10 | | |
| 0.02 is added to every 1000μF increase over 1000μF (20°C,120Hz) | | | | | | | | | | | |
| Characteristics at high and low temperature | Impedance ratio (max.) | Rated voltage (V) | | 10 | 16 | 25 | 35 | 50 | 63 | 80 | 100 |
| | | Z-25°C/Z+20°C | 3 | 2 | 2 | 2 | 2 | 2 | 2 | 2 | 2 |
| | | Z-40°C/Z+20°C | | 4 | 3 | 3 | 3 | 3 | 3 | 3 | 3 |
| (120Hz) | | | | | | | | | | | |
| Endurance (125°C) | Test time | 2000 hours (φ12.5 or more : 5000h) | | | | | | | | | |
| | Leakage current | The initial specified value or less | | | | | | | | | |
| | Percentage of capacitance change | Within ±30% of initial value | | | | | | | | | |
| | Tangent of loss angle | 300% or less of the initial specified value | | | | | | | | | |
| Shelf life (125°C) | Test time : 1000 hours ; other items are the same as those for the endurance. Voltage application treatment : According to JIS C5101-1 | | | | | | | | | | |
| Applicable standards | JIS C5101-1 1998, -18 1999 (IEC 60384-1 1992, -18 1993) | | | | | | | | | | |

Outline Drawing

Unit : mm

| φD | L | A | B | C | W | P | M | Casing symbol |
|------|----------|------|------|-----|------------|-----|---------|---------------|
| 8 | 10±0.5 | 8.4 | 8.4 | 3.0 | 0.7 to 1.1 | 3.1 | 0.4±0.2 | G10 |
| 10 | 10±0.5 | 10.4 | 10.4 | 3.3 | 0.7 to 1.1 | 4.7 | 0.4±0.2 | H10 |
| 12.5 | 13.5±0.5 | 13.0 | 13.0 | 4.9 | 1.0 to 1.4 | 4.6 | 0.7±0.3 | IE |
| 16 | 16.5±0.5 | 17.0 | 17.0 | 5.6 | 1.0 to 1.4 | 7.2 | 0.7±0.3 | JH |
| 16 | 21.5±0.5 | 17.0 | 17.0 | 5.6 | 1.0 to 1.4 | 7.2 | 0.7±0.3 | JM |
| 18 | 16.5±0.5 | 19.0 | 19.0 | 6.6 | 1.0 to 1.4 | 7.2 | 0.7±0.3 | KH |
| 18 | 21.5±0.5 | 19.0 | 19.0 | 6.6 | 1.0 to 1.4 | 7.2 | 0.7±0.3 | KM |

() : Reference size

Coefficient of Frequency for Rated Ripple Current

| Frequency (Hz) | 120 | 1k | 10k | 100k |
|-------------------|------|------|------|------|
| Rated voltage (V) | | | | |
| 10 to 100 | 0.77 | 0.88 | 0.96 | 1 |

Part numbering system

φ8, φ10 (35V100μF)

RTT — 35 V 101 M H10 SU — □

Series code Rated voltage symbol Rated capacitance symbol Capacitance tolerance symbol Casing symbol Taping symbol

φ12.5 or more (35V1000μF)

RTT — 35 V 102 M KM T — □

Series code Rated voltage symbol Rated capacitance symbol Capacitance tolerance symbol Casing symbol Taping symbol

- Soldering conditions are described on page 13.
- Land pattern size are described on page 11.
- The taping specifications are described on page 14.

Standard Ratings

| Rated voltage (V) | 10 | | | | 16 | | | | 25 | | | | 35 | | | | 50 | | | |
|------------------------|-----------|---------------|-------|----------------------|-----------|---------------|-------|----------------------|-----------|---------------|-------|----------------------|-----------|---------------|-------|----------------------|-----------|---------------|-------|----------------------|
| | Case | ESR (Ω max.) | | Rated ripple current | Case | ESR (Ω max.) | | Rated ripple current | Case | ESR (Ω max.) | | Rated ripple current | Case | ESR (Ω max.) | | Rated ripple current | Case | ESR (Ω max.) | | Rated ripple current |
| Rated capacitance (μF) | φD×L (mm) | 20°C | -40°C | (mArms) | φD×L (mm) | 20°C | -40°C | (mArms) | φD×L (mm) | 20°C | -40°C | (mArms) | φD×L (mm) | 20°C | -40°C | (mArms) | φD×L (mm) | 20°C | -40°C | (mArms) |
| 100 | — | — | — | — | — | — | — | — | — | — | — | — | 8×10 | 0.25 | 2.5 | 340 | 10×10 | 0.50 | 7.5 | 250 |
| 220 | — | — | — | — | 8×10 | 0.25 | 2.5 | 340 | 8×10 | 0.25 | 2.5 | 340 | 8×10 | 0.25 | 2.5 | 340 | 12.5×13.5 | 0.18 | 2.7 | 550 |
| 330 | — | — | — | — | 10×10 | 0.15 | 1.5 | 500 | 10×10 | 0.15 | 1.5 | 500 | 10×10 | 0.15 | 1.5 | 500 | 12.5×13.5 | 0.18 | 2.7 | 550 |
| 470 | — | — | — | — | 10×10 | 0.15 | 1.5 | 500 | 10×10 | 0.15 | 1.5 | 500 | 12.5×13.5 | 0.086 | 1.29 | 750 | 16×16.5 | 0.12 | 1.8 | 850 |
| 680 | — | — | — | — | 10×10 | 0.15 | 1.5 | 500 | 12.5×13.5 | 0.086 | 1.29 | 750 | 16×16.5 | 0.060 | 0.90 | 1000 | 18×16.5 | 0.10 | 1.5 | 920 |
| 1000 | — | — | — | — | 12.5×13.5 | 0.086 | 1.29 | 750 | 12.5×13.5 | 0.086 | 1.29 | 750 | 16×16.5 | 0.060 | 0.90 | 1000 | — | — | — | — |
| 2200 | — | — | — | — | 16×16.5 | 0.050 | 0.75 | 1200 | 16×16.5 | 0.050 | 0.75 | 1200 | 18×16.5 | 0.050 | 0.75 | 1200 | — | — | — | — |
| 3300 | — | — | — | — | 18×16.5 | 0.050 | 0.75 | 1200 | 18×16.5 | 0.050 | 0.75 | 1200 | 18×21.5 | 0.042 | 0.63 | 1550 | — | — | — | — |
| 4700 | — | — | — | — | 18×21.5 | 0.042 | 0.63 | 1550 | — | — | — | — | — | — | — | — | — | — | — | — |

| Rated voltage (V) | 63 | | | 80 | | | 100 | | | | | |
|------------------------|-----------|---------------|-------|----------------------|-----------|---------------|-------|----------------------|-----------|---------------|-------|----------------------|
| | Case | ESR (Ω max.) | | Rated ripple current | Case | ESR (Ω max.) | | Rated ripple current | Case | ESR (Ω max.) | | Rated ripple current |
| Rated capacitance (μF) | φD×L (mm) | 20°C | -40°C | (mArms) | φD×L (mm) | 20°C | -40°C | (mArms) | φD×L (mm) | 20°C | -40°C | (mArms) |
| 47 | — | — | — | — | — | — | — | — | 12.5×13.5 | 0.32 | 4.8 | 300 |
| 100 | 12.5×13.5 | 0.25 | 3.75 | 400 | 16 × 16.5 | 0.24 | 3.6 | 480 | 16×16.5 | 0.24 | 3.6 | 480 |
| 220 | 16×16.5 | 0.22 | 3.3 | 500 | 16 × 21.5 | 0.18 | 2.7 | 600 | 18×21.5 | 0.16 | 2.4 | 700 |
| 330 | 16×16.5 | 0.22 | 3.3 | 500 | 18 × 21.5 | 0.12 | 1.8 | 1000 | — | — | — | — |
| 470 | 16×21.5 | 0.16 | 2.4 | 650 | — | — | — | — | — | — | — | — |

(Note) Rated ripple current : 105°C , 100kHz, ESR : 100kHz

NOTE : Design, Specifications are subject to change without notice. It is recommended that you shall obtain technical specifications from ELNA to ensure that the component is suitable for your use.

Horizontal Type, 125°C Use, For Vibration Capacitors

| | | | |
|-----|----------------------|-----------------|-----------------------|
| SMD | Vibration Resistance | 125°C 1000hours | Anti-cleaning solvent |
|-----|----------------------|-----------------|-----------------------|

- 125°C high temperature surface mount.
- Highly resistant to vibration.
- Available in horizontal configurations only.
- Supplied with carrier taping.
- Guarantees 1000 hours at 125°C.

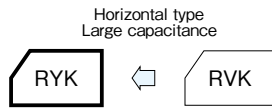

Marking color : White print on a black case

Specifications

| Item | Performance | | | | | | | | |
|---|--|---|------|------|------|------|------|------|---|
| Category temperature range (°C) | -40 to +125 | | | | | | | | |
| Tolerance at rated capacitance (%) | ±20 (20°C, 120Hz) | | | | | | | | |
| Leakage current (µA) | Less than 0.02CV (after 2 minutes) C : Rated capacitance (µF) ; V : Rated voltage (V) (20°C) | | | | | | | | |
| Tangent of loss angle (tanδ) | Rated voltage (V) | 6.3 | 10 | 16 | 25 | 35 | 50 | 63 | |
| | tanδ (max.) | 0.30 | 0.28 | 0.26 | 0.24 | 0.20 | 0.19 | 0.18 | |
| Characteristics at high and low temperature | Rated voltage (V) | 6.3 | 10 | 16 | 25 | 35 | 50 | 63 | |
| | Impedance ratio (max.) | Z-25°C/Z+20°C | 3 | 3 | 3 | 3 | 3 | 3 | 3 |
| | | Z-40°C/Z+20°C | 5 | 5 | 5 | 5 | 5 | 5 | 5 |
| Endurance (125°C) (Applied ripple current) | Test time | 1000 hours | | | | | | | |
| | Leakage current | The initial specified value or less | | | | | | | |
| | Percentage of capacitance change | Within ±30% of initial value | | | | | | | |
| | Tangent of the loss angle | 300% or less of the initial specified value | | | | | | | |
| Shelf life (125°C) | Test time | 500 hours | | | | | | | |
| | Leakage current | The initial specified value or less | | | | | | | |
| | Percentage of capacitance change | Within ±20% of initial value | | | | | | | |
| | Tangent of the loss angle | 200% or less of the initial specified value | | | | | | | |
| Applicable standards | Pretreatment performed JIS C5101-1 1998, -18 1999 (IEC 60384-1 1992, -18 1993) | | | | | | | | |

Outline Drawing

Unit : mm

Case Size : 9.5×24.0
■ 8 terminals type : Casing symbol G5T

| Case size | W | L0 | L | L1 | H | H0 | H1 | F |
|-----------|---------|------|--------|--------|---------|---------|---------|---------|
| 9.5×24 | 9.5±0.5 | 24±1 | 21±0.5 | 22±0.5 | 9.3±0.5 | 9.3±0.5 | 9.1±0.3 | 3.5±0.5 |

Case Size : 9.5×19.0
■ 6 terminals type : Casing symbol G4

| Case size | W | L0 | L | L1 | H | H0 | H1 | F |
|-----------|---------|------|--------|--------|---------|---------|---------|---------|
| 9.5×19 | 9.5±0.5 | 19±1 | 16±0.5 | 17±0.5 | 9.3±0.5 | 9.3±0.5 | 9.1±0.3 | 3.5±0.5 |

• Soldering conditions are described on page 11. • Land pattern size are described on page 12. • The taping specifications are described on page 13.

Part numbering system (example: 10V560µF)

| | | | | | | | | | |
|-------------|---|----------------------|---|--------------------------|------------------------------|---------------|---|---|----------------------|
| RYK | — | 10 | V | 561 | M | G5T | T | — | FL |
| Series code | | Rated voltage symbol | | Rated capacitance symbol | Capacitance tolerance symbol | Casing symbol | | | Tray polarity symbol |

Coefficient of Frequency for Rated Ripple Current

| Frequency (Hz) | 120 | 1k | 10k | 100k |
|-------------------|------|------|------|------|
| Rated voltage (V) | | | | |
| 10 to 63 | 0.77 | 0.88 | 0.96 | 1 |

Standard Ratings

| Rated capacitance (µF) | Item | 6.3 | | | 10 | | | 16 | | | 25 | | | 35 | | | 50 | | | 63 | | |
|------------------------|----------|---------------|--------------------|-------------------------------|---------------|--------------------|-------------------------------|---------------|--------------------|-------------------------------|---------------|--------------------|-------------------------------|---------------|--------------------|-------------------------------|---------------|--------------------|-------------------------------|---------------|--------------------|-------------------------------|
| | | Case W×L (mm) | Impedance (Ω max.) | Rated ripple current (mA rms) | Case W×L (mm) | Impedance (Ω max.) | Rated ripple current (mA rms) | Case W×L (mm) | Impedance (Ω max.) | Rated ripple current (mA rms) | Case W×L (mm) | Impedance (Ω max.) | Rated ripple current (mA rms) | Case W×L (mm) | Impedance (Ω max.) | Rated ripple current (mA rms) | Case W×L (mm) | Impedance (Ω max.) | Rated ripple current (mA rms) | Case W×L (mm) | Impedance (Ω max.) | Rated ripple current (mA rms) |
| 56 | — | — | — | — | — | — | — | — | — | — | — | — | — | — | — | — | — | — | — | — | — | — |
| 82 | — | — | — | — | — | — | — | — | — | — | — | — | — | — | — | — | — | — | — | — | — | — |
| 100 | — | — | — | — | — | — | — | — | — | — | — | — | — | — | — | — | — | — | — | — | — | — |
| 220 | — | — | — | — | — | — | — | — | — | — | — | — | — | — | — | — | — | — | — | — | — | — |
| 270 | — | — | — | — | — | — | — | — | — | — | — | — | — | — | — | — | — | — | — | — | — | — |
| 470 | — | — | — | — | — | — | — | — | — | — | — | — | — | — | — | — | — | — | — | — | — | — |
| 560 | 9.5×19.0 | 0.40 | 232 | 9.5×24.0 | 0.30 | 302 | — | — | — | — | — | — | — | — | — | — | — | — | — | — | — | — |
| 820 | 9.5×24.0 | 0.30 | 302 | — | — | — | — | — | — | — | — | — | — | — | — | — | — | — | — | — | — | — |

(Note) Rated ripple current : 125°C, 100kHz ; Impedance : 20°C, 100kHz

Miniature Aluminum Electrolytic Capacitors

5mm L, Standard Capacitors

GREEN CAP

- Diameters from $\phi 3$ to $\phi 8$ mm and a height of 5mm.

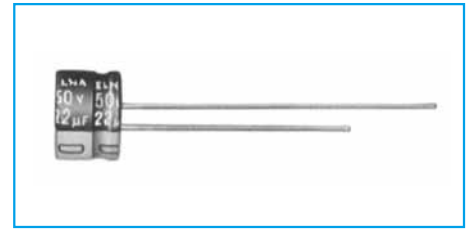

Marking color : White print on a blue sleeve ($\phi 3$: black sleeve)

Specifications

| Item | Performance | | | | | | | |
|--|--|---|------|------|------|------|------|------|
| Category temperature range (°C) | -40 to +85 | | | | | | | |
| Tolerance at rated capacitance (%) | ± 20 (20°C, 120Hz) | | | | | | | |
| Leakage current (μA) | Less than 0.01CV or 3 whichever is larger (after 2 minutes) C : Rated capacitance (μF); V : Rated voltage (V) (20°C) | | | | | | | |
| Tangent of loss angle (tan δ) | Rated voltage (V) | | | | | | | |
| | | 4 | 6.3 | 10 | 16 | 25 | 35 | 50 |
| tan δ (max.) | $\phi 3$ to $\phi 6.3$ | 0.35 | 0.24 | 0.20 | 0.16 | 0.14 | 0.12 | 0.10 |
| | $\phi 8$ | 0.39 | 0.28 | 0.24 | 0.16 | 0.14 | 0.12 | 0.10 |
| Characteristics at high and low temperature | Rated voltage (V) | | | | | | | |
| | | 4 | 6.3 | 10 | 16 | 25 | 35 | 50 |
| Impedance ratio (max.) | Z-25°C/Z+20°C | 6 | 4 | 3 | 2 | 2 | 2 | 2 |
| | Z-40°C/Z+20°C | 16 | 10 | 8 | 6 | 4 | 4 | 4 |
| Endurance (85°C) (Applied ripple current) | Test time | 1000 hours | | | | | | |
| | Leakage current | The initial specified value or less | | | | | | |
| | Percentage of capacitance change | Within $\pm 20\%$ of initial value | | | | | | |
| | Tangent of the loss angle | 200% or less of the initial specified value | | | | | | |
| Shelf life (85°C) | Test time : 1000 hours ; other items are the same as those for the endurance. Voltage application treatment : According to JIS C5101-1 | | | | | | | |
| Applicable standards | JIS C5101-1, -4 1998 (IEC 60384-1 1992, -4 1985) | | | | | | | |

Outline Drawing

Unit : mm

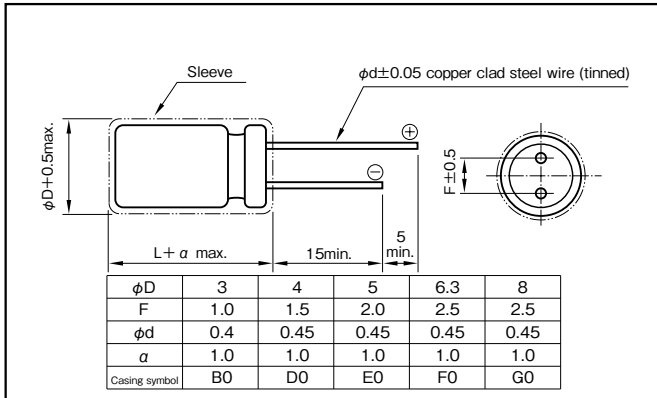

Coefficient of Frequency for Rated Ripple Current

| Rated voltage (V) | Frequency (Hz) | | | |
|-------------------|----------------|-----|-----|------------|
| | 50 · 60 | 120 | 1k | 10k · 100k |
| 4 to 16 | 0.8 | 1 | 1.1 | 1.2 |
| 25 to 35 | 0.8 | 1 | 1.5 | 1.7 |
| 50 | 0.8 | 1 | 1.6 | 1.9 |

Part numbering system (example : 6.3V100 μF)

| | | | | | | | | | | |
|-------------|---|----------------------|---|--------------------------|------------------------------|---------------|-------------------|---|---|-------------------------|
| RC3 | — | 6 | V | 101 | M | F0 | # | * | — | □ |
| Series code | | Rated voltage symbol | | Rated capacitance symbol | Capacitance tolerance symbol | Casing symbol | Additional symbol | | | Taping (Forming) symbol |

*Should add "2", when size is $\phi 3 \times 5L$.

Standard Ratings

| Rated capacitance (μF) | 4 | | 6.3 | | 10 | | 16 | | 25 | | 35 | | 50 | |
|-------------------------------|-------|-------------------------------|-------|-------------------------------|-------|-------------------------------|-------|-------------------------------|-------|-------------------------------|-------|-------------------------------|-------|-------------------------------|
| | Case | Rated ripple current (mA rms) | Case | Rated ripple current (mA rms) | Case | Rated ripple current (mA rms) | Case | Rated ripple current (mA rms) | Case | Rated ripple current (mA rms) | Case | Rated ripple current (mA rms) | Case | Rated ripple current (mA rms) |
| 0.22 | — | — | — | — | — | — | — | — | — | — | — | — | 3×5 | 4 |
| 0.33 | — | — | — | — | — | — | — | — | — | — | — | — | 3×5 | 5 |
| | — | — | — | — | — | — | — | — | — | — | — | — | 4×5 | 6 |
| 0.47 | — | — | — | — | — | — | — | — | — | — | — | — | 3×5 | 6 |
| | — | — | — | — | — | — | — | — | — | — | — | — | 4×5 | 7 |
| 1 | — | — | — | — | — | — | — | — | — | — | — | — | 3×5 | 8 |
| | — | — | — | — | — | — | — | — | — | — | — | — | 4×5 | 10 |
| 2.2 | — | — | — | — | — | — | — | — | — | — | — | 3×5 | 11 | |
| | — | — | — | — | — | — | — | — | — | — | — | 4×5 | 14 | |
| 3.3 | — | — | — | — | — | — | — | — | 3×5 | 13 | 4×5 | 17 | 4×5 | 18 |
| | — | — | — | — | — | — | — | — | 4×5 | 15 | | | | |
| 4.7 | — | — | — | — | — | — | — | — | 3×5 | 14 | 4×5 | 18 | 4×5 | 20 |
| | — | — | — | — | — | — | — | — | 4×5 | 17 | | | | |
| 10 | — | — | 3×5 | 17 | 4×5 | 22 | 4×5 | 25 | 5×5 | 30 | 5×5 | 30 | 6.3×5 | 40 |
| | — | — | 4×5 | 20 | | | | | | | | | | |
| 22 | 3×5 | 21 | 4×5 | 30 | 5×5 | 35 | 5×5 | 40 | 6.3×5 | 50 | 6.3×5 | 55 | 8×5 | 75 |
| | 4×5 | 25 | | | | | | | | | | | | |
| 33 | 4×5 | 30 | 5×5 | 40 | 5×5 | 45 | 6.3×5 | 60 | 6.3×5 | 65 | 8×5 | 80 | 8×5 | 90 |
| 47 | 4×5 | 35 | 5×5 | 50 | 6.3×5 | 65 | 6.3×5 | 70 | 8×5 | 95 | 8×5 | 100 | — | — |
| 100 | 5×5 | 60 | 6.3×5 | 85 | 6.3×5 | 95 | 8×5 | 125 | 8×5 | 135 | — | — | — | — |
| 220 | 6.3×5 | 105 | 8×5 | 145 | 8×5 | 155 | — | — | — | — | — | — | — | — |
| 330 | 8×5 | 150 | 8×5 | 175 | — | — | — | — | — | — | — | — | — | — |
| 470 | 8×5 | 180 | — | — | — | — | — | — | — | — | — | — | — | — |

(Note) Rated ripple current : 85°C, 120Hz.

5mm L, 105°C Use Capacitors

GREEN CAP 105°C 1000hours Anti-cleaning solvent

- Diameters from $\phi 4$ to $\phi 6.3$ mm and a height of 5mm.
- Guarantees 1000 hours at 105°C.

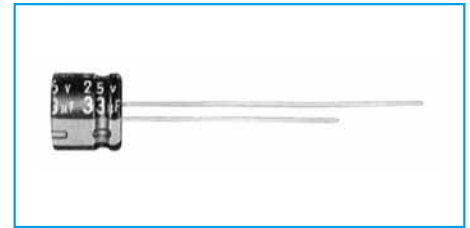
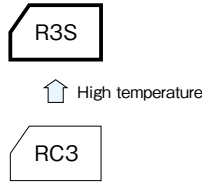

Marking color : White print on a black sleeve

Specifications

| Item | Performance | |
|---|--|--|
| Category temperature range (°C) | -55 to +105 | |
| Tolerance at rated capacitance (%) | ±20 (20°C,120Hz) | |
| Leakage current (µA) | Less than 0.01CV or 3 whichever is larger (after 2 minutes) C : Rated capacitance (µF); V : Rated voltage (V) (20°C) | |
| Tangent of loss angle (tanδ) | Rated voltage (V) | 6.3 10 16 25 35 50 |
| | tanδ (max.) | 0.28 0.24 0.20 0.14 0.12 0.10 (20°C,120Hz) |
| Characteristics at high and low temperature | Rated voltage (V) | 6.3 10 16 25 35 50 |
| | Impedance ratio (max.) | Z-25°C/Z+20°C 3 3 2 2 2 2 Z-40°C/Z+20°C 8 5 4 3 3 3 (120Hz) |
| Endurance (105°C) (Applied ripple current) | Test time | 1000 hours |
| | Leakage current | The initial specified value or less |
| | Percentage of capacitance change | Within ±20% of initial value |
| | Tangent of the loss angle | 200% or less of the initial specified value |
| Shelf life (105°C) | Test time : 1000 hours ; other items are the same as those for the endurance. Voltage application treatment : According to JIS C5101-1 | |
| Applicable standards | JIS C5101-1, -4 1998 (IEC 60384-1 1992, -4 1985) | |

Outline Drawing

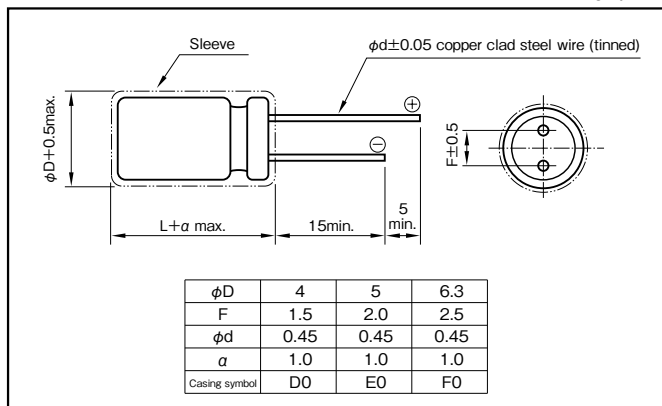

Coefficient of Frequency for Rated Ripple Current

| Rated voltage (V) | Frequency (Hz) | | | |
|-------------------|----------------|------|------|------------|
| | 50 · 60 | 120 | 1k | 10k · 100k |
| 6.3 to 16 | 0.64 | 0.80 | 0.92 | 1 |
| 25 to 35 | 0.57 | 0.71 | 0.89 | 1 |
| 50 | 0.53 | 0.67 | 0.90 | 1 |

Part numbering system (example : 16V47µF)

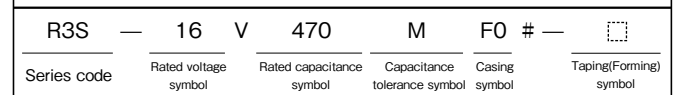

Standard Ratings

| Rated voltage (V) | 6.3 | | 10 | | 16 | | 25 | | 35 | | 50 | | |
|------------------------|------------------------|---------|------------------------|---------|------------------------|---------|------------------------|---------|------------------------|---------|------------------------|---------|----------------------|
| | Item | Case | Rated ripple current | Case | Rated ripple current | Case | Rated ripple current | Case | Rated ripple current | Case | Rated ripple current | Case | Rated ripple current |
| Rated capacitance (µF) | $\phi D \times L$ (mm) | (mArms) | $\phi D \times L$ (mm) | (mArms) | $\phi D \times L$ (mm) | (mArms) | $\phi D \times L$ (mm) | (mArms) | $\phi D \times L$ (mm) | (mArms) | $\phi D \times L$ (mm) | (mArms) | |
| 0.33 | — | — | — | — | — | — | — | — | — | — | — | 4×5 | 6 |
| 0.47 | — | — | — | — | — | — | — | — | — | — | — | 4×5 | 8 |
| 1 | — | — | — | — | — | — | — | — | — | — | — | 4×5 | 11 |
| 2.2 | — | — | — | — | — | — | — | — | — | — | — | 4×5 | 17 |
| 3.3 | — | — | — | — | — | — | — | — | — | — | — | 4×5 | 20 |
| 4.7 | — | — | — | — | — | — | — | — | — | — | — | 4×5 | 27 |
| 10 | — | — | — | — | — | — | — | — | — | — | — | 6.3×5 | 45 |
| 22 | 4×5 | 26 | 5×5 | 34 | 5×5 | 38 | 6.3×5 | 53 | 6.3×5 | 57 | — | — | — |
| 33 | 5×5 | 33 | 5×5 | 43 | 6.3×5 | 56 | 6.3×5 | 66 | — | — | — | — | — |
| 47 | 5×5 | 45 | 6.3×5 | 58 | 6.3×5 | 65 | — | — | — | — | — | — | — |
| 100 | 6.3×5 | 78 | — | — | — | — | — | — | — | — | — | — | — |

(Note) Rated ripple current : 105°C, 100kHz.

5mm L, Bipolar Capacitors

GREEN CAP

- Diameters from $\phi 4$ to $\phi 6.3$ mm and a height of 5mm.

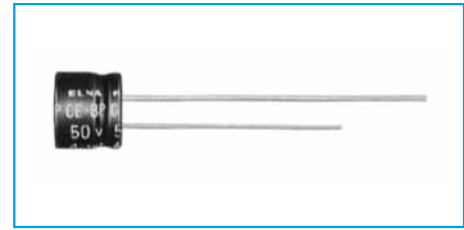
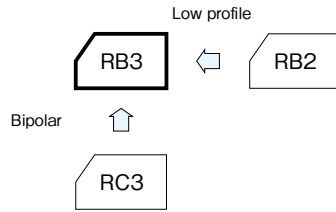

Marking color : White print on a blue sleeve

Specifications

| Item | Performance |
|---|--|
| Category temperature range (°C) | -40 to +85 |
| Tolerance at rated capacitance (%) | ± 20 (20°C, 120Hz) |
| Leakage current (μA) | Less than $0.03CV + 3$ (after 5 minutes) C : Rated capacitance (μF); V : Rated voltage (V) (20°C) |
| Tangent of loss angle ($\tan \delta$) | Rated voltage (V) |
| | $\tan \delta$ (max.) |
| Endurance (85°C) | Test time |
| | Leakage current |
| | Percentage of capacitance change |
| | Tangent of the loss angle |
| Applicable standards | JIS C5101-1, -4 1998 (IEC 60384-1 1992, -4 1985) |

Outline Drawing

Unit : mm

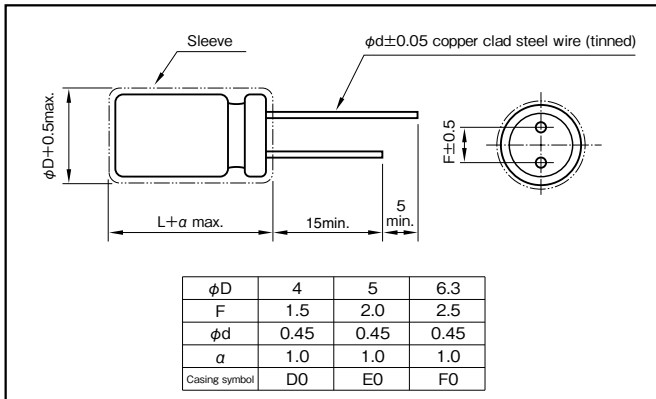

Coefficient of Frequency for Rated Ripple Current

| Rated voltage (V) | Frequency (Hz) | | | |
|-------------------|----------------|-----|-----|------------|
| | 50 - 60 | 120 | 1k | 10k - 100k |
| 6.3 to 16 | 0.8 | 1 | 1.1 | 1.2 |
| 25 to 35 | 0.8 | 1 | 1.5 | 1.7 |
| 50 | 0.8 | 1 | 1.6 | 1.9 |

Part numbering system (example : 10V47 μF)

| | | | | | | | | | |
|-------------|---|----------------------|---|--------------------------|------------------------------|---------------|---|---|------------------------|
| RB3 | — | 10 | V | 470 | M | F0 | # | — | □ |
| Series code | | Rated voltage symbol | | Rated capacitance symbol | Capacitance tolerance symbol | Casing symbol | | | Taping(Forming) symbol |

Standard Ratings

| Rated voltage (V) | 6.3 | | 10 | | 16 | | 25 | | 35 | | 50 | |
|-------------------------------|------------------------|----------------------|------------------------|----------------------|------------------------|----------------------|------------------------|----------------------|------------------------|----------------------|------------------------|----------------------|
| | Case | Rated ripple current | Case | Rated ripple current | Case | Rated ripple current | Case | Rated ripple current | Case | Rated ripple current | Case | Rated ripple current |
| Rated capacitance (μF) | $\phi D \times L$ (mm) | (mArms) | $\phi D \times L$ (mm) | (mArms) | $\phi D \times L$ (mm) | (mArms) | $\phi D \times L$ (mm) | (mArms) | $\phi D \times L$ (mm) | (mArms) | $\phi D \times L$ (mm) | (mArms) |
| 0.33 | — | — | — | — | — | — | — | — | — | — | 4×5 | 4 |
| 0.47 | — | — | — | — | — | — | — | — | — | — | 4×5 | 5 |
| 1 | — | — | — | — | — | — | — | — | — | — | 4×5 | 7 |
| 2.2 | — | — | — | — | — | — | — | — | 4×5 | 11 | 5×5 | 14 |
| 3.3 | — | — | — | — | — | — | 4×5 | 13 | 5×5 | 17 | 6.3×5 | 20 |
| 4.7 | — | — | — | — | 4×5 | 14 | 5×5 | 21 | 6.3×5 | 24 | 6.3×5 | 24 |
| 10 | — | — | 4×5 | 18 | 5×5 | 26 | 6.3×5 | 35 | 6.3×5 | 35 | — | — |
| 22 | 5×5 | 31 | 6.3×5 | 40 | 6.3×5 | 45 | — | — | — | — | — | — |
| 33 | 6.3×5 | 45 | 6.3×5 | 49 | — | — | — | — | — | — | — | — |
| 47 | 6.3×5 | 54 | 6.3×5 | 59 | — | — | — | — | — | — | — | — |

(Note) Rated ripple current : 85°C, 120Hz.

7mm L, Standard Capacitors

GREEN CAP Anti-cleaning solvent

- Diameters from $\phi 4$ to $\phi 8$ mm and a height of 7mm.
- Guarantees 1000 hours at 85°C.

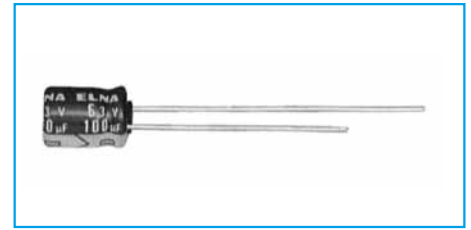
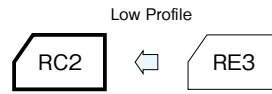

Marking color : White print on a blue sleeve

Specifications

| Item | Performance | | | | | | | | | |
|---|--|------|------|------|------|------|------|------|------|---------------|
| Category temperature range (°C) | -40 to +85 | | | | | | | | | |
| Tolerance at rated capacitance (%) | ±20 (20°C, 120Hz) | | | | | | | | | |
| Leakage current (µA) | Less than 0.01CV or 3 whichever is larger (after 2 minutes) C : Rated capacitance (µF); V : Rated voltage (V) (20°C) | | | | | | | | | |
| Tangent of loss angle (tanδ) | Rated voltage (V) | | | | | | | | | |
| | 4 | 6.3 | 10 | 16 | 25 | 35 | 50 | 63 | 100 | |
| | tanδ (max.) | | | | | | | | | |
| | 0.35 | 0.24 | 0.20 | 0.16 | 0.14 | 0.12 | 0.10 | 0.08 | 0.08 | (20°C, 120Hz) |
| Characteristics at high and low temperature | Rated voltage (V) | | | | | | | | | |
| | 4 | 6.3 | 10 | 16 | 25 | 35 | 50 | 63 | 100 | |
| Impedance ratio (max.) | Z-25°C/Z+20°C | | | | | | | | | |
| | 6 | 4 | 3 | 2 | 2 | 2 | 2 | 2 | 2 | (120Hz) |
| Endurance (85°C) (Applied ripple current) | Test time | | | | | | | | | |
| | 1000 hours | | | | | | | | | |
| Shelf life (85°C) | Leakage current | | | | | | | | | |
| | The initial specified value or less | | | | | | | | | |
| Applicable standards | Percentage of capacitance change | | | | | | | | | |
| | Within ±20% of initial value | | | | | | | | | |
| Applicable standards | Tangent of the loss angle | | | | | | | | | |
| | 200% or less of the initial specified value | | | | | | | | | |
| Applicable standards | JIS C5101-1, -4 1998 (IEC 60384-1 1992, -4 1985) | | | | | | | | | |

Outline Drawing

Unit : mm

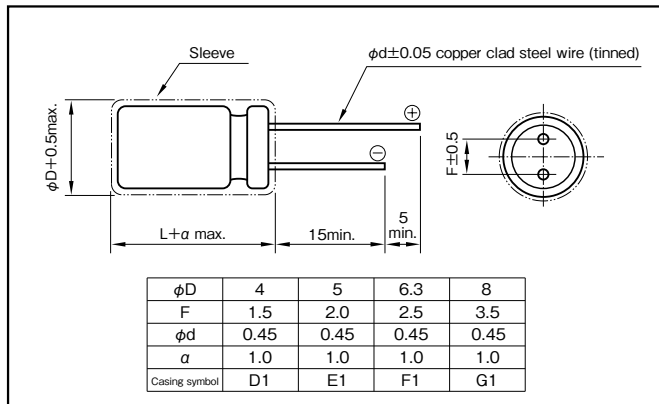

Coefficient of Frequency for Rated Ripple Current

| Rated voltage (V) | Frequency (Hz) | | | |
|-------------------|----------------|-----|-----|------------|
| | 50 · 60 | 120 | 1k | 10k · 100k |
| 4 to 16 | 0.8 | 1 | 1.1 | 1.2 |
| 25 to 35 | 0.8 | 1 | 1.5 | 1.7 |
| 50 to 100 | 0.8 | 1 | 1.6 | 1.9 |

Part numbering system (example : 10V220µF)



Standard Ratings

| Rated voltage (V) | 4 | | 6.3 | | 10 | | 16 | | 25 | | 35 | | 50 | | 63 | | 100 | |
|-------------------|-------|---------------------------|-------|---------------------------|-------|---------------------------|-------|---------------------------|-------|---------------------------|-------|---------------------------|-------|---------------------------|-------|---------------------------|-------|---------------------------|
| | Case | Rated ripple current (mA) | Case | Rated ripple current (mA) | Case | Rated ripple current (mA) | Case | Rated ripple current (mA) | Case | Rated ripple current (mA) | Case | Rated ripple current (mA) | Case | Rated ripple current (mA) | Case | Rated ripple current (mA) | Case | Rated ripple current (mA) |
| 0.33 | — | — | — | — | — | — | — | — | — | — | — | — | 4×7 | 7 | 4×7 | 7 | — | — |
| 0.47 | — | — | — | — | — | — | — | — | — | — | — | — | 4×7 | 8 | 4×7 | 8 | — | — |
| 1 | — | — | — | — | — | — | — | — | — | — | — | — | 4×7 | 10 | 4×7 | 10 | 4×7 | 12 |
| 2.2 | — | — | — | — | — | — | — | — | — | — | — | — | 4×7 | 15 | 4×7 | 15 | 5×7 | 20 |
| 3.3 | — | — | — | — | — | — | — | — | 4×7 | 15 | 4×7 | 15 | 4×7 | 20 | 4×7 | 23 | 6.3×7 | 30 |
| 4.7 | — | — | — | — | — | — | — | — | 4×7 | 20 | 4×7 | 20 | 4×7 | 24 | 5×7 | 30 | 6.3×7 | 35 |
| 10 | — | — | — | — | — | — | 4×7 | 25 | 4×7 | 30 | 4×7 | 30 | 5×7 | 40 | 6.3×7 | 50 | — | — |
| 22 | — | — | 4×7 | 35 | 4×7 | 35 | 4×7 | 40 | 5×7 | 50 | 5×7 | 55 | 6.3×7 | 70 | — | — | — | — |
| 33 | 4×7 | 35 | 4×7 | 40 | 4×7 | 45 | 5×7 | 55 | 6.3×7 | 70 | 6.3×7 | 75 | 8×7 | 100 | — | — | — | — |
| 47 | 4×7 | 40 | 4×7 | 50 | 5×7 | 60 | 5×7 | 70 | 6.3×7 | 85 | 8×7 | 110 | — | — | — | — | — | — |
| 100 | 5×7 | 70 | 5×7 | 80 | 6.3×7 | 105 | 6.3×7 | 120 | 8×7 | 145 | — | — | — | — | — | — | — | — |
| 220 | 6.3×7 | 120 | 6.3×7 | 140 | 8×7 | 185 | 8×7 | 205 | — | — | — | — | — | — | — | — | — | — |
| 330 | 8×7 | 170 | 8×7 | 205 | — | — | — | — | — | — | — | — | — | — | — | — | — | — |

(Note) Rated ripple current : 85°C, 120Hz.

7mm L, 105°C Use Capacitors

GREEN CAP 105°C 1000hours Anti-cleaning solvent

- Diameters from $\phi 4$ to $\phi 6.3$ mm and a height of 7mm.
- Guarantees 1000 hours at 105°C.



High temperature

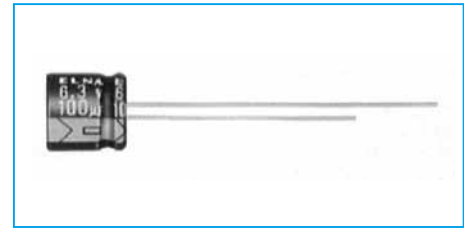
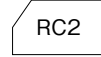

Marking color : White print on a black sleeve

Specifications

| Item | Performance | | | | | | | | |
|---|--|---|------|------|------|------|------|---------------|---------|
| Category temperature range (°C) | -55 to +105 | | | | | | | | |
| Tolerance at rated capacitance (%) | ±20 (20°C, 120Hz) | | | | | | | | |
| Leakage current (μA) | Less than 0.01CV or 3 whichever is larger (after 2 minutes) C : Rated capacitance (μF); V : Rated voltage (V) (20°C) | | | | | | | | |
| Tangent of loss angle (tanδ) | Rated voltage (V) | 6.3 | 10 | 16 | 25 | 35 | 50 | | |
| | tanδ (max.) | 0.22 | 0.19 | 0.16 | 0.14 | 0.12 | 0.10 | (20°C, 120Hz) | |
| Characteristics at high and low temperature | Impedance ratio (max.) | Rated voltage (V) | 6.3 | 10 | 16 | 25 | 35 | 50 | |
| | | Z-25°C/Z+20°C | 3 | 3 | 2 | 2 | 2 | 2 | (120Hz) |
| | | Z-40°C/Z+20°C | 8 | 5 | 4 | 3 | 3 | 3 | |
| Endurance (105°C) (Applied ripple current) | Test time | 1000 hours | | | | | | | |
| | Leakage current | The initial specified value or less | | | | | | | |
| | Percentage of capacitance change | Within ±20% of initial value | | | | | | | |
| | Tangent of the loss angle | 200% or less of the initial specified value | | | | | | | |
| Shelf life (105°C) | Test time : 1000 hours ; other items are the same as those for the endurance. Voltage application treatment : According to JIS C5101-1 | | | | | | | | |
| Applicable standards | JIS C5101-1, -4 1998 (IEC 60384-1 1992, -4 1985) | | | | | | | | |

Outline Drawing

Unit : mm

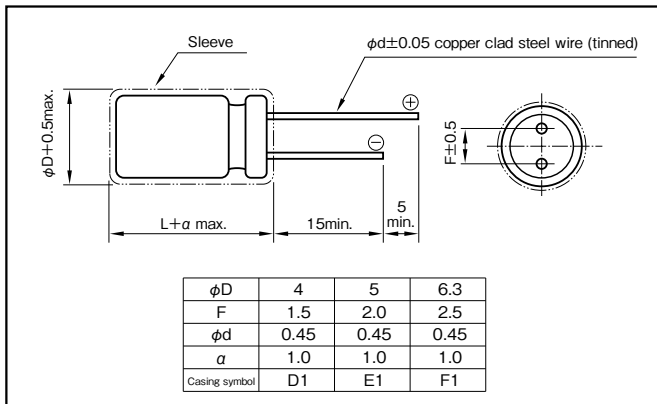

Coefficient of Frequency for Rated Ripple Current

| Rated voltage (V) | Frequency (Hz) | | | |
|-------------------|----------------|------|------|------------|
| | 50 · 60 | 120 | 1k | 10k · 100k |
| 6.3 to 16 | 0.68 | 0.72 | 0.92 | 1 |
| 25 to 35 | 0.48 | 0.63 | 0.80 | 1 |
| 50 | 0.45 | 0.50 | 0.70 | 1 |

Part numbering system (example : 25V33μF)

| | | | | | | | | | |
|-------------|---|----------------------|---|--------------------------|------------------------------|---------------|---|---|------------------------|
| R2S | — | 25 | V | 330 | M | F1 | # | — | |
| Series code | | Rated voltage symbol | | Rated capacitance symbol | Capacitance tolerance symbol | Casing symbol | | | Taping(Forming) symbol |

Standard Ratings

| Rated voltage (V) | 6.3 | | 10 | | 16 | | 25 | | 35 | | 50 | |
|-------------------|-------|---------------------------|-------|---------------------------|-------|---------------------------|-------|---------------------------|-------|---------------------------|-------|---------------------------|
| | Case | Rated ripple current (mA) | Case | Rated ripple current (mA) | Case | Rated ripple current (mA) | Case | Rated ripple current (mA) | Case | Rated ripple current (mA) | Case | Rated ripple current (mA) |
| 0.33 | — | — | — | — | — | — | — | — | — | — | 4×7 | 10 |
| 0.47 | — | — | — | — | — | — | — | — | — | — | 4×7 | 12 |
| 1 | — | — | — | — | — | — | — | — | — | — | 4×7 | 16 |
| 2.2 | — | — | — | — | — | — | — | — | — | — | 4×7 | 25 |
| 3.3 | — | — | — | — | — | — | 4×7 | 21 | 4×7 | 23 | 4×7 | 28 |
| 4.7 | — | — | — | — | — | — | 4×7 | 25 | 4×7 | 25 | 5×7 | 48 |
| 10 | — | — | — | — | 4×7 | 39 | 5×7 | 47 | 5×7 | 48 | 6.3×7 | 75 |
| 22 | 4×7 | 42 | 4×7 | 49 | 5×7 | 54 | 6.3×7 | 87 | 6.3×7 | 90 | — | — |
| 33 | 5×7 | 53 | 5×7 | 60 | 6.3×7 | 83 | 6.3×7 | 90 | — | — | — | — |
| 47 | 5×7 | 64 | 6.3×7 | 95 | 6.3×7 | 95 | — | — | — | — | — | — |
| 100 | 6.3×7 | 96 | — | — | — | — | — | — | — | — | — | — |

(Note) Rated ripple current : 105°C, 100kHz.

7mm L, Bipolar Capacitors

GREEN CAP Anti-cleaning solvent

• Diameters from $\phi 4$ to $\phi 6.3$ mm and a height of 7mm.

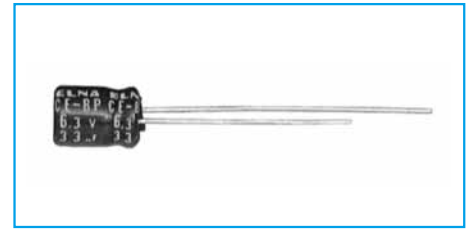
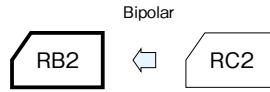

Marking color : White print on a blue sleeve

Specifications

| Item | Performance | | | | | | |
|------------------------------------|--|---|------|------|------|------|------|
| Category temperature range (°C) | -40 to +85 | | | | | | |
| Tolerance at rated capacitance (%) | ±20 (20°C, 120Hz) | | | | | | |
| Leakage current (µA) | Less than 0.03CV + 3 (after 5 minutes) C : Rated capacitance (µF) ; V : Rated voltage (V) (20°C) | | | | | | |
| Tangent of loss angle (tanδ) | Rated voltage (V) | 6.3 | 10 | 16 | 25 | 35 | 50 |
| | tanδ (max.) | 0.30 | 0.25 | 0.20 | 0.15 | 0.15 | 0.15 |
| Endurance (85°C) | Test time | 1000 hours (with the polarity inverted every 250 hours) | | | | | |
| | Leakage current | The initial specified value or less | | | | | |
| | Percentage of capacitance change | Within ±20% of initial value | | | | | |
| | Tangent of the loss angle | 200% or less of the initial specified value | | | | | |
| Applicable standards | JIS C5101-1, -4 1998 (IEC 60384-1 1992, -4 1985) | | | | | | |

Outline Drawing

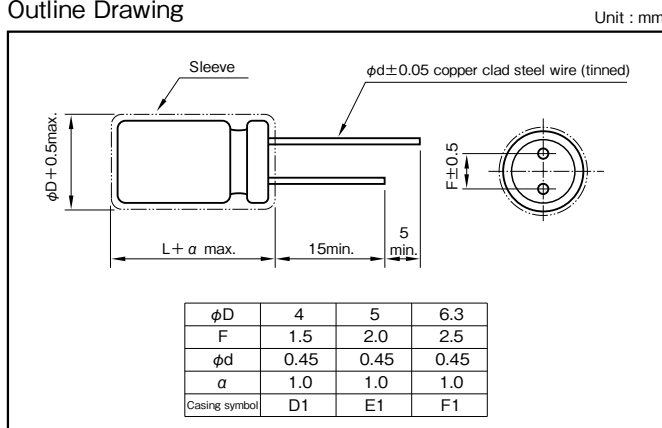

Coefficient of Frequency for Rated Ripple Current

| Rated voltage (V) | Frequency (Hz) | | | |
|-------------------|----------------|-----|-----|------------|
| | 50 · 60 | 120 | 1k | 10k · 100k |
| 6.3 to 16 | 0.8 | 1 | 1.1 | 1.2 |
| 25 to 35 | 0.8 | 1 | 1.5 | 1.7 |
| 50 | 0.8 | 1 | 1.6 | 1.9 |

Part numbering system (example: 16V47µF)

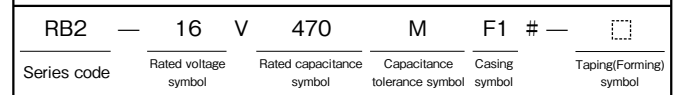

Standard Ratings

| Rated voltage (V) | 6.3 | | 10 | | 16 | | 25 | | 35 | | 50 | |
|-------------------|-------|------------------------------|-------|------------------------------|-------|------------------------------|-------|------------------------------|-------|------------------------------|-------|------------------------------|
| | Case | Rated ripple current (mArms) | Case | Rated ripple current (mArms) | Case | Rated ripple current (mArms) | Case | Rated ripple current (mArms) | Case | Rated ripple current (mArms) | Case | Rated ripple current (mArms) |
| 0.33 | — | — | — | — | — | — | — | — | — | — | 4×7 | 5 |
| 0.47 | — | — | — | — | — | — | — | — | — | — | 4×7 | 6 |
| 1 | — | — | — | — | — | — | — | — | — | — | 4×7 | 9 |
| 2.2 | — | — | — | — | — | — | — | — | 4×7 | 14 | 5×7 | 16 |
| 3.3 | — | — | — | — | — | — | 4×7 | 17 | 5×7 | 19 | 5×7 | 19 |
| 4.7 | — | — | — | — | 4×7 | 17 | 5×7 | 23 | 5×7 | 23 | 6.3×7 | 27 |
| 10 | — | — | 4×7 | 23 | 5×7 | 29 | 6.3×7 | 39 | 6.3×7 | 39 | — | — |
| 22 | 5×7 | 35 | 5×7 | 39 | 6.3×7 | 50 | 6.3×7 | 58 | — | — | — | — |
| 33 | 5×7 | 43 | 6.3×7 | 55 | 6.3×7 | 61 | 6.3×7 | 71 | — | — | — | — |
| 47 | 6.3×7 | 60 | 6.3×7 | 66 | 6.3×7 | 73 | — | — | — | — | — | — |

(Note) Rated ripple current : 85°C, 120Hz.

Standard Capacitors

GREEN CAP

Anti-cleaning solvent 250V Max.

• Guarantees 2000 hours at 85°C.



High temperature

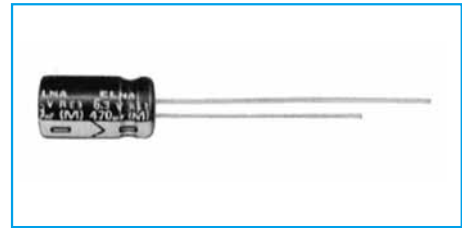

Marking color : White print on a blue sleeve

Specifications

| Item | Performance | | | | | | | | | | | | | | | | | | | | | | | | | | | | | | | | | | | | | | | | | | | | | | | |
|---|--|--|------------|------------|----------------------|---|--|------|------|------|------|------|------|------|------|-----|-----|------------------------|---------------|------|------|------|------|------|------|------|------|------|------|------|------|------|------|---------------|----|----|---|---|---|---|---|---|----|----|----|----|----|----|
| Category temperature range (°C) | -40 to +85 | | | | | | | | | | | | | | | | | | | | | | | | | | | | | | | | | | | | | | | | | | | | | | | |
| Tolerance at rated capacitance (%) | ±20 (20°C, 120Hz) | | | | | | | | | | | | | | | | | | | | | | | | | | | | | | | | | | | | | | | | | | | | | | | |
| Leakage current (µA) | <table border="1"> <tr> <td>Rated voltage (V)</td> <td>6.3 to 100</td> <td>160 to 450</td> </tr> <tr> <td>Leakage current (µA)</td> <td>Less than 0.03CV or 4 whichever is larger (after 1 minute) Less than 0.01CV or 3 whichever is larger (after 2 minutes)</td> <td>CV ≤ 1000 : Less than 0.1CV + 40 (after 1 minute) CV > 1000 : Less than 0.04CV + 100 (after 1 minute)</td> </tr> </table> | Rated voltage (V) | 6.3 to 100 | 160 to 450 | Leakage current (µA) | Less than 0.03CV or 4 whichever is larger (after 1 minute) Less than 0.01CV or 3 whichever is larger (after 2 minutes) | CV ≤ 1000 : Less than 0.1CV + 40 (after 1 minute) CV > 1000 : Less than 0.04CV + 100 (after 1 minute) | | | | | | | | | | | | | | | | | | | | | | | | | | | | | | | | | | | | | | | | | |
| | Rated voltage (V) | 6.3 to 100 | 160 to 450 | | | | | | | | | | | | | | | | | | | | | | | | | | | | | | | | | | | | | | | | | | | | | |
| Leakage current (µA) | Less than 0.03CV or 4 whichever is larger (after 1 minute) Less than 0.01CV or 3 whichever is larger (after 2 minutes) | CV ≤ 1000 : Less than 0.1CV + 40 (after 1 minute) CV > 1000 : Less than 0.04CV + 100 (after 1 minute) | | | | | | | | | | | | | | | | | | | | | | | | | | | | | | | | | | | | | | | | | | | | | | |
| C : Rated capacitance (µF) V : Rated voltage (V) (20°C) | | | | | | | | | | | | | | | | | | | | | | | | | | | | | | | | | | | | | | | | | | | | | | | | |
| Tangent of loss angle (tanδ) | <table border="1"> <tr> <td>Rated voltage (V)</td> <td>6.3</td><td>10</td><td>16</td><td>25</td><td>35</td><td>50</td><td>63</td><td>100</td><td>160</td><td>200</td><td>250</td><td>315</td><td>350</td><td>400</td><td>450</td> </tr> <tr> <td>tanδ (max.)</td> <td>0.28</td><td>0.24</td><td>0.20</td><td>0.16</td><td>0.14</td><td>0.12</td><td>0.10</td><td>0.08</td><td>0.20</td><td>0.20</td><td>0.20</td><td>0.24</td><td>0.24</td><td>0.24</td><td>0.24</td> </tr> </table> | Rated voltage (V) | 6.3 | 10 | 16 | 25 | 35 | 50 | 63 | 100 | 160 | 200 | 250 | 315 | 350 | 400 | 450 | tanδ (max.) | 0.28 | 0.24 | 0.20 | 0.16 | 0.14 | 0.12 | 0.10 | 0.08 | 0.20 | 0.20 | 0.20 | 0.24 | 0.24 | 0.24 | 0.24 | | | | | | | | | | | | | | | |
| | Rated voltage (V) | 6.3 | 10 | 16 | 25 | 35 | 50 | 63 | 100 | 160 | 200 | 250 | 315 | 350 | 400 | 450 | | | | | | | | | | | | | | | | | | | | | | | | | | | | | | | | |
| tanδ (max.) | 0.28 | 0.24 | 0.20 | 0.16 | 0.14 | 0.12 | 0.10 | 0.08 | 0.20 | 0.20 | 0.20 | 0.24 | 0.24 | 0.24 | 0.24 | | | | | | | | | | | | | | | | | | | | | | | | | | | | | | | | | |
| 0.02 is added to every 1000µF increase over 1000µF. (20°C, 120Hz) | | | | | | | | | | | | | | | | | | | | | | | | | | | | | | | | | | | | | | | | | | | | | | | | |
| Characteristics at high and low temperature | <table border="1"> <tr> <td>Rated voltage (V)</td> <td>6.3</td><td>10</td><td>16</td><td>25</td><td>35</td><td>50</td><td>63</td><td>100</td><td>160</td><td>200</td><td>250</td><td>315</td><td>350</td><td>400</td><td>450</td> </tr> <tr> <td rowspan="2">Impedance ratio (max.)</td> <td>Z-25°C/Z+20°C</td> <td>5</td><td>4</td><td>3</td><td>2</td><td>2</td><td>2</td><td>2</td><td>4</td><td>4</td><td>4</td><td>4</td><td>4</td><td>4</td><td>4</td> </tr> <tr> <td>Z-40°C/Z+20°C</td> <td>12</td><td>10</td><td>8</td><td>5</td><td>4</td><td>3</td><td>3</td><td>3</td><td>15</td><td>15</td><td>15</td><td>10</td><td>10</td><td>10</td> </tr> </table> | Rated voltage (V) | 6.3 | 10 | 16 | 25 | 35 | 50 | 63 | 100 | 160 | 200 | 250 | 315 | 350 | 400 | 450 | Impedance ratio (max.) | Z-25°C/Z+20°C | 5 | 4 | 3 | 2 | 2 | 2 | 2 | 4 | 4 | 4 | 4 | 4 | 4 | 4 | Z-40°C/Z+20°C | 12 | 10 | 8 | 5 | 4 | 3 | 3 | 3 | 15 | 15 | 15 | 10 | 10 | 10 |
| | Rated voltage (V) | 6.3 | 10 | 16 | 25 | 35 | 50 | 63 | 100 | 160 | 200 | 250 | 315 | 350 | 400 | 450 | | | | | | | | | | | | | | | | | | | | | | | | | | | | | | | | |
| Impedance ratio (max.) | Z-25°C/Z+20°C | 5 | 4 | 3 | 2 | 2 | 2 | 2 | 4 | 4 | 4 | 4 | 4 | 4 | 4 | | | | | | | | | | | | | | | | | | | | | | | | | | | | | | | | | |
| | Z-40°C/Z+20°C | 12 | 10 | 8 | 5 | 4 | 3 | 3 | 3 | 15 | 15 | 15 | 10 | 10 | 10 | | | | | | | | | | | | | | | | | | | | | | | | | | | | | | | | | |
| (120Hz) | | | | | | | | | | | | | | | | | | | | | | | | | | | | | | | | | | | | | | | | | | | | | | | | |
| Endurance (85°C) (Applied ripple current) | Test time | 2000 hours | | | | | | | | | | | | | | | | | | | | | | | | | | | | | | | | | | | | | | | | | | | | | | |
| | Leakage current | The initial specified value or less | | | | | | | | | | | | | | | | | | | | | | | | | | | | | | | | | | | | | | | | | | | | | | |
| | Percentage of capacitance change | Within ±20% of initial value | | | | | | | | | | | | | | | | | | | | | | | | | | | | | | | | | | | | | | | | | | | | | | |
| | Tangent of the loss angle | 200% or less of the initial specified value | | | | | | | | | | | | | | | | | | | | | | | | | | | | | | | | | | | | | | | | | | | | | | |
| Shelf life (85°C) | Test time : 1000 hours ; other items are the same as those for the endurance. Voltage application treatment : According to JIS C5101 -1 | | | | | | | | | | | | | | | | | | | | | | | | | | | | | | | | | | | | | | | | | | | | | | | |
| Applicable standards | JIS C5101-1, -4 1998 (IEC 60384-1 1992, -4 1985) | | | | | | | | | | | | | | | | | | | | | | | | | | | | | | | | | | | | | | | | | | | | | | | |

Outline Drawing

Unit : mm

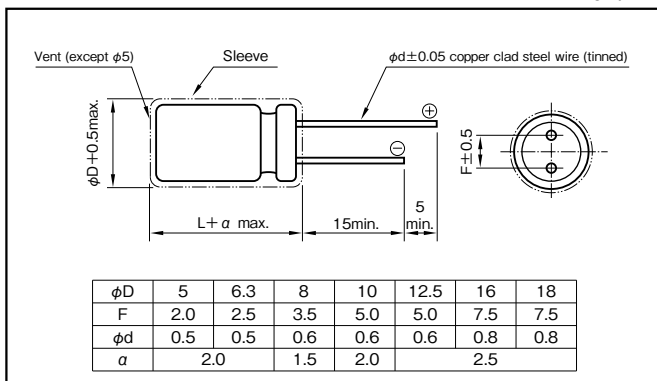

Coefficient of Frequency for Rated Ripple Current

| Rated voltage (V) | Frequency (Hz) CV (µF×VV) | 50 · 60 | 120 | 1k | 10k | 100k |
|-------------------|------------------------------|-----------|--------------|-----|-----|------|
| | | 6.3 to 16 | All CV value | 0.8 | 1 | 1.1 |
| 25 to 35 | ≤ 1000 | 0.8 | 1 | 1.5 | 1.7 | 1.7 |
| | 1000 < | 0.8 | 1 | 1.2 | 1.3 | 1.3 |
| 50 to 100 | ≤ 1000 | 0.8 | 1 | 1.6 | 1.9 | 1.9 |
| | 1000 < | 0.8 | 1 | 1.2 | 1.3 | 1.3 |
| 160 to 450 | All CV value | 0.8 | 1 | 1.3 | 1.5 | 1.6 |

Part numbering system (example : 16V1000µF)

| | | | | | | | | | | |
|-------------|---|----------------------|---|--------------------------|------------------------------|---------------|-----------------|---|---|-----------------------|
| RE3 | — | 16 | V | 102 | M | H4 | # | □ | — | □ |
| Series code | | Rated voltage symbol | | Rated capacitance symbol | Capacitance tolerance symbol | Casing symbol | Optional symbol | | | Taping/Forming symbol |

Casing symbol

| Size φD×L (mm) | Casing Symbol | Size φD×L (mm) | Casing Symbol |
|-------------------|---------------|-------------------|---------------|
| 5×11 | E3 | 12.5×25 | I6 |
| 6.3×11 | F3 | 16×25 | J6 |
| 8×11.5 | G3 | 16×31.5 | J7 |
| 10×12.5 | H3 | 16×35.5 | J8 |
| 10×16 | H4 | 18×31.5 | K7 |
| 10×20 | H5 | 18×35.5 | K8 |
| 12.5×20 | I5 | 18×40 | K9 |

Standard Ratings

| Rated voltage (V) Rated capacitance (μF) Item | 6.3 | | | 10 | | | 16 | | | 25 | | | 35 | | | 50 | | | 63 | | | 100 | | |
|---|-----------|---------|-------------------------------|-----------|---------|-------------------------------|-----------|---------|-------------------------------|-----------|---------|-------------------------------|-----------|---------|-------------------------------|-----------|---------|-------------------------------|-----------|---------|-------------------------------|-----------|---------|-------------------------------|
| | Case | ESR (Ω) | Rated ripple current (mA rms) | Case | ESR (Ω) | Rated ripple current (mA rms) | Case | ESR (Ω) | Rated ripple current (mA rms) | Case | ESR (Ω) | Rated ripple current (mA rms) | Case | ESR (Ω) | Rated ripple current (mA rms) | Case | ESR (Ω) | Rated ripple current (mA rms) | Case | ESR (Ω) | Rated ripple current (mA rms) | Case | ESR (Ω) | Rated ripple current (mA rms) |
| | φD×L (mm) | | | φD×L (mm) | | | φD×L (mm) | | | φD×L (mm) | | | φD×L (mm) | | | φD×L (mm) | | | φD×L (mm) | | | φD×L (mm) | | |
| 1 | — | — | — | — | — | — | — | — | — | — | — | — | — | — | — | 5×11 | 199 | 21 | — | — | — | 5×11 | 133 | 21 |
| 2.2 | — | — | — | — | — | — | — | — | — | — | — | — | — | — | — | 5×11 | 90.5 | 31 | — | — | — | 5×11 | 60.3 | 30 |
| 3.3 | — | — | — | — | — | — | — | — | — | — | — | — | — | — | — | 5×11 | 60.3 | 38 | — | — | — | 5×11 | 40.2 | 40 |
| 4.7 | — | — | — | — | — | — | — | — | — | 5×11 | 56.5 | 38 | 5×11 | 49.4 | 40 | 5×11 | 42.3 | 45 | 5×11 | 35.3 | 45 | 5×11 | 28.2 | 45 |
| 10 | — | — | — | — | — | — | 5×11 | 33.2 | 50 | 5×11 | 26.5 | 55 | 5×11 | 23.2 | 59 | 5×11 | 19.9 | 66 | 5×11 | 16.6 | 66 | 6.3×11 | 13.3 | 75 |
| 22 | — | — | — | — | — | — | 5×11 | 15.1 | 75 | 5×11 | 12.1 | 82 | 5×11 | 10.6 | 87 | 5×11 | 9.1 | 98 | 5×11 | 7.5 | 100 | 6.3×11 | 6.0 | 130 |
| 33 | — | — | — | — | — | — | 5×11 | 10.1 | 92 | 5×11 | 8.0 | 100 | 5×11 | 7.0 | 107 | 5×11 | 6.0 | 126 | 6.3×11 | 5.0 | 140 | 8×11.5 | 4.0 | 180 |
| 47 | — | — | — | 5×11 | 8.5 | 99 | 5×11 | 7.1 | 110 | 5×11 | 5.7 | 118 | 5×11 | 4.9 | 130 | 6.3×11 | 4.2 | 155 | 6.3×11 | 3.5 | 170 | 10×12.5 | 2.8 | 230 |
| 100 | — | — | — | 5×11 | 3.8 | 146 | 5×11 | 3.3 | 160 | 6.3×11 | 2.7 | 199 | 6.3×11 | 2.3 | 214 | 8×11.5 | 2.0 | 260 | 10×12.5 | 1.7 | 300 | 10×20 | 1.3 | 370 |
| 220 | 5×11 | 2.1 | 200 | 6.3×11 | 1.8 | 240 | 6.3×11 | 1.5 | 264 | 8×11.5 | 1.2 | 349 | 10×12.5 | 1.1 | 443 | 10×12.5 | 0.91 | 443 | 10×16 | 0.75 | 470 | 12.5×20 | 0.60 | 620 |
| 330 | 6.3×11 | 1.4 | 270 | 6.3×11 | 1.2 | 290 | 8×11.5 | 1.0 | 383 | 10×12.5 | 0.81 | 510 | 10×12.5 | 0.70 | 542 | 10×16 | 0.60 | 595 | 10×20 | 0.50 | 710 | 12.5×25 | 0.40 | 760 |
| 470 | 6.3×11 | 0.99 | 322 | 8×11.5 | 0.85 | 417 | 8×11.5 | 0.71 | 457 | 10×12.5 | 0.57 | 545 | 10×16 | 0.49 | 664 | 12.5×20 | 0.42 | 887 | 12.5×20 | 0.35 | 900 | 16×25 | 0.28 | 1000 |
| 1000 | 8×11.5 | 0.47 | 546 | 10×12.5 | 0.40 | 650 | 10×16 | 0.33 | 791 | 10×20 | 0.27 | 996 | 12.5×20 | 0.23 | 1210 | 12.5×25 | 0.20 | 1400 | 16×25 | 0.17 | 1300 | 18×40 | 0.13 | 1380 |
| 2200 | 10×20 | 0.23 | 1010 | 10×20 | 0.20 | 1080 | 12.5×20 | 0.17 | 1350 | 12.5×25 | 0.14 | 1660 | 16×25 | 0.12 | 1950 | 16×35.5 | 0.11 | 2340 | — | — | — | — | — | — |
| 3300 | 10×20 | 0.16 | 1230 | 12.5×20 | 0.14 | 1430 | 12.5×25 | 0.12 | 1690 | 16×25 | 0.10 | 2030 | 16×35.5 | 0.090 | 2510 | 18×35.5 | 0.080 | 2810 | — | — | — | — | — | — |
| 4700 | 12.5×20 | 0.12 | 1710 | 12.5×25 | 0.11 | 1780 | 16×25 | 0.092 | 2100 | 16×31.5 | 0.078 | 2650 | 18×35.5 | 0.071 | 2990 | — | — | — | — | — | — | — | — | — |
| 6800 | 12.5×25 | 0.093 | 1930 | 16×25 | 0.083 | 2200 | 16×35.5 | 0.073 | 2580 | 18×35.5 | 0.063 | 3290 | — | — | — | — | — | — | — | — | — | — | — | — |
| 10000 | 16×25 | 0.076 | 2450 | 16×35.5 | 0.070 | 2700 | 18×35.5 | 0.063 | 3130 | — | — | — | — | — | — | — | — | — | — | — | — | — | — | — |
| 15000 | 16×35.5 | 0.062 | 2860 | 18×35.5 | 0.058 | 3100 | — | — | — | — | — | — | — | — | — | — | — | — | — | — | — | — | — | — |
| 22000 | 18×40 | 0.053 | 3340 | — | — | — | — | — | — | — | — | — | — | — | — | — | — | — | — | — | — | — | — | — |

| Rated voltage (V) Rated capacitance (μF) Item | 160 | | | 200 | | | 250 | | | 315 | | | 350 | | | 400 | | | 450 | | | | | |
|---|-----------|---------|-------------------------------|-----------|---------|-------------------------------|-----------|---------|-------------------------------|-----------|---------|-------------------------------|-----------|---------|-------------------------------|-----------|---------|-------------------------------|-----------|---------|-------------------------------|---|---|---|
| | Case | ESR (Ω) | Rated ripple current (mA rms) | Case | ESR (Ω) | Rated ripple current (mA rms) | Case | ESR (Ω) | Rated ripple current (mA rms) | Case | ESR (Ω) | Rated ripple current (mA rms) | Case | ESR (Ω) | Rated ripple current (mA rms) | Case | ESR (Ω) | Rated ripple current (mA rms) | Case | ESR (Ω) | Rated ripple current (mA rms) | | | |
| | φD×L (mm) | | | φD×L (mm) | | | φD×L (mm) | | | φD×L (mm) | | | φD×L (mm) | | | φD×L (mm) | | | φD×L (mm) | | | | | |
| 0.47 | 6.3×11 | 706 | 15 | 6.3×11 | 706 | 15 | 6.3×11 | 706 | 15 | 6.3×11 | 847 | 15 | 6.3×11 | 847 | 15 | 6.3×11 | 847 | 15 | 8×11.5 | 847 | 18 | | | |
| 1 | 6.3×11 | 332 | 22 | 6.3×11 | 332 | 22 | 6.3×11 | 332 | 22 | 6.3×11 | 398 | 22 | 6.3×11 | 398 | 22 | 6.3×11 | 398 | 22 | 8×11.5 | 398 | 25 | | | |
| 2.2 | 6.3×11 | 151 | 32 | 6.3×11 | 151 | 32 | 6.3×11 | 151 | 32 | 8×11.5 | 181 | 38 | 8×11.5 | 181 | 38 | 8×11.5 | 181 | 38 | 10×12.5 | 181 | 43 | | | |
| 3.3 | 6.3×11 | 101 | 40 | 6.3×11 | 101 | 40 | 8×11.5 | 101 | 48 | 10×12.5 | 121 | 53 | 10×12.5 | 121 | 53 | 10×12.5 | 121 | 54 | 10×16 | 121 | 59 | | | |
| 4.7 | 6.3×11 | 70.6 | 48 | 8×11.5 | 70.6 | 56 | 8×11.5 | 70.6 | 56 | 10×12.5 | 84.7 | 65 | 10×12.5 | 84.7 | 65 | 10×16 | 84.7 | 71 | 10×20 | 84.7 | 76 | | | |
| 10 | 8×11.5 | 33.2 | 81 | 10×12.5 | 33.2 | 94 | 10×16 | 33.2 | 101 | 10×20 | 39.8 | 115 | 10×20 | 39.8 | 115 | 12.5×20 | 39.8 | 123 | 12.5×20 | 39.8 | 123 | | | |
| 22 | 10×16 | 15.1 | 151 | 10×20 | 15.1 | 170 | 12.5×20 | 15.1 | 182 | 12.5×20 | 18.1 | 182 | 12.5×25 | 18.1 | 197 | 12.5×25 | 18.1 | 197 | 16×25 | 18.1 | 226 | | | |
| 33 | 10×20 | 10.1 | 202 | 12.5×20 | 10.1 | 223 | 12.5×25 | 10.1 | 243 | 16×25 | 12.1 | 277 | 16×25 | 12.1 | 277 | 16×25 | 12.1 | 277 | 16×31.5 | 12.1 | 304 | | | |
| 47 | 12.5×20 | 7.06 | 266 | 12.5×25 | 7.06 | 265 | 12.5×25 | 7.06 | 295 | 16×25 | 8.47 | 330 | 16×25 | 8.47 | 330 | 16×31.5 | 8.47 | 361 | 16×35.5 | 8.47 | 380 | | | |
| 100 | 12.5×25 | 3.32 | 422 | 16×25 | 3.32 | 483 | 16×31.5 | 3.32 | 528 | 18×31.5 | 3.98 | 567 | 18×31.5 | 3.98 | 567 | — | — | — | — | — | — | — | — | |
| 220 | 16×31.5 | 1.51 | 783 | 18×35.5 | 1.51 | 882 | — | — | — | — | — | — | — | — | — | — | — | — | — | — | — | — | — | |
| 330 | 18×35.5 | 1.01 | 1080 | — | — | — | — | — | — | — | — | — | — | — | — | — | — | — | — | — | — | — | — | — |

(Note) Rated ripple current : 85°C, 120Hz ; ESR : 20°C, 120Hz

Standard Bipolar Capacitors

GREEN CAP Anti-cleaning solvent

• Guarantees 2000 hours at 85°C.



Marking color : White print on a blue sleeve

Specifications

| Item | Performance | | | | | | | | | |
|---|--|---------------|---|------|------|------|------|------|------|------|
| Category temperature range (°C) | -40 to +85 | | | | | | | | | |
| Tolerance at rated capacitance (%) | ±20 (20°C, 120Hz) | | | | | | | | | |
| Leakage current (µA) | Less than 0.03CV + 3 (after 5 minutes) C : Rated capacitance (µF) ; V : Rated voltage (V) (20°C) | | | | | | | | | |
| Tangent of loss angle (tanδ) | Rated voltage (V) | | 6.3 | 10 | 16 | 25 | 35 | 50 | 63 | 100 |
| | tan δ (max.) | | 0.24 | 0.24 | 0.20 | 0.20 | 0.16 | 0.14 | 0.12 | 0.10 |
| 0.02 is added to every 1000µF increase over 1000µF (20°C, 120Hz) | | | | | | | | | | |
| Characteristics at high and low temperature | Rated voltage (V) | | 6.3 | 10 | 16 | 25 | 35 | 50 | 63 | 100 |
| | Impedance ratio (max.) | Z-25°C/Z+20°C | 4 | 3 | 2 | 2 | 2 | 2 | 2 | 2 |
| | | Z-40°C/Z+20°C | 10 | 8 | 6 | 4 | 3 | 3 | 3 | 3 |
| 0.5 for -25°C, 1 for -40°C are added to every 1000µF increase over 1000µF (120Hz) | | | | | | | | | | |
| Endurance (85°C) (Applied ripple current) | Test time | | 2000 hours (with the polarity inverted every 250 hours) | | | | | | | |
| | Leakage current | | The initial specified value or less | | | | | | | |
| | Percentage of capacitance change | | Within ±20% of initial value | | | | | | | |
| | Tangent of the loss angle | | 150% or less of the initial specified value | | | | | | | |
| Shelf life (85°C) | Test time : 1000 hours. Other have same as endurance. Voltage application treatment | | | | | | | | | |
| Applicable standards | JIS C5101-1, -4 1998 (IEC 60384-1 1992, -4 1985) | | | | | | | | | |

Outline Drawing

Unit : mm

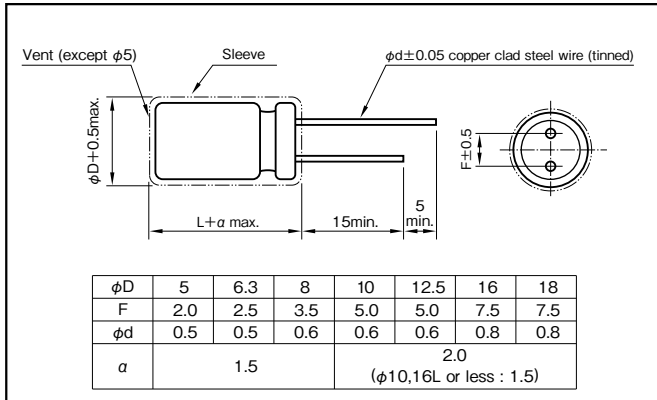

Coefficient of Frequency for Rated Ripple Current

| Rated voltage (V) \ Frequency (Hz) | 50 · 60 | 120 | 1k | 10k · 100k |
|------------------------------------|---------|-----|-----|------------|
| 6.3 to 16 | 0.8 | 1 | 1.1 | 1.2 |
| 25 to 35 | 0.8 | 1 | 1.5 | 1.7 |
| 50 to 100 | 0.8 | 1 | 1.6 | 1.9 |

Part numbering system (example : 10V1000µF)

| | | | | | | | | | |
|-------------|---|----------------------|---|--------------------------|------------------------------|---------------|---|---|------------------------|
| R2B | — | 10 | V | 102 | M | I5 | # | — | □ |
| Series code | | Rated voltage symbol | | Rated capacitance symbol | Capacitance tolerance symbol | Casing symbol | | | Taping(Forming) symbol |

Casing symbol

| Case φD×L (mm) | Casing Symbol | Case φD×L (mm) | Casing Symbol | Case φD×L (mm) | Casing Symbol | Case φD×L (mm) | Casing Symbol |
|----------------|---------------|----------------|---------------|----------------|---------------|----------------|---------------|
| 5×11 | E3 | 10×12.5 | H3 | 12.5×20 | I5 | 16×31.5 | J7 |
| 6.3×11 | F3 | 10×16 | H4 | 12.5×25 | I6 | 16×35.5 | J8 |
| 8×11.5 | G3 | 10×20 | H5 | 16×25 | J6 | 18×35.5 | K8 |

Standard Ratings

| Rated capacitance (µF) | 6.3 | | 10 | | 16 | | 25 | | 35 | | 50 | | 63 | | 100 | |
|------------------------|----------------|-------------------------------|----------------|-------------------------------|----------------|-------------------------------|----------------|-------------------------------|----------------|-------------------------------|----------------|-------------------------------|----------------|-------------------------------|----------------|-------------------------------|
| | Case φD×L (mm) | Rated ripple current (mA rms) | Case φD×L (mm) | Rated ripple current (mA rms) | Case φD×L (mm) | Rated ripple current (mA rms) | Case φD×L (mm) | Rated ripple current (mA rms) | Case φD×L (mm) | Rated ripple current (mA rms) | Case φD×L (mm) | Rated ripple current (mA rms) | Case φD×L (mm) | Rated ripple current (mA rms) | Case φD×L (mm) | Rated ripple current (mA rms) |
| 1 | — | — | — | — | — | — | — | — | — | — | 5×11 | 14 | — | — | 5×11 | 16 |
| 2.2 | — | — | — | — | — | — | — | — | — | — | 5×11 | 21 | 5×11 | 23 | 5×11 | 24 |
| 3.3 | — | — | — | — | — | — | — | — | — | — | 5×11 | 26 | 5×11 | 28 | 6.3×11 | 34 |
| 4.7 | — | — | — | — | — | — | 5×11 | 28 | 5×11 | 28 | 5×11 | 31 | 5×11 | 34 | 6.3×11 | 41 |
| 10 | — | — | — | — | 5×11 | 39 | 5×11 | 40 | 5×11 | 42 | 5×11 | 45 | 6.3×11 | 57 | 8×11.5 | 70 |
| 22 | — | — | 5×11 | 52 | 5×11 | 58 | 5×11 | 60 | 6.3×11 | 71 | 6.3×11 | 77 | 8×11.5 | 89 | 10×16 | 136 |
| 33 | 5×11 | 58 | 5×11 | 63 | 5×11 | 71 | 6.3×11 | 84 | 6.3×11 | 87 | 8×11.5 | 111 | 10×12.5 | 144 | 10×20 | 181 |
| 47 | 5×11 | 69 | 5×11 | 75 | 6.3×11 | 97 | 6.3×11 | 100 | 8×11.5 | 122 | 10×12.5 | 157 | 10×16 | 188 | 12.5×20 | 248 |
| 100 | 6.3×11 | 115 | 6.3×11 | 126 | 8×11.5 | 167 | 10×12.5 | 204 | 10×12.5 | 212 | 10×20 | 273 | 12.5×20 | 343 | 16×25 | 458 |
| 220 | 8×11.5 | 202 | 8×11.5 | 221 | 10×12.5 | 294 | 10×16 | 332 | 10×20 | 375 | 12.5×25 | 506 | 16×25 | 645 | 18×35.5 | 837 |
| 330 | 8×11.5 | 247 | 10×12.5 | 322 | 10×16 | 394 | 10×20 | 444 | 12.5×20 | 526 | 12.5×25 | 620 | — | — | — | — |
| 470 | 10×12.5 | 350 | 10×16 | 420 | 10×20 | 513 | 12.5×20 | 607 | 12.5×25 | 685 | 16×25 | 861 | — | — | — | — |
| 1000 | 10×20 | 611 | 12.5×20 | 767 | 12.5×25 | 935 | 16×25 | 1120 | 16×31.5 | 1270 | — | — | — | — | — | — |
| 2200 | 12.5×25 | 1090 | 16×25 | 1380 | 16×31.5 | 1660 | — | — | — | — | — | — | — | — | — | — |
| 3300 | 16×25 | 1490 | 16×31.5 | 1760 | — | — | — | — | — | — | — | — | — | — | — | — |
| 4700 | 16×31.5 | 1880 | 18×35.5 | 2280 | — | — | — | — | — | — | — | — | — | — | — | — |

(Note) Rated ripple current : 85°C, 120Hz

105°C Bipolar Capacitors

GREEN CAP Anti-cleaning solvent

• Guarantees 2000 hours at 105°C.



High temperature

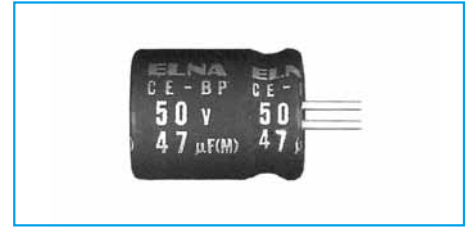

Marking color : White print on a black sleeve

Specifications

| Item | Performance | | | | | | |
|---|--|---|-----|-----|-----|------|------|
| Category temperature range (°C) | -40 to +105 | | | | | | |
| Tolerance at rated capacitance (%) | ±20 (20°C,120Hz) | | | | | | |
| Leakage current (µA) | Less than 0.03CV + 3 (after 5 minutes) C : Rated capacitance (µF) ; V : Rated voltage (V) (20°C) | | | | | | |
| Tangent of loss angle (tanδ) | Rated voltage (V) | 6.3 | 10 | 16 | 25 | 35 | 50 |
| | tan δ (max.) | 0.4 | 0.3 | 0.2 | 0.2 | 0.16 | 0.14 |
| 0.02 is added to every 1000µF increase over 1000µF (20°C,120Hz) | | | | | | | |
| Characteristics at high and low temperature | Rated voltage (V) | 6.3 | 10 | 16 | 25 | 35 | 50 |
| | Impedance ratio (max.) | Z-25°C/Z+20°C | 5 | 4 | 3 | 2 | 2 |
| 0.5 for -25°C, 1 for -40°C are added to every 1000µF increase over 1000µF (120Hz) | | | | | | | |
| Endurance (105°C) (Applied ripple current) | Test time | 2000 hours (φ5 to φ8 : 1000 hours) with the polarity inverted every 250 hours | | | | | |
| | Leakage current | The initial specified value or less | | | | | |
| | Percentage of capacitance change | Within ±20% of initial value | | | | | |
| | Tangent of the loss angle | 200% or less of the initial specified value | | | | | |
| Shelf life (105°C) | Test time : 1000 hours. Other have same as endurance. Voltage application treatment | | | | | | |
| Applicable standards | JIS C5101-1, -4 1998 (IEC 60384-1 1992, -4 1985) | | | | | | |

Outline Drawing

Unit : mm

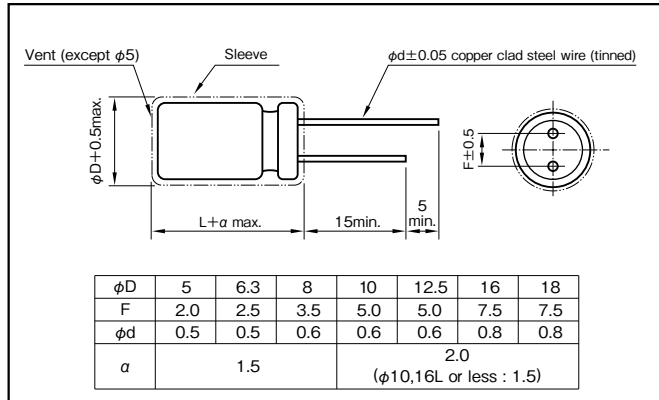

Coefficient of Frequency for Rated Ripple Current

| Rated voltage (V) \ Frequency (Hz) | 50 · 60 | 120 | 1k | 10k · 100k |
|------------------------------------|---------|-----|-----|------------|
| 6.3 to 16 | 0.8 | 1 | 1.1 | 1.2 |
| 25 to 35 | 0.8 | 1 | 1.5 | 1.7 |
| 50 | 0.8 | 1 | 1.6 | 1.9 |

Part numbering system (example : 10V1000µF)

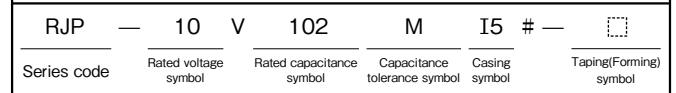

Casing symbol

| Case φD×L (mm) | Casing Symbol | Case φD×L (mm) | Casing Symbol | Case φD×L (mm) | Casing Symbol | Case φD×L (mm) | Casing Symbol |
|----------------|---------------|----------------|---------------|----------------|---------------|----------------|---------------|
| 5×11 | E3 | 10×12.5 | H3 | 12.5×20 | I5 | 16×31.5 | J7 |
| 6.3×11 | F3 | 10×16 | H4 | 12.5×25 | J6 | 18×35.5 | K8 |
| 8×11.5 | G3 | 10×20 | H5 | 16×25 | | | |

Standard Ratings

| Rated capacitance (µF) \ Rated voltage (V) | 6.3 | | 10 | | 16 | | 25 | | 35 | | 50 | |
|--|----------------|-------------------------------|----------------|-------------------------------|----------------|-------------------------------|----------------|-------------------------------|----------------|-------------------------------|----------------|-------------------------------|
| | Case φD×L (mm) | Rated ripple current (mA rms) | Case φD×L (mm) | Rated ripple current (mA rms) | Case φD×L (mm) | Rated ripple current (mA rms) | Case φD×L (mm) | Rated ripple current (mA rms) | Case φD×L (mm) | Rated ripple current (mA rms) | Case φD×L (mm) | Rated ripple current (mA rms) |
| 1 | — | — | — | — | — | — | — | — | — | — | 5×11 | 12 |
| 2.2 | — | — | — | — | — | — | — | — | — | — | 5×11 | 18 |
| 3.3 | — | — | — | — | — | — | — | — | — | — | 5×11 | 22 |
| 4.7 | — | — | — | — | — | — | — | — | 5×11 | 25 | 5×11 | 22 |
| 10 | — | — | — | — | 5×11 | 30 | 5×11 | 34 | 5×11 | 30 | 6.3×11 | 37 |
| 22 | — | — | 5×11 | 42 | 5×11 | 40 | 6.3×11 | 55 | 6.3×11 | 51 | 8×11.5 | 63 |
| 33 | 5×11 | 46 | 5×11 | 45 | 5×11 | 49 | 6.3×11 | 56 | 8×11.5 | 72 | 8×11.5 | 77 |
| 47 | 5×11 | 54 | 5×11 | 54 | 6.3×11 | 67 | 6.3×11 | 67 | 8×11.5 | 86 | 10×12.5 | 105 |
| 100 | 6.3×11 | 90 | 6.3×11 | 96 | 8×11.5 | 110 | 8×11.5 | 110 | 10×16 | 160 | 10×20 | 190 |
| 220 | 8×11.5 | 150 | 8×11.5 | 150 | 10×12.5 | 195 | 10×16 | 215 | 12.5×20 | 290 | 12.5×25 | 340 |
| 330 | 8×11.5 | 185 | 10×16 | 240 | 10×16 | 265 | 12.5×20 | 320 | 12.5×20 | 350 | 16×25 | 460 |
| 470 | 10×12.5 | 260 | 10×16 | 290 | 10×20 | 345 | 12.5×20 | 380 | 12.5×25 | 465 | 16×31.5 | 590 |
| 1000 | 10×20 | 460 | 12.5×20 | 510 | 12.5×25 | 605 | 16×25 | 670 | 16×31.5 | 805 | — | — |
| 2200 | 12.5×25 | 820 | 16×25 | 910 | 16×31.5 | 1070 | 18×35.5 | 1140 | — | — | — | — |
| 3300 | 16×25 | 1110 | 16×31.5 | 1200 | 18×35.5 | 1400 | — | — | — | — | — | — |
| 4700 | 16×31.5 | 1430 | 18×35.5 | 1520 | — | — | — | — | — | — | — | — |
| 6800 | 18×35.5 | 1830 | — | — | — | — | — | — | — | — | — | — |

(Note) Rated ripple current : 105°C , 120Hz

105°C Miniature Capacitors

GREEN CAP

105°C
1000hours

Anti-cleaning solvent
250V Max.

• Case size is one rank smaller than Series RJ4.

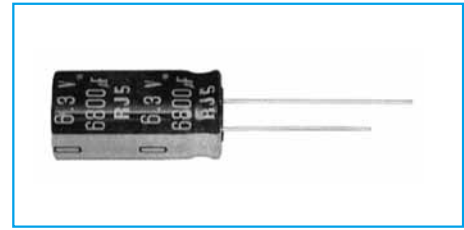
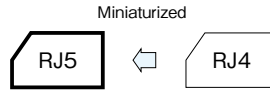

Marking color : White print on a black sleeve

Specifications

| Item | Performance | | | | | | | | | | | | | | | | | | | | | | | | | | | | | | | | | | | | | | | | | | | | | | | | | | | | | | | |
|---|---|--|--|------|------|------|------|------|------|------------|------|------------|------|------|------|-----|-------------------|-----|----|----|----|----|----|----|-----|------------|-----|------------|-----|------------------------|---------------|-----|--------------|------|------|------|------|------|------|------|------|------|------|---------------|------|------|------|------|---|---|---|---|----|--|----|--|
| Category temperature range (°C) | -55~+105 | -40~+105 | | | | | | | | | | | | | | | | | | | | | | | | | | | | | | | | | | | | | | | | | | | | | | | | | | | | | | |
| Rated voltage (V) | 6.3~100 | 160~450 | | | | | | | | | | | | | | | | | | | | | | | | | | | | | | | | | | | | | | | | | | | | | | | | | | | | | | |
| Tolerance at rated capacitance (%) | ±20 (20°C, 120Hz) | | | | | | | | | | | | | | | | | | | | | | | | | | | | | | | | | | | | | | | | | | | | | | | | | | | | | | | |
| Leakage current (µA) | Less than 0.03CV or 4 whichever is larger (after 1 minute) Less than 0.01CV or 3 whichever is larger (after 2 minutes) | CV ≤ 1000 : Less than 0.1CV+40 (after 1 minute) CV > 1000 : Less than 0.04CV+100 (after 1 minute) | | | | | | | | | | | | | | | | | | | | | | | | | | | | | | | | | | | | | | | | | | | | | | | | | | | | | | |
| | C : Rated capacitance (µF) ; V : Rated voltage (V) (20°C) | | | | | | | | | | | | | | | | | | | | | | | | | | | | | | | | | | | | | | | | | | | | | | | | | | | | | | | |
| Tangent of loss angle (tanδ) | <table border="1"> <thead> <tr> <th>Rated voltage (V)</th> <th>6.3</th><th>10</th><th>16</th><th>25</th><th>35</th><th>50</th><th>63</th><th>100</th><th>160</th><th>200</th><th>250</th><th>315</th><th>350</th><th>400</th><th>450</th> </tr> </thead> <tbody> <tr> <td>tan δ (max.)</td> <td>0.34</td><td>0.26</td><td>0.20</td><td>0.16</td><td>0.14</td><td>0.12</td><td>0.10</td><td>0.08</td><td>0.20</td><td>0.20</td><td>0.20</td><td>0.24</td><td>0.24</td><td>0.24</td><td>0.24</td> </tr> </tbody> </table> | | | | | | | | | | | | | | | | Rated voltage (V) | 6.3 | 10 | 16 | 25 | 35 | 50 | 63 | 100 | 160 | 200 | 250 | 315 | 350 | 400 | 450 | tan δ (max.) | 0.34 | 0.26 | 0.20 | 0.16 | 0.14 | 0.12 | 0.10 | 0.08 | 0.20 | 0.20 | 0.20 | 0.24 | 0.24 | 0.24 | 0.24 | | | | | | | | |
| | Rated voltage (V) | 6.3 | 10 | 16 | 25 | 35 | 50 | 63 | 100 | 160 | 200 | 250 | 315 | 350 | 400 | 450 | | | | | | | | | | | | | | | | | | | | | | | | | | | | | | | | | | | | | | | | |
| tan δ (max.) | 0.34 | 0.26 | 0.20 | 0.16 | 0.14 | 0.12 | 0.10 | 0.08 | 0.20 | 0.20 | 0.20 | 0.24 | 0.24 | 0.24 | 0.24 | | | | | | | | | | | | | | | | | | | | | | | | | | | | | | | | | | | | | | | | | |
| 0.02 is added to every 1000µF increase over 1000µF. (20°C, 120Hz) | | | | | | | | | | | | | | | | | | | | | | | | | | | | | | | | | | | | | | | | | | | | | | | | | | | | | | | | |
| Characteristics at high and low temperature | <table border="1"> <thead> <tr> <th>Rated voltage (V)</th> <th>6.3</th><th>10</th><th>16</th><th>25</th><th>35</th><th>50</th><th>63</th><th>100</th><th colspan="2">160 to 250</th><th colspan="2">315 to 450</th> </tr> </thead> <tbody> <tr> <td rowspan="2">Impedance ratio (max.)</td> <td>Z-25°C/Z+20°C</td> <td>5</td><td>4</td><td>3</td><td>2</td><td>2</td><td>2</td><td>2</td><td>2</td><td colspan="2">4</td><td colspan="2">4</td> </tr> <tr> <td>Z-40°C/Z+20°C</td> <td>10</td><td>8</td><td>6</td><td>4</td><td>3</td><td>3</td><td>3</td><td>3</td><td colspan="2">15</td><td colspan="2">10</td> </tr> </tbody> </table> | | | | | | | | | | | | | | | | Rated voltage (V) | 6.3 | 10 | 16 | 25 | 35 | 50 | 63 | 100 | 160 to 250 | | 315 to 450 | | Impedance ratio (max.) | Z-25°C/Z+20°C | 5 | 4 | 3 | 2 | 2 | 2 | 2 | 2 | 4 | | 4 | | Z-40°C/Z+20°C | 10 | 8 | 6 | 4 | 3 | 3 | 3 | 3 | 15 | | 10 | |
| | Rated voltage (V) | 6.3 | 10 | 16 | 25 | 35 | 50 | 63 | 100 | 160 to 250 | | 315 to 450 | | | | | | | | | | | | | | | | | | | | | | | | | | | | | | | | | | | | | | | | | | | | |
| Impedance ratio (max.) | Z-25°C/Z+20°C | 5 | 4 | 3 | 2 | 2 | 2 | 2 | 2 | 4 | | 4 | | | | | | | | | | | | | | | | | | | | | | | | | | | | | | | | | | | | | | | | | | | | |
| | Z-40°C/Z+20°C | 10 | 8 | 6 | 4 | 3 | 3 | 3 | 3 | 15 | | 10 | | | | | | | | | | | | | | | | | | | | | | | | | | | | | | | | | | | | | | | | | | | | |
| (120Hz) | | | | | | | | | | | | | | | | | | | | | | | | | | | | | | | | | | | | | | | | | | | | | | | | | | | | | | | | |
| Endurance (105°C) (Applied ripple current) | Test time | | 2000 hours (φ5 to φ8, 100V or less : 1000 hours) | | | | | | | | | | | | | | | | | | | | | | | | | | | | | | | | | | | | | | | | | | | | | | | | | | | | | |
| | Leakage current | | The initial specified value or less | | | | | | | | | | | | | | | | | | | | | | | | | | | | | | | | | | | | | | | | | | | | | | | | | | | | | |
| | Percentage of capacitance change | | Within ±20% of initial value | | | | | | | | | | | | | | | | | | | | | | | | | | | | | | | | | | | | | | | | | | | | | | | | | | | | | |
| | Tangent of the loss angle | | 200% or less of the initial specified value | | | | | | | | | | | | | | | | | | | | | | | | | | | | | | | | | | | | | | | | | | | | | | | | | | | | | |
| Shelf life (105°C) | Test time : 1000 hours ; other items are the same as those for the endurance. Voltage application treatment : According to JIS C5101 -1 | | | | | | | | | | | | | | | | | | | | | | | | | | | | | | | | | | | | | | | | | | | | | | | | | | | | | | | |
| Applicable standards | JIS C5101-1, -4 1998 (IEC 60384-1 1992, -4 1985) | | | | | | | | | | | | | | | | | | | | | | | | | | | | | | | | | | | | | | | | | | | | | | | | | | | | | | | |

Outline Drawing

Unit : mm

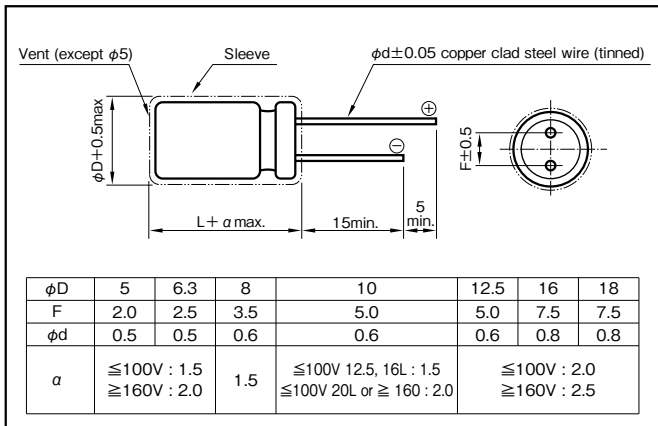

Coefficient of Frequency for Rated Ripple Current

| Rated voltage (V) | Rated capacitance (µF) | Frequency (Hz) | | | | |
|-------------------|------------------------|----------------|-----|-----|-----|------|
| | | 50 · 60 | 120 | 1k | 10k | 100k |
| 6.3 to 100 | 1 to 47 | 0.8 | 1 | 1.5 | 1.7 | 2.0 |
| | 100 to 220 | 0.8 | 1 | 1.2 | 1.3 | 1.4 |
| | 330 to 1000 | 0.8 | 1 | 1.2 | 1.2 | 1.3 |
| | 2200 to 22000 | 0.8 | 1 | 1.1 | 1.1 | 1.1 |
| 160 to 450 | 1 to 470 | 0.8 | 1 | 1.3 | 1.4 | 1.6 |

Part numbering system (example : 10V1000µF)

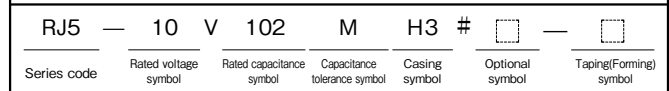

In the case of 160V or beyond, should put in optional symbol "B".

Casing symbol

| Size φD×L (mm) | Casing Symbol | Size φD×L (mm) | Casing Symbol | Size φD×L (mm) | Casing Symbol | Size φD×L (mm) | Casing Symbol |
|----------------|---------------|----------------|---------------|----------------|---------------|----------------|---------------|
| 5×11 | E3 | 10×12.5 | H3 | 16×20 | J5 | 18×20 | K5 |
| 6.3×11 | F3 | 10×16 | H4 | 16×25 | J6 | 18×25 | K6 |
| 8×11.5 | G3 | 10×20 | H5 | 16×31.5 | J7 | 18×31.5 | K7 |
| — | — | 12.5×20 | I5 | 16×35.5 | J8 | 18×35.5 | K8 |
| — | — | 12.5×25 | I6 | — | — | 18×40 | K9 |

Standard Ratings

| Rated voltage (V) | Item | 6.3 | | 10 | | 16 | | 25 | | 35 | | 50 | | 63 | | 100 | |
|-------------------|---------|-----------|----------------------|-----------|----------------------|-----------|----------------------|-----------|----------------------|-----------|----------------------|-----------|----------------------|-----------|----------------------|-----------|----------------------|
| | | Case | Rated ripple current | Case | Rated ripple current | Case | Rated ripple current | Case | Rated ripple current | Case | Rated ripple current | Case | Rated ripple current | Case | Rated ripple current | Case | Rated ripple current |
| | | φD×L (mm) | mArms | φD×L (mm) | mArms | φD×L (mm) | mArms | φD×L (mm) | mArms | φD×L (mm) | mArms | φD×L (mm) | mArms | φD×L (mm) | mArms | φD×L (mm) | mArms |
| 1 | — | — | — | — | — | — | — | — | — | — | — | 5×11 | 15 | — | — | 5×11 | 15 |
| 2.2 | — | — | — | — | — | — | — | — | — | — | — | 5×11 | 22 | — | — | 5×11 | 21 |
| 3.3 | — | — | — | — | — | — | — | — | — | — | — | 5×11 | 27 | — | — | 5×11 | 29 |
| 4.7 | — | — | — | — | — | — | — | — | — | — | — | 5×11 | 32 | — | — | 5×11 | 32 |
| 10 | — | — | — | — | — | — | — | — | — | — | — | 5×11 | 47 | — | — | 5×11 | 50 |
| 22 | — | — | — | — | — | — | — | — | — | — | — | 5×11 | 70 | 5×11 | 71 | 6.3×11 | 93 |
| 33 | — | — | — | — | — | — | — | — | — | — | — | 5×11 | 90 | 6.3×11 | 100 | 8×11.5 | 130 |
| 47 | — | — | — | — | — | — | — | — | — | 5×11 | 93 | 6.3×11 | 115 | 6.3×11 | 120 | 8×11.5 | 140 |
| 68 | — | — | — | — | — | — | — | — | — | 6.3×11 | 110 | 6.3×11 | 150 | 8×11.5 | 155 | 10×12.5 | 190 |
| 100 | — | — | — | — | — | — | — | 5×11 | 125 | 6.3×11 | 151 | 8×11.5 | 190 | 8×11.5 | 200 | 10×16 | 240 |
| 220 | — | — | 5×11 | 155 | 6.3×11 | 190 | 6.3×11 | 200 | 8×11.5 | 270 | 10×12.5 | 314 | 10×16 | 335 | 12.5×20 | 390 | |
| 330 | — | — | 6.3×11 | 210 | 6.3×11 | 225 | 8×11.5 | 310 | 10×12.5 | 384 | 10×16 | 421 | 10×20 | 510 | — | — | |
| 470 | — | — | 6.3×11 | 250 | 8×11.5 | 323 | 10×12.5 | 429 | 10×16 | 470 | 10×20 | 540 | 12.5×20 | 640 | 16×25 | 715 | |
| 1000 | 8×11.5 | 398 | 10×12.5 | 460 | 10×12.5 | 500 | 10×16 | 610 | 12.5×20 | 857 | 12.5×25 | 1000 | 16×25 | 930 | 18×35.5 | 960 | |
| 2200 | 10×16 | 635 | 10×16 | 705 | 10×20 | 710 | 12.5×25 | 1180 | 16×25 | 1380 | 16×31.5 | 1410 | 18×35.5 | 1650 | — | — | |
| 3300 | 10×20 | 882 | 12.5×20 | 1010 | 12.5×25 | 1200 | 16×25 | 1440 | 16×31.5 | 1500 | 18×35.5 | 1990 | — | — | — | — | |
| 4700 | 12.5×20 | 1120 | 12.5×25 | 1260 | 16×25 | 1500 | 16×25 | 1570 | 16×35.5 | 1780 | — | — | — | — | — | — | |
| 6800 | 12.5×25 | 1380 | 16×25 | 1570 | 16×25 | 1600 | 16×35.5 | 1850 | 18×40 | 2000 | — | — | — | — | — | — | |
| 10000 | 16×25 | 1750 | 16×31.5 | 1820 | 16×35.5 | 1930 | 18×40 | 2000 | — | — | — | — | — | — | — | — | |
| 15000 | 16×31.5 | 1820 | 16×35.5 | 2050 | 18×40 | 2210 | — | — | — | — | — | — | — | — | — | — | |
| 22000 | 18×35.5 | 2280 | 18×40 | 2420 | — | — | — | — | — | — | — | — | — | — | — | — | |

| Rated voltage (V) | Item | 160 | | 200 | | 250 | | 315 | | 350 | | 400 | | 450 | |
|-------------------|---------|-----------|----------------------|-----------|----------------------|-----------|----------------------|-----------|----------------------|-----------|----------------------|-----------|----------------------|-----------|----------------------|
| | | Case | Rated ripple current | Case | Rated ripple current | Case | Rated ripple current | Case | Rated ripple current | Case | Rated ripple current | Case | Rated ripple current | Case | Rated ripple current |
| | | φD×L (mm) | (mArms) | φD×L (mm) | (mArms) | φD×L (mm) | (mArms) | φD×L (mm) | (mArms) | φD×L (mm) | (mArms) | φD×L (mm) | (mArms) | φD×L (mm) | (mArms) |
| 1 | — | — | — | — | — | — | — | — | — | — | — | — | — | 6.3×11 | 12 |
| 2.2 | — | — | — | — | — | — | — | 6.3×11 | 21 | 6.3×11 | 21 | — | — | 8×11.5 | 20 |
| 3.3 | — | — | — | — | — | 6.3×11 | 35 | 6.3×11 | 26 | 6.3×11 | 26 | — | — | 10×12.5 | 41 |
| 4.7 | — | — | 6.3×11 | 42 | 6.3×11 | 42 | 8×11.5 | 35 | 8×11.5 | 35 | 8×11.5 | 35 | 10×12.5 | 49 | |
| 10 | 6.3×11 | 61 | 8×11.5 | 72 | 8×11.5 | 72 | 10×16 | 74 | 10×16 | 67 | 10×16 | 67 | 10×20 | 86 | |
| 22 | 10×12.5 | 125 | 10×16 | 135 | 10×16 | 135 | 12.5×20 | 135 | 12.5×20 | 140 | 12.5×20 | 140 | 12.5×25 | 170 | |
| 33 | 10×16 | 170 | 10×20 | 185 | 12.5×20 | 210 | 12.5×25 | 195 | 12.5×25 | 195 | 12.5×25 | 195 | 16×20 | 225 | |
| 47 | 10×20 | 220 | — | — | 12.5×20 | 250 | — | — | — | — | 16×25 | 350 | 16×25 | 296 | |
| 68 | 12.5×25 | 330 | 12.5×20 | 305 | 16×20 | 355 | 18×20 | 350 | 16×31.5 | 390 | 16×31.5 | 460 | 16×31.5 | 390 | |
| 100 | 16×20 | 430 | 12.5×25 | 400 | 16×25 | 465 | 16×35.5 | 500 | 16×35.5 | 500 | 18×25 | 380 | 18×25 | 380 | |
| 120 | 16×25 | 510 | 16×20 | 430 | 18×20 | 465 | 18×25 | 460 | 18×25 | 460 | 18×31.5 | 505 | 18×35.5 | 540 | |
| 150 | 18×20 | 510 | 16×25 | 510 | 16×31.5 | 560 | 18×31.5 | 560 | 18×31.5 | 560 | 18×35.5 | 588 | 18×40 | 615 | |
| 180 | 16×25 | 570 | 16×31.5 | 625 | 16×35.5 | 655 | 18×35.5 | 648 | 18×35.5 | 648 | 18×40 | 688 | — | — | |
| 220 | 18×20 | 570 | 18×25 | 615 | 18×25 | 615 | — | — | — | — | — | — | — | — | |
| 330 | 18×25 | 675 | 16×31.5 | 685 | 18×31.5 | 735 | 18×40 | 750 | — | — | — | — | — | — | |
| 470 | 18×25 | 745 | 18×25 | 675 | 16×35.5 | 790 | 18×35.5 | 855 | — | — | — | — | — | — | |
| 1000 | — | — | 18×31.5 | 810 | — | — | — | — | — | — | — | — | — | — | |
| 2200 | — | — | 18×40 | 1090 | — | — | — | — | — | — | — | — | — | — | |
| 3300 | 18×40 | 1300 | — | — | — | — | — | — | — | — | — | — | — | — | |

(Note) Rated ripple current : 105° C, 120Hz ; ESR. : 20° C, 120Hz

105°C Miniature Capacitors

GREEN CAP **105°C** **2000hours** **Anti-cleaning solvent 250V Max.**

- Case size is one rank smaller than Series RJ3.
- Guarantees 2000 hours at 105°C. (φ5 to φ8 : 1000 hours)

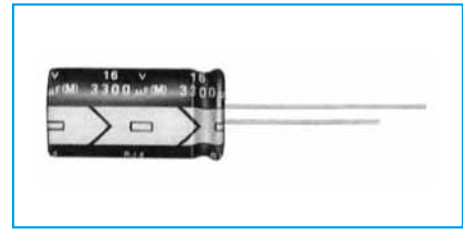
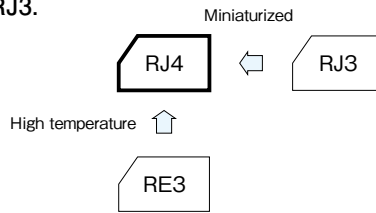

Marking color : White print on a black sleeve

Specifications

| Item | Performance | | | | | | | | | | | | | | | | | | | | | | | | | | | | | | | | | | | | | | | | | | | | | | | | | | | | | | | | | | | | | | | | | | | | | | | | | | | | | | | | | | | |
|---|--|--|------|------|------|------|------|------|------------|------------|------|------|------|------|------|--|-------------------|------------------------------------|----|----|----|----|----|----|-----|------------|------------|------------------------|---------------|-----|-----|-----|--------------|-----------------|-------------------------------------|------|------|------|---------------|------|------|------|------|------|------|------|------|------|--|--|----------------------------------|------------------------------|--|--|--|--|--|--|--|--|--|--|--|--|--|--|--|---------------------------|---|--|--|--|--|--|--|--|--|--|--|--|--|--|--|--|
| Category temperature range (°C) | -55 to +105 | -40 to +105 | | | | | | | | | | | | | | | | | | | | | | | | | | | | | | | | | | | | | | | | | | | | | | | | | | | | | | | | | | | | | | | | | | | | | | | | | | | | | | | | | | |
| Rated voltage (V) | 6.3 to 100 | 160 to 450 | | | | | | | | | | | | | | | | | | | | | | | | | | | | | | | | | | | | | | | | | | | | | | | | | | | | | | | | | | | | | | | | | | | | | | | | | | | | | | | | | | |
| Tolerance at rated capacitance (%) | ±20 (20°C, 120Hz) | | | | | | | | | | | | | | | | | | | | | | | | | | | | | | | | | | | | | | | | | | | | | | | | | | | | | | | | | | | | | | | | | | | | | | | | | | | | | | | | | | | |
| Leakage current (µA) | Less than 0.03CV or 4 whichever is larger (after 1 minute) Less than 0.01CV or 3 whichever is larger (after 2 minutes) | CV ≤ 1000 : Less than 0.1CV+40 (after 1 minute) CV > 1000 : Less than 0.04CV+100 (after 1 minute) | | | | | | | | | | | | | | | | | | | | | | | | | | | | | | | | | | | | | | | | | | | | | | | | | | | | | | | | | | | | | | | | | | | | | | | | | | | | | | | | | | |
| | C : Rated capacitance (µF) ; V : Rated voltage (V) (20°C) | | | | | | | | | | | | | | | | | | | | | | | | | | | | | | | | | | | | | | | | | | | | | | | | | | | | | | | | | | | | | | | | | | | | | | | | | | | | | | | | | | | |
| Tangent of loss angle (tanδ) | <table border="1"> <thead> <tr> <th>Rated voltage (V)</th> <th>6.3</th><th>10</th><th>16</th><th>25</th><th>35</th><th>50</th><th>63</th><th>100</th><th>160</th><th>200</th><th>250</th><th>315</th><th>350</th><th>400</th><th>450</th> </tr> </thead> <tbody> <tr> <td>tan δ (max.)</td> <td>0.28</td><td>0.24</td><td>0.20</td><td>0.16</td><td>0.14</td><td>0.12</td><td>0.10</td><td>0.08</td><td>0.20</td><td>0.20</td><td>0.20</td><td>0.24</td><td>0.24</td><td>0.24</td><td>0.24</td> </tr> </tbody> </table> <p>0.02 is added to every 1000µF increase over 1000µF. (20°C, 120Hz)</p> | | | | | | | | | | | | | | | | Rated voltage (V) | 6.3 | 10 | 16 | 25 | 35 | 50 | 63 | 100 | 160 | 200 | 250 | 315 | 350 | 400 | 450 | tan δ (max.) | 0.28 | 0.24 | 0.20 | 0.16 | 0.14 | 0.12 | 0.10 | 0.08 | 0.20 | 0.20 | 0.20 | 0.24 | 0.24 | 0.24 | 0.24 | | | | | | | | | | | | | | | | | | | | | | | | | | | | | | | | | | | | |
| Rated voltage (V) | 6.3 | 10 | 16 | 25 | 35 | 50 | 63 | 100 | 160 | 200 | 250 | 315 | 350 | 400 | 450 | | | | | | | | | | | | | | | | | | | | | | | | | | | | | | | | | | | | | | | | | | | | | | | | | | | | | | | | | | | | | | | | | | | | | |
| tan δ (max.) | 0.28 | 0.24 | 0.20 | 0.16 | 0.14 | 0.12 | 0.10 | 0.08 | 0.20 | 0.20 | 0.20 | 0.24 | 0.24 | 0.24 | 0.24 | | | | | | | | | | | | | | | | | | | | | | | | | | | | | | | | | | | | | | | | | | | | | | | | | | | | | | | | | | | | | | | | | | | | | |
| Characteristics at high and low temperature | <table border="1"> <thead> <tr> <th>Rated voltage (V)</th> <th>6.3</th><th>10</th><th>16</th><th>25</th><th>35</th><th>50</th><th>63</th><th>100</th><th>160 to 250</th><th>315 to 450</th> </tr> </thead> <tbody> <tr> <td rowspan="2">Impedance ratio (max.)</td> <td>Z-25°C/Z+20°C</td> <td>5</td><td>4</td><td>3</td><td>2</td><td>2</td><td>2</td><td>2</td><td>4</td><td>4</td> </tr> <tr> <td>Z-40°C/Z+20°C</td> <td>10</td><td>8</td><td>6</td><td>4</td><td>3</td><td>3</td><td>3</td><td>15</td><td>10</td> </tr> </tbody> </table> <p>(120Hz)</p> | | | | | | | | | | | | | | | | Rated voltage (V) | 6.3 | 10 | 16 | 25 | 35 | 50 | 63 | 100 | 160 to 250 | 315 to 450 | Impedance ratio (max.) | Z-25°C/Z+20°C | 5 | 4 | 3 | 2 | 2 | 2 | 2 | 4 | 4 | Z-40°C/Z+20°C | 10 | 8 | 6 | 4 | 3 | 3 | 3 | 15 | 10 | | | | | | | | | | | | | | | | | | | | | | | | | | | | | | | | | | | | |
| Rated voltage (V) | 6.3 | 10 | 16 | 25 | 35 | 50 | 63 | 100 | 160 to 250 | 315 to 450 | | | | | | | | | | | | | | | | | | | | | | | | | | | | | | | | | | | | | | | | | | | | | | | | | | | | | | | | | | | | | | | | | | | | | | | | | | |
| Impedance ratio (max.) | Z-25°C/Z+20°C | 5 | 4 | 3 | 2 | 2 | 2 | 2 | 4 | 4 | | | | | | | | | | | | | | | | | | | | | | | | | | | | | | | | | | | | | | | | | | | | | | | | | | | | | | | | | | | | | | | | | | | | | | | | | | |
| | Z-40°C/Z+20°C | 10 | 8 | 6 | 4 | 3 | 3 | 3 | 15 | 10 | | | | | | | | | | | | | | | | | | | | | | | | | | | | | | | | | | | | | | | | | | | | | | | | | | | | | | | | | | | | | | | | | | | | | | | | | | |
| Endurance (105°C) (Applied ripple current) | <table border="1"> <thead> <tr> <th>Test time</th> <td colspan="16">2000 hours (φ5 to φ8 : 1000 hours)</td> </tr> <tr> <th>Leakage current</th> <td colspan="16">The initial specified value or less</td> </tr> <tr> <th>Percentage of capacitance change</th> <td colspan="16">Within ±20% of initial value</td> </tr> <tr> <th>Tangent of the loss angle</th> <td colspan="16">200% or less of the initial specified value</td> </tr> </thead> </table> | | | | | | | | | | | | | | | | Test time | 2000 hours (φ5 to φ8 : 1000 hours) | | | | | | | | | | | | | | | | Leakage current | The initial specified value or less | | | | | | | | | | | | | | | | Percentage of capacitance change | Within ±20% of initial value | | | | | | | | | | | | | | | | Tangent of the loss angle | 200% or less of the initial specified value | | | | | | | | | | | | | | | |
| Test time | 2000 hours (φ5 to φ8 : 1000 hours) | | | | | | | | | | | | | | | | | | | | | | | | | | | | | | | | | | | | | | | | | | | | | | | | | | | | | | | | | | | | | | | | | | | | | | | | | | | | | | | | | | | |
| Leakage current | The initial specified value or less | | | | | | | | | | | | | | | | | | | | | | | | | | | | | | | | | | | | | | | | | | | | | | | | | | | | | | | | | | | | | | | | | | | | | | | | | | | | | | | | | | | |
| Percentage of capacitance change | Within ±20% of initial value | | | | | | | | | | | | | | | | | | | | | | | | | | | | | | | | | | | | | | | | | | | | | | | | | | | | | | | | | | | | | | | | | | | | | | | | | | | | | | | | | | | |
| Tangent of the loss angle | 200% or less of the initial specified value | | | | | | | | | | | | | | | | | | | | | | | | | | | | | | | | | | | | | | | | | | | | | | | | | | | | | | | | | | | | | | | | | | | | | | | | | | | | | | | | | | | |
| Shelf life (105°C) | Test time : 1000 hours ; other items are the same as those for the endurance. Voltage application treatment | | | | | | | | | | | | | | | | | | | | | | | | | | | | | | | | | | | | | | | | | | | | | | | | | | | | | | | | | | | | | | | | | | | | | | | | | | | | | | | | | | | |
| Applicable standards | JIS C5101-1, -4 1998 (IEC 60384-1 1992, -4 1985) | | | | | | | | | | | | | | | | | | | | | | | | | | | | | | | | | | | | | | | | | | | | | | | | | | | | | | | | | | | | | | | | | | | | | | | | | | | | | | | | | | | |

Outline Drawing

Unit : mm

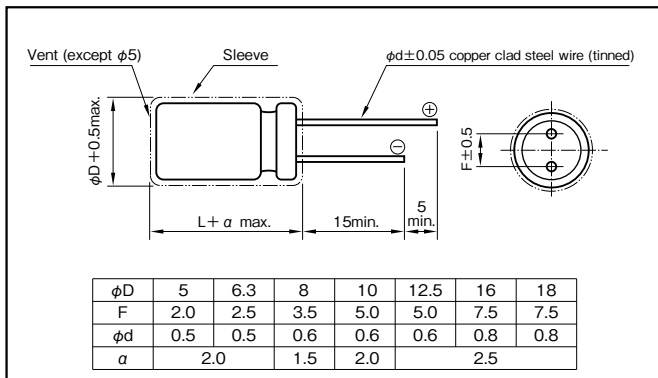

Coefficient of Frequency for Rated Ripple Current

| Rated voltage (V) | Rated capacitance (µF) | Frequency (Hz) | | | | |
|-------------------|------------------------|----------------|-----|-----|-----|------|
| | | 50 · 60 | 120 | 1k | 10k | 100k |
| 6.3 to 100 | 1 to 47 | 0.8 | 1 | 1.5 | 1.7 | 2.0 |
| | 100 to 220 | 0.8 | 1 | 1.2 | 1.3 | 1.4 |
| | 330 to 1000 | 0.8 | 1 | 1.2 | 1.2 | 1.3 |
| | 2200 to 22000 | 0.8 | 1 | 1.1 | 1.1 | 1.1 |
| 160 to 450 | 1 to 330 | 0.8 | 1 | 1.3 | 1.4 | 1.6 |

Part numbering system (example : 16V2200µF)

| | | | | | | | | | | |
|-------------|---|----------------------|---|--------------------------|------------------------------|---------------|-----------------|---|---|-----------------------|
| RJ4 | — | 16 | V | 222 | M | I5 | # | □ | — | □ |
| Series code | | Rated voltage symbol | | Rated capacitance symbol | Capacitance tolerance symbol | Casing symbol | Optional symbol | | | Taping/Forming symbol |

Casing symbol

| Size φD×L (mm) | Casing Symbol | Size φD×L (mm) | Casing Symbol |
|----------------|---------------|----------------|---------------|
| 5×11 | E3 | 12.5×25 | I6 |
| 6.3×11 | F3 | 16×25 | J6 |
| 8×11.5 | G3 | 16×31.5 | J7 |
| 10×12.5 | H3 | 16×35.5 | J8 |
| 10×16 | H4 | 18×31.5 | K7 |
| 10×20 | H5 | 18×35.5 | K8 |
| 12.5×20 | I5 | 18×40 | K9 |

Standard Ratings

| Rated voltage (V) | Item | 6.3 | | | 10 | | | 16 | | | 25 | | | 35 | | | 50 | | | 63 | | | 100 | | | | | | | | | | | | |
|-------------------|---------|-----------|------|----------------------|-----------|------|----------------------|-----------|------|----------------------|-----------|------|----------------------|-----------|------|----------------------|-----------|------|----------------------|-----------|--------|----------------------|-----------|--------|----------------------|-----|--------|------|-----|---------|------|-----|---------|------|-----|
| | | Case | ESR | Rated ripple current | Case | ESR | Rated ripple current | Case | ESR | Rated ripple current | Case | ESR | Rated ripple current | Case | ESR | Rated ripple current | Case | ESR | Rated ripple current | Case | ESR | Rated ripple current | Case | ESR | Rated ripple current | | | | | | | | | | |
| | | φD×L (mm) | (Ω) | (mA _{rms}) | φD×L (mm) | (Ω) | (mA _{rms}) | φD×L (mm) | (Ω) | (mA _{rms}) | φD×L (mm) | (Ω) | (mA _{rms}) | φD×L (mm) | (Ω) | (mA _{rms}) | φD×L (mm) | (Ω) | (mA _{rms}) | φD×L (mm) | (Ω) | (mA _{rms}) | φD×L (mm) | (Ω) | (mA _{rms}) | | | | | | | | | | |
| 1 | — | — | — | — | — | — | — | — | — | — | — | — | — | — | — | 5×11 | 199 | 15 | — | — | — | 5×11 | 133 | 15 | | | | | | | | | | | |
| 2.2 | — | — | — | — | — | — | — | — | — | — | — | — | — | — | — | 5×11 | 90.5 | 22 | — | — | — | 5×11 | 60.3 | 21 | | | | | | | | | | | |
| 3.3 | — | — | — | — | — | — | — | — | — | — | — | — | — | — | — | 5×11 | 60.3 | 27 | — | — | — | 5×11 | 40.2 | 29 | | | | | | | | | | | |
| 4.7 | — | — | — | — | — | — | — | — | — | — | — | — | — | — | 5×11 | 56.5 | 27 | 5×11 | 49.4 | 30 | 5×11 | 42.4 | 32 | — | — | — | 5×11 | 28.2 | 32 | | | | | | |
| 10 | — | — | — | — | — | — | — | — | — | — | — | — | — | — | 5×11 | 33.2 | 37 | 5×11 | 26.5 | 39 | 5×11 | 23.2 | 43 | 5×11 | 19.9 | 47 | 5×11 | 16.6 | 46 | 6.3×11 | 13.3 | 54 | | | |
| 22 | — | — | — | — | — | — | — | — | — | — | — | — | — | — | 5×11 | 15.1 | 54 | 5×11 | 12.1 | 58 | 5×11 | 10.6 | 64 | 5×11 | 9.05 | 70 | 5×11 | 7.54 | 71 | 6.3×11 | 6.03 | 93 | | | |
| 33 | — | — | — | — | — | — | — | — | — | — | — | — | — | — | 5×11 | 10.1 | 67 | 5×11 | 8.04 | 71 | 5×11 | 7.04 | 78 | 5×11 | 6.03 | 90 | 6.3×11 | 5.03 | 100 | 8×11.5 | 4.02 | 130 | | | |
| 47 | — | — | — | — | — | — | — | — | — | — | — | — | — | — | 5×11 | 8.47 | 72 | 5×11 | 7.06 | 79 | 5×11 | 5.65 | 84 | 5×11 | 4.94 | 90 | 6.3×11 | 4.24 | 115 | 6.3×11 | 3.53 | 120 | 10×12.5 | 2.82 | 165 |
| 100 | — | — | — | — | — | — | — | — | — | — | — | — | — | — | 5×11 | 3.98 | 105 | 5×11 | 3.32 | 115 | 6.3×11 | 2.65 | 141 | 6.3×11 | 2.32 | 151 | 8×11.5 | 1.99 | 190 | 10×12.5 | 1.66 | 215 | 10×20 | 1.33 | 265 |
| 220 | 5×11 | 2.11 | 140 | 6.3×11 | 1.81 | 166 | 6.3×11 | 1.51 | 190 | 8×11.5 | 1.21 | 247 | 10×12.5 | 1.06 | 314 | 10×12.5 | 0.91 | 314 | 10×16 | 0.75 | 335 | 12.5×25 | 0.60 | 440 | | | | | | | | | | | |
| 330 | 6.3×11 | 1.41 | 195 | 6.3×11 | 1.21 | 210 | 8×11.5 | 1.01 | 271 | 10×12.5 | 0.81 | 360 | 10×12.5 | 0.70 | 384 | 10×16 | 0.60 | 421 | 10×20 | 0.50 | 510 | 12.5×25 | 0.40 | 540 | | | | | | | | | | | |
| 470 | 6.3×11 | 0.99 | 232 | 8×11.5 | 0.85 | 325 | 8×11.5 | 0.71 | 323 | 10×12.5 | 0.57 | 429 | 10×16 | 0.50 | 470 | 12.5×20 | 0.42 | 628 | 12.5×20 | 0.35 | 640 | 16×25 | 0.28 | 715 | | | | | | | | | | | |
| 1000 | 8×11.5 | 0.47 | 398 | 10×12.5 | 0.40 | 457 | 10×16 | 0.33 | 560 | 10×20 | 0.27 | 705 | 12.5×20 | 0.23 | 857 | 12.5×25 | 0.20 | 1000 | 16×25 | 0.17 | 930 | 18×40 | 0.13 | 985 | | | | | | | | | | | |
| 2200 | 10×20 | 0.23 | 720 | 10×20 | 0.20 | 761 | 12.5×20 | 0.17 | 961 | 12.5×25 | 0.14 | 1180 | 16×25 | 0.12 | 1380 | 16×35.5 | 0.11 | 1660 | — | — | — | — | — | — | | | | | | | | | | | |
| 3300 | 10×20 | 0.16 | 882 | 12.5×20 | 0.14 | 1010 | 12.5×25 | 0.12 | 1200 | 16×25 | 0.10 | 1440 | 16×35.5 | 0.09 | 1780 | 18×35.5 | 0.08 | 1990 | — | — | — | — | — | — | | | | | | | | | | | |
| 4700 | 12.5×20 | 0.12 | 1120 | 12.5×25 | 0.11 | 1250 | 16×25 | 0.09 | 1490 | 16×31.5 | 0.08 | 1880 | 18×35.5 | 0.07 | 2120 | — | — | — | — | — | — | — | — | — | | | | | | | | | | | |
| 6800 | 12.5×25 | 0.09 | 1380 | 16×25 | 0.08 | 1570 | 16×35.5 | 0.07 | 1830 | 18×35.5 | 0.06 | 2330 | — | — | — | — | — | — | — | — | — | — | — | — | | | | | | | | | | | |
| 10000 | 16×25 | 0.07 | 1750 | 16×35.5 | 0.07 | 1910 | 18×35.5 | 0.06 | 2220 | — | — | — | — | — | — | — | — | — | — | — | — | — | — | — | | | | | | | | | | | |
| 15000 | 16×35.5 | 0.06 | 2040 | 18×35.5 | 0.06 | 2190 | — | — | — | — | — | — | — | — | — | — | — | — | — | — | — | — | — | — | | | | | | | | | | | |
| 22000 | 18×40 | 0.05 | 2390 | — | — | — | — | — | — | — | — | — | — | — | — | — | — | — | — | — | — | — | — | — | | | | | | | | | | | |

| Rated voltage (V) | Item | 160 | | | 200 | | | 250 | | | 315 | | | 350 | | | 400 | | | 450 | | | |
|-------------------|---------|-----------|-----|----------------------|-----------|-----|----------------------|-----------|-----|----------------------|-----------|-----|----------------------|-----------|-----|----------------------|-----------|-----|----------------------|-----------|-----|----------------------|---|
| | | Case | ESR | Rated ripple current | Case | ESR | Rated ripple current | Case | ESR | Rated ripple current | Case | ESR | Rated ripple current | Case | ESR | Rated ripple current | Case | ESR | Rated ripple current | Case | ESR | Rated ripple current | |
| | | φD×L (mm) | (Ω) | (mA _{rms}) | φD×L (mm) | (Ω) | (mA _{rms}) | φD×L (mm) | (Ω) | (mA _{rms}) | φD×L (mm) | (Ω) | (mA _{rms}) | φD×L (mm) | (Ω) | (mA _{rms}) | φD×L (mm) | (Ω) | (mA _{rms}) | φD×L (mm) | (Ω) | (mA _{rms}) | |
| 0.47 | 6.3×11 | 706 | 11 | 6.3×11 | 706 | 11 | 6.3×11 | 706 | 11 | 6.3×11 | 847 | 11 | 6.3×11 | 847 | 11 | 6.3×11 | 847 | 11 | 8×11.5 | 847 | 13 | | |
| 1 | 6.3×11 | 332 | 16 | 6.3×11 | 332 | 16 | 6.3×11 | 332 | 16 | 6.3×11 | 398 | 16 | 6.3×11 | 398 | 16 | 6.3×11 | 398 | 16 | 8×11.5 | 398 | 18 | | |
| 2.2 | 6.3×11 | 151 | 23 | 6.3×11 | 151 | 23 | 6.3×11 | 151 | 23 | 8×11.5 | 181 | 27 | 8×11.5 | 181 | 27 | 8×11.5 | 181 | 27 | 10×12.5 | 181 | 31 | | |
| 3.3 | 6.3×11 | 101 | 28 | 6.3×11 | 101 | 28 | 8×11.5 | 101 | 34 | 10×12.5 | 121 | 38 | 10×12.5 | 121 | 38 | 10×12.5 | 121 | 38 | 10×16 | 121 | 42 | | |
| 4.7 | 6.3×11 | 70.6 | 34 | 8×11.5 | 70.6 | 40 | 8×11.5 | 70.6 | 40 | 10×12.5 | 84.7 | 45 | 10×12.5 | 84.7 | 45 | 10×16 | 84.7 | 50 | 10×20 | 84.7 | 54 | | |
| 10 | 8×11.5 | 33.2 | 58 | 10×12.5 | 33.2 | 66 | 10×16 | 33.2 | 74 | 10×20 | 39.8 | 79 | 10×20 | 39.8 | 79 | 12.5×20 | 39.8 | 87 | 12.5×20 | 39.8 | 87 | | |
| 22 | 10×16 | 15.1 | 107 | 10×20 | 15.1 | 120 | 12.5×20 | 15.1 | 130 | 12.5×20 | 18.1 | 129 | 12.5×25 | 18.1 | 140 | 12.5×25 | 18.1 | 140 | 16×25 | 18.1 | 160 | | |
| 33 | 10×20 | 10.1 | 143 | 12.5×20 | 10.1 | 160 | 12.5×25 | 10.1 | 172 | 16×25 | 12.1 | 196 | 16×25 | 12.1 | 196 | 16×25 | 12.1 | 196 | 16×31.5 | 12.1 | 215 | | |
| 47 | 12.5×20 | 7.06 | 188 | 12.5×20 | 7.06 | 188 | 12.5×25 | 7.06 | 205 | 16×25 | 8.47 | 234 | 16×25 | 8.47 | 234 | 16×31.5 | 8.47 | 256 | 16×35.5 | 8.47 | 269 | | |
| 100 | 12.5×25 | 3.32 | 299 | 16×25 | 3.32 | 342 | 16×31.5 | 3.32 | 374 | 18×31.5 | 3.98 | 401 | 18×31.5 | 3.98 | 401 | — | — | — | — | — | — | — | |
| 220 | 16×31.5 | 1.51 | 554 | 18×35.5 | 1.51 | 624 | — | — | — | — | — | — | — | — | — | — | — | — | — | — | — | — | |
| 330 | 18×35.5 | 1.01 | 764 | — | — | — | — | — | — | — | — | — | — | — | — | — | — | — | — | — | — | — | — |

(Note) Rated ripple current : 105°C, 120Hz ; ESR. : 20°C, 120Hz

105°C Use, Standard Capacitors

GREEN CAP 105°C 2000hours Anti-cleaning solvent 250V Max.

• Guarantees 2000 hours at 105°C (φ5 to φ8 : 1000 hours).

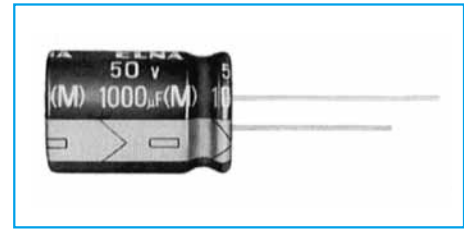
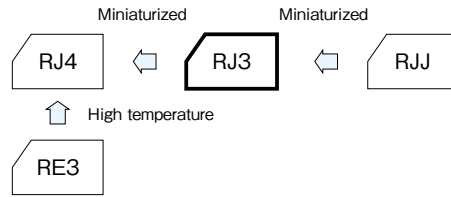

Marking color : White print on a black sleeve

Specifications

| Item | Performance | | | | | | | | | | | | | | | | | | | | | | | | | | | | | | | | | |
|---|---|-------------|-------------------|------------------------------------|-----------------|-------------------------------------|----------------------------------|------------------------------|---------------------------|---|------|------------|------------|------------------------|----------------|-----|-----|--------------|------|------|------|------|------|------|----------------|------|------|------|------|------|------|------|---|---|
| Category temperature range (°C) | -55 to +105 | -40 to +105 | | | | | | | | | | | | | | | | | | | | | | | | | | | | | | | | |
| Rated voltage (V) | 6.3 to 100 | 160 to 400 | | | | | | | | | | | | | | | | | | | | | | | | | | | | | | | | |
| Tolerance at rated capacitance (%) | ±20 (20°C, 120Hz) | | | | | | | | | | | | | | | | | | | | | | | | | | | | | | | | | |
| Leakage current (μA) | Less than 0.01CV or 3 whichever is larger (after 2 minutes) CV ≤ 1000 : Less than 0.1CV+40 (after 1 minute) CV > 1000 : Less than 0.04CV+100 (after 1 minute) C : Rated capacitance (μF) ; V : Rated voltage (V) (20°C) | | | | | | | | | | | | | | | | | | | | | | | | | | | | | | | | | |
| Tangent of loss angle (tanδ) | <table border="1"> <thead> <tr> <th>Rated voltage (V)</th> <th>6.3</th> <th>10</th> <th>16</th> <th>25</th> <th>35</th> <th>50</th> <th>63</th> <th>100</th> <th>160</th> <th>200</th> <th>250</th> <th>315</th> <th>350</th> <th>400</th> </tr> </thead> <tbody> <tr> <td>tan δ (max.)</td> <td>0.22</td> <td>0.19</td> <td>0.16</td> <td>0.14</td> <td>0.12</td> <td>0.10</td> <td>0.09</td> <td>0.08</td> <td>0.15</td> <td>0.15</td> <td>0.15</td> <td>0.20</td> <td>0.20</td> <td>0.20</td> </tr> </tbody> </table> <p>0.02 is added to every 1000μF increase over 1000μF. (20°C, 120Hz)</p> | | Rated voltage (V) | 6.3 | 10 | 16 | 25 | 35 | 50 | 63 | 100 | 160 | 200 | 250 | 315 | 350 | 400 | tan δ (max.) | 0.22 | 0.19 | 0.16 | 0.14 | 0.12 | 0.10 | 0.09 | 0.08 | 0.15 | 0.15 | 0.15 | 0.20 | 0.20 | 0.20 | | |
| Rated voltage (V) | 6.3 | 10 | 16 | 25 | 35 | 50 | 63 | 100 | 160 | 200 | 250 | 315 | 350 | 400 | | | | | | | | | | | | | | | | | | | | |
| tan δ (max.) | 0.22 | 0.19 | 0.16 | 0.14 | 0.12 | 0.10 | 0.09 | 0.08 | 0.15 | 0.15 | 0.15 | 0.20 | 0.20 | 0.20 | | | | | | | | | | | | | | | | | | | | |
| Characteristics at high and low temperature | <table border="1"> <thead> <tr> <th>Rated voltage (V)</th> <th>6.3</th> <th>10</th> <th>16</th> <th>25</th> <th>35</th> <th>50</th> <th>63</th> <th>100</th> <th>160 to 250</th> <th>315 to 450</th> </tr> </thead> <tbody> <tr> <td rowspan="2">Impedance ratio (max.)</td> <td>Z=-25°C/Z+20°C</td> <td>4</td> <td>3</td> <td>2</td> <td>2</td> <td>2</td> <td>2</td> <td>2</td> <td>3</td> <td>3</td> </tr> <tr> <td>Z=-55°C/Z+20°C</td> <td>8</td> <td>6</td> <td>4</td> <td>3</td> <td>3</td> <td>3</td> <td>3</td> <td>8</td> <td>6</td> </tr> </tbody> </table> <p>(120Hz)</p> | | Rated voltage (V) | 6.3 | 10 | 16 | 25 | 35 | 50 | 63 | 100 | 160 to 250 | 315 to 450 | Impedance ratio (max.) | Z=-25°C/Z+20°C | 4 | 3 | 2 | 2 | 2 | 2 | 2 | 3 | 3 | Z=-55°C/Z+20°C | 8 | 6 | 4 | 3 | 3 | 3 | 3 | 8 | 6 |
| Rated voltage (V) | 6.3 | 10 | 16 | 25 | 35 | 50 | 63 | 100 | 160 to 250 | 315 to 450 | | | | | | | | | | | | | | | | | | | | | | | | |
| Impedance ratio (max.) | Z=-25°C/Z+20°C | 4 | 3 | 2 | 2 | 2 | 2 | 2 | 3 | 3 | | | | | | | | | | | | | | | | | | | | | | | | |
| | Z=-55°C/Z+20°C | 8 | 6 | 4 | 3 | 3 | 3 | 3 | 8 | 6 | | | | | | | | | | | | | | | | | | | | | | | | |
| Endurance (105°C) (Applied ripple current) | <table border="1"> <thead> <tr> <th>Test time</th> <th>2000 hours (φ5 to φ8 : 1000 hours)</th> </tr> </thead> <tbody> <tr> <td>Leakage current</td> <td>The initial specified value or less</td> </tr> <tr> <td>Percentage of capacitance change</td> <td>Within ±20% of initial value</td> </tr> <tr> <td>Tangent of the loss angle</td> <td>200% or less of the initial specified value</td> </tr> </tbody> </table> | | Test time | 2000 hours (φ5 to φ8 : 1000 hours) | Leakage current | The initial specified value or less | Percentage of capacitance change | Within ±20% of initial value | Tangent of the loss angle | 200% or less of the initial specified value | | | | | | | | | | | | | | | | | | | | | | | | |
| Test time | 2000 hours (φ5 to φ8 : 1000 hours) | | | | | | | | | | | | | | | | | | | | | | | | | | | | | | | | | |
| Leakage current | The initial specified value or less | | | | | | | | | | | | | | | | | | | | | | | | | | | | | | | | | |
| Percentage of capacitance change | Within ±20% of initial value | | | | | | | | | | | | | | | | | | | | | | | | | | | | | | | | | |
| Tangent of the loss angle | 200% or less of the initial specified value | | | | | | | | | | | | | | | | | | | | | | | | | | | | | | | | | |
| Shelf life (105°C) | Test time : 1000 hours; other items are the same as those for the endurance. Voltage application treatment : According to JIS C5101-1 | | | | | | | | | | | | | | | | | | | | | | | | | | | | | | | | | |
| Applicable standards | JIS C5101-1, -4 1998 (IEC 60384-1 1992, -4 1985) | | | | | | | | | | | | | | | | | | | | | | | | | | | | | | | | | |

Outline Drawing

Unit : mm

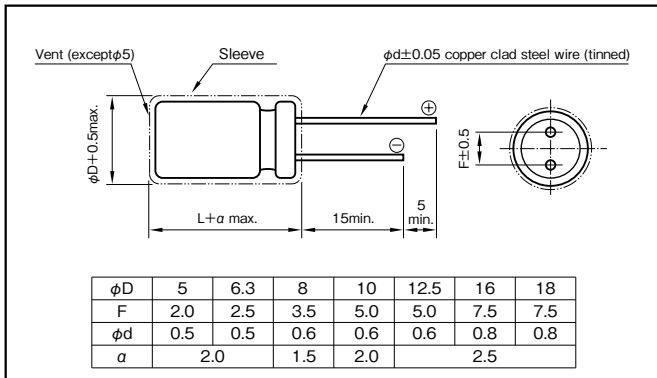

Coefficient of Frequency for Rated Ripple Current

| Rated voltage (V) | Rated capacitance (μF) | Frequency (Hz) | | | | |
|-------------------|------------------------|----------------|-----|-----|-----|------|
| | | 50 · 60 | 120 | 1k | 10k | 100k |
| 6.3 to 100 | 1 to 4.7 | — | 0.4 | 0.7 | 0.8 | 1 |
| | 10 to 47 | — | 0.5 | 0.8 | 0.9 | 1 |
| | 100 to 220 | — | 0.7 | 0.9 | 0.9 | 1 |
| | 330 to 1000 | — | 0.8 | 0.9 | 1.0 | 1 |
| | 2200 to 15000 | — | 0.9 | 1.0 | 1.0 | 1 |
| 160 to 400 | 0.47 to 220 | 0.8 | 1 | 1.3 | 1.4 | 1.6 |

Part numbering system (example : 63V1000μF)

| | | | | | | | | | | |
|-------------|---|----------------------|---|--------------------------|------------------------------|---------------|-----------------|---|---|-----------------------|
| RJ3 | — | 63 | V | 102 | M | J7 | # | □ | — | □ |
| Series code | | Rated voltage symbol | | Rated capacitance symbol | Capacitance tolerance symbol | Casing symbol | Optional symbol | | | Taping/Forming symbol |

Casing symbol

| Size φD×L (mm) | Casing Symbol | Size φD×L (mm) | Casing Symbol |
|----------------|---------------|----------------|---------------|
| 5×11 | E3 | 12.5×25 | I6 |
| 6.3×11 | F3 | 16×25 | J6 |
| 8×11.5 | G3 | 16×31.5 | J7 |
| 10×12.5 | H3 | 16×35.5 | J8 |
| 10×16 | H4 | 18×35.5 | K8 |
| 10×20 | H5 | 18×40 | K9 |
| 12.5×20 | I5 | | |

Standard Ratings

| Rated voltage (V) | Item | 6.3 | | | | 10 | | | | 16 | | | | 25 | | | |
|-------------------|---------|-----------|-------|-----------|----------------------|-----------|-------|-----------|----------------------|-----------|-------|-----------|----------------------|-----------|-------|-----------|----------------------|
| | | Case | ESR | Impedance | Rated ripple current | Case | ESR | Impedance | Rated ripple current | Case | ESR | Impedance | Rated ripple current | Case | ESR | Impedance | Rated ripple current |
| | | φD×L (mm) | (Ω) | (Ω max.) | (mAmps) | φD×L (mm) | (Ω) | (Ω max.) | (mAmps) | φD×L (mm) | (Ω) | (Ω max.) | (mAmps) | φD×L (mm) | (Ω) | (Ω max.) | (mAmps) |
| 4.7 | — | — | — | — | — | — | — | — | — | — | — | — | — | — | — | — | — |
| 10 | — | — | — | — | — | — | — | — | — | 5×11 | 26.5 | 2.5 | 92 | 5×11 | 23.2 | 2.5 | 92 |
| 22 | — | — | — | — | 5×11 | 14.3 | 2.5 | 92 | 5×11 | 12.1 | 1.9 | 105 | 5×11 | 10.6 | 1.9 | 105 | |
| 33 | 5×11 | 11.1 | 2.5 | 105 | 5×11 | 9.55 | 1.9 | 105 | 5×11 | 8.04 | 1.5 | 120 | 5×11 | 7.04 | 1.5 | 120 | |
| 47 | 5×11 | 7.77 | 1.5 | 120 | 5×11 | 6.71 | 1.5 | 120 | 5×11 | 5.65 | 1.2 | 130 | 5×11 | 4.94 | 1.2 | 130 | |
| 100 | 5×11 | 3.65 | 1.2 | 130 | 5×11 | 3.15 | 1.2 | 130 | 6.3×11 | 2.65 | 0.58 | 220 | 6.3×11 | 2.32 | 0.58 | 220 | |
| 220 | 6.3×11 | 1.66 | 0.87 | 180 | 6.3×11 | 1.43 | 0.58 | 220 | 8×11.5 | 1.21 | 0.47 | 290 | 8×11.5 | 1.06 | 0.39 | 315 | |
| 330 | 6.3×11 | 1.11 | 0.58 | 220 | 8×11.5 | 0.96 | 0.47 | 265 | 8×11.5 | 0.81 | 0.39 | 315 | 10×12.5 | 0.70 | 0.23 | 500 | |
| 470 | 8×11.5 | 0.78 | 0.39 | 315 | 8×11.5 | 0.67 | 0.39 | 315 | 10×12.5 | 0.57 | 0.23 | 500 | 10×16 | 0.50 | 0.18 | 615 | |
| 1000 | 10×12.5 | 0.37 | 0.23 | 500 | 10×16 | 0.32 | 0.18 | 615 | 10×20 | 0.27 | 0.12 | 825 | 12.5×20 | 0.23 | 0.090 | 1050 | |
| 2200 | 12.5×20 | 0.18 | 0.095 | 1000 | 12.5×20 | 0.16 | 0.090 | 1050 | 12.5×25 | 0.14 | 0.068 | 1300 | 16×25 | 0.12 | 0.056 | 1740 | |
| 3300 | 12.5×20 | 0.13 | 0.090 | 1050 | 12.5×25 | 0.12 | 0.068 | 1300 | 16×25 | 0.10 | 0.056 | 1740 | 16×31.5 | 0.09 | 0.045 | 2110 | |
| 4700 | 16×25 | 0.10 | 0.061 | 1670 | 16×25 | 0.09 | 0.056 | 1740 | 16×31.5 | 0.08 | 0.045 | 2110 | 18×35.5 | 0.07 | 0.036 | 2580 | |
| 6800 | 16×25 | 0.08 | 0.056 | 1740 | 16×31.5 | 0.07 | 0.045 | 2110 | 18×35.5 | 0.06 | 0.036 | 2580 | — | — | — | — | |
| 10000 | 16×31.5 | 0.06 | 0.045 | 2110 | 18×35.5 | 0.06 | 0.036 | 2580 | — | — | — | — | — | — | — | — | |
| 15000 | 18×35.5 | 0.05 | 0.036 | 2580 | — | — | — | — | — | — | — | — | — | — | — | — | |

| Rated voltage (V) | Item | 35 | | | | 50 | | | | 63 | | | | 100 | | | |
|-------------------|---------|-----------|-------|-----------|----------------------|-----------|-------|-----------|----------------------|-----------|-------|-----------|----------------------|-----------|------|-----------|----------------------|
| | | Case | ESR | Impedance | Rated ripple current | Case | ESR | Impedance | Rated ripple current | Case | ESR | Impedance | Rated ripple current | Case | ESR | Impedance | Rated ripple current |
| | | φD×L (mm) | (Ω) | (Ω max.) | (mAmps) | φD×L (mm) | (Ω) | (Ω max.) | (mAmps) | φD×L (mm) | (Ω) | (Ω max.) | (mAmps) | φD×L (mm) | (Ω) | (Ω max.) | (mAmps) |
| 1 | — | — | — | — | 5×11 | 166 | 4.9 | 35 | — | — | — | — | 5×11 | 133 | 11 | 45 | |
| 2.2 | — | — | — | — | 5×11 | 75.4 | 4.2 | 53 | — | — | — | — | 5×11 | 60.3 | 9.2 | 60 | |
| 3.3 | — | — | — | — | 5×11 | 50.3 | 3.9 | 65 | — | — | — | — | 5×11 | 40.2 | 7.2 | 67 | |
| 4.7 | 5×11 | 42.4 | 2.5 | 92 | 5×11 | 35.3 | 3.6 | 82 | 5×11 | 31.8 | 5.8 | 74 | 5×11 | 28.2 | 6.3 | 75 | |
| 10 | 5×11 | 19.9 | 1.9 | 105 | 5×11 | 16.6 | 2.7 | 100 | 5×11 | 14.9 | 3.6 | 95 | 6.3×11 | 13.3 | 3.3 | 110 | |
| 22 | 5×11 | 9.05 | 1.5 | 120 | 5×11 | 7.54 | 1.9 | 125 | 6.3×11 | 6.79 | 2.1 | 130 | 8×11.5 | 6.03 | 1.4 | 165 | |
| 33 | 5×11 | 6.03 | 1.2 | 130 | 6.3×11 | 5.03 | 1.1 | 195 | 6.3×11 | 4.52 | 1.7 | 160 | 10×12.5 | 4.02 | 0.94 | 305 | |
| 47 | 6.3×11 | 4.24 | 0.58 | 220 | 6.3×11 | 3.53 | 0.90 | 245 | 8×11.5 | 3.18 | 1.2 | 305 | 10×16 | 2.82 | 0.68 | 320 | |
| 100 | 8×11.5 | 1.99 | 0.39 | 315 | 8×11.5 | 1.66 | 0.50 | 385 | 10×12.5 | 1.49 | 0.65 | 395 | 12.5×20 | 1.33 | 0.28 | 585 | |
| 220 | 10×12.5 | 0.91 | 0.23 | 500 | 10×16 | 0.75 | 0.27 | 505 | 10×20 | 0.68 | 0.32 | 505 | 16×25 | 0.60 | 0.16 | 1120 | |
| 330 | 10×16 | 0.60 | 0.18 | 615 | 10×20 | 0.50 | 0.18 | 675 | 12.5×20 | 0.45 | 0.22 | 660 | 16×25 | 0.40 | 0.13 | 1290 | |
| 470 | 10×20 | 0.42 | 0.12 | 825 | 12.5×20 | 0.35 | 0.12 | 895 | 12.5×25 | 0.32 | 0.16 | 850 | 16×31.5 | 0.28 | 0.11 | 1350 | |
| 1000 | 12.5×25 | 0.20 | 0.068 | 1300 | 16×25 | 0.17 | 0.076 | 1495 | 16×31.5 | 0.15 | 0.098 | 1430 | — | — | — | — | |
| 2200 | 16×31.5 | 0.11 | 0.045 | 2110 | 18×35.5 | 0.09 | 0.050 | 2190 | — | — | — | — | — | — | — | — | |
| 3300 | 18×35.5 | 0.08 | 0.036 | 2580 | — | — | — | — | — | — | — | — | — | — | — | — | |

(Note) Rated ripple current : 105°C, 100kHz ; ESR. : 20°C, 120Hz ; Impedance : 20°C, 100kHz

| Rated voltage (V) | Item | 160 | | | 200 | | | 250 | | | 315 | | | 350 | | | 400 | | |
|-------------------|---------|-----------|-----|----------------------|-----------|-----|----------------------|-----------|-----|----------------------|-----------|-----|----------------------|-----------|-----|----------------------|-----------|-----|----------------------|
| | | Case | ESR | Rated ripple current | Case | ESR | Rated ripple current | Case | ESR | Rated ripple current | Case | ESR | Rated ripple current | Case | ESR | Rated ripple current | Case | ESR | Rated ripple current |
| | | φD×L (mm) | (Ω) | (mAmps) | φD×L (mm) | (Ω) | (mAmps) | φD×L (mm) | (Ω) | (mAmps) | φD×L (mm) | (Ω) | (mAmps) | φD×L (mm) | (Ω) | (mAmps) | φD×L (mm) | (Ω) | (mAmps) |
| 0.47 | 6.3×11 | 529 | 12 | 6.3×11 | 529 | 12 | 6.3×11 | 529 | 12 | 6.3×11 | 705 | 11 | 6.3×11 | 705 | 11 | — | — | — | |
| 1 | 6.3×11 | 248 | 18 | 6.3×11 | 248 | 18 | 6.3×11 | 248 | 18 | 6.3×11 | 331 | 16 | 6.3×11 | 331 | 18 | 8×11.5 | 331 | 18 | |
| 2.2 | 6.3×11 | 113 | 26 | 6.3×11 | 113 | 26 | 8×11.5 | 113 | 30 | 8×11.5 | 150 | 27 | 8×11.5 | 150 | 30 | 10×12.5 | 150 | 30 | |
| 3.3 | 8×11.5 | 75.4 | 37 | 8×11.5 | 75.4 | 37 | 10×12.5 | 75.4 | 43 | 10×12.5 | 100 | 36 | 10×12.5 | 100 | 36 | 10×16 | 100 | 40 | |
| 4.7 | 8×11.5 | 52.9 | 44 | 10×12.5 | 52.9 | 50 | 10×12.5 | 52.9 | 50 | 10×16 | 70.6 | 47 | 10×16 | 70.6 | 47 | 10×20 | 70.6 | 52 | |
| 10 | 10×12.5 | 24.9 | 75 | 10×16 | 24.9 | 80 | 10×20 | 24.9 | 90 | 10×20 | 33.2 | 75 | 12.5×20 | 33.2 | 79 | 12.5×20 | 33.2 | 79 | |
| 22 | 10×20 | 11.3 | 135 | 10×20 | 11.3 | 135 | 12.5×25 | 11.3 | 155 | 12.5×25 | 15.1 | 130 | 12.5×25 | 15.1 | 130 | 16×25 | 15.1 | 130 | |
| 33 | 12.5×20 | 7.54 | 175 | 12.5×25 | 7.54 | 190 | 12.5×25 | 7.54 | 190 | 16×25 | 10.1 | 160 | 16×25 | 10.1 | 160 | 16×31.5 | 10.1 | 175 | |
| 47 | 12.5×25 | 5.29 | 230 | 12.5×25 | 5.29 | 230 | 16×25 | 5.29 | 225 | 16×31.5 | 7.06 | 210 | 16×31.5 | 7.06 | 210 | 18×35.5 | 7.06 | 220 | |
| 100 | 16×25 | 2.49 | 330 | 16×31.5 | 2.49 | 360 | 18×35.5 | 2.49 | 340 | 18×40 | 3.32 | 335 | 18×40 | 3.32 | 335 | — | — | — | |
| 220 | 18×35.5 | 1.13 | 500 | 18×40 | 1.13 | 525 | — | — | — | — | — | — | — | — | — | — | — | — | |

(Note) Rated ripple current : 105°C, 120Hz ; ESR. : 20°C, 120Hz

105°C Use, Miniature, High-Reliability, Low Impedance Capacitors

GREEN CAP

Low Impedance

105°C 5000hours

Anti-cleaning solvent

- Smaller and higher ripple current than RJB Series.
- Guarantees 5000 hours at 105°C.
(ϕ 5 to 6.3 : 2000 hours ; ϕ 8 to 10 : 3000 hours)

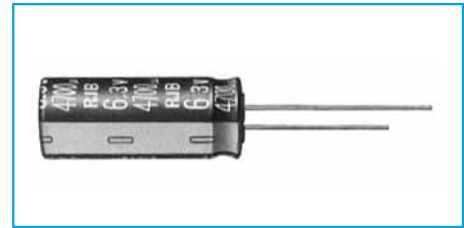

Marking color : White print on a black sleeve

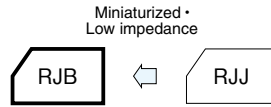

Specifications

| Item | Performance | | | | | | | | |
|--|--|--|------|------|------|------|------|------|------|
| Category temperature range (°C) | -55 to +105 | | | | | | | | |
| Tolerance at rated capacitance (%) | ±20 (20°C,120Hz) | | | | | | | | |
| Leakage current (µA) | Less than 0.01CV + 2 (after 2 minutes) C : Rated capacitance (µF) ; V : Rated voltage (V) (20°C) | | | | | | | | |
| Tangent of loss angle (tanδ) | Rated voltage (V) | 6.3 | 10 | 16 | 25 | 35 | 50 | 63 | 100 |
| | tanδ (max.) | 0.22 | 0.19 | 0.16 | 0.14 | 0.12 | 0.10 | 0.08 | 0.07 |
| 0.02 is added to every 1000µF increase over 1000µF. (20°C,120Hz) | | | | | | | | | |
| Characteristics at high and low temperature | Rated voltage (V) | 6.3 | 10 | 16 | 25 | 35 | 50 | 63 | 100 |
| | Impedance ratio (max.) | Z-55°C/Z+20°C | 3 | 3 | 3 | 3 | 3 | 3 | 3 |
| (120Hz) | | | | | | | | | |
| Endurance (105°C) (Applied ripple current) | Test time | 5000 hours (ϕ 5 to 6.3 : 2000 hours) (ϕ 8 to 10 : 3000 hours) | | | | | | | |
| | Leakage current | The initial specified value or less | | | | | | | |
| | Percentage of capacitance change | Within ±20% of initial value | | | | | | | |
| | Tangent of the loss angle | 200% or less of the initial specified value | | | | | | | |
| Shelf life (105°C) | Test time | 1000 hours | | | | | | | |
| | Leakage current | The initial specified value or less | | | | | | | |
| | Percentage of capacitance change | Within ±15% of initial value | | | | | | | |
| | Tangent of the loss angle | 150% or less of the initial specified value | | | | | | | |
| Voltage application treatment | | | | | | | | | |
| Applicable standards | JIS C5101-1, -4 1998 (IEC 60384-1 1992, -4 1985) | | | | | | | | |

Outline Drawing

Unit : mm

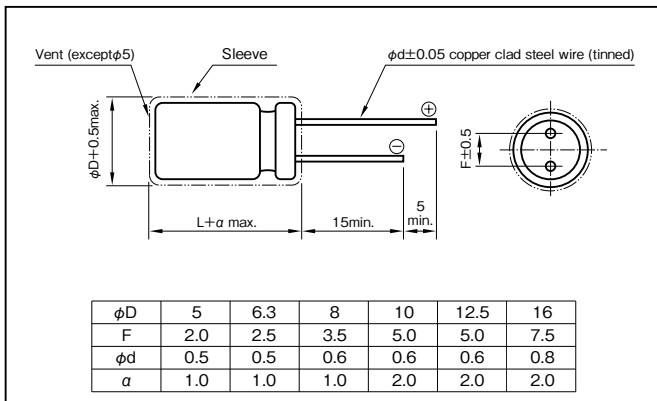

Coefficient of Frequency for Rated Ripple Current

| Rated capacitance (µF) | Frequency (Hz) | | | |
|------------------------|----------------|------|------|------|
| | 120 | 1k | 10k | 100k |
| 3.3 to 180 | 0.40 | 0.75 | 0.90 | 1 |
| 220 to 390 | 0.50 | 0.85 | 0.95 | 1 |
| 470 to 1800 | 0.60 | 0.88 | 0.96 | 1 |
| 2200 to 3900 | 0.75 | 0.90 | 0.98 | 1 |
| 4700 to 10000 | 0.85 | 0.95 | 1.00 | 1 |

Part numbering system (example : 10V1000µF)

| | | | | | | | | | |
|-------------|---|----------------------|---|--------------------------|------------------------------|---------------|---|---|------------------------|
| RJB | — | 10 | V | 102 | M | H4 | # | — | □ |
| Series code | | Rated voltage symbol | | Rated capacitance symbol | Capacitance tolerance symbol | Casing symbol | | | Taping(Forming) symbol |

• The electric characteristics are described on page 183.

Standard Ratings

| Rated voltage (V) | Item | 6.3 | | | | | 10 | | | | | 16 | | | | |
|-------------------|----------|-----------|---------------|--------------------|-------|------------------------------|------|---------------|--------------------|-------|------------------------------|------|---------------|--------------------|-------|------------------------------|
| | | Case | Casing symbol | Impedance (Ω max.) | | Rated ripple current (mAmps) | Case | Casing symbol | Impedance (Ω max.) | | Rated ripple current (mAmps) | Case | Casing symbol | Impedance (Ω max.) | | Rated ripple current (mAmps) |
| | | | | 20°C | -10°C | | | | 20°C | -10°C | | | | 20°C | -10°C | |
| | | φD×L (mm) | | | | φD×L (mm) | | | | | φD×L (mm) | | | | | |
| 100 | — | — | — | — | — | 5×11.5 | E3 | 0.65 | 1.3 | 181 | — | — | — | — | — | |
| 220 | — | — | — | — | — | 6.3×11.5 | F3 | 0.32 | 0.64 | 290 | — | — | — | — | — | |
| 330 | 6.3×11.5 | F3 | 0.32 | 0.64 | 290 | 8×12 | G3 | 0.17 | 0.34 | 555 | 8×12 | G3 | 0.17 | 0.34 | 555 | |
| 470 | 8×12 | G3 | 0.17 | 0.34 | 555 | 8×12 | G3 | 0.17 | 0.34 | 555 | 10×12.5 | H3 | 0.12 | 0.24 | 760 | |
| 680 | 8×12 | G3 | 0.17 | 0.34 | 555 | 10×12.5 | H3 | 0.12 | 0.24 | 760 | 10×16 | H4 | 0.080 | 0.16 | 1050 | |
| 1000 | 10×12.5 | H3 | 0.12 | 0.24 | 760 | 10×16 | H4 | 0.080 | 0.16 | 1050 | 10×20 | H5 | 0.062 | 0.124 | 1220 | |
| 2200 | 10×25 | H6 | 0.052 | 0.104 | 1440 | 12.5×20 | I5 | 0.042 | 0.084 | 1690 | 12.5×25 | I6 | 0.034 | 0.068 | 1950 | |
| 3300 | 12.5×20 | I5 | 0.042 | 0.084 | 1690 | 12.5×25 | I6 | 0.034 | 0.068 | 1950 | 16×25 | J6 | 0.028 | 0.056 | 2560 | |
| 4700 | 12.5×30 | I7 | 0.030 | 0.060 | 2310 | 16×25 | J6 | 0.028 | 0.056 | 2560 | 16×31.5 | J7 | 0.025 | 0.050 | 3010 | |
| 6800 | 16×25 | J6 | 0.028 | 0.056 | 2560 | 16×31.5 | J7 | 0.025 | 0.050 | 3010 | — | — | — | — | — | |
| 10000 | 16×31.5 | J7 | 0.025 | 0.050 | 3010 | — | — | — | — | — | — | — | — | — | — | |

| Rated voltage (V) | Item | 25 | | | | | 35 | | | | | 50 | | | | |
|-------------------|----------|-----------|---------------|--------------------|-------|------------------------------|------|---------------|--------------------|-------|------------------------------|------|---------------|--------------------|-------|------------------------------|
| | | Case | Casing symbol | Impedance (Ω max.) | | Rated ripple current (mAmps) | Case | Casing symbol | Impedance (Ω max.) | | Rated ripple current (mAmps) | Case | Casing symbol | Impedance (Ω max.) | | Rated ripple current (mAmps) |
| | | | | 20°C | -10°C | | | | 20°C | -10°C | | | | 20°C | -10°C | |
| | | φD×L (mm) | | | | φD×L (mm) | | | | | φD×L (mm) | | | | | |
| 22 | — | — | — | — | — | — | — | — | — | — | 5×11.5 | E3 | 0.95 | 1.9 | 170 | |
| 33 | — | — | — | — | — | 5×11.5 | E3 | 0.65 | 1.3 | 181 | 6.3×11.5 | F3 | 0.46 | 0.92 | 260 | |
| 47 | 5×11.5 | E3 | 0.65 | 1.3 | 181 | 6.3×11.5 | F3 | 0.32 | 0.64 | 290 | 6.3×11.5 | F3 | 0.46 | 0.92 | 260 | |
| 100 | 6.3×11.5 | F3 | 0.32 | 0.64 | 290 | 8×12 | G3 | 0.17 | 0.34 | 555 | 8×12 | G3 | 0.21 | 0.42 | 485 | |
| 150 | — | — | — | — | — | — | — | — | — | — | 10×12.5 | H3 | 0.19 | 0.38 | 615 | |
| 220 | 8×12 | G3 | 0.17 | 0.34 | 555 | 10×12.5 | H3 | 0.12 | 0.24 | 760 | 10×16 | H4 | 0.16 | 0.32 | 850 | |
| 330 | 10×12.5 | H3 | 0.12 | 0.24 | 760 | 10×16 | H4 | 0.080 | 0.16 | 1050 | 10×20 | H5 | 0.085 | 0.17 | 1050 | |
| 470 | 10×16 | H4 | 0.080 | 0.16 | 1050 | 10×20 | H5 | 0.062 | 0.124 | 1220 | 12.5×20 | I5 | 0.060 | 0.12 | 1500 | |
| 680 | 10×20 | H5 | 0.062 | 0.124 | 1220 | 12.5×20 | I5 | 0.042 | 0.084 | 1690 | 12.5×25 | I6 | 0.045 | 0.090 | 1832 | |
| 1000 | 12.5×20 | I5 | 0.042 | 0.084 | 1690 | 12.5×25 | I6 | 0.034 | 0.068 | 1950 | 16×25 | J6 | 0.038 | 0.076 | 2240 | |
| 2200 | 16×25 | J6 | 0.028 | 0.056 | 2560 | 16×31.5 | J7 | 0.025 | 0.050 | 3010 | — | — | — | — | — | |
| 3300 | 16×31.5 | J7 | 0.025 | 0.050 | 3010 | — | — | — | — | — | — | — | — | — | — | |

| Rated voltage (V) | Item | 63 | | | | | 100 | | | | |
|-------------------|----------|-----------|---------------|--------------------|-------|------------------------------|------|---------------|--------------------|-------|------------------------------|
| | | Case | Casing symbol | Impedance (Ω max.) | | Rated ripple current (mAmps) | Case | Casing symbol | Impedance (Ω max.) | | Rated ripple current (mAmps) |
| | | | | 20°C | -10°C | | | | 20°C | -10°C | |
| | | φD×L (mm) | | | | φD×L (mm) | | | | | |
| 3.3 | — | — | — | — | — | 5×11.5 | E3 | 1.9 | 7.6 | 57 | |
| 4.7 | 5×11.5 | E3 | 1.2 | 3.6 | 120 | 5×11.5 | E3 | 1.9 | 7.6 | 57 | |
| 10 | 5×11.5 | E3 | 1.2 | 3.6 | 120 | 6.3×11.5 | F3 | 1.1 | 4.4 | 78 | |
| 22 | 6.3×11.5 | F3 | 0.55 | 1.7 | 148 | 8×12 | G3 | 0.53 | 2.1 | 275 | |
| 33 | 6.3×11.5 | F3 | 0.55 | 1.7 | 148 | 10×12.5 | H3 | 0.47 | 1.9 | 319 | |
| 47 | 8×12 | G3 | 0.32 | 0.96 | 360 | 10×16 | H4 | 0.32 | 1.3 | 424 | |
| 100 | 10×12.5 | H3 | 0.23 | 0.69 | 448 | 12.5×20 | I5 | 0.13 | 0.52 | 805 | |
| 220 | 10×20 | H5 | 0.12 | 0.36 | 676 | 16×25 | J6 | 0.081 | 0.32 | 1290 | |
| 330 | 12.5×20 | I5 | 0.075 | 0.23 | 979 | 16×25 | J6 | 0.081 | 0.32 | 1290 | |
| 470 | 12.5×25 | I6 | 0.065 | 0.20 | 1180 | 16×31.5 | J7 | 0.059 | 0.23 | 1630 | |
| 1000 | 16×31.5 | J7 | 0.042 | 0.13 | 1890 | — | — | — | — | — | |

(Note) Rated ripple current : 105°C, 100kHz ; Impedance : 100kHz

105°C Use, High-Reliability, Low Impedance Capacitors

GREEN CAP Low Impedance 105°C 5000hours Anti-cleaning solvent

- The capacitor of this Series achieves high reliability under the environmental loading prevailing in a piece of equipment on which it is mounted.
- Guarantees 5000 hours at 105°C.
($\phi 5$ to 6.3 : 2000 hours ; $\phi 8$ to 10 : 3000 hours)

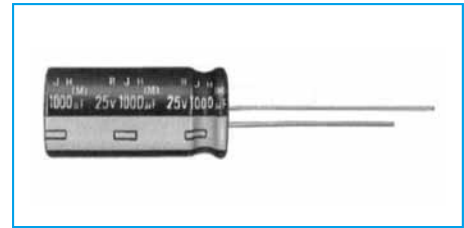
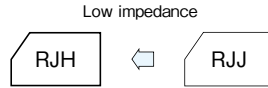

Marking color : White print on a black sleeve

Specifications

| Item | Performance | | | | | | | | | | | | | | | | | | | | | | | | | | |
|---|---|--|------|------|------|------|------|------|-----|-----|------------------------|---------------|------|------|------|------|------|------|------|---------------|---|---|---|---|---|---|---|
| Category temperature range (°C) | -55 to +105 | | | | | | | | | | | | | | | | | | | | | | | | | | |
| Tolerance at rated capacitance (%) | ±20 (20°C, 120Hz) | | | | | | | | | | | | | | | | | | | | | | | | | | |
| Leakage current (µA) | Less than 0.01CV + 2 (after 2 minutes) C : Rated capacitance (µF) ; V : Rated voltage (V) (20°C) | | | | | | | | | | | | | | | | | | | | | | | | | | |
| Tangent of loss angle (tanδ) | <table border="1"> <tr> <th>Rated voltage (V)</th> <th>6.3</th> <th>10</th> <th>16</th> <th>25</th> <th>35</th> <th>50</th> <th>63</th> <th>100</th> </tr> <tr> <th>tanδ (max.)</th> <td>0.22</td> <td>0.19</td> <td>0.16</td> <td>0.14</td> <td>0.12</td> <td>0.10</td> <td>0.08</td> <td>0.07</td> </tr> </table> | Rated voltage (V) | 6.3 | 10 | 16 | 25 | 35 | 50 | 63 | 100 | tanδ (max.) | 0.22 | 0.19 | 0.16 | 0.14 | 0.12 | 0.10 | 0.08 | 0.07 | | | | | | | | |
| | Rated voltage (V) | 6.3 | 10 | 16 | 25 | 35 | 50 | 63 | 100 | | | | | | | | | | | | | | | | | | |
| tanδ (max.) | 0.22 | 0.19 | 0.16 | 0.14 | 0.12 | 0.10 | 0.08 | 0.07 | | | | | | | | | | | | | | | | | | | |
| 0.02 is added to every 1000µF increase over 1000µF. (20°C, 120Hz) | | | | | | | | | | | | | | | | | | | | | | | | | | | |
| Characteristics at high and low temperature | <table border="1"> <tr> <th>Rated voltage (V)</th> <th>6.3</th> <th>10</th> <th>16</th> <th>25</th> <th>35</th> <th>50</th> <th>63</th> <th>100</th> </tr> <tr> <th rowspan="2">Impedance ratio (max.)</th> <td>Z-25°C/Z+20°C</td> <td>2</td> <td>2</td> <td>2</td> <td>2</td> <td>2</td> <td>2</td> <td>2</td> </tr> <tr> <td>Z-55°C/Z+20°C</td> <td>3</td> <td>3</td> <td>3</td> <td>3</td> <td>3</td> <td>3</td> <td>3</td> </tr> </table> | Rated voltage (V) | 6.3 | 10 | 16 | 25 | 35 | 50 | 63 | 100 | Impedance ratio (max.) | Z-25°C/Z+20°C | 2 | 2 | 2 | 2 | 2 | 2 | 2 | Z-55°C/Z+20°C | 3 | 3 | 3 | 3 | 3 | 3 | 3 |
| | Rated voltage (V) | 6.3 | 10 | 16 | 25 | 35 | 50 | 63 | 100 | | | | | | | | | | | | | | | | | | |
| Impedance ratio (max.) | Z-25°C/Z+20°C | 2 | 2 | 2 | 2 | 2 | 2 | 2 | | | | | | | | | | | | | | | | | | | |
| | Z-55°C/Z+20°C | 3 | 3 | 3 | 3 | 3 | 3 | 3 | | | | | | | | | | | | | | | | | | | |
| (120Hz) | | | | | | | | | | | | | | | | | | | | | | | | | | | |
| Endurance (105°C) (Applied ripple current) | Test time | 5000 hours ($\phi 5$ to 6.3 : 2000 hours) ($\phi 8$ to 10 : 3000 hours) | | | | | | | | | | | | | | | | | | | | | | | | | |
| | Leakage current | The initial specified value or less | | | | | | | | | | | | | | | | | | | | | | | | | |
| | Percentage of capacitance change | Within ±20% of initial value | | | | | | | | | | | | | | | | | | | | | | | | | |
| | Tangent of the loss angle | 200% or less of the initial specified value | | | | | | | | | | | | | | | | | | | | | | | | | |
| Shelf life (105°C) | Test time | 1000 hours | | | | | | | | | | | | | | | | | | | | | | | | | |
| | Leakage current | The initial specified value or less | | | | | | | | | | | | | | | | | | | | | | | | | |
| | Percentage of capacitance change | Within ±15% of initial value | | | | | | | | | | | | | | | | | | | | | | | | | |
| | Tangent of the loss angle | 150% or less of the initial specified value | | | | | | | | | | | | | | | | | | | | | | | | | |
| Voltage application treatment | | | | | | | | | | | | | | | | | | | | | | | | | | | |
| Applicable standards | JIS C5101-1, -4 1998 (IEC 60384-1 1992, -4 1985) | | | | | | | | | | | | | | | | | | | | | | | | | | |

Outline Drawing

Unit : mm

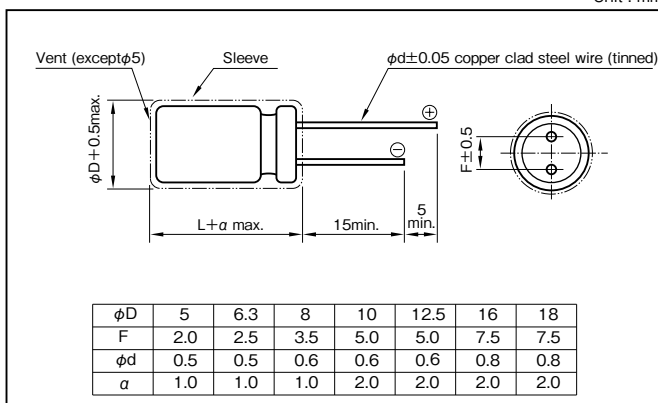

Coefficient of Frequency for Rated Ripple Current

| Rated capacitance (µF) | Frequency (Hz) | | | |
|------------------------|----------------|------|------|------|
| | 120 | 1k | 10k | 100k |
| 1 to 4.7 | 0.40 | 0.68 | 0.78 | 1 |
| 5.6 to 47 | 0.50 | 0.76 | 0.87 | 1 |
| 56 to 270 | 0.70 | 0.85 | 0.90 | 1 |
| 330 to 1000 | 0.80 | 0.93 | 0.98 | 1 |
| 1200 to 15000 | 0.90 | 0.95 | 1.00 | 1 |

Part numbering system (example : 10V5600µF)

| | | | | | | | | | |
|-------------|---|----------------------|---|--------------------------|------------------------------|---------------|---|---|-----------------------|
| RJH | — | 10 | V | 562 | M | J7 | # | — | □ |
| Series code | | Rated voltage symbol | | Rated capacitance symbol | Capacitance tolerance symbol | Casing symbol | | | Taping/Forming symbol |

Standard Ratings

| Rated voltage (V) | | 6.3 | | | | | 10 | | | | | |
|-------------------|------------------|------|---------------------------|------------|--------------------|-------|---------------------------------|---------------------------|------------|--------------------|-------|---------------------------------|
| Case φD×L (mm) | Casing symbol | Item | Rated capacitance (μF) | ESR (Ω) | Impedance (Ω max.) | | Rated ripple current (mArms) | Rated capacitance (μF) | ESR (Ω) | Impedance (Ω max.) | | Rated ripple current (mArms) |
| | | | | | 20°C | -10°C | | | | 20°C | -10°C | |
| 5×11.5 | E3 | | 100 | 3.65 | 0.65 | 1.46 | 175 | 82 | 3.84 | 0.65 | 1.46 | 175 |
| 6.3×11.5 | F3 | | 220 | 1.66 | 0.31 | 0.70 | 290 | 180 | 1.75 | 0.31 | 0.70 | 290 |
| 8×12 | G3 | | 470 | 0.777 | 0.17 | 0.38 | 488 | 330 | 0.956 | 0.17 | 0.38 | 488 |
| 8×15 | G4 | | 680 | 0.537 | 0.13 | 0.29 | 617 | 470 | 0.671 | 0.13 | 0.29 | 617 |
| 8×20 | G5 | | 1000 | 0.365 | 0.095 | 0.21 | 800 | 680 | 0.464 | 0.095 | 0.21 | 800 |
| 10×12.5 | H3 | | 680 | 0.537 | 0.10 | 0.23 | 625 | 470 | 0.671 | 0.10 | 0.23 | 625 |
| 10×16 | H4 | | 820 | 0.446 | 0.080 | 0.18 | 825 | 560 | 0.563 | 0.080 | 0.18 | 825 |
| 10×20 | H5 | | 1200 | 0.305 | 0.062 | 0.14 | 1010 | 1000 | 0.316 | 0.062 | 0.14 | 1010 |
| 10×25 | H6 | | 1500 | 0.244 | 0.052 | 0.12 | 1190 | 1200 | 0.263 | 0.052 | 0.12 | 1190 |
| 10×30 | H7 | | 2200 | 0.181 | 0.044 | 0.099 | 1440 | 1500 | 0.211 | 0.044 | 0.099 | 1440 |
| 12.5×15 | I4 | • | 1200 | 0.305 | 0.062 | 0.14 | 1010 | • 1000 | 0.316 | 0.062 | 0.14 | 1010 |
| 12.5×20 | I5 | | 2200 | 0.181 | 0.042 | 0.095 | 1400 | 1800 | 0.176 | 0.042 | 0.095 | 1400 |
| 12.5×25 | I6 | | 2700 | 0.148 | 0.034 | 0.076 | 1690 | 2200 | 0.159 | 0.034 | 0.076 | 1690 |
| 12.5×30 | I7 | | 3900 | 0.111 | 0.030 | 0.068 | 1950 | 2700 | 0.130 | 0.030 | 0.068 | 1950 |
| 12.5×35 | I8 | | 4700 | 0.099 | 0.024 | 0.054 | 2220 | 3300 | 0.116 | 0.024 | 0.054 | 2220 |
| 12.5×40 | I9 | | 5600 | 0.089 | 0.021 | 0.047 | 2390 | 3900 | 0.098 | 0.021 | 0.047 | 2390 |
| 16×16 | J4 | • | 2700 | 0.148 | 0.046 | 0.10 | 1310 | • 1800 | 0.176 | 0.046 | 0.10 | 1310 |
| 16×20 | J5 | • | 4700 | 0.099 | 0.034 | 0.077 | 1660 | • 3300 | 0.116 | 0.034 | 0.077 | 1660 |
| 16×25 | J6 | | 5600 | 0.089 | 0.028 | 0.063 | 2070 | 3900 | 0.098 | 0.028 | 0.063 | 2070 |
| 16×31.5 | J7 | | 6800 | 0.079 | 0.025 | 0.056 | 2350 | 5600 | 0.080 | 0.025 | 0.056 | 2350 |
| 16×35.5 | J8 | | 8200 | 0.073 | 0.022 | 0.050 | 2550 | 6800 | 0.071 | 0.022 | 0.050 | 2550 |
| 16×40 | J9 | | 12000 | 0.059 | 0.018 | 0.041 | 2970 | 8200 | 0.067 | 0.018 | 0.041 | 2970 |
| 18×16 | K4 | • | 3300 | 0.131 | 0.043 | 0.097 | 1460 | • 2200 | 0.159 | 0.043 | 0.097 | 1460 |
| 18×20 | K5 | • | 5600 | 0.089 | 0.030 | 0.068 | 1850 | • 3900 | 0.098 | 0.030 | 0.068 | 1850 |
| 18×25 | K6 | • | 6800 | 0.079 | 0.027 | 0.061 | 2120 | • 4700 | 0.089 | 0.027 | 0.061 | 2120 |
| 18×31.5 | K7 | | 10000 | 0.064 | 0.023 | 0.052 | 2410 | 6800 | 0.071 | 0.023 | 0.052 | 2410 |
| 18×35.5 | K8 | | 12000 | 0.059 | 0.019 | 0.043 | 2680 | 8200 | 0.067 | 0.019 | 0.043 | 2680 |
| 18×40 | K9 | | 15000 | 0.054 | 0.017 | 0.038 | 3010 | 10000 | 0.059 | 0.017 | 0.038 | 3010 |

MINIATURE ALUMINUM

| Rated voltage (V) | | 16 | | | | | 25 | | | | | |
|-------------------|------------------|------|---------------------------|------------|--------------------|-------|---------------------------------|---------------------------|------------|--------------------|-------|---------------------------------|
| Case φD×L (mm) | Casing symbol | Item | Rated capacitance (μF) | ESR (Ω) | Impedance (Ω max.) | | Rated ripple current (mArms) | Rated capacitance (μF) | ESR (Ω) | Impedance (Ω max.) | | Rated ripple current (mArms) |
| | | | | | 20°C | -10°C | | | | 20°C | -10°C | |
| 5×11.5 | E3 | | 56 | 4.74 | 0.65 | 1.46 | 175 | 39 | 5.96 | 0.65 | 1.46 | 175 |
| 6.3×11.5 | F3 | | 120 | 2.21 | 0.31 | 0.70 | 290 | 82 | 2.83 | 0.31 | 0.70 | 290 |
| 8×12 | G3 | | 270 | 0.983 | 0.17 | 0.38 | 488 | 180 | 1.29 | 0.17 | 0.38 | 488 |
| 8×15 | G4 | | 330 | 0.805 | 0.13 | 0.29 | 617 | 220 | 1.06 | 0.13 | 0.29 | 617 |
| 8×20 | G5 | | 470 | 0.565 | 0.095 | 0.21 | 800 | 330 | 0.704 | 0.095 | 0.21 | 800 |
| 10×12.5 | H3 | | 330 | 0.805 | 0.10 | 0.23 | 625 | 220 | 1.06 | 0.10 | 0.23 | 625 |
| 10×16 | H4 | | 390 | 0.681 | 0.080 | 0.18 | 825 | 270 | 0.861 | 0.080 | 0.18 | 825 |
| 10×20 | H5 | | 680 | 0.391 | 0.062 | 0.14 | 1010 | 470 | 0.495 | 0.062 | 0.14 | 1010 |
| 10×25 | H6 | | 820 | 0.324 | 0.052 | 0.12 | 1190 | 560 | 0.415 | 0.052 | 0.12 | 1190 |
| 10×30 | H7 | | 1200 | 0.222 | 0.044 | 0.099 | 1440 | 820 | 0.284 | 0.044 | 0.099 | 1440 |
| 12.5×15 | I4 | • | 680 | 0.391 | 0.062 | 0.14 | 1010 | • 470 | 0.495 | 0.062 | 0.14 | 1010 |
| 12.5×20 | I5 | | 1200 | 0.222 | 0.042 | 0.095 | 1400 | 820 | 0.284 | 0.042 | 0.095 | 1400 |
| 12.5×25 | I6 | | 1500 | 0.177 | 0.034 | 0.076 | 1690 | 1000 | 0.233 | 0.034 | 0.076 | 1690 |
| 12.5×30 | I7 | | 2200 | 0.136 | 0.030 | 0.068 | 1950 | 1500 | 0.155 | 0.030 | 0.068 | 1950 |
| 12.5×35 | I8 | | 2700 | 0.111 | 0.024 | 0.054 | 2220 | 1800 | 0.130 | 0.024 | 0.054 | 2220 |
| 12.5×40 | I9 | | 3300 | 0.101 | 0.021 | 0.047 | 2390 | 2200 | 0.121 | 0.021 | 0.047 | 2390 |
| 16×16 | J4 | • | 1500 | 0.177 | 0.046 | 0.10 | 1310 | • 820 | 0.284 | 0.046 | 0.10 | 1310 |
| 16×20 | J5 | • | 2200 | 0.136 | 0.034 | 0.077 | 1660 | • 1500 | 0.155 | 0.034 | 0.077 | 1660 |
| 16×25 | J6 | | 2700 | 0.111 | 0.028 | 0.063 | 2070 | 1800 | 0.130 | 0.028 | 0.063 | 2070 |
| 16×31.5 | J7 | | 3900 | 0.086 | 0.025 | 0.056 | 2350 | 2700 | 0.099 | 0.025 | 0.056 | 2350 |
| 16×35.5 | J8 | | 4700 | 0.078 | 0.022 | 0.050 | 2550 | 3300 | 0.091 | 0.022 | 0.050 | 2550 |
| 16×40 | J9 | | 5600 | 0.072 | 0.018 | 0.041 | 2970 | 3900 | 0.077 | 0.018 | 0.041 | 2970 |
| 18×16 | K4 | • | 1500 | 0.177 | 0.043 | 0.097 | 1460 | • 1200 | 0.194 | 0.043 | 0.097 | 1460 |
| 18×20 | K5 | • | 2700 | 0.111 | 0.030 | 0.068 | 1850 | • 1800 | 0.130 | 0.030 | 0.068 | 1850 |
| 18×25 | K6 | • | 3900 | 0.086 | 0.027 | 0.061 | 2120 | • 2700 | 0.099 | 0.027 | 0.061 | 2120 |
| 18×31.5 | K7 | | 4700 | 0.078 | 0.023 | 0.052 | 2410 | 3300 | 0.091 | 0.023 | 0.052 | 2410 |
| 18×35.5 | K8 | | 6800 | 0.064 | 0.019 | 0.043 | 2680 | 3900 | 0.077 | 0.019 | 0.043 | 2680 |
| 18×40 | K9 | | 8200 | 0.061 | 0.017 | 0.038 | 3010 | 4700 | 0.071 | 0.017 | 0.038 | 3010 |

(Note) Rated ripple current : 105°C, 100kHz; ESR : 20°C, 120Hz; Impedance : 100kHz
 • : The black circles in the capacitance column denote semi-standard products.

• The standard ratings follow the next page.

NOTE : Design, Specifications are subject to change without notice.
 It is recommended that you shall obtain technical specifications from ELNA to ensure that the component is suitable for your use.

Standard Ratings

| Rated voltage (V) | | | 35 | | | | | 50 | | | | |
|-------------------|------------------|------|---------------------------|------------|--------------------|-------|---------------------------------|---------------------------|------------|--------------------|-------|---------------------------------|
| Case φD×L (mm) | Casing symbol | Item | Rated capacitance (μF) | ESR (Ω) | Impedance (Ω max.) | | Rated ripple current (mArms) | Rated capacitance (μF) | ESR (Ω) | Impedance (Ω max.) | | Rated ripple current (mArms) |
| | | | | | 20°C | -10°C | | | | 20°C | -10°C | |
| 5×11.5 | E3 | | — | — | — | — | — | 1 | 166 | 3.5 | 7.0 | 36 |
| 5×11.5 | E3 | | — | — | — | — | — | 2.2 | 75.4 | 3.0 | 6.0 | 54 |
| 5×11.5 | E3 | | — | — | — | — | — | 3.3 | 50.3 | 2.6 | 5.2 | 63 |
| 5×11.5 | E3 | | — | — | — | — | — | 4.7 | 35.3 | 2.2 | 4.4 | 75 |
| 5×11.5 | E3 | | — | — | — | — | — | 10 | 16.6 | 1.4 | 2.8 | 110 |
| 5×11.5 | E3 | | 27 | 7.37 | 0.65 | 1.46 | 175 | 18 | 9.22 | 0.95 | 1.9 | 120 |
| 6.3×11.5 | F3 | | 56 | 3.56 | 0.31 | 0.70 | 290 | 39 | 4.25 | 0.43 | 0.86 | 148 |
| 8×12 | G3 | | 120 | 1.66 | 0.17 | 0.38 | 488 | 68 | 2.44 | 0.20 | 0.40 | 360 |
| 8×15 | G4 | | 180 | 1.11 | 0.13 | 0.29 | 617 | 82 | 2.02 | 0.18 | 0.36 | 460 |
| 8×20 | G5 | | 220 | 0.905 | 0.095 | 0.21 | 800 | 120 | 1.38 | 0.13 | 0.26 | 670 |
| 10×12.5 | H3 | | 150 | 1.33 | 0.10 | 0.23 | 625 | 82 | 2.02 | 0.18 | 0.36 | 443 |
| 10×16 | H4 | | 180 | 1.11 | 0.080 | 0.18 | 825 | 100 | 1.66 | 0.15 | 0.30 | 553 |
| 10×20 | H5 | | 330 | 0.604 | 0.062 | 0.14 | 1010 | 180 | 0.922 | 0.085 | 0.17 | 676 |
| 10×25 | H6 | | 390 | 0.511 | 0.052 | 0.12 | 1190 | 220 | 0.754 | 0.075 | 0.15 | 876 |
| 10×30 | H7 | | 560 | 0.356 | 0.044 | 0.099 | 1440 | 330 | 0.503 | 0.055 | 0.11 | 1010 |
| 12.5×15 | I4 | • | 330 | 0.604 | 0.062 | 0.140 | 1010 | • 180 | 0.922 | 0.095 | 0.19 | 745 |
| 12.5×20 | I5 | | 560 | 0.356 | 0.042 | 0.095 | 1400 | 330 | 0.503 | 0.060 | 0.12 | 979 |
| 12.5×25 | I6 | | 680 | 0.293 | 0.034 | 0.076 | 1690 | 470 | 0.353 | 0.044 | 0.088 | 1180 |
| 12.5×30 | I7 | | 1000 | 0.200 | 0.030 | 0.068 | 1950 | 560 | 0.297 | 0.040 | 0.080 | 1310 |
| 12.5×35 | I8 | | 1200 | 0.166 | 0.024 | 0.054 | 2220 | 680 | 0.244 | 0.036 | 0.072 | 1470 |
| 12.5×40 | I9 | | 1500 | 0.133 | 0.021 | 0.047 | 2390 | 820 | 0.203 | 0.034 | 0.068 | 1590 |
| 16×16 | J4 | • | 560 | 0.356 | 0.046 | 0.10 | 1310 | • 330 | 0.503 | 0.065 | 0.13 | 982 |
| 16×20 | J5 | • | 1000 | 0.200 | 0.034 | 0.077 | 1660 | • 680 | 0.244 | 0.045 | 0.090 | 1210 |
| 16×25 | J6 | | 1200 | 0.166 | 0.028 | 0.063 | 2070 | 820 | 0.203 | 0.038 | 0.076 | 1490 |
| 16×31.5 | J7 | | 1800 | 0.111 | 0.025 | 0.056 | 2350 | 1000 | 0.166 | 0.032 | 0.064 | 1890 |
| 16×35.5 | J8 | | 2200 | 0.106 | 0.022 | 0.050 | 2550 | 1200 | 0.139 | 0.028 | 0.056 | 2140 |
| 16×40 | J9 | | 2700 | 0.087 | 0.018 | 0.041 | 2970 | 1500 | 0.111 | 0.026 | 0.052 | 2410 |
| 18×16 | K4 | • | 680 | 0.293 | 0.043 | 0.097 | 1460 | • 470 | 0.353 | 0.048 | 0.096 | 1180 |
| 18×20 | K5 | • | 1200 | 0.166 | 0.030 | 0.068 | 1850 | • 820 | 0.203 | 0.036 | 0.072 | 1450 |
| 18×25 | K6 | • | 1800 | 0.111 | 0.027 | 0.061 | 2120 | • 1000 | 0.166 | 0.032 | 0.064 | 1720 |
| 18×31.5 | K7 | | 2200 | 0.106 | 0.023 | 0.052 | 2410 | 1500 | 0.111 | 0.026 | 0.052 | 1970 |
| 18×35.5 | K8 | | 2700 | 0.087 | 0.019 | 0.043 | 2680 | 1800 | 0.074 | 0.025 | 0.050 | 2310 |
| 18×40 | K9 | | 3300 | 0.081 | 0.017 | 0.038 | 3010 | 2200 | 0.073 | 0.024 | 0.048 | 2530 |

| Rated voltage (V) | | | 63 | | | | | 100 | | | | |
|-------------------|------------------|------|---------------------------|------------|--------------------|-------|---------------------------------|---------------------------|------------|--------------------|-------|---------------------------------|
| Case φD×L (mm) | Casing symbol | Item | Rated capacitance (μF) | ESR (Ω) | Impedance (Ω max.) | | Rated ripple current (mArms) | Rated capacitance (μF) | ESR (Ω) | Impedance (Ω max.) | | Rated ripple current (mArms) |
| | | | | | 20°C | -10°C | | | | 20°C | -10°C | |
| 5×11.5 | E3 | | 12 | 11.1 | 1.2 | 3.6 | 120 | 5.6 | 20.7 | 1.9 | 7.6 | 57 |
| 6.3×11.5 | F3 | | 27 | 4.92 | 0.55 | 1.7 | 148 | 12 | 9.68 | 1.1 | 4.4 | 78 |
| 8×12 | G3 | | 47 | 2.82 | 0.32 | 0.96 | 360 | 22 | 5.28 | 0.53 | 2.1 | 275 |
| 8×15 | G4 | | 68 | 1.95 | 0.24 | 0.72 | 469 | 33 | 3.52 | 0.35 | 1.4 | 360 |
| 8×20 | G5 | | 82 | 1.62 | 0.17 | 0.51 | 682 | 39 | 2.98 | 0.27 | 1.1 | 490 |
| 10×12.5 | H3 | | 56 | 2.37 | 0.23 | 0.69 | 448 | 27 | 4.30 | 0.47 | 1.9 | 319 |
| 10×16 | H4 | | 68 | 1.95 | 0.17 | 0.51 | 553 | 33 | 3.52 | 0.32 | 1.3 | 424 |
| 10×20 | H5 | | 120 | 1.11 | 0.12 | 0.36 | 676 | 56 | 2.07 | 0.25 | 1.0 | 499 |
| 10×25 | H6 | | 150 | 0.885 | 0.10 | 0.30 | 876 | 68 | 1.71 | 0.18 | 0.72 | 634 |
| 10×30 | H7 | | 180 | 0.738 | 0.085 | 0.26 | 1020 | 100 | 1.16 | 0.15 | 0.60 | 739 |
| 12.5×15 | I4 | • | 150 | 0.885 | 0.11 | 0.33 | 745 | • 68 | 1.71 | 0.20 | 0.80 | 613 |
| 12.5×20 | I5 | | 220 | 0.604 | 0.075 | 0.23 | 979 | 100 | 1.16 | 0.13 | 0.52 | 805 |
| 12.5×25 | I6 | | 270 | 0.492 | 0.065 | 0.20 | 1180 | 120 | 0.968 | 0.11 | 0.44 | 857 |
| 12.5×30 | I7 | | 390 | 0.341 | 0.055 | 0.17 | 1310 | 180 | 0.646 | 0.090 | 0.36 | 1120 |
| 12.5×35 | I8 | | 470 | 0.283 | 0.048 | 0.14 | 1470 | 220 | 0.528 | 0.075 | 0.30 | 1240 |
| 12.5×40 | I9 | | 560 | 0.237 | 0.042 | 0.13 | 1590 | 270 | 0.431 | 0.060 | 0.24 | 1330 |
| 16×16 | J4 | • | 220 | 0.604 | 0.080 | 0.24 | 982 | • 120 | 0.968 | 0.13 | 0.52 | 706 |
| 16×20 | J5 | • | 390 | 0.341 | 0.057 | 0.17 | 1210 | • 180 | 0.646 | 0.11 | 0.44 | 916 |
| 16×25 | J6 | | 470 | 0.283 | 0.052 | 0.16 | 1490 | 220 | 0.528 | 0.081 | 0.32 | 1290 |
| 16×31.5 | J7 | | 680 | 0.196 | 0.042 | 0.13 | 1890 | 330 | 0.352 | 0.059 | 0.23 | 1630 |
| 16×35.5 | J8 | | 820 | 0.162 | 0.036 | 0.11 | 2140 | 390 | 0.298 | 0.052 | 0.21 | 1750 |
| 16×40 | J9 | | 1000 | 0.133 | 0.032 | 0.096 | 2410 | 470 | 0.248 | 0.045 | 0.18 | 1920 |
| 18×16 | K4 | • | 330 | 0.403 | 0.065 | 0.20 | 1200 | • 150 | 0.775 | 0.12 | 0.48 | 871 |
| 18×20 | K5 | • | 560 | 0.237 | 0.058 | 0.17 | 1460 | • 270 | 0.431 | 0.085 | 0.34 | 1170 |
| 18×25 | K6 | • | 680 | 0.196 | 0.050 | 0.15 | 1740 | • 330 | 0.352 | 0.071 | 0.28 | 1500 |
| 18×31.5 | K7 | | 820 | 0.162 | 0.042 | 0.13 | 1990 | 390 | 0.298 | 0.058 | 0.23 | 1630 |
| 18×35.5 | K8 | | 1000 | 0.133 | 0.035 | 0.11 | 2340 | 560 | 0.208 | 0.054 | 0.22 | 1920 |
| 18×40 | K9 | | 1200 | 0.111 | 0.032 | 0.096 | 2560 | 680 | 0.171 | 0.041 | 0.16 | 2100 |

(Note) Rated ripple current : 105°C, 100kHz ; ESR : 20°C, 120Hz ; Impedance : 100kHz
 • : The black circles in the capacitance column denote semi-standard products.

105°C Use, Miniature, High-Reliability, Extra Low Impedance Capacitors

GREEN CAP Low Impedance 105°C 5000hours Anti-cleaning solvent

- Higher ripple current and Lower impedance than RJB series.

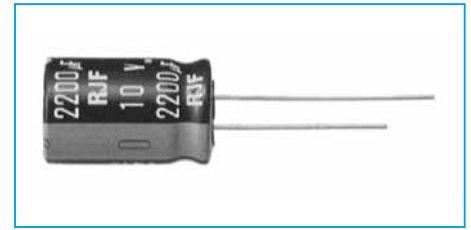
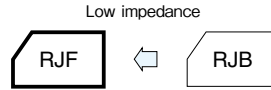

Marking color : White print on a black sleeve

Specifications

| Item | Performance | | | | | | | | | | | | | | | | | | | | | | | | | | | | | |
|---|---|-------------------|--|-----------------|-------------------------------------|----------------------------------|------------------------------|---------------------------|---|----|-----|------------------------|---------------|------|------|------|------|------|------|------|------|---------------|---|---|---|---|---|---|---|---|
| Category temperature range (°C) | -40 to +105 | | | | | | | | | | | | | | | | | | | | | | | | | | | | | |
| Tolerance at rated capacitance (%) | ±20 (20°C,120Hz) | | | | | | | | | | | | | | | | | | | | | | | | | | | | | |
| Leakage current (µA) | Less than 0.01CV or 3 whichever is larger (after 2 minutes) C : Rated capacitance (µF) ; V : Rated voltage (V) (20°C) | | | | | | | | | | | | | | | | | | | | | | | | | | | | | |
| Tangent of loss angle (tanδ) | <table border="1"> <tr> <td>Rated voltage (V)</td> <td>6.3</td> <td>10</td> <td>16</td> <td>25</td> <td>35</td> <td>50</td> <td>63</td> <td>80</td> <td>100</td> </tr> <tr> <td>tanδ (max.)</td> <td>0.22</td> <td>0.19</td> <td>0.16</td> <td>0.14</td> <td>0.12</td> <td>0.10</td> <td>0.09</td> <td>0.09</td> <td>0.08</td> </tr> </table> <p>0.02 is added to every 1000µF increase over 1000µF. (20°C,120Hz)</p> | Rated voltage (V) | 6.3 | 10 | 16 | 25 | 35 | 50 | 63 | 80 | 100 | tanδ (max.) | 0.22 | 0.19 | 0.16 | 0.14 | 0.12 | 0.10 | 0.09 | 0.09 | 0.08 | | | | | | | | | |
| Rated voltage (V) | 6.3 | 10 | 16 | 25 | 35 | 50 | 63 | 80 | 100 | | | | | | | | | | | | | | | | | | | | | |
| tanδ (max.) | 0.22 | 0.19 | 0.16 | 0.14 | 0.12 | 0.10 | 0.09 | 0.09 | 0.08 | | | | | | | | | | | | | | | | | | | | | |
| Characteristics at high and low temperature | <table border="1"> <tr> <td>Rated voltage (V)</td> <td>6.3</td> <td>10</td> <td>16</td> <td>25</td> <td>35</td> <td>50</td> <td>63</td> <td>80</td> <td>100</td> </tr> <tr> <td rowspan="2">Impedance ratio (max.)</td> <td>Z-25°C/Z+20°C</td> <td>2</td> <td>2</td> <td>2</td> <td>2</td> <td>2</td> <td>2</td> <td>2</td> <td>2</td> </tr> <tr> <td>Z-40°C/Z+20°C</td> <td>3</td> <td>3</td> <td>3</td> <td>3</td> <td>3</td> <td>3</td> <td>3</td> <td>3</td> </tr> </table> <p>(120Hz)</p> | Rated voltage (V) | 6.3 | 10 | 16 | 25 | 35 | 50 | 63 | 80 | 100 | Impedance ratio (max.) | Z-25°C/Z+20°C | 2 | 2 | 2 | 2 | 2 | 2 | 2 | 2 | Z-40°C/Z+20°C | 3 | 3 | 3 | 3 | 3 | 3 | 3 | 3 |
| Rated voltage (V) | 6.3 | 10 | 16 | 25 | 35 | 50 | 63 | 80 | 100 | | | | | | | | | | | | | | | | | | | | | |
| Impedance ratio (max.) | Z-25°C/Z+20°C | 2 | 2 | 2 | 2 | 2 | 2 | 2 | 2 | | | | | | | | | | | | | | | | | | | | | |
| | Z-40°C/Z+20°C | 3 | 3 | 3 | 3 | 3 | 3 | 3 | 3 | | | | | | | | | | | | | | | | | | | | | |
| Endurance (105°C) (Applied ripple current) | <table border="1"> <tr> <td>Test time</td> <td>5L & 7L : 1000 hours φ5 & φ6.3 : 2000 hours (63 to 100WV:5000 hours) φ8 & φ10 : 3000 hours (63 to 100WV:7000 hours) φ12.5 to φ18 : 5000 hours (63 to 100WV:10000 hours)</td> </tr> <tr> <td>Leakage current</td> <td>The initial specified value or less</td> </tr> <tr> <td>Percentage of capacitance change</td> <td>Within ±25% of initial value</td> </tr> <tr> <td>Tangent of the loss angle</td> <td>200% or less of the initial specified value</td> </tr> </table> | Test time | 5L & 7L : 1000 hours φ5 & φ6.3 : 2000 hours (63 to 100WV:5000 hours) φ8 & φ10 : 3000 hours (63 to 100WV:7000 hours) φ12.5 to φ18 : 5000 hours (63 to 100WV:10000 hours) | Leakage current | The initial specified value or less | Percentage of capacitance change | Within ±25% of initial value | Tangent of the loss angle | 200% or less of the initial specified value | | | | | | | | | | | | | | | | | | | | | |
| Test time | 5L & 7L : 1000 hours φ5 & φ6.3 : 2000 hours (63 to 100WV:5000 hours) φ8 & φ10 : 3000 hours (63 to 100WV:7000 hours) φ12.5 to φ18 : 5000 hours (63 to 100WV:10000 hours) | | | | | | | | | | | | | | | | | | | | | | | | | | | | | |
| Leakage current | The initial specified value or less | | | | | | | | | | | | | | | | | | | | | | | | | | | | | |
| Percentage of capacitance change | Within ±25% of initial value | | | | | | | | | | | | | | | | | | | | | | | | | | | | | |
| Tangent of the loss angle | 200% or less of the initial specified value | | | | | | | | | | | | | | | | | | | | | | | | | | | | | |
| Shelf life (105°C) | <table border="1"> <tr> <td>Test time</td> <td>1000 hours</td> </tr> <tr> <td>Leakage current</td> <td>The initial specified value or less</td> </tr> <tr> <td>Percentage of capacitance change</td> <td>Within ±25% of initial value</td> </tr> <tr> <td>Tangent of the loss angle</td> <td>200% or less of the initial specified value</td> </tr> </table> <p>Voltage application treatment</p> | Test time | 1000 hours | Leakage current | The initial specified value or less | Percentage of capacitance change | Within ±25% of initial value | Tangent of the loss angle | 200% or less of the initial specified value | | | | | | | | | | | | | | | | | | | | | |
| Test time | 1000 hours | | | | | | | | | | | | | | | | | | | | | | | | | | | | | |
| Leakage current | The initial specified value or less | | | | | | | | | | | | | | | | | | | | | | | | | | | | | |
| Percentage of capacitance change | Within ±25% of initial value | | | | | | | | | | | | | | | | | | | | | | | | | | | | | |
| Tangent of the loss angle | 200% or less of the initial specified value | | | | | | | | | | | | | | | | | | | | | | | | | | | | | |
| Applicable standards | JIS C5101-1, -4 1998 (IEC 60384-1 1992, -4 1985) | | | | | | | | | | | | | | | | | | | | | | | | | | | | | |

MINIATURE ALUMINUM

Outline Drawing

Unit : mm

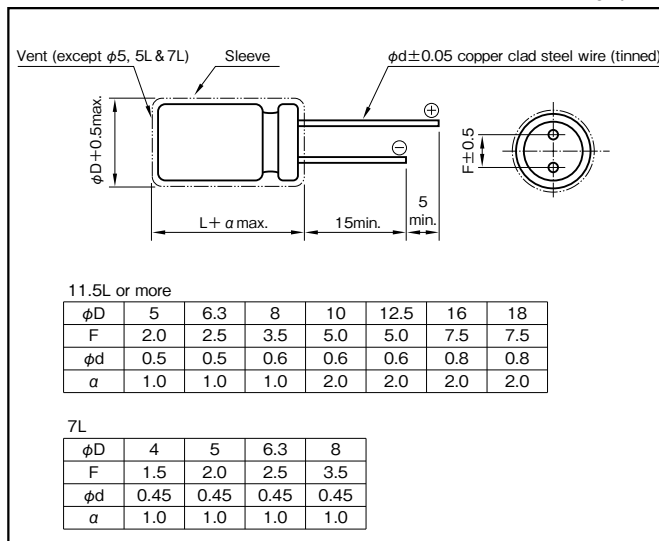

Coefficient of Frequency for Rated Ripple Current

| Rated capacitance (µF) \ Frequency (Hz) | 120 | 1k | 10k | 100k |
|---|------|------|------|------|
| 5.6 to 180 | 0.40 | 0.75 | 0.90 | 1 |
| 220 to 390 | 0.50 | 0.85 | 0.94 | 1 |
| 470 to 1800 | 0.60 | 0.87 | 0.95 | 1 |
| 2200 to 3900 | 0.75 | 0.90 | 0.95 | 1 |
| 4700 to 6800 | 0.85 | 0.95 | 0.98 | 1 |

Part numbering system (example : 10V1000µF)

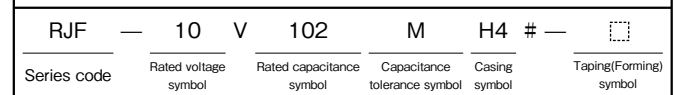

- The electric characteristics are described on page 183.

- The standard ratings are described on the next page.

NOTE : Design, Specifications are subject to change without notice. It is recommended that you shall obtain technical specifications from ELNA to ensure that the component is suitable for your use.

Standard Ratings

| Rated voltage (V) | Item | 6.3 | | | | | 10 | | | | | 16 | | | | |
|-------------------|------|----------|---------------|--------------------|-------|-------------------------------|----------|---------------|--------------------|-------|-------------------------------|----------|---------------|--------------------|-------|-------------------------------|
| | | Case | Casing symbol | Impedance (Ω max.) | | Rated ripple current (mA rms) | Case | Casing symbol | Impedance (Ω max.) | | Rated ripple current (mA rms) | Case | Casing symbol | Impedance (Ω max.) | | Rated ripple current (mA rms) |
| | | | | 20°C | -10°C | | | | 20°C | -10°C | | | | 20°C | -10°C | |
| | 18 | — | — | — | — | — | — | — | — | — | 4×7 | D1 | 0.92 | 2.8 | 130 | |
| | 27 | — | — | — | — | 4×7 | D1 | 0.89 | 2.7 | 130 | 6.3×5 | F0 | 0.30 | 0.95 | 210 | |
| | 33 | — | — | — | — | — | — | — | — | — | 5×7 | E1 | 0.45 | 1.4 | 210 | |
| | | | | | | | | | | | 6.3×5 | F0 | 0.30 | 0.95 | 210 | |
| | 39 | 4×7 | D1 | 0.85 | 2.6 | 130 | — | — | — | — | — | — | — | — | — | |
| | 47 | — | — | — | — | — | 6.3×5 | F0 | 0.29 | 0.93 | 210 | — | — | — | — | — |
| | 56 | — | — | — | — | — | 5×7 | E1 | 0.44 | 1.4 | 210 | 5×11.5 | E3 | 0.22 | 0.80 | 345 |
| | 68 | 5×7 | E1 | 0.43 | 1.3 | 210 | — | — | — | — | 6.3×7 | F1 | 0.24 | 0.72 | 300 | |
| | 100 | 6.3×5 | F0 | 0.28 | 0.91 | 210 | 5×11.5 | E3 | 0.22 | 0.8 | 345 | — | — | — | — | — |
| | 120 | — | — | — | — | — | 6.3×7 | F1 | 0.23 | 0.69 | 300 | 8×7 | G1 | 0.15 | 0.45 | 380 |
| | | | | | | | | | | | | 6.3×11.5 | F3 | 0.094 | 0.35 | 540 |
| | 150 | 5×11.5 | E3 | 0.22 | 0.80 | 345 | — | — | — | — | — | — | — | — | — | — |
| | | 6.3×7 | F1 | 0.23 | 0.69 | 300 | — | — | — | — | — | — | — | — | — | — |
| | 180 | — | — | — | — | — | 8×7 | G1 | 0.15 | 0.45 | 380 | — | — | — | — | — |
| | 220 | 8×7 | G1 | 0.15 | 0.45 | 380 | 6.3×11.5 | F3 | 0.094 | 0.35 | 540 | — | — | — | — | — |
| | 330 | 6.3×11.5 | F3 | 0.094 | 0.35 | 540 | — | — | — | — | 8×12 | G3 | 0.056 | 0.19 | 945 | |
| | 470 | — | — | — | — | — | 8×12 | G3 | 0.056 | 0.19 | 945 | 8×15 | G4 | 0.045 | 0.15 | 1250 |
| | 560 | 8×12 | G3 | 0.056 | 0.19 | 945 | — | — | — | — | 10×16 | H4 | 0.028 | 0.10 | 1760 | |
| | 680 | — | — | — | — | — | 10×12.5 | H3 | 0.039 | 0.14 | 1330 | — | — | — | — | — |
| | 820 | 8×15 | G4 | 0.046 | 0.15 | 1250 | — | — | — | — | — | — | — | — | — | — |
| | 1000 | 10×12.5 | H3 | 0.039 | 0.14 | 1330 | 10×16 | H4 | 0.028 | 0.10 | 1760 | 10×20 | H5 | 0.020 | 0.060 | 1960 |
| | 1200 | 10×16 | H4 | 0.028 | 0.10 | 1760 | 10×20 | H5 | 0.020 | 0.060 | 1960 | 10×25 | H6 | 0.018 | 0.054 | 2250 |
| | 1500 | 10×20 | H5 | 0.020 | 0.060 | 1960 | 10×25 | H6 | 0.018 | 0.054 | 2250 | 12.5×20 | I5 | 0.017 | 0.043 | 2480 |
| | 2200 | 10×25 | H6 | 0.018 | 0.054 | 2250 | 12.5×20 | I5 | 0.017 | 0.043 | 2480 | 12.5×25 | I6 | 0.015 | 0.038 | 2900 |
| | 2700 | — | — | — | — | — | — | — | — | — | 16×20 | J5 | 0.015 | 0.038 | 3250 | |
| | 3300 | 12.5×20 | I5 | 0.017 | 0.043 | 2480 | 12.5×25 | I6 | 0.015 | 0.038 | 2900 | 16×25 | J6 | 0.013 | 0.035 | 3630 |
| | 3900 | 12.5×25 | I6 | 0.015 | 0.038 | 2900 | 16×20 | J5 | 0.015 | 0.038 | 3250 | 16×25 | J6 | 0.013 | 0.035 | 3630 |
| | 4700 | 12.5×30 | I7 | 0.013 | 0.033 | 3450 | 16×25 | J6 | 0.013 | 0.035 | 3630 | — | — | — | — | — |
| | 5600 | 16×20 | J5 | 0.015 | 0.038 | 3570 | 16×25 | J6 | 0.013 | 0.035 | 3630 | — | — | — | — | — |
| | 6800 | 16×25 | J6 | 0.013 | 0.035 | 3630 | — | — | — | — | — | — | — | — | — | — |

| Rated voltage (V) | Item | 25 | | | | | 35 | | | | | 50 | | | | |
|-------------------|------|----------|---------------|--------------------|-------|-------------------------------|----------|---------------|--------------------|-------|-------------------------------|----------|---------------|--------------------|-------|-------------------------------|
| | | Case | Casing symbol | Impedance (Ω max.) | | Rated ripple current (mA rms) | Case | Casing symbol | Impedance (Ω max.) | | Rated ripple current (mA rms) | Case | Casing symbol | Impedance (Ω max.) | | Rated ripple current (mA rms) |
| | | | | 20°C | -10°C | | | | 20°C | -10°C | | | | 20°C | -10°C | |
| | 5.6 | — | — | — | — | — | — | — | — | — | 4×7 | D1 | 1.0 | 3.0 | 130 | |
| | 10 | 5×5 | E0 | 0.61 | 1.5 | 130 | 5×5 | E0 | 0.63 | 1.5 | 130 | 5×7 | E1 | 0.50 | 1.5 | 210 |
| | | 4×7 | D1 | 0.94 | 2.9 | 130 | 4×7 | D1 | 0.96 | 2.9 | 130 | | | | | |
| | 15 | 4×7 | D1 | 0.94 | 2.9 | 130 | — | — | — | — | — | — | — | — | — | — |
| | 18 | — | — | — | — | — | 5×7 | E1 | 0.47 | 1.5 | 210 | — | — | — | — | — |
| | 22 | 6.3×5 | F0 | 0.31 | 0.97 | 210 | 6.3×5 | F0 | 0.32 | 1.0 | 210 | 6.3×7 | F1 | 0.26 | 0.78 | 300 |
| | | | | | | | | | | | | 5×11.5 | E3 | 0.34 | 1.18 | 238 |
| | 27 | 5×7 | E1 | 0.46 | 1.4 | 210 | — | — | — | — | — | — | — | — | — | — |
| | 33 | — | — | — | — | — | 5×11.5 | E3 | 0.22 | 0.80 | 345 | 8×7 | G1 | 0.17 | 0.51 | 380 |
| | 39 | — | — | — | — | — | 6.3×7 | F1 | 0.25 | 0.75 | 300 | — | — | — | — | — |
| | 47 | 5×11.5 | E3 | 0.22 | 0.80 | 345 | — | — | — | — | — | — | — | — | — | — |
| | 56 | 6.3×7 | F1 | 0.24 | 0.72 | 300 | 8×7 | G1 | 0.16 | 0.48 | 380 | 6.3×11.5 | F3 | 0.14 | 0.50 | 385 |
| | | | | | | | 6.3×11.5 | F3 | 0.094 | 0.35 | 540 | | | | | |
| | 100 | 8×7 | G1 | 0.15 | 0.45 | 380 | — | — | — | — | 8×12 | G3 | 0.074 | 0.22 | 724 | |
| | | 6.3×11.5 | F3 | 0.13 | 0.41 | 405 | — | — | — | — | — | — | — | — | — | — |
| | 120 | — | — | — | — | — | — | — | — | — | 8×15 | G4 | 0.061 | 0.18 | 950 | |
| | 150 | — | — | — | — | — | 8×12 | G3 | 0.056 | 0.19 | 945 | 10×12.5 | H3 | 0.061 | 0.18 | 979 |
| | 180 | — | — | — | — | — | — | — | — | — | 8×20 | G5 | 0.046 | 0.14 | 1190 | |
| | 220 | 8×12 | G3 | 0.056 | 0.19 | 945 | 10×12.5 | H3 | 0.039 | 0.14 | 1330 | 10×16 | H4 | 0.042 | 0.12 | 1370 |
| | 270 | — | — | — | — | — | 8×20 | G5 | 0.029 | 0.11 | 1500 | 10×20 | H5 | 0.030 | 0.090 | 1580 |
| | 330 | 10×12.5 | H3 | 0.039 | 0.14 | 1330 | 10×16 | H4 | 0.028 | 0.10 | 1760 | 10×25 | H6 | 0.028 | 0.085 | 1870 |
| | 470 | 10×16 | H4 | 0.028 | 0.10 | 1760 | 10×20 | H5 | 0.020 | 0.060 | 1960 | 12.5×20 | I5 | 0.027 | 0.068 | 2050 |
| | 560 | — | — | — | — | — | 10×25 | H6 | 0.018 | 0.054 | 2250 | 12.5×25 | I6 | 0.023 | 0.059 | 2410 |
| | 680 | 10×20 | H5 | 0.020 | 0.060 | 1960 | 12.5×20 | I5 | 0.017 | 0.043 | 2480 | 16×20 | J5 | 0.023 | 0.059 | 2730 |
| | 820 | 10×25 | H6 | 0.018 | 0.054 | 2250 | — | — | — | — | 16×20 | J5 | 0.023 | 0.059 | 2730 | |
| | 1000 | 12.5×20 | I5 | 0.017 | 0.043 | 2480 | 12.5×25 | I6 | 0.015 | 0.038 | 2900 | 16×25 | J6 | 0.021 | 0.056 | 3010 |
| | 1200 | — | — | — | — | — | 16×20 | J5 | 0.015 | 0.038 | 3250 | — | — | — | — | — |
| | 1500 | 12.5×25 | I6 | 0.015 | 0.038 | 2900 | 16×25 | J6 | 0.013 | 0.035 | 3630 | — | — | — | — | — |
| | 1800 | 16×20 | J5 | 0.015 | 0.038 | 3250 | 16×25 | J6 | 0.013 | 0.035 | 3630 | — | — | — | — | — |
| | 2200 | 16×25 | J6 | 0.013 | 0.035 | 3630 | — | — | — | — | — | — | — | — | — | — |
| | 2700 | 16×25 | J6 | 0.013 | 0.035 | 3630 | — | — | — | — | — | — | — | — | — | — |

(Note) Rated ripple current : 105°C, 100kHz ; Impedance : 100kHz

Standard Ratings

| Rated voltage (V) Rated capacitance (µF) | Item | 63 | | | | 80 | | | | 100 | | | | | |
|---|------------|-----------------|---------------|--------------------|-------|-----------------|---------------|--------------------|-------|-----------------|---------------|--------------------|-------|-------------------------------|---------|
| | | Case φ DxL (mm) | Casing symbol | Impedance (Ω max.) | | Case φ DxL (mm) | Casing symbol | Impedance (Ω max.) | | Case φ DxL (mm) | Casing symbol | Impedance (Ω max.) | | Rated ripple current (mA rms) | |
| | | | | 20°C | -10°C | | | 20°C | -10°C | | | 20°C | -10°C | | |
| 6.8 | — | — | — | — | — | — | — | — | — | — | 5 × 11.5 | E3 | 1.4 | 5.6 | 125 |
| 15 | 5 × 11.5 | E3 | 0.88 | 3.5 | 165 | — | — | — | — | — | 6.3 × 11.5 | F3 | 0.57 | 2.3 | 205 |
| 27 | — | — | — | — | — | — | — | — | — | — | 8 × 12 | G3 | 0.36 | 1.4 | 335 |
| 33 | 6.3 × 11.5 | F3 | 0.35 | 1.4 | 265 | — | — | — | — | — | — | — | — | — | — |
| 39 | — | — | — | — | — | — | — | — | — | — | 8 × 15 | G4 | 0.25 | 1.0 | 450 |
| 47 | — | — | — | — | — | — | — | — | — | — | 10 × 12.5 | H3 | 0.17 | 0.66 | 480 |
| 56 | 8 × 12 | G3 | 0.22 | 0.88 | 500 | — | — | — | — | — | 8 × 20 | G5 | 0.19 | 0.76 | 565 |
| 68 | — | — | — | — | — | 10 × 12.5 | H3 | 0.17 | 0.66 | 480 | 10 × 16 | H4 | 0.11 | 0.47 | 600 |
| 82 | 10 × 12.5 | H3 | 0.11 | 0.44 | 690 | — | — | — | — | — | 10 × 20 | H5 | 0.084 | 0.34 | 800 |
| 100 | — | — | — | — | — | 10 × 16 | H4 | 0.11 | 0.47 | 600 | 12.5 × 15 | I4 | 0.11 | 0.34 | 750 |
| 120 | 8 × 20 | G5 | 0.12 | 0.48 | 820 | 10 × 20 | H5 | 0.084 | 0.34 | 800 | 10 × 25 | H6 | 0.069 | 0.28 | 900 |
| | 10 × 16 | H4 | 0.076 | 0.31 | 950 | | | | | | | | | | |
| 150 | — | — | — | — | — | 10 × 25 | H6 | 0.069 | 0.28 | 900 | 12.5 × 20 | I5 | 0.062 | 0.18 | 1100 |
| 180 | 10 × 20 | H5 | 0.056 | 0.23 | 1150 | — | — | — | — | — | — | — | — | — | — |
| 220 | 10 × 25 | H6 | 0.046 | 0.19 | 1350 | 12.5 × 20 | I5 | 0.062 | 0.18 | 1100 | 16 × 20 | J5 | 0.048 | 0.15 | 1350 |
| 270 | 12.5 × 20 | I5 | 0.041 | 0.13 | 1500 | — | — | — | — | — | 12.5 × 30 | I7 | 0.042 | 0.13 | 1500 |
| 330 | — | — | — | — | — | 12.5 × 25 | I6 | 0.047 | 0.14 | 1250 | 12.5 × 35 | I8 | 0.036 | 0.11 | 1650 |
| | | | | | | 16 × 20 | J5 | 0.048 | 0.15 | 1350 | 16 × 25 | J6 | 0.038 | 0.12 | 1700 |
| | | | | | | — | — | — | — | — | — | — | — | — | 18 × 20 |
| 390 | 12.5 × 25 | I6 | 0.031 | 0.093 | 1900 | 12.5 × 30 | I7 | 0.042 | 0.13 | 1500 | 12.5 × 40 | I9 | 0.032 | 0.095 | 1800 |
| 470 | 12.5 × 30 | I7 | 0.028 | 0.084 | 2300 | 12.5 × 35 | I8 | 0.036 | 0.11 | 1650 | 16 × 31.5 | J7 | 0.032 | 0.095 | 1850 |
| | 16 × 20 | J5 | 0.032 | 0.096 | 2000 | 16 × 25 | J6 | 0.038 | 0.12 | 1700 | | | | | |
| | — | — | — | — | — | 18 × 20 | K5 | 0.045 | 0.14 | 1500 | | | | | |
| 560 | 12.5 × 35 | I8 | 0.024 | 0.070 | 2500 | — | — | — | — | — | 16 × 35.5 | J8 | 0.029 | 0.086 | 2000 |
| | | | | | | | | | | | 18 × 31.5 | K7 | 0.030 | 0.090 | 1900 |
| 680 | 12.5 × 40 | I9 | 0.021 | 0.063 | 2800 | 16 × 31.5 | J7 | 0.032 | 0.095 | 1850 | 16 × 40 | J9 | 0.027 | 0.081 | 2480 |
| | 16 × 25 | J6 | 0.025 | 0.075 | 2600 | | | | | | 18 × 35.5 | K8 | 0.027 | 0.081 | 2200 |
| | 18 × 20 | K5 | 0.030 | 0.090 | 2500 | | | | | | — | — | — | — | — |
| 820 | 16 × 31.5 | J7 | 0.021 | 0.063 | 2850 | 16 × 35.5 | J8 | 0.029 | 0.086 | 2000 | 18 × 40 | K9 | 0.026 | 0.077 | 2700 |
| | 18 × 25 | K6 | 0.024 | 0.072 | 2800 | 18 × 31.5 | K7 | 0.030 | 0.090 | 1900 | | | | | |
| 1000 | 16 × 35.5 | J8 | 0.019 | 0.057 | 2900 | — | — | — | — | — | — | — | — | — | — |
| 1200 | 16 × 40 | J9 | 0.018 | 0.054 | 3400 | 18 × 40 | K9 | 0.026 | 0.077 | 2700 | — | — | — | — | — |
| | 18 × 31.5 | K7 | 0.020 | 0.060 | 3300 | | | | | | — | — | — | — | — |
| 1500 | 18 × 35.5 | K8 | 0.018 | 0.054 | 3400 | — | — | — | — | — | — | — | — | — | — |
| 1800 | 18 × 40 | K9 | 0.017 | 0.051 | 3500 | — | — | — | — | — | — | — | — | — | — |

(Note) Rated ripple current : 105°C , 100kHz ; Impedance : 100kHz

105°C Use, Miniature, Long Life, extra Low Impedance Capacitors

GREEN CAP

Low Impedance

105°C 10000hours

Anti-cleaning solvent

- Long life than RJF series.
- Guarantees 4000 to 10000 hours at 105°C.

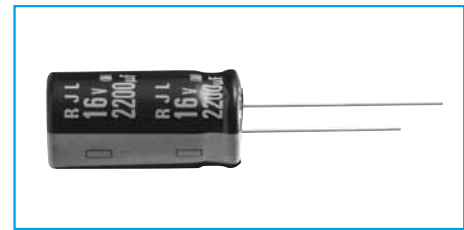
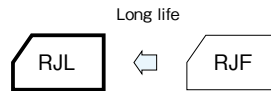

Marking color : White print on a black sleeve

Specifications

| Item | Performance | | | | | | | | | | | | | | | | | | | | | | | | | | |
|---|---|--|------|------|------|------|------|------|-----|-----|------------------------|---------------|------|------|------|------|------|------|------|---------------|---|---|---|---|---|---|---|
| Category temperature range (°C) | -40 to +105 | | | | | | | | | | | | | | | | | | | | | | | | | | |
| Tolerance at rated capacitance (%) | ±20 (20°C, 120Hz) | | | | | | | | | | | | | | | | | | | | | | | | | | |
| Leakage current (µA) | Less than 0.01CV or 3 whichever is larger (after 2 minutes) C : Rated capacitance (µF), V : Rated voltage (V) (20°C) | | | | | | | | | | | | | | | | | | | | | | | | | | |
| Tangent of loss angle (tanδ) | <table border="1"> <thead> <tr> <th>Rated voltage (V)</th> <th>6.3</th> <th>10</th> <th>16</th> <th>25</th> <th>35</th> <th>50</th> <th>63</th> <th>100</th> </tr> </thead> <tbody> <tr> <td>tanδ (max.)</td> <td>0.22</td> <td>0.19</td> <td>0.16</td> <td>0.14</td> <td>0.12</td> <td>0.10</td> <td>0.09</td> <td>0.08</td> </tr> </tbody> </table> | Rated voltage (V) | 6.3 | 10 | 16 | 25 | 35 | 50 | 63 | 100 | tanδ (max.) | 0.22 | 0.19 | 0.16 | 0.14 | 0.12 | 0.10 | 0.09 | 0.08 | | | | | | | | |
| | Rated voltage (V) | 6.3 | 10 | 16 | 25 | 35 | 50 | 63 | 100 | | | | | | | | | | | | | | | | | | |
| tanδ (max.) | 0.22 | 0.19 | 0.16 | 0.14 | 0.12 | 0.10 | 0.09 | 0.08 | | | | | | | | | | | | | | | | | | | |
| 0.02 is added to every 1000µF increase over 1000µF. (20°C, 120Hz) | | | | | | | | | | | | | | | | | | | | | | | | | | | |
| Characteristics at high and low temperature | <table border="1"> <thead> <tr> <th>Rated voltage (V)</th> <th>6.3</th> <th>10</th> <th>16</th> <th>25</th> <th>35</th> <th>50</th> <th>63</th> <th>100</th> </tr> </thead> <tbody> <tr> <td rowspan="2">Impedance ratio (max.)</td> <td>Z-25°C/Z+20°C</td> <td>4</td> <td>3</td> <td>2</td> <td>2</td> <td>2</td> <td>2</td> <td>2</td> </tr> <tr> <td>Z-40°C/Z+20°C</td> <td>8</td> <td>6</td> <td>4</td> <td>3</td> <td>3</td> <td>3</td> <td>3</td> </tr> </tbody> </table> | Rated voltage (V) | 6.3 | 10 | 16 | 25 | 35 | 50 | 63 | 100 | Impedance ratio (max.) | Z-25°C/Z+20°C | 4 | 3 | 2 | 2 | 2 | 2 | 2 | Z-40°C/Z+20°C | 8 | 6 | 4 | 3 | 3 | 3 | 3 |
| | Rated voltage (V) | 6.3 | 10 | 16 | 25 | 35 | 50 | 63 | 100 | | | | | | | | | | | | | | | | | | |
| Impedance ratio (max.) | Z-25°C/Z+20°C | 4 | 3 | 2 | 2 | 2 | 2 | 2 | | | | | | | | | | | | | | | | | | | |
| | Z-40°C/Z+20°C | 8 | 6 | 4 | 3 | 3 | 3 | 3 | | | | | | | | | | | | | | | | | | | |
| (120Hz) | | | | | | | | | | | | | | | | | | | | | | | | | | | |
| Endurance (105°C) (Applied ripple current) | Test time | φ5 & φ6.3 : 5000 hours (6.3~10WV : 4000 hours) φ8 & φ10 : 7000 hours (6.3~10WV : 6000 hours) φ12.5 & φ16 : 10000 hours (6.3~10WV : 8000 hours) | | | | | | | | | | | | | | | | | | | | | | | | | |
| | Leakage current | The initial specified value or less | | | | | | | | | | | | | | | | | | | | | | | | | |
| | Percentage of capacitance change | Within ±25% of initial value | | | | | | | | | | | | | | | | | | | | | | | | | |
| | Tangent of the loss angle | 200% or less of the initial specified value | | | | | | | | | | | | | | | | | | | | | | | | | |
| Shelf life (105°C) | Test time | 1000 hours | | | | | | | | | | | | | | | | | | | | | | | | | |
| | Leakage current | The initial specified value or less | | | | | | | | | | | | | | | | | | | | | | | | | |
| | Percentage of capacitance change | Within ±25% of initial value | | | | | | | | | | | | | | | | | | | | | | | | | |
| | Tangent of the loss angle | 200% or less of initial specified value | | | | | | | | | | | | | | | | | | | | | | | | | |
| Voltage application treatment | | | | | | | | | | | | | | | | | | | | | | | | | | | |
| Applicable standards | JIS C5101-1, -4 1998 (IEC 60384-1 1992, -4 1985) | | | | | | | | | | | | | | | | | | | | | | | | | | |

Outline Drawing

Unit : mm

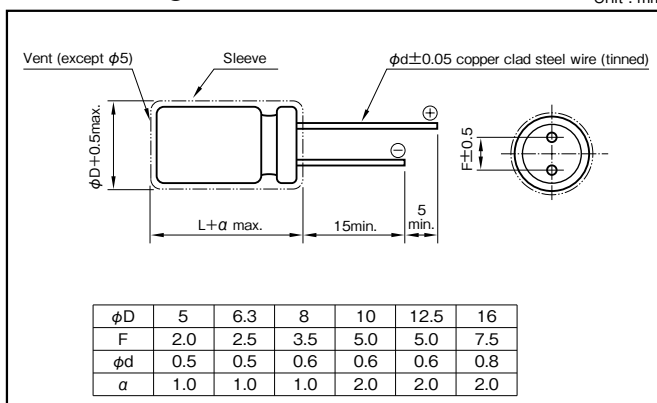

Coefficient of Frequency for Rated Ripple Current

| Rated capacitance (µF) | Frequency (Hz) | | | |
|------------------------|----------------|------|------|------|
| | 120 | 1k | 10k | 100k |
| to 33 | 0.42 | 0.70 | 0.90 | 1 |
| 47 to 270 | 0.50 | 0.73 | 0.92 | 1 |
| 330 to 680 | 0.55 | 0.77 | 0.94 | 1 |
| 820 to 1800 | 0.60 | 0.80 | 0.96 | 1 |
| 2200 to 6800 | 0.70 | 0.85 | 0.98 | 1 |

Part numbering system (example : 10V1000µF)

| | | | | | | | | | |
|-------------|---|----------------------|---|--------------------------|------------------------------|---------------|---|---|------------------------|
| RJL | — | 10 | V | 102 | M | H4 | # | — | □ |
| Series code | | Rated voltage symbol | | Rated capacitance symbol | Capacitance tolerance symbol | Casing symbol | | | Taping(Forming) symbol |

Standard Ratings

| Rated voltage (V) | Item | 6.3 | | | | | 10 | | | | | 16 | | | | |
|-------------------|----------|-------------------|------------------|--------------------|-------|------------------------------------|-------------------|------------------|--------------------|-------|------------------------------------|-------------------|------------------|--------------------|-------|------------------------------------|
| | | Case φD×L (mm) | Casing symbol | Impedance (Ω max.) | | Rated ripple current (mArms) | Case φD×L (mm) | Casing symbol | Impedance (Ω max.) | | Rated ripple current (mArms) | Case φD×L (mm) | Casing symbol | Impedance (Ω max.) | | Rated ripple current (mArms) |
| | | | | 20°C | -10°C | | | | 20°C | -10°C | | | | 20°C | -10°C | |
| 56 | — | — | — | — | — | — | — | — | — | — | 5×11.5 | E3 | 0.58 | 2.3 | 210 | |
| 100 | — | — | — | — | — | 5×11.5 | E3 | 0.58 | 2.3 | 210 | — | — | — | — | — | |
| 120 | — | — | — | — | — | — | — | — | — | — | 6.3×11.5 | F3 | 0.22 | 0.87 | 340 | |
| 150 | 5×11.5 | E3 | 0.58 | 2.3 | 210 | — | — | — | — | — | — | — | — | — | — | |
| 220 | — | — | — | — | — | 6.3×11.5 | F3 | 0.22 | 0.87 | 340 | — | — | — | — | — | |
| 330 | 6.3×11.5 | F3 | 0.22 | 0.87 | 340 | — | — | — | — | — | 8×12 | G3 | 0.13 | 0.52 | 640 | |
| 470 | — | — | — | — | — | 8×12 | G3 | 0.13 | 0.52 | 640 | 8×15 | G4 | 0.087 | 0.35 | 840 | |
| 560 | 8×12 | G3 | 0.13 | 0.52 | 640 | 8×15 | G4 | 0.087 | 0.35 | 840 | — | — | — | — | — | |
| 680 | 8×12 | G3 | 0.13 | 0.52 | 640 | 10×12.5 | H3 | 0.080 | 0.32 | 865 | 10×16 | H4 | 0.060 | 0.24 | 1210 | |
| 820 | 10×12.5 | H3 | 0.080 | 0.32 | 865 | 10×16 | H4 | 0.060 | 0.24 | 1210 | 10×20 | H5 | 0.046 | 0.18 | 1400 | |
| 1000 | 8×15 | G4 | 0.087 | 0.35 | 840 | 10×16 | H4 | 0.060 | 0.24 | 1210 | 10×20 | H5 | 0.046 | 0.18 | 1400 | |
| 1200 | 10×16 | H4 | 0.060 | 0.24 | 1210 | 10×20 | H5 | 0.046 | 0.18 | 1400 | 10×25 | H6 | 0.042 | 0.17 | 1650 | |
| 1500 | 10×20 | H5 | 0.046 | 0.18 | 1400 | 10×25 | H6 | 0.042 | 0.17 | 1650 | 12.5×20 | I5 | 0.035 | 0.12 | 1900 | |
| 1800 | 10×25 | H6 | 0.042 | 0.17 | 1650 | 12.5×20 | I5 | 0.035 | 0.12 | 1900 | 12.5×25 | I6 | 0.027 | 0.089 | 2230 | |
| 2200 | 10×25 | H6 | 0.042 | 0.17 | 1650 | 12.5×20 | I5 | 0.035 | 0.12 | 1900 | 12.5×25 | I6 | 0.027 | 0.089 | 2230 | |
| 2700 | — | — | — | — | — | — | — | — | — | — | 16×20 | J5 | 0.027 | 0.078 | 2530 | |
| 3300 | 12.5×20 | I5 | 0.035 | 0.12 | 1900 | 12.5×25 | I6 | 0.027 | 0.089 | 2230 | 12.5×35 | I8 | 0.020 | 0.065 | 2880 | |
| 3900 | — | — | — | — | — | — | — | — | — | — | 16×25 | J6 | 0.021 | 0.060 | 2930 | |
| 4700 | 12.5×30 | I7 | 0.024 | 0.078 | 2650 | 12.5×35 | I8 | 0.020 | 0.065 | 2880 | — | — | — | — | — | |
| 5600 | 16×20 | J5 | 0.027 | 0.078 | 2530 | 16×25 | J6 | 0.021 | 0.060 | 2930 | — | — | — | — | — | |
| 6800 | 16×25 | J6 | 0.021 | 0.060 | 2930 | — | — | — | — | — | — | — | — | — | — | |

| Rated voltage (V) | Item | 25 | | | | | 35 | | | | | 50 | | | | |
|-------------------|----------|-------------------|------------------|--------------------|-------|------------------------------------|-------------------|------------------|--------------------|-------|------------------------------------|-------------------|------------------|--------------------|-------|------------------------------------|
| | | Case φD×L (mm) | Casing symbol | Impedance (Ω max.) | | Rated ripple current (mArms) | Case φD×L (mm) | Casing symbol | Impedance (Ω max.) | | Rated ripple current (mArms) | Case φD×L (mm) | Casing symbol | Impedance (Ω max.) | | Rated ripple current (mArms) |
| | | | | 20°C | -10°C | | | | 20°C | -10°C | | | | 20°C | -10°C | |
| 10 | — | — | — | — | — | — | — | — | — | — | 5×11.5 | E3 | 1.50 | 6.0 | 100 | |
| 22 | — | — | — | — | — | — | — | — | — | — | 5×11.5 | E3 | 0.70 | 2.8 | 180 | |
| 33 | — | — | — | — | — | 5×11.5 | E3 | 0.58 | 2.3 | 210 | — | — | — | — | — | |
| 47 | 5×11.5 | E3 | 0.58 | 2.3 | 210 | — | — | — | — | — | — | — | — | — | — | |
| 56 | — | — | — | — | — | 6.3×11.5 | F3 | 0.22 | 0.87 | 340 | 6.3×11.5 | F3 | 0.30 | 1.2 | 295 | |
| 100 | 6.3×11.5 | F3 | 0.22 | 0.87 | 340 | — | — | — | — | — | 8×12 | G3 | 0.17 | 0.68 | 555 | |
| 120 | — | — | — | — | — | — | — | — | — | — | 8×15 | G4 | 0.12 | 0.48 | 730 | |
| 150 | — | — | — | — | — | 8×12 | G3 | 0.13 | 0.52 | 640 | 10×12.5 | H3 | 0.12 | 0.48 | 760 | |
| 180 | — | — | — | — | — | 8×15 | G4 | 0.087 | 0.35 | 870 | 8×20 | G5 | 0.091 | 0.36 | 910 | |
| 220 | 8×12 | G3 | 0.13 | 0.52 | 640 | 8×15 | G4 | 0.087 | 0.35 | 870 | 10×16 | H4 | 0.084 | 0.34 | 1050 | |
| 270 | — | — | — | — | — | 8×20 | G5 | 0.069 | 0.27 | 1050 | 10×20 | H5 | 0.060 | 0.24 | 1220 | |
| 330 | 8×15 | G4 | 0.087 | 0.35 | 840 | 10×16 | H4 | 0.060 | 0.24 | 1210 | 10×25 | H6 | 0.055 | 0.22 | 1440 | |
| 470 | 10×16 | H4 | 0.060 | 0.24 | 1210 | 10×20 | H5 | 0.046 | 0.18 | 1400 | 12.5×20 | I5 | 0.045 | 0.15 | 1660 | |
| 560 | — | — | — | — | — | 10×25 | H6 | 0.042 | 0.17 | 1650 | 12.5×25 | I6 | 0.034 | 0.11 | 1950 | |
| 680 | 10×20 | H5 | 0.046 | 0.18 | 1400 | 12.5×20 | I5 | 0.035 | 0.12 | 1900 | 12.5×25 | I6 | 0.034 | 0.11 | 1950 | |
| 820 | 10×25 | H6 | 0.042 | 0.17 | 1650 | 12.5×25 | I6 | 0.027 | 0.089 | 2230 | 12.5×30 | I7 | 0.030 | 0.10 | 2310 | |
| 1000 | 12.5×20 | I5 | 0.035 | 0.12 | 1900 | 12.5×25 | I6 | 0.027 | 0.089 | 2230 | 16×25 | J6 | 0.025 | 0.075 | 2555 | |
| 1200 | 12.5×25 | I6 | 0.027 | 0.089 | 2230 | 16×20 | J5 | 0.027 | 0.078 | 2530 | — | — | — | — | — | |
| 1500 | 12.5×25 | I6 | 0.027 | 0.089 | 2230 | 12.5×35 | I8 | 0.020 | 0.065 | 2880 | — | — | — | — | — | |
| 1800 | 16×20 | J5 | 0.027 | 0.078 | 2530 | 16×25 | J6 | 0.021 | 0.060 | 2930 | — | — | — | — | — | |
| 2200 | 12.5×35 | I8 | 0.020 | 0.065 | 2880 | — | — | — | — | — | — | — | — | — | — | |
| 2700 | 16×25 | J6 | 0.021 | 0.060 | 2930 | — | — | — | — | — | — | — | — | — | — | |

| Rated voltage (V) | Item | 63 | | | | | 100 | | | | |
|-------------------|----------|-------------------|------------------|--------------------|-------|------------------------------------|-------------------|------------------|--------------------|-------|------------------------------------|
| | | Case φD×L (mm) | Casing symbol | Impedance (Ω max.) | | Rated ripple current (mArms) | Case φD×L (mm) | Casing symbol | Impedance (Ω max.) | | Rated ripple current (mArms) |
| | | | | 20°C | -10°C | | | | 20°C | -10°C | |
| 6.8 | — | — | — | — | — | 5×11.5 | E3 | 2.3 | 9.3 | 55 | |
| 15 | 5×11.5 | E3 | 2.3 | 9.3 | 55 | 6.3×11.5 | F3 | 1.2 | 5.0 | 115 | |
| 27 | 6.3×11.5 | F3 | 1.2 | 5.0 | 115 | 8×12 | G3 | 0.63 | 2.8 | 232 | |
| 47 | — | — | — | — | — | 10×12.5 | H3 | 0.43 | 1.8 | 288 | |
| 56 | 8×12 | G3 | 0.63 | 2.8 | 232 | 8×20 | G5 | 0.33 | 1.6 | 362 | |
| 68 | — | — | — | — | — | 10×16 | H4 | 0.31 | 1.5 | 357 | |
| 82 | 8×15 | G4 | 0.45 | 2.1 | 300 | 10×20 | H5 | 0.21 | 0.94 | 466 | |
| 100 | — | — | — | — | — | 10×25 | H6 | 0.20 | 0.84 | 531 | |
| 120 | 10×16 | H4 | 0.31 | 1.5 | 357 | 12.5×20 | I5 | 0.16 | 0.64 | 690 | |
| 180 | 10×20 | H5 | 0.21 | 0.94 | 466 | 12.5×25 | I6 | 0.120 | 0.45 | 784 | |
| 220 | 10×25 | H6 | 0.20 | 0.84 | 531 | 16×20 | J5 | 0.091 | 0.38 | 1040 | |
| 270 | 12.5×20 | I5 | 0.16 | 0.64 | 690 | 16×25 | J6 | 0.073 | 0.27 | 1250 | |
| 330 | 12.5×25 | I6 | 0.12 | 0.45 | 784 | — | — | — | — | — | |
| 390 | 16×20 | J5 | 0.091 | 0.38 | 1040 | — | — | — | — | — | |
| 470 | 16×20 | J5 | 0.091 | 0.38 | 1040 | — | — | — | — | — | |
| 560 | 16×25 | J6 | 0.073 | 0.27 | 1250 | — | — | — | — | — | |

(Note) Rated ripple current : 105°C, 100kHz ; Impedance : 100kHz

105°C Use, Miniature, Long Life, Extra Low Impedance Capacitors

| | | | |
|-----------|---------------|------------------|-----------------------|
| GREEN CAP | Low Impedance | 105°C 10000hours | Anti-cleaning solvent |
|-----------|---------------|------------------|-----------------------|

- Long life than RJF series.
- Guarantees 10000 hours at 105°C.
($\phi 5$: 5000 hours, $\phi 6.3$: 6000 hours, $\phi 8$: 8000 hours)

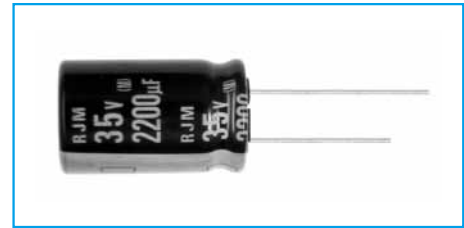
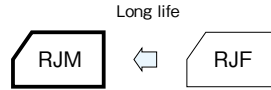

Marking color : White print on a black sleeve

Specifications

| Item | Performance | | | | | | | | | | | | | | | | | | | | |
|---|--|--|------|------|------|------|----|----|------------------------|---------------|------|------|------|------|------|---------------|---|---|---|---|---|
| Category temperature range (°C) | -40 to +105 | | | | | | | | | | | | | | | | | | | | |
| Tolerance at rated capacitance (%) | ±20 (20°C, 120Hz) | | | | | | | | | | | | | | | | | | | | |
| Leakage current (µA) | Less than 0.01CV or 3 whichever is larger (after 2 minutes) C : Rated capacitance (µF), V : Rated voltage (V) (20°C) | | | | | | | | | | | | | | | | | | | | |
| Tangent of loss angle (tanδ) | <table border="1"> <tr> <td>Rated voltage (V)</td> <td>6.3</td> <td>10</td> <td>16</td> <td>25</td> <td>35</td> <td>50</td> </tr> <tr> <td>tanδ (max.)</td> <td>0.22</td> <td>0.19</td> <td>0.16</td> <td>0.14</td> <td>0.12</td> <td>0.10</td> </tr> </table> | Rated voltage (V) | 6.3 | 10 | 16 | 25 | 35 | 50 | tanδ (max.) | 0.22 | 0.19 | 0.16 | 0.14 | 0.12 | 0.10 | | | | | | |
| | Rated voltage (V) | 6.3 | 10 | 16 | 25 | 35 | 50 | | | | | | | | | | | | | | |
| tanδ (max.) | 0.22 | 0.19 | 0.16 | 0.14 | 0.12 | 0.10 | | | | | | | | | | | | | | | |
| 0.02 is added to every 1000µF increase over 1000µF. (20°C, 120Hz) | | | | | | | | | | | | | | | | | | | | | |
| Characteristics at high and low temperature | <table border="1"> <tr> <td>Rated voltage (V)</td> <td>6.3</td> <td>10</td> <td>16</td> <td>25</td> <td>35</td> <td>50</td> </tr> <tr> <td rowspan="2">Impedance ratio (max.)</td> <td>Z-25°C/Z+20°C</td> <td>2</td> <td>2</td> <td>2</td> <td>2</td> <td>2</td> </tr> <tr> <td>Z-40°C/Z+20°C</td> <td>3</td> <td>3</td> <td>3</td> <td>3</td> <td>3</td> </tr> </table> | Rated voltage (V) | 6.3 | 10 | 16 | 25 | 35 | 50 | Impedance ratio (max.) | Z-25°C/Z+20°C | 2 | 2 | 2 | 2 | 2 | Z-40°C/Z+20°C | 3 | 3 | 3 | 3 | 3 |
| | Rated voltage (V) | 6.3 | 10 | 16 | 25 | 35 | 50 | | | | | | | | | | | | | | |
| Impedance ratio (max.) | Z-25°C/Z+20°C | 2 | 2 | 2 | 2 | 2 | | | | | | | | | | | | | | | |
| | Z-40°C/Z+20°C | 3 | 3 | 3 | 3 | 3 | | | | | | | | | | | | | | | |
| (120Hz) | | | | | | | | | | | | | | | | | | | | | |
| Endurance (105°C) (Applied ripple current) | Test time | <ul style="list-style-type: none"> $\phi 5$: 5000 hours $\phi 6.3$: 6000 hours $\phi 8$: 8000 hours $\phi 10$ or more : 10000 hours | | | | | | | | | | | | | | | | | | | |
| | Leakage current | The initial specified value or less | | | | | | | | | | | | | | | | | | | |
| | Percentage of capacitance change | Within ±25% of initial value ($\phi 6.3$ or less: ±30%) | | | | | | | | | | | | | | | | | | | |
| | Tangent of the loss angle | 200% or less of the initial specified value ($\phi 6.3$ or less: 300%) | | | | | | | | | | | | | | | | | | | |
| Shelf life (105°C) | Test time | 1000 hours | | | | | | | | | | | | | | | | | | | |
| | Leakage current | The initial specified value or less | | | | | | | | | | | | | | | | | | | |
| | Percentage of capacitance change | Within ±25% of initial value ($\phi 6.3$ or less: ±30%) | | | | | | | | | | | | | | | | | | | |
| | Tangent of the loss angle | 200% or less of the initial specified value ($\phi 6.3$ or less: 300%) | | | | | | | | | | | | | | | | | | | |
| Voltage application treatment | | | | | | | | | | | | | | | | | | | | | |
| Applicable standards | JIS C5101-1, -4 1998 (IEC 60384-1 1992, -4 1985) | | | | | | | | | | | | | | | | | | | | |

Outline Drawing

Unit : mm

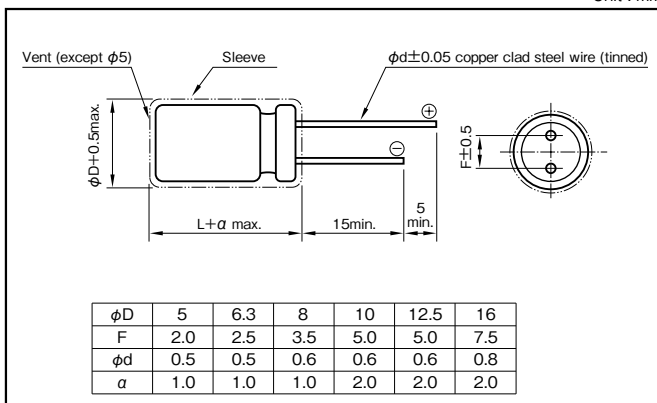

Coefficient of Frequency for Rated Ripple Current

| Rated capacitance (µF) | Frequency (Hz) | | | |
|------------------------|----------------|------|------|------|
| | 120 | 1k | 10k | 100k |
| 27 to 33 | 0.42 | 0.70 | 0.90 | 1 |
| 47 to 270 | 0.50 | 0.73 | 0.92 | 1 |
| 330 to 680 | 0.55 | 0.77 | 0.94 | 1 |
| 820 to 1800 | 0.60 | 0.80 | 0.96 | 1 |
| 2200 to 8200 | 0.70 | 0.85 | 0.98 | 1 |

Part numbering system (example : 10V1000µF)

| | | | | | | | | |
|-------------|---|----------------------|---|--------------------------|------------------------------|---------------|---|-----------------------|
| RJM | — | 10 | V | 102 | M | G4 | # | □ |
| Series code | | Rated voltage symbol | | Rated capacitance symbol | Capacitance tolerance symbol | Casing symbol | | Taping/Forming symbol |

Standard Ratings

| Rated voltage(V) Rated capacitance (μF) | Item | 6.3 | | | | | 10 | | | | | 16 | | | | |
|--|----------|--------------------|---------------|-------------------|-------|-------------------------------|--------------------|---------------|-------------------|-------|-------------------------------|--------------------|---------------|-------------------|-------|-------------------------------|
| | | Case φ DxL (mm) | Casing symbol | Impedance (Ωmax.) | | Rated ripple current (mA rms) | Case φ DxL (mm) | Casing symbol | Impedance (Ωmax.) | | Rated ripple current (mA rms) | Case φ DxL (mm) | Casing symbol | Impedance (Ωmax.) | | Rated ripple current (mA rms) |
| | | | | 20°C | -10°C | | | | 20°C | -10°C | | | | 20°C | -10°C | |
| 82 | — | — | — | — | — | — | — | — | — | — | 5×11.5 | E3 | 0.22 | 0.80 | 345 | |
| 100 | — | — | — | — | — | 5×11.5 | E3 | 0.22 | 0.80 | 345 | 5×11.5 | E3 | 0.22 | 0.80 | 345 | |
| 120 | — | — | — | — | — | 5×11.5 | E3 | 0.22 | 0.80 | 345 | — | — | — | — | — | |
| 150 | 5×11.5 | E3 | 0.22 | 0.80 | 345 | 5×11.5 | E3 | 0.22 | 0.80 | 345 | — | — | — | — | — | |
| 180 | — | — | — | — | — | — | — | — | — | — | 6.3×11.5 | F3 | 0.094 | 0.35 | 540 | |
| 220 | 5×11.5 | E3 | 0.22 | 0.80 | 345 | 6.3×11.5 | F3 | 0.094 | 0.35 | 540 | 6.3×11.5 | F3 | 0.094 | 0.35 | 540 | |
| 270 | — | — | — | — | — | 6.3×11.5 | F3 | 0.094 | 0.35 | 540 | — | — | — | — | — | |
| 330 | 6.3×11.5 | F3 | 0.094 | 0.35 | 540 | 6.3×11.5 | F3 | 0.094 | 0.35 | 540 | — | — | — | — | — | |
| 470 | 6.3×11.5 | F3 | 0.094 | 0.35 | 540 | — | — | — | — | — | 8×12 | G3 | 0.056 | 0.19 | 945 | |
| 680 | — | — | — | — | — | 8×12 | G3 | 0.056 | 0.19 | 945 | 8×15 | G4 | 0.045 | 0.15 | 1250 | |
| 820 | 8×12 | G3 | 0.056 | 0.19 | 945 | — | — | — | — | — | 10×12.5 | H3 | 0.039 | 0.14 | 1560 | |
| 1000 | — | — | — | — | — | 8×15 | G4 | 0.045 | 0.15 | 1250 | 8×20 | G5 | 0.029 | 0.11 | 1500 | |
| 1200 | — | — | — | — | — | 10×12.5 | H3 | 0.039 | 0.14 | 1560 | 10×16 | H4 | 0.028 | 0.10 | 2000 | |
| 1500 | 8×15 | G4 | 0.045 | 0.15 | 1250 | — | — | — | — | — | — | — | — | — | — | |
| 1800 | 10×16 | H4 | 0.028 | 0.10 | 2000 | 8×20 | G5 | 0.029 | 0.11 | 1500 | 10×20 | H5 | 0.020 | 0.060 | 2500 | |
| 2200 | 10×20 | H5 | 0.020 | 0.060 | 2500 | 10×16 | H4 | 0.028 | 0.10 | 2000 | 10×20 | H5 | 0.020 | 0.060 | 2500 | |
| 2700 | 10×25 | H6 | 0.017 | 0.051 | 2900 | 10×20 | H5 | 0.020 | 0.060 | 2500 | 10×25 | H6 | 0.017 | 0.051 | 2900 | |
| 3300 | — | — | — | — | — | 10×25 | H6 | 0.017 | 0.051 | 2900 | 10×25 | H6 | 0.017 | 0.051 | 2900 | |
| 3900 | 12.5×20 | I5 | 0.017 | 0.043 | 2600 | 12.5×20 | I5 | 0.017 | 0.043 | 2600 | 12.5×20 | I5 | 0.017 | 0.043 | 2600 | |
| 4700 | 12.5×25 | I6 | 0.015 | 0.038 | 3200 | 12.5×25 | I6 | 0.015 | 0.038 | 3200 | 12.5×25 | I6 | 0.015 | 0.038 | 3200 | |
| 5600 | 12.5×30 | I7 | 0.013 | 0.033 | 3450 | 12.5×30 | I7 | 0.013 | 0.033 | 3450 | 12.5×30 | I7 | 0.013 | 0.033 | 3450 | |
| 6800 | 12.5×35 | I8 | 0.012 | 0.031 | 3610 | 12.5×35 | I8 | 0.012 | 0.031 | 3610 | 12.5×35 | I8 | 0.012 | 0.031 | 3610 | |
| 8200 | 16×20 | J5 | 0.015 | 0.038 | 3575 | 16×20 | J5 | 0.015 | 0.038 | 3575 | 16×20 | J5 | 0.015 | 0.038 | 3575 | |
| | 16×25 | J6 | 0.013 | 0.035 | 3810 | 16×25 | J6 | 0.013 | 0.035 | 3810 | 16×25 | J6 | 0.013 | 0.035 | 3810 | |

| Rated voltage(V) Rated capacitance (μF) | Item | 25 | | | | | 35 | | | | | 50 | | | | |
|--|----------|--------------------|---------------|-------------------|-------|-------------------------------|--------------------|---------------|-------------------|-------|-------------------------------|--------------------|---------------|-------------------|-------|-------------------------------|
| | | Case φ DxL (mm) | Casing symbol | Impedance (Ωmax.) | | Rated ripple current (mA rms) | Case φ DxL (mm) | Casing symbol | Impedance (Ωmax.) | | Rated ripple current (mA rms) | Case φ DxL (mm) | Casing symbol | Impedance (Ωmax.) | | Rated ripple current (mA rms) |
| | | | | 20°C | -10°C | | | | 20°C | -10°C | | | | 20°C | -10°C | |
| 27 | — | — | — | — | — | — | — | — | — | — | 5×11.5 | E3 | 0.34 | 1.18 | 238 | |
| 39 | 5×11.5 | E3 | 0.22 | 0.80 | 345 | 5×11.5 | E3 | 0.22 | 0.80 | 345 | 6.3×11.5 | F3 | 0.14 | 0.50 | 385 | |
| 47 | — | — | — | — | — | 5×11.5 | E3 | 0.22 | 0.80 | 345 | — | — | — | — | — | |
| 56 | 5×11.5 | E3 | 0.22 | 0.80 | 345 | — | — | — | — | — | 6.3×11.5 | F3 | 0.14 | 0.50 | 385 | |
| 68 | 5×11.5 | E3 | 0.22 | 0.80 | 345 | — | — | — | — | — | — | — | — | — | — | |
| 82 | 5×11.5 | E3 | 0.22 | 0.80 | 345 | 6.3×11.5 | F3 | 0.094 | 0.35 | 540 | — | — | — | — | — | |
| 100 | 6.3×11.5 | F3 | 0.094 | 0.35 | 540 | 6.3×11.5 | F3 | 0.094 | 0.35 | 540 | 8×12 | G3 | 0.074 | 0.22 | 724 | |
| 120 | 6.3×11.5 | F3 | 0.094 | 0.35 | 540 | — | — | — | — | — | 8×15 | G4 | 0.061 | 0.18 | 950 | |
| 150 | 6.3×11.5 | F3 | 0.094 | 0.35 | 540 | — | — | — | — | — | 10×12.5 | H3 | 0.061 | 0.18 | 1250 | |
| 180 | — | — | — | — | — | — | — | — | — | — | 8×20 | G5 | 0.046 | 0.14 | 1190 | |
| 220 | — | — | — | — | — | 8×12 | G3 | 0.056 | 0.19 | 945 | 10×16 | H4 | 0.042 | 0.12 | 1650 | |
| 270 | — | — | — | — | — | 8×15 | G4 | 0.045 | 0.15 | 1250 | 10×20 | H5 | 0.030 | 0.090 | 2060 | |
| 330 | 8×12 | G3 | 0.056 | 0.19 | 945 | 10×12.5 | H3 | 0.039 | 0.14 | 1560 | 10×25 | H6 | 0.028 | 0.084 | 2420 | |
| 390 | 8×15 | G4 | 0.045 | 0.15 | 1250 | 8×20 | G5 | 0.029 | 0.11 | 1500 | — | — | — | — | — | |
| 470 | 10×12.5 | H3 | 0.039 | 0.14 | 1560 | 10×16 | H4 | 0.028 | 0.10 | 2000 | 12.5×20 | I5 | 0.027 | 0.068 | 2300 | |
| 560 | 8×20 | G5 | 0.029 | 0.11 | 1500 | 10×20 | H5 | 0.020 | 0.060 | 2500 | 12.5×25 | I6 | 0.023 | 0.059 | 2800 | |
| 680 | 10×16 | H4 | 0.028 | 0.10 | 2000 | 10×25 | H6 | 0.017 | 0.051 | 2900 | 12.5×30 | I7 | 0.021 | 0.052 | 3360 | |
| 820 | 10×20 | H5 | 0.020 | 0.060 | 2500 | — | — | — | — | — | 12.5×35 | I8 | 0.019 | 0.051 | 3810 | |
| 1000 | 10×25 | H6 | 0.017 | 0.051 | 2900 | 12.5×20 | I5 | 0.017 | 0.043 | 2600 | 16×20 | J5 | 0.023 | 0.059 | 3070 | |
| 1200 | — | — | — | — | — | 12.5×25 | I6 | 0.015 | 0.038 | 3200 | 16×25 | J6 | 0.021 | 0.056 | 3270 | |
| 1500 | 12.5×20 | I5 | 0.017 | 0.043 | 2600 | 12.5×30 | I7 | 0.013 | 0.033 | 3450 | — | — | — | — | — | |
| 1800 | 12.5×25 | I6 | 0.015 | 0.038 | 3200 | 16×20 | J5 | 0.015 | 0.038 | 3575 | — | — | — | — | — | |
| 2200 | 12.5×30 | I7 | 0.013 | 0.033 | 3450 | — | — | — | — | — | — | — | — | — | — | |
| 2700 | 12.5×35 | I8 | 0.012 | 0.031 | 3610 | 16×25 | J6 | 0.013 | 0.035 | 3810 | — | — | — | — | — | |
| 3300 | 16×25 | J6 | 0.013 | 0.035 | 3810 | — | — | — | — | — | — | — | — | — | — | |

(Note) Rated ripple current : 105°C , 100kHz ; Impedance : 100kHz

NOTE : Design, Specifications are subject to change without notice.
It is recommended that you shall obtain technical specifications from ELNA to ensure that the component is suitable for your use.

105°C Use, miniature, Hi-Reliability, Low ESR Capacitors

| | | | |
|-----------|---------|-----------------|-----------------------|
| GREEN CAP | Low ESR | 105°C 8000hours | Anti-cleaning solvent |
|-----------|---------|-----------------|-----------------------|

- Smaller and higher ripple current than RJB series.
- Guarantees 8000 hours at 105°C.
($\phi 5$ to 6.3 : 2000 hours; $\phi 8$: 3000 hours; $\phi 10$: 5000 hours)

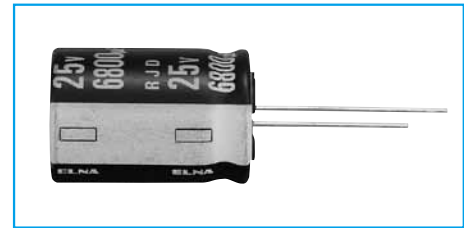
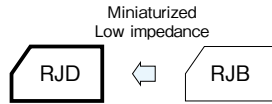

Marking color : White print on a black sleeve

Specifications

| Item | Performance | | | | | | | | | |
|---|--|---|------|------|------|------|------|------|------|------|
| Category temperature range (°C) | -55 to +105 | | | | | | | | | |
| Tolerance at rated capacitance (%) | ±20 (20°C, 120Hz) | | | | | | | | | |
| Leakage current (µA) | Less than 0.01CV or 3 whichever is larger (after 2 minutes) C : Rated capacitance (µF), V : Rated voltage (V) (20°C) | | | | | | | | | |
| Tangent of loss angle (tanδ) | Rated voltage (V) | 6.3 | 10 | 16 | 25 | 35 | 50 | 63 | 80 | 100 |
| | tanδ (max.) | 0.22 | 0.19 | 0.16 | 0.14 | 0.12 | 0.10 | 0.10 | 0.08 | 0.08 |
| 0.02 is added to every 1000µF increase over 1000µF. (20°C, 120Hz) | | | | | | | | | | |
| Characteristics at high and low temperature | Rated voltage (V) | 6.3 | 10 | 16 | 25 | 35 | 50 | 63 | 80 | 100 |
| | Impedance ratio (max.) | Z-55°C/Z+20°C | 3 | 3 | 3 | 3 | 3 | 3 | 3 | 3 |
| (120Hz) | | | | | | | | | | |
| Endurance (105°C) (Applied ripple current) | Test time | $\phi 5$ & 6.3 : 2000 hours $\phi 8$: 3000 hours $\phi 10$: 5000 hours $\phi 12.5$ to $\phi 20$: 8000 hours | | | | | | | | |
| | Leakage current | The initial specified value or less | | | | | | | | |
| | Percentage of capacitance change | Within ±20% of initial value | | | | | | | | |
| | Tangent of the loss angle | 200% or less of the initial specified value | | | | | | | | |
| Shelf life (105°C) | Test time : 1000 hours ; other items are the same as those for the endurance. Voltage application treatment: According to JIS C5101 -1 | | | | | | | | | |
| Applicable standards | JIS C5101-1, -4 1998 (IEC 60384-1 1992, -4 1985) | | | | | | | | | |

Outline Drawing

Unit : mm

Vent (except $\phi 5$)
Sleeve
 $\phi d \pm 0.05$ copper clad steel wire (tinned)

$\phi D \pm 0.5 \text{ max.}$
 $L + a \text{ max.}$
15 min.
5 min.

| | | | | | | | | |
|----------|-----|-----|-----|-----|------|-----|-----|------|
| ϕD | 5 | 6.3 | 8 | 10 | 12.5 | 16 | 18 | 20 |
| F | 2.0 | 2.5 | 3.5 | 5.0 | 5.0 | 7.5 | 7.5 | 10.0 |
| ϕd | 0.5 | 0.5 | 0.6 | 0.6 | 0.6 | 0.8 | 0.8 | 1.0 |
| a | 1.0 | 1.0 | 1.0 | 2.0 | 2.0 | 2.0 | 2.0 | 2.0 |

(Note) Whisker preventive structure is possible for $\phi 8$ or more.

Coefficient of Frequency for Rated Ripple Current

| Rated Capacitance (µF) | Frequency (Hz) | | | | |
|------------------------|----------------|------|------|------|------------|
| | 50 · 60 | 120 | 300 | 1k | 10k · 100k |
| 56 or less | 0.20 | 0.30 | 0.50 | 0.80 | 1 |
| 68 to 330 | 0.55 | 0.65 | 0.75 | 0.85 | 1 |
| 390 to 1000 | 0.70 | 0.75 | 0.80 | 0.90 | 1 |
| 1200 to 18000 | 0.80 | 0.85 | 0.90 | 0.95 | 1 |

Part numbering system (example : 6.3V10000µF)

| | | | | | | | | | |
|-------------|---|----------------------|---|--------------------------|------------------------------|---------------|---|---|-----------------------|
| RJD | — | 6 | V | 103 | M | J7 | # | — | □ |
| Series code | | Rated voltage symbol | | Rated capacitance symbol | Capacitance tolerance symbol | Casing symbol | | | Taping/Forming symbol |

If it is whisker preventive structure, should change “#” into “G”.

Standard Ratings

| Rated voltage(V) Rated capacitance(μF) | Item | 6.3 | | | | 10 | | | | 16 | | | | | | |
|---|----------|-------------------|------------------|--------------|-------|------------------------------------|-------------------|------------------|--------------|-------|------------------------------------|-------------------|------------------|--------------|-------|------------------------------------|
| | | Case φD×L (mm) | Casing symbol | ESR (Ω max.) | | Rated ripple current (mArms) | Case φD×L (mm) | Casing symbol | ESR (Ω max.) | | Rated ripple current (mArms) | Case φD×L (mm) | Casing symbol | ESR (Ω max.) | | Rated ripple current (mArms) |
| | | | | 20°C | -10°C | | | | 20°C | -10°C | | | | 20°C | -10°C | |
| 22 | — | — | — | — | — | — | — | — | — | — | 5×11.5 | E3 | 0.5 | 1.0 | 182 | |
| 33 | — | — | — | — | — | — | — | — | — | — | 5×11.5 | E3 | 0.5 | 1.0 | 182 | |
| 47 | — | — | — | — | — | — | — | — | — | — | 5×11.5 | E3 | 0.5 | 1.0 | 182 | |
| 82 | — | — | — | — | — | — | — | — | — | — | 5×11.5 | E3 | 0.5 | 1.0 | 182 | |
| 100 | — | — | — | — | — | 5×11.5 | E3 | 0.5 | 1.0 | 182 | 6.3×11.5 | F3 | 0.25 | 0.50 | 295 | |
| 150 | 5×11.5 | E3 | 0.50 | 1.0 | 182 | — | — | — | — | — | 6.3×11.5 | F3 | 0.25 | 0.50 | 295 | |
| 180 | — | — | — | — | — | 6.3×11.5 | F3 | 0.25 | 0.50 | 295 | 8×12 | G3 | 0.117 | 0.234 | 567 | |
| 220 | — | — | — | — | — | 6.3×11.5 | F3 | 0.25 | 0.50 | 295 | 8×12 | G3 | 0.117 | 0.234 | 567 | |
| 330 | 6.3×11.5 | F3 | 0.25 | 0.50 | 295 | 8×12 | G3 | 0.117 | 0.234 | 567 | 8×12 | G3 | 0.117 | 0.234 | 567 | |
| 390 | — | — | — | — | — | — | — | — | — | — | 8×12 | G3 | 0.117 | 0.234 | 567 | |
| 470 | 8×12 | G3 | 0.117 | 0.234 | 567 | 8×12 | G3 | 0.117 | 0.234 | 567 | 8×15 | G4 | 0.085 | 0.170 | 733 | |
| | | | | | | | | | | | 10×12.5 | H3 | 0.090 | 0.180 | 764 | |
| 560 | 8×12 | G3 | 0.117 | 0.234 | 567 | 8×12 | G3 | 0.117 | 0.234 | 567 | 8×20 | G5 | 0.065 | 0.130 | 996 | |
| 680 | 8×12 | G3 | 0.117 | 0.234 | 567 | — | — | — | — | — | 8×15 | G4 | 0.085 | 0.170 | 733 | |
| | | | | | | | | | | | 10×12.5 | H3 | 0.090 | 0.180 | 764 | |
| 820 | — | — | — | — | — | 8×15 | G4 | 0.085 | 0.170 | 733 | 8×20 | G5 | 0.065 | 0.130 | 996 | |
| | | | | | | 10×12.5 | H3 | 0.090 | 0.180 | 764 | 10×16 | H4 | 0.068 | 0.136 | 1060 | |
| 1000 | 8×15 | G4 | 0.085 | 0.170 | 733 | 8×20 | G5 | 0.065 | 0.130 | 996 | 10×16 | H4 | 0.068 | 0.136 | 1060 | |
| | 10×12.5 | H3 | 0.090 | 0.180 | 764 | 10×12.5 | H3 | 0.090 | 0.180 | 764 | 10×20 | H5 | 0.052 | 0.104 | 1230 | |
| | | | | | | 10×16 | H4 | 0.068 | 0.136 | 1060 | 10×20 | H5 | 0.052 | 0.104 | 1230 | |
| 1200 | 10×12.5 | H3 | 0.090 | 0.180 | 764 | 8×20 | G5 | 0.065 | 0.130 | 996 | 10×20 | H5 | 0.052 | 0.104 | 1230 | |
| | 10×16 | H4 | 0.068 | 0.136 | 1060 | 10×16 | H4 | 0.068 | 0.136 | 1060 | 10×25 | H6 | 0.045 | 0.090 | 1450 | |
| 1500 | 8×20 | G5 | 0.065 | 0.130 | 996 | 10×20 | H5 | 0.052 | 0.104 | 1230 | 10×25 | H6 | 0.045 | 0.090 | 1450 | |
| | 10×16 | H4 | 0.068 | 0.136 | 1060 | 12.5×15 | I4 | 0.062 | 0.124 | 1210 | 10×30 | H7 | 0.035 | 0.070 | 1830 | |
| 1800 | 12.5×15 | I4 | 0.062 | 0.124 | 1210 | 10×20 | H5 | 0.052 | 0.104 | 1230 | — | — | — | — | — | |
| | | | | | | 10×25 | H6 | 0.045 | 0.090 | 1450 | 10×30 | H7 | 0.035 | 0.070 | 1830 | |
| 2200 | 10×20 | H5 | 0.052 | 0.104 | 1230 | 10×25 | H6 | 0.045 | 0.090 | 1450 | 12.5×20 | I5 | 0.038 | 0.076 | 1700 | |
| | 10×25 | H6 | 0.045 | 0.090 | 1450 | 12.5×20 | I5 | 0.038 | 0.076 | 1700 | 16×16 | J4 | 0.043 | 0.086 | 1700 | |
| 2700 | 10×25 | H6 | 0.045 | 0.090 | 1450 | 10×30 | H7 | 0.035 | 0.070 | 1830 | 12.5×25 | I6 | 0.030 | 0.060 | 1950 | |
| | | | | | | 12.5×20 | I5 | 0.038 | 0.076 | 1700 | 18×16 | K4 | 0.038 | 0.076 | 2010 | |
| 3300 | 10×30 | H7 | 0.035 | 0.070 | 1830 | 12.5×25 | I6 | 0.030 | 0.060 | 1950 | 12.5×30 | I7 | 0.025 | 0.050 | 2330 | |
| | 12.5×20 | I5 | 0.038 | 0.076 | 1700 | 12.5×25 | I6 | 0.030 | 0.060 | 1950 | 16×20 | J5 | 0.029 | 0.058 | 2230 | |
| 3900 | 12.5×25 | I6 | 0.030 | 0.060 | 1950 | 12.5×25 | I6 | 0.030 | 0.060 | 1950 | 12.5×35 | I8 | 0.022 | 0.044 | 2620 | |
| | | | | | | 18×16 | K4 | 0.038 | 0.076 | 2010 | 16×20 | J5 | 0.029 | 0.058 | 2230 | |
| 4700 | 12.5×25 | I6 | 0.030 | 0.060 | 1950 | 12.5×30 | I7 | 0.025 | 0.050 | 2330 | 12.5×40 | I9 | 0.017 | 0.034 | 3160 | |
| | 18×16 | K4 | 0.038 | 0.076 | 2010 | 16×20 | J5 | 0.029 | 0.058 | 2230 | 16×25 | J6 | 0.022 | 0.044 | 2650 | |
| | | | | | | | | | | | 18×20 | K5 | 0.028 | 0.056 | 2500 | |
| 5600 | 12.5×30 | I7 | 0.025 | 0.050 | 2330 | 12.5×35 | I8 | 0.022 | 0.044 | 2620 | 16×25 | J6 | 0.022 | 0.044 | 2650 | |
| | 16×20 | J5 | 0.029 | 0.058 | 2230 | 12.5×35 | I8 | 0.022 | 0.044 | 2620 | 16×31.5 | J7 | 0.018 | 0.036 | 3210 | |
| 6800 | 12.5×35 | I8 | 0.022 | 0.044 | 2620 | 12.5×40 | I9 | 0.017 | 0.034 | 3160 | 18×25 | K6 | 0.020 | 0.040 | 3000 | |
| | | | | | | 16×25 | J6 | 0.022 | 0.044 | 2650 | 18×25 | K6 | 0.020 | 0.040 | 3000 | |
| 8200 | 12.5×40 | I9 | 0.017 | 0.034 | 3160 | 16×31.5 | J7 | 0.018 | 0.036 | 3210 | 18×35.5 | K8 | 0.015 | 0.030 | 3960 | |
| | 16×25 | J6 | 0.022 | 0.044 | 2650 | 18×25 | K6 | 0.020 | 0.040 | 3000 | 18×40 | K9 | 0.014 | 0.028 | 4300 | |
| | 18×20 | K5 | 0.028 | 0.056 | 2500 | 16×40 | J9 | 0.015 | 0.030 | 3880 | 18×40 | K9 | 0.014 | 0.028 | 4300 | |
| 10000 | 16×31.5 | J7 | 0.018 | 0.036 | 3210 | 18×35.5 | K8 | 0.015 | 0.030 | 3960 | — | — | — | — | — | |
| | 18×25 | K6 | 0.020 | 0.040 | 3000 | — | — | — | — | — | — | — | — | — | — | |
| 12000 | 18×25 | K6 | 0.020 | 0.040 | 3000 | — | — | — | — | — | — | — | — | — | — | |
| 15000 | 18×35.5 | K8 | 0.015 | 0.030 | 3960 | 18×40 | K9 | 0.014 | 0.028 | 4300 | — | — | — | — | — | |
| 18000 | 18×40 | K9 | 0.014 | 0.028 | 4300 | — | — | — | — | — | — | — | — | — | — | |

(Note) Rated ripple current : 105°C , 100kHz ; ESR : 100kHz

Standard Ratings

| Rated voltage(V) | Item | 25 | | | | | 35 | | | | | 50 | | | | | | | | | | | | | | | | | | |
|------------------|------|-----------|---------------|--------------|-------|---|------|---------------|--------------|-----------|---|------|---------------|--------------|-------|---|------|-------|------|------|------|------|------|------|------|------|------|------|------|-------|
| | | Case | Casing symbol | ESR (Ω max.) | | Rated ripple current (mA _{rms}) | Case | Casing symbol | ESR (Ω max.) | | Rated ripple current (mA _{rms}) | Case | Casing symbol | ESR (Ω max.) | | Rated ripple current (mA _{rms}) | | | | | | | | | | | | | | |
| | | | | 20°C | -10°C | | | | 20°C | -10°C | | | | 20°C | -10°C | | 20°C | -10°C | | | | | | | | | | | | |
| | | φD×L (mm) | | | | φD×L (mm) | | | | φD×L (mm) | | | | | | | | | | | | | | | | | | | | |
| 10 | 22 | 27 | 33 | 47 | 56 | 82 | 100 | 150 | 180 | 220 | 270 | 330 | 390 | 470 | 560 | 680 | 820 | 1000 | 1200 | 1500 | 1800 | 2200 | 2700 | 3300 | 3900 | 4700 | 5600 | 6800 | 8200 | 10000 |

| Rated voltage(V) | Item | 63 | | | | | 80 | | | | | 100 | | | | | | | | |
|------------------|------|-----------|---------------|--------------|-------|---|------|---------------|--------------|-----------|---|------|---------------|--------------|-------|---|------|-------|------|------|
| | | Case | Casing symbol | ESR (Ω max.) | | Rated ripple current (mA _{rms}) | Case | Casing symbol | ESR (Ω max.) | | Rated ripple current (mA _{rms}) | Case | Casing symbol | ESR (Ω max.) | | Rated ripple current (mA _{rms}) | | | | |
| | | | | 20°C | -10°C | | | | 20°C | -10°C | | | | 20°C | -10°C | | 20°C | -10°C | | |
| | | φD×L (mm) | | | | φD×L (mm) | | | | φD×L (mm) | | | | | | | | | | |
| 10 | 22 | 27 | 33 | 47 | 56 | 82 | 100 | 150 | 180 | 220 | 270 | 330 | 390 | 470 | 560 | 680 | 820 | 1000 | 1500 | 1800 |

(Note) Rated ripple current : 105°C, 100kHz ; ESR : 100kHz

For AirBag

GREEN CAP

105°C
5000hours

Anti-cleaning solvent

For AirBag

- For AirBag application
- High capacitance, low impedance, and good low temperature behavior
- Guarantees 5000 hours at 105°C.

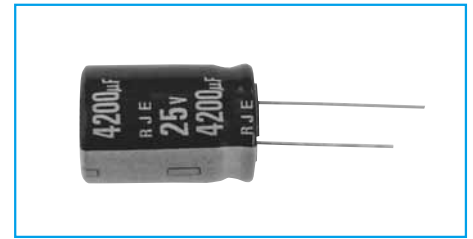

Marking color : White print on a black sleeve

Specifications

| Item | Performance | | |
|---|---|---|------|
| Category temperature range (°C) | -55 to +105 | | |
| Tolerance at rated capacitance (%) | 0 to +30 (20°C,120Hz) | | |
| Leakage current (µA) | Less than 0.01CV (after 2 minutes) C : Rated capacitance (µF) , V : Rated voltage (V) (20°C) | | |
| Tangent of loss angle (tanδ) | Rated voltage (V) | 25 | 35 |
| | tanδ (max.) | 0.20 | 0.16 |
| 0.02 is added to every 1000µF increase over 1000µF (20°C,120Hz) | | | |
| Characteristics at high and low temperature | Rated voltage (V) | 25 | 35 |
| | Impedance ratio (max.) Z-55°C/Z+20°C | 0.20 | 0.16 |
| (120Hz) | | | |
| Endurance (105°C) | Test time | 5000 hours | |
| | Leakage current | The initial specified value or less | |
| | Percentage of capacitance change | Within ±30% of initial value | |
| | Tangent of loss angle | 300% or less of the initial specified value | |
| Shelf life (105°C) | Test time : 1000 hours ; other items are the same as those for the endurance. Voltage application treatment | | |
| Applicable standards | JIS C5101-1, -4 1998 (IEC 60384-1 1992, -4 1985) | | |

Outline Drawing

Unit : mm

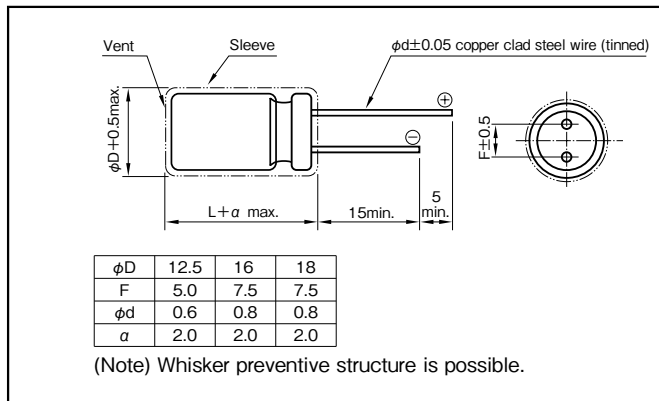

Coefficient of Frequency for Rated Ripple Current

| Frequency (Hz) | 50 · 60 | 120 | 1k | 10k·100k |
|------------------------|---------|------|------|----------|
| Rated capacitance (µF) | | | | |
| 830 to 1100 | 0.70 | 0.75 | 0.90 | 1 |
| 1200 to 11000 | 0.80 | 0.85 | 0.95 | 1 |

Part numbering system (example : 25V420µF)

| | | | | | | | | | |
|-------------|---|----------------------|---|--------------------------|------------------------------|---------------|-----------------|---|------------------------|
| RJE | — | 25 | V | 422 | A | I9 | (#)Q | — | □ |
| Series code | | Rated voltage symbol | | Rated capacitance symbol | Capacitance tolerance symbol | Casing symbol | Optional symbol | | Taping(Forming) symbol |

If it is whisker preventive structure, should change “#” into “G”.

Standard Ratings

| Case size φD×L (mm) | Casing symbol | Rated voltage(V) | | 25 | | | 35 | | | |
|------------------------|------------------|------------------|---------------------|--------------|-------|------------------------------------|---------------------|--------------|-------|------------------------------------|
| | | Item | Capacitance (µF) | ESR / 100kHz | | Rated ripple current (mArms) | Capacitance (µF) | ESR / 100kHz | | Rated ripple current (mArms) |
| | | | | 20°C | -40°C | | | 20°C | -40°C | |
| 12.5×15 | I4 | 1100 | 0.174 | 0.52 | 1210 | 830 | 0.174 | 0.52 | 1210 | |
| 12.5×20 | I5 | 1800 | 0.107 | 0.27 | 1670 | 1300 | 0.107 | 0.27 | 1670 | |
| 12.5×25 | I6 | 2400 | 0.084 | 0.21 | 1950 | 1600 | 0.084 | 0.21 | 1950 | |
| 12.5×30 | I7 | 3200 | 0.070 | 0.18 | 2330 | 2200 | 0.070 | 0.18 | 2330 | |
| 12.5×35 | I8 | 3700 | 0.062 | 0.16 | 2620 | 2500 | 0.062 | 0.16 | 2620 | |
| 12.5×40 | I9 | 4200 | 0.048 | 0.12 | 3160 | 2900 | 0.048 | 0.12 | 3160 | |
| 16×16 | J4 | 2100 | 0.121 | 0.36 | 1700 | 1500 | 0.121 | 0.36 | 1700 | |
| 16×20 | J5 | 3100 | 0.082 | 0.21 | 2230 | 2100 | 0.082 | 0.21 | 2230 | |
| 16×25 | J6 | 4300 | 0.062 | 0.16 | 2650 | 3000 | 0.062 | 0.16 | 2650 | |
| 16×31.5 | J7 | 5800 | 0.051 | 0.13 | 3210 | 4000 | 0.051 | 0.13 | 3210 | |
| 16×35.5 | J8 | 6800 | 0.045 | 0.11 | 3570 | 4600 | 0.045 | 0.11 | 3570 | |
| 16×40 | J9 | 7800 | 0.042 | 0.11 | 3880 | 5300 | 0.042 | 0.11 | 3880 | |
| 18×16 | K4 | 3000 | 0.107 | 0.32 | 2010 | 2100 | 0.107 | 0.32 | 2010 | |
| 18×20 | K5 | 4300 | 0.079 | 0.20 | 2500 | 3000 | 0.079 | 0.20 | 2500 | |
| 18×25 | K6 | 6000 | 0.056 | 0.14 | 3000 | 4200 | 0.056 | 0.14 | 3000 | |
| 18×31.5 | K7 | 8000 | 0.045 | 0.11 | 3660 | 5600 | 0.045 | 0.11 | 3660 | |
| 18×35.5 | K8 | 9300 | 0.042 | 0.11 | 3960 | 6500 | 0.042 | 0.11 | 3960 | |
| 18×40 | K9 | 11000 | 0.040 | 0.10 | 4300 | 7400 | 0.040 | 0.10 | 4300 | |

(Note) Rated ripple current : 105°C, 100kHz

NOTE : Design, Specifications are subject to change without notice.
It is recommended that you shall obtain technical specifications from ELNA to ensure that the component is suitable for your use.

105°C Use, Miniature, High-Ripple, Long Life Capacitors

GREEN CAP 105°C 5000hours

- Higher ripple current.
- Guarantees 4000 to 5000 hours at 105°C.
- Best-suited to electronic ballast.

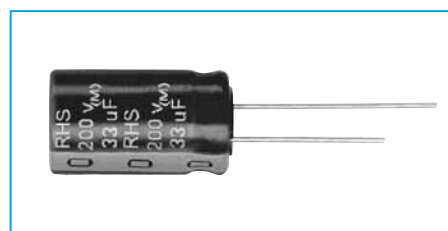
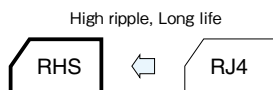

Marking color : White print on a black sleeve

Specifications

| Item | Performance | | | | | | | | | | |
|---|---|-------------------|--|-----------------|-------------------------------------|-----------------------|--------------------------------------|-----------------------|---|---|---|
| Category temperature range (°C) | -40 to +105 (-25 to +105 at 350V or more) | | | | | | | | | | |
| Rated Voltage (V) | 160 to 450 | | | | | | | | | | |
| Tolerance at rated capacitance (%) | ±20 (20°C,120Hz) | | | | | | | | | | |
| Leakage current (µA) | CV≥1000 : Less than 0.06CV+40 (after 1 minutes) CV<1000 : Less than 0.03CV+70 (after 1 minutes) C : Rated capacitance (µF), V : Rated voltage (V) (20°C) | | | | | | | | | | |
| Tangent of loss angle (tanδ) | <table border="1"> <tr> <td>Rated voltage (V)</td> <td>160 to 250</td> <td>350 to 400</td> <td>450</td> </tr> <tr> <td>Tangent of loss angle</td> <td>0.12</td> <td>0.15</td> <td>0.20</td> </tr> </table> <p>(20°C,120Hz)</p> | Rated voltage (V) | 160 to 250 | 350 to 400 | 450 | Tangent of loss angle | 0.12 | 0.15 | 0.20 | | |
| Rated voltage (V) | 160 to 250 | 350 to 400 | 450 | | | | | | | | |
| Tangent of loss angle | 0.12 | 0.15 | 0.20 | | | | | | | | |
| Characteristics at high and low temperature | <table border="1"> <tr> <td>Rated voltage (V)</td> <td>160 to 250</td> <td>350 to 450</td> </tr> <tr> <td rowspan="2">Impedance ratio</td> <td>Z-25°C/Z+20°C</td> <td>3</td> <td>6</td> </tr> <tr> <td>Z-40°C/Z+20°C</td> <td>4</td> <td>-</td> </tr> </table> <p>(120Hz)</p> | Rated voltage (V) | 160 to 250 | 350 to 450 | Impedance ratio | Z-25°C/Z+20°C | 3 | 6 | Z-40°C/Z+20°C | 4 | - |
| Rated voltage (V) | 160 to 250 | 350 to 450 | | | | | | | | | |
| Impedance ratio | Z-25°C/Z+20°C | 3 | 6 | | | | | | | | |
| | Z-40°C/Z+20°C | 4 | - | | | | | | | | |
| Endurance (105°C) (Applied ripple current) | <table border="1"> <tr> <td>Test time</td> <td>φ10 : 4000 hours φ12.5 to 18 : 5000 hours</td> </tr> <tr> <td>Leakage current</td> <td>The initial specified value or less</td> </tr> <tr> <td>Capacitance change</td> <td>Within -20% to +20% of initial value</td> </tr> <tr> <td>Tangent of loss angle</td> <td>300% or less of the initial specified value</td> </tr> </table> | Test time | φ10 : 4000 hours φ12.5 to 18 : 5000 hours | Leakage current | The initial specified value or less | Capacitance change | Within -20% to +20% of initial value | Tangent of loss angle | 300% or less of the initial specified value | | |
| Test time | φ10 : 4000 hours φ12.5 to 18 : 5000 hours | | | | | | | | | | |
| Leakage current | The initial specified value or less | | | | | | | | | | |
| Capacitance change | Within -20% to +20% of initial value | | | | | | | | | | |
| Tangent of loss angle | 300% or less of the initial specified value | | | | | | | | | | |
| Shelf life (105°C) | <table border="1"> <tr> <td>Test time</td> <td>1000 hours</td> </tr> <tr> <td>Leakage current</td> <td>The initial specified value or less</td> </tr> <tr> <td>Capacitance change</td> <td>Within -20% to +20% of initial value</td> </tr> <tr> <td>Tangent of loss angle</td> <td>200% or less of the initial specified value</td> </tr> </table> <p>Voltage application treatment</p> | Test time | 1000 hours | Leakage current | The initial specified value or less | Capacitance change | Within -20% to +20% of initial value | Tangent of loss angle | 200% or less of the initial specified value | | |
| Test time | 1000 hours | | | | | | | | | | |
| Leakage current | The initial specified value or less | | | | | | | | | | |
| Capacitance change | Within -20% to +20% of initial value | | | | | | | | | | |
| Tangent of loss angle | 200% or less of the initial specified value | | | | | | | | | | |
| Applicable Standards | JIS C 5101-01, -04 1998 (IEC 60384-1 1992, 60384-4 1985) | | | | | | | | | | |

Outline Drawing

Unit : mm

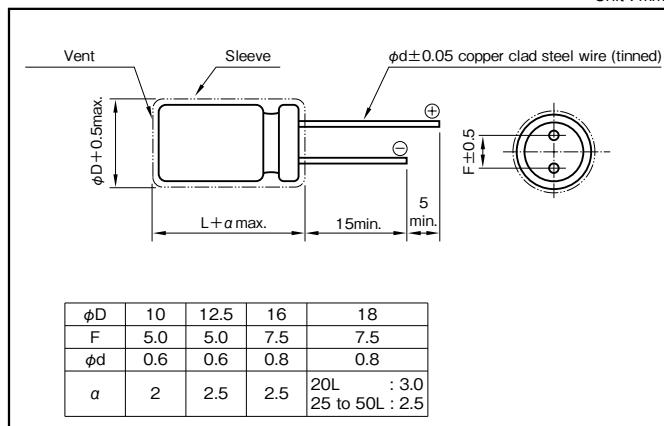

Coefficient of Frequency for Rated Ripple Current

| Rated voltage (V) | Rated capacitance (µF) | Frequency (Hz) | | | | |
|-------------------|------------------------|----------------|-----|------|------|------|
| | | 50 · 60 | 120 | 1k | 10k | 100k |
| 160 to 250 | 4.7 to 10 | 0.80 | 1 | 1.75 | 2.00 | 2.50 |
| | 12 to 47 | 0.80 | 1 | 1.60 | 1.80 | 2.00 |
| | 56 to 560 | 0.80 | 1 | 1.30 | 1.40 | 1.40 |
| 350 to 450 | 1 to 10 | 0.80 | 1 | 1.75 | 2.00 | 2.50 |
| | 12 to 18 | 0.80 | 1 | 1.60 | 1.80 | 2.00 |
| | 22 to 220 | 0.80 | 1 | 1.40 | 1.50 | 1.50 |

Part numbering system (example : 400V10µF)

| | | | | | | | | |
|-------------|---|----------------------|--------------------------|------------------------------|---------------|-----------------|---|------------------------|
| RHS | — | 400 V | 100 | M | I5 # | B | — | □ |
| Series code | | Rated voltage symbol | Rated capacitance symbol | Capacitance tolerance symbol | Casing symbol | Optional symbol | | Taping(Forming) symbol |

Standard Ratings

| Rated voltage (V) | | | 160 | | | 200 | | | 250 | | | 350 | | |
|-------------------|------------------|------|------------------------------|-----------------|------------------------------------|------------------------------|-----------------|------------------------------------|------------------------------|-----------------|------------------------------------|------------------------------|-----------------|------------------------------------|
| Case φD×L(mm) | Casing symbol | Item | Rated capacitance (μF) | ESR (Ω max.) | Rated ripple current (mArms) | Rated capacitance (μF) | ESR (Ω max.) | Rated ripple current (mArms) | Rated capacitance (μF) | ESR (Ω max.) | Rated ripple current (mArms) | Rated capacitance (μF) | ESR (Ω max.) | Rated ripple current (mArms) |
| 10×12.5 | H3 | | 27 | 5.9 | 145 | 4.7 | 34 | 60 | 4.7 | 34 | 60 | 3.3 | 60 | 50 |
| | | | | | | 18 | 8.8 | 105 | 10 | 16 | 82 | 4.7 | 42 | 55 |
| 10×16 | H4 | | 10 | 16 | 96 | 10 | 16 | 95 | 10 | 16 | 90 | 8.2 | 24 | 85 |
| | | | 39 | 4.1 | 185 | 22 | 7.2 | 110 | 4.7 | 42 | 65 | 12 | 17 | 120 |
| 10×20 | H5 | | 22 | 7.2 | 145 | 22 | 7.2 | 145 | 10 | 16 | 105 | 15 | 13 | 145 |
| | | | 56 | 2.8 | 270 | 33 | 4.8 | 170 | 22 | 7.2 | 150 | | | |
| 10×25 | H6 | | 68 | 2.3 | 290 | 47 | 3.4 | 245 | 39 | 4.1 | 240 | 22 | 9.0 | 175 |
| 10×30 | H7 | | 100 | 1.6 | 315 | 68 | 2.3 | 350 | 47 | 3.4 | 270 | 27 | 7.4 | 210 |
| 12.5×20 | I5 | | 33 | 4.8 | 190 | 33 | 4.8 | 190 | 47 | 3.4 | 260 | 10 | 20 | 120 |
| | | | 82 | 1.9 | 270 | 56 | 2.8 | 240 | 27 | 7.4 | 200 | | | |
| 12.5×25 | I6 | | 47 | 3.4 | 280 | 47 | 3.4 | 280 | 22 | 7.2 | 180 | 22 | 9.0 | 180 |
| | | | 100 | 1.6 | 325 | 82 | 1.9 | 320 | 33 | 4.8 | 250 | 39 | 5.1 | 225 |
| 12.5×30 | I7 | | 150 | 1.1 | 435 | 120 | 1.3 | 420 | 82 | 1.9 | 420 | 56 | 3.6 | 290 |
| 12.5×40 | I9 | | 220 | 0.7 | 500 | — | — | — | 120 | 1.3 | 580 | 68 | 2.9 | 370 |
| 16×20 | J5 | | 47 | 3.4 | 280 | 47 | 3.4 | 280 | 33 | 4.8 | 250 | 22 | 9.0 | 180 |
| | | | 120 | 1.3 | 375 | 100 | 1.6 | 370 | 68 | 2.3 | 275 | 47 | 4.2 | 270 |
| 16×25 | J6 | | 180 | 0.9 | 505 | 150 | 1.1 | 500 | 47 | 3.4 | 300 | 33 | 6.0 | 210 |
| | | | | | | 120 | 1.3 | 405 | 68 | 2.9 | 365 | | | |
| 16×31.5 | J7 | | 270 | 0.6 | 685 | 100 | 1.6 | 410 | 100 | 1.6 | 410 | 82 | 2.4 | 445 |
| | | | | | | 220 | 0.7 | 665 | 150 | 1.1 | 510 | | | |
| 16×35.5 | J8 | | 330 | 0.5 | 800 | — | — | — | 180 | 0.9 | 590 | 47 | 4.2 | 300 |
| 16×40 | J9 | | 390 | 0.4 | 915 | 270 | 0.6 | 820 | 220 | 0.7 | 685 | 120 | 1.7 | 600 |
| | | | | | | 100 | 1.6 | 380 | 47 | 3.4 | 300 | 56 | 3.6 | 325 |
| 18×20 | K5 | | 180 | 0.9 | 490 | 120 | 1.3 | 430 | 100 | 1.6 | 360 | 82 | 2.4 | 430 |
| | | | 270 | 0.6 | 660 | 100 | 1.6 | 410 | 100 | 1.6 | 410 | 150 | 1.1 | 485 |
| 18×25 | K6 | | | | | 180 | 0.9 | 580 | 150 | 1.1 | 485 | 47 | 4.2 | 300 |
| | | | | | | 100 | 1.6 | 410 | 150 | 1.1 | 485 | 100 | 2.0 | 520 |
| 18×31.5 | K7 | | 330 | 0.5 | 810 | 270 | 0.6 | 790 | 180 | 0.9 | 590 | 47 | 4.2 | 300 |
| 18×35.5 | K8 | | 220 | 0.7 | 630 | — | — | — | 220 | 0.7 | 690 | 120 | 1.7 | 600 |
| | | | 390 | 0.4 | 925 | | | | | | | | | |
| 18×40 | K9 | | 470 | 0.3 | 1050 | 330 | 0.5 | 970 | 270 | 0.6 | 810 | 150 | 1.3 | 715 |
| 18×45 | KA | | 560 | 0.3 | 1230 | 390 | 0.4 | 1100 | 330 | 0.5 | 945 | 180 | 1.1 | 730 |
| 18×50 | KB | | — | — | — | 470 | 0.3 | 1200 | — | — | — | 220 | 0.9 | 960 |

| Rated voltage (V) | | | 400 | | | 450 | | |
|-------------------|------------------|------|------------------------------|-----------------|------------------------------------|------------------------------|-----------------|------------------------------------|
| Case φD×L(mm) | Casing symbol | Item | Rated capacitance (μF) | ESR (Ω max.) | Rated ripple current (mArms) | Rated capacitance (μF) | ESR (Ω max.) | Rated ripple current (mArms) |
| 10×12.5 | H3 | | 2.2 | 90 | 40 | 1.0 | 265 | 30 |
| | | | 6.8 | 29 | 70 | 5.6 | 47 | 60 |
| 10×16 | H4 | | 3.3 | 60 | 50 | 2.2 | 121 | 45 |
| | | | 10 | 20 | 95 | 8.2 | 32 | 90 |
| 10×20 | H5 | | 4.7 | 42 | 70 | 3.3 | 80 | 65 |
| 10×25 | H6 | | | | | 12 | 22 | 120 |
| | | | 18 | 11 | 160 | 15 | 18 | 150 |
| 10×30 | H7 | | 22 | 9.0 | 200 | 22 | 12 | 190 |
| 12.5×20 | I5 | | 10 | 20 | 120 | 18 | 15 | 170 |
| | | | 22 | 9.0 | 200 | | | |
| 12.5×25 | I6 | | 27 | 7.4 | 220 | 4.7 | 56 | 80 |
| | | | | | | 10 | 27 | 140 |
| 12.5×30 | I7 | | 39 | 5.1 | 310 | 27 | 9.8 | 210 |
| 12.5×40 | I9 | | 56 | 3.6 | 440 | 33 | 8.0 | 280 |
| 16×20 | J5 | | 56 | 3.6 | 440 | 47 | 5.6 | 400 |
| | | | 33 | 6.0 | 220 | 27 | 9.8 | 220 |
| 16×25 | J6 | | 22 | 9.0 | 200 | 22 | 12 | 220 |
| | | | 47 | 4.2 | 340 | 33 | 8.0 | 280 |
| 16×31.5 | J7 | | 47 | 3.4 | 280 | 47 | 3.4 | 280 |
| | | | 68 | 2.9 | 465 | 47 | 5.6 | 380 |
| 16×35.5 | J8 | | 33 | 6.0 | 245 | 47 | 5.6 | 420 |
| 16×40 | J9 | | 68 | 2.9 | 465 | 56 | 4.7 | 520 |
| 18×20 | K5 | | 82 | 2.4 | 500 | 68 | 3.9 | 520 |
| | | | 100 | 2.0 | 525 | 82 | 3.2 | 680 |
| 18×25 | K6 | | 22 | 9.0 | 200 | | | |
| | | | 47 | 4.2 | 335 | 39 | 6.8 | 330 |
| 18×31.5 | K7 | | 33 | 6.0 | 245 | 68 | 3.9 | 420 |
| | | | 68 | 2.9 | 450 | 68 | 3.9 | 420 |
| 18×35.5 | K8 | | 47 | 4.2 | 300 | | | |
| | | | 82 | 2.4 | 500 | 82 | 3.2 | 580 |
| 18×40 | K9 | | 100 | 2.0 | 525 | | | |
| 18×45 | KA | | — | — | — | 100 | 2.7 | 750 |
| 18×50 | KB | | 120 | 1.7 | 785 | 120 | 2.2 | 800 |
| | | | 150 | 1.3 | 865 | 150 | 1.8 | 920 |
| | | | — | — | — | 180 | 1.5 | 1100 |

(Note) Rated ripple current : 105°C , 120Hz ; ESR. : 20°C , 120Hz

NOTE : Design, Specifications are subject to change without notice.
It is recommended that you shall obtain technical specifications from ELNA to ensure that the component is suitable for your use.

105°C Use, Miniature, High-Ripple, Long Life Capacitors

GREEN CAP 105°C 10000hours

- Higher ripple current.
- Guarantees 5000 to 10000 hours at 105°C.
- Best-suited to electronic ballast.

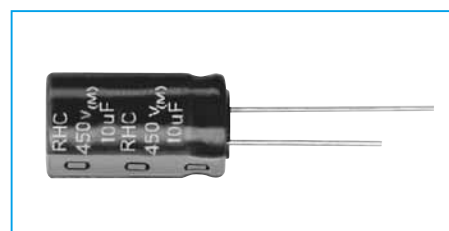
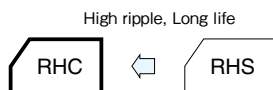

Marking color : White print on a black sleeve

Specifications

| Item | Performance | |
|--|---|---|
| Category temperature range (°C) | -25 to +105 | |
| Rated Voltage (V) | 160 to 450 | |
| Tolerance at rated capacitance (%) | ±20 (20°C,120Hz) | |
| Leakage current (µA) | Less than 0.04CV + 100 (after 1 minutes) C : Rated capacitance (µF), V : Rated voltage (V) (20°C) | |
| Tangent of loss angle (tanδ) | Rated voltage (V) | 160 to 250 350 to 450 |
| | Tangent of loss angle | 0.10 (0.15*) 0.12 (0.20*) |
| * The black circles in the capacitance column correspond. (20°C,120Hz) | | |
| Characteristics at high and low temperature | Rated voltage (V) | 160 to 250 350 to 450 |
| | Impedance ratio Z-25°C/Z+20°C | 3 6 |
| (120Hz) | | |
| Endurance (105°C) (Applied ripple current) | Test time | φ10×12.5 : 5000 hours φ10×16 to 20 : 8000 hours φ12.5 to 18 : 10000 hours |
| | Leakage current | The initial specific value or less |
| | Capacitance change | Within -30% to +30% of initial value |
| | Tangent of loss angle | 300% or less of the initial specified value |
| Shelf life (105°C) | Test time | 1000 hours |
| | Leakage current | The initial specific value or less |
| | Capacitance change | Within -20% to +20% of initial value |
| | Tangent of loss angle | 200% or less of the initial specified value |
| Voltage application treatment | | |
| Applicable standards | JIS C 5101-01, -04 1998 (IEC 60384-1 1992, 60384-4 1985) | |

Outline Drawing

Unit : mm

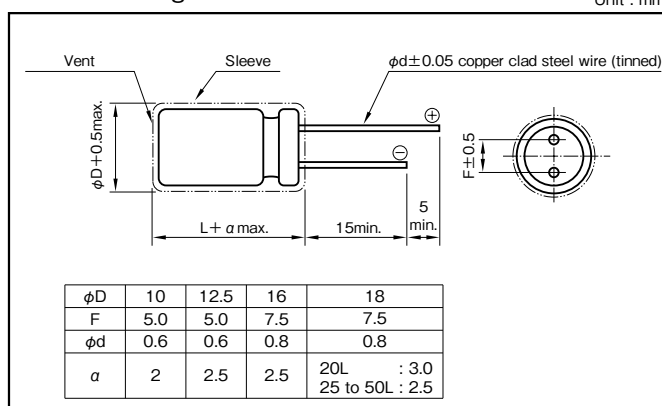

Coefficient of Frequency for Rated Ripple Current

| Rated capacitance (µF) | Frequency (Hz) | | | |
|------------------------|----------------|------|------|------|
| | 120 | 1k | 10k | 100k |
| 1 to 5.6 | 0.20 | 0.40 | 0.80 | 1 |
| 6.8 to 18 | 0.30 | 0.60 | 0.90 | 1 |
| 22 to 82 | 0.40 | 0.70 | 0.90 | 1 |
| 100 to 680 | 0.45 | 0.75 | 0.90 | 1 |

Part numbering system (example : 400V10µF)

| | | | | | | | | |
|-------------|---|----------------------|--------------------------|------------------------------|---------------|-----------------|---|------------------------|
| RHC | — | 400 V | 100 | M | H5 # | B | — | □ |
| Series code | | Rated voltage symbol | Rated capacitance symbol | Capacitance tolerance symbol | Casing symbol | Optional symbol | | Taping(Forming) symbol |

Standard Ratings

| Rated voltage(V) | | | 160 | | | 200 | | | 250 | | | 350 | | |
|-------------------|------------------|-------|------------------------------|-----------------|------------------------------------|------------------------------|-----------------|------------------------------------|------------------------------|-----------------|------------------------------------|------------------------------|-----------------|------------------------------------|
| Case φD×L (mm) | Casing symbol | Item | Rated capacitance (μF) | ESR (Ω max.) | Rated ripple current (mArms) | Rated capacitance (μF) | ESR (Ω max.) | Rated ripple current (mArms) | Rated capacitance (μF) | ESR (Ω max.) | Rated ripple current (mArms) | Rated capacitance (μF) | ESR (Ω max.) | Rated ripple current (mArms) |
| 10×12.5 | H3 | ● 27 | 7.4 | 350 | 4.7 | 28 | 200 | 4.7 | 28 | 200 | 1.5 | 106 | 100 | |
| | | | | | ● 12 | 17 | 340 | ● 8.2 | 24 | 300 | 2.2 | 72 | 140 | |
| | | | | | ● 10 | 13 | 320 | ● 6.8 | 20 | 250 | 3.3 | 48 | 180 | |
| | | | | | ● 39 | 5.1 | 600 | ● 22 | 9.0 | 450 | ● 12 | 22 | 360 | |
| 10×16 | H4 | ● 39 | 5.1 | 600 | 6.8 | 20 | 220 | 6.8 | 20 | 250 | 4.7 | 34 | 220 | |
| | | | | | ● 27 | 7.4 | 500 | ● 10 | 13 | 320 | 5.6 | 28 | 250 | |
| | | | | | ● 22 | 6.0 | 500 | ● 22 | 6.0 | 500 | ● 6.8 | 23 | 280 | |
| | | | | | ● 33 | 4.0 | 650 | ● 33 | 6.0 | 525 | ● 10 | 16 | 350 | |
| 10×20 | H5 | ● 33 | 2.8 | 750 | 33 | 4.0 | 650 | ● 33 | 6.0 | 525 | ● 15 | 18 | 465 | |
| | | | | | ● 22 | 6.0 | 500 | ● 33 | 6.0 | 525 | ● 15 | 18 | 465 | |
| | | | | | ● 22 | 6.0 | 500 | ● 22 | 6.0 | 500 | ● 15 | 18 | 465 | |
| | | | | | ● 47 | 2.8 | 750 | ● 33 | 6.0 | 525 | ● 15 | 18 | 465 | |
| 10×25 | H6 | ● 68 | 2.9 | 910 | ● 56 | 3.6 | 860 | ● 33 | 4.0 | 720 | ● 22 | 12 | 525 | |
| | | | | | ● 39 | 5.1 | 660 | ● 39 | 5.1 | 660 | ● 22 | 12 | 525 | |
| | | | | | ● 47 | 2.8 | 750 | ● 47 | 4.2 | 775 | ● 27 | 9.8 | 585 | |
| 10×30 | H7 | ● 82 | 2.4 | 1110 | ● 68 | 2.9 | 1010 | ● 47 | 4.2 | 775 | ● 27 | 9.8 | 585 | |
| | | | | | ● 68 | 2.9 | 1010 | ● 47 | 4.2 | 775 | ● 27 | 9.8 | 585 | |
| 12.5×20 | I5 | ● 100 | 2.0 | 1275 | 47 | 2.8 | 980 | ● 33 | 4.0 | 800 | ● 22 | 7.2 | 650 | |
| | | | | | ● 68 | 2.9 | 1120 | ● 33 | 4.0 | 800 | ● 27 | 9.8 | 700 | |
| | | | | | ● 100 | 2.0 | 1300 | ● 47 | 2.8 | 980 | ● 39 | 6.8 | 825 | |
| 12.5×25 | I6 | ● 120 | 1.7 | 1500 | ● 100 | 2.0 | 1300 | ● 68 | 2.9 | 1260 | ● 39 | 6.8 | 825 | |
| | | | | | ● 120 | 2.0 | 1375 | ● 68 | 2.9 | 1260 | ● 39 | 6.8 | 825 | |
| | | | | | ● 120 | 1.7 | 1500 | ● 120 | 2.0 | 1375 | ● 68 | 2.9 | 1260 | |
| 12.5×30 | I7 | ● 150 | 1.3 | 1700 | ● 120 | 1.7 | 1540 | ● 82 | 2.4 | 1410 | ● 56 | 4.7 | 1050 | |
| | | | | | ● 150 | 1.3 | 1700 | ● 82 | 2.4 | 1410 | ● 56 | 4.7 | 1050 | |
| 12.5×35 | I8 | ● 180 | 1.1 | 1965 | ● 150 | 1.3 | 1840 | ● 100 | 2.0 | 1465 | ● 68 | 3.9 | 1210 | |
| 12.5×40 | I9 | ● 220 | 0.9 | 2310 | ● 180 | 1.1 | 2120 | ● 120 | 1.7 | 1710 | ● 82 | 3.2 | 1375 | |
| 16×20 | J5 | ● 68 | 2.0 | 1180 | 68 | 2.0 | 1300 | ● 68 | 2.0 | 1300 | ● 33 | 4.8 | 900 | |
| | | | | | ● 100 | 1.3 | 1420 | ● 100 | 2.0 | 1420 | ● 82 | 2.4 | 1410 | |
| | | | | | ● 180 | 1.1 | 1900 | ● 100 | 2.0 | 1420 | ● 82 | 2.4 | 1410 | |
| 16×25 | J6 | ● 150 | 0.9 | 1890 | ● 150 | 1.3 | 1890 | 100 | 1.3 | 1530 | ● 68 | 3.9 | 1400 | |
| | | | | | | | | ● 220 | 0.9 | 2265 | ● 120 | 1.7 | 1675 | ● 68 |
| 16×31.5 | J7 | ● 330 | 0.6 | 3000 | ● 180 | 1.1 | 2200 | ● 150 | 1.3 | 1740 | ● 82 | 3.2 | 1560 | |
| | | | | | ● 220 | 0.9 | 2420 | ● 150 | 1.3 | 1740 | ● 82 | 3.2 | 1560 | |
| 16×35.5 | J8 | ● 390 | 0.5 | 3330 | ● 270 | 0.7 | 2710 | ● 180 | 1.1 | 2210 | ● 100 | 2.7 | 1640 | |
| 16×40 | J9 | ● 470 | 0.4 | 3775 | ● 330 | 0.6 | 3120 | ● 220 | 0.9 | 2530 | ● 120 | 2.2 | 1830 | |
| 18×20 | K5 | ● 180 | 1.1 | 1900 | — | — | — | ● 100 | 2.0 | 1530 | ● 68 | 3.9 | 1375 | |
| 18×25 | K6 | ● 220 | 0.6 | 2370 | ● 220 | 0.9 | 2380 | ● 150 | 1.3 | 1940 | 68 | 2.3 | 1470 | |
| | | | | | | | | | | | ● 270 | 0.7 | 2510 | ● 150 |
| 18×31.5 | K7 | ● 330 | 0.6 | 2865 | ● 270 | 0.7 | 2750 | ● 220 | 0.9 | 2200 | ● 100 | 2.7 | 1650 | |
| | | | | | | | | | | | ● 120 | 2.2 | 1760 | ● 120 |
| 18×35.5 | K8 | ● 470 | 0.4 | 3810 | ● 330 | 0.6 | 3100 | ● 270 | 0.7 | 2460 | ● 150 | 1.8 | 2085 | |
| 18×40 | K9 | ● 560 | 0.4 | 4230 | ● 390 | 0.5 | 3275 | ● 330 | 0.6 | 2660 | ● 180 | 1.5 | 2265 | |
| 18×45 | KA | ● 680 | 0.3 | 4365 | ● 470 | 0.4 | 3475 | — | — | — | ● 220 | 1.2 | 2530 | |
| 18×50 | KB | — | — | — | ● 560 | 0.4 | 3900 | ● 390 | 0.5 | 3555 | — | — | — | |

| Rated voltage(V) | | | 400 | | | 450 | | | | | |
|-------------------|------------------|-------|------------------------------|-----------------|------------------------------------|------------------------------|-----------------|------------------------------------|-------|-----|------|
| Case φD×L (mm) | Casing symbol | Item | Rated capacitance (μF) | ESR (Ω max.) | Rated ripple current (mArms) | Rated capacitance (μF) | ESR (Ω max.) | Rated ripple current (mArms) | | | |
| 10×12.5 | H3 | ● 1 | 159 | 70 | ● 3.9 | 68 | 200 | 200 | | | |
| | | | | | | | | | 1.5 | 106 | 100 |
| | | | | | | | | | 2.2 | 72 | 140 |
| | | | | | | | | | ● 3.3 | 80 | 160 |
| 10×16 | H4 | ● 3.3 | 48 | 180 | ● 2.2 | 72 | 150 | 150 | | | |
| | | | | | | | | | 4.7 | 34 | 220 |
| | | | | | | | | | ● 10 | 27 | 315 |
| 10×20 | H5 | ● 5.6 | 28 | 250 | ● 4.7 | 34 | 220 | 220 | | | |
| | | | | | | | | | 6.8 | 23 | 280 |
| | | | | | | | | | 10 | 16 | 350 |
| | | | | | | | | | ● 15 | 18 | 420 |
| 10×25 | H6 | ● 18 | 15 | 445 | ● 15 | 18 | 500 | 500 | | | |
| 10×30 | H7 | ● 22 | 12 | 525 | ● 22 | 12 | 535 | 535 | | | |
| 12.5×20 | I5 | ● 15 | 11 | 550 | ● 10 | 16 | 450 | 450 | | | |
| | | | | | | | | | ● 22 | 12 | 650 |
| 12.5×25 | I6 | ● 22 | 7.2 | 760 | ● 15 | 11 | 600 | 600 | | | |
| | | | | | | | | | ● 27 | 9.8 | 760 |
| 12.5×30 | I7 | ● 33 | 4.8 | 720 | ● 33 | 8.0 | 725 | 725 | | | |
| | | | | | | | | | ● 47 | 5.6 | 920 |
| | | | | | | | | | ● 47 | 5.6 | 920 |
| 12.5×35 | I8 | ● 47 | 3.4 | 960 | ● 33 | 8.0 | 800 | 800 | | | |
| | | | | | | | | | ● 56 | 4.7 | 1260 |
| 12.5×40 | I9 | — | — | — | ● 47 | 5.6 | 1010 | 1010 | | | |
| 16×20 | J5 | ● 22 | 7.2 | 760 | ● 22 | 7.2 | 730 | 730 | | | |
| | | | | | | | | | ● 33 | 8.0 | 900 |
| 16×25 | J6 | ● 47 | 5.6 | 1180 | ● 33 | 4.8 | 980 | 980 | | | |
| | | | | | | | | | ● 39 | 6.8 | 935 |
| 16×31.5 | J7 | ● 68 | 3.9 | 1350 | ● 56 | 4.7 | 1125 | 1125 | | | |
| 16×35.5 | J8 | ● 100 | 2.7 | 1550 | ● 68 | 3.9 | 1250 | 1250 | | | |
| 16×40 | J9 | ● 120 | 2.2 | 1740 | ● 82 | 3.2 | 1650 | 1650 | | | |
| 18×20 | K5 | ● 56 | 4.7 | 1350 | ● 39 | 6.8 | 935 | 935 | | | |
| 18×25 | K6 | ● 68 | 3.9 | 1470 | ● 47 | 3.4 | 1200 | 1200 | | | |
| | | | | | | | | | ● 68 | 3.9 | 1260 |
| 18×31.5 | K7 | ● 100 | 2.7 | 1720 | ● 82 | 3.2 | 1360 | 1360 | | | |
| | | | | | | | | | ● 120 | 2.2 | 1760 |
| 18×35.5 | K8 | ● 120 | 2.2 | 1760 | ● 100 | 2.7 | 1685 | 1685 | | | |
| 18×40 | K9 | ● 120 | 2.2 | 1945 | ● 120 | 2.2 | 1865 | 1865 | | | |
| | | | | | | | | | ● 150 | 1.8 | 1930 |
| 18×45 | KA | ● 150 | 1.8 | 2215 | — | — | — | — | | | |
| 18×50 | KB | — | — | — | ● 150 | 1.8 | 2040 | 2040 | | | |

(Note) Rated ripple current : 105°C , 100kHz ; ESR. : 20°C , 120Hz

NOTE : Design, Specifications are subject to change without notice.
It is recommended that you shall obtain technical specifications from ELNA to ensure that the component is suitable for your use.

105°C Use, Miniature, High-Ripple, Long Life Capacitors

GREEN CAP 105°C 12000hours

- Higher ripple current.
- Guarantees 8000 to 12000 hours at 105°C.
- Best-suited to electronic ballast.

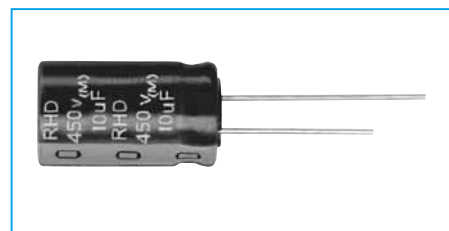
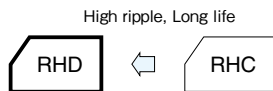

Marking color : White print on a black sleeve

Specifications

| Item | Performance | | |
|---|--|--|------------|
| Category temperature range (°C) | -25 to +105 | | |
| Rated Voltage (V) | 160 to 450 | | |
| Tolerance at rated capacitance (%) | ±20 (20°C,120Hz) | | |
| Leakage current(μA) | Less than 0.04CV + 100 (after 1 minutes) C:Rated capacitance (μF),V:Rated Voltage (V) (20°C) | | |
| Tangent of loss angle (tanδ) | Rated voltage (V) | 160 to 250 | 350 to 450 |
| | Tangent of loss angle | 0.15 | 0.20 |
| Characteristics at high and low temperature | Rated voltage (V) | 160 to 250 | 350 to 450 |
| | Impedance ratio Z-25°C/Z+20°C | 3 | 6 |
| Endurance (105°C) (Applied ripple current) | Test time | φ10×12.5L : 8000hours φ10×16,20L : 10000hours φ10×30L, φ12.5 to φ18 : 12000hours | |
| | Leakage current | The initial specified value or less | |
| | Capacitance change | Within -30% to +30% of initial value | |
| | Tangent of loss angle | 300% or less of the initial specified value | |
| Shelf life (105°C) | Test time | 1000hours | |
| | Leakage current | The initial specified value or less | |
| | Capacitance change | Within -20% to +20% of initial value | |
| | Tangent of loss angle | 200% or less of the initial specified value | |
| Voltage application treatment | | | |
| Applicable Standards | JIS C 5101-01, -04 1998 (IEC 60384-1 1992,60384-4 1985) | | |

Outline Drawing

Unit : mm

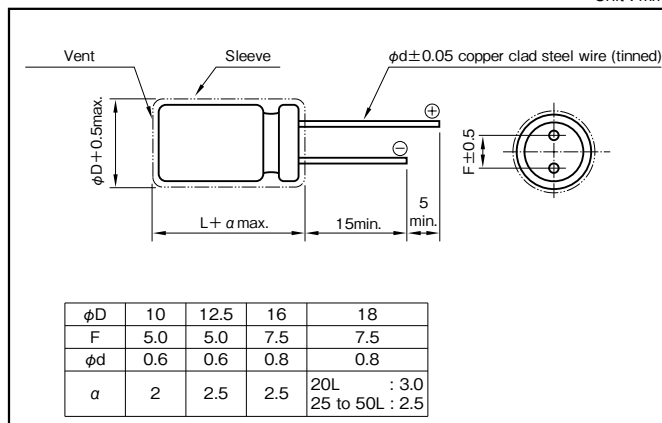

Coefficient of Frequency for Rated Ripple Current

| Rated voltage (V) | Frequency (Hz) | | | | |
|-------------------|----------------|------|------|------|------|
| | 50 | 120 | 1k | 10k | 100k |
| 160 to 450 | 0.30 | 0.50 | 0.80 | 0.90 | 1 |

Part numbering system (example : 400V47μF)

| | | | | | | | | | | |
|-------------|---|----------------------|---|--------------------------|------------------------------|---------------|---|-----------------|---|------------------------|
| RHD | — | 400 | V | 470 | M | K6 | # | B | — | □ |
| Series code | | Rated voltage symbol | | Rated capacitance symbol | Capacitance tolerance symbol | Casing symbol | | Optional symbol | | Taping(Forming) symbol |

Standard Ratings

| Rated voltage(V) | | | 160 | | | 200 | | | 250 | | | 350 | | | | | |
|------------------|------------------|------|------------------------------|-----------------|------------------------------------|------------------------------|-----------------|------------------------------------|------------------------------|-----------------|------------------------------------|------------------------------|-----------------|------------------------------------|----|-----|-----|
| Case φD×L(mm) | Casing symbol | Item | Rated capacitance (μF) | ESR (Ω max.) | Rated ripple current (mArms) | Rated capacitance (μF) | ESR (Ω max.) | Rated ripple current (mArms) | Rated capacitance (μF) | ESR (Ω max.) | Rated ripple current (mArms) | Rated capacitance (μF) | ESR (Ω max.) | Rated ripple current (mArms) | | | |
| 10×12.5 | H3 | | — | — | — | 10 | 20 | 250 | 6.8 | 29 | 250 | 4.7 | 56 | 200 | | | |
| | | | 10 | 20 | 250 | 12 | 17 | 310 | | | | 5.6 | 47 | 220 | | | |
| 10×16 | H4 | | 10 | 20 | 250 | 10 | 20 | 250 | 22 | 9.0 | 350 | 6.8 | 39 | 220 | | | |
| | | | 39 | 5.1 | 490 | 22 | 9.0 | 360 | | | | 12 | 22 | 280 | | | |
| 10×20 | H5 | | 22 | 9.0 | 500 | 22 | 9.0 | 500 | 10 | 20 | 280 | 10 | 27 | 280 | | | |
| | | | 33 | 6.0 | 500 | 33 | 6.0 | 600 | | | | 33 | 6.0 | 500 | 15 | 18 | 360 |
| | | | 56 | 3.6 | 620 | 39 | 5.1 | 640 | | | | 39 | 5.1 | 570 | 22 | 12 | 440 |
| 10×25 | H6 | | 68 | 2.9 | 760 | 47 | 4.2 | 660 | 39 | 5.1 | 570 | 22 | 12 | 440 | | | |
| | | | 56 | 3.6 | 620 | 56 | 3.6 | 680 | | | | 47 | 4.2 | 670 | 27 | 9.8 | 500 |
| 10×30 | H7 | | 100 | 2.0 | 980 | 56 | 3.6 | 700 | 47 | 4.2 | 670 | 27 | 9.8 | 500 | | | |
| | | | 68 | 2.9 | 800 | 33 | 6.0 | 600 | | | | 22 | 9.0 | 600 | 22 | 12 | 350 |
| 12.5×20 | I5 | | 47 | 4.2 | 660 | 47 | 4.2 | 660 | 33 | 6.0 | 600 | 22 | 9.0 | 600 | | | |
| | | | 82 | 2.4 | 1040 | 56 | 3.6 | 700 | | | | 47 | 4.2 | 650 | 27 | 9.8 | 600 |
| | | | 68 | 2.9 | 760 | 68 | 2.9 | 940 | | | | 47 | 4.2 | 720 | 39 | 6.8 | 770 |
| 12.5×25 | I6 | | 100 | 2.0 | 1260 | 100 | 2.0 | 1240 | 68 | 2.9 | 1020 | 68 | 2.9 | 1020 | | | |
| | | | 68 | 2.9 | 760 | 82 | 2.4 | 1200 | | | | 56 | 4.7 | 980 | | | |
| 12.5×30 | I7 | | — | — | — | 120 | 1.7 | 1430 | 82 | 2.4 | 1200 | 56 | 4.7 | 980 | | | |
| 12.5×35 | I8 | | 180 | 1.1 | 1880 | 150 | 1.3 | 1700 | 100 | 2.0 | 1400 | 68 | 3.9 | 1160 | | | |
| 12.5×40 | I9 | | 220 | 0.9 | 2170 | 180 | 1.1 | 1950 | — | — | — | 82 | 3.2 | 1300 | | | |
| 16×20 | J5 | | 68 | 2.9 | 760 | 68 | 2.9 | 760 | 47 | 4.2 | 720 | 33 | 8.0 | 500 | | | |
| | | | 150 | 1.3 | 1560 | 100 | 2.0 | 1260 | 82 | 2.4 | 1150 | 47 | 5.6 | 860 | | | |
| 16×25 | J6 | | 100 | 2.0 | 1120 | 150 | 1.3 | 1680 | 68 | 2.9 | 920 | 68 | 3.9 | 1130 | | | |
| | | | 180 | 1.1 | 1850 | — | — | — | 120 | 1.7 | 1260 | 100 | 2.0 | 1200 | | | |
| 16×31.5 | J7 | | 270 | 0.7 | 2500 | 220 | 0.9 | 2220 | 150 | 1.3 | 1800 | 82 | 3.2 | 1350 | | | |
| | | | 330 | 0.6 | 2730 | 270 | 0.7 | 2480 | 180 | 1.1 | 2040 | 100 | 2.7 | 1510 | | | |
| 16×40 | J9 | | 390 | 0.5 | 3090 | 330 | 0.6 | 2840 | 220 | 0.9 | 2330 | 120 | 2.2 | 1750 | | | |
| 18×20 | K5 | | 100 | 2.0 | 1120 | 100 | 2.0 | 1120 | 68 | 2.9 | 920 | 47 | 5.6 | 660 | | | |
| | | | 180 | 1.1 | 1800 | 150 | 1.3 | 1300 | 100 | 2.0 | 1330 | 56 | 4.7 | 1000 | | | |
| 18×25 | K6 | | 150 | 1.3 | 1360 | 220 | 0.9 | 1400 | 150 | 1.3 | 1730 | 82 | 3.2 | 1290 | | | |
| | | | 220 | 0.9 | 1400 | — | — | — | — | — | — | — | — | — | — | | |
| | | | 270 | 0.7 | 2340 | 220 | 0.9 | 1700 | 220 | 0.9 | 2240 | 100 | 2.7 | 1420 | | | |
| 18×31.5 | K7 | | 330 | 0.6 | 2580 | 270 | 0.7 | 2530 | 270 | 0.7 | 2550 | 150 | 1.8 | 2115 | | | |
| | | | 390 | 0.5 | 3000 | 330 | 0.6 | 2840 | 270 | 0.7 | 2550 | 150 | 1.8 | 2115 | | | |
| 18×35.5 | K8 | | 470 | 0.4 | 3420 | 330 | 0.6 | 2840 | 270 | 0.7 | 2550 | 150 | 1.8 | 2115 | | | |
| 18×40 | K9 | | 560 | 0.4 | 3780 | 390 | 0.5 | 3170 | 330 | 0.6 | 2910 | 180 | 1.5 | 2100 | | | |
| 18×45 | KA | | 680 | 0.3 | 4240 | 470 | 0.4 | 3500 | — | — | — | 220 | 1.2 | 2400 | | | |
| 18×50 | KB | | — | — | — | 560 | 0.4 | 3880 | 390 | 0.5 | 3240 | — | — | — | | | |

| Rated voltage(V) | | | 400 | | | 450 | | |
|------------------|------------------|------|------------------------------|-----------------|------------------------------------|------------------------------|-----------------|------------------------------------|
| Case φD×L(mm) | Casing symbol | Item | Rated capacitance (μF) | ESR (Ω max.) | Rated ripple current (mArms) | Rated capacitance (μF) | ESR (Ω max.) | Rated ripple current (mArms) |
| 10×12.5 | H3 | | 4.7 | 56 | 220 | 3.9 | 68 | 120 |
| | | | 3.3 | 80 | 200 | 4.7 | 56 | 130 |
| 10×16 | H4 | | 6.8 | 39 | 220 | 6.8 | 39 | 140 |
| | | | 10 | 27 | 280 | 4.7 | 56 | 140 |
| 10×20 | H5 | | 10 | 27 | 280 | 6.8 | 39 | 150 |
| | | | 12 | 22 | 330 | 10 | 27 | 280 |
| | | | 12 | 22 | 290 | 12 | 22 | 290 |
| 10×25 | H6 | | 18 | 15 | 500 | 15 | 18 | 380 |
| 10×30 | H7 | | 22 | 12 | 600 | 22 | 12 | 470 |
| 12.5×20 | I5 | | 18 | 15 | 540 | 10 | 27 | 320 |
| | | | 15 | 18 | 380 | 15 | 18 | 380 |
| | | | 18 | 15 | 500 | 18 | 15 | 500 |
| 12.5×25 | I6 | | 27 | 9.8 | 710 | 22 | 12 | 620 |
| | | | 27 | 9.8 | 690 | 27 | 9.8 | 690 |
| 12.5×30 | I7 | | 47 | 5.6 | 910 | 33 | 8.0 | 700 |
| 12.5×35 | I8 | | — | — | — | 39 | 6.8 | 920 |
| 12.5×40 | I9 | | 56 | 4.7 | 1090 | 47 | 5.6 | 1050 |
| 16×20 | J5 | | 22 | 12 | 430 | 27 | 9.8 | 700 |
| | | | 33 | 8.0 | 790 | 22 | 12 | 560 |
| 16×25 | J6 | | 47 | 5.6 | 1180 | 47 | 5.6 | 1000 |
| | | | 68 | 3.9 | 1250 | 56 | 4.7 | 1160 |
| 16×31.5 | J7 | | 82 | 3.2 | 1380 | 68 | 3.9 | 1300 |
| 16×40 | J9 | | 100 | 2.7 | 1510 | 82 | 3.2 | 1480 |
| | | | 120 | 2.2 | 1740 | 22 | 12 | 560 |
| 18×20 | K5 | | 33 | 8.0 | 640 | 22 | 12 | 560 |
| | | | 47 | 5.6 | 910 | 39 | 6.8 | 870 |
| 18×25 | K6 | | 68 | 3.9 | 1250 | 33 | 8.0 | 700 |
| | | | 82 | 3.2 | 1280 | 56 | 4.7 | 1120 |
| 18×31.5 | K7 | | 100 | 2.7 | 1520 | 82 | 3.2 | 1450 |
| | | | 100 | 2.7 | 1640 | 68 | 3.9 | 1130 |
| 18×35.5 | K8 | | 120 | 2.2 | 1700 | 100 | 2.7 | 1640 |
| | | | 120 | 2.2 | 1740 | 100 | 2.7 | 1670 |
| 18×40 | K9 | | 150 | 1.8 | 1900 | 120 | 2.2 | 1830 |
| | | | 150 | 1.8 | 1970 | — | — | — |
| 18×45 | KA | | 180 | 1.5 | 2100 | — | — | — |
| 18×50 | KB | | — | — | — | 150 | 1.8 | 2100 |

(Note) Rated ripple current : 105°C , 100kHz ; ESR. : 20°C , 120Hz

NOTE : Design, Specifications are subject to change without notice.
It is recommended that you shall obtain technical specifications from ELNA to ensure that the component is suitable for your use.

125°C Use, Miniature, Low ESR, High Vibration Resistance Capacitors

| | | | | |
|-----------|---------------------------|---------|-----------------|-----------------------|
| GREEN CAP | High Vibration Resistance | Low ESR | 125°C 5000hours | Anti-cleaning solvent |
|-----------|---------------------------|---------|-----------------|-----------------------|

- Vibration resistance (40G, 10 to 2000Hz, X, Y, Z = per 2hours).
- For Automotive application (ABS and electric power steering etc.)
- Guaranteed 5000 hours at 125°C

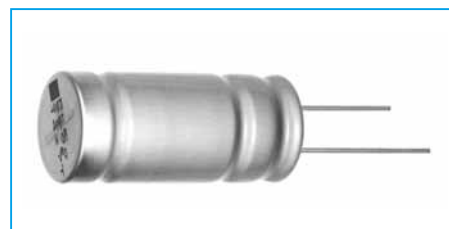
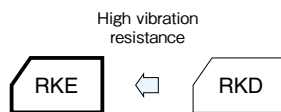

Marking color : Black print

Specifications

| Item | Performance | | | |
|---|--|---|------|------|
| Category temperature range (°C) | -40 to +125 | | | |
| Tolerance at rated capacitance (%) | ±20 (20°C, 120Hz) | | | |
| Leakage current (µA) | Less than 0.01CV or 3 whichever is larger (after 2 minutes) C : Rated capacitance (µF), V : Rated voltage (V) (20°C) | | | |
| Tangent of loss angle (tanδ) | Rated voltage (V) | 25 | 35 | 50 |
| | tanδ (max.) | 0.14 | 0.12 | 0.10 |
| 0.02 is added to every 1000µF increase over 1000µF. (20°C, 120Hz) | | | | |
| Characteristics at high and low temperature | Rated voltage (V) | 25 | 35 | 50 |
| | Impedance ratio (max.) Z-40°C/Z+20°C | 3 | 3 | 3 |
| (120Hz) | | | | |
| Endurance (125°C) (Applied ripple current) | Test time | 5000 hours | | |
| | Leakage current | The initial specified value or less | | |
| | Percentage of capacitance change | Within ±30% of initial value | | |
| | Tangent of the loss angle | 300% or less of the initial specified value | | |
| Shelf life (125°C) | Test time : 1000hours ; other items are the same as those for the endurance. Voltage application treatment : According to JIS C5101 -1 | | | |
| Vibration | Vibration test condition | | | |
| | Frequency range | 10 to 2000Hz | | |
| | Displacement amplitude | 1.5 mm max. | | |
| | Acceleration | 40G (392m/s ²) max. | | |
| | Sweep rate | 0.5 octave/min. | | |
| | Vibration axis and duration | X, Y, Z per 2 hours, total 6 hours | | |
| | Fixation | Capacitor mounted by its body which is rigidly clamped to the work surface. | | |
| | Specification after test | | | |
| Leakage current | The initial specified value or less | | | |
| Percentage of capacitance change | Within ±30% of initial value | | | |
| Tangent of the loss angle | 300% or less of the initial specified value | | | |
| Applicable standards | JIS C5101-1, -4 1998 (IEC 60384-1 1992, -4 1985) | | | |

Outline Drawing

Unit : mm

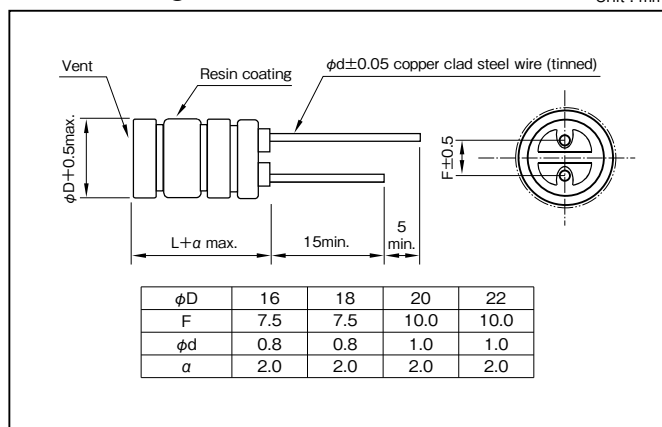

Coefficient of Frequency for Rated Ripple Current

| Rated capacitance (µF) | Frequency (Hz) | | | |
|------------------------|----------------|------|------|------|
| | 120 | 1k | 10k | 100k |
| 1200 to 82000 | 0.85 | 0.95 | 1.00 | 1 |

Part numbering system (example : 35V2700µF)

| | | | | | | | | | |
|-------------|---|----------------------|---|--------------------------|------------------------------|---------------|---|---|----------------|
| RKE | — | 35 | V | 272 | M | K7 | # | — | □ |
| Series code | | Rated voltage symbol | | Rated capacitance symbol | Capacitance tolerance symbol | Casing symbol | | | Forming symbol |

Standard Ratings

| Rated voltage(V) Rated capacitance (μF) | Item | 25 | | | | | 35 | | | | | 50 | | | | |
|--|---------|-------------------|------------------|--------------|-------|------------------------------------|-------------------|------------------|--------------|-------|------------------------------------|-------------------|------------------|--------------|-------|------------------------------------|
| | | Case φD×L (mm) | Casing symbol | ESR (Ω max.) | | Rated ripple current (mAmps) | Case φD×L (mm) | Casing symbol | ESR (Ω max.) | | Rated ripple current (mAmps) | Case φD×L (mm) | Casing symbol | ESR (Ω max.) | | Rated ripple current (mAmps) |
| | | | | 20°C | -40°C | | | | 20°C | -40°C | | | | 20°C | -40°C | |
| 1200 | — | — | — | — | — | — | — | — | — | — | 16×31.5 | J7 | 0.033 | 0.19 | 2940 | |
| 1500 | — | — | — | — | — | 16×31.5 | J7 | 0.024 | 0.14 | 3160 | 16×35.5 | J8 | 0.028 | 0.16 | 3300 | |
| 2200 | — | — | — | — | — | 16×35.5 | J8 | 0.023 | 0.13 | 3590 | 18×35.5 | K8 | 0.027 | 0.15 | 3520 | |
| 2700 | 16×31.5 | J7 | 0.024 | 0.14 | 3160 | 18×31.5 | K7 | 0.020 | 0.11 | 3410 | — | — | — | — | — | |
| 3300 | 16×35.5 | J8 | 0.023 | 0.13 | 3590 | 18×35.5 | K8 | 0.019 | 0.10 | 3840 | 20×40 | L9 | 0.022 | 0.12 | 3930 | |
| 4700 | 18×31.5 | K7 | 0.020 | 0.11 | 3410 | 18×40 | K9 | 0.017 | 0.094 | 4250 | — | — | — | — | — | |
| 5600 | 18×35.5 | K8 | 0.019 | 0.10 | 3840 | 20×40 | L9 | 0.017 | 0.094 | 4500 | — | — | — | — | — | |
| 6800 | 18×40 | K9 | 0.017 | 0.094 | 4250 | — | — | — | — | — | — | — | — | — | — | |
| 7800 | 20×40 | L9 | 0.017 | 0.094 | 4500 | — | — | — | — | — | — | — | — | — | — | |
| 8200 | 22×40 | N9 | 0.017 | 0.094 | 4750 | — | — | — | — | — | — | — | — | — | — | |

(Note) Rated ripple current : 125°C , 100kHz ; ESR : 100kHz

125°C Use, Miniature, Low Impedance Capacitors

| | | | |
|-----------|---------|-----------------|-----------------------|
| GREEN CAP | Low ESR | 125°C 5000hours | Anti-cleaning solvent |
|-----------|---------|-----------------|-----------------------|

- Smaller and low ESR than RK series.
- Guarantees 5000 hours at 125°C ($\phi 8$: 2000h, $\phi 10$: 3000h)

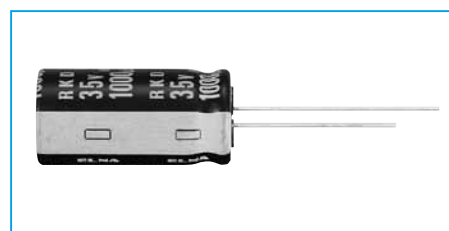

Marking color : White print on a black sleeve

Specifications

| Item | Performance | | | | | | | | | | | | | | | | | | |
|--|--|--|------|------|------|------|------|------|-----|-----|------------------------|---------------|------|------|------|------|------|------|------|
| Category temperature range (°C) | -40 to +125 | | | | | | | | | | | | | | | | | | |
| Tolerance at rated capacitance (%) | ± 20 (20°C, 120Hz) | | | | | | | | | | | | | | | | | | |
| Leakage current (μA) | Less than 0.01CV or 4 whichever is larger (after 2 minutes) C : Rated capacitance (μF), V : Rated voltage (V) (20°C) | | | | | | | | | | | | | | | | | | |
| Tangent of loss angle ($\tan \delta$) | <table border="1"> <tr> <th>Rated voltage (V)</th> <th>10</th> <th>16</th> <th>25</th> <th>35</th> <th>50</th> <th>63</th> <th>80</th> <th>100</th> </tr> <tr> <th>$\tan \delta$ (max.)</th> <td>0.20</td> <td>0.16</td> <td>0.14</td> <td>0.12</td> <td>0.10</td> <td>0.10</td> <td>0.08</td> <td>0.08</td> </tr> </table> | Rated voltage (V) | 10 | 16 | 25 | 35 | 50 | 63 | 80 | 100 | $\tan \delta$ (max.) | 0.20 | 0.16 | 0.14 | 0.12 | 0.10 | 0.10 | 0.08 | 0.08 |
| | Rated voltage (V) | 10 | 16 | 25 | 35 | 50 | 63 | 80 | 100 | | | | | | | | | | |
| $\tan \delta$ (max.) | 0.20 | 0.16 | 0.14 | 0.12 | 0.10 | 0.10 | 0.08 | 0.08 | | | | | | | | | | | |
| 0.02 is added to every 1000 μF increase over 1000 μF . (20°C, 120Hz) | | | | | | | | | | | | | | | | | | | |
| Characteristics at high and low temperature | <table border="1"> <tr> <th>Rated voltage (V)</th> <th>10</th> <th>16</th> <th>25</th> <th>35</th> <th>50</th> <th>63</th> <th>80</th> <th>100</th> </tr> <tr> <th>Impedance ratio (max.)</th> <td>Z-40°C/Z+20°C</td> <td>4</td> <td>3</td> <td>3</td> <td>3</td> <td>3</td> <td>3</td> <td>3</td> </tr> </table> | Rated voltage (V) | 10 | 16 | 25 | 35 | 50 | 63 | 80 | 100 | Impedance ratio (max.) | Z-40°C/Z+20°C | 4 | 3 | 3 | 3 | 3 | 3 | 3 |
| | Rated voltage (V) | 10 | 16 | 25 | 35 | 50 | 63 | 80 | 100 | | | | | | | | | | |
| Impedance ratio (max.) | Z-40°C/Z+20°C | 4 | 3 | 3 | 3 | 3 | 3 | 3 | | | | | | | | | | | |
| (120Hz) | | | | | | | | | | | | | | | | | | | |
| Endurance (125°C) (Applied ripple current) | Test time | 5000 hours ($\phi 8$: 2000 hours) ($\phi 10$: 3000 hours) | | | | | | | | | | | | | | | | | |
| | Leakage current | The initial specified value or less | | | | | | | | | | | | | | | | | |
| | Percentage of capacitance change | Within $\pm 30\%$ of initial value | | | | | | | | | | | | | | | | | |
| | Tangent of the loss angle | 300% or less of the initial specified value | | | | | | | | | | | | | | | | | |
| Shelf life (125°C) | Test time : 1000hours ; other items are the same as those for the endurance. Voltage application treatment : According to JIS C5101 -1 | | | | | | | | | | | | | | | | | | |
| Applicable standards | JIS C5101-1, -4 1998 (IEC 60384-1 1992, -4 1985) | | | | | | | | | | | | | | | | | | |

Outline Drawing

Unit : mm

| | | | | | | |
|----------|-----|-----|------|-----|-----|------|
| ϕD | 8 | 10 | 12.5 | 16 | 18 | 20 |
| F | 3.5 | 5.0 | 5.0 | 7.5 | 7.5 | 10.0 |
| ϕd | 0.6 | 0.6 | 0.6 | 0.8 | 0.8 | 1.0 |
| a | 1.0 | 2.0 | 2.0 | 2.0 | 2.0 | 2.0 |

(Note) Whisker preventive structure is possible.

Coefficient of Frequency for Rated Ripple Current

| Rated capacitance (μF) | Frequency (Hz) | | | |
|-------------------------------|----------------|------|------|------------|
| | 50 · 60 | 120 | 1k | 10k · 100k |
| 100 to 330 | 0.55 | 0.65 | 0.85 | 1 |
| 390 to 1000 | 0.70 | 0.75 | 0.90 | 1 |
| 1200 to 8200 | 0.80 | 0.85 | 0.95 | 1 |

Part numbering system (example : 10V1000 μF)

| | | | | | | | | | |
|-------------|---|----------------------|---|--------------------------|------------------------------|---------------|---|---|------------------------|
| RKD | — | 10 | V | 102 | M | H5 | # | — | |
| Series code | | Rated voltage symbol | | Rated capacitance symbol | Capacitance tolerance symbol | Casing symbol | | | Taping(Forming) symbol |

If it is whisker preventive structure, should change “#” into “G”.

Standard Ratings

| Rated voltage (V) Rated capacitance (μF) Item | 10 | | | | 16 | | | | 25 | | | | 35 | | | | | | | | | | | |
|---|-----------|---------------|--------------|---|-----------|---------------|--------------|---|-----------|---------------|--------------|---|-----------|---------------|--------------|---|---------|----|-------|------|-------|----|-------|------|
| | Case | Casing symbol | ESR (Ω max.) | Rated ripple current (mA _{rms}) | Case | Casing symbol | ESR (Ω max.) | Rated ripple current (mA _{rms}) | Case | Casing symbol | ESR (Ω max.) | Rated ripple current (mA _{rms}) | Case | Casing symbol | ESR (Ω max.) | Rated ripple current (mA _{rms}) | | | | | | | | |
| | φD×L (mm) | | | | φD×L (mm) | | | | φD×L (mm) | | | | φD×L (mm) | | | | | | | | | | | |
| 100 | — | — | — | — | 8×12 | G3 | 0.153 | 501 | 8×12 | G3 | 0.153 | 501 | 8×12 | G3 | 0.153 | 501 | | | | | | | | |
| 220 | 8×12 | G3 | 0.153 | 501 | 8×12 | G3 | 0.153 | 501 | 8×12 | G3 | 0.153 | 501 | 10×12.5 | H3 | 0.098 | 732 | | | | | | | | |
| | | | | | 10×12.5 | H3 | 0.098 | 732 | 10×12.5 | H3 | 0.098 | 732 | 10×16 | H4 | 0.075 | 953 | | | | | | | | |
| 330 | 8×12 | G3 | 0.153 | 501 | 8×12 | G3 | 0.153 | 501 | 10×12.5 | H3 | 0.098 | 732 | 10×16 | H4 | 0.075 | 953 | | | | | | | | |
| | 10×12.5 | H3 | 0.098 | 732 | 10×12.5 | H3 | 0.098 | 732 | 10×16 | H4 | 0.075 | 953 | 10×20 | H5 | 0.057 | 1140 | | | | | | | | |
| 470 | 10×12.5 | H3 | 0.098 | 732 | 10×16 | H4 | 0.075 | 953 | 10×16 | H4 | 0.075 | 953 | 10×20 | H5 | 0.057 | 1140 | | | | | | | | |
| | | | | | | | | | 10×20 | H5 | 0.057 | 1140 | 12.5×20 | I5 | 0.040 | 1820 | 12.5×25 | I6 | 0.032 | 2400 | | | | |
| 1000 | 10×20 | H5 | 0.057 | 1140 | 10×20 | H5 | 0.057 | 1140 | 12.5×20 | I5 | 0.040 | 1820 | 12.5×25 | I6 | 0.032 | 2400 | | | | | | | | |
| | 12.5×15 | I4 | 0.059 | 1380 | 12.5×20 | I5 | 0.040 | 1820 | 12.5×25 | I6 | 0.032 | 2400 | 16×25 | J6 | 0.024 | 3100 | | | | | | | | |
| 1200 | — | — | — | — | — | — | — | — | 12.5×20 | I5 | 0.040 | 1820 | 12.5×30 | I7 | 0.029 | 2560 | | | | | | | | |
| | | | | | | | | | | | | | 16×20 | J5 | 0.044 | 1930 | 16×16 | J4 | 0.044 | 1930 | 16×20 | J5 | 0.044 | 2280 |
| 1500 | — | — | — | — | — | — | — | — | — | — | — | — | 12.5×35 | I8 | 0.023 | 2970 | | | | | | | | |
| | | | | | | | | | | | | | 16×31.5 | J7 | 0.020 | 3180 | 18×25 | K6 | 0.022 | 3200 | 18×25 | K6 | 0.022 | 3200 |
| 1800 | — | — | — | — | — | — | — | — | 12.5×25 | I6 | 0.032 | 2400 | 12.5×40 | I9 | 0.020 | 3600 | | | | | | | | |
| | | | | | | | | | | | | | 16×20 | J5 | 0.032 | 2280 | 16×25 | J6 | 0.024 | 3100 | 16×25 | J6 | 0.024 | 3100 |
| 2200 | 12.5×25 | I6 | 0.032 | 2400 | 12.5×25 | I6 | 0.032 | 2400 | 12.5×30 | I7 | 0.029 | 2560 | 16×31.5 | J7 | 0.020 | 3160 | | | | | | | | |
| | 16×20 | J5 | 0.032 | 2280 | 16×25 | J6 | 0.024 | 3100 | 16×25 | J6 | 0.024 | 3100 | 16×35.5 | J8 | 0.019 | 3590 | | | | | | | | |
| | 18×16 | K4 | 0.041 | 2170 | 18×20 | K5 | 0.029 | 2490 | 18×20 | K5 | 0.029 | 2490 | 18×25 | K6 | 0.022 | 3200 | | | | | | | | |
| 2700 | — | — | — | — | — | — | — | — | 12.5×35 | I8 | 0.023 | 2970 | 16×35.5 | J8 | 0.019 | 3590 | | | | | | | | |
| | | | | | | | | | | | | | 16×25 | J6 | 0.024 | 3100 | 18×31.5 | K7 | 0.018 | 3410 | 20×25 | L6 | 0.022 | 3500 |
| | | | | | | | | | | | | | 18×20 | K5 | 0.029 | 2490 | 18×20 | K5 | 0.029 | 2490 | 20×25 | L6 | 0.022 | 3500 |
| 3300 | 16×25 | J6 | 0.024 | 3100 | 16×31.5 | J7 | 0.020 | 3160 | 12.5×40 | I9 | 0.020 | 3600 | 16×40 | J9 | 0.017 | 4300 | | | | | | | | |
| | 18×20 | K5 | 0.029 | 2490 | 18×25 | K6 | 0.022 | 3200 | 16×31.5 | J7 | 0.020 | 3160 | 18×35.5 | K8 | 0.017 | 4200 | | | | | | | | |
| | — | — | — | — | — | — | — | — | 16×35.5 | J8 | 0.019 | 3590 | 20×30 | L7 | 0.019 | 4000 | | | | | | | | |
| 3900 | — | — | — | — | — | — | — | — | 16×35.5 | J8 | 0.019 | 3590 | — | — | — | — | | | | | | | | |
| | | | | | | | | | | | | | 18×25 | K6 | 0.022 | 3200 | — | — | — | — | | | | |
| 4700 | 16×31.5 | J7 | 0.020 | 3160 | 16×35.5 | J8 | 0.019 | 3590 | 18×35.5 | K8 | 0.017 | 4200 | 18×40 | K9 | 0.016 | 4600 | | | | | | | | |
| | 18×25 | K6 | 0.022 | 3200 | 18×31.5 | K7 | 0.018 | 3410 | 20×25 | L6 | 0.022 | 3500 | 20×35.5 | L8 | 0.016 | 4700 | | | | | | | | |
| 5600 | — | — | — | — | — | — | — | — | 16×40 | J9 | 0.017 | 4300 | 20×40 | L9 | 0.015 | 5100 | | | | | | | | |
| | | | | | | | | | | | | | | | | | 18×35.5 | K8 | 0.017 | 4200 | — | — | — | — |
| | | | | | | | | | | | | | | | | | 20×30 | L7 | 0.019 | 4000 | — | — | — | — |
| 6800 | — | — | — | — | — | — | — | — | 18×40 | K9 | 0.016 | 4600 | — | — | — | — | | | | | | | | |
| | | | | | | | | | | | | | | | | | 20×35.5 | L8 | 0.016 | 4700 | — | — | — | — |
| 8200 | — | — | — | — | — | — | — | — | 20×40 | L9 | 0.015 | 5100 | — | — | — | — | | | | | | | | |

| Rated voltage (V) Rated capacitance (μF) Item | 50 | | | | 63 | | | | 80 | | | | 100 | | | | |
|---|-----------|---------------|--------------|---|-----------|---------------|--------------|---|-----------|---------------|--------------|---|-----------|---------------|--------------|---|------|
| | Case | Casing symbol | ESR (Ω max.) | Rated ripple current (mA _{rms}) | Case | Casing symbol | ESR (Ω max.) | Rated ripple current (mA _{rms}) | Case | Casing symbol | ESR (Ω max.) | Rated ripple current (mA _{rms}) | Case | Casing symbol | ESR (Ω max.) | Rated ripple current (mA _{rms}) | |
| | φD×L (mm) | | | | φD×L (mm) | | | | φD×L (mm) | | | | φD×L (mm) | | | | |
| 220 | 10×20 | H5 | 0.081 | 960 | — | — | — | — | — | — | — | — | 16×20 | J5 | 0.11 | 1580 | |
| 330 | — | — | — | — | — | — | — | — | — | 16×20 | J5 | 0.11 | 1790 | 16×25 | J6 | 0.079 | 1690 |
| 470 | 12.5×20 | I5 | 0.057 | 1500 | 16×20 | J5 | 0.085 | 1790 | 16×25 | J6 | 0.079 | 2030 | 16×35.5 | J8 | 0.052 | 2500 | |
| 560 | — | — | — | — | — | — | — | — | 18×25 | K6 | 0.064 | 2280 | 16×40 | J9 | 0.045 | 2700 | |
| 820 | 12.5×30 | I7 | 0.038 | 2150 | 16×31.5 | J7 | 0.053 | 2330 | 18×35.5 | K8 | 0.044 | 2890 | 18×40 | K9 | 0.039 | 2880 | |
| 1000 | 16×25 | J6 | 0.031 | 2620 | 16×35.5 | J8 | 0.044 | 2580 | 18×40 | K9 | 0.039 | 3210 | — | — | — | — | |
| 1800 | 18×31.5 | K7 | 0.025 | 3140 | 18×40 | K9 | 0.032 | 3210 | — | — | — | — | — | — | — | — | |
| 2200 | 18×35.5 | K8 | 0.022 | 3510 | — | — | — | — | — | — | — | — | — | — | — | — | |

(Note) Rated ripple current : 125°C , 100kHz ; ESR : 20°C , 100kHz

125°C Use, Long Life Capacitors

| | | | | |
|-----------|----------------------|---------|-----------------|-----------------------|
| GREEN CAP | Vibration Resistance | Low ESR | 125°C 5000hours | Anti-cleaning solvent |
|-----------|----------------------|---------|-----------------|-----------------------|

- Guarantees 5000 hours at 125°C.
- Best-suited to smoothing circuits and control circuits for industrial equipment power supplies of which long life and high reliability are required.
- NC terminal added items are lineup for vibration resistance. (30G guaranteed : 20mL or less)

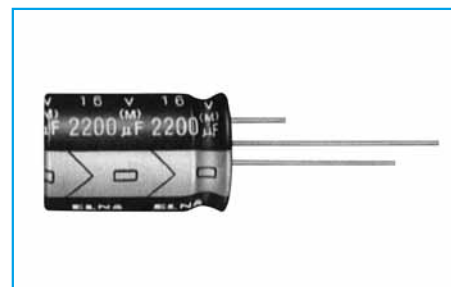

Marking color : White print on a black sleeve

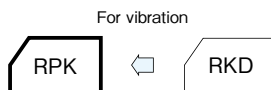

Specifications

| Item | Performance | | | | | | | | | | | | | | | | | | |
|---|---|---|------|------|------|------|------|------|-----|-----|--------------------------------------|------|------|------|------|------|------|------|------|
| Category temperature range (°C) | -40 to +125 | | | | | | | | | | | | | | | | | | |
| Tolerance at rated capacitance (%) | ±20 (20°C, 120Hz) | | | | | | | | | | | | | | | | | | |
| Leakage current (µA) | Less than 0.01CV or 4 whichever is larger (after 2 minutes) C : Rated capacitance (µF), V : Rated voltage (V) (20°C) | | | | | | | | | | | | | | | | | | |
| Tangent of loss angle (tanδ) | <table border="1"> <tr> <td>Rated voltage (V)</td> <td>10</td> <td>16</td> <td>25</td> <td>35</td> <td>50</td> <td>63</td> <td>80</td> <td>100</td> </tr> <tr> <td>tanδ (max.)</td> <td>0.20</td> <td>0.16</td> <td>0.14</td> <td>0.12</td> <td>0.10</td> <td>0.10</td> <td>0.08</td> <td>0.08</td> </tr> </table> | Rated voltage (V) | 10 | 16 | 25 | 35 | 50 | 63 | 80 | 100 | tanδ (max.) | 0.20 | 0.16 | 0.14 | 0.12 | 0.10 | 0.10 | 0.08 | 0.08 |
| | Rated voltage (V) | 10 | 16 | 25 | 35 | 50 | 63 | 80 | 100 | | | | | | | | | | |
| tanδ (max.) | 0.20 | 0.16 | 0.14 | 0.12 | 0.10 | 0.10 | 0.08 | 0.08 | | | | | | | | | | | |
| 0.02 is added to every 1000µF increase over 1000µF. (20°C, 120Hz) | | | | | | | | | | | | | | | | | | | |
| Characteristics at high and low temperature | <table border="1"> <tr> <td>Rated voltage (V)</td> <td>10</td> <td>16</td> <td>25</td> <td>35</td> <td>50</td> <td>63</td> <td>80</td> <td>100</td> </tr> <tr> <td>Impedance ratio (max.) Z-40°C/Z+20°C</td> <td>4</td> <td>3</td> <td>3</td> <td>3</td> <td>3</td> <td>3</td> <td>3</td> <td>3</td> </tr> </table> | Rated voltage (V) | 10 | 16 | 25 | 35 | 50 | 63 | 80 | 100 | Impedance ratio (max.) Z-40°C/Z+20°C | 4 | 3 | 3 | 3 | 3 | 3 | 3 | 3 |
| | Rated voltage (V) | 10 | 16 | 25 | 35 | 50 | 63 | 80 | 100 | | | | | | | | | | |
| Impedance ratio (max.) Z-40°C/Z+20°C | 4 | 3 | 3 | 3 | 3 | 3 | 3 | 3 | | | | | | | | | | | |
| (120Hz) | | | | | | | | | | | | | | | | | | | |
| Endurance (125°C) (Applied ripple current) | Test time | 5000 hours | | | | | | | | | | | | | | | | | |
| | Leakage current | The initial specified value or less | | | | | | | | | | | | | | | | | |
| | Percentage of capacitance change | Within ±30% of initial value | | | | | | | | | | | | | | | | | |
| | Tangent of the loss angle | 300% or less of the initial specified value | | | | | | | | | | | | | | | | | |
| Shelf life (125°C) | Test time : 1000hours ; other items are the same as those for the endurance. Voltage application treatment : According to JIS C5101 -1 | | | | | | | | | | | | | | | | | | |
| Applicable standards | JIS C5101-1, -4 1998 (IEC 60384-1 1992, -4 1985) | | | | | | | | | | | | | | | | | | |

Outline Drawing

Unit : mm

| | | | | |
|----|------|------|------|------|
| φD | 12.5 | 16 | 18 | 20 |
| F | 5.0 | 7.5 | 7.5 | 10.0 |
| F1 | 2.5 | 3.75 | 3.75 | 5.0 |
| φd | 0.8 | 0.8 | 0.8 | 1.0 |
| a | 2.0 | 2.0 | 2.0 | 2.0 |

(Note) Since NC terminal is not insulated, it should be mounted at a position electronically independent from all other parts of the circuit.
 (Note) Whisker preventive structure is possible.

Coefficient of Frequency for Rated Ripple Current

| Rated capacitance (µF) | Frequency (Hz) | | | |
|------------------------|----------------|------|------|------------|
| | 50 · 60 | 120 | 1k | 10k · 100k |
| 220 to 330 | 0.55 | 0.65 | 0.85 | 1 |
| 390 to 1000 | 0.70 | 0.75 | 0.90 | 1 |
| 1200 to 8200 | 0.80 | 0.85 | 0.95 | 1 |

Part numbering system (example : 16V2200µF)

| | | | | | | | | | |
|-------------|---|----------------------|---|--------------------------|------------------------------|---------------|----|---|------------------------|
| RPK | — | 16 | V | 222 | M | J6 | D# | — | □ |
| Series code | | Rated voltage symbol | | Rated capacitance symbol | Capacitance tolerance symbol | Casing symbol | | | Taping(Forming) symbol |

If it is whisker preventive structure, should change " #" into " G ".

Standard Ratings

| Rated voltage (V) | Item | 10 | | | | 16 | | | | 25 | | | | 35 | | | | | | |
|-------------------|---------|-----------|---------------|----------|----------------------|-----------|---------------|----------|----------------------|-----------|---------------|----------|----------------------|-----------|---------------|----------|----------------------|----|-------|------|
| | | Case | Casing symbol | ESR | Rated ripple current | Case | Casing symbol | ESR | Rated ripple current | Case | Casing symbol | ESR | Rated ripple current | Case | Casing symbol | ESR | Rated ripple current | | | |
| | | φD×L (mm) | | (Ω max.) | (mA _{rms}) | φD×L (mm) | | (Ω max.) | (mA _{rms}) | φD×L (mm) | | (Ω max.) | (mA _{rms}) | φD×L (mm) | | (Ω max.) | (mA _{rms}) | | | |
| 470 | | — | — | — | — | — | — | — | — | — | — | — | — | — | — | — | — | | | |
| 1000 | 12.5×15 | I4 | 0.059 | 1380 | 12.5×20 | I5 | 0.040 | 1820 | 12.5×20 | I5 | 0.040 | 1820 | 12.5×25 | I6 | 0.032 | 2400 | | | | |
| | | | | | 16×16 | J4 | 0.044 | 1930 | 16×16 | J4 | 0.044 | 1930 | 16×25 | J6 | 0.024 | 3100 | | | | |
| 1200 | | — | — | — | — | — | — | — | 12.5×20 | I5 | 0.040 | 1820 | 12.5×30 | I7 | 0.029 | 2560 | | | | |
| 1500 | — | — | — | — | — | — | — | — | — | — | — | — | 16×20 | J5 | 0.044 | 2280 | | | | |
| | | | | | | | | | | | | | 12.5×35 | I8 | 0.023 | 2970 | 16×31.5 | J7 | 0.020 | 3180 |
| | | | | | | | | | | | | | 18×25 | K6 | 0.022 | 3200 | 18×25 | K6 | 0.022 | 3200 |
| 1800 | — | — | — | — | — | — | — | — | 12.5×25 | I6 | 0.032 | 2400 | 12.5×40 | I9 | 0.020 | 3600 | | | | |
| | | | | | | | | | 16×20 | J5 | 0.032 | 2280 | 16×25 | J6 | 0.024 | 3100 | | | | |
| 2200 | 12.5×25 | I6 | 0.032 | 2400 | 12.5×25 | I6 | 0.032 | 2400 | 12.5×30 | I7 | 0.029 | 2560 | 16×25 | J6 | 0.024 | 3100 | | | | |
| | 16×20 | J5 | 0.032 | 2280 | 16×25 | J6 | 0.024 | 3100 | 16×25 | J6 | 0.024 | 3100 | 16×35.5 | J8 | 0.019 | 3590 | | | | |
| | 18×16 | K4 | 0.041 | 2170 | 18×20 | K5 | 0.029 | 2490 | 18×20 | K5 | 0.029 | 2490 | 18×25 | K6 | 0.022 | 3200 | | | | |
| 2700 | — | — | — | — | — | — | — | — | 12.5×35 | I8 | 0.023 | 2970 | 16×35.5 | J8 | 0.019 | 3590 | | | | |
| | | | | | | | | | 16×25 | J6 | 0.024 | 3100 | 18×31.5 | K7 | 0.018 | 3410 | | | | |
| | | | | | | | | | 18×20 | K5 | 0.029 | 2490 | 20×25 | L6 | 0.022 | 3500 | | | | |
| 3300 | 16×25 | J6 | 0.024 | 3100 | 16×31.5 | J7 | 0.020 | 3160 | 12.5×40 | I9 | 0.020 | 3600 | 16×40 | J9 | 0.017 | 4300 | | | | |
| | 18×20 | K5 | 0.029 | 2490 | 18×25 | K6 | 0.022 | 3200 | 16×31.5 | J7 | 0.020 | 3160 | 18×35.5 | K8 | 0.017 | 4200 | | | | |
| 3900 | — | — | — | — | — | — | — | — | 16×35.5 | J8 | 0.019 | 3590 | — | — | — | — | | | | |
| | | | | | | | | | 18×25 | K6 | 0.022 | 3200 | — | — | — | — | | | | |
| 4700 | 16×31.5 | J7 | 0.020 | 3160 | 16×35.5 | J8 | 0.019 | 3590 | 18×35.5 | K8 | 0.017 | 4200 | 18×40 | K9 | 0.016 | 4600 | | | | |
| | 18×25 | K6 | 0.022 | 3200 | 18×31.5 | K7 | 0.018 | 3410 | 20×25 | L6 | 0.022 | 3500 | 20×35.5 | L8 | 0.016 | 4700 | | | | |
| 5600 | — | — | — | — | — | — | — | — | 16×40 | J9 | 0.017 | 4300 | 20×40 | L9 | 0.015 | 5100 | | | | |
| | | | | | | | | | 18×35.5 | K8 | 0.017 | 4200 | | | | | | | | |
| | | | | | | | | | 20×30 | L7 | 0.019 | 4000 | | | | | | | | |
| 6800 | — | — | — | — | — | — | — | — | 18×40 | K9 | 0.016 | 4600 | — | — | — | — | | | | |
| | | | | | | | | | 20×35.5 | L8 | 0.016 | 4700 | | | | | | | | |
| 8200 | | — | — | — | — | — | — | — | 20×40 | L9 | 0.015 | 5100 | — | — | — | — | | | | |

| Rated voltage (V) | Item | 50 | | | | 63 | | | | 80 | | | | 100 | | | |
|-------------------|---------|-----------|---------------|----------|----------------------|-----------|---------------|----------|----------------------|-----------|---------------|----------|----------------------|-----------|---------------|----------|----------------------|
| | | Case | Casing symbol | ESR | Rated ripple current | Case | Casing symbol | ESR | Rated ripple current | Case | Casing symbol | ESR | Rated ripple current | Case | Casing symbol | ESR | Rated ripple current |
| | | φD×L (mm) | | (Ω max.) | (mA _{rms}) | φD×L (mm) | | (Ω max.) | (mA _{rms}) | φD×L (mm) | | (Ω max.) | (mA _{rms}) | φD×L (mm) | | (Ω max.) | (mA _{rms}) |
| 220 | | — | — | — | — | — | — | — | — | — | — | — | — | — | — | — | — |
| 330 | | — | — | — | — | — | — | — | — | — | — | — | — | — | — | — | — |
| 470 | 12.5×20 | I5 | 0.057 | 1500 | 16×20 | J5 | 0.085 | 1790 | 16×20 | J5 | 0.11 | 1790 | 16×20 | J5 | 0.11 | 1580 | |
| 560 | | — | — | — | — | — | — | — | 16×25 | J6 | 0.079 | 2030 | 16×35.5 | J8 | 0.052 | 2500 | |
| 820 | 12.5×30 | I7 | 0.038 | 2150 | 16×31.5 | J7 | 0.053 | 2330 | 18×25 | K6 | 0.064 | 2280 | 16×40 | J9 | 0.045 | 2700 | |
| 1000 | 16×25 | J6 | 0.031 | 2620 | 16×35.5 | J8 | 0.044 | 2580 | 18×35.5 | K8 | 0.044 | 2890 | 18×40 | K9 | 0.039 | 2880 | |
| 1800 | 18×31.5 | K7 | 0.025 | 3140 | 18×40 | K9 | 0.032 | 3210 | 18×40 | K9 | 0.039 | 3210 | — | — | — | — | |
| 2200 | 18×35.5 | K8 | 0.022 | 3510 | — | — | — | — | — | — | — | — | — | — | — | — | |

(Note) Rated ripple current : 125°C, 100kHz ; ESR : 20°C, 100kHz

135°C Use, Miniature, Low ESR Capacitors

| | | | |
|-----------|---------|--------------------|-----------------------|
| GREEN CAP | Low ESR | 135°C 3000hours | Anti-cleaning solvent |
|-----------|---------|--------------------|-----------------------|

- High temperature guaranteed and low ESR series for automotive.
- Guarantees 3000 hours at 135°C. ($\phi 10$: 2000 hours)



High temperature

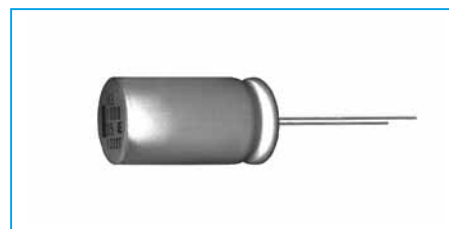

Marking color : Black print

Specifications

| Item | Performance | | | | | | | | | | | | | | | | | | |
|--|--|---|------|------|------|------|------|------|-----|-----|------------------------|---------------|------|------|------|------|------|------|------|
| Category temperature range (°C) | -40 to +135 | | | | | | | | | | | | | | | | | | |
| Tolerance at rated capacitance (%) | ± 20 (20°C, 120Hz) | | | | | | | | | | | | | | | | | | |
| Leakage current (μA) | Less than 0.01CV or 4 whichever is larger (after 2 minutes) C : Rated capacitance (μF), V : Rated voltage (V) (20°C) | | | | | | | | | | | | | | | | | | |
| Tangent of loss angle (tan δ) | <table border="1"> <tr> <th>Rated voltage (V)</th> <td>10</td><td>16</td><td>25</td><td>35</td><td>50</td><td>63</td><td>80</td><td>100</td> </tr> <tr> <th>tanδ (max.)</th> <td>0.20</td><td>0.16</td><td>0.14</td><td>0.12</td><td>0.10</td><td>0.10</td><td>0.08</td><td>0.08</td> </tr> </table> | Rated voltage (V) | 10 | 16 | 25 | 35 | 50 | 63 | 80 | 100 | tan δ (max.) | 0.20 | 0.16 | 0.14 | 0.12 | 0.10 | 0.10 | 0.08 | 0.08 |
| | Rated voltage (V) | 10 | 16 | 25 | 35 | 50 | 63 | 80 | 100 | | | | | | | | | | |
| tan δ (max.) | 0.20 | 0.16 | 0.14 | 0.12 | 0.10 | 0.10 | 0.08 | 0.08 | | | | | | | | | | | |
| 0.02 is added to every 1000 μF increase over 1000 μF . (20°C, 120Hz) | | | | | | | | | | | | | | | | | | | |
| Characteristics at high and low temperature | <table border="1"> <tr> <th>Rated voltage (V)</th> <td>10</td><td>16</td><td>25</td><td>35</td><td>50</td><td>63</td><td>80</td><td>100</td> </tr> <tr> <th>Impedance ratio (max.)</th> <td>Z-40°C/Z+20°C</td><td>4</td><td>3</td><td>3</td><td>3</td><td>3</td><td>3</td><td>3</td> </tr> </table> | Rated voltage (V) | 10 | 16 | 25 | 35 | 50 | 63 | 80 | 100 | Impedance ratio (max.) | Z-40°C/Z+20°C | 4 | 3 | 3 | 3 | 3 | 3 | 3 |
| | Rated voltage (V) | 10 | 16 | 25 | 35 | 50 | 63 | 80 | 100 | | | | | | | | | | |
| Impedance ratio (max.) | Z-40°C/Z+20°C | 4 | 3 | 3 | 3 | 3 | 3 | 3 | | | | | | | | | | | |
| (120Hz) | | | | | | | | | | | | | | | | | | | |
| Endurance (135°C) (Applied ripple current) | Test time | 3000 hours ($\phi 10$: 2000 hours) | | | | | | | | | | | | | | | | | |
| | Leakage current | The initial specified value or less | | | | | | | | | | | | | | | | | |
| | Percentage of capacitance change | Within $\pm 30\%$ of initial value | | | | | | | | | | | | | | | | | |
| | Tangent of the loss angle | 300% or less of the initial specified value | | | | | | | | | | | | | | | | | |
| Shelf life (135°C) | Test time : 1000 hours; other items are the same as those for the endurance. Voltage application treatment | | | | | | | | | | | | | | | | | | |
| Applicable standards | JIS C5101-1, -4 1998 (IEC 60384-1 1992, -4 1985) | | | | | | | | | | | | | | | | | | |

Outline Drawing

Unit : mm

| | | | | |
|----------|-----|------|-----|-----|
| ϕD | 10 | 12.5 | 16 | 18 |
| F | 5.0 | 5.0 | 7.5 | 7.5 |
| ϕd | 0.6 | 0.6 | 0.8 | 0.8 |
| a | 2.0 | 2.0 | 2.0 | 2.0 |

Coefficient of Frequency for Rated Ripple Current

| Rated capacitance (μF) \ Frequency (Hz) | 50 · 60 | 120 | 1k | 10k · 100k |
|--|---------|------|------|------------|
| 220 to 330 | 0.50 | 0.85 | 0.95 | 1 |
| 470 to 1000 | 0.60 | 0.88 | 0.96 | 1 |
| 1200 to 6800 | 0.68 | 0.90 | 0.98 | 1 |

Part numbering system (example : 10V1000 μF)

| | | | | | | | | | |
|-------------|---|----------------------|---|--------------------------|------------------------------|---------------|---|---|------------------------|
| RKB | — | 10 | V | 102 | M | H5 | # | — | |
| Series code | | Rated voltage symbol | | Rated capacitance symbol | Capacitance tolerance symbol | Casing symbol | | | Taping(Forming) symbol |

Standard Ratings

| Rated voltage (V) | Item | 10 | | | | 16 | | | | 25 | | | | 35 | | | |
|-------------------|---------|-----------|---------------|----------|----------------------|-----------|---------------|----------|----------------------|-----------|---------------|----------|----------------------|-----------|---------------|----------|----------------------|
| | | Case | Casing symbol | ESR | Rated ripple current | Case | Casing symbol | ESR | Rated ripple current | Case | Casing symbol | ESR | Rated ripple current | Case | Casing symbol | ESR | Rated ripple current |
| | | φDXL (mm) | | (Ω max.) | (mArms) | φDXL (mm) | | (Ω max.) | (mArms) | φDXL (mm) | | (Ω max.) | (mArms) | φDXL (mm) | | (Ω max.) | (mArms) |
| 220 | — | — | — | — | 10×12.5 | H3 | 0.098 | 725 | 10×12.5 | H3 | 0.098 | 725 | 10×12.5 | H3 | 0.098 | 725 | |
| 330 | 10×12.5 | H3 | 0.098 | 725 | 10×12.5 | H3 | 0.098 | 725 | 10×12.5 | H3 | 0.098 | 725 | 10×16 | H4 | 0.075 | 951 | |
| | | | | | | | | | 10×16 | H4 | 0.075 | 951 | 10×20 | H5 | 0.057 | 1130 | |
| 470 | 10×12.5 | H3 | 0.098 | 725 | 10×16 | H4 | 0.075 | 951 | 10×16 | H4 | 0.075 | 951 | 10×20 | H5 | 0.057 | 1130 | |
| 1000 | 10×20 | H5 | 0.057 | 1130 | 10×20 | H5 | 0.057 | 1130 | 12.5×20 | I5 | 0.040 | 1550 | 12.5×25 | I6 | 0.032 | 1880 | |
| | 12.5×15 | I4 | 0.059 | 1130 | 12.5×20 | I5 | 0.040 | 1550 | 12.5×25 | I6 | 0.032 | 1880 | 12.5×30 | I7 | 0.029 | 2160 | |
| 1200 | — | — | — | — | — | — | — | — | 12.5×20 | I5 | 0.040 | 1550 | 16×20 | J5 | 0.032 | 2020 | |
| 1500 | — | — | — | — | — | — | — | — | — | — | — | — | 12.5×35 | I8 | 0.023 | 2580 | |
| 1800 | — | — | — | — | — | — | — | — | 12.5×25 | I6 | 0.032 | 1880 | 12.5×40 | I9 | 0.020 | 2920 | |
| | | | | | | | | | 16×20 | J5 | 0.032 | 2020 | 16×25 | J6 | 0.024 | 2550 | |
| 2200 | 12.5×25 | I6 | 0.032 | 1880 | 12.5×25 | I6 | 0.032 | 1880 | 12.5×30 | I7 | 0.029 | 2160 | 16×31.5 | J7 | 0.020 | 3040 | |
| | 16×20 | J5 | 0.032 | 2020 | 16×25 | J6 | 0.024 | 2550 | 16×25 | J6 | 0.024 | 2550 | 16×35.5 | J8 | 0.019 | 3280 | |
| 2700 | — | — | — | — | — | — | — | — | 12.5×35 | I8 | 0.023 | 2580 | 16×35.5 | J8 | 0.019 | 3280 | |
| | | | | | | | | | 16×25 | J6 | 0.024 | 2550 | 18×31.5 | K7 | 0.018 | 3410 | |
| 3300 | 16×25 | J6 | 0.024 | 2550 | 16×31.5 | J7 | 0.020 | 3040 | 12.5×40 | I9 | 0.020 | 2920 | 16×40 | J9 | 0.017 | 3630 | |
| | 18×20 | K5 | 0.029 | 2320 | 18×25 | K6 | 0.022 | 2880 | 16×31.5 | J7 | 0.020 | 3040 | 18×35.5 | K8 | 0.017 | 3710 | |
| 4700 | 16×31.5 | J7 | 0.020 | 3040 | 16×35.5 | J8 | 0.019 | 3280 | 16×35.5 | J8 | 0.019 | 3280 | 18×40 | K9 | 0.016 | 4000 | |
| | 18×25 | K6 | 0.022 | 2880 | 18×31.5 | K7 | 0.018 | 3410 | 18×31.5 | K7 | 0.018 | 3410 | | | | | |
| 5600 | — | — | — | — | — | — | — | — | 16×40 | J9 | 0.017 | 3630 | — | — | — | — | |
| 6800 | — | — | — | — | — | — | — | — | 18×40 | K9 | 0.016 | 4000 | — | — | — | — | |

| Rated voltage (V) | Item | 50 | | | | 63 | | | | 80 | | | | 100 | | | |
|-------------------|---------|-----------|---------------|----------|----------------------|-----------|---------------|----------|----------------------|-----------|---------------|----------|----------------------|-----------|---------------|----------|----------------------|
| | | Case | Casing symbol | ESR | Rated ripple current | Case | Casing symbol | ESR | Rated ripple current | Case | Casing symbol | ESR | Rated ripple current | Case | Casing symbol | ESR | Rated ripple current |
| | | φDXL (mm) | | (Ω max.) | (mArms) | φDXL (mm) | | (Ω max.) | (mArms) | φDXL (mm) | | (Ω max.) | (mArms) | φDXL (mm) | | (Ω max.) | (mArms) |
| 220 | 10×20 | H5 | 0.098 | 930 | — | — | — | — | — | — | — | — | 16×20 | J5 | 0.131 | 1070 | |
| 330 | — | — | — | — | — | — | — | — | 16×20 | J5 | 0.131 | 1070 | 16×25 | J6 | 0.097 | 1350 | |
| 470 | 12.5×20 | I5 | 0.070 | 1170 | 16×20 | J5 | 0.099 | 1230 | 16×25 | J6 | 0.097 | 1350 | 16×35.5 | J8 | 0.077 | 1740 | |
| 560 | — | — | — | — | — | — | — | — | 18×25 | K6 | 0.088 | 1530 | 16×40 | J9 | 0.069 | 1940 | |
| 820 | 12.5×30 | I7 | 0.047 | 1680 | 16×31.5 | J7 | 0.062 | 1850 | 18×35.5 | K8 | 0.069 | 1980 | 18×40 | K9 | 0.066 | 2120 | |
| 1000 | 16×25 | J6 | 0.039 | 1990 | 16×35.5 | J8 | 0.058 | 2010 | 18×40 | K9 | 0.066 | 2120 | — | — | — | — | |
| 1800 | 18×31.5 | K7 | 0.030 | 2670 | 18×40 | K9 | 0.053 | 2350 | — | — | — | — | — | — | — | — | |
| 2200 | 18×35.5 | K8 | 0.028 | 2900 | — | — | — | — | — | — | — | — | — | — | — | — | |

(Note) Rated ripple current : 135°C , 100kHz ; ESR : 20°C , 100kHz

150°C Use, Miniature, Low Impedance Capacitors

GREEN CAP Low Impedance 150°C 1000hours Anti-cleaning solvent

- 150°C, High temperature guaranteed.
- Guarantees 1000 hours at 150°C.

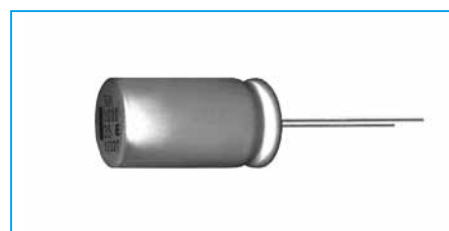
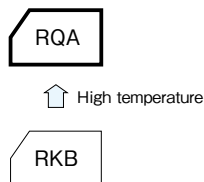

Marking color : Black print

Specifications

| Item | Performance | | | | | | |
|--|--|---|------|------|------|------|------|
| Category temperature range (°C) | -40 to +150 | | | | | | |
| Tolerance at rated capacitance (%) | ±20 (20°C,120Hz) | | | | | | |
| Leakage current (µA) | Less than 0.01CV or 4 whichever is larger (after 2 minutes) C : Rated capacitance (µF), V : Rated voltage (V) (20°C) | | | | | | |
| Tangent of loss angle (tanδ) | Rated voltage (V) | 10 | 16 | 25 | 35 | 50 | 63 |
| | tanδ (max.) | 0.20 | 0.16 | 0.14 | 0.12 | 0.10 | 0.10 |
| 0.02 is added to every 1000µF increase over 1000µF. (20°C,120Hz) | | | | | | | |
| Characteristics at high and low temperature | Rated voltage (V) | 10 | 16 | 25 | 35 | 50 | 63 |
| | Impedance ratio (max.) | Z-40°C/Z+20°C | 4 | 3 | 3 | 3 | 3 |
| (120Hz) | | | | | | | |
| Endurance (150°C) (Applied ripple current) | Test time | 1000 hours | | | | | |
| | Leakage current | The initial specified value or less | | | | | |
| | Percentage of capacitance change | Within ±30% of initial value | | | | | |
| | Tangent of the loss angle | 300% or less of the initial specified value | | | | | |
| Shelf life (150°C) | Test time : 1000hours ; other items are the same as those for the endurance. Voltage application treatment : According to JIS C5101 -1 | | | | | | |
| Applicable standards | JIS C5101 - 1, - 4 1998 (IEC 60384 - 1 1992, - 4 1985) | | | | | | |

Outline Drawing

Unit : mm

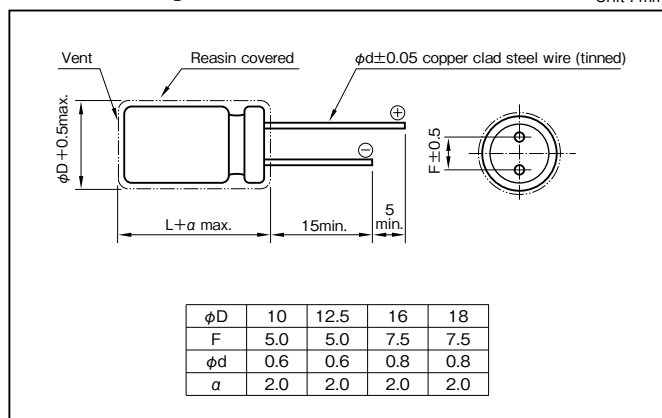

Coefficient of Frequency for Rated Ripple Current

| Rated capacitance (µF) | Frequency (Hz) | | | |
|------------------------|----------------|------|------|------------|
| | 50 · 60 | 120 | 1k | 10k · 100k |
| 220 to 330 | 0.50 | 0.85 | 0.95 | 1 |
| 470 to 1000 | 0.60 | 0.88 | 0.96 | 1 |
| 1500 to 10000 | 0.68 | 0.90 | 0.98 | 1 |

Part numbering system (example : 35V1000µF)

| | | | | | | | | | |
|-------------|---|----------------------|---|--------------------------|------------------------------|---------------|---|---|------------------------|
| RQA | — | 35 | V | 102 | M | I6 | # | — | □ |
| Series code | | Rated voltage symbol | | Rated capacitance symbol | Capacitance tolerance symbol | Casing symbol | | | Taping(Forming) symbol |

Standard Ratings

| Rated voltage (V) | Item | 10 | | | 16 | | | 25 | | | 35 | | |
|-------------------|---------|------|---------------|------------------------------|------|---------------|------------------------------|------|---------------|------------------------------|------|---------------|------------------------------|
| | | Case | Casing symbol | Rated ripple current (mArms) | Case | Casing symbol | Rated ripple current (mArms) | Case | Casing symbol | Rated ripple current (mArms) | Case | Casing symbol | Rated ripple current (mArms) |
| 220 | — | — | — | — | — | — | 10×14 | H3 | 300 | 10×14 | H3 | 300 | |
| 330 | — | — | — | — | — | — | 10×17 | H4 | 510 | 10×17 | H4 | 510 | |
| 470 | — | — | — | 10×17 | H4 | 510 | 10×22 | H5 | 820 | 10×22 | H5 | 820 | |
| 1000 | 10×22 | H5 | 820 | 10×22 | H5 | 820 | 12.5×27 | I6 | 1000 | 12.5×27 | I6 | 1000 | |
| 2200 | 12.5×27 | I6 | 1000 | 12.5×27 | I6 | 1000 | 16×28 | J6 | 1200 | 16×34.5 | J7 | 1370 | |
| 3300 | 16×28 | J7 | 1200 | 16×34.5 | J7 | 1370 | 16×38.5 | J8 | 1720 | 18×34.5 | K7 | 1670 | |
| 4700 | 16×34.5 | J6 | 1370 | 16×38.5 | J8 | 1720 | 18×38.5 | K8 | 1790 | 18×43 | K9 | 1870 | |

| Rated voltage (V) | Item | 50 | | | 63 | | |
|-------------------|---------|------|---------------|------------------------------|------|---------------|------------------------------|
| | | Case | Casing symbol | Rated ripple current (mArms) | Case | Casing symbol | Rated ripple current (mArms) |
| 470 | 12.5×22 | I5 | 1070 | 16×28 | J6 | 750 | |
| 1000 | 16×34.5 | J7 | 1250 | 18×34.5 | K7 | 1200 | |
| 1500 | 18×34.5 | K7 | 1500 | 18×43 | K9 | 1550 | |
| 2200 | 18×38.5 | K8 | 1700 | — | — | — | |

(Note) Rated ripple current : 150°C , 100kHz

Low Leakage Current Capacitors

GREEN CAP

• Low leakage current (after 1 minute) : 0.006CV or 0.5 (µA).

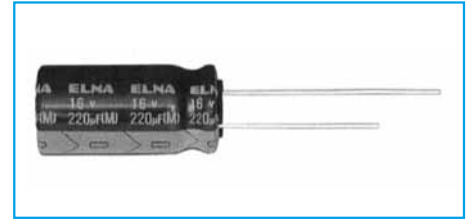

Marking color : White print on a blue sleeve

Specifications

| Item | Performance | |
|--|--|--|
| Category temperature range (°C) | -40 to +85 | |
| Tolerance at rated capacitance (%) | ±20 (20°C, 120Hz) | |
| Leakage current (µA) | Less than 0.006CV or 0.5 whichever is larger (after 1 minute) Less than 0.002CV or 0.3 whichever is larger (after 2 minutes), C : Rated capacitance (µF) ; V : Rated voltage (V) (20°C) | |
| Tangent of loss angle (tanδ) | Rated voltage (V) | 6.3 10 16 25 35 50 |
| | tanδ (max.) | More than 1µF 0.20 0.17 0.13 0.10 0.10 0.08 1µF or less 0.06 0.06 0.06 0.06 0.06 0.06 |
| Characteristics at high and low temperature | Rated voltage (V) | 6.3 10 16 25 35 50 |
| | Impedance ratio (max.) | Z-25°C/Z+20°C 4 3 2 2 2 2 Z-40°C/Z+20°C 8 6 4 4 3 3 |
| Endurance (85°C) (Applied ripple current) | Test time | 1000 hours |
| | Leakage current | The initial specified value or less |
| | Percentage of capacitance change | Within ±20% of initial value |
| | Tangent of the loss angle | 150% or less of the initial specified value |
| Shelf life (85°C) | Test time : 1000 hours ; other items are the same as those for the endurance. Voltage application treatment | |
| Applicable standards | JIS C5101-1, -4 1998 (IEC 60384-1 1992, -4 1985) | |

Outline Drawing

Unit : mm

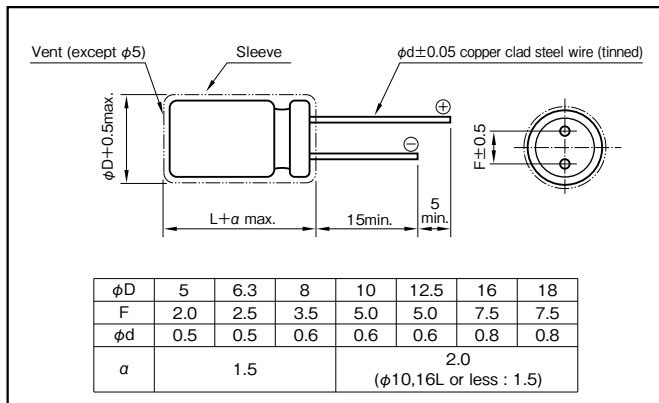

Coefficient of Frequency for Rated Ripple Current

| Rated voltage (V) | Frequency (Hz) CV (µF×V) | 50 · 60 | 120 | 1k | 10k · 100k |
|-------------------|-----------------------------|-----------|--------------|-----|------------|
| | | 6.3 to 10 | All CV value | 0.8 | 1 |
| 16 to 25 | ≤ 1000 | 0.8 | 1 | 1.5 | 1.7 |
| | 1000 < | 0.8 | 1 | 1.2 | 1.3 |
| 35 to 50 | All CV value | 0.8 | 1 | 1.6 | 1.9 |

Part numbering system (example : 10V1000µF)

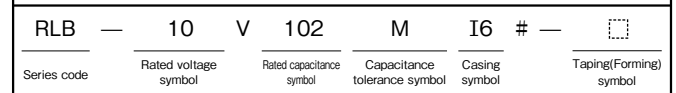

Casing symbol

| Case φD×L (mm) | Casing symbol | Case φD×L (mm) | Casing symbol | Case φD×L (mm) | Casing symbol | Case φD×L (mm) | Casing symbol |
|----------------|---------------|----------------|---------------|----------------|---------------|----------------|---------------|
| 5×11 | E3 | 10×12.5 | H3 | 12.5×20 | I5 | 16×31.5 | J7 |
| 6.3×11 | F3 | 10×16 | H4 | 12.5×25 | I6 | 16×35.5 | J8 |
| 8×11.5 | G3 | 10×20 | H5 | 16×25 | J6 | 18×35.5 | K8 |
| | | | | | | 18×40 | K9 |

Standard Ratings

| Rated capacitance (µF) | 6.3 | | 10 | | 16 | | 25 | | 35 | | 50 | |
|------------------------|----------------|------------------------------|----------------|------------------------------|----------------|------------------------------|----------------|------------------------------|----------------|------------------------------|----------------|------------------------------|
| | Case φD×L (mm) | Rated ripple current (mArms) | Case φD×L (mm) | Rated ripple current (mArms) | Case φD×L (mm) | Rated ripple current (mArms) | Case φD×L (mm) | Rated ripple current (mArms) | Case φD×L (mm) | Rated ripple current (mArms) | Case φD×L (mm) | Rated ripple current (mArms) |
| 1 | — | — | — | — | — | — | — | — | — | — | 5×11 | 20 |
| 2.2 | — | — | — | — | — | — | — | — | — | — | 5×11 | 26 |
| 3.3 | — | — | — | — | — | — | — | — | — | — | 5×11 | 32 |
| 4.7 | — | — | — | — | — | — | 5×11 | 34 | 5×11 | 34 | 6.3×11 | 43 |
| 10 | — | — | — | — | 5×11 | 543 | 6.3×11 | 57 | 6.3×11 | 57 | 8×11.5 | 75 |
| 22 | — | — | 5×11 | 56 | 6.3×11 | 74 | 8×11.5 | 99 | 8×11.5 | 99 | 10×12.5 | 131 |
| 33 | — | — | 6.3×11 | 79 | 6.3×11 | 90 | 8×11.5 | 121 | 10×12.5 | 144 | 10×16 | 176 |
| 47 | — | — | 6.3×11 | 94 | 8×11.5 | 127 | 10×12.5 | 172 | 10×12.5 | 172 | 10×16 | 210 |
| 100 | — | — | 8×11.5 | 160 | 10×12.5 | 220 | 10×16 | 270 | 10×20 | 300 | 12.5×20 | 380 |
| 220 | 10×12.5 | 260 | 10×16 | 350 | 10×20 | 390 | 12.5×20 | 510 | 12.5×25 | 550 | 16×25 | 720 |
| 330 | 10×16 | 350 | 10×20 | 460 | 12.5×20 | 550 | 12.5×25 | 680 | 16×25 | 790 | 16×31.5 | 970 |
| 470 | 10×20 | 460 | 12.5×20 | 570 | 12.5×25 | 650 | 16×25 | 940 | 16×25 | 940 | 16×35.5 | 1210 |
| 1000 | 12.5×25 | 840 | 12.5×25 | 910 | 16×25 | 1210 | 16×35.5 | 1580 | 18×35.5 | 1690 | — | — |
| 2200 | 16×25 | 1440 | 16×31.5 | 1710 | 18×35.5 | 2200 | — | — | — | — | — | — |

(Note) Rated ripple current : 85°C, 120Hz

NOTE : Design, Specifications are subject to change without notice. It is recommended that you shall obtain technical specifications from ELNA to ensure that the component is suitable for your use.

MEMO

**Large Capacitance
Aluminum Electrolytic Capacitors**

PCB Snap-In Miniaturized Capacitors

GREEN CAP

- 20mm-tall products for every diameter of $\phi 22$ to $\phi 35$ are now offered in series.
- As many as 4 case sizes available for the same rating.



Marking color : White print on a black sleeve

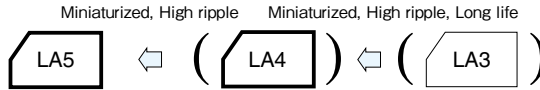

Specifications

| Item | Performance | | | | | | | | | | | | | | | | | | | | | | | | | | | | | | |
|--|--|---|-------------------|-------------------|------------|------------|------------|-----------|---------------------|------|----------|-----------|------------|------------|------|--|---------------|---|---|---|---|---|---|--|---------------|----|----|----|---|---|---|
| Category temperature range (°C) | -40 to +85 (450V is at -25 to +85) | | | | | | | | | | | | | | | | | | | | | | | | | | | | | | |
| Tolerance at rated capacitance (%) | ± 20 (20°C, 120Hz) | | | | | | | | | | | | | | | | | | | | | | | | | | | | | | |
| Leakage current (μA) | Less than 0.01CV or 1.5mA whichever is smaller (after 5 minutes) C : Rated capacitance (μF) ; V : Rated voltage (V) (20°C) | | | | | | | | | | | | | | | | | | | | | | | | | | | | | | |
| Tangent of loss angle ($\tan\delta$) | <table border="1"> <tr> <th>Rated voltage (V)</th> <td>10</td> <td>16</td> <td>25</td> <td>35</td> <td>50</td> <td>63 to 100</td> </tr> <tr> <th>$\tan\delta$ (max.)</th> <td>0.80</td> <td>0.60</td> <td>0.50</td> <td>0.40</td> <td>0.30</td> <td>0.20</td> </tr> </table> | Rated voltage (V) | 10 | 16 | 25 | 35 | 50 | 63 to 100 | $\tan\delta$ (max.) | 0.80 | 0.60 | 0.50 | 0.40 | 0.30 | 0.20 | | | | | | | | | | | | | | | | |
| | Rated voltage (V) | 10 | 16 | 25 | 35 | 50 | 63 to 100 | | | | | | | | | | | | | | | | | | | | | | | | |
| $\tan\delta$ (max.) | 0.80 | 0.60 | 0.50 | 0.40 | 0.30 | 0.20 | | | | | | | | | | | | | | | | | | | | | | | | | |
| | <table border="1"> <tr> <th rowspan="2">$\tan\delta$ (max.)</th> <th rowspan="2">ϕD (mm)</th> <th colspan="2">Rated voltage (V)</th> </tr> <tr> <th>160 to 250</th> <th>315 to 450</th> </tr> <tr> <td></td> <td>22 to 30</td> <td>0.10</td> <td>0.15</td> </tr> <tr> <td></td> <td>35</td> <td>0.15</td> <td>0.15</td> </tr> </table> <p>(20°C, 120Hz)</p> | $\tan\delta$ (max.) | ϕD (mm) | Rated voltage (V) | | 160 to 250 | 315 to 450 | | 22 to 30 | 0.10 | 0.15 | | 35 | 0.15 | 0.15 | | | | | | | | | | | | | | | | |
| $\tan\delta$ (max.) | ϕD (mm) | | | Rated voltage (V) | | | | | | | | | | | | | | | | | | | | | | | | | | | |
| | | 160 to 250 | 315 to 450 | | | | | | | | | | | | | | | | | | | | | | | | | | | | |
| | 22 to 30 | 0.10 | 0.15 | | | | | | | | | | | | | | | | | | | | | | | | | | | | |
| | 35 | 0.15 | 0.15 | | | | | | | | | | | | | | | | | | | | | | | | | | | | |
| Characteristics at high and low temperature | <table border="1"> <tr> <th rowspan="2">Impedance ratio (max.)</th> <th colspan="7">Rated voltage (V)</th> </tr> <tr> <th>10</th> <th>16 to 35</th> <th>50 to 100</th> <th>160 to 200</th> <th>250 to 400</th> <th>450</th> </tr> <tr> <td></td> <td>Z-25°C/Z+20°C</td> <td>5</td> <td>4</td> <td>3</td> <td>3</td> <td>4</td> <td>4</td> </tr> <tr> <td></td> <td>Z-40°C/Z+20°C</td> <td>18</td> <td>15</td> <td>10</td> <td>6</td> <td>8</td> <td>—</td> </tr> </table> <p>(120Hz)</p> | Impedance ratio (max.) | Rated voltage (V) | | | | | | | 10 | 16 to 35 | 50 to 100 | 160 to 200 | 250 to 400 | 450 | | Z-25°C/Z+20°C | 5 | 4 | 3 | 3 | 4 | 4 | | Z-40°C/Z+20°C | 18 | 15 | 10 | 6 | 8 | — |
| | Impedance ratio (max.) | | Rated voltage (V) | | | | | | | | | | | | | | | | | | | | | | | | | | | | |
| 10 | | 16 to 35 | 50 to 100 | 160 to 200 | 250 to 400 | 450 | | | | | | | | | | | | | | | | | | | | | | | | | |
| | Z-25°C/Z+20°C | 5 | 4 | 3 | 3 | 4 | 4 | | | | | | | | | | | | | | | | | | | | | | | | |
| | Z-40°C/Z+20°C | 18 | 15 | 10 | 6 | 8 | — | | | | | | | | | | | | | | | | | | | | | | | | |
| Endurance (85°C) (Applied ripple current) | Test time | 2000 hours | | | | | | | | | | | | | | | | | | | | | | | | | | | | | |
| | Leakage current | The initial specified value or less | | | | | | | | | | | | | | | | | | | | | | | | | | | | | |
| | Percentage of capacitance change | Within $\pm 20\%$ of initial value | | | | | | | | | | | | | | | | | | | | | | | | | | | | | |
| | Tangent of the loss angle | 200% or less of the initial specified value | | | | | | | | | | | | | | | | | | | | | | | | | | | | | |
| Shelf life (85°C) | Test time | 1000 hours | | | | | | | | | | | | | | | | | | | | | | | | | | | | | |
| | Leakage current | The initial specified value or less | | | | | | | | | | | | | | | | | | | | | | | | | | | | | |
| | Percentage of capacitance change | Within $\pm 15\%$ of initial value | | | | | | | | | | | | | | | | | | | | | | | | | | | | | |
| | Tangent of the loss angle | 150% or less of the initial specified value | | | | | | | | | | | | | | | | | | | | | | | | | | | | | |
| Voltage application treatment | | | | | | | | | | | | | | | | | | | | | | | | | | | | | | | |
| Applicable standards | JIS C5101-1, -4 1998 (IEC 60384-1 1992, -4 1985) | | | | | | | | | | | | | | | | | | | | | | | | | | | | | | |

Outline Drawing

Unit : mm

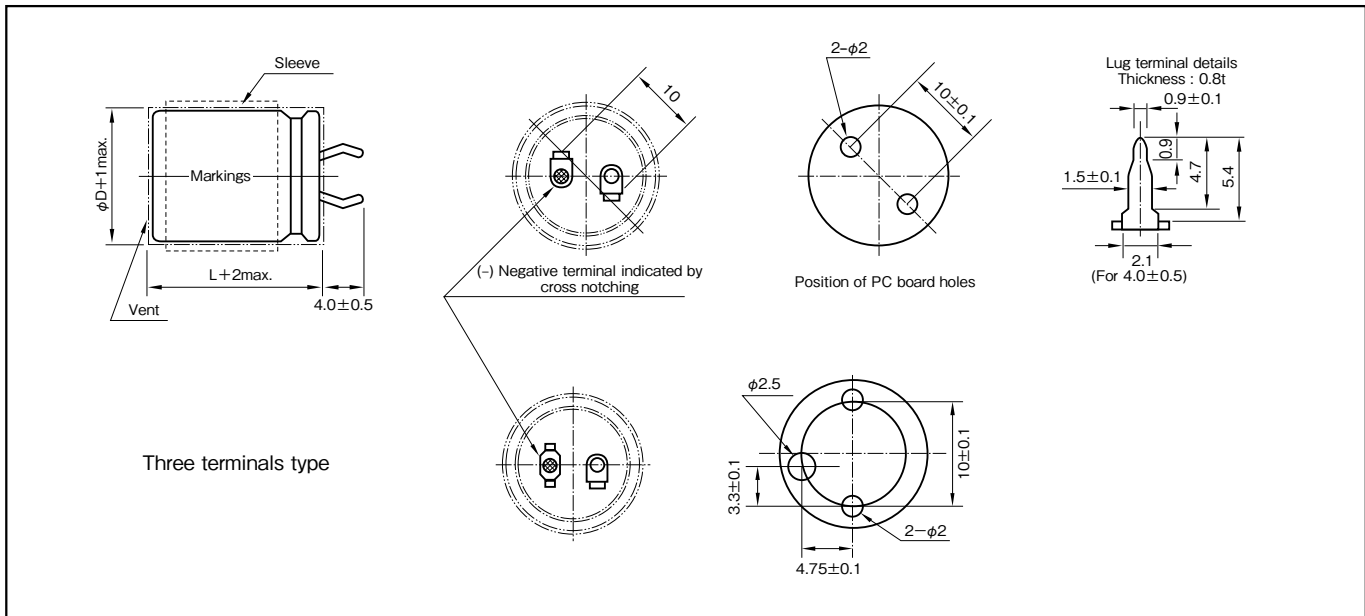

| Part numbering system | | | | | |
|--|----------------------|--------------------------|------------------------------|---------------|-----------------|
| series LA5, standard terminal type : 400V220 μF | | | | | |
| LA5 | 400 | V | 221 | M | S43 # B |
| Series code | Rated voltage symbol | Rated capacitance symbol | Capacitance tolerance symbol | Casing symbol | Optional symbol |
| series LT5, three terminals type : 400V220 μF | | | | | |
| LT5 | — | 400 | V | 221 | M S43 # B |
| Series code | Rated voltage symbol | Rated capacitance symbol | Capacitance tolerance symbol | Casing symbol | Optional symbol |

Coefficient of Frequency for Rated Ripple Current

| Rated voltage (V) | Frequency (Hz) | | | | |
|-------------------|----------------|-----|------|------|------|
| | 50 | 120 | 1k | 10k | 20k |
| 100 or less | 0.95 | 1 | 1.10 | 1.15 | 1.15 |
| 160 to 250 | 0.87 | 1 | 1.11 | 1.18 | 1.20 |
| 315 or more | 0.80 | 1 | 1.14 | 1.19 | 1.20 |

NOTE : Design, Specifications are subject to change without notice. It is recommended that you shall obtain technical specifications from ELNA to ensure that the component is suitable for your use.

Standard Ratings

| Case dDxL (mm) | Casing symbol | 10 | | | 16 | | | 25 | | | 35 | | | 50 | | | 63 | | | 80 | | | 100 | | | | |
|-------------------|------------------|------------------------------|------------|--------------------------------------|------------------------------|------------|--------------------------------------|------------------------------|------------|--------------------------------------|------------------------------|------------|--------------------------------------|------------------------------|------------|--------------------------------------|------------------------------|------------|--------------------------------------|------------------------------|------------|--------------------------------------|------------------------------|------------|--------------------------------------|-------|-----|
| | | Rated capacitance (μF) | ESR (Ω) | Rated ripple current (Arms) | Rated capacitance (μF) | ESR (Ω) | Rated ripple current (Arms) | Rated capacitance (μF) | ESR (Ω) | Rated ripple current (Arms) | Rated capacitance (μF) | ESR (Ω) | Rated ripple current (Arms) | Rated capacitance (μF) | ESR (Ω) | Rated ripple current (Arms) | Rated capacitance (μF) | ESR (Ω) | Rated ripple current (Arms) | Rated capacitance (μF) | ESR (Ω) | Rated ripple current (Arms) | Rated capacitance (μF) | ESR (Ω) | Rated ripple current (Arms) | | |
| 22x20 | S21 | 8200 | 0.101 | 2.0 | 5600 | 0.118 | 1.9 | 3900 | 0.128 | 1.8 | 2700 | 0.154 | 1.6 | 1800 | 0.184 | 1.6 | 1500 | 0.166 | 1.7 | 1000 | 0.249 | 1.5 | 560 | 0.444 | 1.3 | | |
| 22x25 | S22 | 12000 | 0.069 | 2.5 | 8200 | 0.081 | 2.4 | 5600 | 0.089 | 2.3 | 3900 | 0.106 | 2.1 | 2700 | 0.123 | 2.1 | 2200 | 0.113 | 2.2 | 1500 | 0.166 | 1.9 | 820 | 0.303 | 1.7 | | |
| 22x30 | S23 | 15000 | 0.055 | 3.0 | 12000 | 0.055 | 3.0 | 8200 | 0.061 | 2.8 | 4700 | 0.088 | 2.4 | 3900 | 0.085 | 2.6 | 2700 | 0.092 | 2.5 | 1800 | 0.138 | 2.2 | 1200 | 0.207 | 2.1 | | |
| 22x35 | S24 | 22000 | 0.038 | 3.7 | 15000 | 0.044 | 3.4 | 10000 | 0.050 | 3.2 | 6800 | 0.061 | 2.9 | 4700 | 0.071 | 3.1 | 3300 | 0.075 | 2.9 | 2200 | 0.113 | 2.5 | 1500 | 0.166 | 2.5 | | |
| 22x40 | S25 | — | — | — | 18000 | 0.037 | 3.9 | 12000 | 0.041 | 3.7 | 8200 | 0.051 | 3.3 | 5600 | 0.059 | 3.4 | 3900 | 0.064 | 3.3 | 2700 | 0.092 | 2.8 | 1800 | 0.138 | 2.8 | | |
| 22x45 | S26 | 27000 | 0.031 | 4.3 | — | — | — | — | — | — | — | — | — | — | — | — | 4700 | 0.053 | 3.7 | 3300 | 0.075 | 3.2 | 2200 | 0.113 | 3.2 | | |
| 22x50 | S27 | 33000 | 0.025 | 4.9 | 22000 | 0.030 | 4.5 | 15000 | 0.033 | 4.3 | 10000 | 0.041 | 3.9 | 6800 | 0.049 | 3.9 | 5600 | 0.044 | 4.1 | 3900 | 0.064 | 3.6 | — | — | — | | |
| 25x20 | S31 | 12000 | 0.069 | 2.5 | 8200 | 0.081 | 2.4 | 5600 | 0.089 | 2.2 | 3900 | 0.106 | 2.0 | 2700 | 0.123 | 2.1 | 1800 | 0.138 | 2.0 | 1200 | 0.207 | 1.7 | 820 | 0.303 | 1.7 | | |
| 25x25 | S32 | 18000 | 0.046 | 3.2 | 12000 | 0.055 | 2.9 | 8200 | 0.061 | 2.8 | 5600 | 0.074 | 2.6 | 3900 | 0.085 | 2.6 | 2700 | 0.092 | 2.0 | 1800 | 0.138 | 2.2 | 1200 | 0.207 | 2.1 | | |
| 25x30 | S33 | 22000 | 0.038 | 3.7 | 15000 | 0.044 | 3.4 | 10000 | 0.050 | 3.2 | 6800 | 0.061 | 2.9 | 4700 | 0.071 | 3.0 | 3900 | 0.064 | 3.2 | 2200 | 0.113 | 2.5 | 1500 | 0.166 | 2.5 | | |
| 25x35 | S34 | 27000 | 0.031 | 4.2 | 18000 | 0.037 | 3.9 | 12000 | 0.041 | 3.7 | 8200 | 0.051 | 3.3 | 5600 | 0.059 | 3.4 | 4700 | 0.053 | 3.6 | 3300 | 0.075 | 3.1 | 1800 | 0.138 | 2.8 | | |
| 25x40 | S35 | 33000 | 0.025 | 4.8 | 22000 | 0.030 | 4.4 | 15000 | 0.033 | 4.2 | 10000 | 0.041 | 3.8 | 6800 | 0.049 | 3.8 | 5600 | 0.044 | 4.0 | 3900 | 0.064 | 3.5 | 2200 | 0.113 | 3.2 | | |
| 25x45 | S36 | 39000 | 0.021 | 5.4 | 27000 | 0.025 | 5.0 | 18000 | 0.028 | 4.7 | 12000 | 0.035 | 4.3 | 8200 | 0.040 | 4.3 | 6800 | 0.037 | 4.6 | — | — | — | 2700 | 0.092 | 2.9 | | |
| 25x50 | S37 | 47000 | 0.018 | 6.0 | — | — | — | 22000 | 0.023 | 5.4 | 15000 | 0.028 | 4.9 | 10000 | 0.033 | 4.9 | — | — | — | 4700 | 0.053 | 4.0 | 3300 | 0.075 | 4.1 | | |
| 30x20 | S41 | 18000 | 0.046 | 3.3 | 12000 | 0.055 | 3.0 | 8200 | 0.061 | 2.9 | 5600 | 0.074 | 2.6 | 3900 | 0.085 | 2.7 | 2700 | 0.092 | 2.6 | 1800 | 0.138 | 2.2 | 1200 | 0.207 | 2.2 | | |
| 30x25 | S42 | 27000 | 0.031 | 4.2 | 18000 | 0.037 | 3.9 | 12000 | 0.041 | 3.7 | 8200 | 0.051 | 3.3 | 5600 | 0.059 | 3.4 | 3900 | 0.064 | 3.3 | 2700 | 0.092 | 2.9 | 1800 | 0.138 | 2.8 | | |
| 30x30 | S43 | 33000 | 0.025 | 4.9 | 22000 | 0.030 | 4.4 | 15000 | 0.033 | 4.3 | 10000 | 0.041 | 3.8 | 6800 | 0.049 | 3.9 | 5600 | 0.044 | 4.1 | 3900 | 0.064 | 3.6 | 2200 | 0.113 | 3.2 | | |
| 30x35 | S44 | 39000 | 0.021 | 5.5 | 27000 | 0.025 | 5.1 | 18000 | 0.028 | 4.8 | 12000 | 0.035 | 4.3 | 8200 | 0.040 | 4.4 | 6800 | 0.037 | 4.6 | 4700 | 0.053 | 4.0 | 2700 | 0.092 | 3.7 | | |
| 30x40 | S45 | 47000 | 0.018 | 6.1 | 33000 | 0.020 | 5.8 | 22000 | 0.023 | 5.5 | 15000 | 0.028 | 5.0 | 10000 | 0.033 | 5.0 | 8200 | 0.030 | 5.2 | 5600 | 0.044 | 4.5 | 3300 | 0.075 | 4.2 | | |
| 30x45 | S46 | 56000 | 0.015 | 6.9 | 39000 | 0.017 | 6.4 | 27000 | 0.018 | 6.2 | 18000 | 0.023 | 5.6 | 12000 | 0.028 | 5.6 | 10000 | 0.025 | 5.9 | 6800 | 0.037 | 5.1 | 3900 | 0.064 | 4.7 | | |
| 30x50 | S47 | 68000 | 0.012 | 7.7 | 47000 | 0.014 | 7.2 | 33000 | 0.015 | 7.0 | 22000 | 0.019 | 6.3 | 15000 | 0.022 | 6.4 | — | — | — | — | — | — | 4700 | 0.053 | 5.2 | | |
| 35x20 | S51 | 22000 | 0.038 | 3.9 | 15000 | 0.044 | 3.7 | 10000 | 0.050 | 3.5 | 6800 | 0.061 | 3.1 | 4700 | 0.071 | 3.2 | 3900 | 0.064 | 3.4 | 2700 | 0.092 | 3.0 | 1500 | 0.166 | 2.7 | | |
| 35x25 | S52 | 33000 | 0.025 | 5.0 | 22000 | 0.030 | 4.6 | 15000 | 0.033 | 4.4 | 10000 | 0.041 | 4.0 | 6800 | 0.049 | 4.0 | 5600 | 0.044 | 4.2 | 3900 | 0.064 | 3.7 | 2200 | 0.113 | 3.4 | | |
| 35x30 | S53 | 47000 | 0.018 | 6.2 | 33000 | 0.020 | 5.8 | 22000 | 0.023 | 5.5 | 15000 | 0.028 | 5.0 | 10000 | 0.033 | 5.0 | 8200 | 0.030 | 5.2 | 5600 | 0.044 | 4.5 | 3300 | 0.075 | 4.3 | | |
| 35x35 | S54 | 56000 | 0.015 | 7.0 | 39000 | 0.017 | 6.5 | 27000 | 0.018 | 6.2 | 18000 | 0.023 | 5.7 | 12000 | 0.028 | 5.7 | 8200 | 0.030 | 5.5 | 5600 | 0.044 | 4.7 | 3900 | 0.064 | 4.4 | | |
| 35x40 | S55 | 68000 | 0.012 | 7.9 | 47000 | 0.014 | 7.4 | 33000 | 0.015 | 7.2 | 22000 | 0.019 | 6.4 | 15000 | 0.022 | 6.5 | 10000 | 0.025 | 6.2 | 6800 | 0.037 | 5.3 | 4700 | 0.053 | 5.4 | | |
| 35x45 | S56 | 82000 | 0.010 | 8.9 | 56000 | 0.012 | 8.2 | 39000 | 0.013 | 8.0 | — | — | — | — | — | 18000 | 0.018 | 7.3 | 12000 | 0.021 | 6.9 | 8200 | 0.030 | 6.0 | 5600 | 0.044 | 6.0 |
| 35x50 | S57 | — | — | — | — | — | — | — | — | — | 27000 | 0.015 | 7.4 | — | — | — | 15000 | 0.017 | 7.9 | 10000 | 0.025 | 6.8 | — | — | — | | |

| Case dDxL (mm) | Casing symbol | 160 | | | 180 | | | 200 | | | 250 | | | 315 | | | 350 | | | 400 | | | 450 | | |
|-------------------|------------------|------------------------------|------------|--------------------------------------|------------------------------|------------|--------------------------------------|------------------------------|------------|--------------------------------------|------------------------------|------------|--------------------------------------|------------------------------|------------|--------------------------------------|------------------------------|------------|--------------------------------------|------------------------------|------------|--------------------------------------|------------------------------|------------|--------------------------------------|
| | | Rated capacitance (μF) | ESR (Ω) | Rated ripple current (Arms) | Rated capacitance (μF) | ESR (Ω) | Rated ripple current (Arms) | Rated capacitance (μF) | ESR (Ω) | Rated ripple current (Arms) | Rated capacitance (μF) | ESR (Ω) | Rated ripple current (Arms) | Rated capacitance (μF) | ESR (Ω) | Rated ripple current (Arms) | Rated capacitance (μF) | ESR (Ω) | Rated ripple current (Arms) | Rated capacitance (μF) | ESR (Ω) | Rated ripple current (Arms) | Rated capacitance (μF) | ESR (Ω) | Rated ripple current (Arms) |
| 22x20 | S21 | 270 | 0.614 | 1.2 | 220 | 0.754 | 1.1 | 180 | 0.922 | 1.0 | 150 | 1.106 | 0.94 | 100 | 2.488 | 0.78 | 68 | 3.659 | 0.61 | 56 | 4.443 | 0.54 | 47 | 5.294 | 0.49 |
| 22x25 | S22 | 390 | 0.425 | 1.5 | 330 | 0.503 | 1.4 | 270 | 0.614 | 1.3 | 220 | 0.754 | 1.2 | 150 | 1.659 | 1.0 | 100 | 2.488 | 0.78 | 82 | 3.034 | 0.69 | 68 | 3.659 | 0.62 |
| 22x30 | S23 | 560 | 0.296 | 1.9 | 470 | 0.353 | 1.8 | 390 | 0.425 | 1.6 | 270 | 0.614 | 1.4 | 180 | 1.382 | 1.1 | 150 | 1.659 | 1.0 | 120 | 2.073 | 0.86 | 82 | 3.034 | 0.71 |
| 22x35 | S24 | 680 | 0.244 | 2.2 | 560 | 0.296 | 2.0 | 470 | 0.353 | 1.9 | 330 | 0.503 | 1.6 | 220 | 1.131 | 1.3 | 180 | 1.382 | 1.1 | 150 | 1.659 | 1.0 | 100 | 2.488 | 0.82 |
| 22x40 | S25 | 820 | 0.202 | 2.5 | 680 | 0.244 | 2.3 | 560 | 0.296 | 2.1 | 390 | 0.425 | 1.8 | 270 | 0.922 | 1.5 | 220 | 1.131 | 1.3 | 180 | 1.382 | 1.1 | 120 | 2.073 | 0.92 |
| 22x45 | S26 | — | — | — | 820 | 0.202 | 2.6 | 680 | 0.244 | 2.4 | 470 | 0.353 | 2.0 | 330 | 0.754 | 1.7 | — | — | — | 220 | 1.131 | 1.3 | 150 | 1.659 | 1.1 |
| 22x50 | S27 | 1000 | 0.166 | 2.9 | — | — | — | 820 | 0.202 | 2.6 | 560 | 0.296 | 2.2 | — | — | — | 270 | 0.922 | 1.5 | — | — | — | 180 | 1.382 | 1.2 |
| 25x20 | S31 | 390 | 0.425 | 1.5 | 330 | 0.503 | 1.4 | 270 | 0.614 | 1.3 | 180 | 0.922 | 1.1 | 120 | 2.073 | 0.88 | 100 | 2.488 | 0.77 | 82 | 3.034 | 0.69 | 56 | 4.443 | 0.57 |
| 25x25 | S32 | 560 | 0.296 | 1.9 | 470 | 0.353 | 1.8 | 390 | 0.425 | 1.6 | 270 | 0.614 | 1.4 | 180 | 1.382 | 1.1 | 150 | 1.659 | 0.99 | 120 | 2.073 | 0.87 | 82 | 3.034 | 0.72 |
| 25x30 | S33 | 680 | 0.244 | 2.2 | 560 | 0.296 | 2.0 | 560 | 0.296 | 2.0 | 390 | 0.425 | 1.7 | 270 | 0.922 | 1.4 | 180 | 1.382 | 1.1 | 150 | 1.659 | 1.0 | 120 | 2.073 | 0.91 |
| 25x35 | S34 | 820 | 0.202 | 2.5 | 680 | 0.244 | 2.3 | 680 | 0.244 | 2.3 | 470 | 0.353 | 2.0 | 330 | 0.754 | 1.7 | 220 | 1.131 | 1.3 | 180 | 1.382 | 1.1 | 150 | 1.659 | 1.0 |
| 25x40 | S35 | 1000 | 0.166 | 2.8 | 820 | 0.202 | 2.6 | 820 | 0.202 | 2.6 | 560 | 0.296 | 2.2 | 390 | 0.638 | 1.8 | 270 | 0.922 | 1.5 | 220 | 1.131 | 1.3 | 180 | 1.382 | 1.2 |
| 25x45 | S36 | 1200 | 0.138 | 3.2 | 1000 | 0.166 | 2.9 | — | — | — | 680 | 0.244 | 2.5 | — | — | — | 330 | 0.754 | 1.7 | 270 | 0.922 | 1.5 | — | — | — |
| 25x50 | S37 | 1500 | 0.111 | 3.6 | 1200 | 0.138 | 3.3 | 1000 | 0.166 | 3.0 | — | — | — | 470 | 0.529 | 2.1 | 390 | 0.638 | 1.9 | 330 | 0.754 | 1.7 | 220 | 1.131 | 1.4 |
| 30x20 | S41 | 560 | 0.296 | 2.0 | 470 | 0.353 | 1.8 | 390 | 0.425 | 1.7 | 270 | 0.614 | 1.4 | 180 | 1.382 | 1.2 | 150 | 1.659 | 1.0 | 120 | 2.073 | 0.93 | 82 | 3.034 | 0.77 |
| 30x25 | S42 | 820 | 0.202 | 2.5 | 680 | 0.244 | 2.3 | 560 | 0.296 | 2.1 | 390 | 0.425 | 1.8 | 270 | 0.922 | 1.5 | 220 | 1.131 | 1.3 | 180 | 1.382 | 1.2 | 120 | 2.073 | 0.97 |
| 30x30 | S43 | 1000 | 0.166 | 2.9 | 820 | 0.202 | 2.6 | 820 | 0.202 | 2.7 | 560 | 0.296 | 2.3 | 390 | 0.638 | 1.9 | 270 | 0.922 | 1.5 | 220 | 1.131 | 1.4 | 180 | 1.382 | 1.2 |
| 30x35 | S44 | 1200 | 0.138 | 3.3 | 1200 | 0.138 | 3.3 | 1000 | 0.166 | 3.0 | 680 | 0.244 | 2.6 | 470 | 0.529 | 2.1 | 330 | 0.754 | 1.7 | 270 | 0.922 | 1.6 | 220 | 1.131 | 1.4 |
| 30x40 | S45 | 1500 | 0.111 | 3.7 | — | — | — | 1200 | 0.138 | 3.4 | 820 | 0.202 | 2.9 | 560 | 0.444 | 2.4 | 390 | 0.638 | 1.9 | 330 | 0.754 | 1.8 | 270 | 0.922 | 1.6 |
| 30x45 | S46 | 1800 | 0.092 | 4.2 | 1500 | 0.111 | 3.9 | — | — | — | 1000 | 0.166 | 3.3 | 680 | 0.366 | 2 | | | | | | | | | |

Ultra Miniaturized, High-Reliability, High-Ripple Capacitors

GREEN CAP 105°C 2000hours

- Best suited as input filters for various power supplies.
- Guarantees 2000 hours at 105°C.



Marking color : White print on a black sleeve

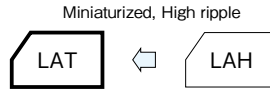

Specifications

| Item | Performance | |
|---|--|---|
| Category temperature range (°C) | -25 to +105 | |
| Tolerance at rated capacitance (%) | ±20 (20°C, 120Hz) | |
| Leakage current (μA) | Less than 0.02CV or 3mA whichever is smaller (after 5 minutes) C : Rated capacitance (μF) ; V : Rated voltage (V) (20°C) | |
| Tangent of loss angle (tanδ) | Rated voltage (V) | 160 to 250 |
| | tanδ (max.) | 0.15 |
| Characteristics at high and low temperature | Percentage of capacitance change (%) | Within ±30% of the value at 20°C |
| | Impedance ratio (max.) | 4 (120Hz) |
| Endurance (105°C) (Applied ripple current) | Test time | 2000 hours |
| | Leakage current | The initial specified value or less |
| | Percentage of capacitance change | Within ±20% of initial value |
| | Tangent of the loss angle | 200% or less of the initial specified value |
| Shelf life (105°C) | Test time | 1000 hours |
| | Leakage current | The initial specified value or less |
| | Percentage of capacitance change | Within ±15% of initial value |
| | Tangent of the loss angle | 150% or less of the initial specified value |
| Applicable standards | Voltage application treatment JIS C5101-1, -4 1998 (IEC 60384-1 1992, -4 1985) | |

Outline Drawing

Unit : mm

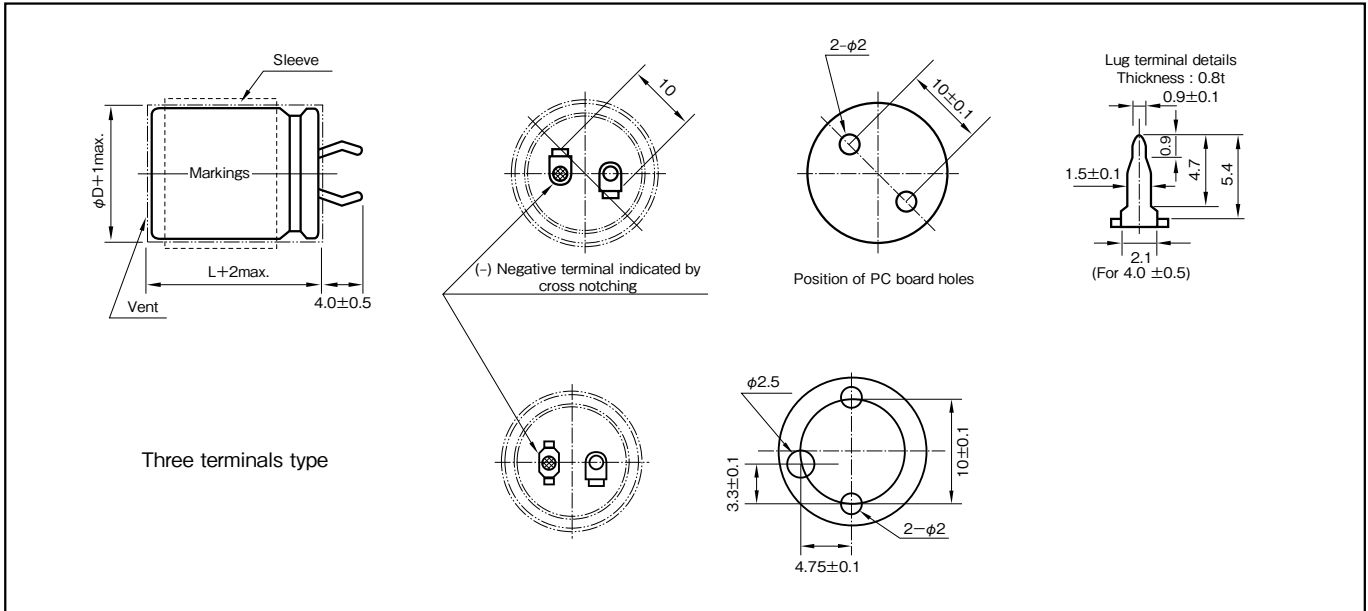

| Part numbering system | | | | | |
|---|----------------------|--------------------------|------------------------------|---------------|-----------------|
| series LAT, standard terminal type :400V220μF | | | | | |
| LAT | — 400 V | 221 | M | S52 # | B |
| Series code | Rated voltage symbol | Rated capacitance symbol | Capacitance tolerance symbol | Casing symbol | Optional symbol |
| series LTT, three terminals type :400V220μF | | | | | |
| LTT | — 400 V | 221 | M | S52 # | B |
| Series code | Rated voltage symbol | Rated capacitance symbol | Capacitance tolerance symbol | Casing symbol | Optional symbol |

Coefficient of Frequency for Rated Ripple Current

| Rated voltage (V) | Frequency (Hz) | | | | |
|-------------------|----------------|-----|------|------|------|
| | 50 | 120 | 1k | 10k | 30k |
| 160 to 250 | 0.87 | 1 | 1.11 | 1.18 | 1.20 |
| 315 or more | 0.80 | 1 | 1.14 | 1.19 | 1.20 |

• The electric characteristics are described on page 185.

Standard Ratings

| Rated voltage(V) Case φD×L(mm) | | Item Casing symbol | 160 | | 200 | | 250 | | 315 | | 350 | |
|--------------------------------------|-----|--------------------------|---------------------------|--------------------------------|---------------------------|--------------------------------|---------------------------|--------------------------------|---------------------------|--------------------------------|---------------------------|--------------------------------|
| | | | Rated capacitance (μF) | Rated ripple current (Arms) | Rated capacitance (μF) | Rated ripple current (Arms) | Rated capacitance (μF) | Rated ripple current (Arms) | Rated capacitance (μF) | Rated ripple current (Arms) | Rated capacitance (μF) | Rated ripple current (Arms) |
| 22×20 | S21 | 220 | 0.70 | 150 | 0.58 | 120 | 0.52 | 68 | 0.39 | 56 | 0.35 | |
| 22×25 | S22 | 390 | 1.30 | 330 | 1.22 | 270 | 1.11 | 120 | 0.75 | 100 | 0.51 | |
| 22×30 | S23 | 470 | 1.47 | 470 | 1.44 | 330 | 1.26 | 150 | 0.82 | 120 | 0.61 | |
| 22×35 | S24 | 560 | 1.58 | 560 | 1.64 | 390 | 1.37 | 180 | 0.91 | 150 | 0.73 | |
| 22×40 | S25 | 680 | 1.71 | 680 | 1.72 | 470 | 1.64 | 220 | 1.02 | 180 | 0.84 | |
| 22×45 | S26 | 820 | 2.00 | 820 | 1.91 | 560 | 1.71 | 270 | 1.16 | 220 | 0.98 | |
| 22×50 | S27 | 1000 | 2.20 | 1000 | 2.20 | 680 | 1.84 | 330 | 1.20 | 270 | 1.09 | |
| 25×20 | S31 | 270 | 0.84 | 180 | 0.68 | 150 | 0.62 | 100 | 0.51 | 82 | 0.46 | |
| 25×25 | S32 | 470 | 1.55 | 470 | 1.48 | 390 | 1.42 | 180 | 0.90 | 150 | 0.68 | |
| 25×30 | S33 | 680 | 1.70 | 680 | 1.69 | 470 | 1.55 | 220 | 1.00 | 180 | 0.80 | |
| 25×35 | S34 | 820 | 2.00 | 820 | 1.91 | 560 | 1.71 | 270 | 1.10 | 220 | 0.99 | |
| 25×40 | S35 | 1000 | 2.20 | 1000 | 2.15 | 680 | 1.97 | 330 | 1.20 | 270 | 1.09 | |
| 25×45 | S36 | 1200 | 2.45 | 1200 | 2.47 | 820 | 1.99 | 390 | 1.30 | 330 | 1.20 | |
| 25×50 | S37 | 1500 | 2.86 | — | — | 1000 | 2.23 | 470 | 1.40 | 390 | 1.28 | |
| 30×20 | S41 | 390 | 1.13 | 330 | 1.04 | 220 | 0.92 | 150 | 0.70 | 120 | 0.69 | |
| 30×25 | S42 | 680 | 1.82 | 680 | 1.84 | 390 | 1.31 | 270 | 1.10 | 220 | 0.99 | |
| 30×30 | S43 | 1000 | 2.20 | 820 | 2.00 | 680 | 1.97 | 330 | 1.20 | 270 | 1.09 | |
| 30×35 | S44 | 1200 | 2.44 | 1200 | 2.45 | 820 | 2.20 | 390 | 1.30 | 330 | 1.20 | |
| 30×40 | S45 | 1500 | 2.82 | 1500 | 2.82 | 1200 | 2.61 | 470 | 1.40 | 390 | 1.28 | |
| 30×45 | S46 | 1800 | 3.31 | — | — | — | — | 560 | 1.50 | 470 | 1.37 | |
| 30×50 | S47 | 2200 | 3.81 | 1800 | 3.32 | 1500 | 3.03 | 680 | 1.70 | 560 | 1.54 | |
| 35×20 | S51 | 560 | 1.49 | 470 | 1.37 | 330 | 1.14 | 180 | 0.83 | 150 | 0.76 | |
| 35×25 | S52 | 1000 | 2.20 | 1000 | 2.21 | 560 | 1.68 | 330 | 1.20 | 270 | 1.09 | |
| 35×30 | S53 | 1500 | 2.50 | 1500 | 2.82 | 1000 | 2.12 | 470 | 1.40 | 390 | 1.28 | |
| 35×35 | S54 | 1800 | 2.92 | 1800 | 3.25 | — | — | 560 | 1.50 | 470 | 1.37 | |
| 35×40 | S55 | 2200 | 3.34 | — | — | 1500 | 2.82 | 680 | 1.70 | 560 | 1.54 | |
| 35×45 | S56 | 2200 | 3.48 | 2200 | 3.84 | 1800 | 2.98 | 820 | 2.00 | 680 | 1.82 | |
| 35×50 | S57 | 2700 | 3.97 | 2700 | 4.19 | 2200 | 3.58 | — | — | 820 | 2.08 | |

| Rated voltage(V) Case φD×L(mm) | | Item Casing symbol | 400 | | 450 | | 500 | |
|--------------------------------------|-----|--------------------------|---------------------------|--------------------------------|---------------------------|--------------------------------|---------------------------|--------------------------------|
| | | | Rated capacitance (μF) | Rated ripple current (Arms) | Rated capacitance (μF) | Rated ripple current (Arms) | Rated capacitance (μF) | Rated ripple current (Arms) |
| 22×20 | S21 | 56 | 0.39 | 56 | 0.35 | 22 | 0.24 | |
| | | 68 | 0.43 | — | — | 27 | 0.28 | |
| 22×25 | S22 | 100 | 0.56 | 82 | 0.47 | 33 | 0.32 | |
| | | 120 | 0.61 | 100 | 0.54 | 39 | 0.37 | |
| 22×30 | S23 | 120 | 0.70 | 100 | 0.56 | 47 | 0.41 | |
| | | 150 | 0.72 | 120 | 0.62 | 56 | 0.47 | |
| 22×35 | S24 | 150 | 0.73 | 120 | 0.65 | 68 | 0.54 | |
| | | 220 | 0.88 | 150 | 0.73 | — | — | |
| 22×40 | S25 | 180 | 0.84 | 150 | 0.77 | 82 | 0.62 | |
| | | 270 | 1.03 | 180 | 0.84 | — | — | |
| 22×45 | S26 | 220 | 0.99 | 180 | 0.89 | 100 | 0.67 | |
| | | 270 | 1.10 | 220 | 0.98 | — | — | |
| 22×50 | S27 | 330 | 1.28 | 220 | 1.03 | 120 | 0.77 | |
| | | — | — | 270 | 1.14 | — | — | |
| 25×20 | S31 | 68 | 0.46 | 56 | 0.38 | — | — | |
| | | 82 | 0.51 | — | — | — | — | |
| 25×25 | S32 | 150 | 0.68 | 100 | 0.71 | — | — | |
| | | 180 | 0.74 | 120 | 0.61 | — | — | |
| 25×30 | S33 | 180 | 0.80 | 150 | 0.82 | 68 | 0.54 | |
| | | 220 | 0.88 | 180 | 0.90 | — | — | |
| 25×35 | S34 | 220 | 1.04 | 180 | 0.96 | 82 | 0.62 | |
| | | 270 | 1.10 | 220 | 0.99 | — | — | |
| 25×40 | S35 | 270 | 1.11 | 220 | 1.00 | 100 | 0.67 | |
| | | 330 | 1.23 | 270 | 1.11 | 120 | 0.74 | |
| 25×45 | S36 | 330 | 1.29 | 270 | 1.17 | 150 | 0.82 | |
| | | 390 | 1.40 | — | — | — | — | |
| 25×50 | S37 | 390 | 1.43 | 270 | 1.22 | 180 | 0.98 | |
| | | 470 | 1.57 | 330 | 1.35 | — | — | |
| 30×20 | S41 | 82 | 0.52 | 82 | 0.52 | — | — | |
| | | 100 | 0.57 | 100 | 0.57 | — | — | |
| 30×25 | S42 | 180 | 0.90 | 150 | 0.83 | — | — | |
| | | 270 | 1.05 | 180 | 0.72 | — | — | |
| 30×30 | S43 | 270 | 1.09 | 220 | 1.12 | 100 | 0.67 | |
| | | 330 | 1.21 | 270 | 1.20 | — | — | |
| 30×35 | S44 | 330 | 1.34 | 270 | 1.24 | 120 | 0.77 | |
| | | 390 | 1.47 | 330 | 1.30 | — | — | |
| 30×40 | S45 | 390 | 1.51 | 390 | 1.32 | 150 | 0.85 | |
| | | 470 | 1.60 | — | — | — | — | |
| 30×45 | S46 | 470 | 1.65 | 390 | 1.35 | 180 | 1.01 | |
| | | 560 | 1.80 | 470 | 1.52 | — | — | |
| 30×50 | S47 | 560 | 1.84 | — | — | 220 | 1.12 | |
| | | 680 | 2.03 | — | — | 270 | 1.25 | |
| 35×20 | S51 | 120 | 0.75 | 120 | 0.72 | — | — | |
| | | 150 | 0.84 | 150 | 0.80 | — | — | |
| 35×25 | S52 | 270 | 1.20 | 220 | 1.04 | — | — | |
| | | 330 | 1.33 | 270 | 1.15 | — | — | |
| 35×30 | S53 | 390 | 1.40 | 270 | 1.26 | 120 | 0.80 | |
| | | 470 | 1.50 | 330 | 1.39 | — | — | |
| 35×35 | S54 | 470 | 1.69 | 390 | 1.54 | 150 | 0.85 | |
| | | 560 | 1.80 | — | — | — | — | |
| 35×40 | S55 | 560 | 1.82 | 470 | 1.59 | 220 | 1.12 | |
| | | 680 | 1.90 | — | — | 270 | 1.25 | |
| 35×45 | S56 | 680 | 1.95 | 470 | 1.64 | 330 | 1.36 | |
| | | 820 | 2.14 | 560 | 1.79 | — | — | |
| 35×50 | S57 | — | — | 560 | 2.02 | 390 | 1.54 | |
| | | — | — | 680 | 2.23 | — | — | |

(Note) Rated ripple current : 105°C , 120Hz

NOTE : Design, Specifications are subject to change without notice.
It is recommended that you shall obtain technical specifications from ELNA to ensure that the component is suitable for your use.

Miniaturized, High-Reliability, High-Ripple Capacitors

GREEN CAP 105°C
2000hours

- High-reliability, high-ripple capacitors.
- Guarantees 2000 hours at 105°C.

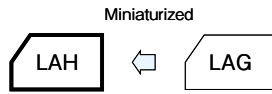

Marking color : White print on a black sleeve

Specifications

| Item | Performance | | | | | | | |
|---|--|---|------|------------|------|------------|------------|------------|
| Category temperature range (°C) | -40 to +105 (-25 to +105 at 160V or more) | | | | | | | |
| Tolerance at rated capacitance (%) | ± 20 (20°C, 120Hz) | | | | | | | |
| Leakage current (μA) | Less than 0.02CV or 3mA whichever is smaller (after 5 minutes) C : Rated capacitance (μF) ; V : Rated voltage (V) (20°C) | | | | | | | |
| Tangent of loss angle (tanδ) | Rated voltage (V) | 16 | 25 | 35 | 50 | 63 to 100 | 160 to 250 | 400 to 450 |
| | tanδ (max.) | 0.50 | 0.40 | 0.35 | 0.30 | 0.20 | 0.15 | 0.20 |
| Characteristics at high and low temperature | Rated voltage (V) | 16 to 100 | | 160 to 200 | | 250 to 400 | | (120Hz) |
| | Impedance ratio (max.) | Z-25°C/Z+20°C | | 4 | | 4 | | |
| Endurance (105°C) (Applied ripple current) | Test time | 2000 hours | | | | | | |
| | Leakage current | The initial specified value or less | | | | | | |
| | Percentage of capacitance change | Within ±20% of initial value | | | | | | |
| | Tangent of the loss angle | 200% or less of the initial specified value | | | | | | |
| Shelf life (105°C) | Test time | 1000 hours | | | | | | |
| | Leakage current | The initial specified value or less | | | | | | |
| | Percentage of capacitance change | Within ±15% of initial value | | | | | | |
| | Tangent of the loss angle | 150% or less of the initial specified value | | | | | | |
| Applicable standards | Voltage application treatment JIS C5101-1, -4 1998 (IEC 60384-1 1992, -4 1985) | | | | | | | |

Outline Drawing

Unit: mm

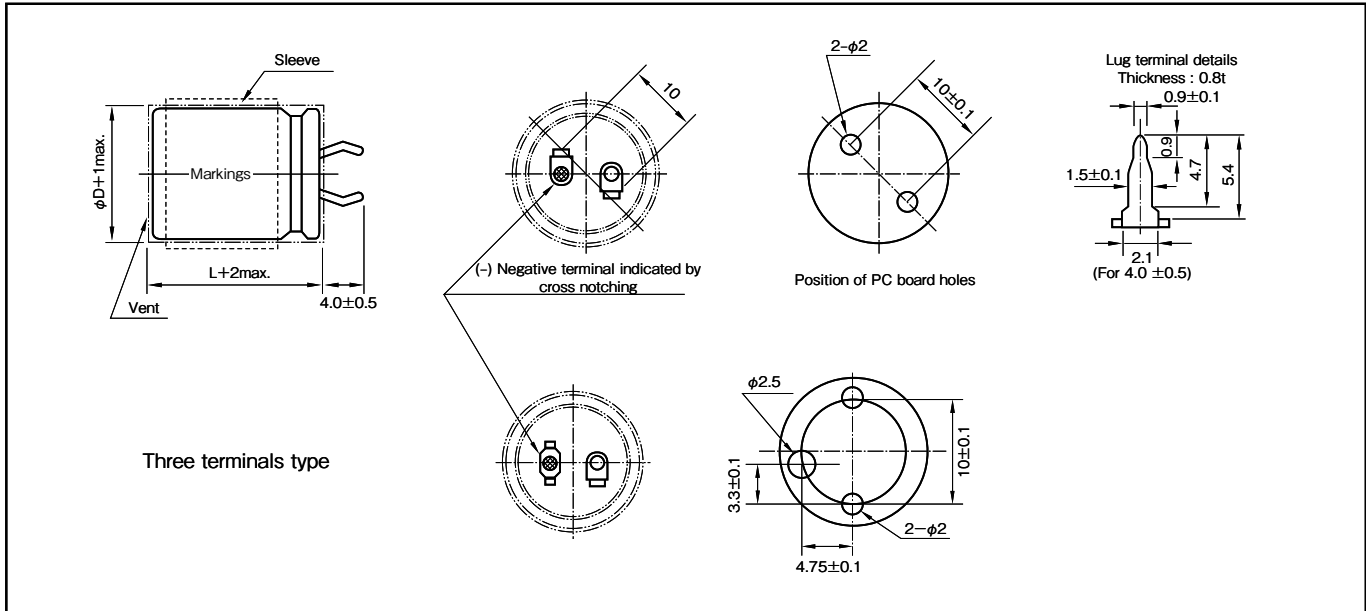

| Part numbering system | | | | | | |
|---|---|----------------------|--------------------------|------------------------------|---------------|-----------------|
| series LAH, standard terminal type :400V330μF | | | | | | |
| LAH | — | 400 V | 331 | M | S54 # B | |
| Series code | | Rated voltage symbol | Rated capacitance symbol | Capacitance tolerance symbol | Casing symbol | Optional symbol |
| series LTH, three terminals type :400V330μF | | | | | | |
| LTH | — | 400 V | 331 | M | S54 # B | |
| Series code | | Rated voltage symbol | Rated capacitance symbol | Capacitance tolerance symbol | Casing symbol | Optional symbol |

Coefficient of Frequency for Rated Ripple Current

| Rated voltage (V) | Frequency (Hz) | | | | |
|-------------------|----------------|-----|------|------|------|
| | 50 | 120 | 1k | 10k | 30k |
| 100 or less | 0.95 | 1 | 1.10 | 1.15 | 1.15 |
| 160 to 250 | 0.87 | 1 | 1.11 | 1.18 | 1.20 |
| 315 or more | 0.80 | 1 | 1.14 | 1.19 | 1.20 |

Standard Ratings

| Rated voltage(V) Case φD×L(mm) Casing symbol Item | | 16 | | 25 | | 35 | | 50 | | 63 | | 80 | | 100 | |
|--|-----|------------------------|-----------------------------|------------------------|-----------------------------|------------------------|-----------------------------|------------------------|-----------------------------|------------------------|-----------------------------|------------------------|-----------------------------|------------------------|-----------------------------|
| | | Rated capacitance (μF) | Rated ripple current (Arms) | Rated capacitance (μF) | Rated ripple current (Arms) | Rated capacitance (μF) | Rated ripple current (Arms) | Rated capacitance (μF) | Rated ripple current (Arms) | Rated capacitance (μF) | Rated ripple current (Arms) | Rated capacitance (μF) | Rated ripple current (Arms) | Rated capacitance (μF) | Rated ripple current (Arms) |
| 22×25 | S22 | 6800 | 1.60 | 4700 | 1.55 | 3300 | 1.43 | 1800 | 1.31 | 1200 | 1.25 | 820 | 1.11 | 560 | 1.07 |
| 22×30 | S23 | 10000 | 1.99 | 6800 | 1.91 | 3900 | 1.65 | 2700 | 1.70 | 1800 | 1.52 | 1200 | 1.39 | 820 | 1.35 |
| 22×35 | S24 | 12000 | 2.28 | 8200 | 2.14 | 5600 | 2.02 | 3300 | 1.98 | 2200 | 1.73 | 1500 | 1.61 | 1000 | 1.54 |
| 22×40 | S25 | 15000 | 2.64 | 10000 | 2.40 | 6800 | 2.28 | 3900 | 2.25 | 2700 | 1.97 | 1800 | 1.83 | 1200 | 1.74 |
| 22×45 | S26 | 18000 | 2.98 | 12000 | 2.69 | — | — | 4700 | 2.56 | — | — | 2200 | 2.09 | 1500 | 1.99 |
| 22×50 | S27 | — | — | — | — | 8200 | 2.67 | 5600 | 2.89 | 3300 | 2.32 | — | — | — | — |
| 25×25 | S32 | 10000 | 1.99 | 6800 | 1.91 | 4700 | 1.78 | 2700 | 1.70 | 1800 | 1.52 | 1200 | 1.39 | 820 | 1.35 |
| 25×30 | S33 | 12000 | 2.30 | 8200 | 2.16 | 5600 | 2.04 | 3300 | 2.00 | 2200 | 1.75 | 1500 | 1.62 | 1000 | 1.56 |
| 25×35 | S34 | 15000 | 2.68 | 10000 | 2.44 | 6800 | 2.31 | 3900 | 2.28 | 2700 | 1.99 | 2200 | 2.01 | 1200 | 1.76 |
| 25×40 | S35 | 18000 | 3.04 | 12000 | 2.74 | 8200 | 2.60 | 5600 | 2.81 | 3300 | 2.27 | — | — | 1500 | 2.03 |
| 25×45 | S36 | 22000 | 3.40 | 15000 | 3.15 | 10000 | 2.92 | — | — | 3900 | 2.54 | 2700 | 2.43 | 1800 | 2.28 |
| 25×50 | S37 | 27000 | 3.81 | 18000 | 3.54 | 12000 | 3.26 | 6800 | 3.37 | 4700 | 2.88 | 3300 | 2.76 | 2200 | 2.57 |
| 30×25 | S42 | 12000 | 2.38 | 8200 | 2.25 | 5600 | 2.12 | 3900 | 2.22 | 2700 | 1.93 | 1800 | 1.81 | 1200 | 1.71 |
| 30×30 | S43 | 18000 | 3.00 | 12000 | 2.70 | 8200 | 2.56 | 4700 | 2.58 | 3300 | 2.24 | 2200 | 2.10 | 1500 | 2.00 |
| 30×35 | S44 | 22000 | 3.39 | 15000 | 3.13 | 10000 | 2.92 | 5600 | 2.95 | 3900 | 2.55 | 2700 | 2.43 | 1800 | 2.27 |
| 30×40 | S45 | 27000 | 3.83 | 18000 | 3.54 | 12000 | 3.28 | 6800 | 3.39 | 4700 | 2.90 | 3300 | 2.78 | 2200 | 2.59 |
| 30×45 | S46 | 33000 | 4.30 | 22000 | 4.24 | 15000 | 3.74 | 8200 | 3.71 | 5600 | 3.28 | 3900 | 3.12 | 2700 | 2.94 |
| 30×50 | S47 | 39000 | 4.74 | — | — | — | — | 10000 | 4.09 | 6800 | 3.73 | 4700 | 3.56 | 3300 | 3.32 |
| 35×25 | S52 | 18000 | 3.10 | 12000 | 2.80 | 8200 | 2.78 | 4700 | 2.67 | 3300 | 2.41 | 2200 | 2.17 | 1500 | 2.07 |
| 35×30 | S53 | 27000 | 3.74 | 15000 | 3.22 | 12000 | 3.20 | 6800 | 3.31 | 4700 | 2.83 | 3300 | 2.71 | 2200 | 2.52 |
| 35×35 | S54 | 33000 | 4.24 | 22000 | 3.96 | 15000 | 3.69 | 8200 | 3.66 | 5600 | 3.24 | 3900 | 3.07 | 2700 | 2.90 |
| 35×40 | S55 | 39000 | 4.72 | — | — | 18000 | 4.16 | 10000 | 4.07 | 6800 | 3.71 | 4700 | 3.50 | 3300 | 3.31 |
| 35×45 | S56 | 47000 | 5.27 | 27000 | 4.75 | — | — | 12000 | 4.50 | 8200 | 4.16 | 5600 | 3.87 | 3900 | 3.69 |
| 35×50 | S57 | — | — | 33000 | 5.39 | 22000 | 4.92 | — | — | 10000 | 4.69 | 6800 | 4.19 | 4700 | 4.14 |

| Rated voltage(V) Case φD×L(mm) Casing symbol Item | | 160 | | 180 | | 200 | | 250 | | 400 | | 450 | |
|--|-----|------------------------|-----------------------------|------------------------|-----------------------------|------------------------|-----------------------------|------------------------|-----------------------------|------------------------|-----------------------------|------------------------|-----------------------------|
| | | Rated capacitance (μF) | Rated ripple current (Arms) | Rated capacitance (μF) | Rated ripple current (Arms) | Rated capacitance (μF) | Rated ripple current (Arms) | Rated capacitance (μF) | Rated ripple current (Arms) | Rated capacitance (μF) | Rated ripple current (Arms) | Rated capacitance (μF) | Rated ripple current (Arms) |
| 22×25 | S22 | 330 | 1.16 | 270 | 1.08 | 220 | 1.08 | 180 | 0.94 | 68 | 0.47 | 56 | 0.47 |
| 22×30 | S23 | 390 | 1.43 | 330 | 1.30 | 330 | 1.30 | 220 | 1.10 | 82 | 0.56 | 68 | 0.56 |
| 22×35 | S24 | 470 | 1.52 | 470 | 1.50 | 390 | 1.41 | 270 | 1.13 | 120 | 0.64 | 82 | 0.64 |
| 22×40 | S25 | 560 | 1.62 | 560 | 1.62 | 470 | 1.50 | 330 | 1.20 | 150 | 0.70 | 100 | 0.70 |
| 22×45 | S26 | 680 | 1.70 | — | — | 560 | 1.58 | 390 | 1.26 | — | — | 120 | 0.73 |
| 22×50 | S27 | 820 | 1.81 | 680 | 1.76 | 680 | 1.68 | 470 | 1.37 | 180 | 0.78 | 150 | 0.78 |
| 25×25 | S32 | 470 | 1.55 | 390 | 1.35 | 330 | 1.35 | 220 | 1.15 | 82 | 0.65 | 68 | 0.65 |
| 25×30 | S33 | 560 | 1.73 | 470 | 1.62 | 470 | 1.47 | 330 | 1.30 | 120 | 0.70 | 100 | 0.70 |
| 25×35 | S34 | 680 | 1.81 | 560 | 1.69 | 560 | 1.65 | 390 | 1.41 | 150 | 0.73 | 120 | 0.73 |
| 25×40 | S35 | 820 | 1.98 | 680 | 1.72 | 680 | 1.80 | 470 | 1.52 | 180 | 0.82 | 150 | 0.82 |
| 25×45 | S36 | 1000 | 2.04 | 820 | 1.78 | — | — | 560 | 1.59 | 220 | 0.87 | 180 | 0.87 |
| 25×50 | S37 | 1200 | 2.12 | 1000 | 1.91 | 820 | 1.87 | 680 | 1.66 | 270 | 0.94 | 220 | 0.94 |
| 30×25 | S42 | 680 | 1.82 | 560 | 1.67 | 470 | 1.56 | 330 | 1.30 | 120 | 0.78 | 100 | 0.78 |
| 30×30 | S43 | 820 | 1.98 | 680 | 1.74 | 680 | 1.82 | 470 | 1.36 | 180 | 0.83 | 150 | 0.83 |
| 30×35 | S44 | 1000 | 2.14 | 820 | 1.85 | 820 | 1.99 | 560 | 1.57 | 220 | 0.86 | 180 | 0.86 |
| 30×40 | S45 | 1200 | 2.22 | 1000 | 2.01 | — | — | 680 | 1.76 | 270 | 0.95 | 220 | 0.95 |
| 30×45 | S46 | 1500 | 2.46 | 1200 | 2.19 | 1000 | 2.17 | 820 | 1.83 | 330 | 1.11 | 270 | 1.11 |
| 30×50 | S47 | — | — | 1500 | 2.36 | 1200 | 2.22 | 1000 | 1.87 | 390 | 1.15 | 330 | 1.15 |
| 35×25 | S52 | 820 | 1.93 | 680 | 1.92 | 680 | 1.96 | 470 | 1.40 | 180 | 0.86 | 150 | 0.86 |
| 35×30 | S53 | 1200 | 2.40 | 1000 | 2.16 | 820 | 2.07 | 560 | 1.56 | 270 | 0.91 | 220 | 0.91 |
| 35×35 | S54 | 1500 | 2.53 | 1200 | 2.34 | 1000 | 2.22 | 820 | 1.82 | 330 | 1.13 | 270 | 1.13 |
| 35×40 | S55 | — | — | 1500 | 2.56 | 1200 | 2.42 | 1000 | 1.99 | 390 | 1.26 | 330 | 1.26 |
| 35×45 | S56 | 1800 | 2.98 | 1800 | 2.67 | 1500 | 2.59 | 1200 | 2.10 | 470 | 1.31 | 390 | 1.31 |
| 35×50 | S57 | 2200 | 3.10 | — | — | 1800 | 2.70 | — | — | 560 | 1.50 | 470 | 1.50 |

(Note) Rated ripple current : 105°C , 120Hz

High-Reliability, High-Ripple, Long Life Capacitors

GREEN CAP 105°C 3000hours

- High-reliability, high-ripple, long life capacitors.
- Guarantees 3000 hours at 105°C.

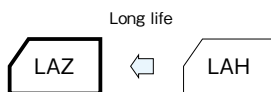

Marking color : White print on a black sleeve

Specifications

| Item | Performance | | | | | | | |
|---|--|---|------|------|------|-----------|------------|------------|
| Category temperature range (°C) | -40 to +105 (-25 to +105 at 160V or more) | | | | | | | |
| Tolerance at rated capacitance (%) | ±20 (20°C, 120Hz) | | | | | | | |
| Leakage current (µA) | Less than 0.02CV or 3mA whichever is smaller (after 5 minutes) C : Rated capacitance (µF) ; V : Rated voltage (V) (20°C) | | | | | | | |
| Tangent of loss angle (tanδ) | Rated voltage (V) | 16 | 25 | 35 | 50 | 63 to 100 | 160 to 250 | 400 to 450 |
| | tanδ (max.) | 0.50 | 0.40 | 0.35 | 0.30 | 0.20 | 0.15 | 0.20 |
| Characteristics at high and low temperature | Impedance ratio (max.) | Z-25°C/Z+20°C | 4 | 4 | 4 | | | |
| | | Z-40°C/Z+20°C | 15 | — | — | | | |
| Endurance (105°C) (Applied ripple current) | Test time | 3000 hours | | | | | | |
| | Leakage current | The initial specified value or less | | | | | | |
| | Percentage of capacitance change | Within ±20% of initial value | | | | | | |
| | Tangent of the loss angle | 200% or less of the initial specified value | | | | | | |
| Shelf life (105°C) | Test time | 1000 hours | | | | | | |
| | Leakage current | The initial specified value or less | | | | | | |
| | Percentage of capacitance change | Within ±15% of initial value | | | | | | |
| | Tangent of the loss angle | 150% or less of the initial specified value | | | | | | |
| Applicable standards | JIS C5101-1, -4 1998 (IEC 60384-1 1992, -4 1985) | | | | | | | |

Outline Drawing

Unit: mm

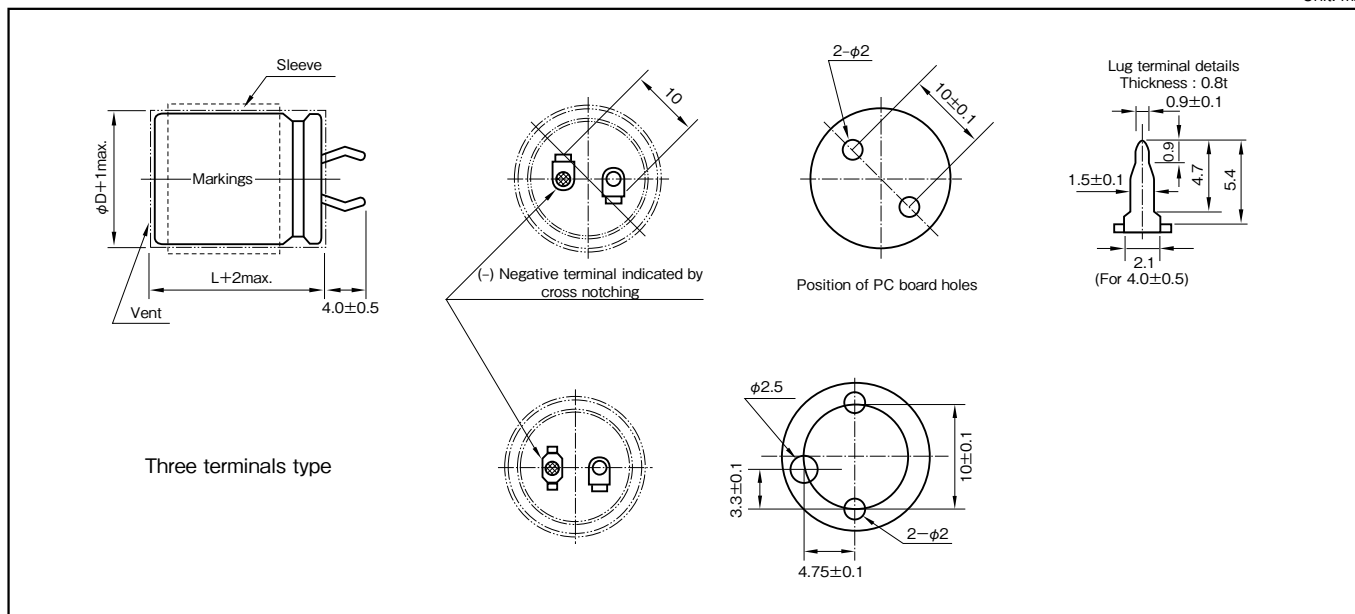

| Part numbering system | | | | | | |
|---|---|----------------------|--------------------------|------------------------------|---------------|-----------------|
| series LAZ, standard terminal type :400V330µF | | | | | | |
| LAZ | — | 400 V | 331 | M | S54 # B | |
| Series code | | Rated voltage symbol | Rated capacitance symbol | Capacitance tolerance symbol | Casing symbol | Optional symbol |
| series LTZ, three terminals type :400V330µF | | | | | | |
| LTZ | — | 400 V | 331 | M | S54 # B | |
| Series code | | Rated voltage symbol | Rated capacitance symbol | Capacitance tolerance symbol | Casing symbol | Optional symbol |

Coefficient of Frequency for Rated Ripple Current

| Rated voltage (V) | Frequency (Hz) | | | | |
|-------------------|----------------|-----|------|------|------|
| | 50 | 120 | 1k | 10k | 30k |
| 100 or less | 0.95 | 1 | 1.10 | 1.15 | 1.15 |
| 160 to 250 | 0.87 | 1 | 1.11 | 1.18 | 1.20 |
| 315 or more | 0.80 | 1 | 1.14 | 1.19 | 1.20 |

• The electric characteristics are described on page 185.

Standard Ratings

| Rated voltage(V) | | 16 | | 25 | | 35 | | 50 | | 63 | | 80 | | 100 | |
|------------------|-----|------------------------|-----------------------------|------------------------|-----------------------------|------------------------|-----------------------------|------------------------|-----------------------------|------------------------|-----------------------------|------------------------|-----------------------------|------------------------|-----------------------------|
| | | Rated capacitance (μF) | Rated ripple current (Arms) | Rated capacitance (μF) | Rated ripple current (Arms) | Rated capacitance (μF) | Rated ripple current (Arms) | Rated capacitance (μF) | Rated ripple current (Arms) | Rated capacitance (μF) | Rated ripple current (Arms) | Rated capacitance (μF) | Rated ripple current (Arms) | Rated capacitance (μF) | Rated ripple current (Arms) |
| 22x25 | S22 | 6800 | 1.60 | 4700 | 1.55 | 3300 | 1.43 | 1800 | 1.31 | 1200 | 1.25 | 820 | 1.11 | 560 | 1.07 |
| 22x30 | S23 | 10000 | 1.99 | 6800 | 1.91 | 3900 | 1.65 | 2700 | 1.70 | 1800 | 1.52 | 1200 | 1.39 | 820 | 1.35 |
| 22x35 | S24 | 12000 | 2.28 | 8200 | 2.14 | 5600 | 2.02 | 3300 | 1.98 | 2200 | 1.73 | 1500 | 1.61 | 1000 | 1.54 |
| 22x40 | S25 | 15000 | 2.64 | 10000 | 2.40 | 6800 | 2.28 | 3900 | 2.25 | 2700 | 1.97 | 1800 | 1.83 | 1200 | 1.74 |
| 22x45 | S26 | 18000 | 2.98 | 12000 | 2.69 | — | — | 4700 | 2.56 | — | — | 2200 | 2.09 | 1500 | 1.99 |
| 22x50 | S27 | — | — | — | — | 8200 | 2.67 | 5600 | 2.89 | 3300 | 2.32 | — | — | — | — |
| 25x25 | S32 | 10000 | 1.99 | 6800 | 1.91 | 4700 | 1.78 | 2700 | 1.70 | 1800 | 1.52 | 1200 | 1.39 | 820 | 1.35 |
| 25x30 | S33 | 12000 | 2.30 | 8200 | 2.16 | 5600 | 2.04 | 3300 | 2.00 | 2200 | 1.75 | 1500 | 1.62 | 1000 | 1.56 |
| 25x35 | S34 | 15000 | 2.68 | 10000 | 2.44 | 6800 | 2.31 | 3900 | 2.28 | 2700 | 1.99 | 2200 | 2.01 | 1200 | 1.76 |
| 25x40 | S35 | 18000 | 3.04 | 12000 | 2.74 | 8200 | 2.60 | 5600 | 2.81 | 3300 | 2.27 | — | — | 1500 | 2.03 |
| 25x45 | S36 | 22000 | 3.40 | 15000 | 3.15 | 10000 | 2.92 | — | — | 3900 | 2.54 | 2700 | 2.43 | 1800 | 2.28 |
| 25x50 | S37 | 27000 | 3.81 | 18000 | 3.54 | 12000 | 3.26 | 6800 | 3.37 | 4700 | 2.88 | 3300 | 2.76 | 2200 | 2.57 |
| 30x25 | S42 | 12000 | 2.38 | 8200 | 2.25 | 5600 | 2.12 | 3900 | 2.22 | 2700 | 1.93 | 1800 | 1.81 | 1200 | 1.71 |
| 30x30 | S43 | 18000 | 3.00 | 12000 | 2.70 | 8200 | 2.56 | 4700 | 2.58 | 3300 | 2.24 | 2200 | 2.10 | 1500 | 2.00 |
| 30x35 | S44 | 22000 | 3.39 | 15000 | 3.13 | 10000 | 2.92 | 5600 | 2.95 | 3900 | 2.55 | 2700 | 2.43 | 1800 | 2.27 |
| 30x40 | S45 | 27000 | 3.83 | 18000 | 3.54 | 12000 | 3.28 | 6800 | 3.39 | 4700 | 2.90 | 3300 | 2.78 | 2200 | 2.59 |
| 30x45 | S46 | 33000 | 4.30 | 22000 | 4.24 | 15000 | 3.74 | 8200 | 3.71 | 5600 | 3.28 | 3900 | 3.12 | 2700 | 2.94 |
| 30x50 | S47 | 39000 | 4.74 | — | — | — | — | 10000 | 4.09 | 6800 | 3.73 | 4700 | 3.56 | 3300 | 3.32 |
| 35x25 | S52 | 18000 | 3.10 | 12000 | 2.80 | 8200 | 2.78 | 4700 | 2.67 | 3300 | 2.41 | 2200 | 2.17 | 1500 | 2.07 |
| 35x30 | S53 | 27000 | 3.74 | 15000 | 3.22 | 12000 | 3.20 | 6800 | 3.31 | 4700 | 2.83 | 3300 | 2.71 | 2200 | 2.52 |
| 35x35 | S54 | 33000 | 4.24 | 22000 | 3.96 | 15000 | 3.69 | 8200 | 3.66 | 5600 | 3.24 | 3900 | 3.07 | 2700 | 2.90 |
| 35x40 | S55 | 39000 | 4.72 | — | — | 18000 | 4.16 | 10000 | 4.07 | 6800 | 3.71 | 4700 | 3.50 | 3300 | 3.31 |
| 35x45 | S56 | 47000 | 5.27 | 27000 | 4.75 | — | — | 12000 | 4.50 | 8200 | 4.16 | 5600 | 3.87 | 3900 | 3.69 |
| 35x50 | S57 | — | — | 33000 | 5.39 | 22000 | 4.92 | — | — | 10000 | 4.69 | 6800 | 4.19 | 4700 | 4.14 |

| Rated voltage(V) | | 160 | | 180 | | 200 | | 250 | | 400 | | 450 | |
|------------------|-----|------------------------|-----------------------------|------------------------|-----------------------------|------------------------|-----------------------------|------------------------|-----------------------------|------------------------|-----------------------------|------------------------|-----------------------------|
| | | Rated capacitance (μF) | Rated ripple current (Arms) | Rated capacitance (μF) | Rated ripple current (Arms) | Rated capacitance (μF) | Rated ripple current (Arms) | Rated capacitance (μF) | Rated ripple current (Arms) | Rated capacitance (μF) | Rated ripple current (Arms) | Rated capacitance (μF) | Rated ripple current (Arms) |
| 22x20 | S21 | 180 | 0.70 | 180 | 0.70 | 150 | 0.76 | 120 | 0.63 | 47 | 0.37 | — | — |
| 22x25 | S22 | 330 | 1.42 | 270 | 1.08 | 270 | 1.17 | 180 | 1.00 | 68 | 0.48 | 56 | 0.50 |
| 22x30 | S23 | 390 | 1.43 | 330 | 1.30 | 330 | 1.40 | 220 | 1.20 | 82 | 0.57 | 68 | 0.60 |
| 22x35 | S24 | 470 | 1.63 | 390 | 1.35 | 390 | 1.45 | — | — | 100 | 0.62 | 82 | 0.63 |
| 22x40 | S25 | 560 | 1.75 | 470 | 1.50 | 470 | 1.55 | 270 | 1.25 | 120 | 0.75 | 82 | 0.65 |
| 22x45 | S26 | 680 | 1.98 | 560 | 1.62 | 470 | 1.63 | 330 | 1.30 | 150 | 0.85 | 100 | 0.76 |
| 22x50 | S27 | 820 | 2.35 | 680 | 1.75 | 560 | 1.65 | 390 | 1.49 | 180 | 0.98 | 120 | 0.80 |
| 25x20 | S31 | 220 | 0.95 | 220 | 0.85 | 220 | 0.94 | 150 | 0.92 | 68 | 0.46 | — | — |
| 25x25 | S32 | 270 | 1.02 | — | — | — | — | — | — | — | — | — | — |
| 25x30 | S33 | 390 | 1.45 | 390 | 1.35 | 330 | 1.40 | 220 | 1.20 | 82 | 0.65 | 68 | 0.56 |
| 25x35 | S34 | 470 | 1.55 | — | — | — | — | — | — | 100 | 0.65 | 82 | 0.64 |
| 25x40 | S35 | 560 | 1.73 | 470 | 1.62 | 470 | 1.55 | 330 | 1.35 | 120 | 0.71 | 100 | 0.72 |
| 25x45 | S36 | 680 | 1.82 | — | — | — | — | — | — | 150 | 0.83 | 120 | 0.79 |
| 25x50 | S37 | 820 | 2.35 | 560 | 1.69 | 560 | 1.65 | 390 | 1.45 | 150 | 0.85 | 120 | 0.80 |
| 30x20 | S41 | 820 | 1.98 | 680 | 1.72 | — | — | — | — | 180 | 0.98 | 150 | 0.88 |
| 30x25 | S42 | 820 | 2.35 | 680 | 1.75 | 680 | 1.92 | 470 | 1.67 | 180 | 1.01 | 150 | 0.95 |
| 30x30 | S43 | 1000 | 2.50 | 820 | 1.85 | — | — | — | — | 220 | 1.05 | 180 | 1.04 |
| 30x35 | S44 | 1200 | 2.74 | 820 | 1.85 | 820 | 2.20 | 560 | 1.85 | 220 | 1.20 | 180 | 1.05 |
| 30x40 | S45 | 1500 | 3.21 | 1000 | 1.91 | — | — | — | — | 270 | 1.33 | 220 | 1.16 |
| 30x45 | S46 | 1800 | 3.57 | 1200 | 1.95 | 820 | 2.29 | 680 | 2.20 | 270 | 1.35 | 220 | 1.30 |
| 30x50 | S47 | 2200 | 4.27 | 1500 | 2.36 | 1200 | 2.29 | 820 | 2.20 | 330 | 1.49 | — | — |
| 35x20 | S51 | 1800 | 4.07 | 1500 | 2.52 | 1200 | 2.86 | 1000 | 2.90 | 390 | 1.80 | 330 | 1.90 |
| 35x25 | S52 | — | — | — | — | 1500 | 3.20 | — | — | 470 | 1.98 | — | — |
| 35x30 | S53 | 560 | 1.82 | 470 | 1.40 | 470 | 1.67 | 330 | 1.30 | 150 | 0.86 | — | — |
| 35x35 | S54 | 820 | 2.35 | 680 | 1.92 | 680 | 2.20 | 470 | 1.65 | 180 | 1.00 | 150 | 0.95 |
| 35x40 | S55 | — | — | 820 | 1.95 | — | — | 560 | 1.80 | 220 | 1.11 | 220 | 1.15 |
| 35x45 | S56 | 1000 | 2.50 | 1000 | 2.16 | 820 | 2.40 | 560 | 1.85 | 270 | 1.35 | 220 | 1.35 |
| 35x50 | S57 | 1200 | 2.74 | — | — | 1000 | 2.50 | 680 | 2.04 | 330 | 1.49 | — | — |
| 40x20 | S61 | 1500 | 3.21 | 1200 | 2.34 | 1200 | 2.63 | 820 | 2.35 | 330 | 1.60 | 270 | 1.28 |
| 40x25 | S62 | — | — | 1500 | 2.56 | — | — | — | — | 390 | 1.74 | 330 | 1.57 |
| 40x30 | S63 | 1800 | 3.94 | 1500 | 2.56 | 1200 | 2.75 | 1000 | 2.90 | 390 | 1.80 | 390 | 2.00 |
| 40x35 | S64 | — | — | 1800 | 2.60 | 1500 | 3.45 | — | — | 470 | 1.98 | — | — |
| 40x40 | S65 | 1800 | 4.15 | 1800 | 2.67 | 1500 | 3.60 | 1200 | 3.30 | 470 | 2.10 | 470 | 2.27 |
| 40x45 | S66 | 2200 | 4.35 | — | — | 1800 | 4.00 | — | — | 560 | 2.30 | — | — |
| 40x50 | S67 | 2700 | 4.65 | 2200 | 3.15 | 1800 | 4.16 | 1500 | 3.80 | 560 | 2.48 | — | — |
| 45x20 | S71 | 2700 | 5.15 | — | — | 2200 | 4.50 | — | — | — | — | — | — |

(Note) Rated ripple current : 105°C , 120Hz

NOTE : Design, Specifications are subject to change without notice.
It is recommended that you shall obtain technical specifications from ELNA to ensure that the component is suitable for your use.

Ultra Long Life, High-Reliability Capacitors

GREEN CAP **105°C**
5000hours

- Ultra Long Life, high-reliability capacitors.
- Guarantees 5000 hours at 105°C.

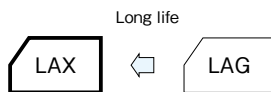

Marking color : White print on a black sleeve

Specifications

| Item | Performance | | | | | |
|---|--|---|----------------------------------|------|------|------|
| Category temperature range (°C) | -25 to +105 | | | | | |
| Tolerance at rated capacitance (%) | ±20 (20°C, 120Hz) | | | | | |
| Leakage current (µA) | Less than 0.02CV or 3mA whichever is smaller (after 5 minutes) C : Rated capacitance (µF) ; V : Rated voltage (V) (20°C) | | | | | |
| Tangent of loss angle (tanδ) | Rated voltage (V) | 160 | 200 | 250 | 400 | 450 |
| | tanδ (max.) | 0.215 | 0.15 | 0.15 | 0.20 | 0.20 |
| Characteristics at high and low temperature | Percentage of capacitance change (%) | -25°C | Within ±30% of the value at 20°C | | | |
| | Impedance ratio (max.) | Z-25°C/Z+20°C | 4 (120Hz) | | | |
| Endurance (105°C) (Applied ripple current) | Test time | 5000 hours | | | | |
| | Leakage current | The initial specified value or less | | | | |
| | Percentage of capacitance change | Within ±20% of initial value | | | | |
| | Tangent of the loss angle | 200% or less of the initial specified value | | | | |
| Shelf life (105°C) | Test time | 1000 hours | | | | |
| | Leakage current | The initial specified value or less | | | | |
| | Percentage of capacitance change | Within ±15% of initial value | | | | |
| | Tangent of the loss angle | 150% or less of the initial specified value | | | | |
| Voltage application treatment | | | | | | |
| Applicable standards | JIS C5101-1, -4 1998 (IEC 60384-1 1992, -4 1985) | | | | | |

Outline Drawing

Unit: mm

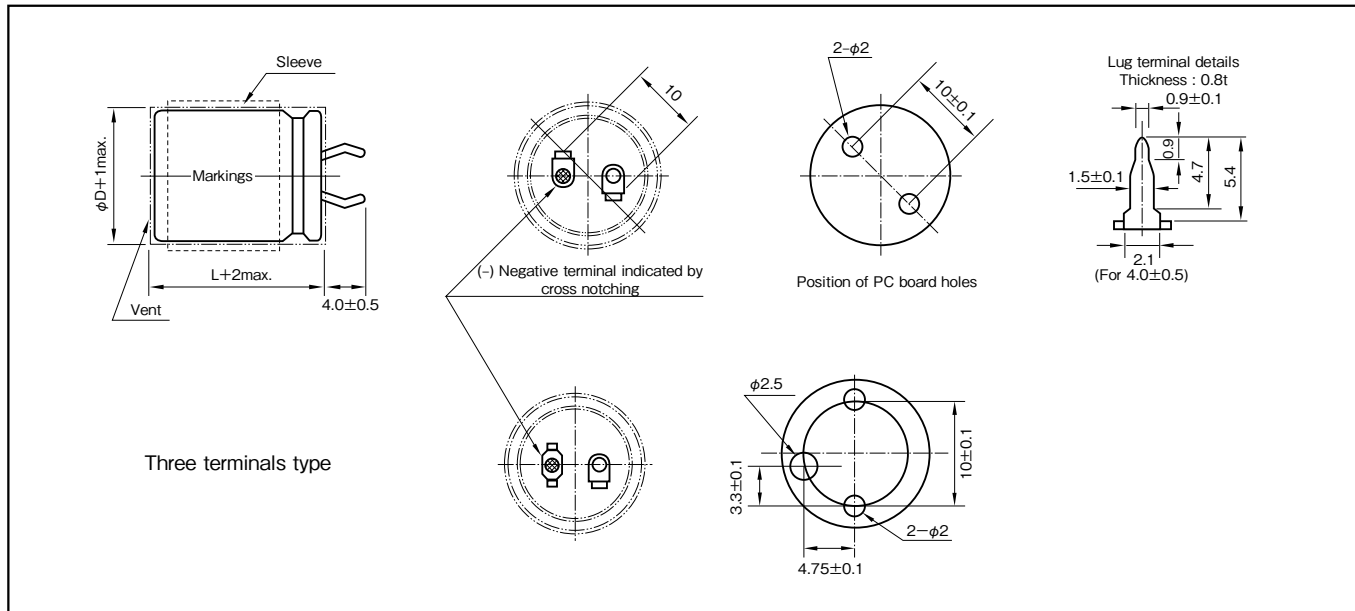

| Part numbering system | | | | | |
|--|----------------------|--------------------------|------------------------------|---------------|-----------------|
| series LAX, standard terminal type : 400V470µF | | | | | |
| LAX | — 200 V | 471 | M | S34 # | B |
| Series code | Rated voltage symbol | Rated capacitance symbol | Capacitance tolerance symbol | Casing symbol | Optional symbol |
| series LTX, three terminals type : 400V220µF | | | | | |
| LTX | — 400 V | 221 | M | S53 # | B |
| Series code | Rated voltage symbol | Rated capacitance symbol | Capacitance tolerance symbol | Casing symbol | Optional symbol |

Coefficient of Frequency for Rated Ripple Current

| Rated voltage (V) | Frequency (Hz) | | | | |
|-------------------|----------------|-----|------|------|------|
| | 50 | 120 | 1k | 10k | 30k |
| 160 to 250 | 0.87 | 1 | 1.11 | 1.18 | 1.20 |
| 400, 450 | 0.80 | 1 | 1.14 | 1.19 | 1.20 |

• The electric characteristics are described on page 186.

Standard Ratings

| Case φD×L(mm) | Item Casing symbol | 160 | | 200 | | 250 | | 400 | | 450 | |
|------------------|--------------------------|------------------------------|-----------------------------------|------------------------------|-----------------------------------|------------------------------|-----------------------------------|------------------------------|-----------------------------------|------------------------------|-----------------------------------|
| | | Rated capacitance (μF) | Rated ripple current (Arms) | Rated capacitance (μF) | Rated ripple current (Arms) | Rated capacitance (μF) | Rated ripple current (Arms) | Rated capacitance (μF) | Rated ripple current (Arms) | Rated capacitance (μF) | Rated ripple current (Arms) |
| 22×25 | S22 | 270 | 0.91 | 180 | 0.75 | 150 | 0.68 | 56 | 0.34 | — | — |
| 22×30 | S23 | 330 | 1.09 | 270 | 0.99 | 180 | 0.81 | 68 | 0.40 | 68 | 0.38 |
| 22×35 | S24 | 390 | 1.27 | 330 | 1.16 | 220 | 0.95 | 82 | 0.47 | 82 | 0.44 |
| 22×40 | S25 | 470 | 1.36 | 390 | 1.24 | 270 | 1.03 | 120 | 0.56 | 100 | 0.50 |
| 22×45 | S26 | 560 | 1.44 | 470 | 1.31 | 330 | 1.10 | — | — | — | — |
| 22×50 | S27 | 680 | 1.52 | — | — | 390 | 1.16 | 150 | 0.63 | 120 | 0.58 |
| 25×25 | S32 | 390 | 1.15 | 270 | 0.96 | 180 | 0.78 | 82 | 0.41 | — | — |
| 25×30 | S33 | 470 | 1.36 | 330 | 1.14 | 270 | 1.03 | 100 | 0.51 | 82 | 0.45 |
| 25×35 | S34 | 560 | 1.54 | 470 | 1.45 | 330 | 1.21 | 120 | 0.60 | 100 | 0.52 |
| 25×40 | S35 | 680 | 1.68 | 560 | 1.55 | 390 | 1.29 | 150 | 0.66 | 120 | 0.58 |
| 25×45 | S36 | 820 | 1.74 | — | — | — | — | 180 | 0.72 | 150 | 0.66 |
| 25×50 | S37 | — | — | 680 | 1.72 | 470 | 1.43 | 220 | 0.80 | 180 | 0.74 |
| 30×25 | S42 | 560 | 1.45 | 390 | 1.21 | 270 | 1.01 | 100 | 0.50 | 82 | 0.46 |
| 30×30 | S43 | 680 | 1.68 | 470 | 1.43 | 330 | 1.16 | 150 | 0.66 | 120 | 0.58 |
| 30×35 | S44 | 820 | 1.82 | 560 | 1.66 | 470 | 1.33 | 180 | 0.77 | 150 | 0.68 |
| 30×40 | S45 | 1000 | 1.90 | 680 | 1.79 | 560 | 1.48 | 220 | 0.85 | 180 | 0.77 |
| 30×45 | S46 | — | — | 820 | 1.95 | 680 | 1.71 | — | — | 220 | 0.88 |
| 30×50 | S47 | 1200 | 2.09 | 1000 | 2.00 | 820 | 1.94 | 330 | 1.12 | 270 | 0.99 |
| 35×30 | S53 | 820 | 1.93 | 680 | 1.76 | 470 | 1.33 | 220 | 0.89 | 180 | 0.77 |
| 35×35 | S54 | 1000 | 2.15 | 820 | 2.05 | 560 | 1.55 | 270 | 0.96 | 220 | 0.88 |
| 35×40 | S55 | 1500 | 2.52 | 1000 | 2.22 | 680 | 1.69 | 330 | 1.12 | 270 | 1.01 |
| 35×45 | S56 | — | — | 1200 | 2.38 | 1000 | 2.20 | 390 | 1.27 | 330 | 1.15 |
| 35×50 | S57 | 1800 | 2.63 | 1500 | 2.76 | — | — | 470 | 1.33 | 390 | 1.28 |

(Note) Rated ripple current : 105°C , 120Hz

LJ6, LJ2 LARGE CAPACITANCE ALUMINUM ELECTROLYTIC CAPACITORS ELNA®

Large-Capacitance, Long-Life, High-Reliability Capacitors

GREEN CAP

105°C
5000hours

- Large-capacitance, Long-life, High-reliability capacitors.
- Guarantees 5000 hours at 105°C.

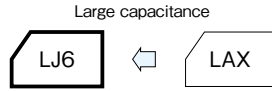

Marking color : White print on a black sleeve

Specifications

| Item | Performance | |
|---|--|---|
| Category temperature range (°C) | -25~+105 | |
| Tolerance at rated capacitance (%) | ±20 (20°C, 120Hz) | |
| Leakage current (µA) | Less than 0.02CV or 5mA whichever is smaller (after 5 minutes) C : Rated capacitance (µF) ; V : Rated voltage (V) (20°C) | |
| Tangent of loss angle (tanδ) | Rated voltage (V) | 200 to 500 |
| | tanδ (max.) | 0.15 (20°C, 120Hz) |
| Characteristics at high and low temperature | Percentage of capacitance change (%) | Within ±30% of the value at 20°C |
| | Impedance ratio (max.) | 4 (120Hz) |
| Endurance (105°C) (Applied ripple current) | Test time | 5000 hours |
| | Leakage current | The initial specified value or less |
| | Percentage of capacitance change | Within ±20% of initial value |
| | Tangent of the loss angle | 200% or less of the initial specified value |
| Shelf life (105°C) | Test time | 1000 hours |
| | Leakage current | The initial specified value or less |
| | Percentage of capacitance change | Within ±15% of initial value |
| | Tangent of the loss angle | 150% or less of the initial specified value |
| Voltage application treatment | | |
| Applicable standards | JIS C5101-1, -4 1998 (IEC 60384-1 1992, -4 1985) | |

Outline Drawing

Unit : mm

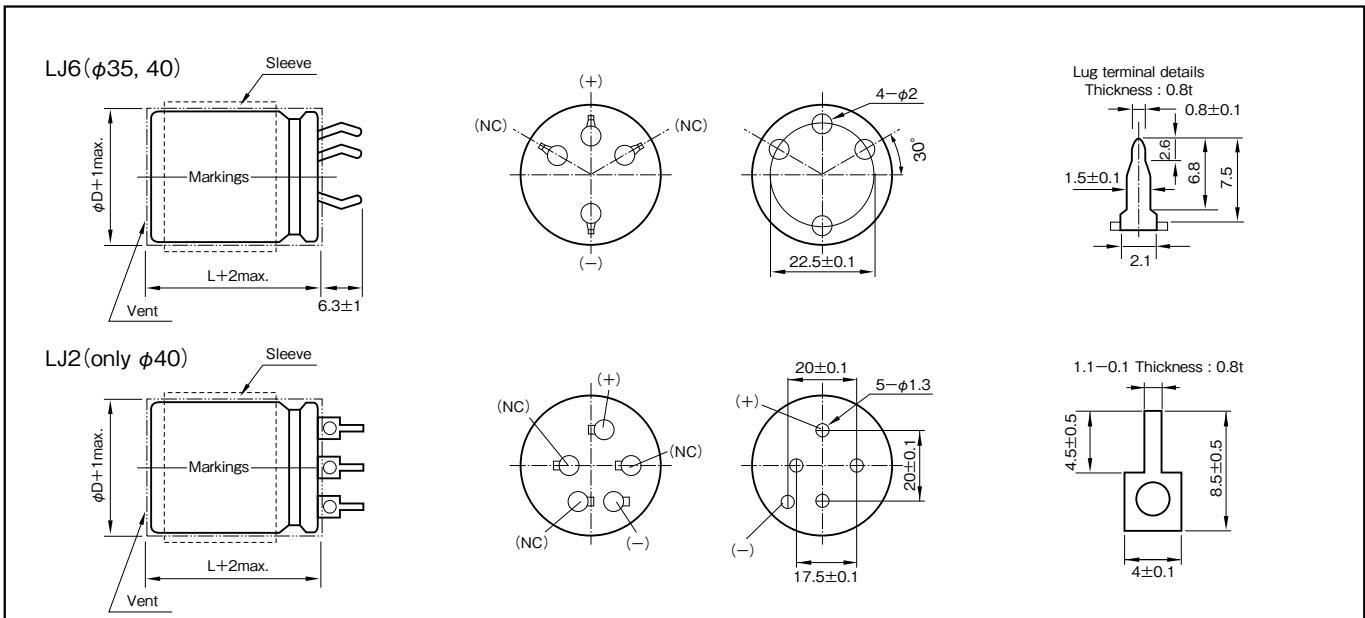

Part numbering system (example : 350V1500µF)

| | | | | | | | | |
|-------------|---|----------------------|---|--------------------------|------------------------------|---------------|---|-----------------|
| LJ6 | — | 350 | V | 152 | M | S6D | # | B |
| Series code | | Rated voltage symbol | | Rated capacitance symbol | Capacitance tolerance symbol | Casing symbol | | Optional symbol |

Coefficient of Frequency for Rated Ripple Current

| Rated voltage (V) | Frequency (Hz) | | | | |
|-------------------|----------------|-----|------|------|------|
| | 50 | 120 | 1k | 10k | 30k |
| 200 to 250 | 0.87 | 1 | 1.11 | 1.18 | 1.20 |
| 315 to 500 | 0.80 | 1 | 1.14 | 1.19 | 1.20 |

NOTE : Design, Specifications are subject to change without notice. It is recommended that you shall obtain technical specifications from ELNA to ensure that the component is suitable for your use.

Standard Ratings

| Case φD×L (mm) | | Item Casing symbol | 200 | | | 250 | | | 315 | | | 350 | | |
|-------------------|-----|--------------------------|---------------------------|-----------------|--------------------------------|---------------------------|-----------------|--------------------------------|---------------------------|-----------------|--------------------------------|---------------------------|-----------------|--------------------------------|
| | | | Rated capacitance (μF) | ESR (Ω Max.) | Rated ripple current (Arms) | Rated capacitance (μF) | ESR (Ω Max.) | Rated ripple current (Arms) | Rated capacitance (μF) | ESR (Ω Max.) | Rated ripple current (Arms) | Rated capacitance (μF) | ESR (Ω Max.) | Rated ripple current (Arms) |
| 35×60 | S59 | 2200 | 0.090 | 4.05 | 1500 | 0.13 | 3.17 | 820 | 0.24 | 2.23 | 820 | 0.24 | 2.10 | |
| 35×70 | S5B | 2700 | 0.073 | 4.77 | 1800 | 0.11 | 3.69 | 1000 | 0.20 | 2.62 | 1000 | 0.20 | 2.46 | |
| 35×80 | S5C | 3300 | 0.060 | 5.56 | 2200 | 0.090 | 4.31 | 1200 | 0.17 | 3.03 | 1200 | 0.17 | 2.84 | |
| 35×90 | S5D | — | — | — | — | — | — | 1500 | 0.13 | 3.55 | 1500 | 0.13 | 3.34 | |
| 35×100 | S5E | 3900 | 0.051 | 6.64 | 2700 | 0.073 | 5.24 | 1800 | 0.11 | 4.07 | 1800 | 0.11 | 3.82 | |
| 40×60 | S69 | 2200 | 0.090 | 4.40 | 1800 | 0.11 | 3.77 | 1000 | 0.20 | 2.68 | 1000 | 0.20 | 2.50 | |
| 40×70 | S6B | 2700 | 0.073 | 5.17 | 2200 | 0.090 | 4.43 | 1200 | 0.17 | 3.11 | 1200 | 0.17 | 2.90 | |
| 40×80 | S6C | 3300 | 0.060 | 6.02 | — | — | — | 1500 | 0.13 | 3.67 | 1500 | 0.13 | 3.40 | |
| 40×90 | S6D | 3900 | 0.051 | 7.00 | 2700 | 0.073 | 5.42 | 1800 | 0.11 | 4.21 | 1800 | 0.11 | 3.95 | |

| Case φD×L (mm) | | Item Casing symbol | 400 | | | 450 | | | 500 | | |
|-------------------|-----|--------------------------|---------------------------|-----------------|--------------------------------|---------------------------|-----------------|--------------------------------|---------------------------|-----------------|--------------------------------|
| | | | Rated capacitance (μF) | ESR (Ω Max.) | Rated ripple current (Arms) | Rated capacitance (μF) | ESR (Ω Max.) | Rated ripple current (Arms) | Rated capacitance (μF) | ESR (Ω Max.) | Rated ripple current (Arms) |
| 35×60 | S59 | 820 | 0.24 | 2.49 | 560 | 0.36 | 2.16 | 390 | 0.51 | 1.65 | |
| 35×70 | S5B | 1000 | 0.20 | 2.93 | 680 | 0.29 | 2.53 | 470 | 0.42 | 1.92 | |
| 35×80 | S5C | — | — | — | 820 | 0.24 | 2.94 | 560 | 0.36 | 2.22 | |
| 35×90 | S5D | 1200 | 0.17 | 3.55 | 1000 | 0.20 | 3.41 | 680 | 0.29 | 2.57 | |
| 35×100 | S5E | 1500 | 0.13 | 4.15 | 1200 | 0.17 | 3.90 | — | — | — | |
| 40×60 | S69 | — | — | — | 680 | 0.29 | 2.45 | 560 | 0.36 | 2.15 | |
| 40×70 | S6B | 1000 | 0.20 | 3.10 | 820 | 0.24 | 2.84 | 680 | 0.29 | 2.51 | |
| 40×80 | S6C | — | — | — | 1000 | 0.20 | 3.33 | — | — | — | |
| 40×90 | S6D | 1200 | 0.17 | 3.65 | 1200 | 0.17 | 3.65 | 820 | 0.24 | 3.05 | |
| 40×100 | S6E | 1500 | 0.13 | 4.30 | — | — | — | 1000 | 0.20 | 3.51 | |

(Note) Rated ripple current : 105°C , 120Hz ; ESR. : 20°C , 120Hz

LM, LPM LARGE CAPACITANCE ALUMINUM ELECTROLYTIC CAPACITORS ELNA®

For-Inverter, High-Ripple Capacitors

GREEN CAP 85°C 2000hours

- Withstands high-ripple current generated by the voltage doubler rectifier system.
- Guarantees 2000 hours at 85°C.



Marking color : White print on a black sleeve

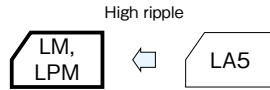

Specifications

| Item | Performance | |
|--|--|---|
| Category temperature range (°C) | -25 to +85 | |
| Tolerance at rated capacitance (%) | ±10 (20°C, 120Hz) | |
| Leakage current (µA) | Less than 0.01CV or 5mA whichever is smaller (after 5 minutes) C : Rated capacitance (µF) ; V : Rated voltage (V) (20°C) | |
| Tangent of loss angle (tanδ) | Rated voltage (V) | 250, 400 |
| | tanδ (max.) | 0.05 (20°C, 120Hz) |
| Characteristics at high and low temperature | Rated voltage (V) | 250, 400 |
| | Impedance ratio (max.) Z-25°C/Z+20°C | 4 (120Hz) |
| Endurance (85°C) (Applied ripple current) | Test time | 2000 hours |
| | Leakage current | The initial specified value or less |
| | Percentage of capacitance change | Within ±20% of initial value |
| | Tangent of the loss angle | 200% or less of the initial specified value |
| Shelf life (85°C) | Test time | 500 hours |
| | Leakage current | The initial specified value or less |
| | Percentage of capacitance change | Within ±15% of initial value |
| | Tangent of the loss angle | 150% or less of the initial specified value |
| Applicable standards | Voltage application treatment JIS C5101-1, -4 1998 (IEC 60384-1 1992, -4 1985) | |

Outline Drawing

Unit : mm

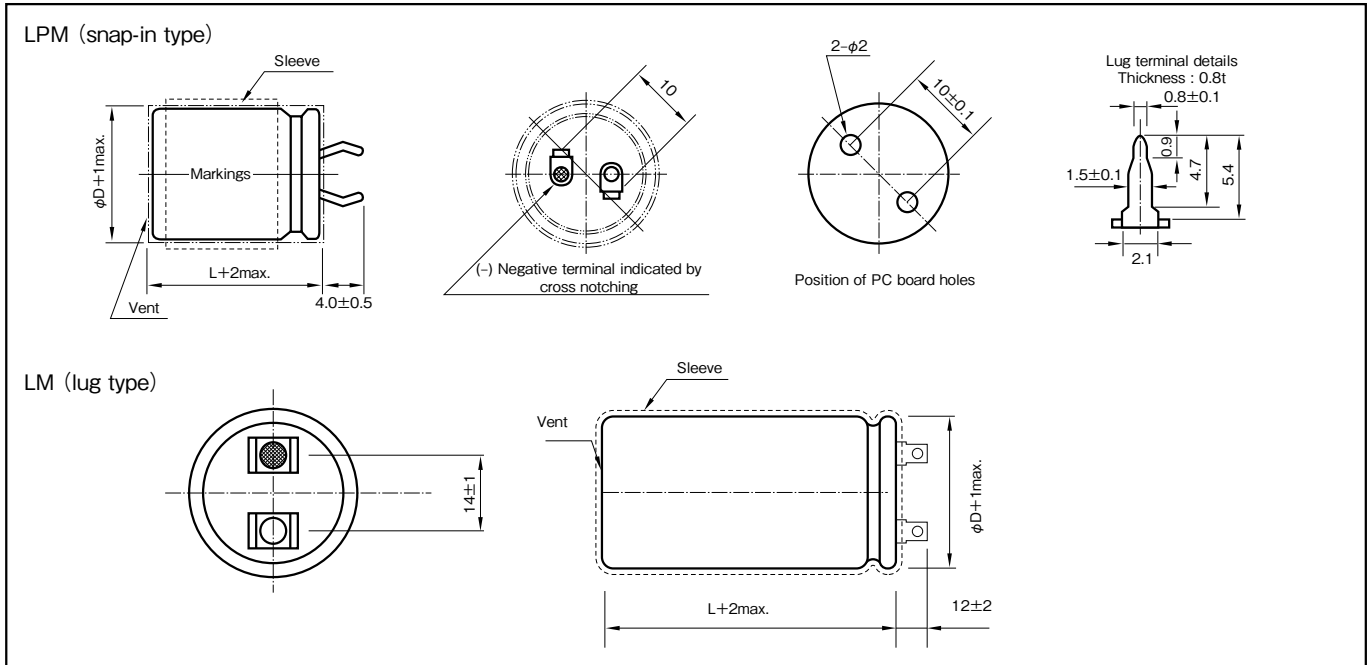

Part numbering system (example : 250V440µF)

| | | | | | | |
|-------------|----------------------|--------------------------|------------------------------|---------------|-----------------|---|
| LM | — | 250 V | 441 | K | S6E # | B |
| Series code | Rated voltage symbol | Rated capacitance symbol | Capacitance tolerance symbol | Casing symbol | Optional symbol | |

Coefficient of Frequency for Rated Ripple Current

| Rated voltage (V) | Frequency (Hz) | | | | |
|-------------------|----------------|-----|------|------|------|
| | 50 | 120 | 400 | 1k | 10k |
| 250, 400 | 0.80 | 1 | 1.32 | 1.46 | 1.61 |

LM series Standard Ratings

| 250V | | | | | |
|---------------------------------|-----------|-----|---------------|------------------|--------------------------------|
| Rated capacitance (μ F) | Case (mm) | | Casing symbol | ESR | Rated ripple current (Arms) |
| | ϕ D | L | | (Ω max.) | |
| 200 | 40 | 100 | S6E | 0.33 | 3.80 |
| 220 | 40 | 100 | S6E | 0.30 | 4.00 |
| 330 | 40 | 100 | S6E | 0.20 | 4.85 |
| 360 | 40 | 100 | S6E | 0.18 | 5.10 |
| 390 | 40 | 100 | S6E | 0.17 | 5.30 |
| 420 | 40 | 100 | S6E | 0.16 | 5.50 |
| 440 | 40 | 100 | S6E | 0.15 | 5.60 |

| 400V | | | | | |
|---------------------------------|-----------|-----|---------------|------------------|--------------------------------|
| Rated capacitance (μ F) | Case (mm) | | Casing symbol | ESR | Rated ripple current (Arms) |
| | ϕ D | L | | (Ω max.) | |
| 90 | 35 | 80 | S5C | 0.74 | 3.00 |
| | 40 | 80 | S6C | 0.74 | 3.00 |
| 100 | 35 | 90 | S5D | 0.66 | 3.20 |
| | 40 | 90 | S6D | 0.66 | 3.20 |
| 110 | 35 | 100 | S5E | 0.60 | 3.30 |
| | 40 | 100 | S6E | 0.60 | 3.30 |
| 150 | 35 | 100 | S5E | 0.44 | 3.90 |
| | 40 | 100 | S6E | 0.44 | 3.90 |
| 165 | 40 | 100 | S6E | 0.40 | 4.10 |
| 220 | 40 | 100 | S6E | 0.30 | 4.10 |

(Note) Rated ripple current : 85°C , 120Hz ; ESR. : 20°C , 120Hz

LPM series Standard Ratings

| 250V | | | | | |
|---------------------------------|-----------|----|---------------|------------------|--------------------------------|
| Rated capacitance (μ F) | Case (mm) | | Casing symbol | ESR | Rated ripple current (Arms) |
| | ϕ D | L | | (Ω max.) | |
| 100 | 35 | 40 | S55 | 0.66 | 1.90 |
| 110 | 35 | 40 | S55 | 0.60 | 2.00 |
| 165 | 35 | 45 | S56 | 0.40 | 2.45 |
| 180 | 35 | 50 | S57 | 0.37 | 2.58 |
| 195 | 35 | 50 | S57 | 0.34 | 2.68 |
| 210 | 35 | 50 | S57 | 0.32 | 2.78 |
| 220 | 35 | 50 | S57 | 0.30 | 2.80 |

| 400V | | | | | |
|---------------------------------|-----------|----|---------------|------------------|--------------------------------|
| Rated capacitance (μ F) | Case (mm) | | Casing symbol | ESR | Rated ripple current (Arms) |
| | ϕ D | L | | (Ω max.) | |
| 45 | 35 | 50 | S57 | 1.47 | 1.50 |
| 55 | 35 | 40 | S55 | 1.21 | 1.70 |
| 75 | 35 | 50 | S57 | 0.88 | 1.98 |
| 82 | 35 | 50 | S57 | 0.81 | 2.00 |

(Note) Rated ripple current : 85°C , 120Hz ; ESR. : 20°C , 120Hz

Screw Terminal, Long Life, High Temperature capacitors

GREEN CAP 105°C 2000hours

- Screw Terminal, Long Life, High Temperature capacitors.
- Guarantees 5000 hours at 105°C.



Marking color : Silver print on a black sleeve

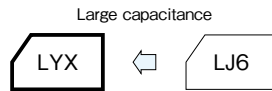

Specifications

| Item | Performance | |
|---|--|---|
| Category temperature range (°C) | -40 to +105 | |
| Tolerance at rated capacitance (%) | ±20 (20°C, 120Hz) | |
| Leakage current (µA) | Less than 0.01CV or 5mA whichever is smaller (after 5 minutes) C : Rated capacitance (µF) ; V : Rated voltage (V) (20°C) | |
| Tangent of loss angle (tanδ) | 0.20 (20°C, 120Hz) | |
| Endurance (105°C) (Applied ripple current) | Test time | 5000 hours |
| | Leakage current | The initial specified value or less |
| | Percentage of capacitance change | Within ±20% of initial value |
| | Tangent of the loss angle | 200% or less of the initial specified value |
| Shelf life (105°C) | Test time | 1000 hours |
| | Leakage current | The initial specified value or less |
| | Percentage of capacitance change | Within ±20% of initial value |
| | Tangent of the loss angle | 200% or less of the initial specified value |
| Voltage application treatment | | |
| Applicable standards | JIS C5101-1, -4 1998 (IEC 60384-1 1992, -4 1995) | |

Outline Drawing

Unit : mm

| φD | 36 | 51 | 64 | 77 | 90 | 101 |
|-----|------|------|------|------|------|------|
| F±1 | 12.7 | 22.0 | 28.2 | 31.4 | 31.4 | 41.5 |

Mounting Clamp

Unit : mm

Code J (2-legs)

| φD | W1 | W2 | A | B |
|----|------|-------|-----|---|
| 36 | 48 | 58 | 3.8 | 7 |
| 51 | 68 | 80 | 5 | 7 |
| 64 | 81 | 93 | 5 | 7 |
| 77 | 93.5 | 106 | 5 | 7 |
| 90 | 108 | 120.5 | 5 | 7 |

Code K (3-legs)

| φD | R1 | R2 | A | B |
|-----|------|------|---|---|
| 51 | 31.8 | 36.5 | 5 | 7 |
| 64 | 38.1 | 42.6 | 5 | 7 |
| 77 | 44.5 | 49.2 | 5 | 7 |
| 90 | 50.8 | 55.6 | 5 | 7 |
| 101 | 57.5 | 63.5 | 6 | 8 |

| φD | H |
|--------|----|
| 36 | 15 |
| 51~101 | 30 |

Part numbering system (example : 400V3300µF)

| | | | | | | | | |
|-------------|---|----------------------|---|--------------------------|------------------------------|---------------|-----------------|------------|
| LYX | — | 400 | V | 332 | M | DDO | B | |
| Series code | | Rated voltage symbol | | Rated capacitance symbol | Capacitance tolerance symbol | Casing symbol | Optional symbol | Clamp code |

Coefficient of Frequency for Rated Ripple Current

| Frequency (Hz) | 50 | 120 | 300 | 1k | 10k |
|-------------------|------|-----|------|------|------|
| Rated voltage (V) | | | | | |
| 350 to 450 | 0.80 | 1 | 1.10 | 1.30 | 1.40 |

NOTE : Design, Specifications are subject to change without notice. It is recommended that you shall obtain technical specifications from ELNA to ensure that the component is suitable for your use.

Standard Ratings

| 350V | | | | | | 400V | | | | | |
|---------------------------------|-----------|-----|---------------|-------------------|--------------------------------|---------------------------------|-----------|-----|---------------|-------------------|--------------------------------|
| Rated capacitance (μ F) | Case (mm) | | Casing symbol | ESR | Rated ripple current (Arms) | Rated capacitance (μ F) | Case (mm) | | Casing symbol | ESR | Rated ripple current (Arms) |
| | ϕ D | L | | (m Ω max.) | | | ϕ D | L | | (m Ω max.) | |
| 1000 | 51 | 75 | C75 | 259 | 3.9 | 1000 | 51 | 75 | C75 | 215 | 3.9 |
| 1200 | 51 | 75 | C75 | 215 | 4.2 | 1200 | 51 | 96 | C96 | 179 | 4.6 |
| 1500 | 51 | 96 | C96 | 172 | 5.2 | 1500 | 51 | 115 | CB5 | 143 | 5.6 |
| 1800 | 51 | 96 | C96 | 143 | 5.7 | 1800 | 51 | 130 | CD0 | 119 | 6.4 |
| 2200 | 51 | 130 | CD0 | 117 | 7.1 | 2200 | 64 | 96 | D96 | 98 | 6.9 |
| 2700 | 64 | 96 | D96 | 96 | 7.7 | 2700 | 64 | 115 | DB5 | 80 | 8.2 |
| 3300 | 64 | 115 | DB5 | 78 | 9.1 | 3300 | 64 | 130 | DD0 | 65 | 9.5 |
| 3900 | 64 | 130 | DD0 | 66 | 10.4 | 3900 | 64 | 155 | DF5 | 55 | 11.1 |
| 4700 | 64 | 155 | DF5 | 55 | 12.2 | | 77 | 115 | EB5 | 55 | 10.4 |
| | 77 | 115 | EB5 | 55 | 11.5 | 4700 | 64 | 195 | DJ5 | 46 | 13.4 |
| 5600 | 64 | 195 | DJ5 | 46 | 14.6 | | 77 | 130 | ED0 | 46 | 12.0 |
| | 77 | 130 | ED0 | 46 | 13.1 | 5600 | 64 | 195 | DJ5 | 39 | 14.6 |
| 6800 | 77 | 155 | EF5 | 38 | 15.5 | | 77 | 155 | EF5 | 39 | 14.0 |
| 8200 | 90 | 157 | FF7 | 31 | 18.1 | 6800 | 90 | 157 | FF7 | 32 | 16.5 |
| 10000 | 90 | 157 | FF7 | 26 | 19.9 | 8200 | 90 | 157 | FF7 | 26 | 18.1 |
| 12000 | 90 | 196 | FJ6 | 22 | 23.8 | 10000 | 90 | 196 | FJ6 | 22 | 21.7 |
| 15000 | 90 | 236 | FN6 | 17 | 28.8 | 12000 | 90 | 236 | FN6 | 18 | 25.8 |

| 450V | | | | | |
|---------------------------------|-----------|-----|---------------|-------------------|--------------------------------|
| Rated capacitance (μ F) | Case (mm) | | Casing symbol | ESR | Rated ripple current (Arms) |
| | ϕ D | L | | (m Ω max.) | |
| 1000 | 51 | 96 | C96 | 215 | 4.2 |
| 1200 | 51 | 115 | CB5 | 179 | 5.0 |
| 1500 | 51 | 130 | CD0 | 143 | 5.9 |
| 1800 | 64 | 96 | D96 | 119 | 6.3 |
| 2200 | 64 | 115 | DB5 | 98 | 7.4 |
| 2700 | 64 | 130 | DD0 | 80 | 8.6 |
| | 77 | 115 | EB5 | 80 | 8.7 |
| 3300 | 64 | 155 | DF5 | 65 | 10.2 |
| | 77 | 130 | ED0 | 65 | 10.1 |
| 3900 | 64 | 195 | DJ5 | 55 | 12.3 |
| 4700 | 77 | 155 | EF5 | 46 | 12.9 |
| 5600 | 77 | 195 | EJ5 | 38 | 15.4 |
| | 90 | 157 | FF7 | 38 | 14.9 |
| 6800 | 90 | 196 | FJ6 | 32 | 18.0 |
| 8200 | 90 | 196 | FJ6 | 27 | 19.8 |
| 10000 | 90 | 236 | FN6 | 22 | 23.6 |

(Note) Rated ripple current : 105°C , 120Hz ; ESR. : 20°C , 120Hz

Screw Terminal, Long Life capacitors

GREEN CAP 85°C 20000hours

- Screw Terminal, Long Life capacitors.
- Guarantees 20000 hours at 85°C.

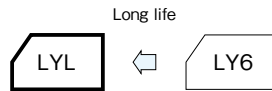

Marking color : Silver print on a black sleeve

Specifications

| Item | Performance | |
|--|--|---|
| Category temperature range (°C) | -40 to +85 | |
| Tolerance at rated capacitance (%) | ±20 (20°C,120Hz) | |
| Leakage current (µA) | Less than 0.01CV or 5mA whichever is smaller (after 5 minutes) C : Rated capacitance (µF) ; V : Rated voltage (V) (20°C) | |
| Tangent of loss angle (tanδ) | 0.20 (20°C,120Hz) | |
| Endurance (85°C) (Applied ripple current) | Test time | 20000 hours |
| | Leakage current | The initial specified value or less |
| | Percentage of capacitance change | Within ±20% of initial value |
| | Tangent of the loss angle | 200% or less of the initial specified value |
| Shelf life (85°C) | Test time | 1000 hours |
| | Leakage current | The initial specified value or less |
| | Percentage of capacitance change | Within ±20% of initial value |
| | Tangent of the loss angle | 200% or less of the initial specified value |
| Applicable standards | JIS C5101-1, -4 1998 (IEC 60384-1 1992, -4 1995) | |

Outline Drawing

Unit : mm

| φD | 36 | 51 | 64 | 77 | 90 | 101 |
|-----|------|------|------|------|------|------|
| F±1 | 12.7 | 22.0 | 28.2 | 31.4 | 31.4 | 41.5 |

Mounting Clamp

Unit : mm

Code J (2-legs)

| φD | W1 | W2 | A | B |
|----|------|-------|-----|---|
| 36 | 48 | 58 | 3.8 | 7 |
| 51 | 68 | 80 | 5 | 7 |
| 64 | 81 | 93 | 5 | 7 |
| 77 | 93.5 | 106 | 5 | 7 |
| 90 | 108 | 120.5 | 5 | 7 |

Code K (3-legs)

| φD | R1 | R2 | A | B |
|-----|------|------|---|---|
| 51 | 31.8 | 36.5 | 5 | 7 |
| 64 | 38.1 | 42.6 | 5 | 7 |
| 77 | 44.5 | 49.2 | 5 | 7 |
| 90 | 50.8 | 55.6 | 5 | 7 |
| 101 | 57.5 | 63.5 | 6 | 8 |

| φD | H |
|--------|----|
| 36 | 15 |
| 51~101 | 30 |

Part numbering system (example : 450V4700µF)

| | | | | | | | | |
|-------------|---|----------------------|---|--------------------------|------------------------------|---------------|-----------------|------------|
| LYL | — | 450 | V | 472 | M | EF5 | B | |
| Series code | | Rated voltage symbol | | Rated capacitance symbol | Capacitance tolerance symbol | Casing symbol | Optional symbol | Clamp code |

Coefficient of Frequency for Rated Ripple Current

| Frequency (Hz) | 50 | 120 | 300 | 1k | 10k |
|-------------------|------|-----|------|------|------|
| Rated voltage (V) | | | | | |
| 350 to 450 | 0.80 | 1 | 1.10 | 1.30 | 1.40 |

NOTE : Design, Specifications are subject to change without notice. It is recommended that you shall obtain technical specifications from ELNA to ensure that the component is suitable for your use.

Standard Ratings

| 350V | | | | | | 400V | | | | | |
|---------------------------------|-----------|-----|---------------|-------------------|--------------------------------|---------------------------------|-----------|-----|---------------|-------------------|--------------------------------|
| Rated capacitance (μ F) | Case (mm) | | Casing symbol | ESR | Rated ripple current (Arms) | Rated capacitance (μ F) | Case (mm) | | Casing symbol | ESR | Rated ripple current (Arms) |
| | ϕ D | L | | (m Ω max.) | | | ϕ D | L | | (m Ω max.) | |
| 1000 | 51 | 75 | C75 | 259 | 3.9 | 1000 | 51 | 75 | C75 | 215 | 3.9 |
| 1200 | 51 | 75 | C75 | 215 | 4.2 | 1200 | 51 | 96 | C96 | 179 | 4.6 |
| 1500 | 51 | 96 | C96 | 172 | 5.2 | 1500 | 51 | 115 | CB5 | 143 | 5.6 |
| 1800 | 51 | 96 | C96 | 143 | 5.7 | 1800 | 51 | 130 | CD0 | 119 | 6.4 |
| 2200 | 51 | 130 | CD0 | 117 | 7.1 | 2200 | 64 | 96 | D96 | 98 | 6.9 |
| 2700 | 64 | 96 | D96 | 96 | 7.7 | 2700 | 64 | 115 | DB5 | 80 | 8.2 |
| 3300 | 64 | 115 | DB5 | 78 | 9.1 | 3300 | 64 | 130 | DD0 | 65 | 9.5 |
| 3900 | 64 | 130 | DD0 | 66 | 10.4 | 3900 | 64 | 155 | DF5 | 55 | 11.1 |
| 4700 | 64 | 155 | DF5 | 55 | 12.2 | | 77 | 115 | EB5 | 55 | 10.4 |
| | 77 | 115 | EB5 | 55 | 11.5 | 4700 | 64 | 195 | DJ5 | 46 | 13.4 |
| 5600 | 64 | 195 | DJ5 | 46 | 14.6 | | 77 | 130 | ED0 | 46 | 12.0 |
| | 77 | 130 | ED0 | 46 | 13.1 | 5600 | 64 | 195 | DJ5 | 39 | 14.6 |
| 6800 | 77 | 155 | EF5 | 38 | 15.5 | | 77 | 155 | EF5 | 39 | 14.0 |
| 8200 | 90 | 157 | FF7 | 31 | 18.1 | 6800 | 90 | 157 | FF7 | 32 | 16.5 |
| 10000 | 90 | 157 | FF7 | 26 | 19.9 | 8200 | 90 | 157 | FF7 | 26 | 18.1 |
| 12000 | 90 | 196 | FJ6 | 22 | 23.8 | 10000 | 90 | 196 | FJ6 | 22 | 21.7 |
| 15000 | 90 | 236 | FN6 | 17 | 28.8 | 12000 | 90 | 236 | FN6 | 18 | 25.8 |

| 450V | | | | | |
|---------------------------------|-----------|-----|---------------|-------------------|--------------------------------|
| Rated capacitance (μ F) | Case (mm) | | Casing symbol | ESR | Rated ripple current (Arms) |
| | ϕ D | L | | (m Ω max.) | |
| 1000 | 51 | 96 | C96 | 215 | 4.2 |
| 1200 | 51 | 115 | CB5 | 179 | 5.0 |
| 1500 | 51 | 130 | CD0 | 143 | 5.9 |
| 1800 | 64 | 96 | D96 | 119 | 6.3 |
| 2200 | 64 | 115 | DB5 | 98 | 7.4 |
| 2700 | 64 | 130 | DD0 | 80 | 8.6 |
| | 77 | 115 | EB5 | 80 | 8.7 |
| 3300 | 64 | 155 | DF5 | 65 | 10.2 |
| | 77 | 130 | ED0 | 65 | 10.1 |
| 3900 | 64 | 195 | DJ5 | 55 | 12.3 |
| 4700 | 77 | 155 | EF5 | 46 | 12.9 |
| 5600 | 77 | 195 | EJ5 | 38 | 15.4 |
| | 90 | 157 | FF7 | 38 | 14.9 |
| 6800 | 90 | 196 | FJ6 | 32 | 18.0 |
| 8200 | 90 | 196 | FJ6 | 27 | 19.8 |
| 10000 | 90 | 236 | FN6 | 22 | 23.6 |

(Note) Rated ripple current : 85°C , 120Hz ; ESR. : 20°C , 120Hz

Screw Terminal, Miniaturized, High Ripple capacitors

GREEN CAP

85°C
5000hours

- Screw Terminal, Miniaturized, High Ripple capacitors.
- Guarantees 5000 hours at 85°C.

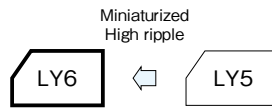

Marking color : Silver print on a black sleeve

Specifications

| Item | Performance | | |
|--|--|---|----------|
| Category temperature range (°C) | -25 to +85 | | |
| Tolerance at rated capacitance (%) | ±20 (20°C, 120Hz) | | |
| Leakage current (µA) | Less than 0.01CV or 5mA whichever is smaller (after 5 minutes) C : Rated capacitance (µF) ; V : Rated voltage (V) (20°C) | | |
| Tangent of loss angle (tanδ) | Rated voltage (V) | 400, 450 | 500, 550 |
| | tanδ (max.) | 0.15 | 0.20 |
| Endurance (85°C) (Applied ripple current) | Test time | 5000 hours | |
| | Leakage current | The initial specified value or less | |
| | Percentage of capacitance change | Within ±20% of initial value | |
| | Tangent of the loss angle | 200% or less of the initial specified value | |
| Shelf life (85°C) | Test time | 1000 hours | |
| | Leakage current | The initial specified value or less | |
| | Percentage of capacitance change | Within ±20% of initial value | |
| | Tangent of the loss angle | 200% or less of the initial specified value | |
| Applicable standards | JIS C5101-1, -4 1998 (IEC 60384-1 1992, -4 1995) | | |

Outline Drawing

Unit : mm

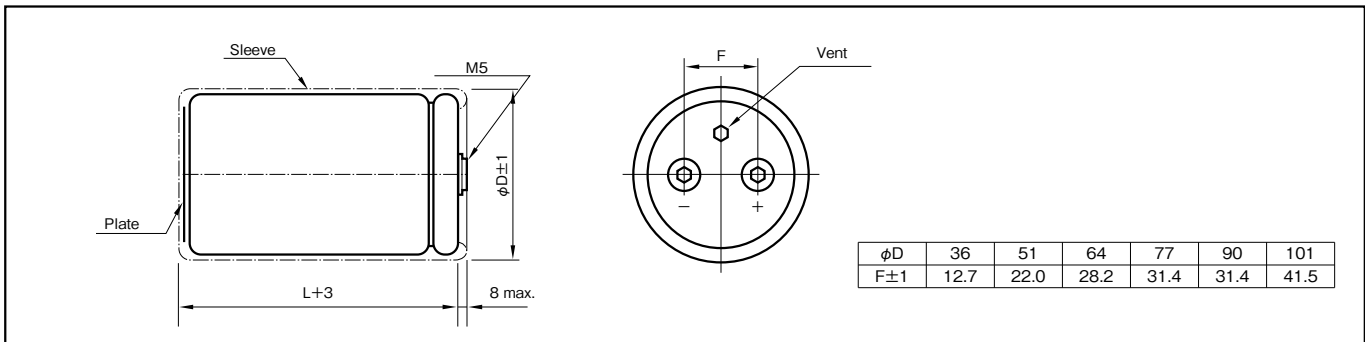

Mounting Clamp

Unit : mm

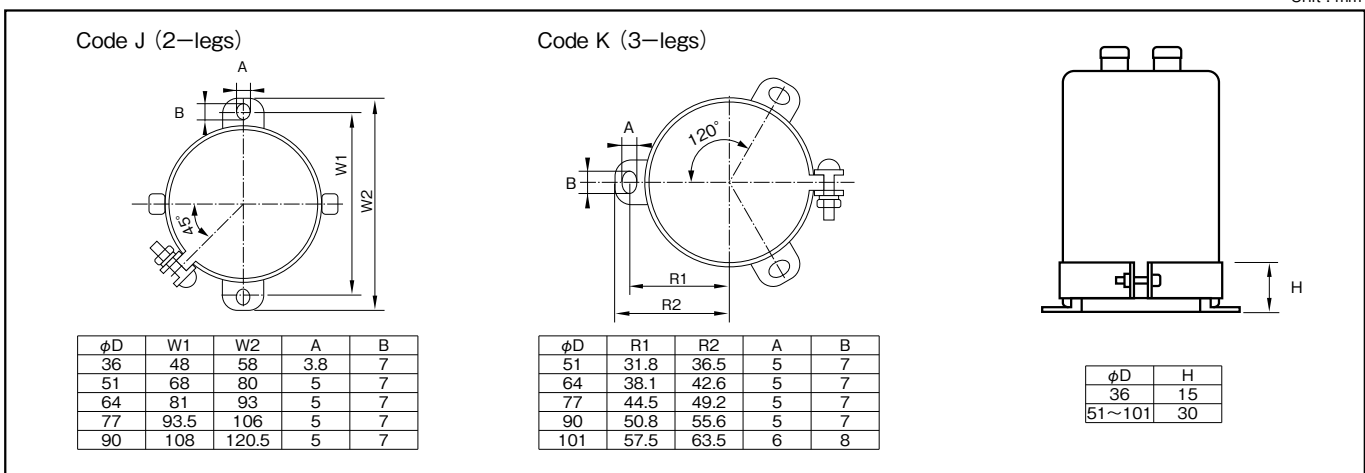

Part numbering system (example : 400V12000µF)

| | | | | | | | | |
|-------------|---|----------------------|---|--------------------------|------------------------------|---------------|-----------------|------------|
| LY6 | — | 400 | V | 123 | M | FF7 | B | |
| Series code | | Rated voltage symbol | | Rated capacitance symbol | Capacitance tolerance symbol | Casing symbol | Optional symbol | Clamp code |

Coefficient of Frequency for Rated Ripple Current

| Frequency (Hz) | 50 | 120 | 300 | 1k | 10k |
|-------------------|------|-----|------|------|------|
| Rated voltage (V) | | | | | |
| 400 to 550 | 0.80 | 1 | 1.10 | 1.30 | 1.40 |

NOTE : Design, Specifications are subject to change without notice.
It is recommended that you shall obtain technical specifications from ELNA to ensure that the component is suitable for your use.

Standard Ratings

| 400V | | | | | | 450V | | | | | |
|---------------------------------|-----------|-----|---------------|-------------------|--------------------------------|---------------------------------|-----------|-----|---------------|-------------------|--------------------------------|
| Rated capacitance (μ F) | Case (mm) | | Casing symbol | ESR | Rated ripple current (Arms) | Rated capacitance (μ F) | Case (mm) | | Casing symbol | ESR | Rated ripple current (Arms) |
| | ϕ D | L | | (m Ω max.) | | | ϕ D | L | | (m Ω max.) | |
| 2200 | 51 | 115 | CB5 | 98 | 8.8 | 1800 | 51 | 115 | CB5 | 119 | 7.6 |
| 2700 | 51 | 130 | CD0 | 80 | 10.2 | 2200 | 51 | 130 | CD0 | 98 | 8.8 |
| 3300 | 64 | 96 | D96 | 65 | 11.0 | 2700 | 64 | 96 | D96 | 80 | 9.5 |
| 3900 | 64 | 115 | DB5 | 55 | 12.8 | 3300 | 64 | 115 | DB5 | 65 | 11.2 |
| 4700 | 64 | 130 | DD0 | 46 | 14.8 | 3900 | 64 | 130 | DD0 | 55 | 12.8 |
| 5600 | 77 | 115 | EB5 | 38 | 16.2 | 4700 | 77 | 115 | EB5 | 46 | 14.1 |
| 6800 | 77 | 130 | ED0 | 32 | 18.7 | 5600 | 77 | 130 | ED0 | 38 | 16.2 |
| 8200 | 77 | 155 | EF5 | 26 | 22.0 | 6800 | 77 | 155 | EF5 | 32 | 19.1 |
| 10000 | 77 | 195 | EJ5 | 22 | 26.7 | 8200 | 77 | 195 | EJ5 | 26 | 23.0 |
| | 90 | 131 | FD1 | 22 | 24.2 | | 90 | 131 | FD1 | 26 | 21.0 |
| 12000 | 90 | 157 | FF7 | 18 | 28.5 | 10000 | 90 | 171 | FH1 | 22 | 25.7 |
| 15000 | 90 | 196 | FJ6 | 14 | 34.8 | 12000 | 90 | 196 | FJ6 | 18 | 29.7 |
| 18000 | 90 | 236 | FN6 | 12 | 41.2 | | 101 | 175 | GH5 | 18 | 29.3 |
| 22000 | 101 | 237 | GN7 | 10 | 47.0 | 15000 | 90 | 236 | FN6 | 14 | 35.9 |
| — | — | — | — | — | — | | 101 | 195 | GJ5 | 14 | 24.2 |
| — | — | — | — | — | — | | 18000 | 101 | 237 | GN7 | 12 |

| 500V | | | | | | 550V | | | | | |
|---------------------------------|-----------|-----|---------------|-------------------|--------------------------------|---------------------------------|-----------|-----|---------------|-------------------|--------------------------------|
| Rated capacitance (μ F) | Case (mm) | | Casing symbol | ESR | Rated ripple current (Arms) | Rated capacitance (μ F) | Case (mm) | | Casing symbol | ESR | Rated ripple current (Arms) |
| | ϕ D | L | | (m Ω max.) | | | ϕ D | L | | (m Ω max.) | |
| 1200 | 51 | 115 | CB5 | 215 | 6.2 | 1000 | 51 | 130 | CD0 | 258 | 5.9 |
| | 64 | 96 | D96 | 215 | 6.3 | 1200 | 64 | 115 | DB5 | 215 | 6.8 |
| 1500 | 51 | 130 | CD0 | 172 | 7.3 | 1500 | 64 | 130 | DD0 | 172 | 8.0 |
| | 64 | 96 | D96 | 172 | 7.1 | 1800 | 77 | 115 | EB5 | 143 | 8.7 |
| 1800 | 64 | 115 | DB5 | 143 | 8.3 | 2200 | 77 | 130 | ED0 | 117 | 10.1 |
| 2200 | 64 | 130 | DD0 | 117 | 9.6 | 2700 | 77 | 155 | EF5 | 96 | 12.0 |
| 2700 | 77 | 115 | EB5 | 96 | 10.7 | 3300 | 77 | 155 | EF5 | 78 | 13.3 |
| 3300 | 77 | 130 | ED0 | 78 | 12.4 | 3900 | 90 | 157 | FF7 | 66 | 15.5 |
| 3900 | 77 | 155 | EF5 | 66 | 14.4 | 4700 | 90 | 171 | FH1 | 55 | 17.6 |
| 4700 | 77 | 171 | EH1 | 55 | 16.5 | 5600 | 90 | 196 | FJ6 | 46 | 20.3 |
| | 90 | 131 | FD1 | 55 | 15.8 | 6800 | 90 | 236 | FN6 | 38 | 24.1 |
| 5600 | 77 | 195 | EJ5 | 46 | 19.0 | 8200 | 101 | 237 | GN7 | 31 | 27.3 |
| | 90 | 157 | FF7 | 46 | 18.6 | | | | | | |
| 6800 | 90 | 171 | FH1 | 38 | 21.2 | | | | | | |
| 8200 | 90 | 196 | FJ6 | 31 | 24.5 | | | | | | |
| | 101 | 175 | GH5 | 31 | 24.2 | | | | | | |
| 10000 | 90 | 236 | FN6 | 26 | 29.3 | | | | | | |
| | 101 | 195 | GJ5 | 26 | 27.9 | | | | | | |
| 12000 | 101 | 237 | GN7 | 22 | 33.1 | | | | | | |

(Note) Rated ripple current : 85°C , 120Hz ; ESR : 20°C , 120Hz

Screw Terminal, Standard capacitors

GREEN CAP 85°C 2000hours

- Screw Terminal, Standard capacitors.
- Guarantees 2000 hours at 85°C.

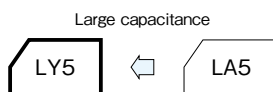

Marking color : Silver print on a black sleeve

Specifications

| Item | Performance | |
|--|--|---|
| Category temperature range (°C) | -40 to +85 | -25 to +85 |
| Rated voltage (V) | 10 to 250 | 350 to 500 |
| Tolerance at rated capacitance (%) | ±20 (20°C, 120Hz) | |
| Leakage current (µA) | Less than 0.01CV or 5mA whichever is smaller (after 5 minutes) C : Rated capacitance (µF) ; V : Rated voltage (V) (20°C) | |
| Tangent of loss angle (tanδ) | Refer to the following pages (20°C, 120Hz) | |
| Endurance (85°C) (Applied ripple current) | Test time | 2000 hours |
| | Leakage current | The initial specified value or less |
| | Percentage of capacitance change | Within ±20% of initial value |
| | Tangent of the loss angle | 200% or less of the initial specified value |
| Shelf life (85°C) | Test time | 1000 hours |
| | Leakage current | The initial specified value or less |
| | Percentage of capacitance change | Within ±20% of initial value |
| | Tangent of the loss angle | 200% or less of the initial specified value |
| Voltage application treatment | | |
| Applicable standards | JIS C5101-1, -4 1998 (IEC 60384-1 1992, -4 1995) | |

Outline Drawing

Unit : mm

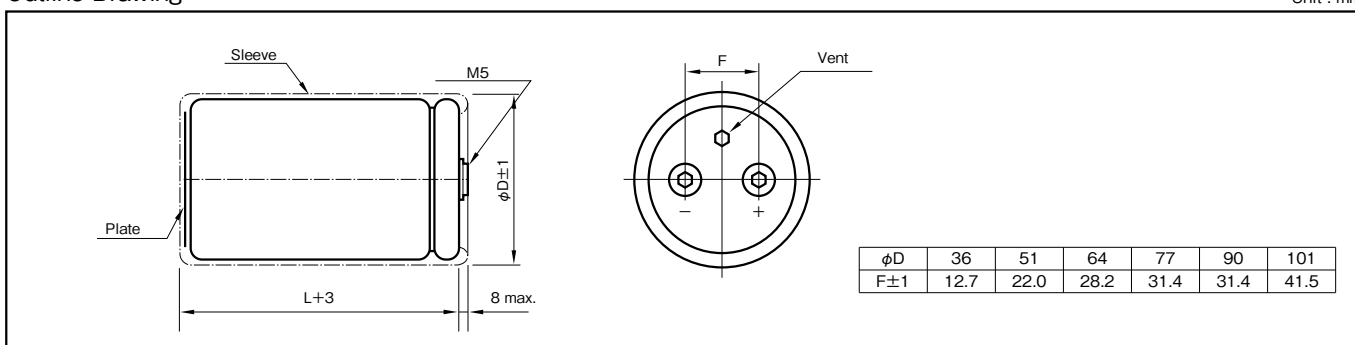

Mounting Clamp

Unit : mm

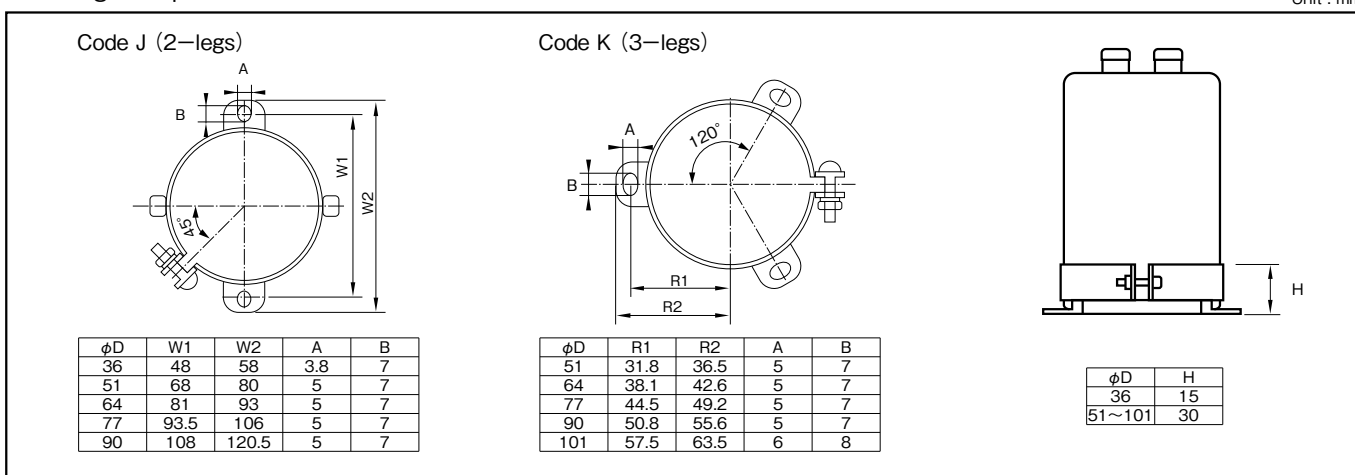

Part numbering system (example : 50V47000µF)

| | | | | | | | | |
|-------------|---|----------------------|---|--------------------------|------------------------------|---------------|-----------------|------------|
| LY5 | — | 50 | V | 473 | M | CB5 | B | □ |
| Series code | | Rated voltage symbol | | Rated capacitance symbol | Capacitance tolerance symbol | Casing symbol | Optional symbol | Clamp code |

Coefficient of Frequency for Rated Ripple Current

| Rated voltage (V) | Frequency (Hz) | | | | |
|-------------------|----------------|-----|------|------|------|
| | 50 | 120 | 300 | 1k | 10k |
| 10 to 50 | 0.95 | 1 | 1.04 | 1.10 | 1.15 |
| 63 to 160 | 0.95 | 1 | 1.06 | 1.16 | 1.30 |
| 200 to 500 | 0.80 | 1 | 1.10 | 1.25 | 1.50 |

Standard Ratings

| 10V | | | | | | 16V | | | | | | 25V | | | | | |
|---------------------------------|--------------|-----------|-----|---------------|--------------------------------|---------------------------------|--------------|-----------|-----|---------------|--------------------------------|---------------------------------|--------------|-----------|-----|---------------|--------------------------------|
| Rated capacitance (μ F) | tan δ | Case (mm) | | Casing symbol | Rated ripple current (Arms) | Rated capacitance (μ F) | tan δ | Case (mm) | | Casing symbol | Rated ripple current (Arms) | Rated capacitance (μ F) | tan δ | Case (mm) | | Casing symbol | Rated ripple current (Arms) |
| | | ϕ D | L | | | | | ϕ D | L | | | | | ϕ D | L | | |
| 33,000 | 0.80 | 36 | 53 | A53 | 4.3 | 22,000 | 0.60 | 36 | 53 | A53 | 4.1 | 15,000 | 0.50 | 36 | 53 | A53 | 3.7 |
| 39,000 | 0.80 | 36 | 53 | A53 | 4.7 | 27,000 | 0.60 | 36 | 53 | A53 | 4.5 | 18,000 | 0.50 | 36 | 53 | A53 | 4.1 |
| 47,000 | 0.80 | 36 | 65 | A65 | 5.2 | 33,000 | 0.60 | 36 | 53 | A53 | 5.0 | 22,000 | 0.50 | 36 | 53 | A53 | 4.5 |
| 56,000 | 0.80 | 36 | 83 | A83 | 6.1 | 39,000 | 0.60 | 36 | 65 | A65 | 5.9 | 27,000 | 0.50 | 36 | 65 | A65 | 5.0 |
| 68,000 | 0.80 | 36 | 83 | A83 | 6.7 | 47,000 | 0.60 | 36 | 83 | A83 | 6.4 | 33,000 | 0.50 | 36 | 83 | A83 | 5.9 |
| 82,000 | 0.80 | 36 | 100 | AA0 | 7.7 | 56,000 | 0.60 | 36 | 83 | A83 | 7.3 | 39,000 | 0.50 | 36 | 83 | A83 | 6.7 |
| 100,000 | 0.80 | 36 | 101 | AA1 | 8.8 | 68,000 | 0.60 | 36 | 100 | AA0 | 8.4 | 47,000 | 0.50 | 36 | 100 | AA0 | 7.7 |
| 120,000 | 0.80 | 36 | 121 | AC1 | 10.0 | 82,000 | 0.80 | 36 | 100 | AA0 | 8.3 | 56,000 | 0.60 | 36 | 100 | AA0 | 7.9 |
| 150,000 | 1.00 | 36 | 121 | AC1 | 10.8 | 100,000 | 0.80 | 36 | 121 | AC1 | 9.5 | 68,000 | 0.60 | 36 | 121 | AC1 | 9.2 |
| 180,000 | 1.00 | 51 | 96 | C96 | 12.0 | 120,000 | 0.80 | 36 | 121 | AC1 | 10.9 | 82,000 | 0.60 | 36 | 121 | AC1 | 10.4 |
| 220,000 | 1.50 | 51 | 121 | CC1 | 11.2 | 150,000 | 1.00 | 51 | 96 | C96 | 11.3 | 100,000 | 0.60 | 51 | 96 | C96 | 10.3 |
| 270,000 | 1.50 | 51 | 122 | CC2 | 12.8 | 180,000 | 1.00 | 51 | 115 | CB5 | 12.8 | 120,000 | 0.80 | 51 | 115 | CB5 | 11.7 |
| 330,000 | 1.50 | 64 | 96 | D96 | 15.3 | 220,000 | 1.00 | 51 | 130 | CD0 | 15.3 | 150,000 | 0.80 | 51 | 130 | CD0 | 14.1 |
| 390,000 | 1.50 | 64 | 115 | DB5 | 17.3 | 270,000 | 1.00 | 64 | 96 | D96 | 17.6 | 180,000 | 0.80 | 64 | 96 | D96 | 15.7 |
| 470,000 | 2.00 | 64 | 130 | DD0 | 16.7 | 330,000 | 1.50 | 64 | 115 | DB5 | 16.8 | 220,000 | 1.00 | 64 | 115 | DB5 | 16.1 |
| 560,000 | 2.00 | 77 | 115 | EB5 | 19.0 | 390,000 | 1.50 | 64 | 130 | DD0 | 18.3 | 270,000 | 1.00 | 64 | 130 | DD0 | 18.6 |
| 680,000 | 2.00 | 77 | 130 | ED0 | 21.7 | 470,000 | 1.50 | 77 | 115 | EB5 | 21.3 | 330,000 | 1.00 | 64 | 155 | DF5 | 21.9 |
| 820,000 | 2.00 | 77 | 155 | EF5 | 24.7 | 560,000 | 1.50 | 77 | 130 | ED0 | 23.6 | 390,000 | 1.20 | 77 | 115 | EB5 | 22.0 |
| — | — | — | — | — | — | 680,000 | 1.50 | 77 | 155 | EF5 | 27.6 | 470,000 | 1.20 | 77 | 155 | EF5 | 25.6 |
| — | — | — | — | — | — | 820,000 | 2.00 | 90 | 157 | FF7 | 27.1 | 560,000 | 1.20 | 90 | 131 | FD1 | 27.9 |
| — | — | — | — | — | — | — | — | — | — | — | — | 680,000 | 1.20 | 90 | 157 | FF7 | 32.5 |

| 35V | | | | | | 50V | | | | | | 63V | | | | | |
|---------------------------------|--------------|-----------|-----|---------------|--------------------------------|---------------------------------|--------------|-----------|-----|---------------|--------------------------------|---------------------------------|--------------|-----------|-----|---------------|--------------------------------|
| Rated capacitance (μ F) | tan δ | Case (mm) | | Casing symbol | Rated ripple current (Arms) | Rated capacitance (μ F) | tan δ | Case (mm) | | Casing symbol | Rated ripple current (Arms) | Rated capacitance (μ F) | tan δ | Case (mm) | | Casing symbol | Rated ripple current (Arms) |
| | | ϕ D | L | | | | | ϕ D | L | | | | | ϕ D | L | | |
| 10,000 | 0.40 | 36 | 53 | A53 | 3.4 | 5,600 | 0.30 | 36 | 53 | A53 | 3.0 | 3,900 | 0.25 | 36 | 53 | A53 | 2.7 |
| 12,000 | 0.40 | 36 | 53 | A53 | 3.7 | 6,800 | 0.30 | 36 | 53 | A53 | 3.3 | 4,700 | 0.25 | 36 | 53 | A53 | 3.0 |
| 15,000 | 0.40 | 36 | 65 | A65 | 4.2 | 8,200 | 0.30 | 36 | 53 | A53 | 3.6 | 5,600 | 0.25 | 36 | 53 | A53 | 3.3 |
| 18,000 | 0.40 | 36 | 83 | A83 | 4.7 | 10,000 | 0.30 | 36 | 65 | A65 | 4.0 | 6,800 | 0.25 | 36 | 65 | A65 | 3.6 |
| 22,000 | 0.40 | 36 | 83 | A83 | 5.7 | 12,000 | 0.30 | 36 | 83 | A83 | 4.7 | 8,200 | 0.25 | 36 | 83 | A83 | 4.3 |
| 27,000 | 0.40 | 36 | 100 | AA0 | 6.3 | 15,000 | 0.30 | 36 | 83 | A83 | 5.5 | 10,000 | 0.25 | 36 | 83 | A83 | 4.9 |
| 33,000 | 0.40 | 36 | 100 | AA0 | 7.2 | 18,000 | 0.30 | 36 | 100 | AA0 | 6.2 | 12,000 | 0.25 | 36 | 100 | AA0 | 5.6 |
| 39,000 | 0.50 | 36 | 121 | AC1 | 8.3 | 22,000 | 0.40 | 36 | 121 | AC1 | 6.3 | 15,000 | 0.30 | 36 | 100 | AA0 | 5.9 |
| 47,000 | 0.50 | 51 | 96 | C96 | 8.7 | 27,000 | 0.40 | 36 | 121 | AC1 | 7.1 | 18,000 | 0.30 | 36 | 121 | AC1 | 6.7 |
| 56,000 | 0.60 | 51 | 96 | C96 | 8.6 | 33,000 | 0.40 | 51 | 96 | C96 | 8.2 | 22,000 | 0.30 | 36 | 121 | AC1 | 7.8 |
| 68,000 | 0.60 | 51 | 115 | CB5 | 9.8 | 39,000 | 0.50 | 51 | 96 | C96 | 8.1 | 27,000 | 0.40 | 51 | 96 | C96 | 7.4 |
| 82,000 | 0.60 | 64 | 96 | D96 | 11.6 | 47,000 | 0.50 | 51 | 115 | CB5 | 9.3 | 33,000 | 0.40 | 51 | 96 | C96 | 8.4 |
| 100,000 | 0.60 | 64 | 115 | DB5 | 13.3 | 56,000 | 0.50 | 64 | 96 | D96 | 10.5 | 39,000 | 0.40 | 51 | 115 | CB5 | 9.5 |
| 120,000 | 0.80 | 64 | 121 | DC1 | 14.8 | 68,000 | 0.50 | 64 | 96 | D96 | 12.0 | 47,000 | 0.40 | 51 | 130 | CD0 | 11.3 |
| 150,000 | 0.80 | 64 | 130 | DD0 | 14.9 | 82,000 | 0.50 | 64 | 115 | DB5 | 13.7 | 56,000 | 0.40 | 64 | 115 | DB5 | 12.8 |
| 180,000 | 0.80 | 77 | 115 | EB5 | 17.0 | 100,000 | 0.60 | 77 | 115 | EB5 | 14.7 | 68,000 | 0.50 | 64 | 121 | DC1 | 12.7 |
| 220,000 | 0.80 | 77 | 130 | ED0 | 20.0 | 120,000 | 0.60 | 77 | 115 | EB5 | 16.7 | 82,000 | 0.50 | 64 | 130 | DD0 | 14.5 |
| 270,000 | 1.00 | 77 | 155 | EF5 | 20.3 | 150,000 | 0.60 | 77 | 130 | ED0 | 19.3 | 100,000 | 0.50 | 77 | 115 | EB5 | 16.7 |
| 330,000 | 1.00 | 90 | 131 | FD1 | 23.5 | 180,000 | 0.60 | 77 | 155 | EF5 | 21.9 | 120,000 | 0.50 | 77 | 130 | ED0 | 18.9 |
| 390,000 | 1.00 | 90 | 157 | FF7 | 26.4 | 220,000 | 0.60 | 90 | 131 | FD1 | 21.4 | 150,000 | 0.50 | 77 | 155 | EF5 | 22.4 |
| 470,000 | 1.00 | 90 | 157 | FF7 | 29.6 | 270,000 | 0.60 | 90 | 157 | FF7 | 24.6 | 180,000 | 0.60 | 90 | 131 | FD1 | 22.4 |
| — | — | — | — | — | — | — | — | — | — | — | — | 220,000 | 0.60 | 90 | 157 | FF7 | 26.2 |

| 80V | | | | | | 100V | | | | | |
|---------------------------------|--------------|-----------|-----|---------------|--------------------------------|---------------------------------|--------------|-----------|-----|---------------|--------------------------------|
| Rated capacitance (μ F) | tan δ | Case (mm) | | Casing symbol | Rated ripple current (Arms) | Rated capacitance (μ F) | tan δ | Case (mm) | | Casing symbol | Rated ripple current (Arms) |
| | | ϕ D | L | | | | | ϕ D | L | | |
| 3,300 | 0.25 | 36 | 53 | A53 | 2.5 | 1,800 | 0.25 | 36 | 53 | A53 | 1.9 |
| 3,900 | 0.25 | 36 | 53 | A53 | 2.8 | 2,200 | 0.25 | 36 | 53 | A53 | 2.1 |
| 4,700 | 0.25 | 36 | 65 | A65 | 3.0 | 2,700 | 0.25 | 36 | 53 | A53 | 2.3 |
| 5,600 | 0.25 | 36 | 83 | A83 | 3.6 | 3,300 | 0.25 | 36 | 65 | A65 | 2.6 |
| 6,800 | 0.25 | 36 | 83 | A83 | 3.9 | 3,900 | 0.25 | 36 | 83 | A83 | 3.0 |
| 8,200 | 0.25 | 36 | 83 | A83 | 4.5 | 4,700 | 0.25 | 36 | 83 | A83 | 3.5 |
| 10,000 | 0.25 | 36 | 100 | AA0 | 5.2 | 5,600 | 0.25 | 36 | 100 | AA0 | 3.9 |
| 12,000 | 0.25 | 36 | 100 | AA0 | 5.9 | 6,800 | 0.25 | 36 | 100 | AA0 | 4.5 |
| 15,000 | 0.25 | 36 | 121 | AC1 | 6.8 | 8,200 | 0.25 | 36 | 121 | AC1 | 5.1 |
| 18,000 | 0.25 | 36 | 121 | AC1 | 7.8 | 10,000 | 0.25 | 36 | 121 | AC1 | 5.9 |
| 22,000 | 0.30 | 51 | 96 | C96 | 8.0 | 12,000 | 0.25 | 51 | 75 | C75 | 6.4 |
| 27,000 | 0.30 | 51 | 96 | C96 | 9.2 | 15,000 | 0.25 | 51 | 96 | C96 | 7.0 |
| 33,000 | 0.30 | 51 | 115 | CB5 | 10.5 | 18,000 | 0.25 | 51 | 115 | CB5 | 8.3 |
| 39,000 | 0.30 | 51 | 130 | CD0 | 12.0 | 22,000 | 0.25 | 51 | 130 | CD0 | 10.0 |
| 47,000 | 0.30 | 64 | 115 | DB5 | 13.6 | 27,000 | 0.25 | 64 | 115 | DB5 | 11.5 |
| 56,000 | 0.40 | 64 | 130 | DD0 | 13.4 | 33,000 | 0.25 | 64 | 130 | DD0 | 11.9 |
| 68,000 | 0.40 | 77 | 115 | EB5 | 15.4 | 39,000 | 0.25 | 77 | 115 | EB5 | 13.4 |
| 82,000 | 0.40 | 77 | 130 | ED0 | 17.5 | 47,000 | 0.35 | 77 | 130 | ED0 | 14.2 |
| 100,000 | 0.40 | 77 | 155 | EF5 | 20.5 | 56,000 | 0.35 | 77 | 155 | EF5 | 16.0 |
| 120,000 | 0.40 | 90 | 131 | FD1 | 22.4 | 68,000 | 0.35 | 90 | 131 | FD1 | 18.8 |
| 150,000 | 0.40 | 90 | 157 | FF7 | 26.5 | 82,000 | 0.35 | 90 | 157 | FF7 | 20.5 |
| — | — | — | — | — | — | 100,000 | 0.35 | 90 | 171 | FH1 | 24.0 |

(Note) Rated ripple current : 85°C, 120Hz; ESR : 20°C, 120Hz

• The standard ratings follow the next page.

NOTE : Design, Specifications are subject to change without notice.
It is recommended that you shall obtain technical specifications from ELNA to ensure that the component is suitable for your use.

Standard Ratings

| 160V | | | | | | 200V | | | | | | 250V | | | | | |
|------------------------|-------|-----------|-----|---------------|-----------------------------|------------------------|-------|-----------|-----|---------------|-----------------------------|------------------------|-------|-----------|-----|---------------|-----------------------------|
| Rated capacitance (μF) | tan δ | Case (mm) | | Casing symbol | Rated ripple current (Arms) | Rated capacitance (μF) | tan δ | Case (mm) | | Casing symbol | Rated ripple current (Arms) | Rated capacitance (μF) | tan δ | Case (mm) | | Casing symbol | Rated ripple current (Arms) |
| | | φD | L | | | | | φD | L | | | | | φD | L | | |
| 3,300 | 0.25 | 36 | 121 | AC1 | 5.2 | 2,200 | 0.25 | 36 | 100 | AA0 | 3.9 | 1,500 | 0.25 | 36 | 100 | AA0 | 3.2 |
| 4,700 | 0.25 | 51 | 75 | C75 | 5.9 | 3,300 | 0.25 | 51 | 75 | C75 | 4.9 | 2,200 | 0.25 | 51 | 75 | C75 | 4.0 |
| 5,600 | 0.25 | 51 | 96 | C96 | 7.0 | 4,700 | 0.25 | 51 | 96 | C96 | 6.4 | 3,300 | 0.25 | 51 | 96 | C96 | 5.4 |
| 6,800 | 0.25 | 51 | 96 | C96 | 7.8 | 5,600 | 0.25 | 51 | 115 | CB5 | 7.6 | 4,700 | 0.25 | 64 | 96 | D96 | 7.1 |
| 10,000 | 0.25 | 64 | 96 | D96 | 10.4 | 6,800 | 0.25 | 51 | 130 | CD0 | 8.8 | 6,800 | 0.25 | 64 | 115 | DB5 | 9.1 |
| 12,000 | 0.25 | 51 | 120 | CC0 | 11.3 | 8,200 | 0.25 | 64 | 96 | D96 | 9.4 | 8,200 | 0.25 | 64 | 115 | DB5 | 10.0 |
| 15,000 | 0.25 | 64 | 130 | DD0 | 14.3 | 10,000 | 0.25 | 64 | 96 | D96 | 10.4 | 10,000 | 0.25 | 64 | 130 | DD0 | 11.7 |
| 18,000 | 0.25 | 64 | 130 | DD0 | 15.6 | 15,000 | 0.25 | 77 | 96 | E96 | 14.4 | 15,000 | 0.25 | 77 | 130 | ED0 | 15.1 |
| 22,000 | 0.25 | 77 | 130 | ED0 | 18.3 | 18,000 | 0.25 | 77 | 130 | ED0 | 16.5 | 18,000 | 0.25 | 77 | 155 | EF5 | 17.7 |
| 33,000 | 0.25 | 90 | 131 | FD1 | 23.8 | 22,000 | 0.25 | 77 | 150 | EF0 | 19.6 | 22,000 | 0.25 | 90 | 157 | FF7 | 20.9 |
| 39,000 | 0.25 | 90 | 157 | FF7 | 27.9 | 33,000 | 0.25 | 90 | 157 | FF7 | 25.3 | — | — | — | — | — | — |

| 350V | | | | | | 400V | | | | | | 450V | | | | | |
|------------------------|-------|-----------|-----|---------------|-----------------------------|------------------------|-------|-----------|-----|---------------|-----------------------------|------------------------|-------|-----------|-----|---------------|-----------------------------|
| Rated capacitance (μF) | tan δ | Case (mm) | | Casing symbol | Rated ripple current (Arms) | Rated capacitance (μF) | tan δ | Case (mm) | | Casing symbol | Rated ripple current (Arms) | Rated capacitance (μF) | tan δ | Case (mm) | | Casing symbol | Rated ripple current (Arms) |
| | | φD | L | | | | | φD | L | | | | | φD | L | | |
| 470 | 0.20 | 36 | 83 | A83 | 2.2 | 470 | 0.20 | 36 | 83 | A83 | 2.2 | 470 | 0.20 | 36 | 83 | A83 | 2.2 |
| 680 | 0.20 | 36 | 83 | A83 | 2.6 | 680 | 0.20 | 36 | 100 | AA0 | 2.8 | 680 | 0.20 | 36 | 100 | AA0 | 2.8 |
| 1,000 | 0.20 | 36 | 100 | AA0 | 3.4 | 1,000 | 0.20 | 51 | 75 | C75 | 3.5 | 820 | 0.20 | 51 | 75 | C75 | 3.2 |
| 1,500 | 0.20 | 51 | 75 | C75 | 4.3 | 1,200 | 0.20 | 51 | 75 | C75 | 3.8 | 1,000 | 0.20 | 51 | 75 | C75 | 3.5 |
| 1,800 | 0.20 | 51 | 96 | C96 | 5.1 | 1,500 | 0.20 | 51 | 96 | C96 | 4.7 | 1,200 | 0.20 | 51 | 96 | C96 | 4.2 |
| 2,200 | 0.20 | 51 | 96 | C96 | 5.7 | 1,800 | 0.20 | 51 | 96 | C96 | 5.2 | 1,500 | 0.20 | 51 | 115 | CB5 | 5.0 |
| 2,700 | 0.20 | 51 | 130 | CD0 | 7.1 | 2,200 | 0.20 | 51 | 120 | CC0 | 6.4 | 1,800 | 0.20 | 51 | 130 | CD0 | 5.9 |
| 3,300 | 0.20 | 51 | 130 | CD0 | 7.9 | 2,700 | 0.20 | 64 | 96 | D96 | 7.0 | 2,200 | 0.20 | 64 | 96 | D96 | 6.3 |
| 3,900 | 0.20 | 64 | 115 | DB5 | 9.0 | 3,300 | 0.20 | 64 | 115 | DB5 | 8.2 | 2,700 | 0.20 | 64 | 115 | DB5 | 7.5 |
| 4,700 | 0.20 | 64 | 130 | DD0 | 10.3 | 3,900 | 0.20 | 64 | 130 | DD0 | 9.4 | 3,300 | 0.20 | 64 | 130 | DD0 | 8.7 |
| 5,600 | 0.20 | 77 | 115 | EB5 | 11.4 | 4,700 | 0.20 | 77 | 115 | EB5 | 10.4 | 3,900 | 0.20 | 77 | 115 | EB5 | 9.5 |
| 6,800 | 0.20 | 77 | 130 | ED0 | 13.1 | 5,600 | 0.20 | 77 | 130 | ED0 | 11.9 | 4,700 | 0.20 | 77 | 130 | ED0 | 10.9 |
| 8,200 | 0.20 | 77 | 155 | EF5 | 15.4 | 6,800 | 0.20 | 77 | 155 | EF5 | 14.1 | 5,600 | 0.20 | 77 | 155 | EF5 | 12.8 |
| 10,000 | 0.20 | 90 | 157 | FF7 | 18.1 | 8,200 | 0.20 | 90 | 157 | FF7 | 16.4 | 6,800 | 0.20 | 90 | 157 | FF7 | 15.0 |
| 12,000 | 0.20 | 90 | 157 | FF7 | 20.0 | 10,000 | 0.20 | 90 | 157 | FF7 | 18.3 | 8,200 | 0.20 | 90 | 157 | FF7 | 16.5 |
| 15,000 | 0.20 | 90 | 196 | FJ6 | 24.5 | 12,000 | 0.20 | 90 | 196 | FJ6 | 21.8 | 10,000 | 0.20 | 90 | 196 | FJ6 | 20.0 |
| 18,000 | 0.20 | 90 | 236 | FN6 | 28.8 | 15,000 | 0.20 | 90 | 236 | FN6 | 26.3 | 12,000 | 0.20 | 90 | 236 | FN6 | 23.6 |

| 500V | | | | | |
|------------------------|-------|-----------|-----|---------------|-----------------------------|
| Rated capacitance (μF) | tan δ | Case (mm) | | Casing symbol | Rated ripple current (Arms) |
| | | φD | L | | |
| 1,000 | 0.25 | 51 | 115 | CB5 | 4.6 |
| 1,500 | 0.25 | 64 | 96 | D96 | 5.7 |
| 2,200 | 0.25 | 64 | 130 | DD0 | 6.9 |
| 2,700 | 0.25 | 77 | 115 | EB5 | 8.1 |
| 3,300 | 0.25 | 77 | 130 | ED0 | 9.6 |
| 3,900 | 0.25 | 77 | 130 | ED0 | 10.8 |
| 4,700 | 0.25 | 77 | 155 | EF5 | 12.1 |
| 5,600 | 0.25 | 90 | 157 | FF7 | 13.8 |
| 6,800 | 0.25 | 90 | 171 | FH1 | 15.8 |
| 8,200 | 0.25 | 77 | 220 | EM0 | 17.2 |
| 10,000 | 0.25 | 90 | 236 | FN6 | 22.1 |

(Note) Rated ripple current : 85°C , 120Hz ; ESR : 20°C , 120Hz

LARGE ALUMINUM

Aluminum Electrolytic Capacitors for Audio

Chip Type Audio Use Capacitors

GREEN CAP

SMD

For Audio

- Audio grade surface mount product with completely new components using synthetic mica paper for the separator.
- Both quality sense and sound field that could not be realized by the surface mount products are reproducible.



Marking color : Black print (except height : 10mm)
White print on a brown sleeve (φ8×10L, φ10×10L)

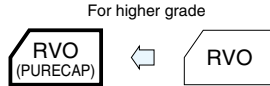

Specifications

| Item | Performance | | | | | | |
|--|---|---|------|------|------|------|------|
| Category temperature range (°C) | -40 to +85 | | | | | | |
| Tolerance at rated capacitance (%) | ±20 (20°C, 120Hz) | | | | | | |
| Leakage current (μA) | Less than 0.01CV or 3 whichever is larger (after 2 minutes) C : Rated capacitance (μF) ; V : Rated voltage (V) (20°C) | | | | | | |
| Tangent of loss angle (tanδ) | Rated voltage (V) | 6.3 | 10 | 16 | 25 | 35 | 50 |
| | tanδ (max.) | 0.28 | 0.24 | 0.20 | 0.14 | 0.12 | 0.10 |
| Characteristics at high and low temperature | Impedance ratio (max.) | Z-25°C/Z+20°C | 3 | 3 | 2 | 2 | 2 |
| | | Z-40°C/Z+20°C | 8 | 5 | 4 | 3 | 3 |
| Endurance (85°C) (Applied ripple current) | Test time | 2000 hours | | | | | |
| | Leakage current | The initial specified value or less | | | | | |
| | Percentage of capacitance change | Within ±20% of initial value | | | | | |
| | Tangent of the loss angle | 200% or less of the initial specified value | | | | | |
| Shelf life (85°C) | Test time : 1000 hours; other items are the same as those for the endurance. Voltage application treatment : According to JIS C5101 -1 | | | | | | |
| Applicable standards | JIS C5101-1 1998, -18 1999 (IEC 60384-1 1992, -18 1993) | | | | | | |

Outline Drawing

Unit : mm

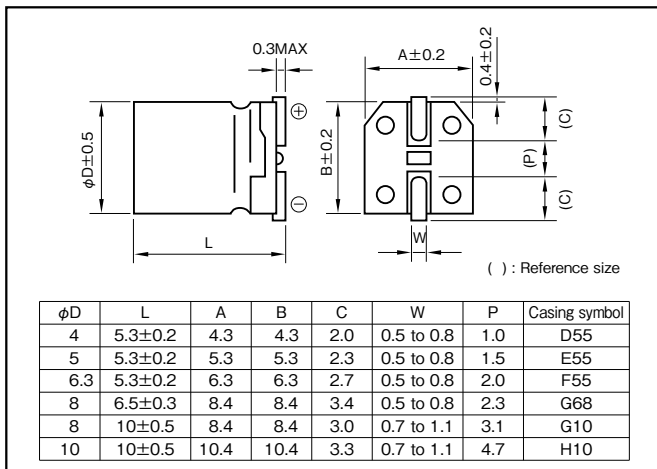

Coefficient of Frequency for Rated Ripple Current

| Frequency (Hz) | 50 | 120 | 1k | 10k-100k |
|-------------------|------|-----|------|----------|
| Rated voltage (V) | | | | |
| 6.3 to 16 | 0.80 | 1 | 1.15 | 1.25 |
| 25 to 35 | 0.80 | 1 | 1.25 | 1.40 |
| 50 | 0.80 | 1 | 1.35 | 1.50 |

Part numbering system (example : 16V470μF)

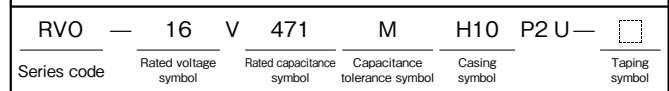

• Soldering conditions are described on page 13. • Land pattern size are described on page 11. • The taping specifications are described on page 14.

Standard Ratings

| Rated voltage (V) | 6.3 | | 10 | | 16 | | 25 | | 35 | | 50 | |
|------------------------|-----------|----------------------|-----------|----------------------|-----------|----------------------|-----------|----------------------|-----------|----------------------|-----------|----------------------|
| | Case | Rated ripple current | Case | Rated ripple current | Case | Rated ripple current | Case | Rated ripple current | Case | Rated ripple current | Case | Rated ripple current |
| Rated capacitance (μF) | φD×L (mm) | (mArms) | φD×L (mm) | (mArms) | φD×L (mm) | (mArms) | φD×L (mm) | (mArms) | φD×L (mm) | (mArms) | φD×L (mm) | (mArms) |
| 0.33 | — | — | — | — | — | — | — | — | — | — | 4×5.3 | 6 |
| 0.47 | — | — | — | — | — | — | — | — | — | — | 4×5.3 | 7 |
| 1 | — | — | — | — | — | — | — | — | — | — | 4×5.3 | 10 |
| 2.2 | — | — | — | — | — | — | — | — | — | — | 4×5.3 | 15 |
| 3.3 | — | — | — | — | — | — | — | — | 4×5.3 | 17 | 4×5.3 | 19 |
| 4.7 | — | — | — | — | 4×5.3 | 18 | 4×5.3 | 19 | 4×5.3 | 20 | 5×5.3 | 26 |
| 10 | — | — | 4×5.3 | 23 | 4×5.3 | 26 | 5×5.3 | 32 | 5×5.3 | 34 | 6.3×5.3 | 44 |
| 22 | 4×5.3 | 31 | 5×5.3 | 40 | 5×5.3 | 44 | 6.3×5.3 | 55 | 6.3×5.3 | 59 | 8×6.5 | 124 |
| 33 | 5×5.3 | 44 | 5×5.3 | 49 | 6.3×5.3 | 63 | 6.3×5.3 | 67 | 8×6.5 | 124 | 8×6.5 | 124 |
| 47 | 5×5.3 | 53 | 6.3×5.3 | 68 | 6.3×5.3 | 76 | 8×6.5 | 124 | 8×6.5 | 124 | 8×10 | 200 |
| 100 | 6.3×5.3 | 90 | 6.3×5.3 | 99 | 8×6.5 | 124 | 8×6.5 | 137 | 8×10 | 200 | 10×10 | 366 |
| 220 | 8×6.5 | 149 | 8×6.5 | 149 | 8×10 | 200 | 8×10 | 235 | 10×10 | 366 | — | — |
| 330 | 8×6.5 | 160 | 8×10 | 226 | 8×10 | 245 | 10×10 | 366 | — | — | — | — |
| 470 | 8×10 | 251 | 10×10 | 366 | 10×10 | 366 | — | — | — | — | — | — |
| 1000 | 10×10 | 423 | — | — | — | — | — | — | — | — | — | — |

(Note) Rated ripple current : 85°C, 120Hz.

Chip Type, For Audio, High Grade (SILMIC) Capacitors

GREEN CAP

SMD

For Audio

- Silk fiber paper products used surface mount device.
- Completely new audio products for the high-grade paper using silk fiber paper.
- Silk "flexibility" to reduce the vibration energy of the music, in the sense of high-frequency peak, a significant decrease in roughness of the midrange and bass increase.

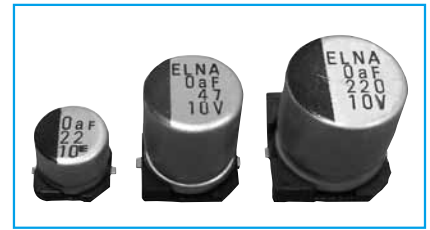

Marking color : Black print

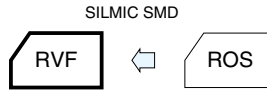

Specifications

| Item | Performance | | | | | | | | | | | |
|---|--|-------------------|------------|-----------------|-------------------------------------|----------------------------------|------------------------------|---------------------------|---|---------------|---|---|
| Category temperature range (°C) | -40 to +85 | | | | | | | | | | | |
| Tolerance at rated capacitance (%) | ±20 (20°C, 120Hz) | | | | | | | | | | | |
| Leakage current (µA) | Less than 0.01CV or 3 whichever is larger (after 2 minutes) C : Rated capacitance (µF) , V : Rated voltage (V) (20°C) | | | | | | | | | | | |
| Tangent of loss angle (tanδ) | <table border="1"> <tr> <th>Rated voltage (V)</th> <td>10</td> <td>16</td> <td>50</td> </tr> <tr> <td>tanδ (max.)</td> <td>0.32</td> <td>0.26</td> <td>0.12</td> </tr> </table> (20°C, 120Hz) | Rated voltage (V) | 10 | 16 | 50 | tanδ (max.) | 0.32 | 0.26 | 0.12 | | | |
| Rated voltage (V) | 10 | 16 | 50 | | | | | | | | | |
| tanδ (max.) | 0.32 | 0.26 | 0.12 | | | | | | | | | |
| Characteristics at high and low temperature | <table border="1"> <tr> <th>Rated voltage (V)</th> <td>10</td> <td>16</td> <td>50</td> </tr> <tr> <td rowspan="2">Impedance ratio (max.)</td> <td>Z-25°C/Z+20°C</td> <td>3</td> <td>2</td> </tr> <tr> <td>Z-40°C/Z+20°C</td> <td>8</td> <td>4</td> </tr> </table> (120Hz) | Rated voltage (V) | 10 | 16 | 50 | Impedance ratio (max.) | Z-25°C/Z+20°C | 3 | 2 | Z-40°C/Z+20°C | 8 | 4 |
| Rated voltage (V) | 10 | 16 | 50 | | | | | | | | | |
| Impedance ratio (max.) | Z-25°C/Z+20°C | 3 | 2 | | | | | | | | | |
| | Z-40°C/Z+20°C | 8 | 4 | | | | | | | | | |
| Endurance (85°C) | <table border="1"> <tr> <td>Test time</td> <td>2000 hours</td> </tr> <tr> <td>Leakage current</td> <td>The initial specified value or less</td> </tr> <tr> <td>Percentage of capacitance change</td> <td>Within ±20% of initial value</td> </tr> <tr> <td>Tangent of the loss angle</td> <td>200% or less of the initial specified value</td> </tr> </table> | Test time | 2000 hours | Leakage current | The initial specified value or less | Percentage of capacitance change | Within ±20% of initial value | Tangent of the loss angle | 200% or less of the initial specified value | | | |
| Test time | 2000 hours | | | | | | | | | | | |
| Leakage current | The initial specified value or less | | | | | | | | | | | |
| Percentage of capacitance change | Within ±20% of initial value | | | | | | | | | | | |
| Tangent of the loss angle | 200% or less of the initial specified value | | | | | | | | | | | |
| Shelf life (85°C) | Test time : 500 hours ; other items are the same as those for the endurance. Voltage application treatment : According to JIS C5101-1 | | | | | | | | | | | |
| Applicable standards | JIS C5101-1 1998, -18 1999 (IEC 60384-1 1992, -18 1993) | | | | | | | | | | | |

Outline Drawing

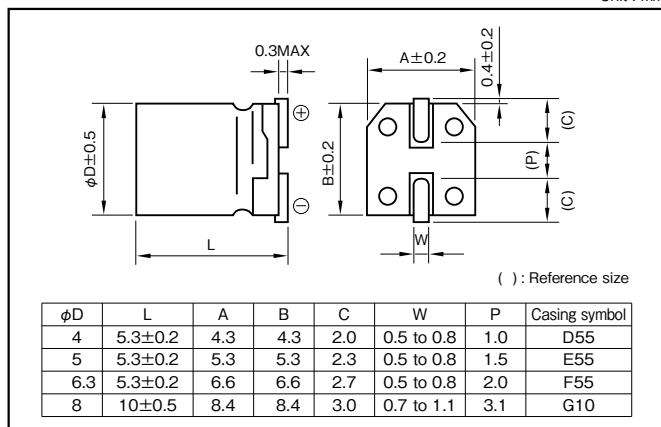

Coefficient of Frequency for Rated Ripple Current

| Rated voltage (V) \ Frequency (Hz) | 50 | 120 | 1k | 10k-100k |
|------------------------------------|------|-----|------|----------|
| 10 to 16 | 0.80 | 1 | 1.15 | 1.25 |
| 50 | 0.80 | 1 | 1.35 | 1.50 |

Part numbering system (example : 16V10µF)

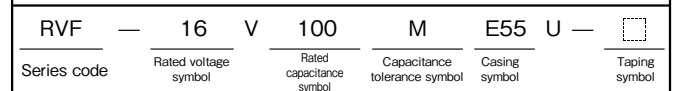

- Soldering conditions are described on page 13.
- Land pattern size are described on page 11.
- The taping specifications are described on page 14.

Standard Ratings

| Rated capacitance (µF) | 10 | | 16 | | 50 | |
|------------------------|----------------|------------------------------|----------------|------------------------------|----------------|------------------------------|
| | Case φD×L (mm) | Rated ripple current (mAmps) | Case φD×L (mm) | Rated ripple current (mAmps) | Case φD×L (mm) | Rated ripple current (mAmps) |
| 0.33 | — | — | — | — | 4×5.3 | 4 |
| 0.47 | — | — | — | — | 4×5.3 | 5 |
| 1 | — | — | — | — | 4×5.3 | 7 |
| 2.2 | — | — | — | — | 5×5.3 | 11 |
| 3.3 | — | — | — | — | 6.3×5.3 | 16 |
| 4.7 | — | — | 4×5.3 | 10 | 8×10 | 28 |
| 10 | 5×5.3 | 15 | 5×5.3 | 16 | 8×10 | 41 |
| 22 | 6.3×5.3 | 25 | 6.3×5.3 | 28 | — | — |
| 33 | 6.3×5.3 | 31 | 8×10 | 50 | — | — |
| 47 | 8×10 | 54 | 8×10 | 60 | — | — |
| 100 | 8×10 | 79 | 8×10 | 87 | — | — |

(Note) Rated ripple current : 85°C, 120Hz.

NOTE : Design, Specifications are subject to change without notice.
It is recommended that you shall obtain technical specifications from ELNA to ensure that the component is suitable for your use.

Chip Type, For Audio, High Grade Capacitors

GREEN CAP

SMD

105°C
2000hours

For Audio

- New developed Al-Foil and Electrolyte for Audio grade allow lower distortion.
- New range of bright and smooth sound is achieved in SMD area.
- Guarantees 2000 hours 105°C.

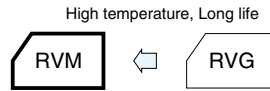

Marking color : Black print

Specifications

| Item | Performance | | | | | | | | | | | | | | | | | | | | |
|---|---|-------------------|------------|-----------------|-------------------------------------|----------------------------------|------------------------------|---------------------------|---|---------------|------|------|------|------|------|---------------|---|---|---|---|---|
| Category temperature range (°C) | -55 to +105 | | | | | | | | | | | | | | | | | | | | |
| Tolerance at rated capacitance (%) | ±20 (20°C, 120Hz) | | | | | | | | | | | | | | | | | | | | |
| Leakage current (µA) | Less than 0.01CV or 3 whichever is larger (after 2 minutes) C : Rated capacitance (µF), V: Rated voltage (V) (20°C) | | | | | | | | | | | | | | | | | | | | |
| Tangent of loss angle (tanδ) | <table border="1"> <thead> <tr> <th>Rated voltage (V)</th> <th>6.3</th> <th>10</th> <th>16</th> <th>25</th> <th>35</th> <th>50</th> </tr> </thead> <tbody> <tr> <td>tanδ (max.)</td> <td>0.28</td> <td>0.24</td> <td>0.20</td> <td>0.16</td> <td>0.13</td> <td>0.12</td> </tr> </tbody> </table> <p>(20°C, 120Hz)</p> | Rated voltage (V) | 6.3 | 10 | 16 | 25 | 35 | 50 | tanδ (max.) | 0.28 | 0.24 | 0.20 | 0.16 | 0.13 | 0.12 | | | | | | |
| Rated voltage (V) | 6.3 | 10 | 16 | 25 | 35 | 50 | | | | | | | | | | | | | | | |
| tanδ (max.) | 0.28 | 0.24 | 0.20 | 0.16 | 0.13 | 0.12 | | | | | | | | | | | | | | | |
| Characteristics at high and low temperature | <table border="1"> <thead> <tr> <th>Rated voltage (V)</th> <th>6.3</th> <th>10</th> <th>16</th> <th>25</th> <th>35</th> <th>50</th> </tr> </thead> <tbody> <tr> <td rowspan="2">Impedance ratio (max.)</td> <td>Z-25°C/Z+20°C</td> <td>4</td> <td>3</td> <td>2</td> <td>2</td> <td>2</td> </tr> <tr> <td>Z-55°C/Z+20°C</td> <td>8</td> <td>5</td> <td>4</td> <td>3</td> <td>3</td> </tr> </tbody> </table> <p>(120Hz)</p> | Rated voltage (V) | 6.3 | 10 | 16 | 25 | 35 | 50 | Impedance ratio (max.) | Z-25°C/Z+20°C | 4 | 3 | 2 | 2 | 2 | Z-55°C/Z+20°C | 8 | 5 | 4 | 3 | 3 |
| Rated voltage (V) | 6.3 | 10 | 16 | 25 | 35 | 50 | | | | | | | | | | | | | | | |
| Impedance ratio (max.) | Z-25°C/Z+20°C | 4 | 3 | 2 | 2 | 2 | | | | | | | | | | | | | | | |
| | Z-55°C/Z+20°C | 8 | 5 | 4 | 3 | 3 | | | | | | | | | | | | | | | |
| Endurance (105°C) | <table border="1"> <thead> <tr> <th>Test time</th> <td>2000 hours</td> </tr> </thead> <tbody> <tr> <td>Leakage current</td> <td>The initial specified value or less</td> </tr> <tr> <td>Percentage of capacitance change</td> <td>Within ±30% of initial value</td> </tr> <tr> <td>Tangent of the loss angle</td> <td>300% or less of the initial specified value</td> </tr> </tbody> </table> | Test time | 2000 hours | Leakage current | The initial specified value or less | Percentage of capacitance change | Within ±30% of initial value | Tangent of the loss angle | 300% or less of the initial specified value | | | | | | | | | | | | |
| Test time | 2000 hours | | | | | | | | | | | | | | | | | | | | |
| Leakage current | The initial specified value or less | | | | | | | | | | | | | | | | | | | | |
| Percentage of capacitance change | Within ±30% of initial value | | | | | | | | | | | | | | | | | | | | |
| Tangent of the loss angle | 300% or less of the initial specified value | | | | | | | | | | | | | | | | | | | | |
| Shelf life (105°C) | Test time : 1000 hours; other items are the same as those for the endurance. Voltage application treatment : According to JIS C5101-1 | | | | | | | | | | | | | | | | | | | | |
| Applicable standards | JIS C5101-1 1998, -18 1999 (IEC 60384-1 1992, -18 1993) | | | | | | | | | | | | | | | | | | | | |

Outline Drawing

Unit : mm

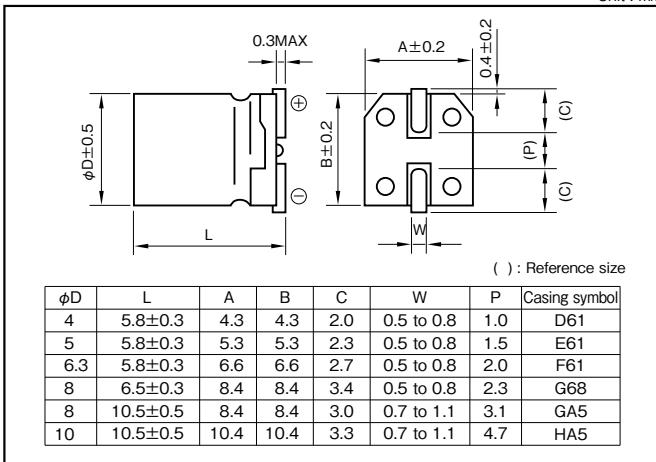

Coefficient of Frequency for Rated Ripple Current

| Rated voltage (V) | Frequency (Hz) | | | |
|-------------------|----------------|------|------|----------|
| | 50 | 120 | 1k | 10k·100k |
| 6.3 to 16 | 0.80 | 1 | 1.15 | 1.25 |
| 25 to 35 | 0.80 | 1 | 1.25 | 1.40 |
| 50 | 1 to 3.3µF | 0.50 | 1 | 1.35 |
| | 4.7µF or more | 0.70 | 1 | 1.35 |

Part numbering system (example : 6.3V220µF)

| | | | | | | | | | |
|-------------|---|----------------------|---|--------------------------|------------------------------|---------------|-----|---|---------------|
| RVM | — | 6 | V | 221 | M | G68 | P U | — | R2 |
| Series code | | Rated voltage symbol | | Rated capacitance symbol | Capacitance tolerance symbol | Casing symbol | | | Taping symbol |

- Soldering conditions are described on page 13.
- Land pattern size are described on page 11.
- The taping specifications are described on page 14.

Standard Ratings

| Rated capacitance (µF) | 6.3 | | 10 | | 16 | | 25 | | 35 | | 50 | |
|------------------------|----------------|------------------------------|----------------|------------------------------|----------------|------------------------------|----------------|------------------------------|----------------|------------------------------|----------------|------------------------------|
| | Case φD×L (mm) | Rated ripple current (mAmps) | Case φD×L (mm) | Rated ripple current (mAmps) | Case φD×L (mm) | Rated ripple current (mAmps) | Case φD×L (mm) | Rated ripple current (mAmps) | Case φD×L (mm) | Rated ripple current (mAmps) | Case φD×L (mm) | Rated ripple current (mAmps) |
| 1 | — | — | — | — | — | — | — | — | — | — | 4×5.8 | 7 |
| 2.2 | — | — | — | — | — | — | — | — | — | — | 4×5.8 | 10 |
| 3.3 | — | — | — | — | — | — | — | — | — | — | 4×5.8 | 12 |
| 4.7 | — | — | — | — | 4×5.8 | 11 | 4×5.8 | 13 | 4×5.8 | 14 | 5×5.8 | 17 |
| 10 | — | — | 4×5.8 | 15 | 4×5.8 | 17 | 5×5.8 | 21 | 5×5.8 | 24 | 6.3×5.8 | 29 |
| 22 | 4×5.8 | 21 | 5×5.8 | 26 | 5×5.8 | 28 | 6.3×5.8 | 37 | 6.3×5.8 | 41 | 8×6.5 | 52 |
| 33 | 5×5.8 | 29 | 5×5.8 | 32 | 6.3×5.8 | 41 | 6.3×5.8 | 45 | 8×6.5 | 62 | 8×10.5 | 75 |
| 47 | 5×5.8 | 35 | 6.3×5.8 | 44 | 6.3×5.8 | 48 | 8×6.5 | 66 | 8×10.5 | 86 | 8×10.5 | 90 |
| 100 | 6.3×5.8 | 60 | 8×6.5 | 79 | 8×6.5 | 86 | 8×10.5 | 113 | 10×10.5 | 145 | 10×10.5 | 151 |
| | | | | | 8×10.5 | 101 | | | | | | |
| 220 | 8×10.5 | 127 | 8×10.5 | 137 | 8×10.5 | 150 | 10×10.5 | 194 | 10×10.5 | 216 | — | — |
| | | | | | 10×10.5 | 174 | | | | | | |
| 330 | 8×10.5 | 156 | 10×10.5 | 194 | 10×10.5 | 213 | — | — | — | — | — | — |
| 470 | 10×10.5 | 215 | 10×10.5 | 232 | 10×10.5 | 254 | — | — | — | — | — | — |

(Note) Rated ripple current : 105°C, 120Hz.

Chip Type Audio Use Capacitors **GREEN CAP** **SMD** **105°C 1000hours** **For Audio**

- Audio grade surface mount product with completely new components using synthetic mica paper for the separator.
- Both quality sense and sound field that could not be realized by the surface mount products are reproducible.

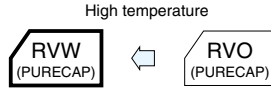

Marking color : Black print (except height : 10mm)
White print on a brown sleeve (φ8×10L, φ10×10L)

Specifications

| Item | Performance | | | | | | |
|---|--|---|------|------|------|------|------|
| Category temperature range (°C) | -55 to +105 | | | | | | |
| Tolerance at rated capacitance (%) | ±20 (20°C, 120Hz) | | | | | | |
| Leakage current (μA) | Less than 0.01CV or 3 whichever is larger (after 2 minutes) C : Rated capacitance (μF) ; V : Rated voltage (V) (20°C) | | | | | | |
| Tangent of loss angle (tanδ) | Rated voltage (V) | 6.3 | 10 | 16 | 25 | 35 | 50 |
| | tanδ (max.) | 0.30 | 0.26 | 0.22 | 0.16 | 0.13 | 0.12 |
| Characteristics at high and low temperature | Impedance ratio (max.) | Z-25°C/Z+20°C | 4 | 3 | 2 | 2 | 2 |
| | | Z-40°C/Z+20°C | 8 | 5 | 4 | 3 | 3 |
| Endurance (105°C) (Applied ripple current) | Test time | 1000 hours | | | | | |
| | Leakage current | The initial specified value or less | | | | | |
| | Percentage of capacitance change | Within ±20% of initial value | | | | | |
| | Tangent of the loss angle | 200% or less of the initial specified value | | | | | |
| Shelf life (105°C) | Test time : 1000 hours ; other items are the same as those for the endurance. Voltage application treatment : According to JIS C5101 -1 | | | | | | |
| Applicable standards | JIS C5101-1 1998, -18 1999 (IEC 60384-1 1992, -18 1993) | | | | | | |

Outline Drawing

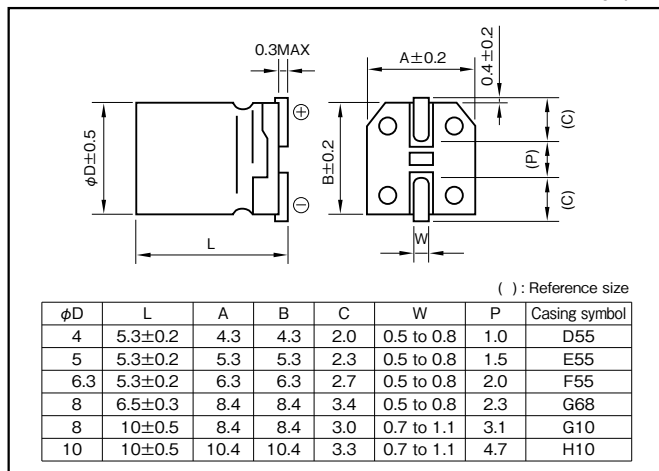

Coefficient of Frequency for Rated Ripple Current

| Frequency (Hz) | 50 | 120 | 1k | 10k-100k |
|-------------------|------|-----|------|----------|
| Rated voltage (V) | | | | |
| 6.3 to 16 | 0.80 | 1 | 1.15 | 1.25 |
| 25 to 35 | 0.80 | 1 | 1.25 | 1.40 |
| 50 | 0.80 | 1 | 1.35 | 1.50 |

Part numbering system (example : 16V471 M H10 P2 U)

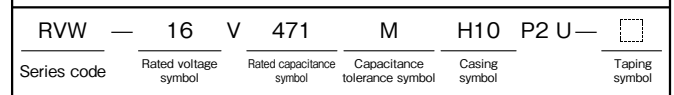

- Soldering conditions are described on page 13.
- Land pattern size are described on page 11.
- The taping specifications are described on page 14.

Standard Ratings

| Rated capacitance (μF) | 6.3 | | 10 | | 16 | | 25 | | 35 | | 50 | |
|------------------------|---------|----------------------|---------|----------------------|---------|----------------------|---------|----------------------|---------|----------------------|---------|----------------------|
| | Case | Rated ripple current | Case | Rated ripple current | Case | Rated ripple current | Case | Rated ripple current | Case | Rated ripple current | Case | Rated ripple current |
| 0.33 | — | — | — | — | — | — | — | — | — | — | 4×5.3 | 4 |
| 0.47 | — | — | — | — | — | — | — | — | — | — | 4×5.3 | 5 |
| 1 | — | — | — | — | — | — | — | — | — | — | 4×5.3 | 7 |
| 2.2 | — | — | — | — | — | — | — | — | — | — | 4×5.3 | 10 |
| 3.3 | — | — | — | — | — | — | — | — | — | — | 4×5.3 | 12 |
| 4.7 | — | — | — | — | — | — | 4×5.3 | 12 | 4×5.3 | 14 | 5×5.3 | 17 |
| 10 | — | — | 4×5.3 | 15 | 4×5.3 | 16 | 5×5.3 | 21 | 5×5.3 | 23 | 6.3×5.3 | 26 |
| 22 | 4×5.3 | 21 | 5×5.3 | 25 | 5×5.3 | 28 | 6.3×5.3 | 36 | 6.3×5.3 | 50 | 8×6.5 | 110 |
| 33 | 5×5.3 | 30 | 5×5.3 | 31 | 6.3×5.3 | 40 | 6.3×5.3 | 44 | 8×6.5 | 110 | 8×10 | 178 |
| 47 | 5×5.3 | 36 | 6.3×5.3 | 43 | 6.3×5.3 | 47 | 8×6.5 | 110 | 8×10 | 178 | 8×10 | 178 |
| 100 | 6.3×5.3 | 61 | 8×6.5 | 110 | 8×10 | 178 | 8×10 | 178 | 10×10 | 324 | 10×10 | 324 |
| 220 | 8×10 | 178 | 8×10 | 178 | 10×10 | 324 | 10×10 | 324 | 10×10 | 324 | — | — |
| 330 | 8×10 | 178 | 10×10 | 324 | 10×10 | 324 | — | — | — | — | — | — |
| 470 | 10×10 | 324 | 10×10 | 324 | 10×10 | 324 | — | — | — | — | — | — |

(Note) Rated ripple current : 105°C, 120Hz.

Chip Type Audio Use Capacitors

GREEN CAP SMD For Audio

- New developed Al-Foil and Electrolyte for Audio grade allow lower distortion.
- New range of bright and smooth sound is achieved in SMD area.



Marking color : Black print

Specifications

| Item | Performance | | | | | |
|--|---|---|------|------|------|------|
| Category temperature range (°C) | -40 to +85 | | | | | |
| Tolerance at rated capacitance (%) | ±20 (20°C, 120Hz) | | | | | |
| Leakage current (µA) | Less than 0.01CV or 3 whichever is larger (after 2 minutes) C : Rated capacitance (µF) ; V : Rated voltage (V) (20°C) | | | | | |
| Tangent of loss angle (tanδ) | Rated voltage (V) | 6.3 | 10 | 16 | 25 | 35 |
| | tanδ (max.) | 0.28 | 0.24 | 0.20 | 0.16 | 0.14 |
| Characteristics at high and low temperature | Impedance ratio (max.) | Z-25°C/Z+20°C | 4 | 3 | 2 | 2 |
| | | Z-40°C/Z+20°C | 8 | 5 | 4 | 3 |
| Endurance (85°C) (Applied ripple current) | Test time | 2000 hours | | | | |
| | Leakage current | The initial specified value or less | | | | |
| | Percentage of capacitance change | Within ±20% of initial value | | | | |
| | Tangent of the loss angle | 200% or less of the initial specified value | | | | |
| Shelf life (85°C) | Test time : 500 hours ; other items are the same as those for the endurance. Voltage application treatment : According to JIS C5101 -1 | | | | | |
| Applicable standards | JIS C5101-1 1998, -18 1999 (IEC 60384-1 1992, -18 1993) | | | | | |

Outline Drawing

Unit : mm

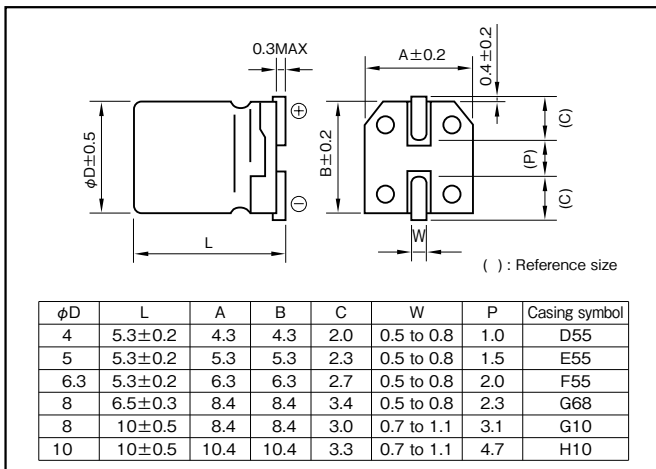

Coefficient of Frequency for Rated Ripple Current

| Frequency (Hz) | 50 | 120 | 1k | 10k · 100k |
|-------------------|------|-----|------|------------|
| Rated voltage (V) | | | | |
| 6.3 to 16 | 0.80 | 1 | 1.15 | 1.25 |
| 25 to 35 | 0.80 | 1 | 1.25 | 1.40 |

Part numbering system (example : 16V47 µF)

| | | | | | | | | |
|-------------|---|----------------------|---|--------------------------|------------------------------|---------------|---|---------------|
| RVG | — | 16 | V | 470 | M | F55 | U | □ |
| Series code | | Rated voltage symbol | | Rated capacitance symbol | Capacitance tolerance symbol | Casing symbol | | Taping symbol |

- Soldering conditions are described on page 13.
- Land pattern size are described on page 11.
- The taping specifications are described on page 14.

Standard Ratings

| Rated voltage (V) | 6.3 | | 10 | | 16 | | 25 | | 35 | |
|------------------------|-----------|----------------------|-----------|----------------------|-----------|----------------------|-----------|----------------------|-----------|----------------------|
| | Case | Rated ripple current | Case | Rated ripple current | Case | Rated ripple current | Case | Rated ripple current | Case | Rated ripple current |
| Rated capacitance (µF) | φD×L (mm) | (mArms) | φD×L (mm) | (mArms) | φD×L (mm) | (mArms) | φD×L (mm) | (mArms) | φD×L (mm) | (mArms) |
| 3.3 | — | — | — | — | — | — | — | — | 4×5.3 | 11 |
| 4.7 | — | — | — | — | 4×5.3 | 11 | 4×5.3 | 12 | 4×5.3 | 13 |
| 10 | — | — | — | — | 5×5.3 | 19 | 5×5.3 | 21 | 5×5.3 | 22 |
| 22 | 4×5.3 | 20 | — | — | 5×5.3 | 28 | 6.3×5.3 | 36 | 6.3×5.3 | 39 |
| 33 | 5×5.3 | 29 | 5×5.3 | 31 | 6.3×5.3 | 40 | 6.3×5.3 | 44 | 8×6.5 | 60 |
| 47 | 5×5.3 | 34 | 6.3×5.3 | 43 | 6.3×5.3 | 47 | 8×6.5 | 66 | 8×10 | 82 |
| 100 | 6.3×5.3 | 58 | 8×6.5 | 79 | 8×6.5 | 87 | 8×10 | 112 | 10×10 | 139 |
| 220 | 8×6.5 | 107 | 8×10 | 136 | 8×10 | 149 | 10×10 | 192 | — | — |
| 330 | 8×10 | 153 | 8×10 | 166 | 10×10 | 221 | — | — | — | — |
| 470 | 8×10 | 183 | 10×10 | 229 | — | — | — | — | — | — |

(Note) Rated ripple current : 85°C, 120Hz

SILMIC series Silk fiber using audio purpose capacitor

- ELNA developed new raw material for the separate paper which use a silk fibers. Therefore, this capacitor can give you high grade sound for your audio design.
- Due to the silk fiber's pliability, the capacitor makes a dream of the high quality sound.

For examples ;

- To relieve the music's vibration energy.
- To decrease the peak feeling sound at high compass and rough quality sound at middle compass.
- To increase massive sound at low compass.
- For bipolar capacitors, consult with us.

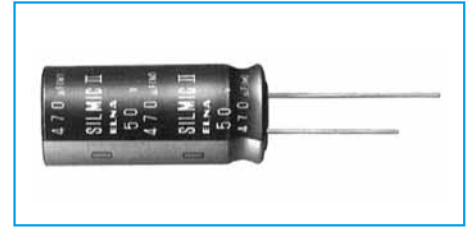

Marking color : White print on a brown sleeve

Miniature High Grade Capacitors for Audio(SILMIC II)

GREEN CAP For Audio

- All lead wires oxygen-free copper for extremely low distortion. (Third high frequency distortion 10kHz,0.1A,-120dB or less)
- "SILMIC II" mark on sleeve.

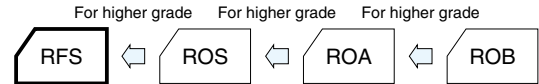

Specifications

| Item | Performance | | | | | | | | |
|---|---|---|------|------|------|------|------|------|------|
| Category temperature range (°C) | -40 to +85 | | | | | | | | |
| Tolerance at rated capacitance (%) | ±20 (20°C,120Hz) | | | | | | | | |
| Leakage current (µA) | Less than 0.01CV or 3 whichever is larger (after 5 minutes) C : Rated capacitance (µF) ; V : Rated voltage (V) (20°C) | | | | | | | | |
| Tangent of loss angle (tanδ) | Rated voltage (V) | 6.3 | 10 | 16 | 25 | 35 | 50 | 63 | 100 |
| | tanδ (max.) | 0.20 | 0.17 | 0.13 | 0.10 | 0.10 | 0.08 | 0.08 | 0.08 |
| 0.02 is added to every 1000µF increase over 1000µF (20°C,120Hz) | | | | | | | | | |
| Endurance (85°C) (Applied ripple current) | Test time | 1000 hours (with the polarity inverted every 250 hours) | | | | | | | |
| | Leakage current | The initial specified value or less | | | | | | | |
| | Percentage of capacitance change | Within ±20% of initial value | | | | | | | |
| | Tangent of the loss angle | 150% or less of the initial specified value | | | | | | | |
| Shelf life (85°C) | Test time : 1000 hours. Other have same as endurance. Voltage application treatment : According to JIS C5101 -1 | | | | | | | | |
| Applicable standards | JIS C5101-1, -4 1998 (IEC 60384-1 1992, -4 1985) | | | | | | | | |

Outline Drawing

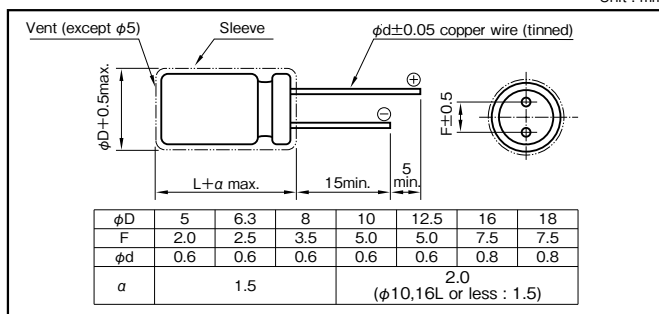

Coefficient of Frequency for Rated Ripple Current

| Rated voltage (V) | Frequency (Hz) CV (µF×VV) | CV (µF×VV) | | | | |
|-------------------|------------------------------|------------|-----|-----|-----|------|
| | | 50 · 60 | 120 | 1k | 10k | 100k |
| 6.3 to 16 | All CV value | 0.8 | 1 | 1.1 | 1.2 | 1.2 |
| | ≤1000 | 0.8 | 1 | 1.5 | 1.7 | 1.7 |
| 25 to 35 | 1000< | 0.8 | 1 | 1.2 | 1.3 | 1.3 |
| | ≤1000 | 0.8 | 1 | 1.6 | 1.9 | 1.9 |
| 50 to 100 | 1000< | 0.8 | 1 | 1.2 | 1.3 | 1.3 |

Part numbering system (example : 25V100µF)



Case symbol

| Case φDXL (mm) | Casing Symbol | Case φDXL (mm) | Casing Symbol | Case φDXL (mm) | Casing Symbol | Case φDXL (mm) | Casing Symbol |
|----------------|---------------|----------------|---------------|----------------|---------------|----------------|---------------|
| 5×11 | E3 | 10×12.5 | H3 | 12.5×20 | I5 | 16×31.5 | J7 |
| 6.3×11 | F3 | 10×16 | H4 | 12.5×25 | I6 | 16×35.5 | J8 |
| 8×11.5 | G3 | 10×20 | H5 | 16×25 | J6 | 18×35.5 | K8 |
| | | | | 18×40 | J9 | | |

Standard Ratings

| Rated capacitance (µF) | 6.3 | | 10 | | 16 | | 25 | | 35 | | 50 | | 63 | | 100 | |
|------------------------|----------------|---------------------------|----------------|---------------------------|----------------|---------------------------|----------------|---------------------------|----------------|---------------------------|----------------|---------------------------|----------------|---------------------------|----------------|---------------------------|
| | Case φDXL (mm) | Rated ripple current (mA) | Case φDXL (mm) | Rated ripple current (mA) | Case φDXL (mm) | Rated ripple current (mA) | Case φDXL (mm) | Rated ripple current (mA) | Case φDXL (mm) | Rated ripple current (mA) | Case φDXL (mm) | Rated ripple current (mA) | Case φDXL (mm) | Rated ripple current (mA) | Case φDXL (mm) | Rated ripple current (mA) |
| 2.2 | — | — | — | — | — | — | — | — | — | — | 5×11 | 20 | 5×11 | 22 | 5×11 | 25 |
| 3.3 | — | — | — | — | — | — | — | — | — | — | 6.3×11 | 23 | 5×11 | 30 | 6.3×11 | 30 |
| | — | — | — | — | — | — | — | — | — | — | 6.3×11 | 30 | 6.3×11 | 40 | 8×11.5 | 40 |
| 4.7 | — | — | — | — | — | — | 5×11 | 25 | 5×11 | 30 | 5×11 | 35 | 5×11 | 35 | 10×12.5 | 60 |
| | — | — | — | — | — | — | 5×11 | 35 | 5×11 | 35 | 6.3×11 | 40 | 6.3×11 | 40 | 10×16 | 95 |
| 10 | — | — | — | — | 5×11 | 35 | 6.3×11 | 60 | 6.3×11 | 55 | 8×11.5 | 75 | 8×11.5 | 75 | 10×16 | 95 |
| | — | — | — | — | 5×11 | 55 | 6.3×11 | 70 | 6.3×11 | 80 | 10×12.5 | 130 | 10×16 | 140 | 10×20 | 155 |
| 22 | — | — | 5×11 | 50 | 6.3×11 | 70 | 6.3×11 | 80 | 8×11.5 | 95 | 10×12.5 | 130 | 10×16 | 140 | 10×20 | 155 |
| | — | — | 5×11 | 65 | 6.3×11 | 70 | 6.3×11 | 90 | 8×11.5 | 120 | 10×12.5 | 140 | 10×16 | 175 | 10×20 | 190 |
| 33 | 5×11 | 55 | 5×11 | 75 | 6.3×11 | 85 | 8×11.5 | 125 | 8×11.5 | 140 | 10×12.5 | 170 | 10×16 | 210 | 10×20 | 225 |
| | 6.3×11 | 80 | 6.3×11 | 85 | 8×11.5 | 125 | 8×11.5 | 140 | 10×12.5 | 170 | 10×16 | 210 | 10×20 | 225 | 12.5×25 | 285 |
| 100 | 8×11.5 | 135 | 8×11.5 | 145 | 10×12.5 | 215 | 10×16 | 270 | 10×20 | 295 | 12.5×20 | 380 | 12.5×25 | 415 | 16×25 | 485 |
| 220 | 10×12.5 | 240 | 10×16 | 260 | 10×20 | 385 | 12.5×20 | 505 | 12.5×25 | 550 | 16×25 | 720 | 16×31.5 | 785 | 18×40 | 930 |
| 330 | 10×16 | 290 | 10×20 | 350 | 12.5×20 | 545 | 12.5×25 | 675 | 16×25 | 785 | 16×31.5 | 965 | 16×35.5 | 1010 | — | — |
| 470 | 10×20 | 390 | 12.5×20 | 455 | 12.5×25 | 710 | 16×25 | 940 | 16×31.5 | 1030 | 16×35.5 | 1210 | 18×35.5 | 1295 | — | — |
| 1000 | 12.5×20 | 710 | 16×25 | 835 | 16×31.5 | 1315 | 16×35.5 | 1575 | 18×35.5 | 1690 | 18×40 | 1985 | — | — | — | — |
| 2200 | — | — | 16×35.5 | 1500 | 18×40 | 2150 | — | — | — | — | — | — | — | — | — | — |
| 3300 | — | — | 18×40 | 1980 | — | — | — | — | — | — | — | — | — | — | — | — |

(Note) Rated ripple current : 85°C, 120Hz

NOTE : Design, Specifications are subject to change without notice. It is recommended that you shall obtain technical specifications from ELNA to ensure that the component is suitable for your use.

SILMIC series Silk fiber using audio purpose capacitor

High Grade Capacitors for Audio(SILMIC)

GREEN CAP For Audio

- All lead wires oxygen-free copper for extremely low distortion. (Third high frequency distortion 10kHz,0.1A,-120dB or less)
- "SILMIC" mark on sleeve.



Marking color : White print on a brown sleeve

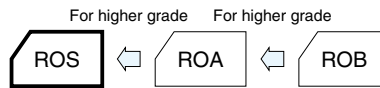

Specifications

| Item | Performance | | | | | | |
|---|---|---|------|------|------|------|------|
| Category temperature range (°C) | -40 to +85 | | | | | | |
| Tolerance at rated capacitance (%) | ±20 (20°C,120Hz) | | | | | | |
| Leakage current (µA) | Less than 0.01CV or 3 whichever is larger (after 5 minutes) C : Rated capacitance (µF) ; V : Rated voltage (V) (20°C) | | | | | | |
| Tangent of loss angle (tanδ) | Rated voltage (V) | 16 | 25 | 35 | 50 | 63 | 100 |
| | tanδ (max.) | 0.13 | 0.10 | 0.10 | 0.08 | 0.08 | 0.08 |
| 0.02 is added to every 1000µF increase over 1000µF (20°C,120Hz) | | | | | | | |
| Endurance (85°C) (Applied ripple current) | Test time | 1000 hours | | | | | |
| | Leakage current | The initial specified value or less | | | | | |
| | Percentage of capacitance change | Within ±20% of initial value | | | | | |
| | Tangent of the loss angle | 150% or less of the initial specified value | | | | | |
| Shelf life (85°C) | Test time : 1000 hours. Other have same as endurance. Voltage application treatment : According to JIS C5101 -1 | | | | | | |
| Applicable standards | JIS C5101-1, -4 1998 (IEC 60384-1 1992, -4 1985) | | | | | | |

Outline Drawing

Unit : mm

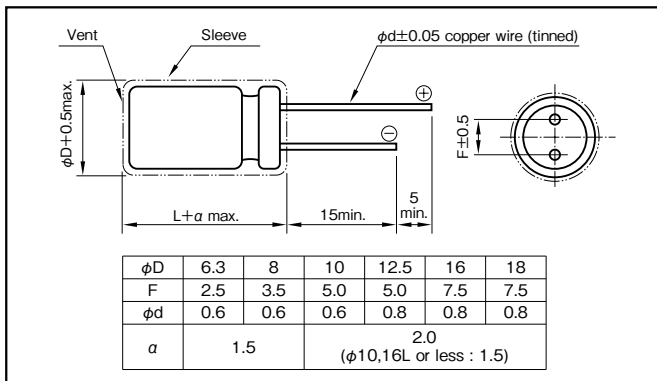

Coefficient of Frequency for Rated Ripple Current

| Rated voltage (V) | Frequency (Hz) CV(µF×WV) | 50 · 60 | 120 | 1k | 10k | 100k |
|-------------------|-----------------------------|---------|--------------|-----|-----|------|
| | | 16 | All CV value | 0.8 | 1 | 1.1 |
| 25 to 35 | ≤1000 | 0.8 | 1 | 1.5 | 1.7 | 1.7 |
| | 1000< | 0.8 | 1 | 1.2 | 1.3 | 1.3 |
| 50 to 100 | ≤1000 | 0.8 | 1 | 1.6 | 1.9 | 1.9 |
| | 1000< | 0.8 | 1 | 1.2 | 1.3 | 1.3 |

Part numbering system (example : 25V100µF)

| | | | | | | | | |
|-------------|----------------------|---|--------------------------|------------------------------|---------------|----|---|-------------------------|
| ROS | 25 | V | 101 | M | H4 | #5 | — | |
| Series code | Rated voltage symbol | | Rated capacitance symbol | Capacitance tolerance symbol | Casing symbol | | | Taping (Forming) symbol |

Case symbol

| Case φD×L (mm) | Casing Symbol | Case φD×L (mm) | Casing Symbol | Case φD×L (mm) | Casing Symbol | Case φD×L (mm) | Casing Symbol |
|----------------|---------------|----------------|---------------|----------------|---------------|----------------|---------------|
| 6.3×11 | F3 | 10×16 | H4 | 12.5×25 | I6 | 16×35.5 | J8 |
| 8×11.5 | G3 | 10×20 | H5 | 16×25 | J6 | 18×35.5 | K8 |
| 10×12.5 | H3 | 12.5×20 | I5 | 16×31.5 | J7 | 18×40 | K9 |

Standard Ratings

| Rated voltage (V) / Item | 16 | | 25 | | 35 | | 50 | | 63 | | 100 | |
|--------------------------|----------------|------------------------------|----------------|------------------------------|----------------|------------------------------|----------------|------------------------------|----------------|------------------------------|----------------|------------------------------|
| | Case φD×L (mm) | Rated ripple current (mArms) | Case φD×L (mm) | Rated ripple current (mArms) | Case φD×L (mm) | Rated ripple current (mArms) | Case φD×L (mm) | Rated ripple current (mArms) | Case φD×L (mm) | Rated ripple current (mArms) | Case φD×L (mm) | Rated ripple current (mArms) |
| 2.2 | — | — | — | — | — | — | — | — | — | — | 6.3×11 | 25 |
| 3.3 | — | — | — | — | — | — | — | — | — | — | 8×11.5 | 35 |
| 4.7 | — | — | — | — | — | — | 6.3×11 | 40 | 6.3×11 | 40 | 10×12.5 | 60 |
| 10 | — | — | — | — | 6.3×11 | 55 | 8×11.5 | 75 | 8×11.5 | 75 | 10×16 | 95 |
| 22 | 6.3×11 | 70 | 6.3×11 | 80 | 8×11.5 | 95 | 10×12.5 | 130 | 10×16 | 140 | 10×20 | 155 |
| 33 | 6.3×11 | 90 | 8×11.5 | 120 | 10×12.5 | 140 | 10×16 | 175 | 10×20 | 190 | 12.5×20 | 220 |
| 47 | 8×11.5 | 125 | 8×11.5 | 140 | 10×12.5 | 170 | 10×16 | 210 | 10×20 | 225 | 12.5×25 | 285 |
| 100 | 10×12.5 | 215 | 10×16 | 270 | 10×20 | 295 | 12.5×20 | 380 | 12.5×25 | 415 | 16×25 | 485 |
| 220 | 10×20 | 385 | 12.5×20 | 505 | 12.5×25 | 550 | 16×25 | 720 | 16×31.5 | 785 | 18×40 | 930 |
| 330 | 12.5×20 | 545 | 12.5×25 | 675 | 16×25 | 785 | 16×31.5 | 965 | 16×35.5 | 1010 | — | — |
| 470 | 12.5×25 | 710 | 16×25 | 940 | 16×31.5 | 1030 | 16×35.5 | 1210 | 18×35.5 | 1295 | — | — |
| 1000 | 16×31.5 | 1315 | 16×35.5 | 1575 | 18×35.5 | 1690 | 18×40 | 1985 | — | — | — | — |
| 2200 | 18×40 | 2150 | — | — | — | — | — | — | — | — | — | — |

(Note) Rated ripple current : 85°C, 120Hz.

NOTE : Design, Specifications are subject to change without notice. It is recommended that you shall obtain technical specifications from ELNA to ensure that the component is suitable for your use.

Miniature Standard Capacitors for Audio

GREEN CAP For Audio

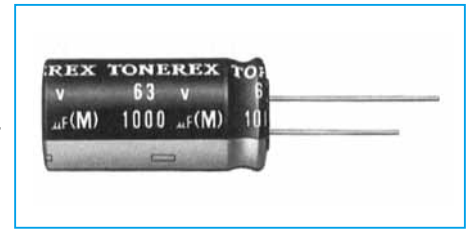

Marking color : Gold print on a black sleeve

TONEREX

- Adopting the newly developed formation method and composite electrolytic paper for audio application has reduced distortion, achieving high-quality sound.
- All lead wires are oxygen-free copper wires to reduce distortion.

Specifications

| Item | Performance | | | | | | | | | |
|---|---|---|------|------|------|------|------|------|------|--|
| Category temperature range (°C) | -40 to +85 | | | | | | | | | |
| Tolerance at rated capacitance (%) | ±20 (20°C,120Hz) | | | | | | | | | |
| Leakage current (μA) | Less than 0.01CV or 4 whichever is larger (after 5 minutes) C : Rated capacitance (μF) ; V : Rated voltage (V) (20°C) | | | | | | | | | |
| Tangent of loss angle (tanδ) | Rated voltage (V) | 6.3 | 10 | 16 | 25 | 35 | 50 | 63 | 100 | |
| | tanδ (max.) | 0.24 | 0.20 | 0.16 | 0.14 | 0.12 | 0.10 | 0.09 | 0.08 | |
| 0.02 is added to every 1000μF increase over 1000μF (20°C,120Hz) | | | | | | | | | | |
| Endurance (85°C) (Applied ripple current) | Test time | 1000 hours | | | | | | | | |
| | Leakage current | The initial specified value or less | | | | | | | | |
| | Percentage of capacitance change | Within ±20% of initial value | | | | | | | | |
| | Tangent of the loss angle | 150% or less of the initial specified value | | | | | | | | |
| Shelf life (85°C) | Test time : 1000 hours. Other have same as endurance. Voltage application treatment : According to JIS C5101 -1 | | | | | | | | | |
| Applicable standards | JIS C5101-1, -4 1998 (IEC 60384-1 1992, -4 1985) | | | | | | | | | |

Outline Drawing

Unit : mm

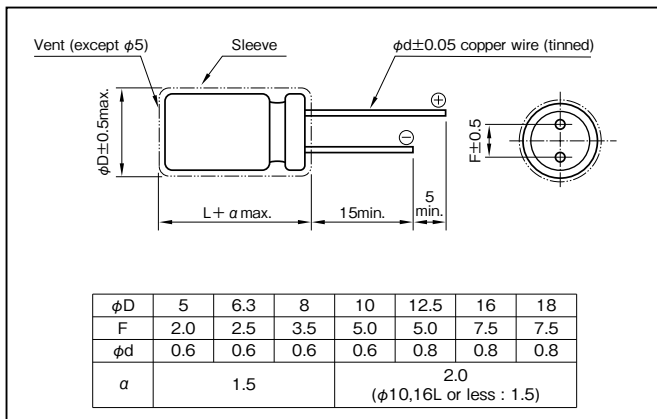

Coefficient of Frequency for Rated Ripple Current

| Rated voltage (V) | Frequency (Hz) CV (μF×VV) | 50·60 | 120 | 1k | 10k | 100k |
|-------------------|------------------------------|-----------|--------------|-----|-----|------|
| | | 6.3 to 16 | All CV value | 0.8 | 1 | 1.1 |
| 25 to 35 | ≤1000 | 0.8 | 1 | 1.5 | 1.7 | 1.7 |
| | 1000< | 0.8 | 1 | 1.2 | 1.3 | 1.3 |
| 50 to 100 | ≤1000 | 0.8 | 1 | 1.6 | 1.9 | 1.9 |
| | 1000< | 0.8 | 1 | 1.2 | 1.3 | 1.3 |

Part numbering system (example : 25V100μF)

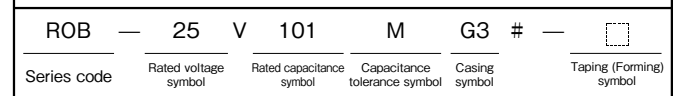

Case symbol

| Case Symbol | Casing Symbol | Case φD×L (mm) | Casing Symbol | Case φD×L (mm) | Casing Symbol | Case φD×L (mm) | Casing Symbol |
|-------------|---------------|----------------|---------------|----------------|---------------|----------------|---------------|
| 5×11 | E3 | 10×12.5 | H3 | 12.5×20 | I5 | 16×31.5 | J7 |
| 6.3×11 | F3 | 10×16 | H4 | 12.5×25 | I6 | 16×35.5 | J8 |
| 8×11.5 | G3 | 10×20 | H5 | 16×25 | J6 | 18×35.5 | K8 |
| | | | | | | 18×40 | K9 |

Standard Ratings

| Rated capacitance (μF) | Item | 6.3 | | 10 | | 16 | | 25 | | 35 | | 50 | | 63 | | 100 | |
|------------------------|------|----------------|------------------------------|----------------|------------------------------|----------------|------------------------------|----------------|------------------------------|----------------|------------------------------|----------------|------------------------------|----------------|------------------------------|----------------|------------------------------|
| | | Case φD×L (mm) | Rated ripple current (mArms) | Case φD×L (mm) | Rated ripple current (mArms) | Case φD×L (mm) | Rated ripple current (mArms) | Case φD×L (mm) | Rated ripple current (mArms) | Case φD×L (mm) | Rated ripple current (mArms) | Case φD×L (mm) | Rated ripple current (mArms) | Case φD×L (mm) | Rated ripple current (mArms) | Case φD×L (mm) | Rated ripple current (mArms) |
| 1 | | — | — | — | — | — | — | — | — | — | — | 5×11 | 10 | — | — | 5×11 | 15 |
| 2.2 | | — | — | — | — | — | — | — | — | — | — | 5×11 | 20 | — | — | 5×11 | 25 |
| 3.3 | | — | — | — | — | — | — | — | — | — | — | 5×11 | 25 | — | — | 5×11 | 30 |
| 4.7 | | — | — | — | — | — | — | 5×11 | 25 | — | — | 5×11 | 35 | 5×11 | 35 | 6.3×11 | 40 |
| 10 | | — | — | — | — | 5×11 | 35 | 5×11 | 40 | 5×11 | 45 | 5×11 | 50 | 6.3×11 | 60 | 8×11.5 | 70 |
| 22 | | — | — | 5×11 | 50 | 5×11 | 60 | 5×11 | 60 | 6.3×11 | 75 | 6.3×11 | 80 | 8×11.5 | 100 | 10×12.5 | 120 |
| 33 | | 5×11 | 55 | 5×11 | 65 | 5×11 | 70 | 6.3×11 | 80 | 6.3×11 | 90 | 8×11.5 | 110 | 8×11.5 | 115 | 10×16 | 160 |
| 47 | | 5×11 | 65 | 5×11 | 75 | 6.3×11 | 95 | 6.3×11 | 100 | 8×11.5 | 120 | 8×11.5 | 130 | 10×12.5 | 165 | 10×20 | 210 |
| 100 | | 6.3×11 | 110 | 6.3×11 | 120 | 8×11.5 | 150 | 8×11.5 | 165 | 10×12.5 | 210 | 10×16 | 250 | 10×20 | 285 | 12.5×20 | 340 |
| 220 | | 8×11.5 | 185 | 8×11.5 | 200 | 10×12.5 | 265 | 10×16 | 310 | 10×20 | 365 | 12.5×20 | 440 | 12.5×20 | 470 | 16×25 | 620 |
| 330 | | 10×12.5 | 265 | 10×12.5 | 290 | 10×16 | 350 | 10×20 | 410 | 12.5×20 | 500 | 12.5×20 | 540 | 12.5×25 | 620 | 16×31.5 | 820 |
| 470 | | 10×12.5 | 315 | 10×16 | 380 | 10×20 | 460 | 12.5×20 | 550 | 12.5×25 | 640 | 16×25 | 800 | 16×25 | 840 | 18×35.5 | 1000 |
| 1000 | | 10×20 | 550 | 12.5×20 | 670 | 12.5×25 | 810 | 16×25 | 1000 | 16×25 | 1050 | 16×31.5 | 1200 | 18×35.5 | 1500 | — | — |
| 2200 | | 12.5×25 | 980 | 16×25 | 1200 | 16×25 | 1350 | 16×35.5 | 1650 | 18×35.5 | 1900 | — | — | — | — | — | — |
| 3300 | | 16×25 | 1300 | 16×31.5 | 1600 | 16×35.5 | 1800 | 18×40 | 2100 | — | — | — | — | — | — | — | — |
| 4700 | | 16×31.5 | 1700 | 16×35.5 | 1900 | 18×35.5 | 2400 | — | — | — | — | — | — | — | — | — | — |
| 6800 | | 16×35.5 | 2100 | 18×40 | 2600 | — | — | — | — | — | — | — | — | — | — | — | — |
| 10000 | | 18×40 | 2800 | — | — | — | — | — | — | — | — | — | — | — | — | — | — |

(Note) Rated ripple current : 85°C, 120Hz

NOTE : Design, Specifications are subject to change without notice. It is recommended that you shall obtain technical specifications from ELNA to ensure that the component is suitable for your use.

Miniature Capacitors for Audio (PURECAP)

GREEN CAP For Audio

- A standard capacitor utilizing a newly developed material for a high grade of audio reproduction.
- Copper clad steel wire is used for leads.
- New type miniaturized capacitor for audio, using synthetic mica paper for the separator.

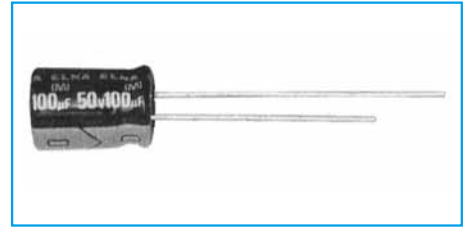

Marking color : Gold print on a black sleeve

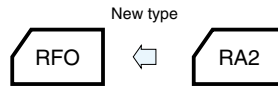

Specifications

| Item | Performance | | | | | | | | |
|--|---|---|------|------|------|------|------|------|------|
| Category temperature range (°C) | -40 to +85 | | | | | | | | |
| Tolerance at rated capacitance (%) | ±20 (20°C, 120Hz) | | | | | | | | |
| Leakage current (µA) | Less than 0.01CV or 3 whichever is larger (after 2 minutes) C : Rated capacitance (µF) ; V : Rated voltage (V) (20°C) | | | | | | | | |
| Tangent of loss angle (tanδ) | Rated voltage (V) | 6.3 | 10 | 16 | 25 | 35 | 50 | 63 | 100 |
| | tanδ (max.) | 0.22 | 0.19 | 0.16 | 0.14 | 0.12 | 0.10 | 0.09 | 0.08 |
| 0.02 is added to every 1000µF increase over 1000µF (20°C, 120Hz) | | | | | | | | | |
| Endurance (85°C) (Applied ripple current) | Test time | 1000 hours | | | | | | | |
| | Leakage current | The initial specified value or less | | | | | | | |
| | Percentage of capacitance change | Within ±20% of initial value | | | | | | | |
| | Tangent of the loss angle | 150% or less of the initial specified value | | | | | | | |
| Shelf life (85°C) | Test time : 1000 hours. Other have same as endurance. Voltage application treatment : According to JIS C5101 -1 | | | | | | | | |
| Applicable standards | JIS C5101-1, -4 1998 (IEC 60384-1 1992, -4 1985) | | | | | | | | |

Outline Drawing

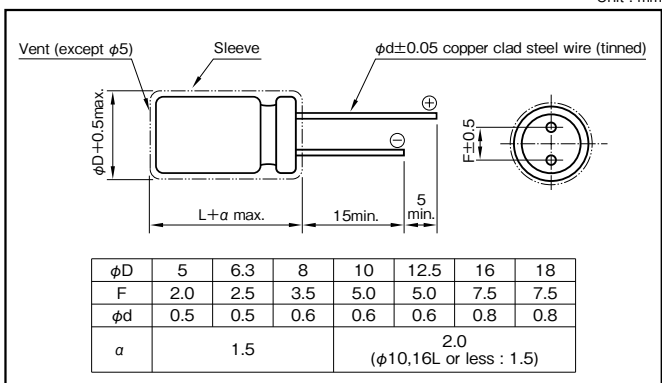

Coefficient of Frequency for Rated Ripple Current

| Rated voltage(V) | Frequency(Hz) CV(µF×VV) | 50 - 60 | 120 | 1k | 10k | 100k |
|------------------|----------------------------|-----------|--------------|-----|-----|------|
| | | 6.3 to 16 | All CV value | 0.8 | 1 | 1.1 |
| 25 to 35 | ≤1000 | 0.8 | 1 | 1.5 | 1.7 | 1.7 |
| | 1000< | 0.8 | 1 | 1.2 | 1.3 | 1.3 |
| 50 to 100 | ≤1000 | 0.8 | 1 | 1.6 | 1.9 | 1.9 |
| | 1000< | 0.8 | 1 | 1.2 | 1.3 | 1.3 |

Part numbering system (example : 25V100µF)

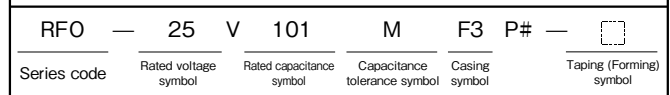

Case symbol

| Case φD×L (mm) | Casing Symbol | Case φD×L (mm) | Casing Symbol | Case φD×L (mm) | Casing Symbol | Case φD×L (mm) | Casing Symbol |
|----------------|---------------|----------------|---------------|----------------|---------------|----------------|---------------|
| 5×11 | E3 | 10×12.5 | H3 | 12.5×20 | 15 | 16×31.5 | J7 |
| 6.3×11 | F3 | 10×16 | H4 | 12.5×25 | 16 | 18×35.5 | K8 |
| 8×11.5 | G3 | 10×20 | H5 | 16×25 | J6 | | |

Standard Ratings

| Rated capacitance (µF) | 6.3 | | 10 | | 16 | | 25 | | 35 | | 50 | | 63 | | 100 | |
|------------------------|----------------|---------------------------|----------------|---------------------------|----------------|---------------------------|----------------|---------------------------|----------------|---------------------------|----------------|---------------------------|----------------|---------------------------|----------------|---------------------------|
| | Case φD×L (mm) | Rated ripple current (mA) | Case φD×L (mm) | Rated ripple current (mA) | Case φD×L (mm) | Rated ripple current (mA) | Case φD×L (mm) | Rated ripple current (mA) | Case φD×L (mm) | Rated ripple current (mA) | Case φD×L (mm) | Rated ripple current (mA) | Case φD×L (mm) | Rated ripple current (mA) | Case φD×L (mm) | Rated ripple current (mA) |
| 1 | — | — | — | — | — | — | — | — | — | — | 5×11 | 15 | — | — | 5×11 | 15 |
| 2.2 | — | — | — | — | — | — | — | — | — | — | 5×11 | 20 | — | — | 5×11 | 25 |
| 3.3 | — | — | — | — | — | — | — | — | — | — | 5×11 | 25 | — | — | 5×11 | 30 |
| 4.7 | — | — | — | — | — | — | — | — | — | — | 5×11 | 30 | 5×11 | 35 | 5×11 | 35 |
| 10 | — | — | — | — | — | — | — | — | — | — | 5×11 | 45 | 5×11 | 50 | 6.3×11 | 60 |
| 22 | — | — | — | — | 5×11 | 50 | 5×11 | 55 | 5×11 | 60 | 5×11 | 70 | 6.3×11 | 85 | 8×11.5 | 110 |
| 33 | — | — | 5×11 | 55 | 5×11 | 60 | 5×11 | 70 | 5×11 | 80 | 6.3×11 | 100 | 6.3×11 | 100 | 10×12.5 | 160 |
| 47 | — | — | 5×11 | 65 | 5×11 | 75 | 5×11 | 85 | 6.3×11 | 110 | 6.3×11 | 120 | 8×11.5 | 150 | 10×16 | 210 |
| 100 | 5×11 | 85 | 5×11 | 95 | 6.3×11 | 120 | 6.3×11 | 140 | 8×11.5 | 190 | 8×11.5 | 210 | 10×12.5 | 260 | 12.5×20 | 380 |
| 220 | 6.3×11 | 150 | 6.3×11 | 165 | 8×11.5 | 220 | 8×11.5 | 250 | 10×12.5 | 330 | 10×16 | 400 | 10×20 | 460 | 16×25 | 720 |
| 330 | 6.3×11 | 180 | 8×11.5 | 240 | 8×11.5 | 270 | 10×12.5 | 370 | 10×16 | 450 | 10×20 | 540 | 12.5×20 | 650 | 16×25 | 880 |
| 470 | 8×11.5 | 260 | 8×11.5 | 280 | 10×12.5 | 390 | 10×16 | 480 | 10×20 | 590 | 12.5×20 | 740 | 12.5×25 | 850 | 16×31.5 | 1150 |
| 1000 | 10×12.5 | 450 | 10×16 | 540 | 10×20 | 680 | 12.5×20 | 880 | 12.5×25 | 1050 | 16×25 | 1350 | 16×31.5 | 1550 | — | — |
| 2200 | 12.5×20 | 890 | 12.5×20 | 970 | 12.5×25 | 1200 | 16×25 | 1550 | 16×31.5 | 1750 | 18×35.5 | 2100 | — | — | — | — |
| 3300 | 12.5×20 | 1050 | 12.5×25 | 1250 | 16×25 | 1600 | 16×31.5 | 1950 | 18×35.5 | 2250 | — | — | — | — | — | — |
| 4700 | 16×25 | 1550 | 16×25 | 1650 | 16×31.5 | 2050 | 18×35.5 | 2500 | — | — | — | — | — | — | — | — |
| 6800 | 16×25 | 1750 | 16×31.5 | 2050 | 18×35.5 | 2550 | — | — | — | — | — | — | — | — | — | — |
| 10000 | 16×31.5 | 2150 | 18×35.5 | 2550 | — | — | — | — | — | — | — | — | — | — | — | — |
| 15000 | 18×35.5 | 2700 | — | — | — | — | — | — | — | — | — | — | — | — | — | — |

(Note) Rated ripple current : 85°C, 120Hz

Miniature Capacitors for Audio

GREEN CAP For Audio

- With the same size as that for Series RE3 miniaturized standard capacitors, a high resolution sound quality grade has been realized.
- The newly developed audio use material makes clear sound a reality.
- All lead wires are copper clad steel.

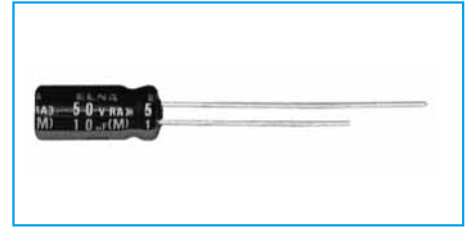
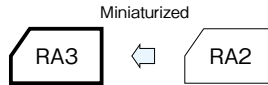

Marking color : White print on a brown sleeve

Specifications

| Item | Performance | | | | | | | | |
|---|---|---|------|------|------|------|------|------|------|
| Category temperature range (°C) | -40 to +85 | | | | | | | | |
| Tolerance at rated capacitance (%) | ±20 (20°C,120Hz) | | | | | | | | |
| Leakage current (µA) | Less than 0.01CV or 3 whichever is larger (after 2 minutes) C : Rated capacitance (µF) ; V : Rated voltage (V) (20°C) | | | | | | | | |
| Tangent of loss angle (tanδ) | Rated voltage (V) | 6.3 | 10 | 16 | 25 | 35 | 50 | 63 | 100 |
| | tanδ (max.) | 0.28 | 0.24 | 0.20 | 0.16 | 0.14 | 0.12 | 0.11 | 0.10 |
| 0.02 is added to every 1000µF increase over 1000µF (20°C,120Hz) | | | | | | | | | |
| Endurance (85°C) (Applied ripple current) | Test time | 2000 hours | | | | | | | |
| | Leakage current | The initial specified value or less | | | | | | | |
| | Percentage of capacitance change | Within ±20% of initial value | | | | | | | |
| | Tangent of the loss angle | 200% or less of the initial specified value | | | | | | | |
| Shelf life (85°C) | Test time : 1000 hours. Other have same as endurance. Voltage application treatment : According to JIS C5101 -1 | | | | | | | | |
| Applicable standards | JIS C5101-1, -4 1998 (IEC 60384-1 1992, -4 1985) | | | | | | | | |

Outline Drawing

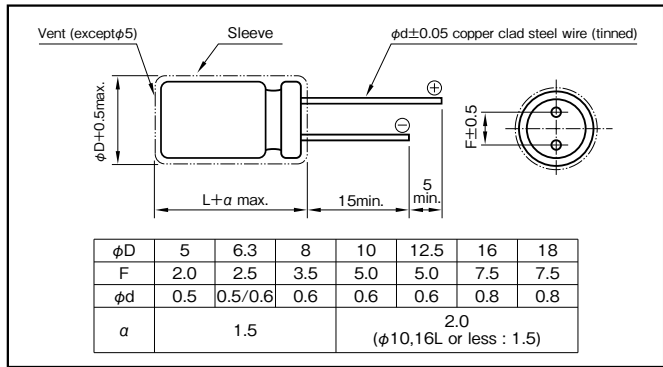

Coefficient of Frequency for Rated Ripple Current

| Rated voltage(V) | Frequency (Hz) CV (µF×WV) | 50 · 60 | 120 | 1k | 10k | 100k |
|------------------|------------------------------|-----------|--------------|-----|-----|------|
| | | 6.3 to 16 | All CV value | 0.8 | 1 | 1.1 |
| 25 to 35 | ≤1000 | 0.8 | 1 | 1.5 | 1.7 | 1.7 |
| | 1000< | 0.8 | 1 | 1.2 | 1.3 | 1.3 |
| 50 to 100 | ≤1000 | 0.8 | 1 | 1.6 | 1.9 | 1.9 |
| | 1000< | 0.8 | 1 | 1.2 | 1.3 | 1.3 |

Part numbering system (example : 25V100µF)

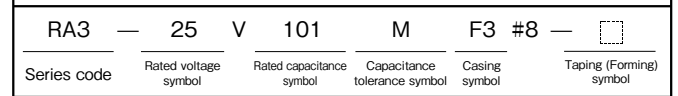

Case symbol

| Case φD×L (mm) | Casing Symbol | Case φD×L (mm) | Casing Symbol | Case φD×L (mm) | Casing Symbol | Case φD×L (mm) | Casing Symbol |
|----------------|---------------|----------------|---------------|----------------|---------------|----------------|---------------|
| 5×11 | E3 | 10×12.5 | H3 | 12.5×20 | I5 | 16×31.5 | J7 |
| 6.3×11 | F3 | 10×16 | H4 | 12.5×25 | I6 | 18×35.5 | K8 |
| 8×11.5 | G3 | 10×20 | H5 | 16×25 | J6 | — | — |

Standard Ratings

| Rated capacitance (µF) | Item | 6.3 | | 10 | | 16 | | 25 | | 35 | | 50 | | 63 | | 100 | |
|------------------------|---------|----------------|---|----------------|---|----------------|---|----------------|---|----------------|---|----------------|---|----------------|---|----------------|---|
| | | Case φD×L (mm) | Rated ripple current (mA _{rms}) | Case φD×L (mm) | Rated ripple current (mA _{rms}) | Case φD×L (mm) | Rated ripple current (mA _{rms}) | Case φD×L (mm) | Rated ripple current (mA _{rms}) | Case φD×L (mm) | Rated ripple current (mA _{rms}) | Case φD×L (mm) | Rated ripple current (mA _{rms}) | Case φD×L (mm) | Rated ripple current (mA _{rms}) | Case φD×L (mm) | Rated ripple current (mA _{rms}) |
| 1 | — | — | — | — | — | — | — | — | — | — | — | 5×11 | 21 | — | — | 5×11 | 21 |
| 2.2 | — | — | — | — | — | — | — | — | — | — | — | 5×11 | 31 | — | — | 5×11 | 31 |
| 3.3 | — | — | — | — | — | — | — | — | — | — | — | 5×11 | 38 | — | — | 5×11 | 40 |
| 4.7 | — | — | — | — | — | — | — | — | — | — | — | 5×11 | 45 | — | — | 5×11 | 50 |
| 10 | — | — | — | — | — | 5×11 | 50 | 5×11 | 55 | 5×11 | 60 | 5×11 | 66 | 5×11 | 70 | 5×11 | 70 |
| 22 | — | — | — | — | — | 5×11 | 75 | 5×11 | 90 | 5×11 | 95 | 5×11 | 100 | 5×11 | 105 | 6.3×11 | 115 |
| 33 | — | — | — | — | — | 5×11 | 110 | 5×11 | 110 | 5×11 | 110 | 5×11 | 110 | 6.3×11 | 130 | 8×11.5 | 158 |
| 47 | — | — | — | — | — | 5×11 | 130 | 5×11 | 130 | 5×11 | 130 | 6.3×11 | 155 | 6.3×11 | 160 | 8×11.5 | 188 |
| 100 | 5×11 | 130 | 5×11 | 150 | 5×11 | 180 | 6.3×11 | 199 | 6.3×11 | 214 | 8×11.5 | 250 | 8×11.5 | 270 | 10×16 | 358 | |
| 220 | 5×11 | 240 | 6.3×11 | 250 | 6.3×11 | 280 | 8×11.5 | 349 | 8×11.5 | 350 | 10×12.5 | 429 | 10×16 | 505 | 12.5×20 | 663 | |
| 330 | 6.3×11 | 300 | 6.3×11 | 330 | 8×11.5 | 383 | 8×11.5 | 383 | 10×12.5 | 542 | 10×16 | 595 | 10×20 | 676 | 12.5×25 | 886 | |
| 470 | 6.3×11 | 380 | 8×11.5 | 417 | 8×11.5 | 480 | 10×12.5 | 545 | 10×16 | 664 | 12.5×20 | 887 | 12.5×20 | 924 | 16×25 | 1230 | |
| 1000 | 8×11.5 | 580 | 10×12.5 | 650 | 10×16 | 791 | 10×20 | 996 | 12.5×20 | 1210 | 12.5×25 | 1400 | 16×25 | 1710 | 18×35.5 | 2210 | |
| 2200 | 10×16 | 939 | 10×20 | 1080 | 12.5×20 | 1350 | 12.5×25 | 1660 | 16×25 | 1950 | 16×31.5 | 2340 | 18×35.5 | 2870 | — | — | |
| 3300 | 10×20 | 1230 | 12.5×20 | 1430 | 12.5×25 | 1690 | 16×25 | 2030 | 16×31.5 | 2320 | 18×35.5 | 2810 | — | — | — | — | |
| 4700 | 12.5×20 | 1710 | 12.5×25 | 1780 | 16×25 | 2100 | 16×31.5 | 2650 | 18×35.5 | 2290 | — | — | — | — | — | — | |
| 6800 | 12.5×25 | 1930 | 16×25 | 2270 | 16×31.5 | 2480 | 18×35.5 | 3290 | — | — | — | — | — | — | — | — | |
| 10000 | 16×25 | 2450 | 16×31.5 | 2500 | 18×35.5 | 3130 | — | — | — | — | — | — | — | — | — | — | |
| 15000 | 16×31.5 | 2580 | 18×35.5 | 3100 | — | — | — | — | — | — | — | — | — | — | — | — | |
| 22000 | 18×35.5 | 3150 | — | — | — | — | — | — | — | — | — | — | — | — | — | — | |

(Note) Rated ripple current : 85°C, 120Hz

NOTE : Design, Specifications are subject to change without notice. It is recommended that you shall obtain technical specifications from ELNA to ensure that the component is suitable for your use.

105°C Miniature Capacitors for Audio

GREEN CAP

105°C
1000hours

For Audio

- With the same size as that for Series RJ5 miniaturized standard capacitors, a high resolution sound quality grade has been realized.
- Guarantees 1000 hours at 105°C

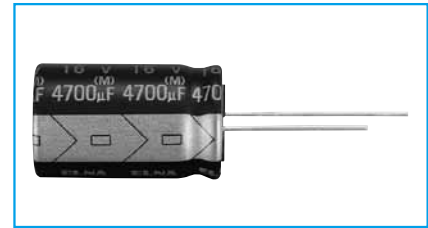
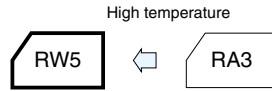

Marking color : Gold print on a black sleeve

Specifications

| Item | Performance | | | |
|--|--|---|------|---|
| Category temperature range (°C) | -55 to +105 | | | |
| Tolerance at rated capacitance (%) | ±20 (20°C, 120Hz) | | | |
| Leakage current (µA) | Less than 0.03CV or 4 whichever is larger (after 1 minutes) C : Rated capacitance (µF) , V : Rated voltage (V) (20°C) | | | |
| Tangent of loss angle (tanδ) | Rated voltage (V) | 16 | 25 | |
| | tanδ (max.) | 0.24 | 0.20 | |
| 0.02CV is added to every 1000µF increase over 1000µF (20°C, 120Hz) | | | | |
| Characteristics at high and low temperature | Rated voltage (V) | 16 | 25 | |
| | Impedance ratio (max.) | Z-25°C/Z+20°C | 3 | 2 |
| | | Z-40°C/Z+20°C | 6 | 4 |
| (120Hz) | | | | |
| Endurance (105°C) (Applied ripple current) | Test time | 1000 hours | | |
| | Leakage current | The initial specified value or less | | |
| | Percentage of capacitance change | Within ±20% of initial value | | |
| | Tangent of the loss angle | 200% or less of the initial specified value | | |
| Shelf life (105°C) | Test time : 1000 hours; Other have same as endurance. Voltage application treatment : According to JIS C5101 -1 | | | |
| Applicable standards | JIS C5101-1, -4 1998 (IEC 60384-1 1992, -4 1985) | | | |

Outline Drawing

Unit : mm

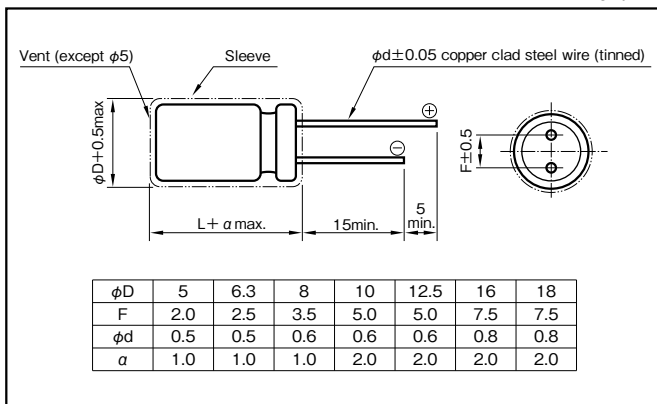

Coefficient of Frequency for Rated Ripple Current

| Rated Capacitance (µF) | Frequency (Hz) | | | | |
|------------------------|----------------|-----|-----|-----|------|
| | 50 · 60 | 120 | 1k | 10k | 100k |
| 100 to 220 | 0.8 | 1 | 1.2 | 1.3 | 1.4 |
| 330 to 1000 | 0.8 | 1 | 1.2 | 1.2 | 1.3 |
| 2200 to 15000 | 0.8 | 1 | 1.1 | 1.1 | 1.1 |

Part numbering system (example : 16V3300µF)

| | | | | | | | | | |
|-------------|---|----------------------|---|--------------------------|------------------------------|---------------|---|---|-------------------------|
| RW5 | — | 16 | V | 332 | M | I6 | # | — | □ |
| Series code | | Rated voltage symbol | | Rated capacitance symbol | Capacitance tolerance symbol | Casing symbol | | | Taping (Forming) symbol |

Standard Ratings

| Rated capacitance (µF) | 16 | | | 25 | | |
|------------------------|----------------|---------------|---|----------------|---------------|---|
| | Case φD×L (mm) | Casing symbol | Rated ripple current (mA _{RMS}) | Case φD×L (mm) | Casing symbol | Rated ripple current (mA _{RMS}) |
| 100 | — | — | — | 5×11.5 | E3 | 125 |
| 220 | 6.3×11.5 | F3 | 190 | 6.3×11.5 | F3 | 200 |
| 330 | 6.3×11.5 | F3 | 225 | 8×12 | G3 | 310 |
| 470 | 8×12 | G3 | 323 | 10×12.5 | H3 | 429 |
| 1000 | 10×12.5 | H3 | 500 | 10×16 | H4 | 610 |
| 2200 | 10×20 | H5 | 710 | 12.5×25 | I6 | 1180 |
| | | | | 16×20 | J5 | 1230 |
| | | | | 18×16 | K4 | 1200 |
| 3300 | 12.5×25 | I6 | 1200 | 16×25 | J6 | 1440 |
| | 16×20 | J5 | 1250 | 18×20 | K5 | 1400 |
| 4700 | 16×25 | J6 | 1500 | 16×25 | J6 | 1570 |
| | 18×20 | K5 | 1460 | 18×20 | K5 | 1530 |
| 6800 | 16×25 | J6 | 1600 | 16×35.5 | J8 | 1850 |
| | 18×20 | K5 | 1560 | 18×31.5 | K7 | 1870 |
| 10000 | 16×35.5 | J8 | 1930 | 18×40 | K9 | 2000 |
| 15000 | 18×40 | K9 | 2210 | — | — | — |

(Note) Rated ripple current : 105°C, 120Hz.

NOTE : Design, Specifications are subject to change without notice. It is recommended that you shall obtain technical specifications from ELNA to ensure that the component is suitable for your use.

Miniature Bipolar Capacitors for Audio

GREEN CAP For Audio

- The newly developed audio use foil and special electrolyte makes clear and far-carrying sound a reality.
- All lead wires are copper clad steel.

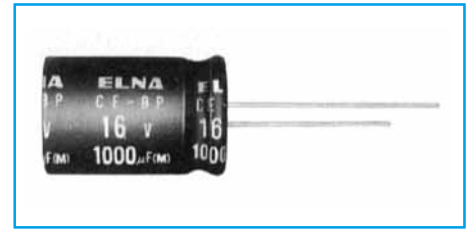

Marking color : Gold print on a black sleeve

Specifications

| Item | Performance | | | | | | | | | |
|--|---|---|------|------|------|------|------|------|------|---|
| Category temperature range (°C) | -40 to +85 | | | | | | | | | |
| Tolerance at rated capacitance (%) | ±20 (20°C, 120Hz) | | | | | | | | | |
| Leakage current (µA) | Less than 0.03CV + 3 (after 5 minutes) C : Rated capacitance (µF); V : Rated voltage (V) (20°C) | | | | | | | | | |
| Tangent of loss angle (tanδ) | Rated voltage (V) | 6.3 | 10 | 16 | 25 | 35 | 50 | 63 | 100 | |
| | tanδ (max.) | 0.24 | 0.20 | 0.16 | 0.15 | 0.14 | 0.12 | 0.10 | 0.09 | |
| 0.02 is added to every 1000µF increase over 1000µF. (20°C, 120Hz) | | | | | | | | | | |
| Characteristics at high and low temperature | Rated voltage (V) | 6.3 | 10 | 16 | 25 | 35 | 50 | 63 | 100 | |
| | Impedance ratio (max.) | Z-25°C/Z+20°C | 4 | 3 | 2 | 2 | 2 | 2 | 2 | 2 |
| 0.5 for -25°C, 1 for -40°C are added to every 1000µF increase over 1000µF. (120Hz) | | | | | | | | | | |
| Endurance (85°C) (Applied ripple current) | Test time | 2000 hours (with the polarity inverted every 250 hours) | | | | | | | | |
| | Leakage current | The initial specified value or less | | | | | | | | |
| | Percentage of capacitance change | Within ±20% of initial value | | | | | | | | |
| | Tangent of the loss angle | 150% or less of the initial specified value | | | | | | | | |
| Applicable standards | JIS C5101-1, -4 1998 (IEC 60384-1 1992, -4 1985) | | | | | | | | | |

Outline Drawing

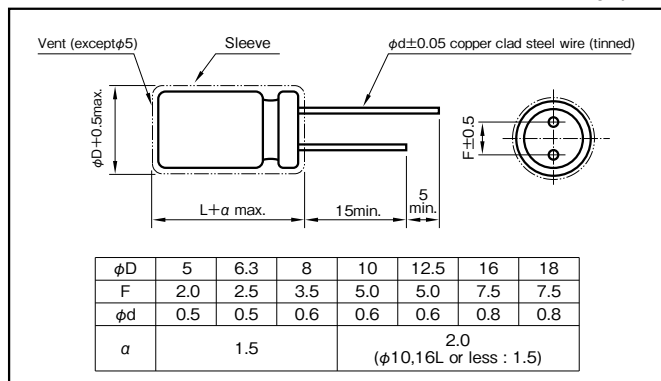

Coefficient of Frequency for Rated Ripple Current

| Frequency (Hz) | 50 · 60 | 120 | 1k | 10k · 100k |
|-------------------|---------|-----|-----|------------|
| Rated voltage (V) | | | | |
| 6.3 to 16 | 0.8 | 1 | 1.1 | 1.2 |
| 25 to 35 | 0.8 | 1 | 1.5 | 1.7 |
| 50 to 100 | 0.8 | 1 | 1.6 | 1.9 |

Part numbering system (example : 10V1000µF)



Case symbol

| Case φD×L (mm) | Casing Symbol | Case φD×L (mm) | Casing Symbol | Case φD×L (mm) | Casing Symbol | Case φD×L (mm) | Casing Symbol |
|----------------|---------------|----------------|---------------|----------------|---------------|----------------|---------------|
| 5×11 | E3 | 10×12.5 | H3 | 12.5×20 | I5 | 16×31.5 | J7 |
| 6.3×11 | F3 | 10×16 | H4 | 12.5×25 | I6 | 18×35.5 | K8 |
| 8×11.5 | G3 | 10×20 | H5 | 16×25 | J6 | — | — |

Standard Ratings

| Rated voltage (V) | 6.3 | | 10 | | 16 | | 25 | | 35 | | 50 | | 63 | | 100 | |
|-------------------|----------------|--------------------------------|----------------|--------------------------------|----------------|--------------------------------|----------------|--------------------------------|----------------|--------------------------------|----------------|--------------------------------|----------------|--------------------------------|----------------|--------------------------------|
| | Case φD×L (mm) | Rated ripple current (mA Arms) | Case φD×L (mm) | Rated ripple current (mA Arms) | Case φD×L (mm) | Rated ripple current (mA Arms) | Case φD×L (mm) | Rated ripple current (mA Arms) | Case φD×L (mm) | Rated ripple current (mA Arms) | Case φD×L (mm) | Rated ripple current (mA Arms) | Case φD×L (mm) | Rated ripple current (mA Arms) | Case φD×L (mm) | Rated ripple current (mA Arms) |
| 1 | — | — | — | — | — | — | — | — | — | — | 5×11 | 14 | — | — | 5×11 | 16 |
| 2.2 | — | — | — | — | — | — | — | — | — | — | 5×11 | 21 | 5×11 | 23 | 5×11 | 24 |
| 3.3 | — | — | — | — | — | — | — | — | — | — | 5×11 | 26 | 5×11 | 28 | 6.3×11 | 34 |
| 4.7 | — | — | — | — | — | — | 5×11 | 28 | 5×11 | 28 | 5×11 | 31 | 5×11 | 34 | 6.3×11 | 41 |
| 10 | — | — | — | — | 5×11 | 39 | 5×11 | 40 | 5×11 | 42 | 5×11 | 45 | 6.3×11 | 57 | 8×11.5 | 70 |
| 22 | — | — | 5×11 | 52 | 5×11 | 58 | 5×11 | 60 | 6.3×11 | 71 | 6.3×11 | 77 | 8×11.5 | 89 | 10×16 | 136 |
| 33 | 5×11 | 58 | 5×11 | 63 | 5×11 | 71 | 6.3×11 | 84 | 6.3×11 | 87 | 8×11.5 | 111 | 10×12.5 | 144 | 10×20 | 181 |
| 47 | 5×11 | 69 | 5×11 | 75 | 6.3×11 | 97 | 6.3×11 | 100 | 8×11.5 | 122 | 10×12.5 | 157 | 10×16 | 188 | 12.5×20 | 248 |
| 100 | 6.3×11 | 115 | 6.3×11 | 126 | 8×11.5 | 167 | 10×12.5 | 204 | 10×12.5 | 212 | 10×20 | 273 | 12.5×20 | 343 | 16×25 | 458 |
| 220 | 8×11.5 | 202 | 8×11.5 | 221 | 10×12.5 | 294 | 10×16 | 332 | 10×20 | 375 | 12.5×25 | 506 | 16×25 | 645 | 18×35.5 | 837 |
| 330 | 8×11.5 | 247 | 10×12.5 | 322 | 10×16 | 394 | 10×20 | 444 | 12.5×20 | 526 | 12.5×25 | 620 | — | — | — | — |
| 470 | 10×12.5 | 350 | 10×16 | 420 | 10×20 | 513 | 12.5×20 | 607 | 12.5×25 | 685 | 16×25 | 861 | — | — | — | — |
| 1000 | 10×20 | 611 | 12.5×20 | 767 | 12.5×25 | 935 | 16×25 | 1120 | 16×31.5 | 1270 | — | — | — | — | — | — |
| 2200 | 12.5×25 | 1090 | 16×25 | 1380 | 16×31.5 | 1660 | — | — | — | — | — | — | — | — | — | — |
| 3300 | 16×25 | 1490 | 16×31.5 | 1760 | — | — | — | — | — | — | — | — | — | — | — | — |
| 4700 | 16×31.5 | 1880 | 18×35.5 | 2280 | — | — | — | — | — | — | — | — | — | — | — | — |

(Note) Rated ripple current : 85°C, 120Hz

NOTE : Design, Specifications are subject to change without notice. It is recommended that you shall obtain technical specifications from ELNA to ensure that the component is suitable for your use.

Power Supply Smoothing Use, Standard Capacitors for Audio

GREEN CAP

For Audio

- Best suited as power supply filters for sound quality priority audio equipment.
- Printed circuit board terminal snap-in type.

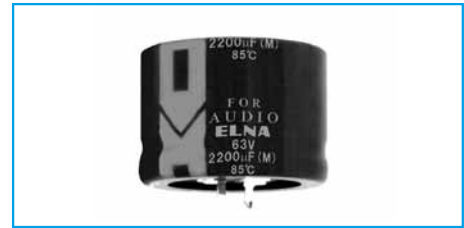

Marking color : Gold print on a black sleeve

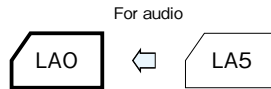

Specifications

| Item | Performance | | | | |
|---|---|---|-----------|------|-----------|
| Category temperature range (°C) | -40 to +85 | | | | |
| Tolerance at rated capacitance (%) | ±20 (20°C, 120Hz) | | | | |
| Leakage current (µA) | Less than 0.03CV or 5mA whichever is smaller (after 5 minutes) C : Rated capacitance (µF), V : Rated voltage (V) (20°C) | | | | |
| Tangent of loss angle (tanδ) | Rated voltage (V) | 16 | 25 | 35 | 50 to 100 |
| | tanδ (max.) | 0.40 | 0.40 | 0.35 | 0.30 |
| Characteristics at high and low temperature | Rated voltage (V) | 16 to 35 | 50 to 100 | | |
| | Impedance ratio (max.) | Z-25°C/Z+20°C | 4 | 3 | |
| | | Z-40°C/Z+20°C | 15 | 10 | |
| Endurance (85°C) (Applied ripple current) | Test time | 1000 hours | | | |
| | Leakage current | The initial specified value or less | | | |
| | Percentage of capacitance change | Within ±20% of initial value | | | |
| | Tangent of the loss angle | 150% or less of the initial specified value | | | |
| Shelf life (85°C) | Test time : 1000 hours. Other have same as endurance. Voltage application treatment : According to JIS C5101 -1 | | | | |
| Applicable standards | JIS C5101-1, -4 1998 (IEC 60384-1 1992, -4 1985) | | | | |

Outline Drawing

Unit : mm

Printed circuit board snap-in type (Series LAO)

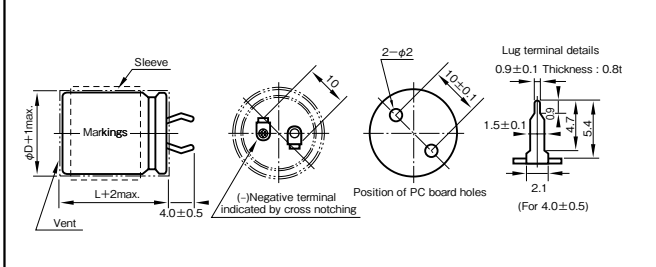

Coefficient of Frequency for Rated Ripple Current

| Frequency (Hz) | 50 | 120 | 1k | 10k | 20k |
|-------------------|------|-----|------|------|------|
| Rated voltage (V) | | | | | |
| 16 to 50 | 0.95 | 1 | 1.10 | 1.15 | 1.15 |
| 63 to 100 | 0.95 | 1 | 1.16 | 1.30 | 1.33 |

Part numbering system (example : 63V6800µF)

| | | | | | | | | |
|-------------|---|----------------------|---|--------------------------|------------------------------|---------------|------|-----------------|
| LAO | — | 63 | V | 682 | M | S57 | PX # | B |
| Series code | | Rated voltage symbol | | Rated capacitance symbol | Capacitance tolerance symbol | Casing symbol | | Optional symbol |

NOTE : Design, Specifications are subject to change without notice. It is recommended that you shall obtain technical specifications from ELNA to ensure that the component is suitable for your use.

Standard Ratings

| Case φD×L (mm) | | Rated voltage (V) | | 16 | | 25 | | 35 | | 50 | | 63 | | 80 | | 100 | |
|-------------------|-----|-------------------|------------------------|-----------------------------|------------------------|-----------------------------|------------------------|-----------------------------|------------------------|-----------------------------|------------------------|-----------------------------|------------------------|-----------------------------|------------------------|-----------------------------|---|
| | | Item | Rated capacitance (μF) | Rated ripple current (Arms) | Rated capacitance (μF) | Rated ripple current (Arms) | Rated capacitance (μF) | Rated ripple current (Arms) | Rated capacitance (μF) | Rated ripple current (Arms) | Rated capacitance (μF) | Rated ripple current (Arms) | Rated capacitance (μF) | Rated ripple current (Arms) | Rated capacitance (μF) | Rated ripple current (Arms) | |
| 22×20 | S21 | 3300 | 1.2 | — | — | — | — | — | — | — | — | — | — | — | — | — | — |
| 22×25 | S22 | 4700 | 1.5 | 2200 | 1.0 | 1500 | 0.8 | 1000 | 0.8 | 680 | 0.7 | — | — | — | — | — | — |
| 22×30 | S23 | — | — | 3300 | 1.3 | 2200 | 1.3 | 1500 | 1.1 | 1000 | 0.9 | 680 | 0.7 | — | — | — | — |
| 22×35 | S24 | 6800 | 2.0 | 4700 | 1.7 | 3300 | 1.7 | — | — | 1500 | 1.2 | 1000 | 1.0 | 680 | 0.8 | — | — |
| 22×40 | S25 | — | — | — | — | — | — | 2200 | 1.5 | — | — | — | — | — | — | — | — |
| 22×45 | S26 | 10000 | 2.7 | 6800 | 2.2 | 4700 | 2.3 | — | — | 2200 | 1.6 | — | — | — | — | — | — |
| 22×50 | S27 | — | — | — | — | — | — | 3300 | 2.0 | — | — | 1500 | 1.3 | 1000 | 1.2 | — | — |
| 25×25 | S32 | — | — | 3300 | 1.7 | 2200 | 1.7 | 1500 | 1.4 | 1000 | 1.2 | 680 | 1.0 | — | — | — | — |
| 25×30 | S33 | 6800 | 2.5 | 4700 | 2.1 | 3300 | 2.2 | 2200 | 1.8 | 1500 | 1.5 | 1000 | 1.2 | 680 | 1.1 | — | — |
| 25×35 | S34 | 10000 | 3.2 | — | — | — | — | — | — | — | — | — | — | — | — | — | — |
| 25×40 | S35 | — | — | 6800 | 2.7 | 4700 | 2.8 | 3300 | 2.3 | 2200 | 1.9 | 1500 | 1.6 | 1000 | 1.4 | — | — |
| 25×45 | S36 | — | — | — | — | — | — | — | — | — | — | — | — | — | — | — | — |
| 25×50 | S37 | — | — | 10000 | 3.0 | 6800 | 2.6 | 4700 | 2.4 | 3300 | 2.0 | 2200 | 2.0 | 1500 | 1.8 | — | — |
| 30×25 | S42 | 6800 | 2.6 | 4700 | 2.2 | 3300 | 2.3 | 2200 | 1.9 | 1500 | 1.6 | 1000 | 1.3 | 680 | 1.1 | — | — |
| 30×30 | S43 | 10000 | 3.3 | 6800 | 2.7 | 4700 | 2.8 | 3300 | 2.4 | 2200 | 1.9 | 1500 | 1.6 | 1000 | 1.4 | — | — |
| 30×35 | S44 | — | — | — | — | — | — | — | — | — | — | — | — | — | — | — | — |
| 30×40 | S45 | — | — | 10000 | 3.1 | 6800 | 2.7 | 4700 | 2.4 | 3300 | 2.1 | 2200 | 2.1 | 1500 | 1.8 | — | — |
| 30×45 | S46 | — | — | — | — | — | — | — | — | — | — | — | — | — | — | — | — |
| 30×50 | S47 | — | — | — | — | 10000 | 3.4 | 6800 | 3.1 | 4700 | 2.6 | 3300 | 2.2 | 2200 | 1.8 | — | — |
| 35×25 | S52 | 10000 | 3.4 | 6800 | 2.8 | 4700 | 2.9 | 3300 | 2.4 | 2200 | 2.0 | 1500 | 1.7 | 1000 | 1.5 | — | — |
| 35×30 | S53 | — | — | 10000 | 3.1 | 6800 | 2.7 | 4700 | 2.5 | 3300 | 2.1 | 2200 | 2.1 | 1500 | 1.8 | — | — |
| 35×35 | S54 | — | — | — | — | — | — | — | — | — | — | — | — | — | — | — | — |
| 35×40 | S55 | — | — | — | — | 10000 | 3.5 | 6800 | 3.1 | 4700 | 2.6 | 3300 | 2.2 | 2200 | 1.8 | — | — |
| 35×45 | S56 | — | — | — | — | — | — | — | — | — | — | — | — | — | — | — | — |
| 35×50 | S57 | — | — | — | — | — | — | — | — | 6800 | 3.3 | 4700 | 2.7 | — | — | — | — |

(Note) Rated ripple current : 85°C, 120Hz.

1 General Description of Aluminum Electrolytic Capacitors

1-1 The Principle of Capacitor

The principle of capacitor can be presented by the principle drawing as in Fig.1-1.

When a voltage is applied between the metal electrodes placed opposite on both surfaces of a dielectric, electric charge can be stored proportional to the voltage.

$$Q = C \cdot V$$

Q : Quantity of electricity (C)

V : Voltage (V)

C : Capacitance (F)

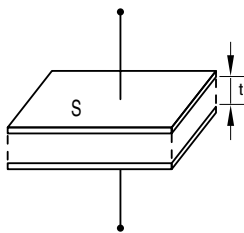

Fig.1-1

C, called the capacitance of capacitor, is expressed by the following expression with the electrode area S[m²], the electrode spacing t [m] and the dielectric constant of dielectric “ε”:

$$C[F] = \epsilon_0 \cdot \epsilon \cdot \frac{S}{t}$$

ε₀ : Dielectric constant in vacuum (=8.85×10⁻¹²F/m)

The dielectric constant of an aluminum oxide film is 7 to 8. Larger capacitances can be obtained by enlarging the electrode area S or reducing t.

Table 1-1 shows the dielectric constants of typical dielectrics used in the capacitor. In many cases, capacitor names are determined by the dielectric material used, for example, aluminum electrolytic capacitor, tantalum capacitor, etc.

Table 1

| Dielectric | Dielectric Constant | Dielectric | Dielectric Constant |
|---------------------|---------------------|---------------------|---------------------|
| Aluminum oxide film | 7 to 8 | Porcelain (ceramic) | 10 to 120 |
| Mylar | 3.2 | Polystyrene | 2.5 |
| Mica | 6 to 8 | Tantalum oxide film | 10 to 20 |

Although the aluminum electrolytic capacitor is small, it has a large capacitance. It is because the electrode area is roughened by electrochemical etching, enlarging the electrode area and also because the dielectric is very thin.

The schematic cross section of the aluminum electrolytic capacitor is as in Fig.1-2.

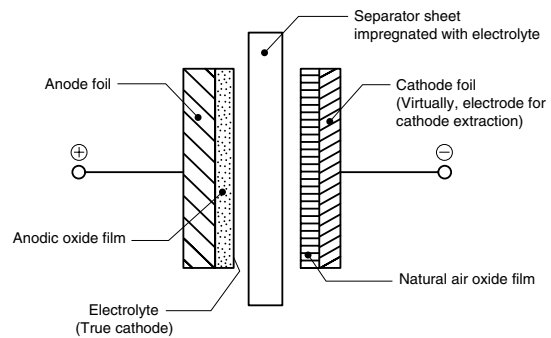
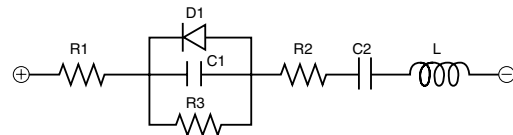

Fig.1-2

1-2 Equivalent Circuit of the Capacitor

The electrical equivalent circuit of the aluminum electrolytic capacitor is as presented in the following figure.



R1 : Resistance of terminal and electrode

R2 : Resistances of anodic oxide film and electrolyte

R3 : Insulation resistance because of defective anodic oxide film

D1 : Oxide semiconductor of anode foil

C1 : Capacity of anode foil

C2 : Capacity of cathode foil

L : Inductance caused by terminals, electrodes, etc.

2 About the Life of an Aluminum Electrolytic Capacitor

2-1 Estimation of life with minimal ripple current (negligible).

Generally, the life of an aluminum electrolytic capacitor is closely related with its ambient temperature and the life will be approximately the same as the one obtained by Arrhenius' equation.

$$L = L_0 \times 2^{\left(\frac{T_0 - T}{10}\right)} \dots\dots\dots(1)$$

Where L : Life at temperature T

L₀ : Life at temperature T₀

The effects to the life by derating of the applied voltage etc. are neglected because they are small compared to that by the temperature.

2-2 Estimation of life considering the ripple current.

The ripple current affects the life of a capacitor because the internal loss (ESR) generates heat. The generated heat will be :

$$P = I^2R \dots\dots\dots(2)$$

Where I : Ripple current (Arms)

R : ESR (Ω)

With increase in the temperature of the capacitor:

$$\Delta T = \frac{I^2 \times R}{A \times H} \dots\dots\dots(3)$$

Where ΔT : Temperature increase in the capacitor core(deg.)

I : Ripple current (Arms)

R : ESR (Ω)

A : Surface area of the capacitor (cm²)

H : Radiation coefficient (Approx. 1.5 to 2.0 × 10⁻³W/cm²×°C)

The above equation (3) shows that the temperature of a capacitor increases in proportion to the square of the applied ripple current and ESR, and in inverse proportion to the surface area. Therefore, the amount of the ripple current determines the heat generation, which affects the life. The value of ΔT varies depending on the capacitor types and operating conditions. The usage is generally desirable if ΔT remains less than 5°C. The measuring point for temperature increase due to ripple current is shown below ;

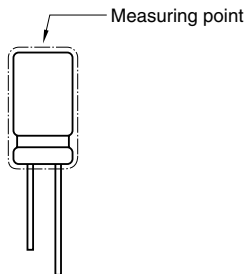

Test results:

(1) The life equation considering the ambient temperature and the ripple current will be :

$$L = L_d \times 2 \left(\frac{T_0 - T}{10} \right) \times K \left(\frac{-\Delta T}{10} \right) \dots\dots\dots(4)$$

Where L_d : Life at DC operation (h)

K : Ripple acceleration factor

(K=2, within allowable ripple current)

(K=4, if exceeding allowable ripple current)

T₀ : Upper category temperature (°C)

T : Operating temperature (°C)

ΔT : Temperature increase at capacitor core (deg.)

(2) The life equation based on the life with the rated ripple current applied under the maximum guaranteed temperature will be a conversion of the above equation (4), as below :

$$L = L_r \times 2 \left(\frac{T_0 - T}{10} \right) \times K \left(\frac{\Delta T_0 - \Delta T}{10} \right) \dots\dots\dots(5)$$

Where L_r : Life at the upper category temperature with the rated ripple current (h)

ΔT₀ : Temperature increase at capacitor core, at the upper category temperature (deg.)

(3) The life equation considering the ambient temperature and the ripple current will be a conversion of the above equation (5), as below :

$$L = L_r \times 2 \left(\frac{T_0 - T}{10} \right) \times K \left\{ 1 - \left(\frac{I}{I_0} \right)^2 \right\} \times \frac{\Delta T_0}{10} \dots\dots\dots(6)$$

Where I₀ : Rated ripple current at the upper category temperature (Arms)

I : Applied ripple current (Arms)

Since it is actually difficult to measure the temperature increase at the capacitor core, the following table is provided for conversion from the surface temperature increase to the core temperature increase.

Table 2-1

| | | | | | | | |
|----------------|-----|---------|------|-----|-----|-----|------|
| Case diameter | ~10 | 12.5~16 | 18 | 22 | 25 | 30 | 35 |
| Core / Surface | 1.1 | 1.2 | 1.25 | 1.3 | 1.4 | 1.6 | 1.65 |

The life expectancy formula shall in principle be applied to the temperature range between the ambient temperature of +40°C and upper category temperature. The expected life time shall be about fifteen years at maximum as a guide in terms of deterioration of the sealant.

(Fig. 2-1 Life Expectancy Chart)

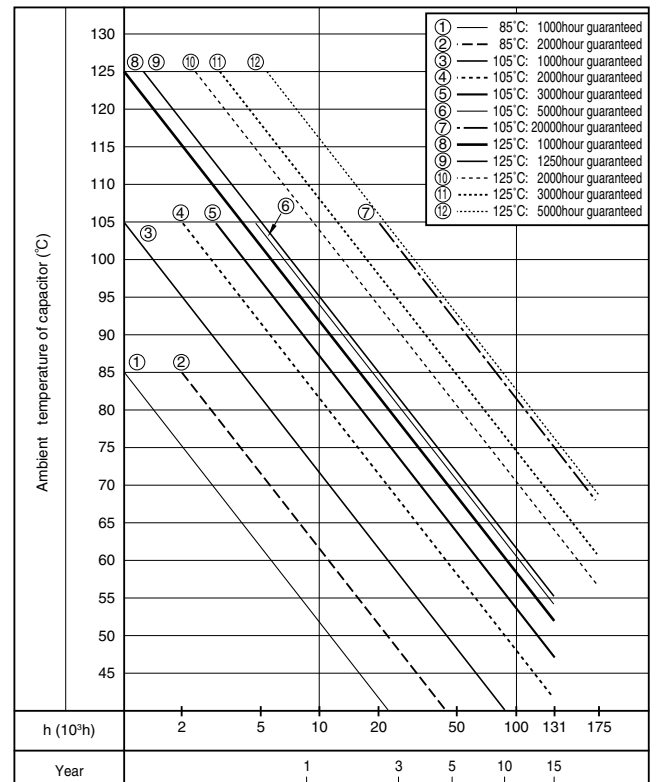

NOTE : Design, Specifications are subject to change without notice. It is recommended that you shall obtain technical specifications from ELNA to ensure that the component is suitable for your use.

2-3 Practical Examples of Life Expectancy

As practical examples of life expectancy, we introduce 250V 560 μF in the LAT Series considering the effect of high-frequency component. Figures 2-2 to 2-4 show the simulated ripple current waveforms when the high-frequency component for switching is superimposed on the commercial frequency component.

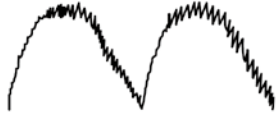

Fig.2-2 Ripple Current Waveform of Capacitor

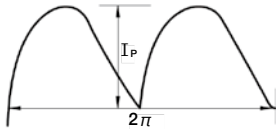

Fig.2-3 Low-frequency component

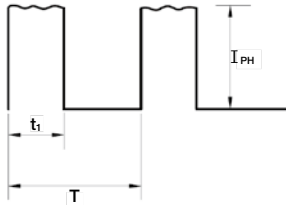

Fig.2-4 High-frequency component

Each of the above may be obtained as the effective ripple current value. Assuming that the ripple current waveform of the low-frequency component is generally approximated to the full-wave rectification waveform as shown in Fig.2-3, we obtain the effective ripple current value I_L as follows:

$$I_L = \frac{I_{PL}}{\sqrt{2}} = 0.707 \times I_{PL}$$

Since the ripple current waveform of the high-frequency component is approximated to the rectangular as shown in Fig.2-4, the effective current value of high-frequency component I_H is given by

$$I_H = \sqrt{\frac{1}{T} \int_0^{t_1} I_{PH}^2 dt} = I_{PH} \sqrt{\frac{t_1}{T}}$$

The reason why the ripple current affects the life is due to the heat generated by the ESR (R) of capacitor.

That is, ΔT by heat generation can be expressed by

$$\Delta T \propto I^2 \times R \text{ from Expression (2).}$$

Therefore, when ripple currents with different frequencies are handled, each current value must first be squared and then summed. That is:

$$I = \sqrt{(I_L)^2 + (I_H)^2}$$

Now, we proceed to specific examples assuming that the effective ripple current values of low-and high-frequencies have been obtained by the above methods.

Data A (Test piece and basic data)

| | |
|--------------|-------------------------------------|
| Product name | : 250V 560 μF φ 30x30 L, Series LAT |
| L_r | = 2000 hours |
| K | = 4 |
| T_0 | = 105°C |
| ΔT_0 | = 5deg |
| I_0 | = 1.79Arms at 105°C, 120Hz |

To verify the effect of the high-frequency component, the expected life will be calculated for each of three high-frequency ripple current conditions.

Data B

| | |
|----------|--|
| I_L | = 2.4Arms at 120Hz, $T=45^\circ\text{C}$ |
| I_{H1} | = 0.36Arms at 20kHz (corresponding to 15% of the commercial frequency component) |
| I_{H2} | = 0.72Arms at 20kHz (corresponding to 30% of the commercial frequency component) |
| I_{H3} | = 1.2Arms at 20kHz (corresponding to 50% of the commercial frequency component) |

For Data B, the currents are converted to 120Hz by the frequency conversion factor for the cases of ignorance of the high-frequency component, and each high-frequency component condition.

$$I = 2.4/1 = 2.4A$$

$$I_1 = \sqrt{(2.4)^2 + (0.36/1.18)^2} \doteq 2.42A$$

$$I_2 = \sqrt{(2.4)^2 + (0.72/1.18)^2} \doteq 2.48A$$

$$I_3 = \sqrt{(2.4)^2 + (1.2/1.18)^2} \doteq 2.61A$$

Explained here is about the frequency conversion factor. As described above, the heat generation (or temperature rise = ΔT) affecting the life is proportional to the ESR of capacitor. In addition, the fundamental frequency is 120Hz in measurement of capacitor characteristics, and the ripple current is also specified with this frequency; it is thus more convenient to calculate by converting the current value to that with the same temperature rise at 120Hz.

The ESR of aluminum electrolytic capacitor is frequency dependent.

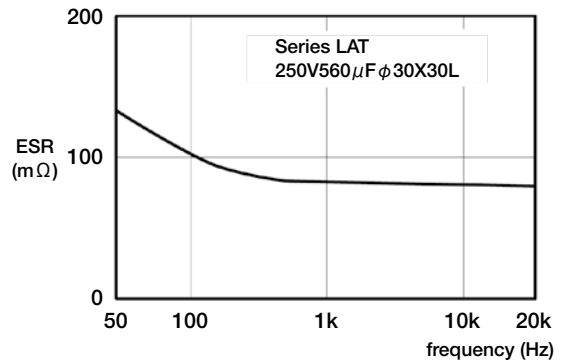

Fig.2-5 Frequency Characteristics of ESR

Figure 2-5 shows a typical example of frequency characteristics of ESR, indicating that the ESR decreases with increasing frequencies. Therefore, the high-frequency component has less effect on the heat generation of capacitor than low-frequency component.

Next, we calculate the expected life according to each condition to compare with the case with no high-frequency component.

For the case with no high-frequency component:

$$L = 2000 \times 2 \left(\frac{105-45}{10} \right) \times 2 \left[1 - \left(\frac{2.4}{1.79} \right)^2 \right] \times \frac{5}{10} \doteq 73,634 \text{ hours}$$

For the case with high-frequency component:

$$L = 2000 \times 2 \left(\frac{105-45}{10} \right) \times 2 \left[1 - \left(\frac{2.42}{1.79} \right)^2 \right] \times \frac{5}{10} \doteq 72,114 \text{ hours}$$

$72,114/73,634=0.979$, about a 2.1% reduction in life

$$L = 2000 \times 2 \left(\frac{105-45}{10} \right) \times 2 \left[1 - \left(\frac{2.48}{1.79} \right)^2 \right] \times \frac{5}{10} \doteq 67,671 \text{ hours}$$

$67,671/73,634=0.919$, about a 8.1% reduction in life

$$L = 2000 \times 2 \left(\frac{105-45}{10} \right) \times 2 \left[1 - \left(\frac{2.61}{1.79} \right)^2 \right] \times \frac{5}{10} \doteq 58,045 \text{ hours}$$

$58,045/73,634=0.796$, about a 20.4% reduction in life

As described above, there may be cases where the effect of larger high-frequency component on the life cannot be ignored; thus high-frequency component exceeding 30% with respect to the current with fundamental frequency should be considered.

NOTE : Design, Specifications are subject to change without notice.
It is recommended that you shall obtain technical specifications from ELNA to ensure that the component is suitable for your use.

3 To calculate Balance when connecting in series

3-1 Circuit layout

Circuit for connecting two capacitors (C1, C2) in series and equivalent circuit can be illustrated as below figure. Formula to calculate a balance resistance R_B of below figure is shown as follows.

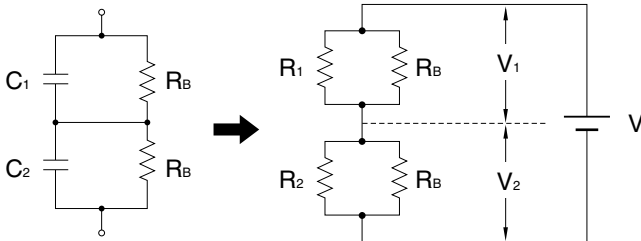

Following are the preconditions of the circuit.

- ① V_2 shall be the rated voltage ($=V_0$). ($V_1 < V_2$)
- ② V shall be a times $V_0 \times 2$. $V = 2aV_0$ ($a < 1$)
- ③ R_2 shall equal $R_1 \times b$. ($b < 1$) (1)

3-2 Formulas to calculate [R_B]

3-2-1 Following formula can be established from balanced condition.

$$V_1 \left[\frac{1}{R_1} + \frac{1}{R_B} \right] = V_2 \left[\frac{1}{R_2} + \frac{1}{R_B} \right] \quad (2)$$

3-2-2 Following formula can be established from preconditions.

$$V_2 \leq V_0 \quad (3)$$

$$V_1 = V - V_2 \quad (4)$$

$$= 2aV_0 - V_2 \quad (4')$$

3-2-3 Put formulas (1), (3) and (4') in formula (2).

$$(2aV_0 - V_2) \left[\frac{R_1 + R_B}{R_1 \times R_B} \right] = V_2 \left[\frac{bR_1 + R_B}{bR_1 \times R_B} \right]$$

$$2abV_0(R_1 + R_B) = V_2 \{b(R_1 + R_B) + bR_1 + R_B\}$$

$$2ab(R_1 + R_B) \leq 2bR_1 + (1 + b)R_B$$

Accordingly, balance resistance R shall be the following formula.

$$R_B \leq 2bR_1 \frac{(1-a)}{(2a-1) \times b - 1} \quad (5)$$

3-3 Calculation Example

Calculate the value of the balance resistance in the case of connecting two 400V 470 μ F (LC standard value : 1.88mA) capacitors in series.

$$R_1 = \frac{400(V)}{1.88(mA)} = 213(k\Omega)$$

If $a=0.8$, $400(V) \times 2 \times 0.8 = 640(V)$ as an impressed voltage.

If $b=2$, $R_2 = b R_1 = 426(k\Omega)$, $LC = 0.94(mA)$.

Balance resistance R_B will be.

$$R_B \leq 2 \times 2 \times 213(k\Omega) \frac{(1-0.8)}{(2 \times 0.8) \times 2 - 1} = 852(k\Omega)$$

4 Regarding Recovery Voltage

- After charging and then discharging the aluminum electrolytic capacitor, and further causing short-circuit to the terminals and leave them alone, the voltage between the two terminals will rise again after some interval. Voltage caused in such case is called recovery voltage. Following is the process that causes this phenomenon :

- When the voltage is impressed on a dielectric, electrical transformation will be caused inside the dielectric due to dielectric action, and electrification will occur in positive-negative opposite to the voltage impressed on the surface of the dielectric. This phenomenon is called polarization action.

- After the voltage is impressed with this polarization action, and if the terminals are discharged till the terminal voltage reaches 0 and are left open for a while, an electric potential will arise between the two terminals and thus causes recovery voltage.

- Recovery voltage comes to a peak around 10 to 20 days after the two terminals are left open, and then gradually declines. Recovery voltage has a tendency to become bigger as the component (stand-alone base type) becomes bigger.

- If the two terminals are short-circuited after the recovery voltage is generated, a spark may scare the workers working in the assembly line, and may put low-voltage driven components (CPU, memory, etc.) in danger of being destroyed. Measures to prevent this is to discharge the accumulated electric charge with resistor of about 100 to 1k Ω before using, or ship out by making the terminals in short-circuit condition by covering them with an aluminum foil at the production stage. Please consult us for adequate procedures.

5 Electrode Foil Development Technology

5-1 Corrosion inhibition of cathode foil

Inactive treatment is implemented to ensure long life by inhibiting natural corrosion of the cathode foil. Fig. 3-1 shows its effects with values of the polarization resistance inversely proportional to the corrosion rate using the AC impedance method (FRA). This indicates that the cathode foil used in the High reliability capacitors has the polarization resistance higher than that of the conventional capacitors owing to corrosion inhibition.

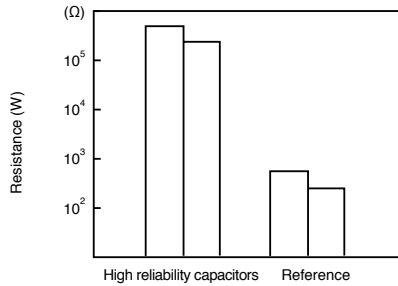

Fig. 3-1

5-2 Sealing material permeability of electrolyte

To ensure long life, a low permeable lactone solvent for the sealing material is used as the main solvent of the electrolyte of the High reliability capacitor. Fig. 3-2 shows the test results on the permeability obtained by changing the weight of the capacitors produced with different types of electrolytes at a high temperature.

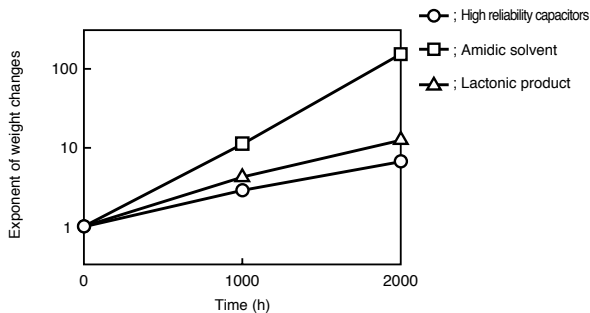

Fig. 3-2

5-3 Airtightness of sealing material

Since the electrolyte is stable for hours, the key element for capacitor's life is the sealing material. By optimizing the crosslinking density of the sealing material polymer, the sealing material of the High reliability capacitor attains its long life with electrolyte permeability less than that of the conventional capacitors.

Fig. 3-3 shows the test results on the airtightness of the sealing material obtained by changing the weight of the capacitors at a high temperature, producing capacitors with the conventional sealing material and improved one both containing the electrolyte used in the High reliability capacitor.

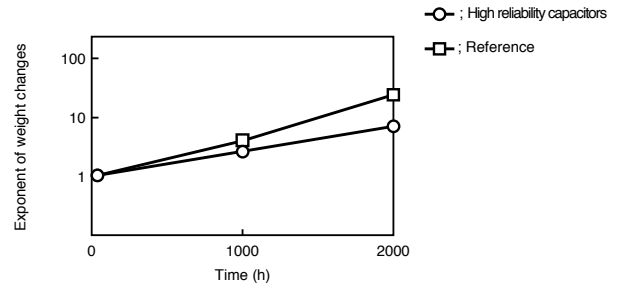

Fig. 3-3

5-4 Long-time stability of electrolyte

The electrolyte used in the High reliability capacitor is stable with low initial resistivity and small secular changes at a high temperature. Fig. 3-4 shows change in resistivity at 105°C.

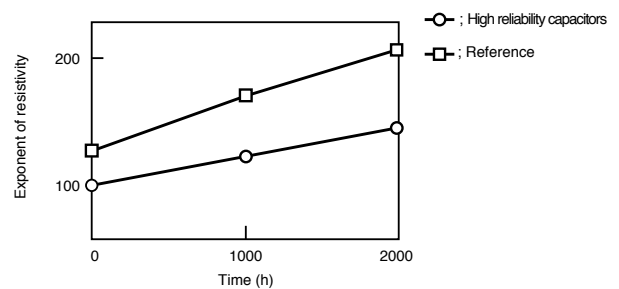

Fig. 3-4

5-5 Dielectric formation voltage and leakage current characteristics of anode foil

To increase the operating life by controlling the gas generation inside capacitor because of 1.5 to 2 times the rated voltage, while that of the previous capacitor is about 1.3 times the rated voltage.

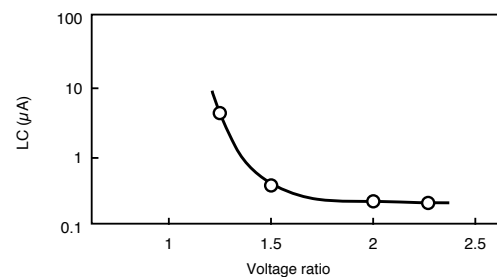

Fig. 3-5

5-6 Lowered ESR of Electrode Foil

To reduce the ESR of electrolytic capacitor, we have improved our chemical conversion technology for anode foil to develop lower ESR electrode foil compared to the conventional product as shown in Fig. 3-6

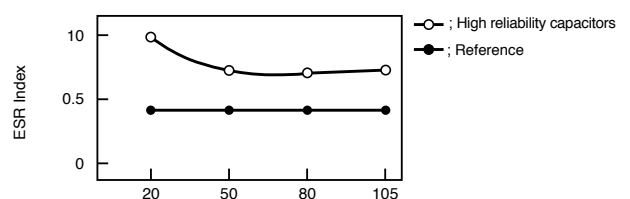
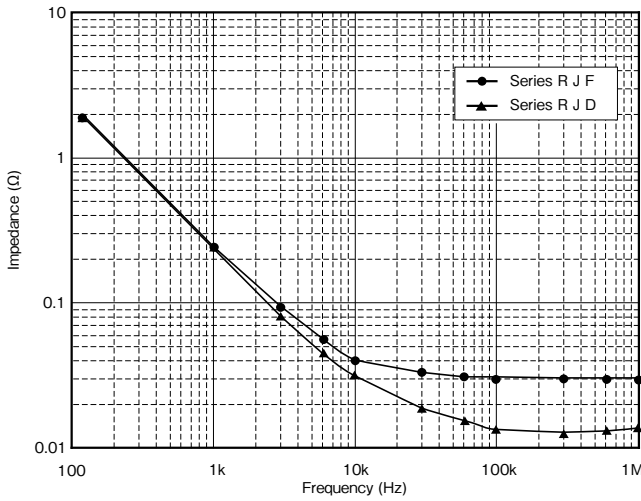

Fig. 3-6 ESR Index of Anode Foil

6. Electric Characteristics Data

6-1 Series RJF, RJB, RJD

Frequency characteristics at 20°C



| Performance \ Series | R J F | R J D |
|--------------------------------|---------|---------|
| Rated Voltage | 35V | 35V |
| Capacitance | 680μF | 680μF |
| Size (φ×L) | 12.5×20 | 12.5×20 |
| Impedance Spec. (20°C, 100kHz) | 0.017Ω | 0.038Ω |

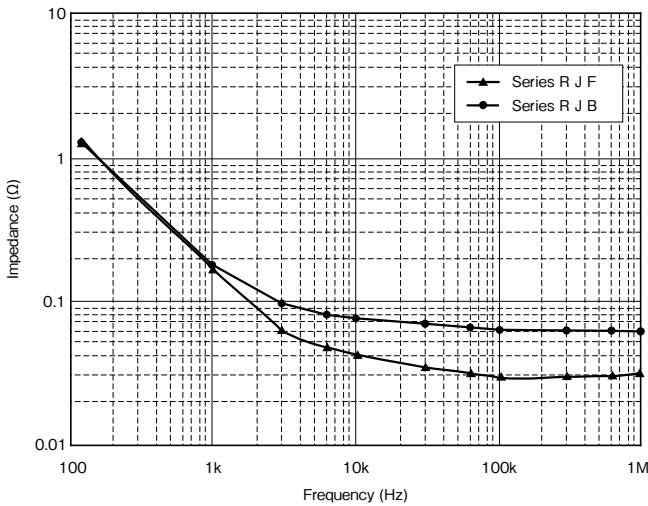

| Performance \ Series | R J F | R J B |
|--------------------------------|--------|--------|
| Rated Voltage | 10V | 10V |
| Capacitance | 1000μF | 1000μF |
| Size (φ×L) | 10×16 | 10×16 |
| Impedance Spec. (20°C, 100kHz) | 0.038Ω | 0.080Ω |

Frequency characteristics at 20°C, -10°C

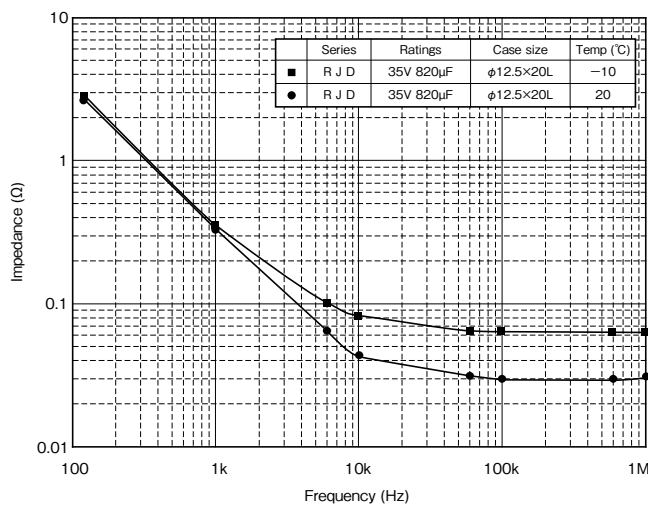

Endurance (Applied ripple current) at 105°C

Series R J D

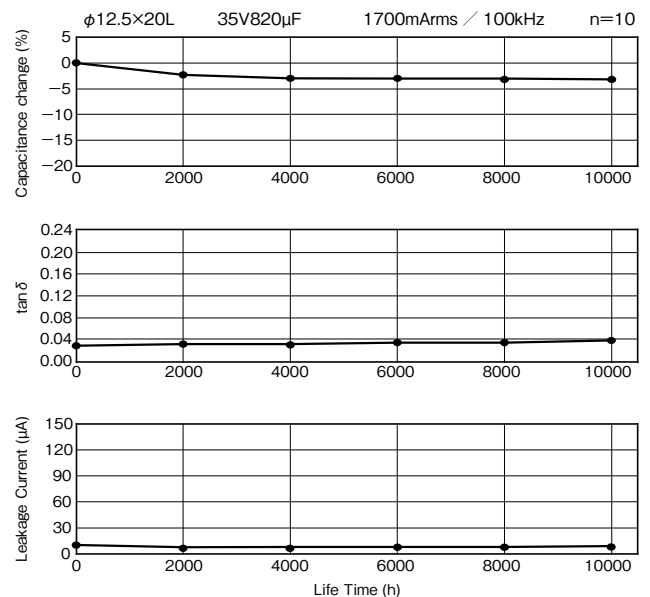

Notice : The measurement values are not guaranteed values, but measurements.

NOTE : Design, Specifications are subject to change without notice. It is recommended that you shall obtain technical specifications from ELNA to ensure that the component is suitable for your use.

6-2 Series RVD

Frequency characteristics at 20°C

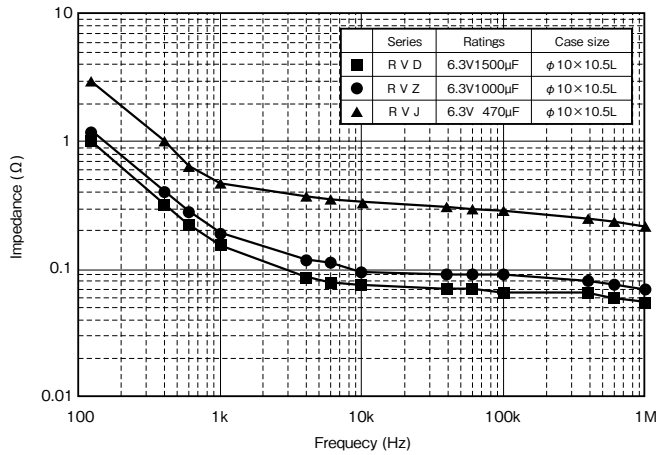

Frequency characteristics at 20°C, -40°C

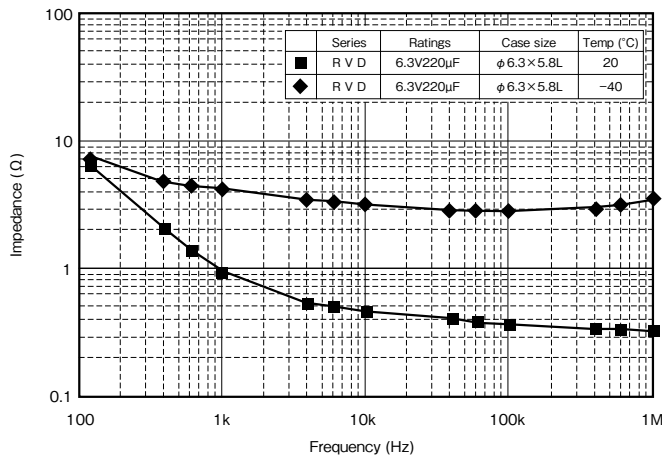

6-3 Series RKD

Endurance (Applied ripple current) at 125°C

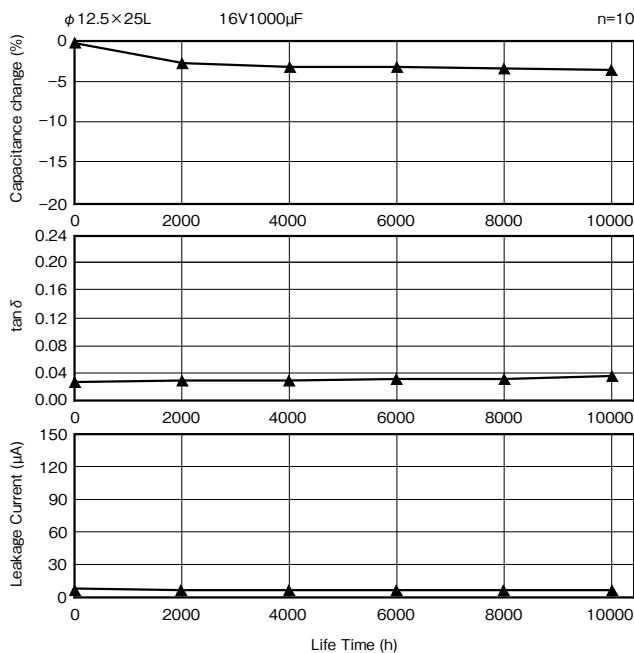

Endurance (Applied ripple current) at 105°C

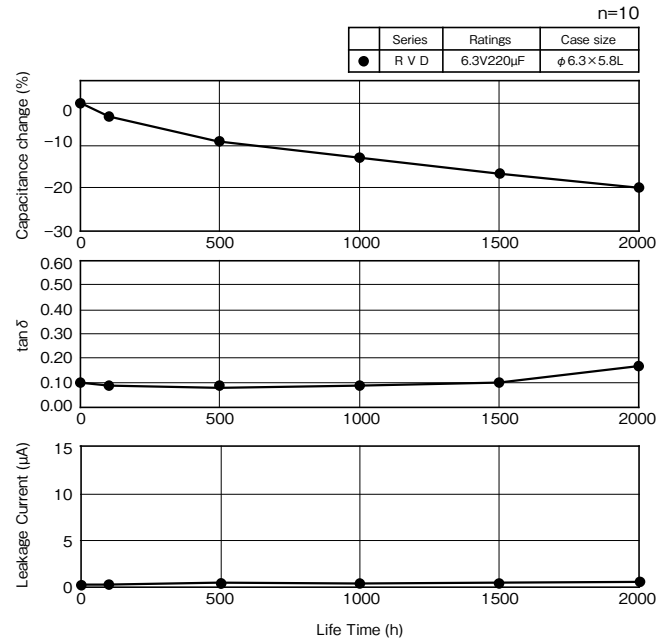

Temperature Characteristics

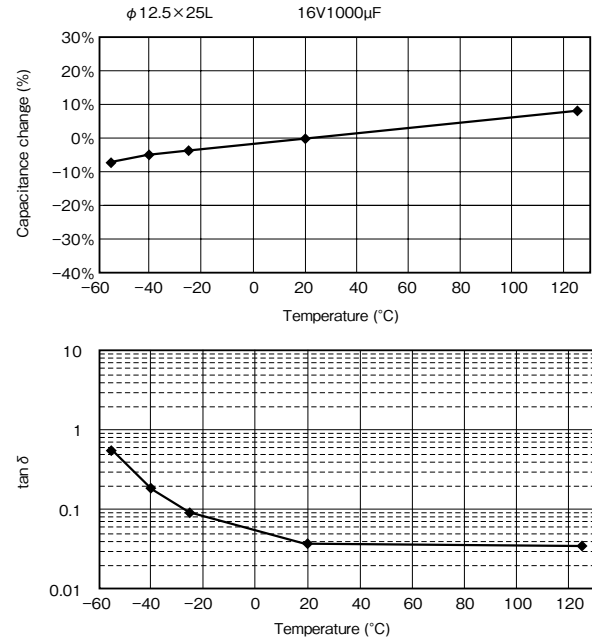

Notice : The measurement values are not guaranteed values, but measurements.

6-4 Series LAT • LAH

Temperature characteristics, Series LAT • LAH

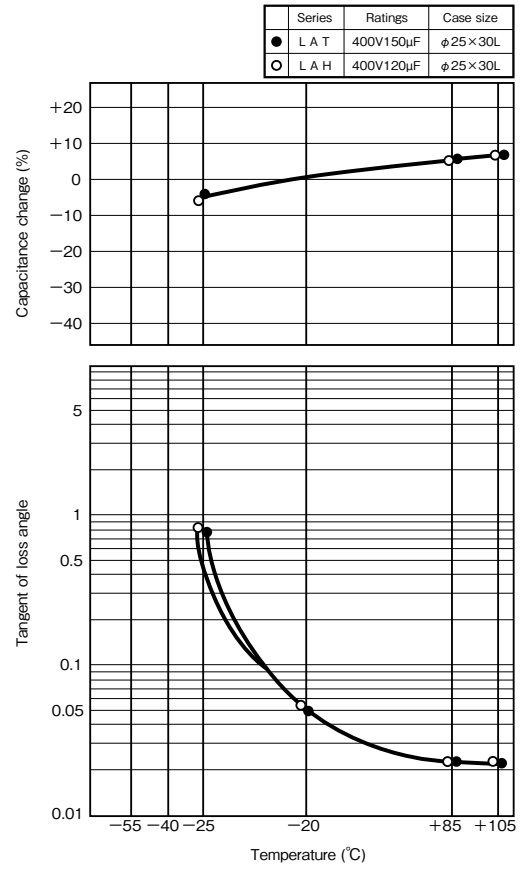
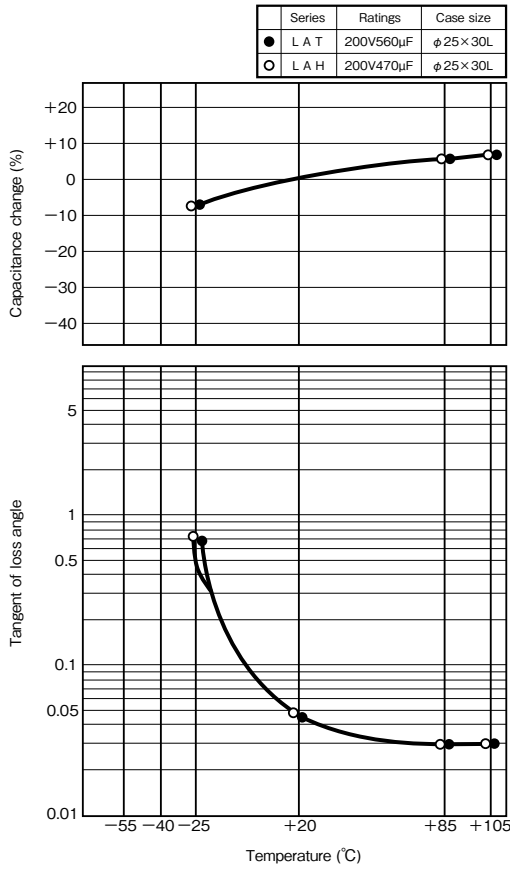

Endurance (Applied ripple current) at 105°C of Series LAT • LAH

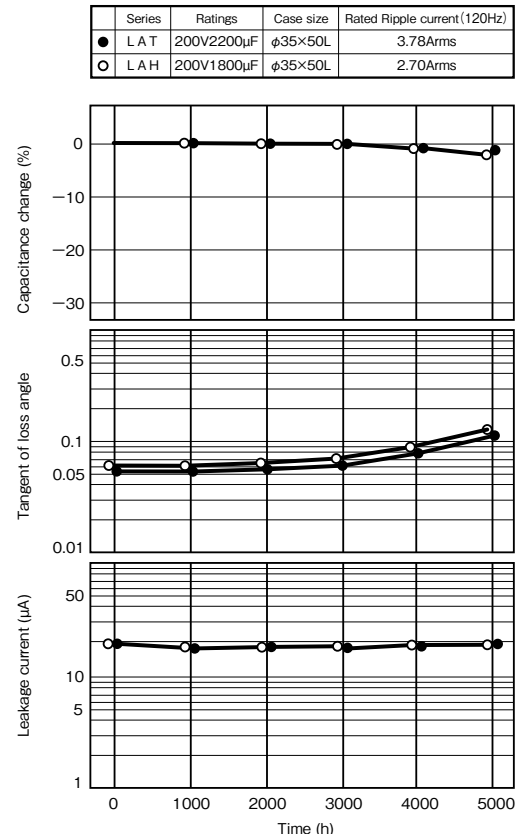
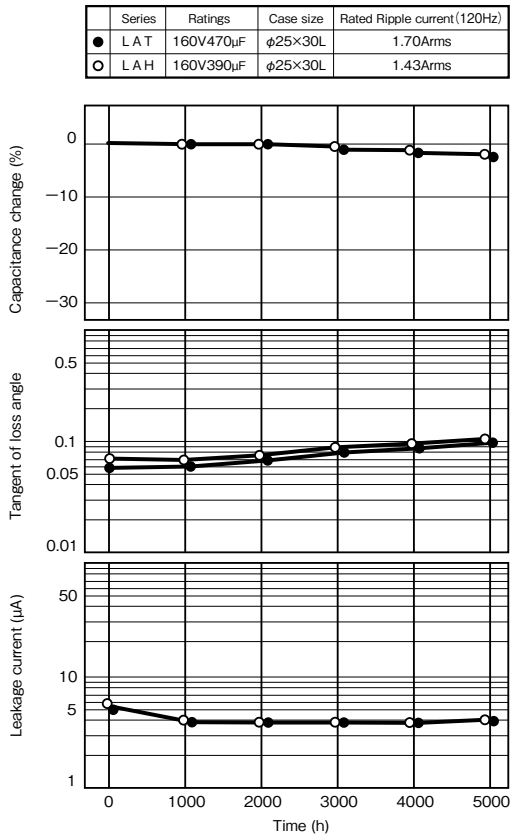

Notice : The measurement values are not guaranteed values, but measurements.

NOTE : Design, Specifications are subject to change without notice. It is recommended that you shall obtain technical specifications from ELNA to ensure that the component is suitable for your use.

6-5 Series LAX

Temperature characteristics, Series LAX

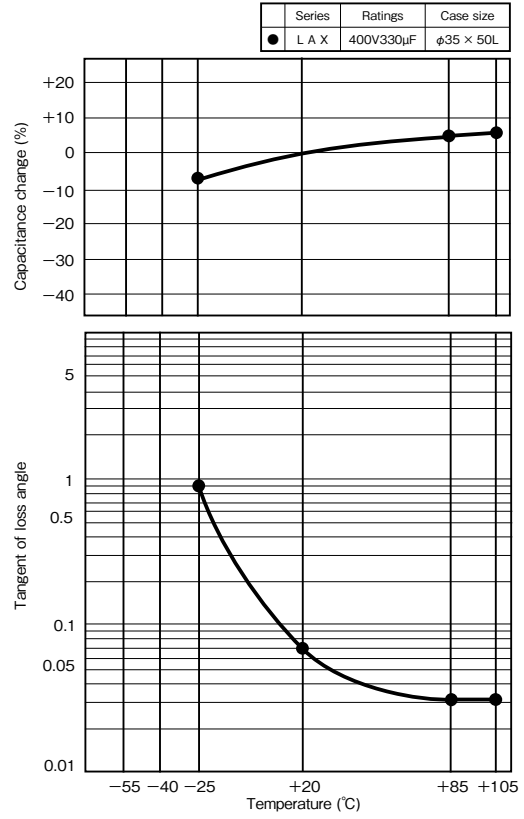
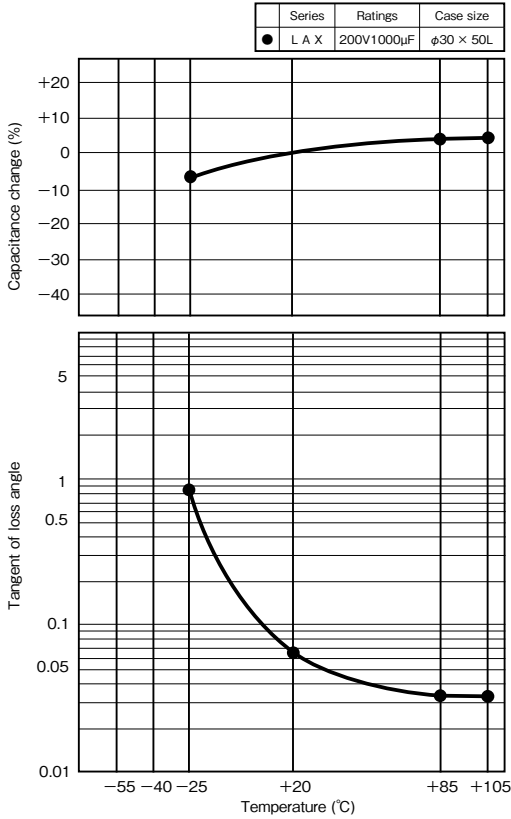

Endurance (Applied ripple current) at 105°C of Series LAX

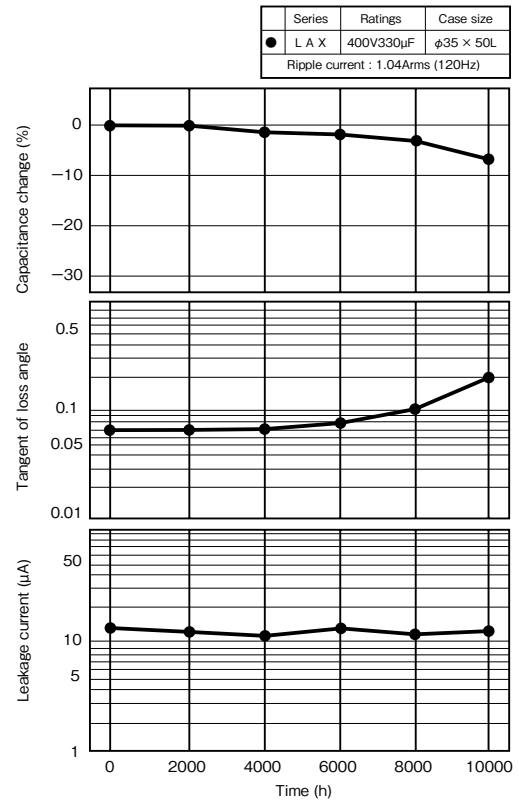
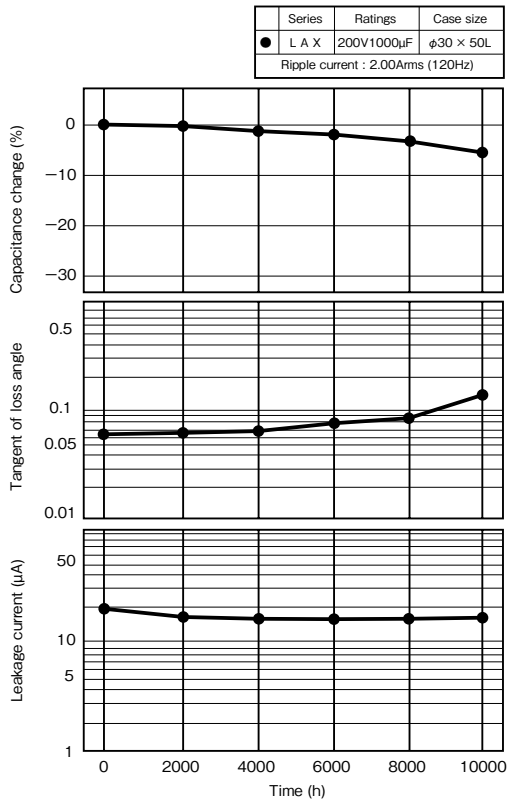

Notice : The measurement values are not guaranteed values, but measurements.

ELNA®

Electric Double Layer Capacitors “DYNACAP”, “POWERCAP”

List of Contents

| | |
|---|-----|
| 1. Type List and Systematized Classification for Electric Double Layer Capacitors | 188 |
| 2. Taping | 192 |
| 3. Cautions for Using Electric Double Layer Capacitors | 194 |
| 4. Specifications for Electric Double Layer Capacitors by Series | 196 |
| 5. Technical Note for Electric Double Layer Capacitors | 221 |
| 6. Presentation of Series and Parallel Connection Pack | 224 |
| 7. Technical data for Electric Double Layer Capacitors | 225 |



■ Type List for DYNACAP

★ : New series
☆ : Upgrade

| Category | Series | Category temp. range °C | | Max. operating voltage V.DC | Capacitance range F | Color of sleeve | Page | Applications | Remarks | |
|----------------------------|--|-------------------------|------|-----------------------------|---------------------|-----------------|--------|--|--|---|
| | | Max. | Min. | | | | | | | |
| For memory backup | Reflow soldering type | DVN | +70 | -25 | 5.5 | 0.047 to 0.33 | Brown | 196 | Ideal for backing up of RTC' s, momentary backup of a battery etc. | ☆ |
| | Reflow soldering type | DVL | +85 | -40 | 5.5 | 0.047 to 0.22 | Brown | 197 | | |
| | Standard type | DB | +70 | -25 | 5.5 | 0.047 to 1.5 | Indigo | 198 | Ideal for backing up of CMOS IC' s, microcomputers, RAM' s, RTC' s and the like used in VIDEO' s, tuners, TV sets, telephone sets, DVD and others. | |
| | Low profile Low ESR type | DBN | +70 | -25 | 5.5 | 0.047 to 1.5 | Indigo | 198 | | |
| | Low profile High temperature type | DBJ | +85 | -10 | 5.5 | 0.047 to 1 | Black | 199 | | |
| | Low profile Low ESR High temperature type | DBS | +85 | -25 | 3.6 | 0.047 to 1 | Black | 200 | | |
| | Miniaturized Standard type | DX | +70 | -25 | 5.5 | 0.047 to 1.5 | Indigo | 201 | | |
| | Miniaturized Low ESR type | DXN | +70 | -25 | 5.5 | 0.047 to 1.5 | Indigo | 202 | Ideal for backing up of CMOS IC' s, microcom-puters, RAM' s, RTC' s and the like used in VIDEO' s, tuners, TV sets, telephone sets, DVD, pager units, cameras, personal wireless items and others. | |
| | Miniaturized High temperature type | DXJ | +85 | -10 | 5.5 | 0.047 to 1 | Black | 203 | | |
| | Miniaturized Low ESR High temperature type | DXS | +85 | -25 | 3.6 | 0.047 to 1 | Black | 204 | | |
| | High voltage tolerance type | DK | +70 | -25 | 6.3 | 0.047 to 1 | Indigo | 205 | Ideal for backing up of Li-battery backed equipment such as cameras, VIDEO' s and telephone. | |
| | High temperature type | DH | +85 | -25 | 5.5 | 0.047 to 1 | Indigo | 206 | Ideal for backing up of controls, electronic rice cooking jars, home bakeries and others. | |
| | Wide temperature range type | DHL | +85 | -40 | 5.5 | 0.047 to 1 | Indigo | 207 | Ideal for backing up of CMOS IC' s, microcomputers, RAM' s, RTC' s for smart meter, outdoor equipment, auto motive and industrial. | |
| | High temperature long life type | DHC | +85 | -25 | 5.5 | 0.047 to 1 | Black | 208 | | |
| | Coin type | DC (614) | +70 | -25 | 2.5 | 0.2 | Silver | 209 | Ideal for backing up of pager, solar watches, solar calculators, solar remote control units, camaras and the like. | |
| DCK (614) | | +60 | -10 | 3.3 | 0.2 | | | | | |
| DC (621) | | +70 | -25 | 2.5 | 0.4 | | | | | |
| DCK (621) | | +60 | -10 | 3.3 | 0.4 | | | | | |
| Reflow soldering Coin type | DSK (414) | +70 | -10 | 3.3 | 0.07 | Silver | 210 | Mountable on board with best suited for mainly memory and time functions as well as memory backup for PDA and DSC. | | |
| | DS (614) | +70 | -25 | 2.5 | 0.2 | | | | | |
| | DSK (614) | +60 | -10 | 3.3 | 0.2 | | | | 211 | |
| | DS (621) | +70 | -25 | 2.5 | 0.33 | | | | | |
| | DSK (621) | +60 | -10 | 3.3 | 0.33 | | | | | |
| For power | Standard type | DZ | +70 | -25 | 2.5 / 2.7 | 1 to 200 | Black | 212 | Ideal for power supplies of LED displays, personal wireless items, backup for power supplies, and the storage battery of solar battery. | ☆ |
| | Large capacitance type | DZH | +60 | -25 | 2.5 | 22 to 300 | Black | | | ☆ |
| | High power type | DZN | +70 | -25 | 2.5 / 2.7 | 1 to 200 | Blue | 214 | Ideal for actuator of moters and electromagnetic coil drives. | ☆ |
| | High power Low temperature type | DU | +65 | -40 | 2.7 | 1 to 33 | Brown | 216 | Ideal for actuator of moters and electromagnetic coil drives. | ★ |
| | Low temperature type | DY | +70 | -40 | 2.5 | 1 to 40 | Brown | 217 | Ideal for power supplies of LED displays, personal wireless items, backup for power supplies, and the storage battery of solar battery. | ☆ |
| | Packed type | DZP | +70 | -25 | 5.0 | 0.47 to 4.7 | Blue | 218 | | ☆ |

■ Type List for POWERCAP

| Category | Series | Category temp. range °C | | Max. operating voltage V.DC | Capacitance range F | Color of sleeve | Page | Applications | Remarks | |
|------------|-----------------------------------|-------------------------|------|-----------------------------|---------------------|-----------------|-------|--------------|---|---|
| | | Max. | Min. | | | | | | | |
| For energy | Large capacitance High power type | DW | +65 | -40 | 2.7 | 3000 | Black | 219 | Ideal for boost charge, such as energy regeneration, and a large current discharge use. | ★ |
| | Large capacitance type | DP | +60 | -25 | 2.5 | 500 to 1500 | Black | 220 | Ideal for power supplies of LED displays, backup for power supplies, the storage battery of solar battery, and actuator of moters and electomagnetic coil drives. | |

NOTE : Design, Specifications are subject to change without notice. It is recommended that you shall obtain technical specifications from ELNA to ensure that the component is suitable for your use.

Systematized Classification of Electric Double Layer Capacitors

DYNACAP & POWERCAP

For memory backup

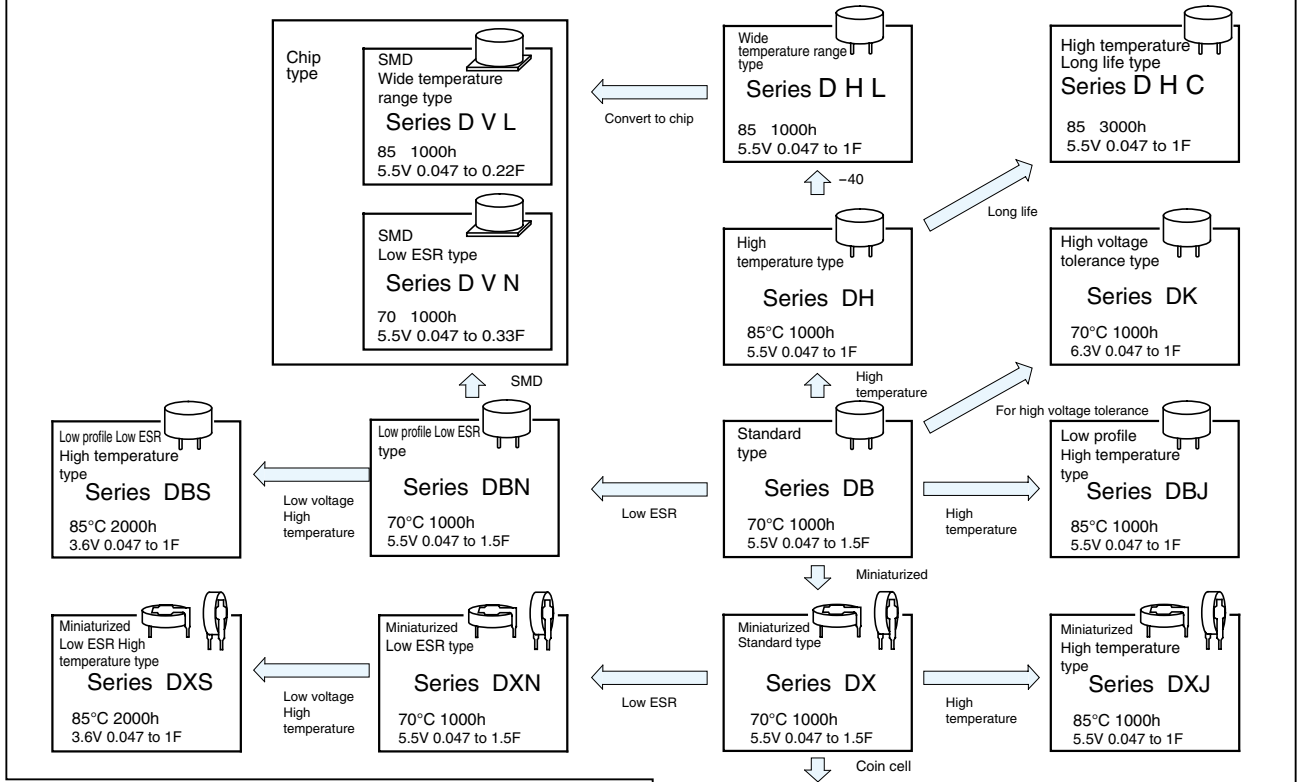

For power & energy

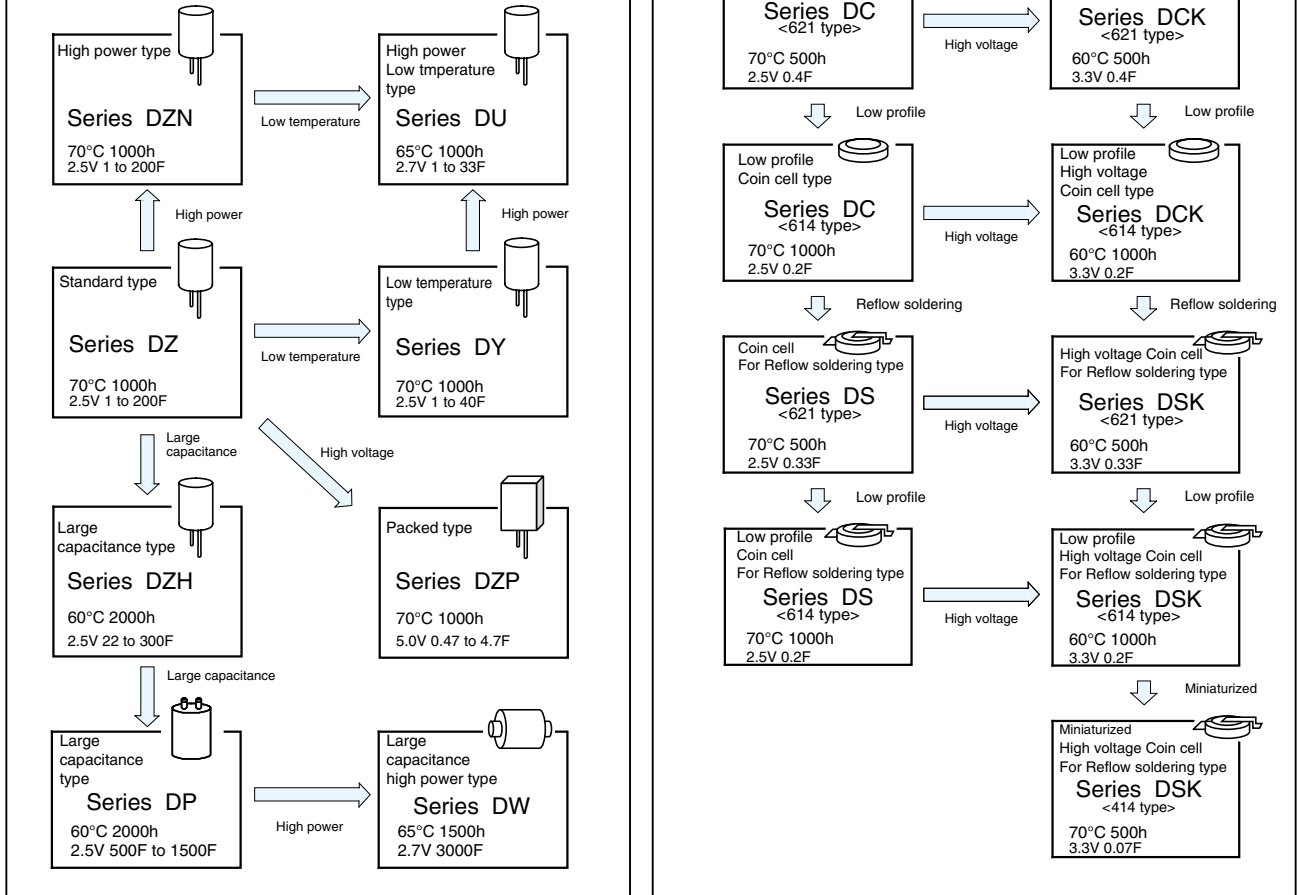

NOTE : Design, Specifications are subject to change without notice. It is recommended that you shall obtain technical specifications from ELNA to ensure that the component is suitable for your use.

■ Product Symbol System for Electric Double Layer Capacitors

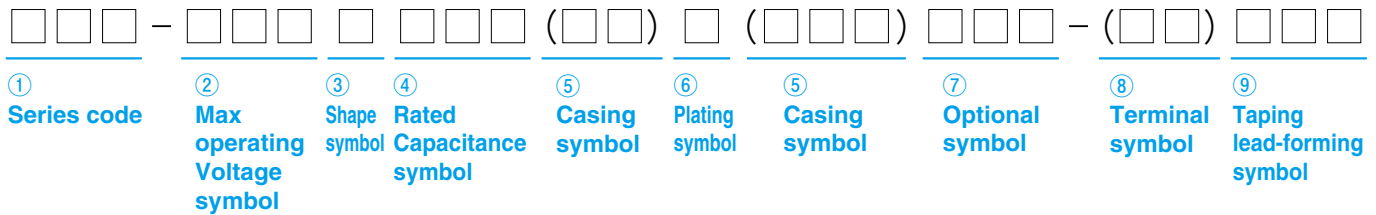

① Series code

Please refer to the page of each series.

② Max operating voltage symbol

Example

| Max. operating voltage (V) | Voltage symbol |
|----------------------------|----------------|
| 2.5 | 2R5 |
| 2.7 | 2R7 |
| 3.3 | 3R3 |
| 3.6 | 3R6 |
| 5.0 | 5 |
| 5.5 | 5R5 |
| 6.3 | 6R3 |

③ Shape symbol

Please refer to the page of each series.

④ Rated capacitance symbol

Example

| Capacitance (F) | Capacitance symbol | Capacitance (F) | Capacitance symbol |
|-----------------|--------------------|-----------------|--------------------|
| 0.047 | 473 | 10 | 106 |
| 0.07 | 703 | 15 | 156 |
| 0.1 | 104 | 20 | 206 |
| 0.2 | 204 | 22 | 226 |
| 0.22 | 224 | 25 | 256 |
| 0.33 | 334 | 30 | 306 |
| 0.4 | 404 | 33 | 336 |
| 0.47 | 474 | 40 | 406 |
| 0.68 | 684 | 50 | 506 |
| 0.9 | 904 | 100 | 107 |
| 1 | 105 | 200 | 207 |
| 1.5 | 155 | 300 | 307 |
| 2.7 | 275 | 500 | 507 |
| 3.3 | 335 | 600 | 607 |
| 4.7 | 475 | 1200 | 128 |
| 5.6 | 565 | 1500 | 158 |
| 6.8 | 685 | 3000 | 308 |

⑤ Casing symbol

Please refer to the page of each series.

⑥ Plating symbol

Example

| Symbol | Contents |
|--------|-----------------------------|
| U | Sn 100% plating (coin cell) |
| T | Sn 100% plating |

⑦ Optional symbol

Example

| Symbol | Contents |
|--------|-------------------|
| Q | Based on AEC-Q200 |
| M | Based on AEC-Q200 |

⑧ Terminal symbol

Please refer to the page of each series.

⑨ Taping, Lead-forming symbol

DZ,DZH,DZN,DY,DU : Write down one of the forming symbols given on page 14 to 17 for taping and lead-forming capacitors.

DVN,DVL,DSK : Write down one of the forming symbols given on page 192 for taping capacitors.

When taping or lead-forming is not necessary, leave the boxes blank.

Recommended soldering method (series DS, DSK, DVN, DVL)

Reflow soldering conditions.

Profile

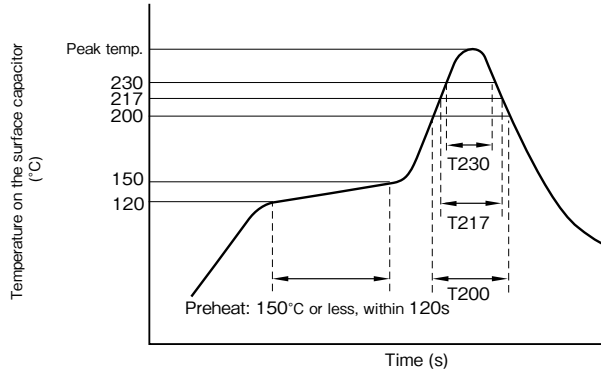

T200 : Duration while capacitor head temperature exceeds 200°C (s)
 T217 : Duration while capacitor head temperature exceeds 217°C (s)
 T230 : Duration while capacitor head temperature exceeds 230°C (s)
 The measurement temperature point is the case top

| Series | Size | Peak temp. (5s Max) | T230 | T217 | T200 | Times |
|------------|--------------|---------------------|------------|------------|------------|-------|
| DS DSK | φ4.8 to φ6.8 | 250°C Max | Within 20s | Within 30s | Within 40s | 2 Max |
| DVN DVL | φ12.5 | 260°C Max | Within 20s | Within 30s | Within 50s | 2 Max |

Attention : Carry out soldering work at low temperature and in the shortest time within above conditions.
 Do NOT reflow solder, when cell voltage is above 0.3V.

*Please consult with us about reflow soldering conditions other than the above.

Taping

Carrier tape dimensions (Series DS, DSK) polarity L

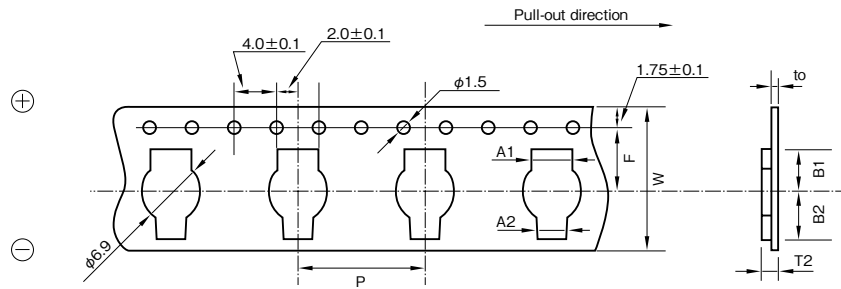

(Unit : mm)

| Outside size | W | P | F | A1 | A2 | B1 | B2 | T2 | to | φD |
|-------------------------------------|--------|------|------|-----|-----|-----|-----|------|-----|-----|
| φ6.8×1.4 to 2.1L | 24±0.2 | 12.0 | 11.5 | 4.4 | 3.4 | 5.9 | 6.5 | 3.2 | 0.3 | 6.9 |
| φ4.8×1.4L (Terminal shaped : HL) | 16±0.2 | 8.0 | 7.5 | 2.4 | 3.6 | 5.0 | 5.1 | 2.45 | 0.3 | 4.9 |
| φ4.8×1.4L (Terminal shaped : HR) | ↑ | ↑ | ↑ | 3.6 | 2.4 | 5.1 | 5.0 | ↑ | ↑ | ↑ |

Reel dimensions

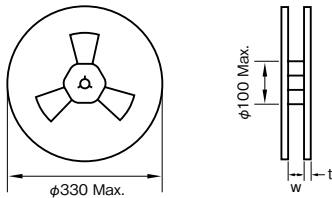

(Unit : mm)

| Outside size | W | t |
|------------------|----|---|
| φ6.8×1.4 to 2.1L | 26 | 3 |
| φ4.8×1.4L | 18 | 3 |

Packing quantity

| Outside size | Quantity |
|--------------|----------------------|
| φ6.8×2.1L | 1500PCS. |
| φ6.8×1.4L | 1500PCS. to 2000PCS. |
| φ4.8×1.4L | 2000PCS. |

Carrier tape dimensions (Series DVN, DVL) polarity R

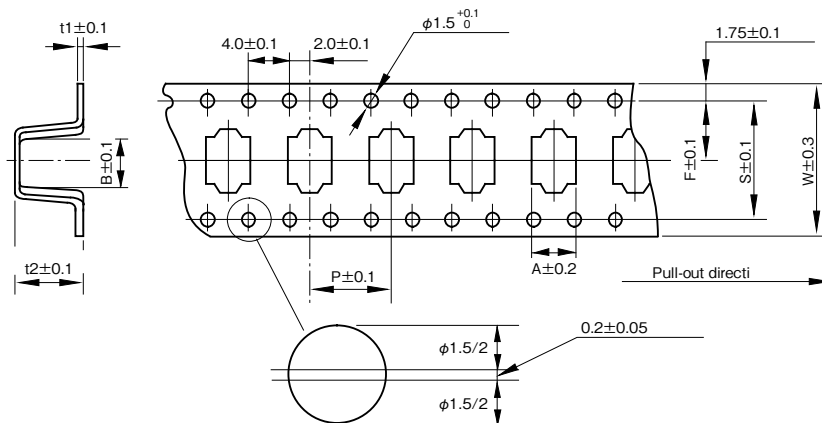

(Unit : mm)

| Outside size | W | A | B | P | t2 | F | t1 | S |
|--------------|----|------|------|----|-----|------|-----|------|
| φ12.5×10.5L | 32 | 13.4 | 13.4 | 24 | 11 | 14.2 | 0.5 | 28.4 |
| φ12.5× 8.5L | 32 | 13.4 | 13.4 | 24 | 9.5 | 14.2 | 0.5 | 28.4 |

Reel dimensions

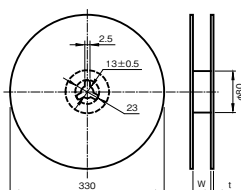

(Unit : mm)

| Outside size | W | t |
|--------------|----|---|
| φ12.5×10.5L | 34 | 3 |
| φ12.5× 8.5L | 34 | 3 |

Packing quantity

| Outside size | Quantity |
|--------------|----------|
| φ12.5×10.5L | 250pcs. |
| φ12.5× 8.5L | 300pcs. |

NOTE : Design, Specifications are subject to change without notice.
It is recommended that you shall obtain technical specifications from ELNA to ensure that the component is suitable for your use.

■ **Standard packing specification of Coin cell type**

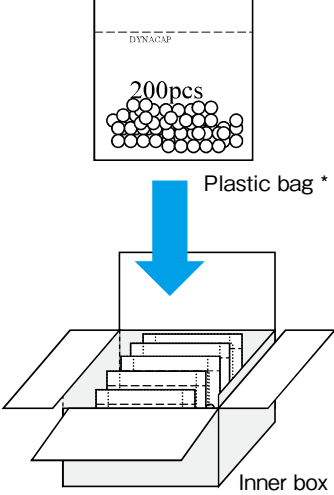
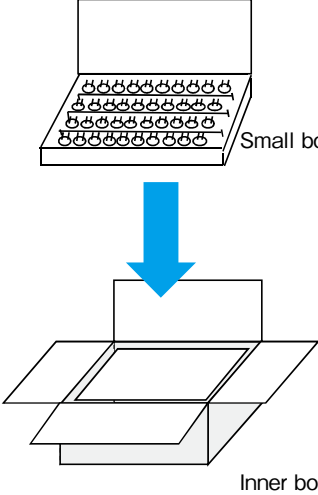
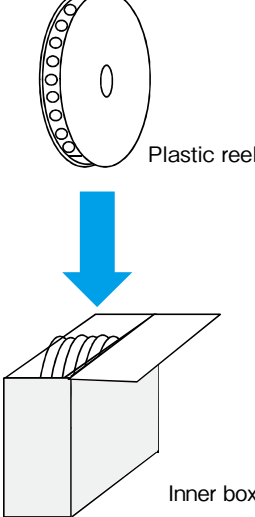
| | | | |
|-----------------------------|--|---|---|
| <p>Series</p> | <ul style="list-style-type: none"> • DC, DCK (614, 621) • DX, DXJ, DXN, DXS • DB, DBN, DBJ, DBS, DK, DH, DHL, DHC (φ13.5) | <ul style="list-style-type: none"> • DB, DBN, DBJ, DBS, DK, DH, DHL, DHC (φ21.5) | <ul style="list-style-type: none"> • DSK (414, 614, 621) • DVN, DVL |
| <p>Packing style</p> |  <p>200 pcs DYNACAP Plastic bag * Inner box</p> <p>* DC, DCK : Vacuum packing</p> |  <p>Small box Inner box</p> |  <p>Plastic reel Inner box</p> |

■ **Standard packing specification of large type**

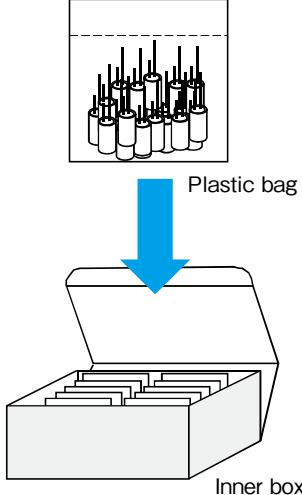
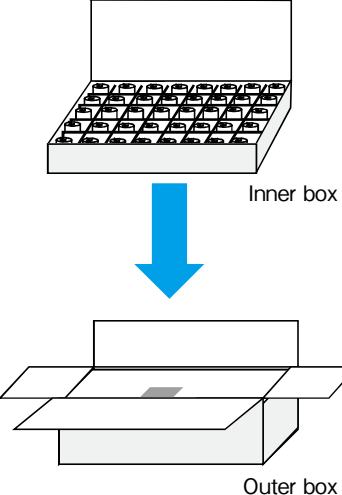
| | | |
|-----------------------------|--|---|
| <p>Series</p> | <ul style="list-style-type: none"> • DU, DY, DZ, DZN, DZH (φ6.3 to φ18) • DZP | <ul style="list-style-type: none"> • DZ, DZN, DZH (φ22 or more) |
| <p>Packing style</p> |  <p>Plastic bag Inner box</p> |  <p>Inner box Outer box</p> |

Please inquire for details.

Cautions for Using Electric Double Layer Capacitors (DYNACAP , POWERCAP)

■ Usage

1. Electric double layer capacitors (EDLC) use a conductive organic electrolyte.

The use at excessive mounting temperature or exceeding the upper category temperature can cause the electrolyte to leak. Especially, coin and multilayer coin types for the memory backup excluding the DZ, DZH, DZN and DP series use a low elastic plastic as the sealant in the cell construction like coin batteries; therefore, avoid using such capacitors in the Vicinity of automotive equipment with steep temperature change, and heating element such as motor, relay, transformer, power IC, etc. because of the risk of leakage of electrolyte.

2. Since EDLC is polarized, do not apply a reversed voltage.

EDLC is polarized. If a reversed voltage is applied for a long time, the leakage current will increase abruptly, which may cause a decrease in the capacity, an increase in the internal resistance, and causing leakage or damage to the product in some cases.

3. Do not apply any voltage higher than the operating maximum voltage (this means the surge voltage in the case of short-time charge).

If an overvoltage is applied to the product, the leakage current will increase abruptly and the product will become overheated, which may cause a decrease in the capacity, an increase in the internal resistance, and causing leakage or damage to the product in some cases.

4. Do not use smoothing a power supply (for absorbing its ripple).

Since the internal resistance of EDLC is high, the product will be overheated if it is used for smoothing a power supply (for absorbing its ripple), which may cause a decrease in the capacity, an increase in the internal resistance, and causing leakage or damage to the product in some cases .

5. Do not use in a circuit where quick charge and discharge are repeated Very often.

In a circuit where quick charge and discharge are repeated very often , the product will become overheated, which may cause a decrease in the capacity, an increase in the internal resistance, and causing leakage or damage to the product in some cases.

Reduce the charge and discharge currents while selecting a product with low internal resistance, and make sure that the product surface temperature does not rise.

6. EDLC life depends heavily on the ambient temperature.

①The lifetime of EDLC is seriously affected by change in ambient temperature. If the temperature is lowered by 10°C, the lifetime will be approximately doubled. Therefore, the product should be used at a temperature lower than the guaranteed maximum value for maximum life.

②If the capacitor is used at a temperature exceeding its maximum guaranteed temperature, not only is its life shortened, but increased vapor

pressure of electrolyte or electrochemical reactions may increase the internal pressure, and causing leakage or damage to the product in some cases.

7. Note that a voltage drop In EDLC occurs during backup.

In a case where discharge current is large, or a large current flows instantaneously, an electric double layer capacitor may not operate at the start of discharge because of a large voltage drop (IR drop) caused by the product with the DC internal resistance.

Please consult us for a large discharge current (in the case of other series except DZ, DZH, DZN and DP series: when larger than $1 \text{ (mA)} = 1 \times C \text{ (F)}$) as the internal resistance varies by each series (Recommendation discharge current: less than 1 mA/F at 20°C)

8. Do not use the product in an ambient atmosphere containing waterdrops (condensation) or toxic gases.

Although EDLC is sealed, water droplets or toxic gases may do degradation characteristics, a leakage and corrode the lead wires and the case, which may cause a breaking of the wires.

Avoid abrupt temperature changes, which may cause water droplets, resulting in product deterioration and electrolyte leakage.

9. Contact us before connecting the products in series.

A series connection will cause imbalance in the voltage, charged to the capacitors and an overvoltage may be charged to one or more them. This may cause a decrease in the capacity, an increase in the internal resistance and causing leakage or damage to the product in some cases. When using series connection for several capacitors, please derate the applied voltage from the operating maximum voltage or use balancing circuits (bleeder resistor, etc.) to compensate for the imbalance in the applied voltage for each capacitor. Moreover, please ensure the arrangement does not cause temperature fluctuation between capacitors.

10. About vibration.

A terminal blank, a terminal bend, and a crease may occur by adding too much vibration to a capacitor.

Moreover, depending on the case, an EDLC may do degradation of the characteristic, breakage, and a leakage.

When you become too much vibration, please contact us.

11. When used on a double sided printed circuit board, do not overlap the wiring patterns on the mounted part.

A short circuit may be created by certain wiring conditions. Should the electrolyte leaks, the circuit pattern may cause a short circuit, resulting in tracking or migration.

12. Do not keep In high temperature and high humidity atmospheres.

①Avoid high temperature or high humidity or direct rays when storing capacitors.

②Keep the product in a place where the temperature is 5°C to 30°C and the humidity is lower than 60%. Avoid an abrupt temperature change, which may cause condensation or deterioration of the product or liquid leakage.

③Do not store EDLC at a place where there is a possibility that they may get water, salt or oil spill.

④Do not store EDLC at place where the air contains dense hazardous gas (hydrogen sulfide, sulfurous acid, nitrous acid, chlorine ammonia, etc.).

⑤Do not store EDLC at a place where it gets ultraviolet ray or radioactive ray.

13. Capacitors fitted with a relief valve

①The relief valve is provided with a valve function with part of the case made thin to avoid explosion by increased internal pressure when the capacitor is under abnormal load such as overvoltage or reverse voltage. After activation of the relief valve, the capacitor must be replaced as it does not restore.

②For the capacitors with a case relief valve (series DZ,DZH,DZN,DZP,DU,DY), provide a void on the top of the relief valve so as not to hamper its activation. Make a void of 2 mm or more for the product of $\phi 18$ or less in diameter, and a void of 3 mm or more for the product of $\phi 20$ to $\phi 35$ mm in diameter on the top.

14. Use at a high altitude

The use of capacitors at high altitudes such as on an airplane causes a large difference between the internal pressure of the capacitors and the atmospheric pressure.

However, there is no problem in use under atmospheric pressure up to about an altitude of 10,000 meters.

If the condition is severe like space, please contact us.

■ Mounting

1. Do not overheat when soldered.

Depending on the type and size of the board, the product may be subjected to overheat, leading to loss of airtightness. This may greatly shorten the product life or cause liquid leakage.

In case of a 1.6mm-thick and single side printed board. for example, keep the following soldering conditions: temperature lower than 260°C, time shorter than 5 seconds.

When a board thinner than 1.6 mm or multi-layer printed board is used, contact us.

In the case of hand soldering, the iron tip temperature is lower than 360°C, time is shorter than 3 seconds.

The coin types and multilayer coin types excluding the DZ and reflow-compatible coin types use polypropylene as the packing material for sealing and therefore susceptible to excessive heat. Note that the component body temperature shall be controlled so as not to exceed 90°C including preheating.

2. When soldering the capacitor to the wiring board, do not attach the body of the capacitor to the circuit board.

If the body of the capacitor is attached directly to the circuit board, the flux or solder can blow through the through holes in the circuit board, negatively

impacting the capacitor.

Moreover, the heat influence at the time of soldering can be reduced by floating the body.

3. Contact us when cleaning is necessary after soldering.

Certain types of solvents are not compatible and may cause damage.

4. Contact us when the product is attached by adhesive bonding.

Certain types of adhesives are not compatible.

Paste bond partially between the product and the board so that the product will not adhere completely to the board.

Do not raise the temperature over the guaranteed value while the bond is hardening.

5. Heating conditions of adhesive curing oven

During heating of the adhesive curing oven, application of excessive heat may significantly shorten the product life or cause liquid leakage. Control the body temperature so as not to exceed 90°C during work while setting the allowable atmospheric temperature below 110°C, and allowable heating time within 30 seconds.

For the heating conditions deviating from the above, consult with us providing your temperature profile conditions.

6. Be careful not to apply an excessive force to the capacitor body, terminals or lead wires.

①Mount the capacitor while making sure that the terminal spacing of the capacitor and the spacing of the holes in the printed wiring board are aligned.

②If the capacitor body is subjected to stress such as grabbing, falling, bend, pushing or twisting after mounted, its terminals may come off, leading to open, short or liquid leakage.

■ Other cautions

1. Emergency procedures

If the EDLC overheats or starts to smell, immediately switch off the units main power supply to stop operation.

Keep your face and hands away from the EDLC, since the temperature may be high enough to cause the EDLC to ignite and burn.

2. Periodical inspections should be established for the EDLC used in industrial appliances.

The following items should be checked:

①Appearance : Check if there is leakage.

②Electronic performance : Check the leakage current, the electrostatic, the internal resistance and other items described in the catalog or the product specifications.

3. Disposing of EDLC

①Punch a hole or crush the EDLC (to prevent explosion) before incineration at approved facility.

②If they are not to be incinerated, bring them to a professional industrial waste disposal company.

4. Other notes

Please refer to the following literature for anything not described in the product specifications or the catalog. (Technical Report of Japan Electronics and Information Technology Industries Association #EIAJ RCR-2370B "Guideline of notabilia for fixed electric double layer capacitors")

5.5V SMD, Low Resistance Capacitors

GREEN CAP

70°C

- Size : $\phi 12.5 \times 8.5$ mm, compatible with surface mounting and low ESR.
- Unlike batteries, safe and high reliability without containing active and hazardous substance.
- Unlike batteries, excellent charge and discharge characteristics with no chemical reactions.
- Responds to temperature 260°C during the reflow peek.



Marking color : White print on an brown sleeve

Convert to chip



Specifications

| Item | Performance | | | | |
|---|---|---|-----|------|------|
| Category temperature range (°C) | - 25 to +70 | | | | |
| Tolerance at rated capacitance (%) | - 20 to +80 | | | | |
| Internal resistance at 1 kHz | Rated capacitance (F) | 0.047 | 0.1 | 0.22 | 0.33 |
| | Internal resistance (Ω Max.) | 30 | 30 | 30 | 30 |
| Characteristics at high and low temperature | Percentage of capacitance change | Within $\pm 30\%$ of the value at 20°C | | | |
| | Internal resistance | Less than five times of the value at 20°C | | | |
| Endurance (70°C) | Test time | 1000 hours | | | |
| | Percentage of capacitance change | Within $\pm 30\%$ of the initial measured value | | | |
| | Internal resistance | Less than four times of the initial specified value | | | |
| Shelf life (70°C) | Test time : 1000 hours ; Same as endurance. | | | | |
| Applicable standards | Conforms to JIS C5160-1 2009 (IEC 62391-1 2006) | | | | |

Outline Drawing

Unit : mm

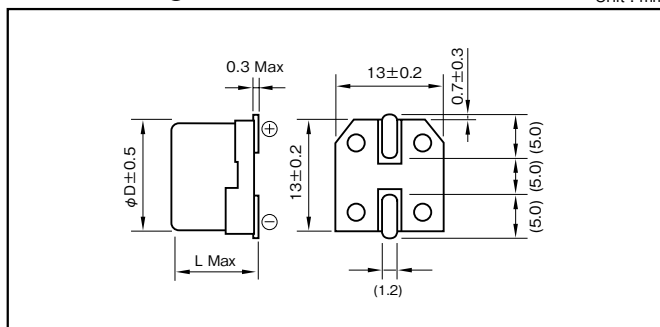

Recommended land pattern size

Unit : mm

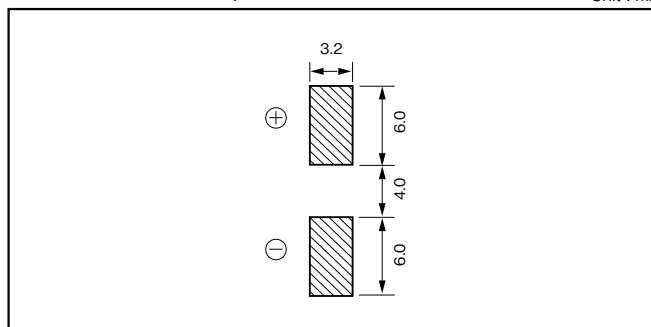

Part numbering system (example : 5.5V0.1F)

| | | | | | | | |
|-------------|---|-------------------------------|---------------|--------------------------|---|---|---------------|
| DVN | — | 5R5 | D | 104 | T | — | R5 |
| Series code | | Max. operating voltage symbol | Terminal code | Rated capacitance symbol | | | Taping symbol |

Part number is refer to following table.

Standard Ratings

| Max. operating voltage (V) | Rated capacitance (F) | ELNA Parts No. | $\phi D \times L$ (mm) |
|----------------------------|-----------------------|-----------------|------------------------|
| 5.5 | 0.047 | DVN-5R5D473T-R5 | 12.5 × 8.5 |
| 5.5 | 0.1 | DVN-5R5D104T-R5 | 12.5 × 8.5 |
| 5.5 | 0.22 | DVN-5R5D224T-R5 | 12.5 × 8.5 |
| 5.5 | 0.33 | DVN-5R5D334T-R5 | 12.5 × 8.5 |

*soldering conditions are described on page 191.

5.5V SMD, Wide Temperature range Capacitors

GREEN CAP

85°C

- Size : $\phi 12.5 \times 10.5$ mm, compatible with surface mounting.
- Wide temperature range (−40 to 85°C), Low ESR.
- Unlike batteries, safe and high reliability without containing active and hazardous substance.
- Unlike batteries, excellent charge and discharge characteristics with no chemical reactions.
- Responds to temperature 260°C during the reflow peak.



Marking color : White print on an brown sleeve

Convert to chip



Specifications

| Item | Performance | | | |
|---|---|--|-----|------|
| Category temperature range (°C) | − 40 to +85 | | | |
| Tolerance at rated capacitance (%) | − 20 to +80 | | | |
| Internal resistance at 1 kHz | Rated capacitance (F) | 0.047 | 0.1 | 0.22 |
| | Internal resistance (Ω Max.) | 45 | 45 | 45 |
| Characteristics at high and low temperature | Percentage of capacitance change | Within $\pm 30\%$ of the value at 20°C | | |
| | Internal resistance | −40°C : Less than seven times of the value at 20°C 85°C : Less than five times of the value at 20°C | | |
| Endurance (85°C) | Test time | 1000 hours | | |
| | Percentage of capacitance change | Within $\pm 30\%$ of the initial measured value | | |
| | Internal resistance | Less than four times of the initial specified value | | |
| Shelf life (85°C) | Test time : 1000 hours ; Same as endurance. | | | |
| Applicable standards | Conforms to JIS C5160-1 2009 (IEC 62391-1 2006) | | | |

Outline Drawing

Unit : mm

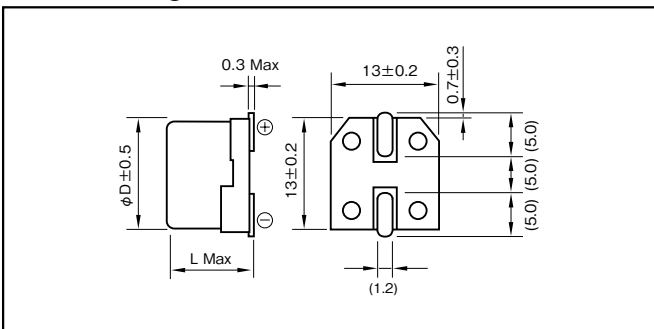

Recommended land pattern size

Unit : mm

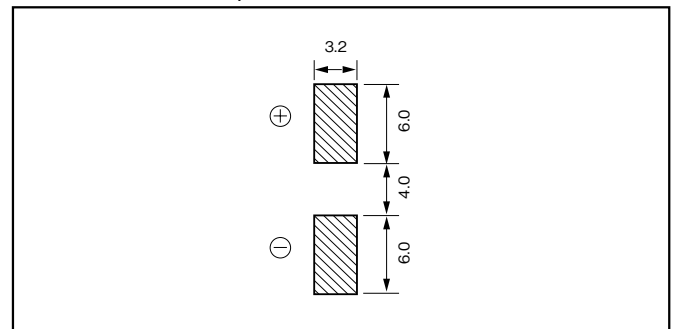

Part numbering system (example : 5.5V0.1F)

| | | | | | | | |
|-------------|---|-------------------------------|---------------|--------------------------|---|---|---------------|
| DVL | — | 5R5 | D | 104 | T | — | R5 |
| Series code | | Max. operating voltage symbol | Terminal code | Rated capacitance symbol | | | Taping symbol |

Part number is refer to following table.

Standard Ratings

| Max. operating voltage (V) | Rated capacitance (F) | ELNA Parts No. | $\phi D \times L$ (mm) |
|----------------------------|-----------------------|-----------------|------------------------|
| 5.5 | 0.047 | DVL-5R5D473T-R5 | 12.5 × 10.5 |
| 5.5 | 0.1 | DVL-5R5D104T-R5 | 12.5 × 10.5 |
| 5.5 | 0.22 | DVL-5R5D224T-R5 | 12.5 × 10.5 |

*soldering conditions are described on page 191.

5.5V Standard Capacitors Series DB

GREEN CAP

70°C

- Small-sized, large capacity, excellent voltage holding.
- For all ratings, uniform 5mm pitch of terminal spacing.
- Wider temperature range (-25 to +70°C) than battery.
- $\phi 21.5 \times 7.5L$ size can encase up to 1.5F.
- Ideal for backing up of CMOS's, IC's, microcomputers, RAM's, RTC's and the like used in Video's, tuners, TV sets, telephone sets and others.

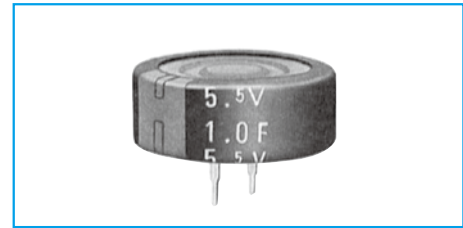

Marking color : White print on an indigo sleeve

Specifications

| Item | Performance | | | | | | | | |
|---|---|--|-----|------|------|--------------------|--------------------|----|-----|
| Category temperature range (°C) | -25 to +70 | | | | | | | | |
| Tolerance at rated capacitance (%) | -20 to +80 | | | | | | | | |
| Internal resistance at 1 kHz | Rated capacitance (F) | 0.047 | 0.1 | 0.22 | 0.33 | 0.47 | 0.47 | 1 | 1.5 |
| | Internal resistance (Ω Max.) | 120 | 75 | 75 | 75 | 75 ($\phi 13.5$) | 30 ($\phi 21.5$) | 30 | 30 |
| Characteristics at high and low temperature | Percentage of capacitance change | Within $\pm 30\%$ of the value at 20°C | | | | | | | |
| | Internal resistance | Less than five times of the value at 20°C | | | | | | | |
| Endurance (70°C) | Test time | 1000 hours | | | | | | | |
| | Percentage of capacitance change | Within $\pm 30\%$ of the initial measured value | | | | | | | |
| | Internal resistance | Within four times of the initial specified value | | | | | | | |
| Shelf life (70°C) | Test time : 1000 hours ; Same as endurance. | | | | | | | | |
| Applicable standards | Conforms to JIS C5160-1 2009 (IEC 62391-1 2006) | | | | | | | | |

Outline Drawing

Unit : mm

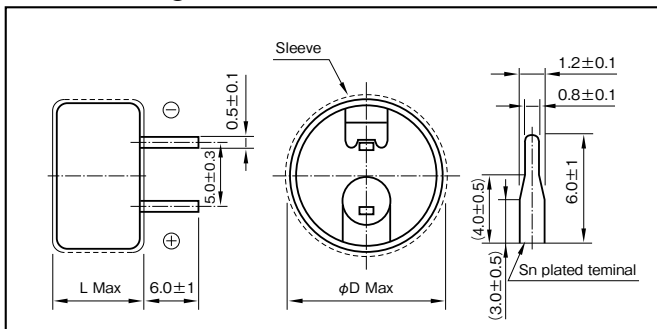

Standard Ratings

| Max. operating voltage (V) | Rated capacitance (F) | ELNA Parts No. | $\phi D \times L$ (mm) |
|----------------------------|-----------------------|----------------|------------------------|
| 5.5 | 0.047 | DB-5R5D473T | 13.5×7.5 |
| 5.5 | 0.1 | DB-5R5D104T | 13.5×7.5 |
| 5.5 | 0.22 | DB-5R5D224T | 13.5×7.5 |
| 5.5 | 0.33 | DB-5R5D334T | 13.5×7.5 |
| 5.5 | 0.47 | DB-5R5D474ST | 13.5×7.5 |
| 5.5 | 0.47 | DB-5R5D474T | 21.5×8.0 |
| 5.5 | 1 | DB-5R5D105T | 21.5×8.0 |
| 5.5 | 1.5 | DB-5R5D155T | 21.5×8.0 |

Part numbering system (example : 5.5V0.1F)

| | | | | | | |
|-------------|---|-------------------------------|---------------|--------------------------|-----------|-------------------|
| DB | — | 5R5 | D | 104 | \square | T |
| Series code | | Max. operating voltage symbol | Terminal code | Rated capacitance symbol | | Additional symbol |

Part number is refer to above table.

5.5V Low Resistance Series DBN

GREEN CAP

70°C

Low ESR

- Internal resistance was reduced to 85% to DB series.
- It excels in rapid charge.(It can charge and discharge with 1.5 times as much current (mA) as rated capacitance.)

Specifications

| Item | Performance | | | | | | | | |
|---|---|--|-----|------|------|--------------------|--------------------|----|-----|
| Category temperature range (°C) | -25 to +70 | | | | | | | | |
| Tolerance at rated capacitance (%) | -20 to +80 | | | | | | | | |
| Internal resistance at 1 kHz | Rated capacitance (F) | 0.047 | 0.1 | 0.22 | 0.33 | 0.47 | 0.47 | 1 | 1.5 |
| | Internal resistance (Ω) | 25 | 25 | 25 | 25 | 25 ($\phi 13.5$) | 20 ($\phi 21.5$) | 20 | 20 |
| Characteristics at high and low temperature | Percentage of capacitance change | Within $\pm 30\%$ of the value at 20°C | | | | | | | |
| | Internal resistance | Less than five times of the value at 20°C | | | | | | | |
| Endurance (70°C) | Test time | 1000 hours | | | | | | | |
| | Percentage of capacitance change | Within $\pm 30\%$ of the initial measured value | | | | | | | |
| | Internal resistance | Within four times of the initial specified value | | | | | | | |
| Shelf life (70°C) | Test time : 1000 hours ; Same as endurance. | | | | | | | | |
| Applicable standards | Conforms to JIS C5160-1 2009 (IEC 62391-1 2006) | | | | | | | | |

Standard Ratings

| Max. operating voltage (V) | Rated capacitance (F) | ELNA Parts No. | $\phi D \times L$ (mm) |
|----------------------------|-----------------------|----------------|------------------------|
| 5.5 | 0.047 | DBN-5R5D473T | 13.5×7.5 |
| 5.5 | 0.1 | DBN-5R5D104T | 13.5×7.5 |
| 5.5 | 0.22 | DBN-5R5D224T | 13.5×7.5 |
| 5.5 | 0.33 | DBN-5R5D334T | 13.5×7.5 |
| 5.5 | 0.47 | DBN-5R5D474ST | 13.5×7.5 |
| 5.5 | 0.47 | DBN-5R5D474T | 21.5×8.0 |
| 5.5 | 1 | DBN-5R5D105T | 21.5×8.0 |
| 5.5 | 1.5 | DBN-5R5D155T | 21.5×8.0 |

Part numbering system (example : 5.5V0.047F)

| | | | | | | |
|-------------|---|-------------------------------|---------------|--------------------------|-----------|-------------------|
| DBN | — | 5R5 | D | 473 | \square | T |
| Series code | | Max. operating voltage symbol | Terminal code | Rated capacitance symbol | | Additional symbol |

Part number is refer to left table.

NOTE : Design, Specifications are subject to change without notice. It is recommended that you shall obtain technical specifications from ELNA to ensure that the component is suitable for your use.

5.5V Low Profile and High Temperature Capacitors

GREEN CAP

85°C

- High temperature type of series DB.
- Small-sized, large capacity, excellent voltage holding.
- For all ratings, uniform 5mm pitch of terminal spacing.
- $\phi 13.5 \times 7.5L$ size can encase up to 0.33F.
- Ideal for backing up of CMOS's, IC's, microcomputers, RAM's, RTC's and the like used in Video's, tuners, TV sets, telephone sets and others.

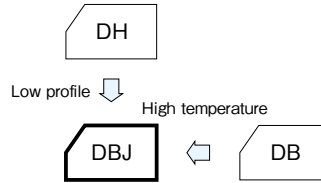

Marking color : White print on a black sleeve

Specifications

| Item | Performance | | | | | | |
|---|---|--|-----|------|------|------|----|
| Category temperature range (°C) | -10 to +85 | | | | | | |
| Tolerance at rated capacitance (%) | -20 to +80 | | | | | | |
| Internal resistance at 1 kHz | Rated capacitance (F) | 0.047 | 0.1 | 0.22 | 0.33 | 0.47 | 1 |
| | Internal resistance (Ω Max.) | 200 | 150 | 150 | 150 | 100 | 75 |
| Characteristics at high and low temperature | Percentage of capacitance change | Within $\pm 30\%$ of the value at 20°C | | | | | |
| | Internal resistance | Less than four times of the initial specified value. | | | | | |
| Endurance (85°C) | Test time | 1000 hours | | | | | |
| | Percentage of capacitance change | Within $\pm 30\%$ of the initial measured value | | | | | |
| | Internal resistance | Less than four times of the initial specified value | | | | | |
| Shelf life (85°C) | Test time : 1000 hours ; Same as endurance. | | | | | | |
| Applicable standards | Conforms to JIS C5160-1 2009 (IEC 62391-1 2006) | | | | | | |

Outline Drawing

Unit : mm

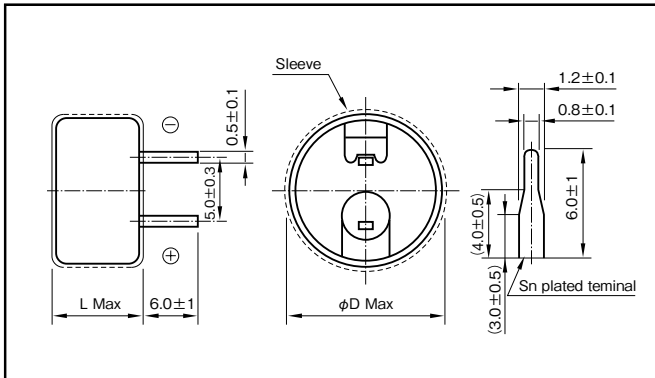

Part numbering system (example : 5.5V0.1F)

| | | | | | |
|-------------|---|------------------------------|---|--------------------------|---|
| DBJ | — | 5R5 | D | 104 | T |
| Series code | | Max.operating voltage symbol | | Rated capacitance symbol | |

Part number is refer to following table.

Standard Ratings

| Max. operating voltage (V) | Rated capacitance (F) | ELNA Parts No. | $\phi D \times L$ (mm) |
|----------------------------|-----------------------|----------------|------------------------|
| 5.5 | 0.047 | DBJ-5R5D473T | 13.5×7.5 |
| 5.5 | 0.1 | DBJ-5R5D104T | 13.5×7.5 |
| 5.5 | 0.22 | DBJ-5R5D224T | 13.5×7.5 |
| 5.5 | 0.33 | DBJ-5R5D334T | 13.5×7.5 |
| 5.5 | 0.47 | DBJ-5R5D474T | 21.5×8.0 |
| 5.5 | 1 | DBJ-5R5D105T | 21.5×8.0 |

NOTE : Design, Specifications are subject to change without notice. It is recommended that you shall obtain technical specifications from ELNA to ensure that the component is suitable for your use.

3.6V Low Profile and Low ESR High Temperature Capacitors

GREEN CAP

85°C

- Long life of 3.6V 2000 hours in small size low ESR.
- For all ratings, uniform 5mm pitch of terminal spacing.
- Wider temperature range (-25 to +85°C) than battery.
- $\phi 13.5 \times 7.5L$ size can encase up to 0.47F.
- Ideal for backing up of CMOS's, IC's, microcomputers, RAM's, RTC's and the like used in Video's, tuners, TV sets, telephone sets and others.
- It excels in rapid charge.

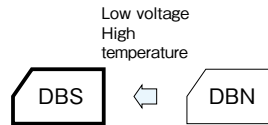

Marking color : White print on a black sleeve

Specifications

| Item | Performance | | | | | | | |
|---|---|--|-----|------|------|--------------------|--------------------|----|
| Category temperature range (°C) | -25 to +85 | | | | | | | |
| Tolerance at rated capacitance (%) | -20 to +80 | | | | | | | |
| Internal resistance at 1 kHz | Rated capacitance (F) | 0.047 | 0.1 | 0.22 | 0.33 | 0.47 | 0.47 | 1 |
| | Internal resistance (Ω Max.) | 25 | 25 | 25 | 25 | 25 ($\phi 13.5$) | 20 ($\phi 21.5$) | 20 |
| Characteristics at high and low temperature | Percentage of capacitance change | Within $\pm 30\%$ of the value at 20°C | | | | | | |
| | Internal resistance | Less than five times of the value at 20°C | | | | | | |
| Endurance (85°C) | Test time | 2000 hours ($\phi 13.5$ 0.47F : 1000 hours) | | | | | | |
| | Percentage of capacitance change | Within $\pm 30\%$ of the initial measured value | | | | | | |
| | Internal resistance | Within four times of the initial specified value | | | | | | |
| Shelf life (85°C) | Test time : 1000 hours ; Same as endurance. | | | | | | | |
| Applicable standards | Conforms to JIS C5160-1 2009 (IEC 62391-1 2006) | | | | | | | |

Outline Drawing

Unit : mm

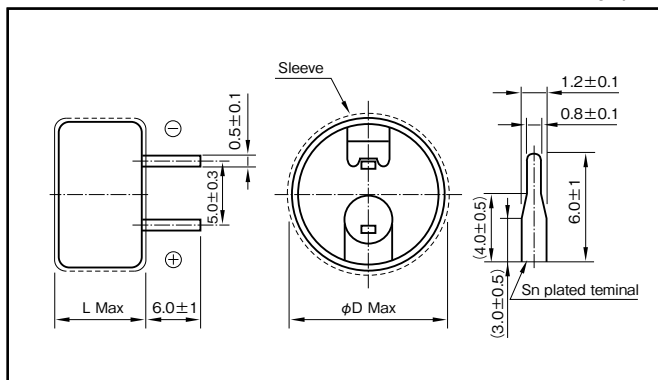

Part numbering system (example : 3.6V0.1F)

| | | | | | |
|-------------|---|-------------------------------|---------------|--------------------------|-------------------|
| DBS | — | 3R6 | D | 104 | T |
| Series code | | Max. operating voltage symbol | Terminal code | Rated capacitance symbol | Additional symbol |

Part number is refer to following table.

Standard Ratings

| Max. operating voltage (V) | Rated capacitance (F) | ELNA Parts No. | $\phi D \times L$ (mm) |
|----------------------------|-----------------------|----------------|------------------------|
| 3.6 | 0.047 | DBS-3R6D473T | 13.5 × 7.5 |
| 3.6 | 0.1 | DBS-3R6D104T | 13.5 × 7.5 |
| 3.6 | 0.22 | DBS-3R6D224T | 13.5 × 7.5 |
| 3.6 | 0.33 | DBS-3R6D334T | 13.5 × 7.5 |
| 3.6 | 0.47 | DBS-3R6D474ST | 13.5 × 7.5 |
| 3.6 | 0.47 | DBS-3R6D474T | 21.5 × 8.0 |
| 3.6 | 1 | DBS-3R6D105T | 21.5 × 8.0 |

5.5V Miniaturized Standard Capacitors

GREEN CAP 70°C

- Smaller and lighter than Series DB.
- 5mm tall. Max. thin profile (H-shaped).
- Miniaturized but can encase up to 0.47F in 11.5×5mm case, and 1.5F in φ19.0×20.5Lmm case.

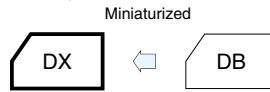

Marking color : White print on an indigo sleeve

Specifications

| Item | Performance | | | | | | | | | |
|---|---|---|-----|------|------|------------|------------|----|-----|--|
| Category temperature range (°C) | -25 to +70 | | | | | | | | | |
| Tolerance at rated capacitance (%) | -20 to +80 | | | | | | | | | |
| Internal resistance at 1 kHz | Rated capacitance (F) | 0.047 | 0.1 | 0.22 | 0.33 | 0.47 | 0.47 | 1 | 1.5 | |
| | Internal resistance (Ω Max.) | 120 | 75 | 75 | 75 | 75 (φ11.5) | 30 (φ19.0) | 30 | 30 | |
| Characteristics at high and low temperature | Percentage of capacitance change | Within ±30% of the value at 20°C | | | | | | | | |
| | Internal resistance | Less than five times of the value at 20°C | | | | | | | | |
| Endurance (70°C) | Test time | 1000 hours | | | | | | | | |
| | Percentage of capacitance change | Within ±30% of the initial measured value | | | | | | | | |
| | Internal resistance | Less than four times of the initial specified value | | | | | | | | |
| Shelf life (70°C) | Test time : 1000 hours ; Same as endurance. | | | | | | | | | |
| Applicable standards | Conforms to JIS C5160-1 2009 (IEC 62391-1 2006) | | | | | | | | | |

Outline Drawing

Unit : mm

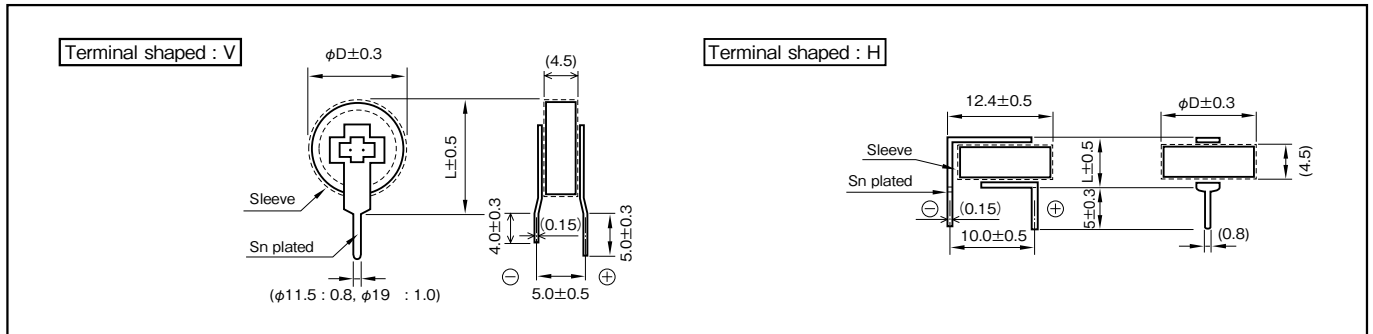

| | | | | | | |
|--|---|------------------------------|---------------|--------------------------|-------------------|---|
| Part numbering system (example : 5.5V0.1F) | | | | | | |
| DX | — | 5R5 | □ | 104 | □ | U |
| Series code | | Max.operating voltage symbol | Terminal code | Rated capacitance symbol | Additional symbol | |

Note

Do not apply external force to products or terminals as stress such as twisting, bending, pushing, or falling of such products or terminals may remove the terminals, resulting in an open/short circuit or liquid leakage. Avoid applying excessive heat to capacitors during heating of an adhesive curing oven. For details, refer to the precautions in use of DYNACAP.

Part number is refer to following table.

Standard Ratings

| Max. operating voltage (V) | Rated capacitance (F) | ELNA Parts No. | φD×L (mm) |
|----------------------------|-----------------------|----------------|-----------|
| 5.5 | 0.047 | DX-5R5V473U | 11.5×13.0 |
| | | DX-5R5H473U | 11.5× 5.0 |
| 5.5 | 0.1 | DX-5R5V104U | 11.5×13.0 |
| | | DX-5R5H104U | 11.5× 5.0 |
| 5.5 | 0.22 | DX-5R5V224U | 11.5×13.0 |
| | | DX-5R5H224U | 11.5× 5.0 |
| 5.5 | 0.33 | DX-5R5V334U | 11.5×13.0 |
| | | DX-5R5H334U | 11.5× 5.0 |
| 5.5 | 0.47 | DX-5R5V474SU | 11.5×13.0 |
| | | DX-5R5H474SU | 11.5× 5.0 |
| | | DX-5R5V474U | 19.0×20.5 |
| 5.5 | 1 | DX-5R5V105U | 19.0×20.5 |
| 5.5 | 1.5 | DX-5R5V155U | 19.0×20.5 |

NOTE : Design, Specifications are subject to change without notice. It is recommended that you shall obtain technical specifications from ELNA to ensure that the component is suitable for your use.

5.5V Miniaturized Low Resistance Capacitors

GREEN CAP 70°C

- Internal resistance was reduced to 85% to DX series and this size.
- 5mm tall. Max. thin profile (H-shaped).
- Miniaturized but can encase up to 0.47F in 11.5×5mm case, and 1.5F in $\phi 19.0 \times 20.5$ mm case.
- It excels in rapid charge.
(It can charge and discharge with 1.5 times as much current (mA) as rated capacitance.)

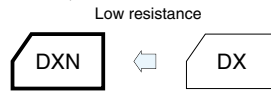

Marking color : White print on an indigo sleeve

Specifications

| Item | Performance | | | | | | | | |
|---|--|---|-----|------|------|--------------------|--------------------|----|-----|
| Category temperature range (°C) | -25 to +70 | | | | | | | | |
| Tolerance at rated capacitance (%) | -20 to +80 | | | | | | | | |
| Internal resistance at 1 kHz | Rated capacitance (F) | 0.047 | 0.1 | 0.22 | 0.33 | 0.47 | 0.47 | 1 | 1.5 |
| | Internal resistance (Ω Max.) | 25 | 25 | 25 | 25 | 25 ($\phi 11.5$) | 20 ($\phi 19.0$) | 20 | 20 |
| Characteristics at high and low temperature | Percentage of capacitance change | Within $\pm 30\%$ of the value at 20°C | | | | | | | |
| | Internal resistance | Less than five times of the value at 20°C | | | | | | | |
| Endurance (70°C) | Test time | 1000 hours | | | | | | | |
| | Percentage of capacitance change | Within $\pm 30\%$ of the initial measured value | | | | | | | |
| | Internal resistance | Less than four times of the initial specified value | | | | | | | |
| Shelf life (70°C) | Test time : 1000 hours ; Same as endurance. | | | | | | | | |
| Applicable standards | Conforms to JIS C5160-1 2009(IEC 62391-1 2006) | | | | | | | | |

Outline Drawing

Unit : mm

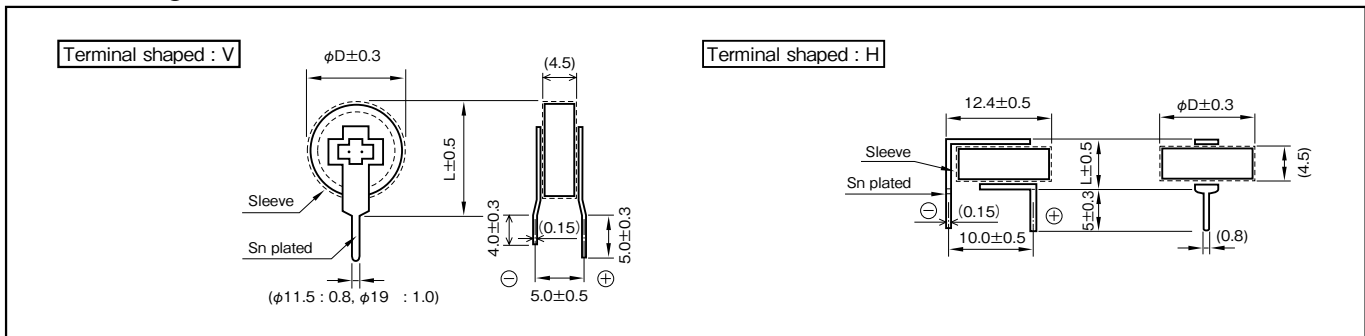

Part numbering system (example : 5.5V0.1F)

| | | | | | | |
|-------------|---|------------------------------|---------------|--------------------------|-------------------|---|
| DXN | — | 5R5 | \square | 104 | \square | U |
| Series code | | Max.operating voltage symbol | Terminal code | Rated Capacitance symbol | Additional symbol | |

Part number is refer to following table.

Note

Do not apply external force to products or terminals as stress such as twisting, bending, pushing, or falling of such products or terminals may remove the terminals, resulting in an open/short circuit or liquid leakage. Avoid applying excessive heat to capacitors during heating of an adhesive curing oven. For details, refer to the precautions in use of DYNACAP.

Standard Ratings

| Max. operating voltage (V) | Rated capacitance (F) | ELNA Parts No. | $\phi D \times L$ (mm) |
|----------------------------|-----------------------|----------------|------------------------|
| 5.5 | 0.047 | DXN-5R5V473U | 11.5×13.0 |
| | | DXN-5R5H473U | 11.5× 5.0 |
| 5.5 | 0.1 | DXN-5R5V104U | 11.5×13.0 |
| | | DXN-5R5H104U | 11.5× 5.0 |
| 5.5 | 0.22 | DXN-5R5V224U | 11.5×13.0 |
| | | DXN-5R5H224U | 11.5× 5.0 |
| 5.5 | 0.33 | DXN-5R5V334U | 11.5×13.0 |
| | | DXN-5R5H334U | 11.5× 5.0 |
| 5.5 | 0.47 | DXN-5R5V474SU | 11.5×13.0 |
| | | DXN-5R5H474SU | 11.5× 5.0 |
| | | DXN-5R5V474U | 19.0×20.5 |
| 5.5 | 1 | DXN-5R5V105U | 19.0×20.5 |
| 5.5 | 1.5 | DXN-5R5V155U | 19.0×20.5 |

5.5V Miniaturized High Temperature Capacitors

GREEN CAP

85°C

- High temperature type of Series DX.
- 5mm tall. Max. thin profile (H-shaped).
- Miniaturized but can encase up to 0.33F in 11.5×5mm case, and 1.0F in φ19.0×20.5Lmm case.

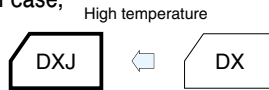

Marking color : White print on a black sleeve

Specifications

| Item | Performance | | | | | |
|---|---|--|-----|------|------|----|
| Category temperature range (°C) | -10 to +85 | | | | | |
| Tolerance at rated capacitance (%) | -20 to +80 | | | | | |
| Internal resistance at 1 kHz | Rated capacitance (F) | 0.047 | 0.1 | 0.22 | 0.33 | 1 |
| | Internal resistance (Ω Max.) | 200 | 150 | 150 | 150 | 75 |
| Characteristics at high and low temperature | Percentage of capacitance change | Within ±30% of the value at 20°C | | | | |
| | Internal resistance | Less than four times of the initial specified value. | | | | |
| Endurance (85°C) | Test time | 1000 hours | | | | |
| | Percentage of capacitance change | Within ±30% of the initial measured value | | | | |
| | Internal resistance | Less than four times of the initial specified value | | | | |
| Shelf life (85°C) | Test time : 1000 hours ; Same as endurance. | | | | | |
| Applicable standards | Conforms to JIS C5160-1 2009 (IEC 62391-1 2006) | | | | | |

Outline Drawing

Unit : mm

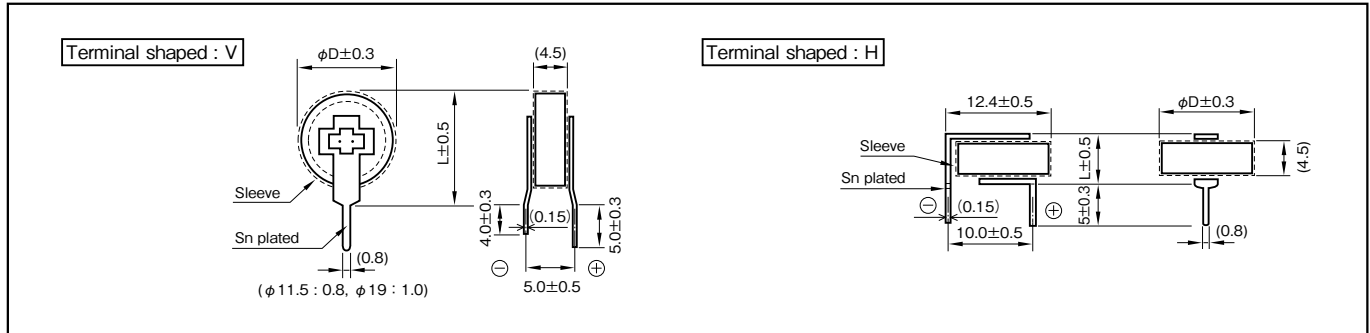

| Part numbering system (example : 5.5V0.1F) | | | | | | |
|--|---|------------------------------|---------------|--------------------------|-------------------|---|
| DXJ | — | 5R5 | □ | 104 | □ | U |
| Series code | | Max.operating voltage symbol | Terminal code | Rated Capacitance symbol | Additional symbol | |

Part number is refer to following table.

Note

Do not apply external force to products or terminals as stress such as twisting, bending, pushing, or falling of such products or terminals may remove the terminals, resulting in an open/short circuit or liquid leakage. Avoid applying excessive heat to capacitors during heating of an adhesive curing oven. For details, refer to the precautions in use of DYNACAP.

Standard Ratings

| Max. operating voltage (V) | Rated capacitance (F) | ELNA Parts No. | φD×L (mm) |
|----------------------------|-----------------------|----------------|-----------|
| 5.5 | 0.047 | DXJ-5R5V473U | 11.5×13.0 |
| | | DXJ-5R5H473U | 11.5× 5.0 |
| 5.5 | 0.1 | DXJ-5R5V104U | 11.5×13.0 |
| | | DXJ-5R5H104U | 11.5× 5.0 |
| 5.5 | 0.22 | DXJ-5R5V224U | 11.5×13.0 |
| | | DXJ-5R5H224U | 11.5× 5.0 |
| 5.5 | 0.33 | DXJ-5R5V334U | 11.5×13.0 |
| | | DXJ-5R5H334U | 11.5× 5.0 |
| 5.5 | 1 | DXJ-5R5V105U | 19.0×20.5 |

NOTE : Design, Specifications are subject to change without notice. It is recommended that you shall obtain technical specifications from ELNA to ensure that the component is suitable for your use.

3.6V Miniaturized Low ESR High Temperature Capacitors

GREEN CAP

85°C

- Long life of 3.6V 2000 hours, low ESR in DX series and this size.
- 5mm tall. Max. thin profile (H-shaped).
- Wider temperature range (-25 to +85°C) than battery.
- Miniaturized but can encase up to 0.47F in 11.5x5mm case and 1.0F in 19.0x20.5L mm case.
- It excels in rapid charge.



Marking color : White print on a black sleeve

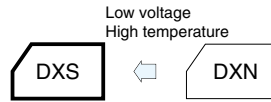

Specifications

| Item | Performance | | | | | | | |
|---|--|---|-----|------|------|-------------|-------------|----|
| Category temperature range (°C) | -25 to +85 | | | | | | | |
| Tolerance at rated capacitance (%) | -20 to +80 | | | | | | | |
| Internal resistance at 1 kHz | Rated capacitance (F) | 0.047 | 0.1 | 0.22 | 0.33 | 0.47 | 0.47 | 1 |
| | Internal resistance (Ω Max.) | 25 | 25 | 25 | 25 | 25 (φ 11.5) | 20 (φ 19.0) | 20 |
| Characteristics at high and low temperature | Percentage of capacitance change | Within ±30% of the value at 20°C | | | | | | |
| | Internal resistance | Less than five times of the value at 20°C | | | | | | |
| Endurance (85°C) | Test time | 2000 hours (φ 11.5 0.47F : 1000 hours) | | | | | | |
| | Percentage of capacitance change | Within ±30% of the initial measured value | | | | | | |
| | Internal resistance | Less than four times of the initial specified value | | | | | | |
| Shelf life (85°C) | Test time : 1000 hours ; Same as endurance. | | | | | | | |
| Applicable standards | Conforms to JIS C5160-1 2009(IEC 62391-1 2006) | | | | | | | |

Outline Drawing

Unit : mm

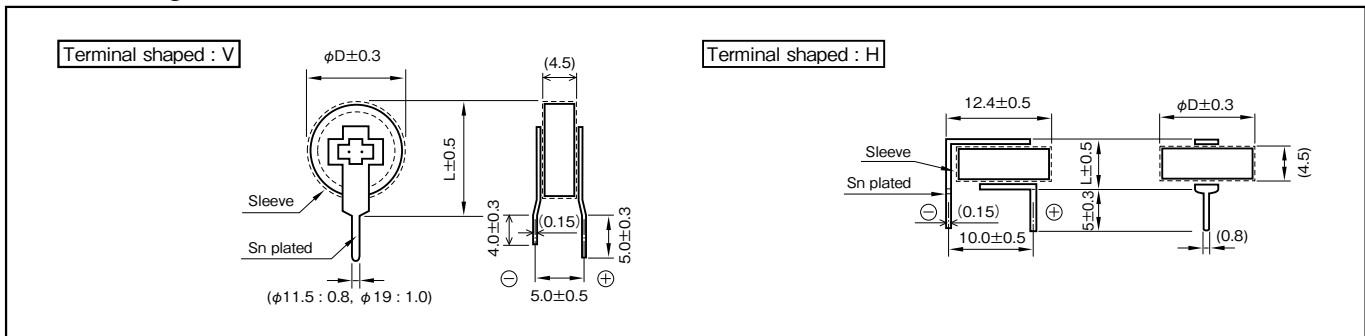

Part numbering system (example : 3.6V0.1F)

| | | | | | | |
|-------------|---|------------------------------|-----------------|--------------------------|-------------------|---|
| DXS | — | 3R6 | □ | 104 | □ | U |
| Series code | | Max.operating voltage symbol | Terminal shaped | Rated capacitance symbol | Additional symbol | |

Part number is refer to following table.

Note

Do not apply external force to products or terminals as stress such as twisting, bending, pushing, or falling of such products or terminals may remove the terminals, resulting in an open/short circuit or liquid leakage. Avoid applying excessive heat to capacitors during heating of an adhesive curing oven. For details, refer to the precautions in use of DYNACAP.

Standard Ratings

DXS-5R5V105U

| Max. operating voltage (V) | Rated capacitance (F) | ELNA Parts No. | φD×L (mm) |
|----------------------------|-----------------------|----------------|-----------|
| 3.6 | 0.047 | DXS-3R6V473U | 11.5×13.0 |
| | | DXS-3R6H473U | 11.5× 5.0 |
| 3.6 | 0.1 | DXS-3R6V104U | 11.5×13.0 |
| | | DXS-3R6H104U | 11.5× 5.0 |
| 3.6 | 0.22 | DXS-3R6V224U | 11.5×13.0 |
| | | DXS-3R6H224U | 11.5× 5.0 |
| 3.6 | 0.33 | DXS-3R6V334U | 11.5×13.0 |
| | | DXS-3R6H334U | 11.5× 5.0 |
| 3.6 | 0.47 | DXS-3R6V474SU | 11.5×13.0 |
| | | DXS-3R6H474SU | 11.5× 5.0 |
| | | DXS-3R6V474U | 19.0×20.5 |
| 3.6 | 1 | DXS-3R6V105U | 19.0×20.5 |

High Voltage Tolerance Capacitors

GREEN CAP

70°C

- High voltage tolerant (6.3V guaranteed) and highly reliable.
- Ideal for backing up of Li-battery-backed equipment such as cameras, video and telephone sets.

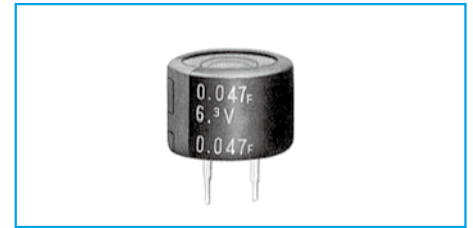
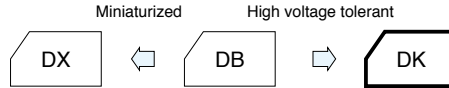

Marking color : White print on an indigo sleeve

Specifications

| Item | Performance | | | | | |
|---|---|---|-----|------|------|----|
| Category temperature range (°C) | -25 to +70 | | | | | |
| Tolerance at rated capacitance (%) | -20 to +80 | | | | | |
| Internal resistance at 1 kHz | Rated capacitance (F) | 0.047 | 0.1 | 0.47 | 0.68 | 1 |
| | Internal resistance (Ω Max.) | 300 | 200 | 50 | 50 | 30 |
| Characteristics at high and low temperature | Percentage of capacitance change | Within ±30% of the value at 20°C | | | | |
| | Internal resistance | Less than five times of the value at 20°C | | | | |
| Endurance (70°C) | Test time | 1000 hours | | | | |
| | Percentage of capacitance change | Within ±30% of the initial measured value | | | | |
| | Internal resistance | Less than four times of the initial specified value | | | | |
| Shelf life (70°C) | Test time : 1000 hours ; Same as endurance. | | | | | |
| Applicable standards | Conforms to JIS C5160-1 2009 (IEC 62391-1 2006) | | | | | |

Outline Drawing

Unit : mm

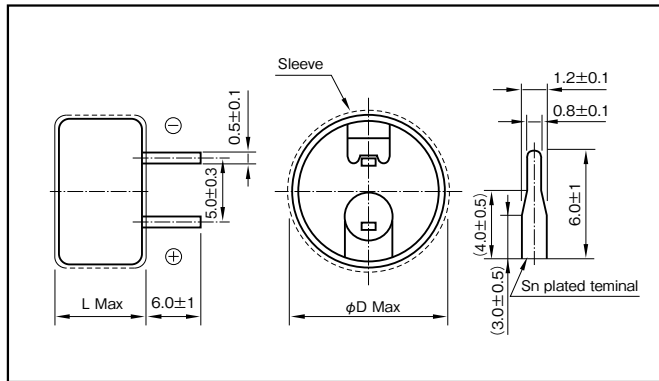

| Part numbering system (example : 6.3V0.1F) | | | |
|--|---|------------------------------|--------------------------|
| DK | — | 6R3 | D 104 T |
| Series code | | Max.operating voltage symbol | Rated capacitance symbol |

Part number is refer to following table.

Standard Ratings

| Max. operating voltage (V) | Rated capacitance (F) | ELNA Parts No. | φD×L (mm) |
|----------------------------|-----------------------|----------------|-----------|
| 6.3 | 0.047 | DK-6R3D473T | 13.5×9.5 |
| 6.3 | 0.1 | DK-6R3D104T | 13.5×9.5 |
| 6.3 | 0.47 | DK-6R3D474T | 21.5×9.5 |
| 6.3 | 0.68 | DK-6R3D684T | 21.5×9.5 |
| 6.3 | 1 | DK-6R3D105T | 21.5×9.5 |

NOTE : Design, Specifications are subject to change without notice. It is recommended that you shall obtain technical specifications from ELNA to ensure that the component is suitable for your use.

High Temperature Capacitors

GREEN CAP 85°C

- High temperature tolerant (−25 to +85°C) and highly reliable.
- Ideal for backing up of controls, electronic rice cooking jars, home bakeries and the like.

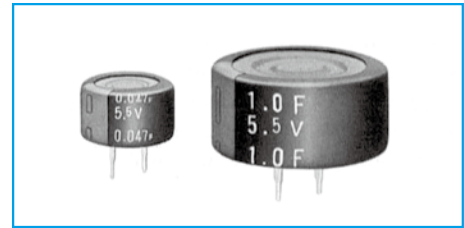
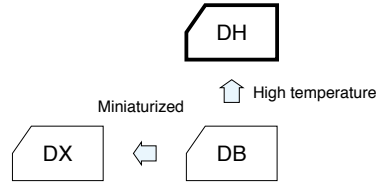

Marking color : White print on an indigo sleeve

Specifications

| Item | Performance | | | | | | | |
|---|---|---|-----|------|------|------|----|--|
| Category temperature range (°C) | −25 to +85 | | | | | | | |
| Tolerance at rated capacitance (%) | −20 to +80 | | | | | | | |
| Internal resistance at 1 kHz | Rated capacitance (F) | 0.047 | 0.1 | 0.22 | 0.47 | 0.68 | 1 | |
| | Internal resistance (Ω Max.) | 300 | 200 | 120 | 50 | 50 | 30 | |
| Characteristics at high and low temperature | Percentage of capacitance change | Within ±30% of the value at 20°C | | | | | | |
| | Internal resistance | Less than five times of the value at 20°C | | | | | | |
| Endurance (85°C) | Test time | 1000 hours | | | | | | |
| | Percentage of capacitance change | Within ±30% of the initial measured value | | | | | | |
| | Internal resistance | Less than four times of the initial specified value | | | | | | |
| Shelf life (85°C) | Test time : 1000 hours ; Same as endurance. | | | | | | | |
| Applicable standards | Conforms to JIS C5160-1 2009 (IEC 62391-1 2006) | | | | | | | |

Outline Drawing

Unit : mm

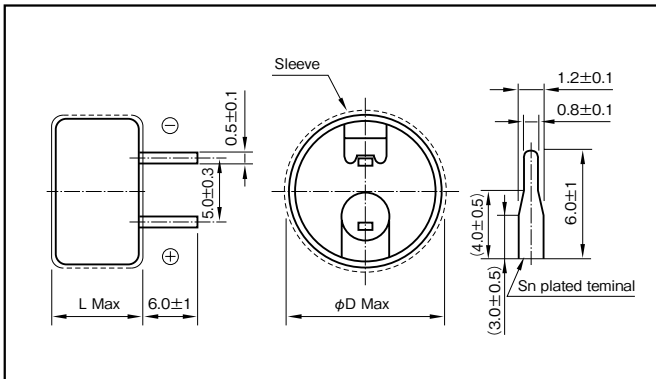

Part numbering system (example : 5.5V0.1F)

| | | | | | |
|-------------|---|------------------------------|---|--------------------------|---|
| DH | — | 5R5 | D | 104 | T |
| Series code | | Max.operating voltage symbol | | Rated capacitance symbol | |

Part number is refer to following table.

Standard Ratings

| Max. operating voltage (V) | Rated capacitance (F) | ELNA Parts No. | φD×L (mm) |
|----------------------------|-----------------------|----------------|-----------|
| 5.5 | 0.047 | DH-5R5D473T | 13.5×9.5 |
| 5.5 | 0.1 | DH-5R5D104T | 13.5×9.5 |
| 5.5 | 0.22 | DH-5R5D224T | 13.5×9.5 |
| 5.5 | 0.47 | DH-5R5D474T | 21.5×9.5 |
| 5.5 | 0.68 | DH-5R5D684T | 21.5×9.5 |
| 5.5 | 1 | DH-5R5D105T | 21.5×9.5 |

5.5V Wide Temperature Range Capacitors

GREEN CAP

85°C

- It is a category temperature range larger than battery.
- $\phi 13.5$ size can encase up to 0.22F, $\phi 21.5$ size can encase up to 1.0F.
- It excels in rapid charge.
- Ideal for backing up of CMOS IC's, microcomputers, RAM's, RTC's for smart meter, outdoor equipment, auto motive and industrial.

Wide temperature range

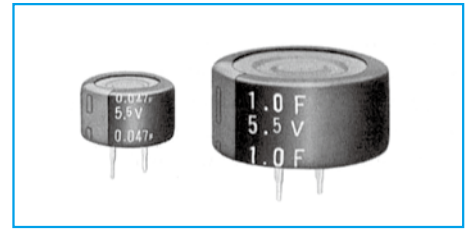

Marking color : White print on an indigo sleeve

Specifications

| Item | Performance | | | | | | | |
|---|---|--|-----|------|------|------|----|--|
| Category temperature range (°C) | -40 to +85 | | | | | | | |
| Tolerance at rated capacitance (%) | -20 to +80 | | | | | | | |
| Internal resistance at 1 kHz | Rated capacitance (F) | 0.047 | 0.1 | 0.22 | 0.47 | 0.68 | 1 | |
| | Internal resistance (Ω Max.) | 40 | 40 | 40 | 20 | 20 | 20 | |
| Characteristics at high and low temperature | Percentage of capacitance change | Within $\pm 30\%$ of the value at 20°C | | | | | | |
| | Internal resistance | -40°C : Less than seven times of the value at 20°C 85°C : Less than five times of the value at 20°C | | | | | | |
| Endurance (85°C) | Test time | 1000 hours | | | | | | |
| | Percentage of capacitance change | Within $\pm 30\%$ of the initial measured value | | | | | | |
| | Internal resistance | Less than four times of the initial specified value | | | | | | |
| Shelf life (85°C) | Test time : 1000 hours ; Same as endurance. | | | | | | | |
| Applicable standards | Conforms to JIS C5160-1 2009 (IEC 62391-1 2006) | | | | | | | |

Outline Drawing

Unit : mm

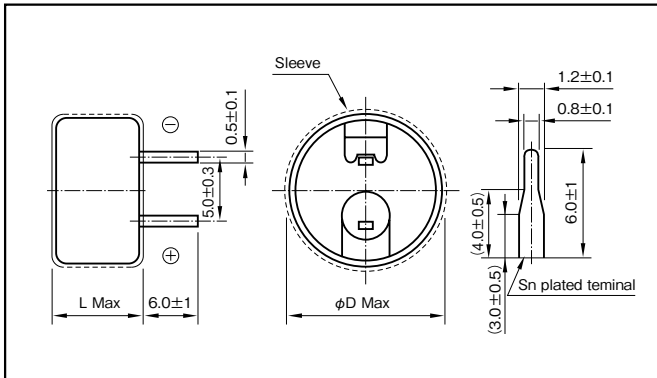

Part numbering system (example : 5.5V0.1F)

| | | | | | |
|-------------|---|----------------------|---------------|--------------------------|---|
| DHL | — | 5R5 | D | 104 | T |
| Series code | | Rated voltage symbol | Terminal code | Rated capacitance symbol | |

Part number is refer to following table.

Standard Ratings

| Max. operating voltage (V) | Rated capacitance (F) | ELNA Parts No. | $\phi D \times L$ (mm) |
|----------------------------|-----------------------|----------------|------------------------|
| 5.5 | 0.047 | DHL-5R5D473T | 13.5×9.5 |
| 5.5 | 0.1 | DHL-5R5D104T | 13.5×9.5 |
| 5.5 | 0.22 | DHL-5R5D224T | 13.5×9.5 |
| 5.5 | 0.47 | DHL-5R5D474T | 21.5×9.5 |
| 5.5 | 0.68 | DHL-5R5D684T | 21.5×9.5 |
| 5.5 | 1 | DHL-5R5D105T | 21.5×9.5 |

NOTE : Design, Specifications are subject to change without notice. It is recommended that you shall obtain technical specifications from ELNA to ensure that the component is suitable for your use.

5.5V High Temperature, Long Life Capacitors

GREEN CAP

85°C

- Guarantees 3000 hours at 85°C, 5.5V (10 years at room temperature).
- It is a category temperature range larger than battery.
- It excels in rapid charge.
- Ideal for backing up of CMOS IC's, microcomputers, RAM's, RTC's for smart meter, outdoor equipment, auto motive and industrial.

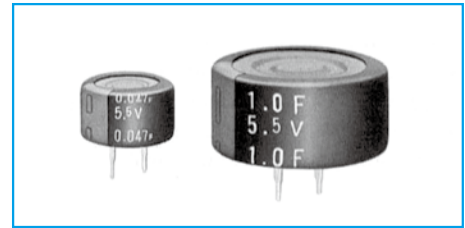

Marking color : White print on a Black sleeve

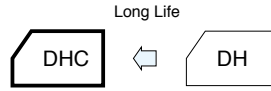

Specifications

| Item | Performance | | | | | | | |
|---|---|---|-----|------|------|------|----|--|
| Category temperature range (°C) | -25 to +85 | | | | | | | |
| Tolerance at rated capacitance (%) | -20 to +80 | | | | | | | |
| Internal resistance at 1 kHz | Rated capacitance (F) | 0.047 | 0.1 | 0.22 | 0.47 | 0.68 | 1 | |
| | Internal resistance (Ω Max.) | 300 | 200 | 120 | 50 | 50 | 30 | |
| Characteristics at high and low temperature | Percentage of capacitance change | Within ±30% of the value at 20°C | | | | | | |
| | Internal resistance | less than five times of the value at 20°C | | | | | | |
| Endurance (85°C) | Test time | 3000 hours | | | | | | |
| | Percentage of capacitance change | Within ±30% of the initial measured value | | | | | | |
| | Internal resistance | Less than four times of the initial specified value | | | | | | |
| Shelf life (85°C) | Test time : 1000 hours ; Same as endurance. | | | | | | | |
| Applicable standards | Conforms to JIS C5160-1 2009 (IEC 62391-1 2006) | | | | | | | |

Outline Drawing

Unit : mm

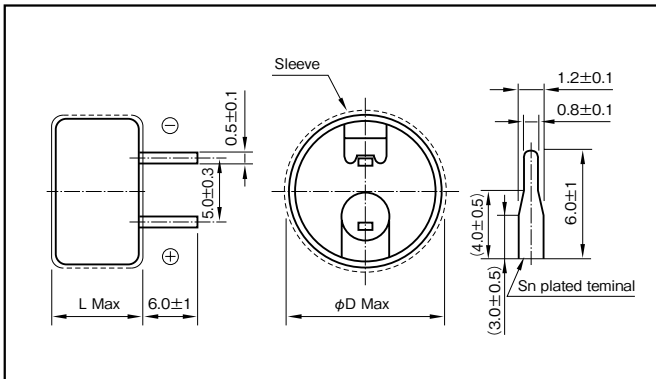

Part numbering system (example : 5.5V0.1F)

| | | | | | |
|-------------|---|----------------------|---------------|--------------------------|---|
| DHC | — | 5R5 | D | 104 | T |
| Series code | | Rated voltage symbol | Terminal code | Rated capacitance symbol | |

Part number is refer to following table.

Standard Ratings

| Max. operating voltage (V) | Rated capacitance (F) | ELNA Parts No. | φD×L (mm) |
|----------------------------|-----------------------|----------------|-----------|
| 5.5 | 0.047 | DHC-5R5D473T | 13.5×9.5 |
| 5.5 | 0.1 | DHC-5R5D104T | 13.5×9.5 |
| 5.5 | 0.22 | DHC-5R5D224T | 13.5×9.5 |
| 5.5 | 0.47 | DHC-5R5D474T | 21.5×9.5 |
| 5.5 | 0.68 | DHC-5R5D684T | 21.5×9.5 |
| 5.5 | 1 | DHC-5R5D105T | 21.5×9.5 |

Coin Cell Capacitors



- Unlike batteries, the number of charging / discharging cycles unlimited and rapid charging / discharging is possible.
- High reliability, Safe and unlike secondary batteries, this is pollution free devices.
- 1.8mm height 614type made lineup in the DC, DCK Series.

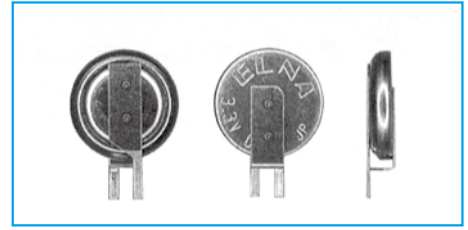
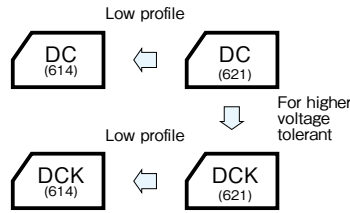

Specifications

| Item | Performance | | | | | |
|---|---|---|---|----------------------------------|--|---|
| Series Name | Series DC | | | Series DCK | | |
| Max. operating voltage (V) | 2.5 | | | 3.3 | | |
| Category temperature range (°C) | -25 to +70 | | | -10 to +60 | | |
| Tolerance at rated capacitance (%) | -20 to +80 | | | -20 to +80 | | |
| Internal resistance (Ω) at 1 kHz | Size code | 614 | 621 | Size code | 614 | 621 |
| | Rated capacitance (F) | 0.2 | 0.4 | Rated capacitance (F) | 0.2 | 0.4 |
| | Internal resistance (ΩMax.) | 100 | 100 | Internal resistance (ΩMax.) | 200 | 200 |
| Characteristics at high and low temperature | Size code | 614 | 621 | Size code | 614 | 621 |
| | Percentage of capacitance change | Within ±30% of the value at 20°C | Within ±30% of the value at 20°C | Percentage of capacitance change | Within ±50% of the value at 20°C | Within ±50% of the value at 20°C |
| | Internal resistance | Less than five times of the value at 20°C | Less than five times of the value at 20°C | Internal resistance | Less than five times the initial specified value | Less than five times of the value at 20°C |
| Endurance | Size code | 614 | 621 | Size code | 614 | 621 |
| | Test time and temp | 70°C 1000 hours | 70°C 500 hours | Test time and temp | 60°C 1000 hours | 60°C 500 hours |
| | Percentage of capacitance change | Within ±30% of the initial measured value | Within ±40% of the initial measured value | Percentage of capacitance change | Within ±30% of the initial measured value | Within ±40% of the initial measured value |
| | Internal resistance | 1kΩ Max. | 400Ω Max. | Internal resistance | 2kΩ Max. | 800Ω Max. |
| Shelf life | Same as endurance. | | | Same as endurance. | | |
| Applicable standards | Conforms to JIS C5160-1 2009 (IEC 62391-1 2006) | | | | | |

Outline Drawing

Unit : mm

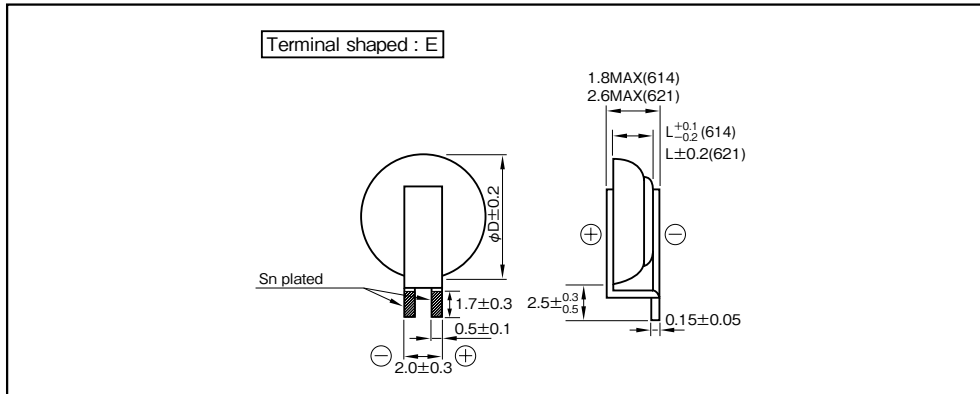

Part numbering system (example : 614, 2.5V0.2F, terminal shaped : E)

| | | | | | | | |
|-------------|---|-------------------------------|---|--------------------------|-------------------|---|---|
| DC | — | 2R5 | E | 204 | T 614 | — | E |
| Series code | | Max. operating voltage symbol | | Rated capacitance symbol | Additional symbol | | |

Part number is refer to following table.

Part numbering system (example : 621, 3.3V0.4F, terminal shaped : E)

| | | | | | | | |
|-------------|---|-------------------------------|---|--------------------------|-------------------|---|---|
| DCK | — | 3R3 | E | 404 | T | — | E |
| Series code | | Max. operating voltage symbol | | Rated capacitance symbol | Additional symbol | | |

Part number is refer to following table.

Standard Ratings

| Max. operating voltage (V) | Rated capacitance (F) | ELNA Parts No. | φD×L (mm) |
|----------------------------|-----------------------|-------------------|-----------|
| 2.5 | 0.2 | DC-2R5E204T614-E | 6.8×1.4 |
| 3.3 | 0.2 | DCK-3R3E204T614-E | 6.8×1.4 |
| 2.5 | 0.4 | DC-2R5E404T-E | 6.8×2.1 |
| 3.3 | 0.4 | DCK-3R3E404T-E | 6.8×2.1 |

NOTE : Design, Specifications are subject to change without notice. It is recommended that you shall obtain technical specifications from ELNA to ensure that the component is suitable for your use.

Coin Cell Capacitors

GREEN CAP

70°C

- Reflow soldering method available.
- Unlike batteries, the number of charging / discharging cycles unlimited and rapid charging / discharging is possible.
- Unlike batteries, excellent charge and discharge characteristics with no chemical reactions.
- $\phi 4.8 \times 1.71$ Lmm Max height type made lineup in the DSK series.

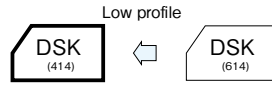

Specifications

| Item | Performance | |
|---|---|---|
| Series name | series DSK | |
| Max. operating voltage (V) | 3.3 | |
| Category temperature range (°C) | -10 to +70 | |
| Tolerance at rated capacitance (%) | -20 to +80 | |
| Rated capacitance (F) | 0.07 | |
| Internal resistance (Ω Max.) at 1 kHz | 100 | |
| Characteristics at high and low temperature | Percentage of capacitance change | Within $\pm 50\%$ of the value at 20°C |
| | Internal resistance | Less than ten times of the initial specified value. |
| Endurance (70°C) | Test time | 500 hours |
| | Percentage of capacitance change | Within $\pm 30\%$ of the initial measured value |
| | Internal resistance | 5k Ω or less |
| Shelf life (70°C) | Test time : 500 hours ; Same as endurance. | |
| Applicable standards | Conforms to JIS C5160-1 2009 (IEC 62391-1 2006) | |

Outline Drawing

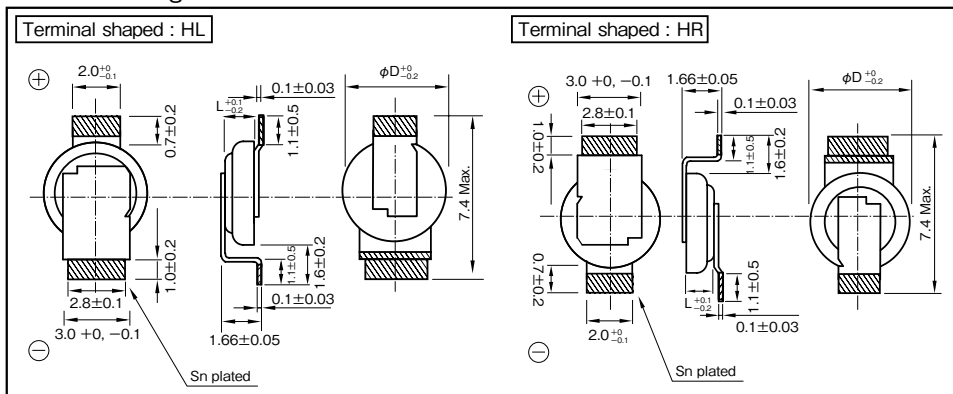

Recommended land pattern size

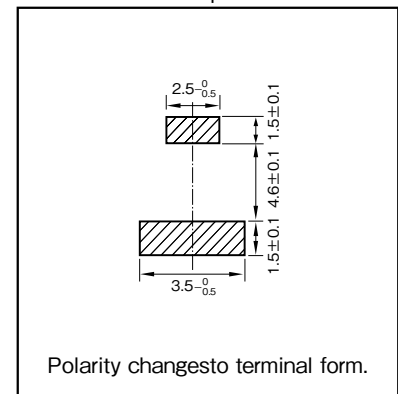

*Please consult with us about other terminal form

Part numbering system (3.3V0.07F, terminal shaped : HL)

| | | | | | | | | |
|-------------|-------------------------------|--------------------------|-------------------|-----------------|---------------|---|----|---|
| DSK | — | 3R3 | H | 703 | T414 | — | HL | L |
| Series code | Max. operating voltage symbol | Rated capacitance symbol | Additional symbol | Terminal shaped | Taping symbol | | | |

Part number is refer to following table.

Standard Ratings

| Max. operating voltage (V) | Rated capacitance (F) | ELNA Parts No. | $\phi D \times L$ (mm) |
|----------------------------|-----------------------|---------------------|------------------------|
| 3.3 | 0.07 | DSK-3R3H703T414-HLL | 4.8×1.4 |
| | | DSK-3R3H703T414-HRL | |

*Soldering conditions are described on page 191.

Coin Cell Capacitors



- Reflow soldering method available.
- Unlike batteries, the number of charging/ discharging cycles unlimited and rapid charging/ discharging is possible.
- Unlike batteries, excellent charge and discharge characteristics with no chemical reactions.
- 1.8mm height type 614 made lineup in the DS, DSK series.

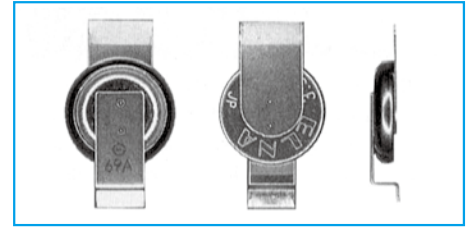
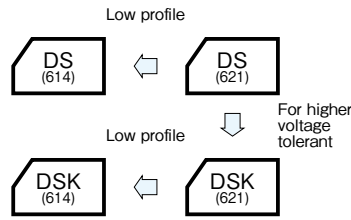

Specifications

| Item | Performance | | | | | |
|---|--|---|---|----------------------------------|---|---|
| | Series DS | | | Series DSK | | |
| Series Name | Series DS | | | Series DSK | | |
| Max. operating voltage (V) | 2.5 | | | 3.3 | | |
| Category temperature range (°C) | -25 to +70 | | | -10 to +60 | | |
| Tolerance at rated capacitance (%) | -20 to +80 | | | -20 to +80 | | |
| Internal resistance (Ω) at 1 kHz | Size code | 614 | 621 | Size code | 614 | 621 |
| | Rated capacitance (F) | 0.2 | 0.33 | Rated capacitance (F) | 0.2 | 0.33 |
| | Internal resistance (Ω Max.) | 100 | 100 | Internal resistance (Ω Max.) | 200 | 200 |
| Characteristics at high and low temperature | Size code | 614 | 621 | Size code | 614 | 621 |
| | Percentage of capacitance change | Within ±30% of the value at 20°C | Within ±30% of the value at 20°C | Percentage of capacitance change | Within ±50% of the value at 20°C | Within ±50% of the value at 20°C |
| | Internal resistance | Less than five times of the value at 20°C | Less than five times of the value at 20°C | Internal resistance | Less than five times of the initial specified value | Less than five times of the value at 20°C |
| Endurance | Size code | 614 | 621 | Size code | 614 | 621 |
| | Test time and temp. | 70°C 1000 hours | 70°C 500 hours | Test time and temp. | 60°C 1000 hours | 60°C 500 hours |
| | Percentage of capacitance change | Within ±30% of the initial measured value | Within ±30% of the initial measured value | Percentage of capacitance change | Within ±30% of the initial measured value | Within ±30% of the initial measured value |
| | Internal resistance | 1kΩ Max. | 400Ω Max. | Internal resistance | 2kΩ Max. | 800Ω Max. |
| Shelf life | Same as endurance. | | | Same as endurance. | | |
| Applicable standards | Conforms to JIS C5160-1 2009(IEC 62391-1 2006) | | | | | |

Outline Drawing

Unit : mm

Recommended land pattern size

Unit : mm

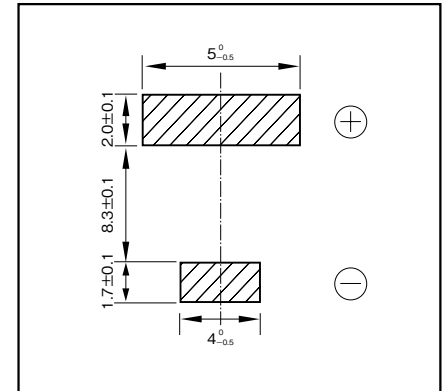
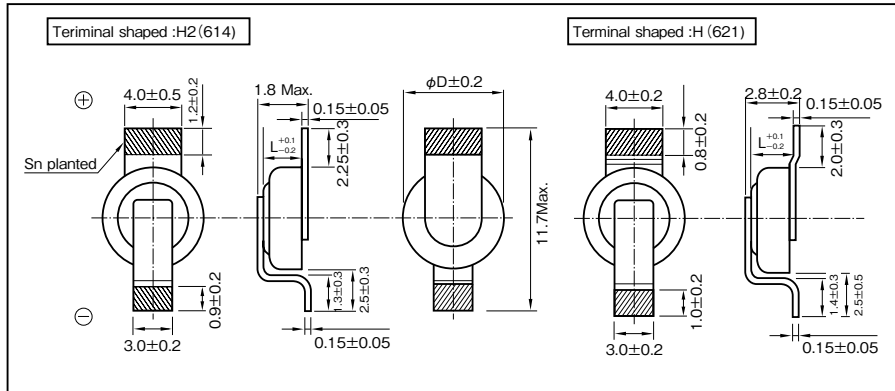

*Please consult with us about other terminal form.

| | | | | | | |
|---|-------------------------------|--------------------------|-------------------|-----------------|---------------|--------|
| Part numbering system (example : 614, 2.5V0.2F, terminal shaped : H2) | | | | | | |
| DS | — | 2R5 | H | 204 | T614 | — H2 L |
| Series code | Max. operating voltage symbol | Rated capacitance symbol | Additional symbol | Terminal shaped | Taping symbol | |

Part number is refer to following table.

| | | | | | | |
|---|-------------------------------|--------------------------|-------------------|-----------------|---------------|-------|
| Part numbering system (example:621, 3.3V0.33F, terminal shaped:H) | | | | | | |
| DSK | — | 3R3 | H | 334 | T | — H L |
| Series code | Max. operating voltage symbol | Rated capacitance symbol | Additional symbol | Terminal shaped | Taping symbol | |

Part number is refer to following table.

Standard Ratings

| Max. operating voltage (V) | Rated capacitance (F) | ELNA Parts No. | φD×L (mm) |
|----------------------------|-----------------------|---------------------|-----------|
| 2.5 | 0.2 | DS-2R5H204T614-H2L | 6.8×1.4 |
| 3.3 | 0.2 | DSK-3R3H204T614-H2L | 6.8×1.4 |
| 2.5 | 0.33 | DS-2R5H334T-HL | 6.8×2.1 |
| 3.3 | 0.33 | DSK-3R3H334T-HL | 6.8×2.1 |

* Soldering conditions are described on page 191.

Standard, Large Capacitance Type Capacitors

GREEN CAP 60°C / 70°C 2.5V / 2.7V

- Pollution-Free ; with no pollutants such as Cd or Pb.
- Unlike batteries ; excellent charge and discharge characteristics with no chemical reactions

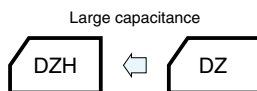

Marking color : White print on a black sleeve

Specifications

| Item | Performance | |
|---|---|---|
| Series name | Series DZ | Series DZH |
| Category temperature range (°C) | -25 to +70 | -25 to +60 |
| Tolerance at rated capacitance (%) | -20 to +80 | -20 to +80 |
| Internal resistance at 1kHz | Refer to the following page | |
| Characteristics at high and low temperature | Percentage of capacitance change | Within ±30% of the value at 20°C |
| | Internal resistance | Less than five times of the value at 20°C |
| Endurance | Test temperature | 70°C |
| | Test time | 1000 hours |
| | Percentage of capacitance change | Within ±30% of the initial measured value |
| | Internal resistance | Less than four times of the initial specified value |
| Shelf life | Same as endurance | |
| Applicable standards | Conforms to JIS C5160-1 2009 (IEC 62391-1 2006) | |

Outline Drawing

Unit : mm

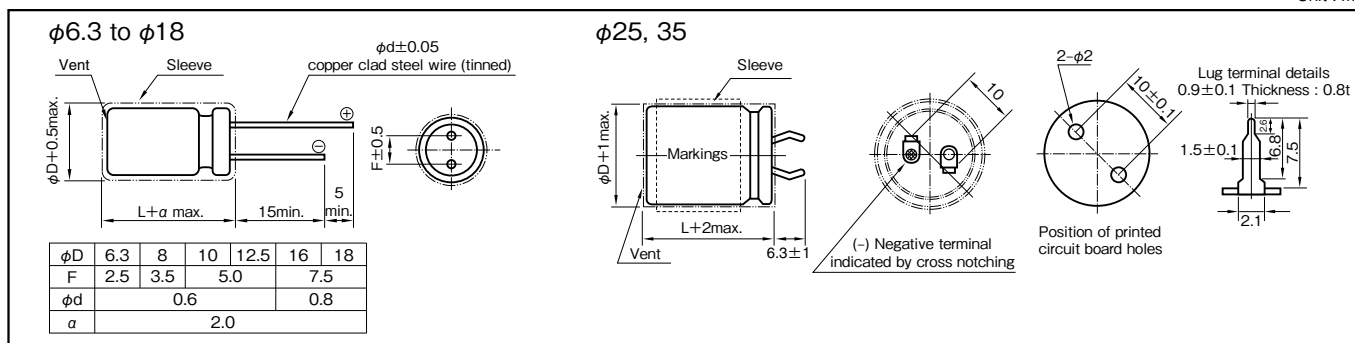

Part numbering system (example : 2.5V10F)

| | | | | | | | |
|-------------|---|-------------------------------|---------------|--------------------------|---------------|---|-------------------------|
| DZ | — | 2R5 | D | 106 | (Z6)(S) | T | □ |
| Series code | | Max. operating voltage symbol | Terminal code | Rated capacitance symbol | Casing symbol | | Taping (Forming) symbol |

Part number is refer to the following page.

Standard Ratings (Series DZ 2.5V)

| Max. operating voltage (V) | Rated capacitance (F) | Max. Leakage Current (mA) after 24h | ELNA Parts No. | φ D×L (mm) | Internal resistance (Ω max.) at 1kHz | Internal resistance (mΩ) at 1kHz (measurement value) |
|----------------------------|-----------------------|-------------------------------------|----------------|------------|--------------------------------------|--|
| 2.5 | 1 | 0.1 | DZ-2R5D105F4T | 6.3×14 | 1.0 | 400 |
| 2.5 | 1 | 0.1 | DZ-2R5D105G3T | 8×12 | 1.0 | 200 |
| 2.5 | 2.7 | 0.2 | DZ-2R5D275G5ST | 8×20 | 0.5 | 150 |
| 2.5 | 3.3 | 0.2 | DZ-2R5D335H5T | 10×20 | 0.3 | 70 |
| 2.5 | 4.7 | 0.3 | DZ-2R5D475H5T | 10×20 | 0.2 | 80 |
| 2.5 | 5.6 | 0.3 | DZ-2R5D565H5T | 10×20 | 0.2 | 70 |
| 2.5 | 6.8 | 0.4 | DZ-2R5D685H6T | 10×25 | 0.2 | 60 |
| 2.5 | 10 | 0.5 | DZ-2R5D106H8T | 10×35 | 0.2 | 40 |
| 2.5 | 10 | 0.5 | DZ-2R5D106Z6ST | 12.5×25 | 0.2 | 40 |
| 2.5 | 15 | 0.7 | DZ-2R5D156Z8ST | 12.5×35 | 0.2 | 35 |
| 2.5 | 15 | 0.7 | DZ-2R5D156J5T | 16×20 | 0.2 | 35 |
| 2.5 | 22 | 0.8 | DZ-2R5D226J6T | 16×25 | 0.2 | 30 |
| 2.5 | 33 | 0.8 | DZ-2R5D336J8T | 16×35.5 | 0.2 | 30 |
| 2.5 | 40 | 0.8 | DZ-2R5D406K9T | 18×40 | 0.2 | 30 |
| 2.5 | 50 | 1.0 | DZ-2R5D506T | 25×40 | 0.08 | 20 |
| 2.5 | 100 | 1.0 | DZ-2R5D107S37T | 25×50 | 0.08 | 15 |
| 2.5 | 200 | 2.0 | DZ-2R5D207S57T | 35×50 | 0.08 | 15 |

We tailor packaged product in series and parallel arrangements according to voltage and capacitance as required.

Standard Ratings (Series DZ 2.7V)

| Max. operating voltage (V) | Rated capacitance (F) | Max. Leakage Current (mA) after 24h | ELNA Parts No. | φ D×L (mm) | Internal resistance (Ω max.) at 1kHz | Internal resistance (mΩ) at 1kHz (measurement value) |
|----------------------------|-----------------------|-------------------------------------|----------------|------------|--------------------------------------|--|
| 2.7 | 1 | 0.2 | DZ-2R7D105F4T | 6.3×14 | 1.0 | 400 |
| 2.7 | 1 | 0.2 | DZ-2R7D105G3T | 8×12 | 1.0 | 200 |
| 2.7 | 2.7 | 0.3 | DZ-2R7D275G5ST | 8×20 | 0.5 | 150 |
| 2.7 | 3.3 | 0.3 | DZ-2R7D335H5T | 10×20 | 0.3 | 70 |
| 2.7 | 4.7 | 0.4 | DZ-2R7D475H5T | 10×20 | 0.2 | 80 |
| 2.7 | 5.6 | 0.4 | DZ-2R7D565H5T | 10×20 | 0.2 | 70 |
| 2.7 | 6.8 | 0.5 | DZ-2R7D685H6T | 10×25 | 0.2 | 60 |
| 2.7 | 10 | 0.6 | DZ-2R7D106H8T | 10×35 | 0.2 | 40 |
| 2.7 | 10 | 0.6 | DZ-2R7D106Z6ST | 12.5×25 | 0.2 | 40 |
| 2.7 | 15 | 0.8 | DZ-2R7D156Z8ST | 12.5×35 | 0.2 | 35 |
| 2.7 | 15 | 0.8 | DZ-2R7D156J6T | 16×25 | 0.2 | 35 |
| 2.7 | 22 | 1.0 | DZ-2R7D226J7T | 16×31.5 | 0.2 | 30 |
| 2.7 | 33 | 1.0 | DZ-2R7D336J9T | 16×40 | 0.2 | 30 |

We tailor packaged product in series and parallel arrangements according to voltage and capacitance as required.

Standard Ratings (Series DZH 2.5V)

| Max. operating voltage (V) | Rated capacitance (F) | Max. Leakage Current (mA) after 24h | ELNA Parts No. | φ D×L (mm) | Internal resistance (Ω max.) at 1kHz | Internal resistance (mΩ) at 1kHz (measurement value) |
|----------------------------|-----------------------|-------------------------------------|-----------------|------------|--------------------------------------|--|
| 2.5 | 22 | 0.8 | DZH-2R5D226Z8ST | 12.5×35 | 0.2 | 55 |
| 2.5 | 50 | 1.0 | DZH-2R5D506K9T | 18×40 | 0.08 | 30 |
| 2.5 | 100 | 2.0 | DZH-2R5D107S35T | 25×40 | 0.08 | 20 |
| 2.5 | 300 | 5.0 | DZH-2R5D307S57T | 35×50 | 0.08 | 15 |

We tailor packaged product in series and parallel arrangements according to voltage and capacitance as required.

High Power Type Capacitors

GREEN CAP 70 °C Low ESR 2.5V / 2.7V

- Low internal resistance allows boosting charge and heavy-current discharge. (ampere level)
- Pollution-Free ; with no pollutants such as Cd or Pb.
- Unlike batteries, excellent charge and discharge characteristics with no chemical reaction

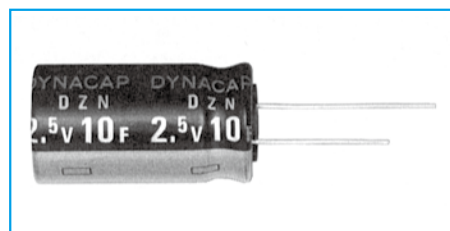
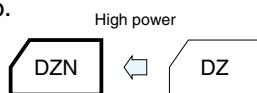

Marking color : White print on a blue sleeve

Specifications

| Item | Performance | |
|---|---|---|
| Category temperature range (°C) | -25 to +70 | |
| Tolerance at rated capacitance (%) | -20 to +80 | |
| Internal resistance at 1 kHz | Refer to the following page | |
| Characteristics at high and low temperature | Percentage of capacitance change | Within ±30% of the value at 20°C |
| | Internal resistance | Less than five times of the value at 20°C |
| Endurance (70°C) | Test time | 1000 hours |
| | Percentage of capacitance change | Within ±30% of the initial measured value |
| | Internal resistance | Less than four times of the initial specified value |
| Shelf life (70°C) | Test time : 1000 hours ; Same as endurance. | |
| Applicable standards | Conforms to JIS C5160-1 2009 (IEC 62391-1 2006) | |

Outline Drawing

Unit : mm

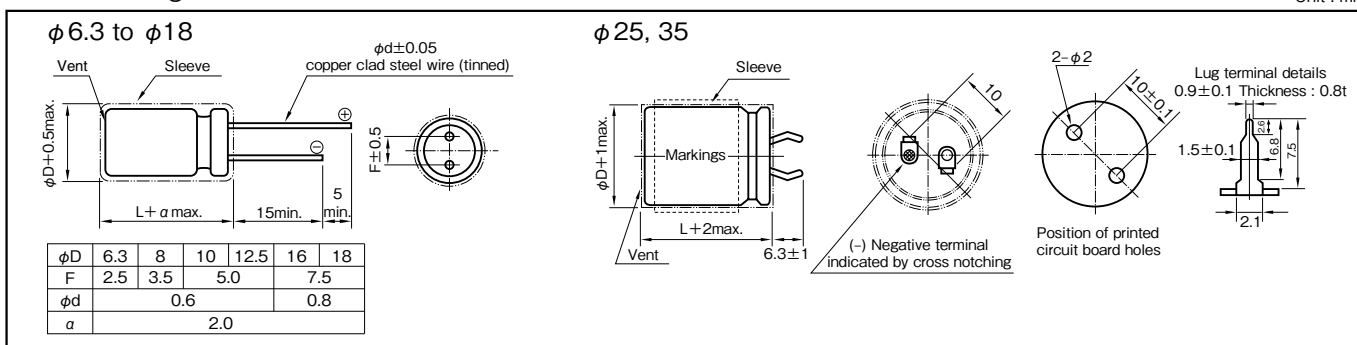

Part numbering system (example : 2.5V10F)

| | | | | | | | | |
|-------------|---|-------------------------------|---------------|--------------------------|---------------|---|---|-------------------------|
| DZN | — | 2R5 | D | 106 | (Z6)(S) | T | — | □ |
| Series code | | Max. operating voltage symbol | Terminal code | Rated capacitance symbol | Casing symbol | | | Taping (Forming) symbol |

Part number is refer to the following page.

Standard Ratings (Series DZN 2.5V)

| Max. operating voltage (V) | Rated capacitance (F) | Max. Leakage Current (mA) after 24h | ELNA Parts No. | φ D×L (mm) | Internal resistance (Ω max.) at 1kHz | Internal resistance (mΩ max.) (DCR) |
|----------------------------|-----------------------|-------------------------------------|-----------------|------------|--------------------------------------|-------------------------------------|
| 2.5 | 1 | 0.1 | DZN-2R5D105F4T | 6.3×14 | 0.4 | 1500 |
| 2.5 | 1 | 0.1 | DZN-2R5D105G3T | 8×12 | 0.3 | 1000 |
| 2.5 | 2.7 | 0.2 | DZN-2R5D275G5ST | 8×20 | 0.3 | 500 |
| 2.5 | 3.3 | 0.2 | DZN-2R5D335H5T | 10×20 | 0.2 | 350 |
| 2.5 | 4.7 | 0.3 | DZN-2R5D475H5T | 10×20 | 0.1 | 400 |
| 2.5 | 5.6 | 0.3 | DZN-2R5D565H5T | 10×20 | 0.1 | 350 |
| 2.5 | 6.8 | 0.4 | DZN-2R5D685H6T | 10×25 | 0.1 | 300 |
| 2.5 | 10 | 0.5 | DZN-2R5D106H8T | 10×35 | 0.1 | 200 |
| 2.5 | 10 | 0.5 | DZN-2R5D106Z6ST | 12.5×25 | 0.1 | 200 |
| 2.5 | 15 | 0.7 | DZN-2R5D156Z8ST | 12.5×35 | 0.1 | 150 |
| 2.5 | 15 | 0.7 | DZN-2R5D156J5T | 16×20 | 0.1 | 150 |
| 2.5 | 22 | 0.8 | DZN-2R5D226J6T | 16×25 | 0.1 | 120 |
| 2.5 | 33 | 0.8 | DZN-2R5D336J8T | 16×35.5 | 0.1 | 100 |
| 2.5 | 40 | 0.8 | DZN-2R5D406K9T | 18×40 | 0.1 | 75 |
| 2.5 | 50 | 1.0 | DZN-2R5D506T | 25×40 | 0.03 | 60 |
| 2.5 | 100 | 1.0 | DZN-2R5D107S37T | 25×50 | 0.03 | 50 |
| 2.5 | 200 | 2.0 | DZN-2R5D207S57T | 35×50 | 0.03 | 40 |

We tailor packaged product in series and parallel arrangements according to voltage and capacitance as required.

Standard Ratings (Series DZN 2.7V)

| Max. operating voltage (V) | Rated capacitance (F) | Max. Leakage Current (mA) after 24h | ELNA Parts No. | φ D×L (mm) | Internal resistance (Ω max.) at 1kHz | Internal resistance (mΩ max.) (DCR) |
|----------------------------|-----------------------|-------------------------------------|-----------------|------------|--------------------------------------|-------------------------------------|
| 2.7 | 1 | 0.2 | DZN-2R7D105F4T | 6.3×14 | 0.4 | 1500 |
| 2.7 | 1 | 0.2 | DZN-2R7D105G3T | 8×12 | 0.3 | 1000 |
| 2.7 | 2.7 | 0.3 | DZN-2R7D275G5ST | 8×20 | 0.3 | 500 |
| 2.7 | 3.3 | 0.3 | DZN-2R7D335H5T | 10×20 | 0.2 | 350 |
| 2.7 | 4.7 | 0.4 | DZN-2R7D475H5T | 10×20 | 0.1 | 400 |
| 2.7 | 5.6 | 0.4 | DZN-2R7D565H5T | 10×20 | 0.1 | 350 |
| 2.7 | 6.8 | 0.5 | DZN-2R7D685H6T | 10×25 | 0.1 | 300 |
| 2.7 | 10 | 0.6 | DZN-2R7D106H8T | 10×35 | 0.1 | 200 |
| 2.7 | 10 | 0.6 | DZN-2R7D106Z6ST | 12.5×25 | 0.1 | 200 |
| 2.7 | 15 | 0.8 | DZN-2R7D156Z8ST | 12.5×35 | 0.1 | 150 |
| 2.7 | 15 | 0.8 | DZN-2R7D156J6T | 16×25 | 0.1 | 150 |
| 2.7 | 22 | 1.0 | DZN-2R7D226J7T | 16×31.5 | 0.1 | 120 |
| 2.7 | 33 | 1.0 | DZN-2R7D336J9T | 16×40 | 0.1 | 100 |

We tailor packaged product in series and parallel arrangements according to voltage and capacitance as required.

High Power, For Low Temperature Type Capacitors

GREEN CAP 65°C 2.7V For -40°C

- For Low Temperature (-40°C).
- Pollution-Free ; with no pollutants such as Cd or Pb.
- Unlike batteries, excellent charge and discharge characteristics with no chemical reaction.

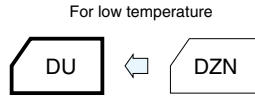

Marking color : White print on a brown sleeve

Specifications

| Item | Performance | |
|---|---|--|
| Category temperature range (°C) | -40 to +65 | |
| Tolerance at rated capacitance (%) | -20 to +80 | |
| Internal resistance at 1 kHz | Refer to the Standard Ratings | |
| Characteristics at high and low temperature | Percentage of capacitance change | Within ±30% of the value at 20°C |
| | Internal resistance | Less than three times of the value at 20°C |
| Endurance (65°C) | Test time | 1000 hours |
| | Percentage of capacitance change | Within ±30% of initial measured value |
| | Internal resistance | Less than three times of the initial specified value |
| Shelf life (65°C) | Test time : 1000 hours ; same as endurance. | |
| Applicable standards | Conforms to JIS C5160-1 2009 (IEC 62391-1 2006) | |

Outline Drawing

Unit : mm

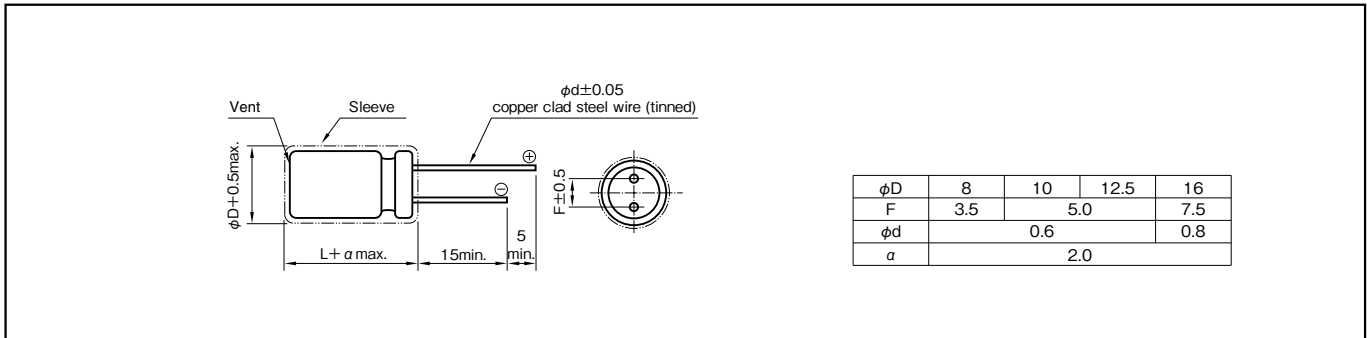

Part numbering system (example : 2.7V10F)

| | | | | | | | | |
|-------------|---|-------------------------------|---------------|--------------------------|---------------|---|---|-------------------------|
| DU | — | 2R7 | D | 106 | H7 | T | — | |
| Series code | | Max. operating voltage symbol | Terminal code | Rated capacitance symbol | Casing symbol | | | Taping (Forming) symbol |

Part number is refer to the following table.

Standard Ratings

| Max. operating voltage (V) | Rated capacitance (F) | Max. Leakage Current (mA) after 24h | ELNA Parts No. | $\phi D \times L$ (mm) | Internal resistance (m Ω max.) at 1kHz | Internal resistance (m Ω max.) (DCR) |
|----------------------------|-----------------------|-------------------------------------|----------------|------------------------|---|---|
| 2.7 | 1 | 0.2 | DU-2R7D105G3T | 8×12 | 250 | 700 |
| 2.7 | 3.3 | 0.3 | DU-2R7D335G5T | 8×20 | 75 | 200 |
| 2.7 | 6.8 | 0.5 | DU-2R7D685H5T | 10×20 | 60 | 120 |
| 2.7 | 10 | 0.6 | DU-2R7D106H7T | 10×30 | 50 | 75 |
| 2.7 | 15 | 0.8 | DU-2R7D156Z6T | 12.5×25 | 35 | 60 |
| 2.7 | 25 | 1.0 | DU-2R7D256J6T | 16×25 | 25 | 42 |
| 2.7 | 33 | 1.0 | DU-2R7D336J7T | 16×31.5 | 20 | 35 |

For Low Temperature Type Capacitors

GREEN CAP

70°C

2.5V

For -40°C

- For Low Temperature (-40°C).
- Pollution-Free ; with no pollutants such as Cd or Pb.
- Unlike batteries, excellent charge and discharge characteristics with no chemical reaction.

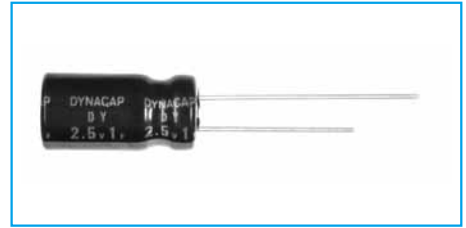
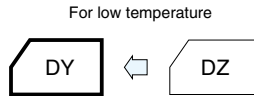

Marking color : White print on a brown sleeve

Specifications

| Item | Performance | | |
|---|---|---|--|
| Category temperature range (°C) | -40 to +70 | | |
| Tolerance at rated capacitance (%) | -20 to +80 | | |
| Internal resistance at 1 kHz | Refer to the Standard Ratings | | |
| Characteristics at high and low temperature | Percentage of capacitance change | -20 to +70°C -40 to <-25°C | Within ±30% of the value at 20°C Within ±50% of the value at 20°C |
| | Internal resistance | -20 to +70°C | Less than five times of the value at 20°C |
| | | -40 to <-25°C | Less than ten times of the value at 20°C |
| | Endurance (70°C) | Test time | 1000 hours |
| Percentage of capacitance change | | Within ±30% of initial measured value | |
| Internal resistance | | Less than four times of the initial specified value | |
| Shelf life (70°C) | Test time : 1000 hours ; Same as endurance. | | |
| Applicable standards | Conforms to JIS C5160-1 2009 (IEC 62391-1 2006) | | |

Outline Drawing

Unit : mm

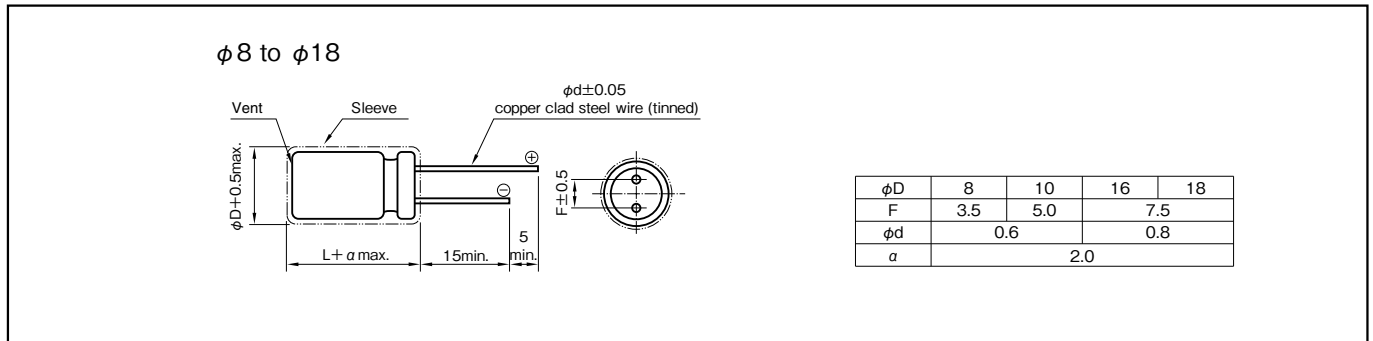

Part numbering system (example : 2.5V10F)

| | | | | | | | |
|-------------|---|-------------------------------|---------------|--------------------------|---------------|---|-------------------------|
| DY | — | 2R5 | D | 106 | (H8)(S) | T | □ |
| Series code | | Max. operating voltage symbol | Terminal code | Rated capacitance symbol | Casing symbol | | Taping (Forming) symbol |

Part number is refer to the following table.

Standard Ratings

| Max. operating voltage (V) | Rated capacitance (F) | Max. Leakage Current (mA) after 24h | ELNA Parts No. | φD×L (mm) | Internal resistance (Ω max.) at 1kHz | Internal resistance (mΩ) at 1kHz (measurement value) |
|----------------------------|-----------------------|-------------------------------------|----------------|-----------|--------------------------------------|--|
| 2.5 | 1 | 0.1 | DY-2R5D105G3T | 8×12 | 1 | 200 |
| 2.5 | 2.7 | 0.2 | DY-2R5D275G5ST | 8×20 | 0.5 | 120 |
| 2.5 | 3.3 | 0.2 | DY-2R5D335H5T | 10×20 | 0.3 | 60 |
| 2.5 | 4.7 | 0.3 | DY-2R5D475H5T | 10×20 | 0.2 | 70 |
| 2.5 | 5.6 | 0.3 | DY-2R5D565H5T | 10×20 | 0.2 | 70 |
| 2.5 | 6.8 | 0.4 | DY-2R5D685H6T | 10×25 | 0.2 | 50 |
| 2.5 | 10 | 0.5 | DY-2R5D106H8T | 10×35 | 0.2 | 35 |
| 2.5 | 10 | 0.5 | DY-2R5D106Z6ST | 12.5×25 | 0.2 | 35 |
| 2.5 | 15 | 0.7 | DY-2R5D156Z8ST | 12.5×35 | 0.2 | 30 |
| 2.5 | 15 | 0.7 | DY-2R5D156J5T | 16×20 | 0.2 | 30 |
| 2.5 | 22 | 0.8 | DY-2R5D226J6T | 16×25 | 0.2 | 25 |
| 2.5 | 33 | 0.8 | DY-2R5D336J8T | 16×35.5 | 0.2 | 25 |
| 2.5 | 40 | 0.8 | DY-2R5D406K9T | 18×40 | 0.2 | 25 |

NOTE : Design, Specifications are subject to change without notice. It is recommended that you shall obtain technical specifications from ELNA to ensure that the component is suitable for your use.

Packed Type Capacitors

GREEN CAP 70°C 5.0V

- High-voltage capacitor which connected DZ in series.
- Pollution-Free ; with no pollutants such as Cd or Pb.
- Unlike batteries, excellent charge and discharge characteristics with no chemical reaction.

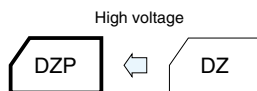

Marking color : White print on a blue sleeve

Specifications

| Item | Performance | |
|---|---|---|
| Category temperature range (°C) | -25 to +70 | |
| Tolerance at rated capacitance (%) | -20 to +80 | |
| Internal resistance at 1 kHz | Refer to the Standard Ratings | |
| Characteristics at high and low temperature | Percentage of capacitance change | Within ±30% of the value at 20°C |
| | Internal resistance | Less than five times of the value at 20°C |
| Endurance (70°C) | Test time | 1000 hours |
| | Percentage of capacitance change | Within ±30% of the initial measured value |
| | Internal resistance | Less than four times of the initial specified value |
| Shelf life (70°C) | Test time : 1000hours ; same as endurance. | |
| Applicable standards | Conforms to JIS C5160-1 2009 (IEC 62391-1 2006) | |

Outline Drawing

Unit : mm

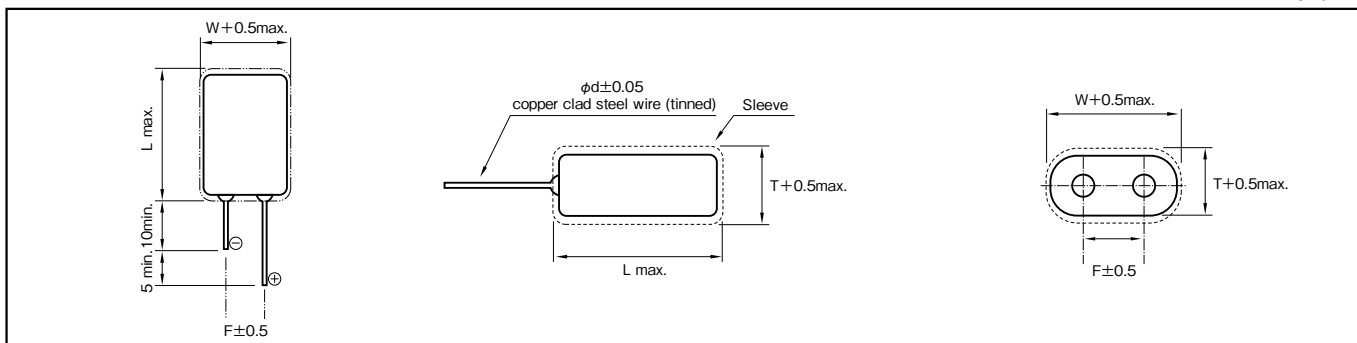

Part numbering system (example : 5.0V0.47F)

| | | | | | | | |
|-------------|---|-------------------------------|---|--------------------------|---------------|---------|-----------------|
| DZP | — | 5 | V | 474 | G3 () | NT (S1) | □ |
| Series code | | Max. operating voltage symbol | | Rated capacitance symbol | Casing symbol | | Additional code |

Part number is refer to the following table.

Standard Ratings

| Max. operating voltage (V) | Rated capacitance (F) | Max. Leakage Current (mA) after 24h | ELNA Parts No. | T×W×L (mm) | φd | F | Internal resistance (Ω max.) at 1kHz | Internal resistance (mΩ) at 1kHz (measurement value) |
|----------------------------|-----------------------|-------------------------------------|------------------|----------------|-----|------|--------------------------------------|--|
| 5.0 | 0.47 | 0.2 | DZP-5V474G3NTS1A | 8.5×17.0×16.0 | 0.6 | 5.1 | 0.6 | 300 |
| | | | DZP-5V474G3NTS1B | | | 12.1 | | |
| 5.0 | 1.0 | 0.3 | DZP-5V105G5SNTA | 8.5×17.0×24.0 | 0.6 | 5.1 | 0.6 | 240 |
| | | | DZP-5V105G5SNTB | | | 12.1 | | |
| 5.0 | 1.5 | 0.4 | DZP-5V155G5SNTA | 8.5×17.0×24.0 | 0.6 | 5.1 | 0.6 | 200 |
| | | | DZP-5V155G5SNTB | | | 12.1 | | |
| 5.0 | 3.3 | 0.8 | DZP-5V335H7NTS1A | 10.5×21.0×34.0 | 0.6 | 5.5 | 0.2 | 80 |
| | | | DZP-5V335H7NTS1B | | | 15.5 | | |
| 5.0 | 4.7 | 1.0 | DZP-5V475H8NTS1A | 10.5×21.0×39.0 | 0.6 | 5.5 | 0.2 | 70 |
| | | | DZP-5V475H8NTS1B | | | 15.5 | | |

NOTE : Design, Specifications are subject to change without notice. It is recommended that you shall obtain technical specifications from ELNA to ensure that the component is suitable for your use.

Large Capacitance, High Power Type Capacitors

GREEN CAP

65 °C

2.7V

- Because it is large capacitance and low resistance, most suitable for such as energy regeneration, and a large current discharge use.
- Pollution-Free ; with no pollutants such as Cd or Pb.
- Unlike batteries, excellent charge and discharge characteristics with no chemical reaction.



Marking color : White print on a black sleeve

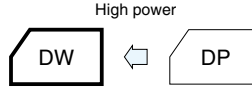

Specifications

| Item | Performance | |
|---|---|--|
| Category temperature range (°C) | -40 to +65 | |
| Tolerance at rated capacitance (%) | 0 to +30 | |
| Internal resistance (DCR) | Refer to the Standard Ratings | |
| Characteristics at high and low temperature | Percentage of capacitance change | Within ±30% of the value at 20°C |
| | Internal resistance (DCR) | Less than three times of the value at 20°C |
| Endurance (65°C) | Test time | 1500 hours |
| | Percentage of capacitance change | Within ±20% of the initial measured value |
| | Internal resistance (DCR) | Less than three times of the initial specified value |
| Shelf life (65°C) | Test time : 1500hours ; same as endurance. | |
| Applicable standards | Conforms to JIS C5160-1 2009 (IEC 62391-1 2006) | |

Outline Drawing

Unit : mm

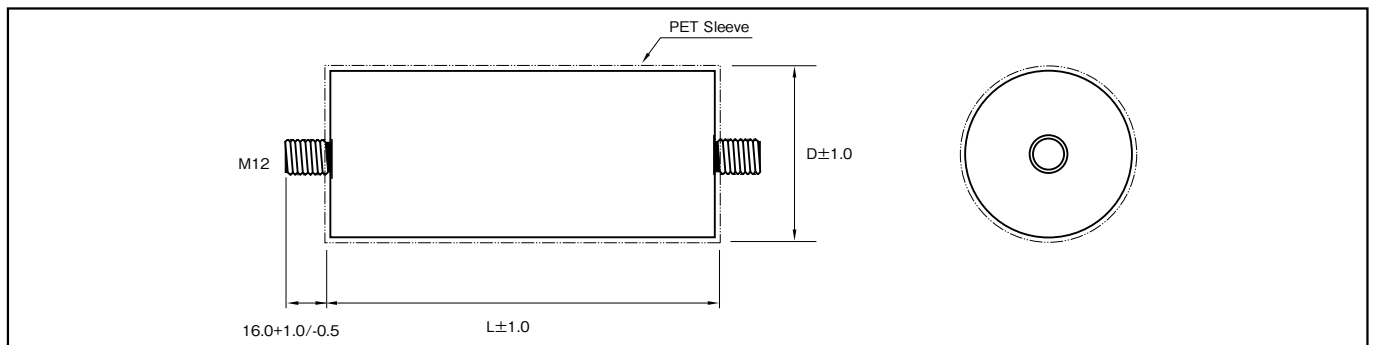

| | | | | | | |
|-------------|---|-------------------------------|---|--------------------------|---------------|---|
| DW | — | 2R7 | D | 308 | DE0 | T |
| Series code | | Max. operating voltage symbol | | Rated capacitance symbol | Casing symbol | |

Part number is refer to the following table.

Standard Ratings

| Max. operating voltage (V) | Rated capacitance (F) | ELNA Parts No. | φD×L (mm) | Internal resistance (mΩ max.) (DCR) |
|----------------------------|-----------------------|----------------|-----------|-------------------------------------|
| 2.7 | 3000 | DW-2R7D308DE0T | 61×138 | 0.29 |

NOTE : Design, Specifications are subject to change without notice. It is recommended that you shall obtain technical specifications from ELNA to ensure that the component is suitable for your use.

Large Capacitance, High Energy Type Capacitors

GREEN CAP

60°C

- Most suitable for energy storage with large capacitance.
- Terminals arranged in the same orientation provide easy connection.
- Unlike batteries, safe and high reliability without containing active and hazardous substances.
- Unlike batteries, excellent charge and discharge characteristics with no chemical reactions.

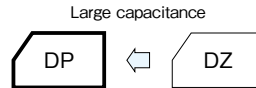

Marking color : White print on a black sleeve

Specifications

| Item | Performance | | | | |
|---|---|---|-----|------|------|
| Category temperature range (°C) | -25 to +60 | | | | |
| Tolerance at rated capacitance (%) | -20 to +20 | | | | |
| Internal resistance at 1 kHz | Rated capacitance (F) | 500 | 600 | 1200 | 1500 |
| | Internal resistance (mΩ Max.) | 12 | 10 | 10 | 10 |
| Characteristics at high and low temperature | Percentage of capacitance change | Within ±30% of value at 20°C | | | |
| | Internal resistance | Less than five times of the value at 20°C | | | |
| Endurance (60°C) | Test time | 2000 hours | | | |
| | Percentage of capacitance change | Within ±30% of the initial measured value | | | |
| | Internal resistance | Less than four times of the initial specified value | | | |
| Shelf life (60°C) | Test time : 2000 hours ; Same as endurance. | | | | |
| Applicable standards | Conforms to JIS C5160-1 2009 (IEC 62391-1 2006) | | | | |

Outline Drawing

Unit : mm

| Capacitance (F) | φD | L | F |
|-----------------|----|-----|------|
| 500 | 35 | 85 | 12.7 |
| 600 | 35 | 105 | 12.7 |
| 1200 | 51 | 105 | 21.8 |
| 1500 | 51 | 120 | 21.8 |

Part numbering system (example : 2.5V600F)

| | | | | | |
|-------------|---|------------------------------|---|--------------------------|---------------|
| DP | — | 2R5 | D | 607 | AA5 |
| Series code | | Max.operating voltage symbol | | Rated capacitance symbol | Casing symbol |

Part number is refer to the following table.

Standard Ratings

| Max. operating voltage (V) | Rated capacitance (F) | ELNA Parts No. | φD×L (mm) | *Internal resistance (mΩ) at 1kHz (measurement value) |
|----------------------------|-----------------------|----------------|-----------|---|
| 2.5 | 500 | DP-2R5D507A85 | 35× 85 | 4.0 |
| 2.5 | 600 | DP-2R5D607AA5 | 35×105 | 3.2 |
| 2.5 | 1200 | DP-2R5D128CA5 | 51×105 | 3.0 |
| 2.5 | 1500 | DP-2R5D158CC0 | 51×120 | 3.0 |

* Internal resistance are not guaranteed values, but measurement value.

We tailor packaged product in series and parallel arrangements according to voltage and capacitance as required.

NOTE : Design, Specifications are subject to change without notice. It is recommended that you shall obtain technical specifications from ELNA to ensure that the component is suitable for your use.

1 Description of Electric Double Layer Capacitor

1-1 Basic Concepts

Generally capacitors are constructed with a dielectric placed between opposed electrodes, functioning as capacitors by accumulating charges in the dielectric material. Aluminum electrolytic and tantalum electrolytic capacitors, for example, use an aluminum oxide film and a tantalum oxide film as the dielectric, respectively.

On the other hand, Electric Double Layer Capacitors have no visible dielectric in a general sense but utilize the state referred to as the electric double layer, which is developed naturally on the interface between substances, as the function of dielectric.

1-2 Operating Principle

The Electric Double Layer represents the state in which positive and negative charges exist at a very short distance on the boundary where contact occurs between two different substances (e.g. solid and liquid). By externally applying a voltage below a certain voltage to the boundary, higher charges can be accumulated. Accordingly, charge and discharge of electric double layer capacitors utilize adsorption and desorption of ions to the ionic adsorption layer (Electric Double Layer) formed on the electrode surface of the activated carbon used for electrodes.

Applying DC voltage externally across the electrodes of the Electric Double Layer allows almost no passage of current up to a certain voltage, exhibiting a condition like insulation.

However, the application of voltages exceeding the certain voltage causes electrolysis to occur in the electrolyte, resulting in abrupt passage of current.

This voltage determines the resistance of voltage of an Electric Double Layer Capacitor. We use an organic electrolyte and its standard electrolysis occurs at the voltage of about 2.5 to 3V.

1-3 Advantages and Disadvantages of Electric Double Layer Capacitor

[Advantages]

- (1) Small size and capacitance in farads (F) available by utilizing the activated carbon electrode with a large surface area
- (2) No special charging circuit and constrains during discharge are required.
- (3) No effect on the life through overcharging and overdischarging
- (4) Environmentally clean energy

[Disadvantage]

- (1) The life is limited due to the use of electrolyte.
- (2) Series connection is required when used with a low resistance of voltage at a high voltage.
- (3) Cannot be used in AC circuits due to high internal resistance unlike aluminum electrolytic capacitors.

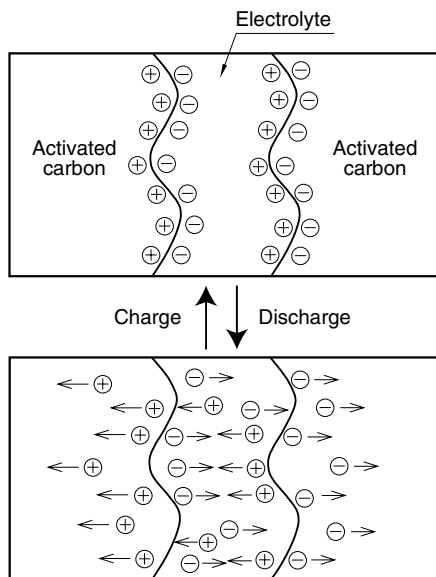

Fig.1 Schematic of Principle of Electric Double Layer Capacitor

1-4 Construction of DYNACAP

The series which consists of coin cells is similar to that of coin-type batteries as shown in Fig.2. DYNACAP contains a single cell or two to three cells stacked in series.

Since these series have a large electrode-to-electrode distance and a small electrode area exhibiting a large internal resistance, they are suitable for the memory backup application that involves microcurrent discharge.

The cylindrical cell construction as seen in the DZ and DZN series has the construction similar to that of aluminum electrolytic capacitors as shown in Fig.3.

These series have a small electrode-to-electrode distance, allowing a large electrode area because of the winding structure. This decreases the internal resistance, which is primary suitable for applications requiring high-power such as motor drive and LED lighting that need high currents.

2 Description of Life Expectancy

Generally, the life of Electric Double Layer Capacitors is largely affected by the ambient temperature.

The expected life is approximated by the equation as shown below:

$$L = L_0 \times 2 \left(\frac{T_0 - T}{10} \right)$$

Where,

- L : Expected lifetime at temperature T
- L₀ : Lifetime at temperature T₀
- T : Expected working temperature
- T₀ : Upper category temperature

Note that the above equation does not cover charge and discharge. In the case of charge and discharge, heat generation occurs inside a capacitor; the temperature rise by this heat generation must also be considered.

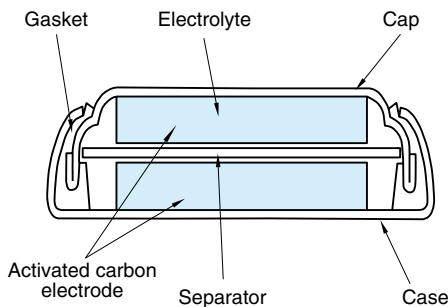

Fig.2 Example of Basic Construction of Coin Cell

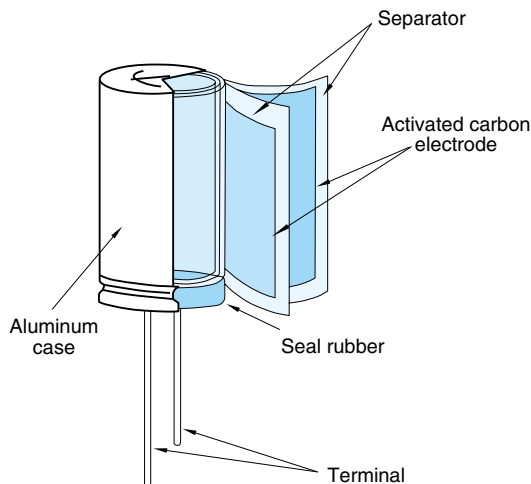

Fig.3 Example of Basic Construction of Cylindrical Cell

3 Calculation Method of Discharge Time

3-1 Approximating the Discharge Time of Basic Constant Current Discharge

The discharge time at the constant current of a capacitor can be calculated by the following equation.

$$t = (C \times \Delta V) / I$$

Where,

- t : Discharge time (sec.)
- C : Capacitor capacitance (F)
- ΔV : Working voltage range (V)
- I : Discharge current (A)

As an example, we calculate the discharge time when a capacitor of the DB series 5.5V 1F is charged with 5V and discharged to 3V at a constant current of 1 mA. Since the working voltage range ΔV is 2V from 5 – 3V, $t = (1F \times 2V) / 0.001A$ from the above equation, and the discharge time can be calculated as 2,000 seconds (about 33 minutes). Note that the actual discharge time may be different because this equation does not cover the effect of the self-discharge and the IR drop by internal resistance described below.

3-2 Effect of Self-discharge at Microcurrents

When backup is made by discharge with a micro-current below some μA especially for the memory backup application and the like, the discharge time must be determined while taking into account the self-discharge as shown in Fig.4.

The value closer to the actual discharge curve is obtained by adding the voltage drop through the self-discharge determined from the voltage retention characteristic test to the discharge curve given by calculation.

Note that the value of self-discharge varies by the charge time, charging current and an ambient temperature.

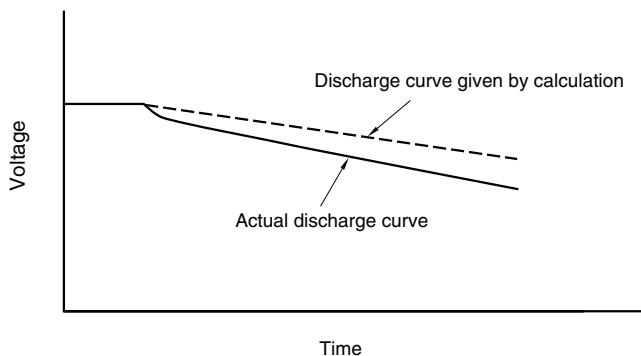

Fig.4 Example of Discharge Curve involving Self-Discharge

3-3 Effect of IR Drop at Large Currents

When a large Current discharge and a capacitor with a high internal resistance are used, the effect of IR drop by the product of the internal resistance and the current must be considered as shown in Fig.5.

When a large current is required in a very short time, or a large instantaneous current flows at the start of discharge, the voltage drop indicated with ΔV1 counts. However, when the discharge continues as it is, the discharge curve indicates in a manner showing a slow diffusion and then keeps a constant straight line.

We also make calculation including ΔV2 of the intersection extending from the initial discharge and the discharge straight line section including the diffusion curve when indicating the DC internal resistance.

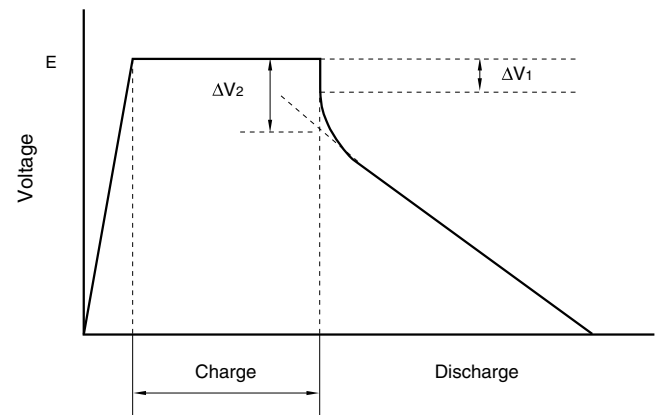

Fig.5 Example of Discharge Curve involving IR Drop

Due to IR drop, the shape of the discharge curve varies by the internal resistance and ambient temperature for each series.

NOTE : Design, Specifications are subject to change without notice. It is recommended that you shall obtain technical specifications from ELNA to ensure that the component is suitable for your use.

4 Series-parallel connection packaged products.

Electric Double Layer Capacitors have a low operating voltage per cell.

To deal with this, ELNA is ready to offer series packaging for high operating voltages to meet to various needs.

Please consult with us on optimization and design.

Packaged item

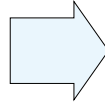

Example of packaged item

In case of a low voltage (up to about 24 V) for the DZ and DZN series with relatively low capacitance, we are preparing simple packaged products.

No full-scale voltage equalization circuit has been equipped yet, but comparatively low cost and flexible layout can be realized.

5 Moisture-proof provision

If a electric double layer capacitor is used in a heat-and-high-humidity environment, the characteristic will deteriorate.

We can improve the durability in heat-and-high-humidity environment by coating of special resin.

Please consult about resin coating.

6 Regarding Recovery Voltage

After charging and then discharging the electric double layer capacitor, and further causing short-circuit to the terminals and leave them alone, the voltage between the two terminals will rise again after some interval. This voltage is called recovery voltage.

This voltage may cause the bad influence to the low-voltage driven components (CPU, memory, etc.) or damage of the capacitor with soldering.

Discharging before use is safer. It is important especially when using it by series connection.

Moreover, it is possible making the terminals in short-circuit condition at the production stage. Please consult us for adequate procedures.

7 Applications

Features & Benefits of Electric Double Layer Capacitor

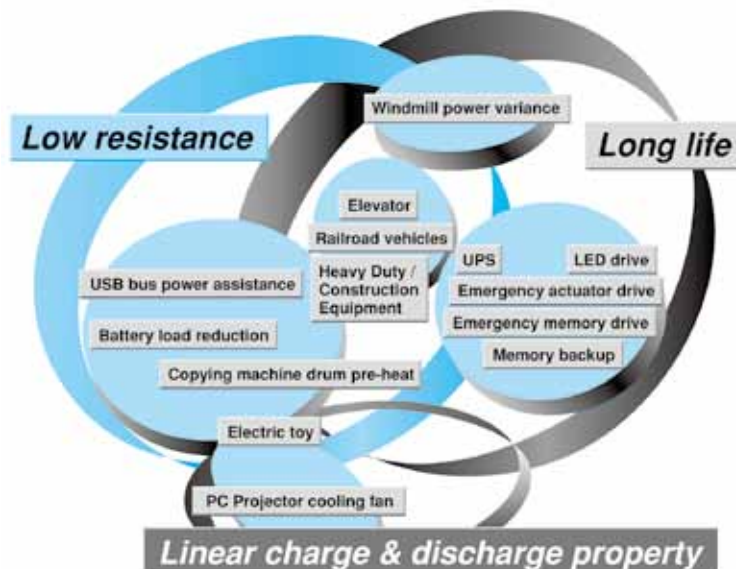

7 Electric Characteristics Data

7-1 Coin type for memory back-up

DYNACAP Series DXJ
5.5V 0.33F/DXJ-5R5H334 φ11.5×5L (mm)

DYNACAP Series DHL
5.5V 0.22F/DHL-5R5D224T φ13.5×9.5L (mm)

■ Endurance (85°C 5.5V.DC)

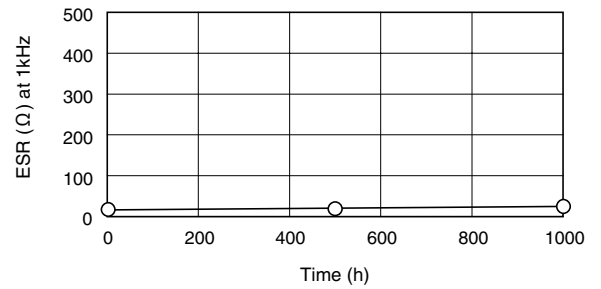
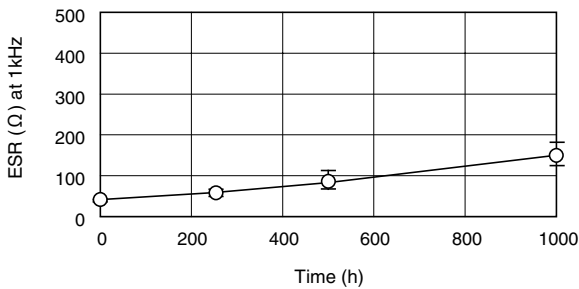
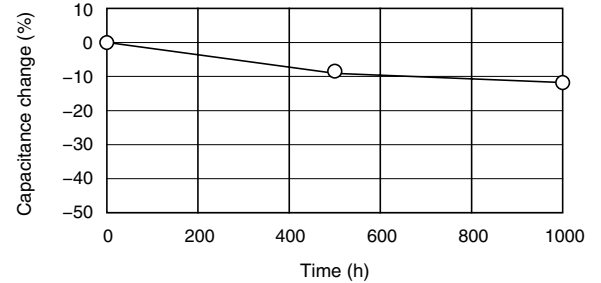
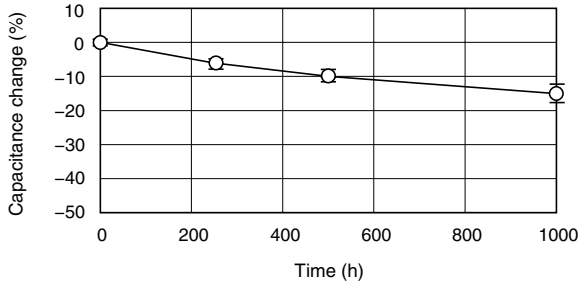

■ Discharge characteristics

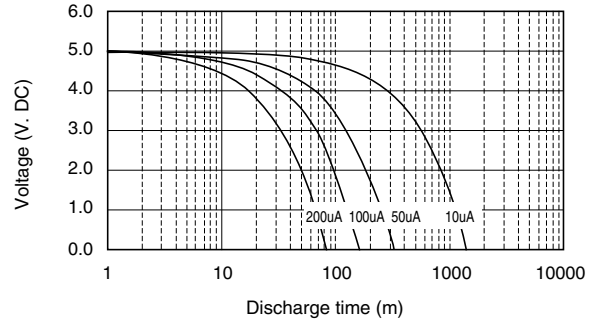
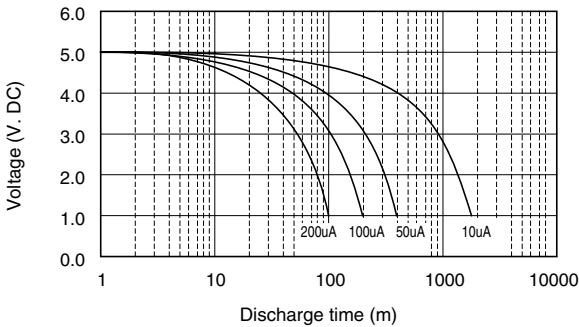

■ Characteristics at high and low temperature

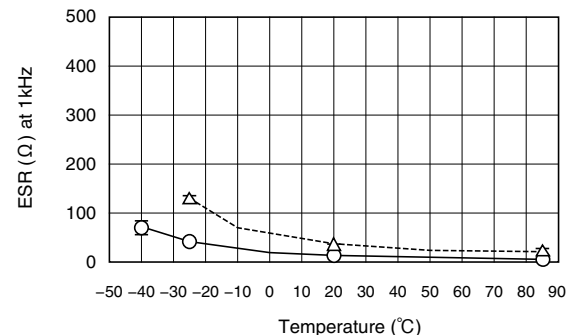
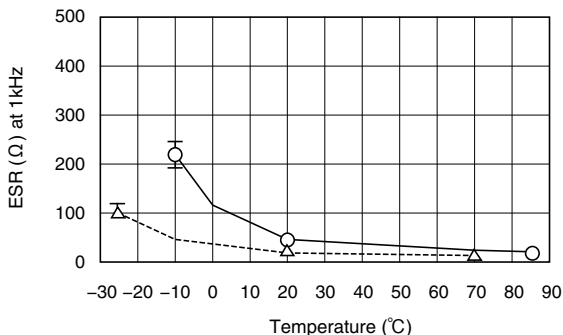
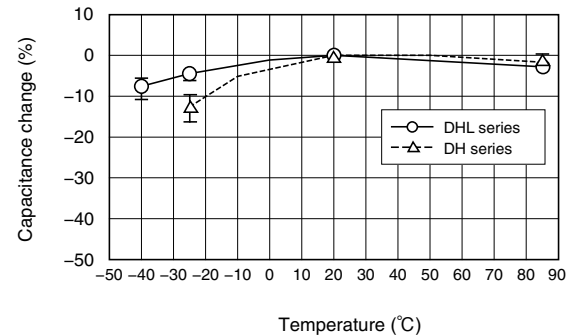
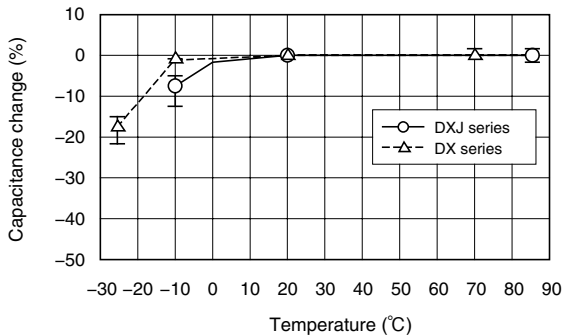

NOTE : Design, Specifications are subject to change without notice.
It is recommended that you shall obtain technical specifications from ELNA to ensure that the component is suitable for your use.

DYNACAP Series DSK
3.3V 0.22F/DSK-3R3H224 $\phi 6.8 \times 2.1L$ (mm)

■ Endurance (60°C 3.3V.DC)

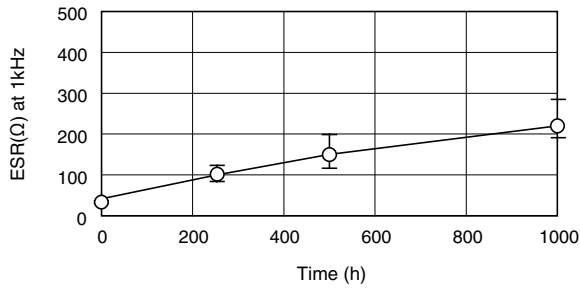
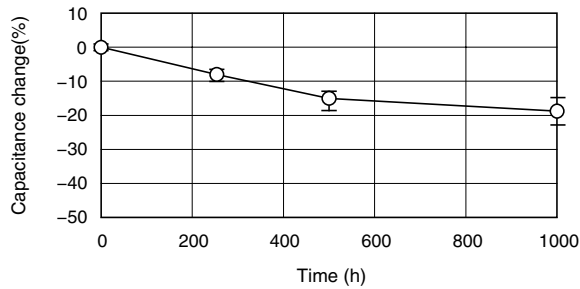

■ Discharge characteristics

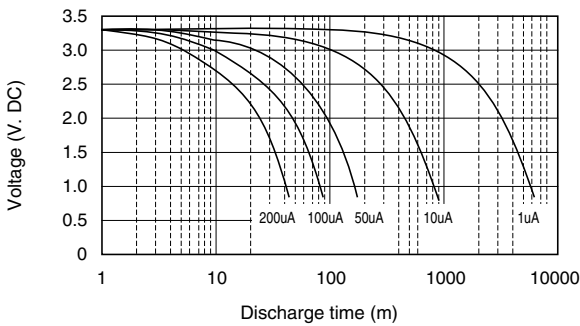

■ Characteristics at high and low temperature

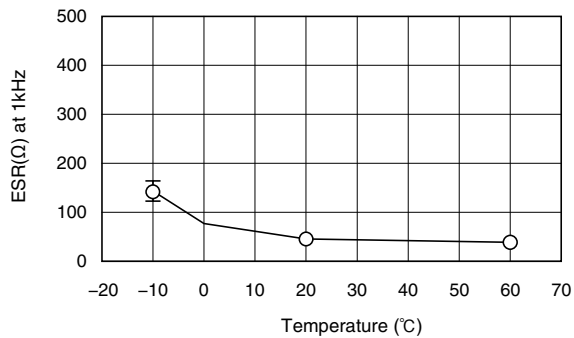
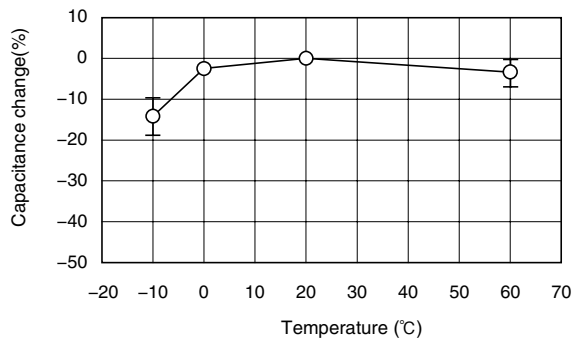

EDLC

7-2 Cylindrical type for power

DYNACAP Series DZN
2.7V 2.7F/DZN-2R7D275G5ST $\phi 8 \times 20L$ (mm)

DYNACAP Series DZN
2.5V 200F/DZN-2R5D207S57T $\phi 35 \times 50L$ (mm)

■ Endurance (70°C 2.7V.DC)

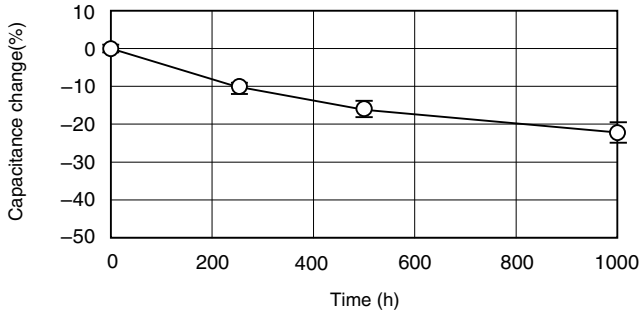

■ Endurance (70°C 2.5V.DC)

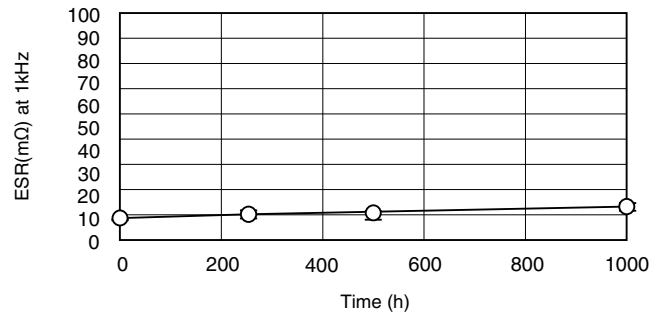
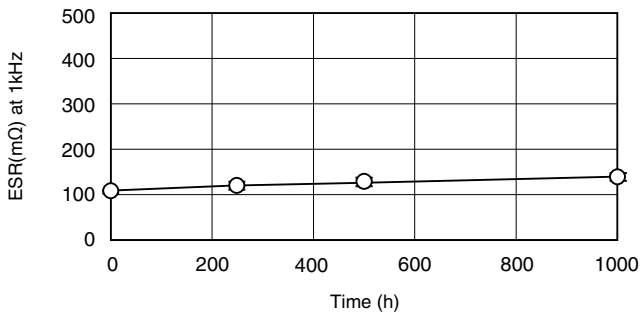
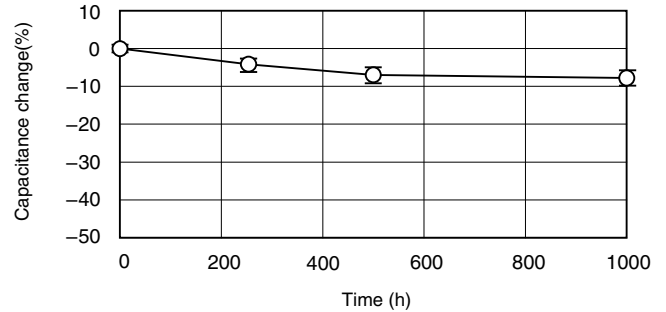

■ Discharge characteristics

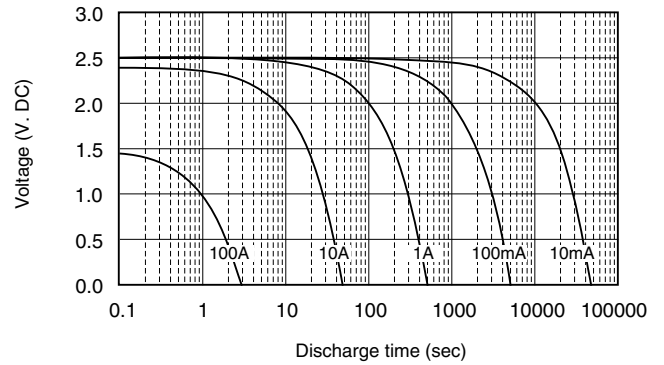
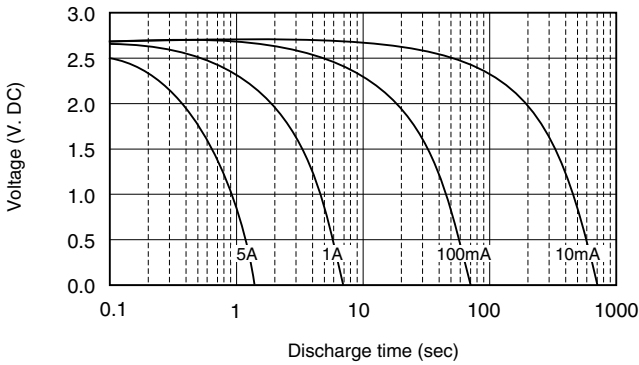

■ Characteristics at high and low temperature

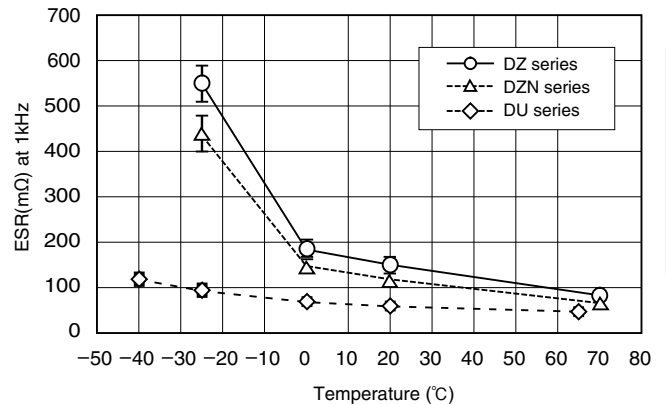
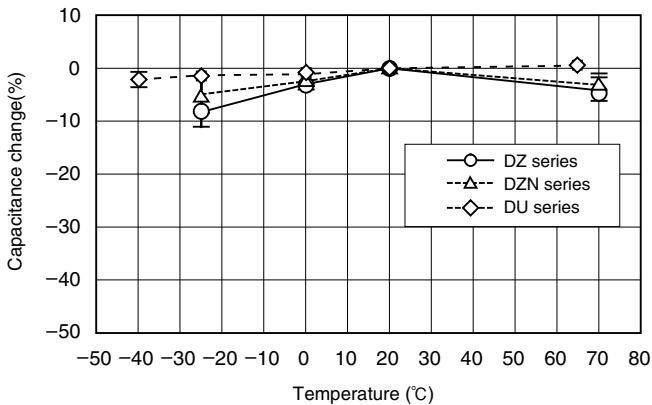

NOTE : Design, Specifications are subject to change without notice.
It is recommended that you shall obtain technical specifications from ELNA to ensure that the component is suitable for your use.

MEMO

ELNA[®]

Plastic Film Capacitors

List of Contents

- 1. Product Symbol System for Plastic Film Capacitors 230
- 2. Cautions for Plastic Film Capacitors 231
- 3. Expected lifetime curve 231
- 4. Specifications for Plastic Film Capacitors by Series 232

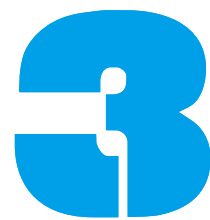

Product Symbol System for Plastic Film Capacitors

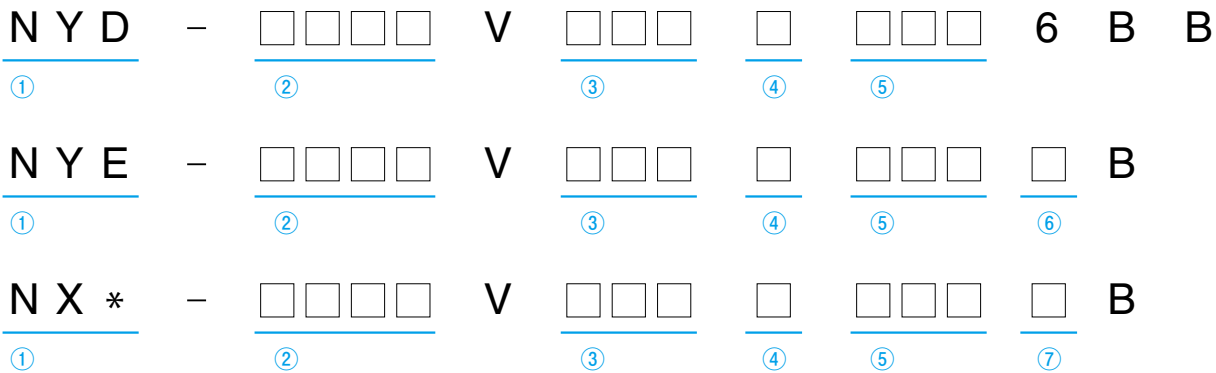

① Series code

Please refer to the page of each series.

② Rated voltage

Please refer to the page of each series.

③ Rated capacitance symbol

Example of series NYD, NYE

| Capacitance (μF) | Capacitance symbol | Capacitance (μF) | Capacitance symbol |
|------------------|--------------------|------------------|--------------------|
| 70 | 700 | 420 | 421 |
| 100 | 101 | 440 | 441 |
| 110 | 111 | 450 | 451 |
| 140 | 141 | 480 | 481 |
| 160 | 161 | 550 | 551 |
| 170 | 171 | 610 | 611 |
| 220 | 221 | 700 | 701 |
| 230 | 231 | 750 | 751 |
| 260 | 261 | 940 | 941 |
| 280 | 281 | 970 | 971 |
| 350 | 351 | 1100 | 112 |
| 400 | 401 | 1500 | 152 |

Example of series NXA, NXB

| Capacitance (μF) | Capacitance symbol | Capacitance (μF) | Capacitance symbol |
|------------------|--------------------|------------------|--------------------|
| 0.15 | 154 | 1.3 | 135 |
| 0.2 | 204 | 1.4 | 145 |
| 0.22 | 224 | 1.5 | 155 |
| 0.3 | 304 | 1.6 | 165 |
| 0.33 | 334 | 1.7 | 175 |
| 0.4 | 404 | 1.8 | 185 |
| 0.45 | 454 | 2 | 205 |
| 0.47 | 474 | 2.2 | 225 |
| 0.55 | 554 | 2.5 | 255 |
| 0.56 | 564 | 2.8 | 285 |
| 0.6 | 604 | 3 | 305 |
| 0.65 | 654 | 3.3 | 335 |
| 0.68 | 684 | 3.5 | 355 |
| 0.7 | 704 | 4 | 405 |
| 0.8 | 804 | 4.2 | 425 |
| 0.82 | 824 | 4.5 | 455 |
| 0.85 | 854 | 4.8 | 485 |
| 1 | 105 | 5 | 505 |
| 1.1 | 115 | 6 | 605 |
| 1.2 | 125 | 7 | 705 |

④ Capacitance tolerance symbol

Example

| Contents | symbol |
|----------|--------|
| ±5% | J |
| ±10% | K |
| ±20% | M |

⑤ Casing symbol

Please refer to the page of each series.

⑦ Shape code

Please refer to the page of each series.

⑥ Terminal code

Please refer to the page of each series.

NOTE : Design, Specifications are subject to change without notice.
It is recommended that you shall obtain technical specifications from ELNA to ensure that the component is suitable for your use.

■ Cautions of Film Capacitors

1. Please do not exceed the specified current.
2. Please confirm voltage waveform and do not exceed the specified voltage.
3. The expected life time changes under the effect of the applied voltage and the inside temperature of the capacitor.

Please refer to the following figure.

Expected life time curve

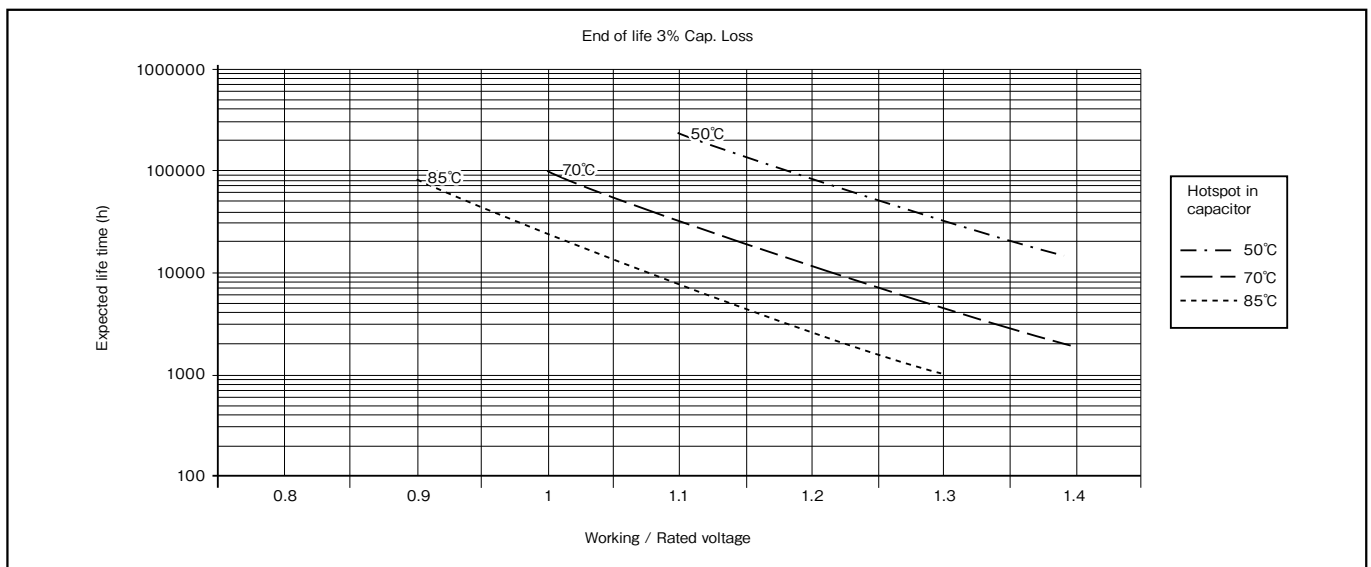

For DC-Link Circuits Capacitors

85°C DC-LINK

- Used in DC-Link circuits, can replace electrolytic capacitor.
- PP film design, good temperature characteristics, stable capacity, low ESR, high ripple current handing capabilities, low Ls, long life.
- Aluminum case, filled with fire-retardant resin.
- Self-healing property.
- Used in Inverters of wind power and solar power, HEV or EV, welders, elevators, Motor Driver systems.



Specifications

| Item | Performance | |
|------------------------------------|---|--|
| Category temperature range (°C) | - 55 to +85 (at Hotspot in capacitor) | |
| Tolerance at rated capacitance (%) | ±5, ±10 (20°C, 50 to 120Hz) | |
| Over Voltage | Rated voltage × 1.1 | 30% of on-load-duration |
| | Rated voltage × 1.15 | 30 min/day |
| | Rated voltage × 1.2 | 5 min/day |
| | Rated voltage × 1.3 | 1 min/day |
| | Rated voltage × 1.5 | 30 ms every time, 100ms/day |
| Dielectric Dissipation Factor | 2×10 ⁻⁴ or less | |
| Life Expectancy | 100000 hours (at Hotspot in capacitor = 70°C) | |
| Failure Rate | 50Fit | |
| Withstanding DC Voltage | Between Terminals | Rated voltage × 1.5 10s |
| | Between Terminals and Case | (2x(Ratef voltage)/√2)+1000 or 3000 VAC whichever is lager 10 s (20°C, 50Hz) |
| Insulation Resistance | 5000MΩ·µF or more (20°C, 100V DC, 1min) | |
| Reference Standard | IEC 61071 | |

Outline Drawing

Unit : mm

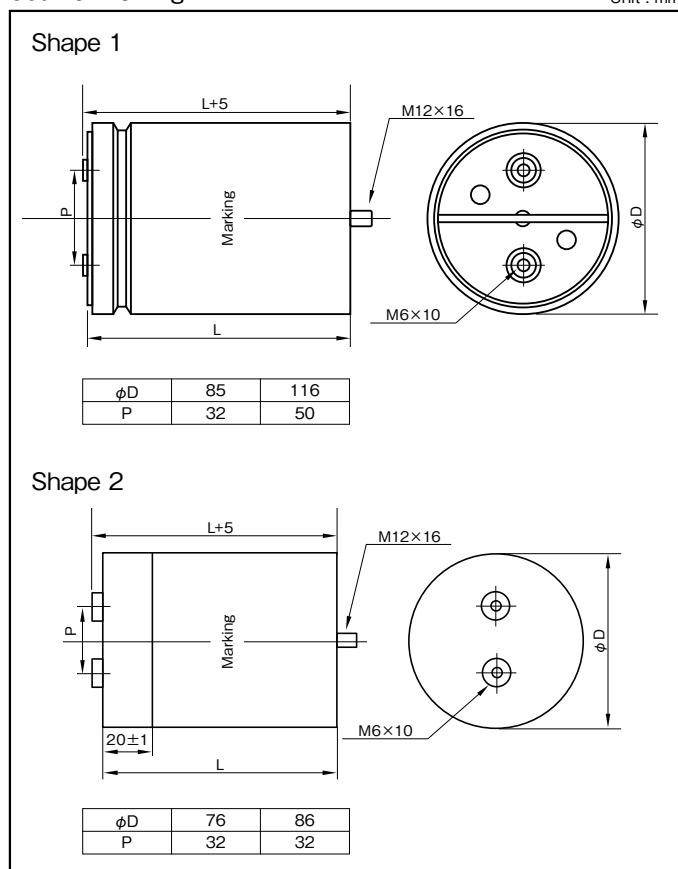

| Part numbering system (example : 1100V420µF) | | | | | |
|--|---|----------------------|--------------------------|------------------------------|----------------------------------|
| NYD | — | 1100 V | 421 | K | F(S)D6 6BB |
| Series code | | Rated voltage symbol | Rated capacitance symbol | Capacitance tolerance symbol | Casing symbol Optional symbol |

Standard Ratings

| Rated voltage (V) | Rated capacitance (μF) | Case (mm) | | Casing symbol | Maximum current (Arms) | Thermal resistance (K/W) | Maximum peak current (A) | Series resistance (mΩ) | Self-inductance (nH) | ELNA Parts No. |
|----------------------|---------------------------|-----------|-----|---------------|---------------------------|-----------------------------|-----------------------------|---------------------------|-------------------------|----------------------|
| | | φD | L | | | | | | | |
| 800 | 350 | 76 | 120 | EC0 | 60 | 4.7 | 3500 | 2.4 | 60 | NYD-800V351*EC06BB |
| | 400 | 76 | 136 | ED6 | 56 | 4.6 | 3600 | 2.8 | 60 | NYD-800V401*ED66BB |
| | 480 | 85 | 120 | FC0 | 61 | 4.7 | 3840 | 2.3 | 60 | NYD-800V481*FC06BB |
| | | 86 | 120 | FSC0 | 61 | 4.7 | 3840 | 2.3 | 60 | NYD-800V481*FSC06BB |
| | 550 | 85 | 136 | FD6 | 58 | 4.6 | 3850 | 2.6 | 60 | NYD-800V551*FD66BB |
| | | 86 | 136 | FSD6 | 58 | 4.6 | 3850 | 2.6 | 60 | NYD-800V551*FSD66BB |
| | 970 | 116 | 120 | HC0 | 69 | 5 | 5820 | 1.7 | 60 | NYD-800V971*HC06BB |
| | 1000 | 85 | 225 | FM5 | 79 | 4 | 6000 | 1.6 | 80 | NYD-800V102*FM56BB |
| | | 86 | 225 | FSM5 | 79 | 4 | 6000 | 1.6 | 80 | NYD-800V102*FSM56BB |
| 1100 | 116 | 136 | HD6 | 67 | 4.9 | 6600 | 1.8 | 60 | NYD-800V112*HD66BB | |
| 1900 | 116 | 230 | HNO | 100 | 2.7 | 11400 | 1.4 | 80 | NYD-800V192*HNO6BB | |
| 900 | 350 | 76 | 120 | EC0 | 54 | 4.7 | 3500 | 2.9 | 60 | NYD-900V351*EC06BB |
| | 400 | 76 | 136 | ED6 | 51 | 4.6 | 3600 | 3.3 | 60 | NYD-900V401*ED66BB |
| | 480 | 85 | 120 | FC0 | 55 | 4.7 | 3840 | 2.8 | 60 | NYD-900V481*FC06BB |
| | | 86 | 120 | FSC0 | 55 | 4.7 | 3840 | 2.8 | 60 | NYD-900V481*FSC06BB |
| | 550 | 85 | 136 | FD6 | 53 | 4.6 | 3850 | 3.1 | 60 | NYD-900V551*FD66BB |
| | | 86 | 136 | FSD6 | 53 | 4.6 | 3850 | 3.1 | 60 | NYD-900V551*FSD66BB |
| | 970 | 116 | 120 | HC0 | 60 | 5 | 5820 | 2.2 | 60 | NYD-900V971*HC06BB |
| | 1000 | 85 | 225 | FM5 | 69 | 4 | 6000 | 2.1 | 80 | NYD-900V102*FM56BB |
| | | 86 | 225 | FSM5 | 69 | 4 | 6000 | 2.1 | 80 | NYD-900V102*FSM56BB |
| 1100 | 116 | 136 | HD6 | 60 | 4.9 | 6600 | 2.3 | 60 | NYD-900V112*HD66BB | |
| 1900 | 116 | 230 | HNO | 88 | 2.7 | 11400 | 1.9 | 80 | NYD-900V192*HNO6BB | |
| 1100 | 170 | 76 | 95 | E95 | 50 | 5.6 | 1700 | 3 | 60 | NYD-1100V171*E956BB |
| | 230 | 76 | 120 | EC0 | 50 | 4.7 | 1840 | 3.4 | 60 | NYD-1100V231*EC06BB |
| | 240 | 85 | 95 | F95 | 56 | 5.1 | 1920 | 2.5 | 60 | NYD-1100V241*F956BB |
| | | 86 | 95 | FS95 | 56 | 5.1 | 1920 | 2.5 | 60 | NYD-1100V241*FS956BB |
| | 260 | 76 | 136 | ED6 | 50 | 4.6 | 2080 | 3.6 | 60 | NYD-1100V261*ED66BB |
| | 310 | 85 | 120 | FC0 | 57 | 4.7 | 2480 | 2.6 | 60 | NYD-1100V311*FC06BB |
| | | 86 | 120 | FSC0 | 57 | 4.7 | 2480 | 2.6 | 60 | NYD-1100V311*FSC06BB |
| | 350 | 76 | 175 | EH5 | 68 | 4.3 | 2800 | 2 | 80 | NYD-1100V351*EH56BB |
| | 420 | 85 | 136 | FD6 | 56 | 4.6 | 3360 | 2.8 | 60 | NYD-1100V421*FD66BB |
| | | 86 | 136 | FSD6 | 56 | 4.6 | 3360 | 2.8 | 60 | NYD-1100V421*FSD66BB |
| | 420 | 85 | 155 | FF5 | 75 | 4.5 | 4200 | 1.6 | 60 | NYD-1100V421*FF56BB |
| | | 86 | 155 | FSF5 | 75 | 4.5 | 4200 | 1.6 | 60 | NYD-1100V421*FSF56BB |
| | 450 | 116 | 95 | H95 | 61 | 5.4 | 4500 | 2 | 60 | NYD-1100V451*H956BB |
| | 480 | 85 | 175 | FH5 | 72 | 4.3 | 4800 | 1.8 | 80 | NYD-1100V481*FH56BB |
| | | 86 | 175 | FSH5 | 72 | 4.3 | 4800 | 1.8 | 80 | NYD-1100V481*FSH56BB |
| | 600 | 85 | 225 | FM5 | 71 | 4 | 6000 | 2 | 80 | NYD-1100V601*FM56BB |
| | | 86 | 225 | FSM5 | 71 | 4 | 6000 | 2 | 80 | NYD-1100V601*FSM56BB |
| | 610 | 116 | 120 | HC0 | 60 | 5 | 4880 | 2.2 | 60 | NYD-1100V611*HC06BB |
| | 680 | 116 | 136 | HD6 | 58 | 4.9 | 5440 | 2.4 | 60 | NYD-1100V681*HD66BB |
| | 940 | 116 | 175 | HH5 | 99 | 3.4 | 8460 | 1.2 | 80 | NYD-1100V941*HH56BB |
| 1100 | 116 | 230 | HNO | 100 | 2.7 | 9900 | 1.3 | 80 | NYD-1100V112*HNO6BB | |
| 1200 | 116 | 230 | HNO | 100 | 2.7 | 10800 | 1.3 | 80 | NYD-1100V122*HNO6BB | |
| 1200 | 220 | 76 | 136 | ED6 | 46 | 4.6 | 2200 | 4.2 | 60 | NYD-1200V221*ED66BB |
| | 300 | 85 | 136 | FD6 | 50 | 4.6 | 3000 | 3.5 | 60 | NYD-1200V301*FD66BB |
| | | 86 | 136 | FSD6 | 50 | 4.6 | 3000 | 3.5 | 60 | NYD-1200V301*FSD66BB |
| | 450 | 116 | 136 | HD6 | 54 | 4.9 | 4050 | 2.8 | 60 | NYD-1200V451*HD66BB |
| | 470 | 86 | 225 | HM5 | 67 | 4 | 4230 | 2.2 | 80 | NYD-1200V471*FSM56BB |
| 1300 | 100 | 76 | 95 | E95 | 46 | 5.6 | 1400 | 3.4 | 60 | NYD-1300V101*E956BB |
| | 160 | 76 | 120 | EC0 | 50 | 4.7 | 1920 | 3.6 | 60 | NYD-1300V161*EC06BB |
| | | 85 | 95 | F95 | 53 | 5.1 | 2240 | 2.8 | 60 | NYD-1300V161*F956BB |
| | 160 | 86 | 95 | FS95 | 53 | 5.1 | 2240 | 2.8 | 60 | NYD-1300V161*FS956BB |
| | | 85 | 120 | FC0 | 53 | 4.7 | 2640 | 3 | 60 | NYD-1300V221*FC06BB |
| | 220 | 86 | 120 | FSC0 | 53 | 4.7 | 2640 | 3 | 60 | NYD-1300V221*FSC06BB |
| | | 116 | 95 | H95 | 58 | 5.4 | 3720 | 2.2 | 60 | NYD-1300V311*H956BB |
| | 310 | 85 | 175 | FH5 | 45 | 4.3 | 3720 | 4.9 | 60 | NYD-1300V311*FH56BB |
| | | 86 | 175 | FSH5 | 45 | 4.3 | 3720 | 4.9 | 60 | NYD-1300V311*FSH56BB |
| | 420 | 116 | 120 | HC0 | 57 | 5 | 4200 | 2.5 | 60 | NYD-1300V421*HC06BB |
| | 470 | 85 | 225 | FM5 | 65 | 4 | 4700 | 2.4 | 80 | NYD-1300V471*FM56BB |
| | | 86 | 225 | FSM5 | 65 | 4 | 4700 | 2.4 | 80 | NYD-1300V471*FSM56BB |
| | 620 | 116 | 175 | HH5 | 92 | 3.4 | 5580 | 1.4 | 80 | NYD-1300V621*HH56BB |
| 800 | 116 | 230 | HNO | 95 | 2.7 | 6400 | 1.5 | 80 | NYD-1300V801*HNO6BB | |
| 1500 | 400 | 116 | 155 | HF5 | 85 | 4.3 | 4000 | 1.3 | 60 | NYD-1500V401*HF56BB |

(Note) * : If tolerance at rated capacitance is 5% = J, 10% = K
 Maximum permissible Ripple current at the ambient temperature of 40°C.
 The thermal Resistance from hotspot to ambient environment.(Natural cooling)

For DC-Link Circuits Capacitors 85°C DC-LINK

- Used in DC-Link circuits, can replace electrolytic capacitor.
- PP film design, good temperature characteristics, stable capacity, low ESR, high ripple current handing capabilities, low Ls, long life.
- Plastic case , filled with fire-retardant resin.
- Self-healing property.
- Used in Inverters of wind power and solar power, welders, elevators, Motor Driver systems.



Specifications

| Item | Performance | |
|------------------------------------|---|--|
| Category temperature range (°C) | - 40 to +85 (at Hotspot in capacitor) | |
| Tolerance at rated capacitance (%) | ±5, ±10 (20°C, 50 to 120Hz) | |
| Over Voltage | Rated voltage × 1.1 | 30% of on-load-duration |
| | Rated voltage × 1.15 | 30 min/day |
| | Rated voltage × 1.2 | 5 min/day |
| | Rated voltage × 1.3 | 1 min/day |
| | Rated voltage × 1.5 | 30 ms every time, 100ms/day |
| Dielectric Dissipation Factor | 2×10 ⁻⁴ or less | |
| Life Expectancy | 100000 hours (at Hotspot in capacitor = 70°C) | |
| Failure Rate | 50Fit | |
| Withstanding DC Voltage | Between Terminals | Rated voltage × 1.5 VDC 10 s |
| | Between Terminals and Case | (2x(Ratef voltage)/√2)+1000 or 3000 VAC whichever is lager 10 s (20°C, 50Hz) |
| Insulation Resistance | 5000MΩ·µF or more (20°C, 100V DC, 1min) | |
| Reference Standard | IEC 61071 | |

Outline Drawing

Unit : mm

Shape 1 (Terminal code Y)

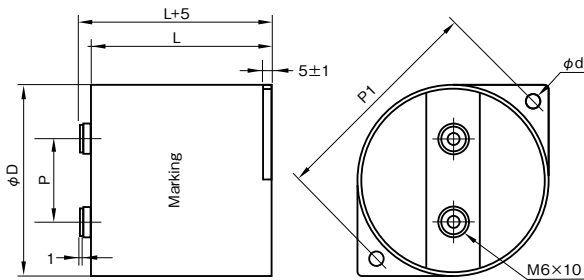

Shape 2 (Terminal code N)

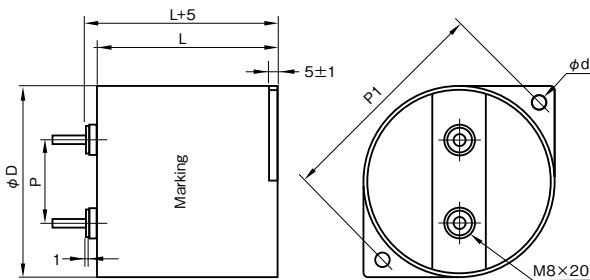

| | | |
|----|-----|-----|
| φD | 85 | 85 |
| L | 65 | 51 |
| P | 45 | 45 |
| P1 | 101 | 101 |
| φd | 5.5 | 5.5 |

Part numbering system (example : 1000V420µF)

| | | | | | | | | |
|-------------|---|----------------------|---|--------------------------|------------------------------|---------------|---------------|-----------------|
| NYE | — | 1100 | V | 111 | K | F65 | Y | B |
| Series code | | Rated voltage symbol | | Rated capacitance symbol | Capacitance tolerance symbol | Casing symbol | Terminal code | Optional symbol |

NOTE : Design, Specifications are subject to change without notice.
It is recommended that you shall obtain technical specifications from ELNA to ensure that the component is suitable for your use.

Standard Ratings

| Rated voltage (V) | Rated capacitance (μF) | Case (mm) | | Casing symbol | Maximum current (Arms) | Thermal resistance (K/W) | Maximum peak current (A) | Series resistance (mΩ) | Self-inductance (nH) | ELNA Parts No. |
|----------------------|---------------------------|-----------|----|---------------|---------------------------|-----------------------------|-----------------------------|---------------------------|-------------------------|--------------------|
| | | φD | L | | | | | | | |
| 600 | 200 | 85 | 51 | F51 | 55 | 4.2 | 4000 | 1.2 | 20 | NYE-600V201*F51□B |
| | 280 | 85 | 65 | F65 | 65 | 5.5 | 3700 | 1.4 | 30 | NYE-600V281*F65□B |
| 800 | 120 | 85 | 51 | F51 | 55 | 4.2 | 3000 | 1.2 | 20 | NYE-800V121*F51□B |
| | 220 | 85 | 65 | F65 | 65 | 5.5 | 3000 | 1.4 | 30 | NYE-800V221*F65□B |
| 1000 | 75 | 85 | 51 | F51 | 50 | 4.2 | 2400 | 1.4 | 20 | NYE-1000V750*F51□B |
| | 110 | 85 | 65 | F65 | 60 | 5.5 | 2300 | 1.7 | 30 | NYE-1000V111*F65□B |
| 1200 | 50 | 85 | 51 | F51 | 50 | 4.2 | 2000 | 1.6 | 20 | NYE-1200V500*F51□B |
| | 80 | 85 | 65 | F65 | 60 | 5.5 | 2000 | 2.0 | 30 | NYE-1200V800*F65□B |

(Note) * : If tolerance at rated capacitance is 5% = J, 10% = K

□ : Terminal code

Maximum permissible Ripple current at the ambient temperature of 40°C .

The thermal Resistance from hotspot to ambient environment.(Natural cooling)

For High-frequency Circuits Capacitors

85 °C High frequency

- Widely used in high voltage, high frequency circuit.
- Low loss and small inherent temperature rise.
- Excellent active and passive flame resistant circuit.
- Especially designed as snubber capacitor for IGBT.

Specifications

| Item | Performance |
|------------------------------------|---|
| Category temperature range (°C) | -40 to +85 (at Hotspot in capacitor) |
| Tolerance at rated capacitance (%) | ±5, ±10 (20°C, 50 to 120Hz) |
| Dielectric Dissipation Factor | 2×10 ⁻⁴ or less |
| Life Expectancy | 100000 hours (at Hotspot in capacitor = 70°C) |
| Failure Rate | 100Fit |
| Withstanding DC Voltage | Between Terminals |
| | Between Terminals and Case |
| Insulation Resistance | 3000MΩ·μF or more (20°C, 100V DC, 1min) |
| Reference Standard | IEC 61071 |

Outline Drawing

Unit : mm

| W | | H | | T | |
|------|------|------|------|------|------|
| Size | Code | Size | Code | Size | Code |
| 42.5 | A | 25.5 | A | 14 | A |
| 43 | B | 28 | B | 24 | B |
| 57.5 | C | 32 | C | 25.5 | C |
| | | 33 | D | 29.5 | D |
| | | 35.5 | E | 30 | E |
| | | 36 | F | 33 | F |
| | | 43 | G | 33.5 | G |
| | | 43.5 | H | 35 | H |
| | | 45 | J | 40 | J |
| | | 50 | K | 42 | K |
| | | 55 | L | 45 | L |

(Note) Tolerance at size : ±1.0

Part numbering system (example : 1200V2.2μF)

| | | | | | | | |
|-------------|---|----------------------|--------------------------|------------------------------|---------------|------------|-----------------|
| NXA | — | 1200 V | 225 | K | CHD | A | B |
| Series code | | Rated voltage symbol | Rated capacitance symbol | Capacitance tolerance symbol | Casing symbol | Shape code | Optional symbol |

Standard Ratings

| Rated voltage (V) | Rated capacitance (µF) | Case (mm) | | | Casing symbol | dV / dt (V/µS) | Peak current (A) | ESR (mΩ Max.) | I rms (A) | Self-inductance (nH) | ELNA Parts No. |
|----------------------|---------------------------|-----------|------|------|---------------|-------------------|---------------------|------------------|--------------|-------------------------|--------------------|
| | | W | H | T | | | | | | | |
| 630VDC (330VAC) | 1 | 42.5 | 28 | 14 | ABA | 100 | 100 | 12 | 7.5 | 20 | NXA-630V105*ABA□B |
| | 1.2 | 42.5 | 32 | 14 | ACA | 100 | 120 | 11 | 9.4 | 20 | NXA-630V125*ACA□B |
| | 1.5 | 42.5 | 25.5 | 25.5 | AAC | 100 | 150 | 10 | 11 | 20 | NXA-630V155*AA□B |
| | 2 | 42.5 | 28 | 24 | ABB | 100 | 200 | 8 | 12.6 | 20 | NXA-630V205*ABB□B |
| | 3 | 42.5 | 36 | 24 | AFB | 100 | 300 | 7 | 17.2 | 20 | NXA-630V305*AFB□B |
| | 3.5 | 42.5 | 33 | 33 | ADF | 100 | 350 | 6 | 19.2 | 20 | NXA-630V355*ADF□B |
| | 4 | 42.5 | 35.5 | 33.5 | AEG | 100 | 400 | 5 | 20.5 | 20 | NXA-630V405*AEG□B |
| 700VDC (380VAC) | 4.5 | 42.5 | 45 | 30 | AJE | 100 | 450 | 4 | 23 | 20 | NXA-630V455*AJE□B |
| | 7 | 42.5 | 43 | 42 | AGK | 100 | 700 | 3 | 28 | 20 | NXA-630V705*AGK□B |
| | 0.8 | 42.5 | 28 | 14 | ABA | 132 | 105.6 | 12 | 7.2 | 20 | NXA-700V804*ABA□B |
| | 1 | 42.5 | 32 | 14 | ACA | 132 | 132 | 12 | 9.2 | 20 | NXA-700V105*ACA□B |
| | 1.2 | 42.5 | 25.5 | 25.5 | AAC | 132 | 158.4 | 10 | 10.8 | 20 | NXA-700V125*AA□B |
| | 1.6 | 42.5 | 28 | 24 | ABB | 132 | 211.2 | 10 | 12.4 | 20 | NXA-700V165*ABB□B |
| | 2.5 | 42.5 | 36 | 24 | AFB | 132 | 330 | 8 | 16.8 | 20 | NXA-700V255*AFB□B |
| 850VDC (450VAC) | 3 | 42.5 | 33 | 33 | ADF | 132 | 396 | 7 | 18.8 | 20 | NXA-700V305*ADF□B |
| | 3.5 | 42.5 | 35.5 | 33.5 | AEG | 132 | 462 | 6 | 20.3 | 20 | NXA-700V355*AEG□B |
| | 4 | 42.5 | 45 | 30 | AJE | 132 | 528 | 5 | 22.4 | 20 | NXA-700V405*AJE□B |
| | 6 | 42.5 | 43 | 42 | AGK | 132 | 792 | 4 | 25 | 20 | NXA-700V605*AGK□B |
| | 0.7 | 42.5 | 28 | 14 | ABA | 200 | 140 | 12 | 6.4 | 20 | NXA-850V704*ABA□B |
| | 0.8 | 42.5 | 32 | 14 | ACA | 200 | 160 | 12 | 8.8 | 20 | NXA-850V804*ACA□B |
| | 1 | 42.5 | 25.5 | 25.5 | AAC | 200 | 200 | 10 | 10.4 | 20 | NXA-850V105*AA□B |
| 1000VDC (480VAC) | 1.2 | 42.5 | 28 | 24 | ABB | 200 | 240 | 10 | 11.8 | 20 | NXA-850V125*ABB□B |
| | 2 | 42.5 | 36 | 24 | AFB | 200 | 400 | 9 | 15.8 | 20 | NXA-850V205*AFB□B |
| | 2.5 | 42.5 | 33 | 33 | ADF | 200 | 500 | 8 | 17.6 | 20 | NXA-850V255*ADF□B |
| | 2.8 | 42.5 | 35.5 | 33.5 | AEG | 200 | 560 | 7 | 19.8 | 20 | NXA-850V285*AEG□B |
| | 3.3 | 42.5 | 45 | 30 | AJE | 200 | 660 | 6 | 21.5 | 20 | NXA-850V335*AJE□B |
| | 4 | 42.5 | 43 | 42 | AGK | 200 | 800 | 5 | 24 | 20 | NXA-850V405*AGK□B |
| | 0.47 | 42.5 | 28 | 14 | ABA | 225 | 105.75 | 12 | 6.2 | 20 | NXA-1000V474*ABA□B |
| 1200VDC (500VAC) | 0.56 | 42.5 | 32 | 14 | ACA | 225 | 126 | 12 | 8.6 | 20 | NXA-1000V564*ACA□B |
| | 0.82 | 42.5 | 25.5 | 25.5 | AAC | 225 | 184.5 | 10 | 9.8 | 20 | NXA-1000V824*AA□B |
| | 1 | 42.5 | 28 | 24 | ABB | 225 | 225 | 10 | 11.6 | 20 | NXA-1000V105*ABB□B |
| | 1.5 | 42.5 | 36 | 24 | AFB | 225 | 337.5 | 9 | 15.5 | 20 | NXA-1000V155*AFB□B |
| | 1.8 | 42.5 | 33 | 33 | ADF | 225 | 405 | 8 | 17.5 | 20 | NXA-1000V185*ADF□B |
| | 2 | 42.5 | 35.5 | 33.5 | AEG | 225 | 450 | 7 | 18.8 | 20 | NXA-1000V205*AEG□B |
| | 2.5 | 42.5 | 45 | 30 | AJE | 225 | 562.5 | 6 | 21 | 20 | NXA-1000V255*AJE□B |
| | 3 | 42.5 | 43 | 42 | AGK | 225 | 675 | 5 | 23 | 20 | NXA-1000V305*AGK□B |
| | 3.3 | 57.5 | 43.5 | 29.5 | CHD | 130 | 429 | 6 | 23 | 20 | NXA-1000V335*CHD□B |
| | 3.5 | 57.5 | 45 | 30 | CJE | 130 | 455 | 5 | 24 | 20 | NXA-1000V355*CJE□B |
| | 4.2 | 57.5 | 45 | 35 | CJH | 130 | 546 | 5 | 24 | 20 | NXA-1000V425*CJH□B |
| | 4.8 | 57.5 | 50 | 35 | CKH | 130 | 624 | 4 | 25 | 20 | NXA-1000V485*CKH□B |
| | 5 | 57.5 | 45 | 45 | CJL | 130 | 650 | 4 | 25 | 20 | NXA-1000V505*CJL□B |
| | 6 | 57.5 | 55 | 40 | CLJ | 130 | 780 | 4 | 28 | 20 | NXA-1000V605*CLJ□B |
| 1600VDC (550VAC) | 0.33 | 42.5 | 28 | 14 | ABA | 225 | 74.25 | 12 | 6 | 20 | NXA-1200V334*ABA□B |
| | 0.4 | 42.5 | 32 | 14 | ACA | 225 | 90 | 12 | 8.5 | 20 | NXA-1200V404*ACA□B |
| | 0.56 | 42.5 | 25.5 | 25.5 | AAC | 225 | 126 | 11 | 9.6 | 20 | NXA-1200V564*AA□B |
| | 0.68 | 42.5 | 28 | 24 | ABB | 225 | 153 | 10 | 11.5 | 20 | NXA-1200V684*ABB□B |
| | 1 | 42.5 | 36 | 24 | AFB | 225 | 225 | 10 | 15.4 | 20 | NXA-1200V105*AFB□B |
| | 1.1 | 42.5 | 33 | 33 | ADF | 225 | 247.5 | 9 | 17.2 | 20 | NXA-1200V115*ADF□B |
| | 1.3 | 42.5 | 35.5 | 33.5 | AEG | 225 | 292.5 | 8 | 18.6 | 20 | NXA-1200V135*AEG□B |
| | 1.6 | 42.5 | 45 | 30 | AJE | 225 | 360 | 7 | 20.6 | 20 | NXA-1200V165*AJE□B |
| | 2 | 42.5 | 43 | 42 | AGK | 225 | 450 | 6 | 22 | 20 | NXA-1200V205*AGK□B |
| | 2.2 | 57.5 | 43.5 | 29.5 | CHD | 150 | 330 | 6 | 22 | 20 | NXA-1200V225*CHD□B |
| | 2.5 | 57.5 | 45 | 30 | CJE | 150 | 375 | 6 | 23 | 20 | NXA-1200V255*CJE□B |
| | 2.8 | 57.5 | 45 | 35 | CJH | 150 | 420 | 5 | 24 | 20 | NXA-1200V285*CJH□B |
| | 3.3 | 57.5 | 50 | 35 | CKH | 150 | 495 | 5 | 24 | 20 | NXA-1200V335*CKH□B |
| | 3.5 | 57.5 | 45 | 45 | CJL | 150 | 525 | 4 | 25 | 20 | NXA-1200V355*CJL□B |
| 4 | 57.5 | 55 | 40 | CLJ | 150 | 600 | 4 | 26 | 20 | NXA-1200V405*CLJ□B | |
| 1600VDC (550VAC) | 0.2 | 42.5 | 28 | 14 | ABA | 225 | 45 | 12 | 6 | 20 | NXA-1600V204*ABA□B |
| | 0.22 | 42.5 | 32 | 14 | ACA | 225 | 49.5 | 12 | 8.4 | 20 | NXA-1600V224*ACA□B |
| | 0.33 | 42.5 | 25.5 | 25.5 | AAC | 225 | 74.25 | 11 | 9.5 | 20 | NXA-1600V334*AA□B |
| | 0.45 | 42.5 | 28 | 24 | ABB | 225 | 101.25 | 11 | 11.4 | 20 | NXA-1600V454*ABB□B |
| | 0.6 | 42.5 | 36 | 24 | AFB | 225 | 135 | 10 | 15.2 | 20 | NXA-1600V604*AFB□B |
| | 0.7 | 43 | 33 | 33 | BDF | 225 | 157.5 | 10 | 17 | 20 | NXA-1600V704*BDF□B |
| | 0.85 | 43 | 35.5 | 33.5 | BEG | 225 | 191.25 | 9 | 18.4 | 20 | NXA-1600V854*BEG□B |
| | 1 | 42.5 | 45 | 30 | AJE | 225 | 225 | 8 | 20.5 | 20 | NXA-1600V105*AJE□B |
| | 1.3 | 42.5 | 43 | 42 | AGK | 225 | 292.5 | 7 | 21 | 20 | NXA-1600V135*AGK□B |
| | 1.5 | 57.5 | 43.5 | 29.5 | CHD | 150 | 225 | 6 | 22 | 20 | NXA-1600V155*CHD□B |
| | 1.6 | 57.5 | 45 | 30 | CJE | 150 | 240 | 6 | 22 | 20 | NXA-1600V165*CJE□B |
| | 1.8 | 57.5 | 45 | 35 | CJH | 150 | 270 | 5 | 23 | 20 | NXA-1600V185*CJH□B |
| | 2 | 57.5 | 50 | 35 | CKH | 150 | 300 | 5 | 24 | 20 | NXA-1600V205*CKH□B |
| | 2.2 | 57.5 | 45 | 45 | CJL | 150 | 330 | 4 | 24 | 20 | NXA-1600V225*CJL□B |
| 2.5 | 57.5 | 55 | 40 | CLJ | 150 | 375 | 4 | 25 | 20 | NXA-1600V255*CLJ□B | |

(Note) * : If tolerance at rated capacitance is 5% = J, 10% = K
 □ : Shape code

For High-frequency Circuits Capacitors

85 °C

High frequency

- Widely used in high voltage, high frequency circuit.
- Low loss and small inherent temperature rise.
- Excellent active and passive flame resistant circuit.
- Double side metallized.
- Especially designed as snubber capacitor for IGBT.

Specifications

| Item | Performance |
|------------------------------------|---|
| Category temperature range (°C) | -40 to +85 (at Hotspot in capacitor) |
| Tolerance at rated capacitance (%) | ±5, ±10 (20°C, 50 to 120Hz) |
| Dielectric Dissipation Factor | 2×10 ⁻⁴ or less |
| Life Expectancy | 100000 hours (at Hotspot in capacitor = 70°C) |
| Failure Rate | 100Fit |
| Withstanding DC Voltage | Between Terminals |
| | Between Terminals and Case |
| Insulation Resistance | 3000MΩ·μF or more (20°C, 100V DC, 1min) |
| Reference Standard | IEC 61071 |

Outline Drawing

Unit : mm

Shape A

Shape B

Shape C

| W | | H | | T | |
|------|------|------|------|------|------|
| Size | Code | Size | Code | Size | Code |
| 42.5 | A | 25.5 | A | 14 | A |
| 43 | B | 28 | B | 24 | B |
| 57.5 | C | 32 | C | 25.5 | C |
| | | 33 | D | 29.5 | D |
| | | 35.5 | E | 30 | E |
| | | 36 | F | 33 | F |
| | | 43 | G | 33.5 | G |
| | | 43.5 | H | 35 | H |
| | | 45 | J | 40 | J |
| | | 50 | K | 42 | K |
| | | 55 | L | 45 | L |

(Note) Tolerance at size : ±1.0

Part numbering system (example : 850V2.2μF)

| | | | | | | | | |
|-------------|---|----------------------|---|--------------------------|------------------------------|---------------|------------|-----------------|
| NXB | — | 850 | V | 225 | K | AJE | C | B |
| Series code | | Rated voltage symbol | | Rated capacitance symbol | Capacitance tolerance symbol | Casing symbol | Shape code | Optional symbol |

NOTE : Design, Specifications are subject to change without notice. It is recommended that you shall obtain technical specifications from ELNA to ensure that the component is suitable for your use.

Standard Ratings

| Rated voltage (V) | Rated capacitance (µF) | Case (mm) | | | Casing symbol | dV / dt (V/µS) | Peak current (A) | ESR (mΩ Max.) | I rms (A) | Self-inductance (nH) | ELNA Parts No. |
|----------------------|---------------------------|-----------|------|------|---------------|-------------------|---------------------|------------------|--------------|-------------------------|--------------------|
| | | W | H | T | | | | | | | |
| 700VDC (380VAC) | 0.6 | 42.5 | 28 | 14 | ABA | 325 | 195 | 12 | 7.2 | 20 | NXB-700V604*ABA□B |
| | 0.8 | 42.5 | 32 | 14 | ACA | 325 | 260 | 12 | 9.2 | 20 | NXB-700V804*ACA□B |
| | 1 | 42.5 | 25.5 | 25.5 | AAC | 325 | 325 | 10 | 10.8 | 20 | NXB-700V105*AA□B |
| | 1.2 | 42.5 | 28 | 24 | ABB | 325 | 390 | 10 | 12.4 | 20 | NXB-700V125*AB□B |
| | 1.8 | 42.5 | 36 | 24 | AFB | 325 | 585 | 8 | 16.8 | 20 | NXB-700V185*AF□B |
| | 2.2 | 42.5 | 33 | 33 | ADF | 325 | 715 | 7 | 18.8 | 20 | NXB-700V225*AD□B |
| | 2.5 | 42.5 | 35.5 | 33.5 | AEG | 325 | 813 | 6 | 20.3 | 20 | NXB-700V255*AE□B |
| | 3 | 42.5 | 45 | 30 | AJE | 325 | 975 | 5 | 22.4 | 20 | NXB-700V305*AJ□B |
| 850VDC (450VAC) | 4 | 42.5 | 43 | 42 | AGK | 325 | 1300 | 4 | 25 | 20 | NXB-700V405*AG□B |
| | 0.47 | 42.5 | 28 | 14 | ABA | 400 | 188 | 12 | 6.4 | 20 | NXB-850V474*ABA□B |
| | 0.55 | 42.5 | 32 | 14 | ACA | 400 | 220 | 12 | 8.8 | 20 | NXB-850V554*ACA□B |
| | 0.68 | 42.5 | 25.5 | 25.5 | AAC | 400 | 272 | 10 | 10.4 | 20 | NXB-850V684*AA□B |
| | 0.8 | 42.5 | 28 | 24 | ABB | 400 | 320 | 10 | 11.8 | 20 | NXB-850V804*AB□B |
| | 1.2 | 42.5 | 36 | 24 | AFB | 400 | 480 | 9 | 15.6 | 20 | NXB-850V125*AF□B |
| | 1.5 | 42.5 | 33 | 33 | ADF | 400 | 600 | 8 | 17.6 | 20 | NXB-850V155*AD□B |
| | 1.8 | 42.5 | 35.5 | 33.5 | AEG | 400 | 720 | 7 | 19.8 | 20 | NXB-850V185*AE□B |
| 1000VDC (480VAC) | 2.2 | 42.5 | 45 | 30 | AJE | 400 | 880 | 6 | 21.5 | 20 | NXB-850V225*AJ□B |
| | 2.8 | 42.5 | 43 | 42 | AGK | 400 | 1120 | 5 | 24 | 20 | NXB-850V285*AG□B |
| | 0.33 | 42.5 | 28 | 14 | ABA | 500 | 165 | 12 | 6.2 | 20 | NXB-1000V334*ABA□B |
| | 0.45 | 42.5 | 32 | 14 | ACA | 500 | 225 | 12 | 8.6 | 20 | NXB-1000V454*ACA□B |
| | 0.55 | 42.5 | 25.5 | 25.5 | AAC | 500 | 275 | 10 | 9.8 | 20 | NXB-1000V554*AA□B |
| | 0.65 | 42.5 | 28 | 24 | ABB | 500 | 325 | 10 | 11.6 | 20 | NXB-1000V654*AB□B |
| | 1 | 42.5 | 36 | 24 | AFB | 500 | 500 | 9 | 15.5 | 20 | NXB-1000V105*AF□B |
| | 1.2 | 42.5 | 33 | 33 | ADF | 500 | 600 | 8 | 17.5 | 20 | NXB-1000V125*AD□B |
| | 1.4 | 42.5 | 35.5 | 33.5 | AEG | 500 | 700 | 7 | 18.8 | 20 | NXB-1000V145*AE□B |
| | 1.8 | 42.5 | 45 | 30 | AJE | 500 | 900 | 6 | 21 | 20 | NXB-1000V185*AJ□B |
| | 2.2 | 42.5 | 43 | 42 | AGK | 500 | 1100 | 5 | 5 | 20 | NXB-1000V225*AG□B |
| | 2.2 | 57.5 | 43.5 | 29.5 | CHD | 350 | 770 | 6 | 6 | 20 | NXB-1000V225*CH□B |
| | 2.5 | 57.5 | 45 | 30 | CJE | 350 | 875 | 5 | 5 | 20 | NXB-1000V255*CJ□B |
| | 3 | 57.5 | 45 | 35 | CJH | 350 | 1050 | 5 | 5 | 20 | NXB-1000V305*CJ□B |
| 1200VDC (500VAC) | 3.3 | 57.5 | 50 | 35 | CKH | 350 | 1155 | 4 | 4 | 20 | NXB-1000V335*CK□B |
| | 3.5 | 57.5 | 45 | 45 | CJL | 350 | 1225 | 4 | 4 | 20 | NXB-1000V355*CJ□B |
| | 4.5 | 57.5 | 55 | 40 | CLJ | 350 | 1575 | 4 | 28 | 20 | NXB-1000V455*CL□B |
| | 0.22 | 42.5 | 28 | 14 | ABA | 650 | 143 | 12 | 6 | 20 | NXB-1200V224*ABA□B |
| | 0.3 | 42.5 | 32 | 14 | ACA | 650 | 195 | 12 | 8.5 | 20 | NXB-1200V304*ACA□B |
| | 0.4 | 42.5 | 25.5 | 25.5 | AAC | 650 | 260 | 11 | 9.6 | 20 | NXB-1200V404*AA□B |
| | 0.47 | 42.5 | 28 | 24 | ABB | 650 | 306 | 10 | 11.5 | 20 | NXB-1200V474*AB□B |
| | 0.68 | 42.5 | 36 | 24 | AFB | 650 | 442 | 10 | 15.4 | 20 | NXB-1200V684*AF□B |
| | 0.8 | 42.5 | 33 | 33 | ADF | 650 | 520 | 9 | 17.2 | 20 | NXB-1200V804*AD□B |
| | 1 | 42.5 | 35.5 | 33.5 | AEG | 650 | 650 | 8 | 18.6 | 20 | NXB-1200V105*AE□B |
| | 1.2 | 42.5 | 45 | 30 | AJE | 650 | 780 | 7 | 20.6 | 20 | NXB-1200V125*AJ□B |
| | 1.5 | 42.5 | 43 | 42 | AGK | 650 | 975 | 6 | 22 | 20 | NXB-1200V155*AG□B |
| 1.5 | 57.5 | 43.5 | 29.5 | CHD | 455 | 683 | 6 | 22 | 20 | NXB-1200V155*CH□B | |
| 1.8 | 57.5 | 45 | 30 | CJE | 455 | 819 | 6 | 23 | 20 | NXB-1200V185*CJ□B | |
| 2 | 57.5 | 45 | 35 | CJH | 455 | 910 | 5 | 24 | 20 | NXB-1200V205*CJ□B | |
| 2.2 | 57.5 | 50 | 35 | CKH | 455 | 1001 | 5 | 24 | 20 | NXB-1200V225*CK□B | |
| 2.5 | 57.5 | 45 | 45 | CJL | 455 | 1138 | 4 | 25 | 20 | NXB-1200V255*CJ□B | |
| 3 | 57.5 | 55 | 40 | CLJ | 455 | 1365 | 4 | 26 | 20 | NXB-1200V305*CL□B | |
| 1600VDC (550VAC) | 0.15 | 42.5 | 28 | 14 | ABA | 800 | 120 | 12 | 6 | 20 | NXB-1600V154*ABA□B |
| | 0.2 | 42.5 | 32 | 14 | ACA | 800 | 160 | 12 | 8.4 | 20 | NXB-1600V204*ACA□B |
| | 0.3 | 42.5 | 25.5 | 25.5 | AAC | 800 | 240 | 11 | 9.5 | 20 | NXB-1600V304*AA□B |
| | 0.33 | 42.5 | 28 | 24 | ABB | 800 | 264 | 11 | 11.4 | 20 | NXB-1600V334*AB□B |
| | 0.47 | 42.5 | 36 | 24 | AFB | 800 | 376 | 10 | 15.2 | 20 | NXB-1600V474*AF□B |
| | 0.56 | 42.5 | 33 | 33 | ADF | 800 | 448 | 10 | 17 | 20 | NXB-1600V564*AD□B |
| | 0.65 | 42.5 | 35.5 | 33.5 | AEG | 800 | 520 | 9 | 18.4 | 20 | NXB-1600V654*AE□B |
| | 0.8 | 42.5 | 45 | 30 | AJE | 800 | 640 | 8 | 20.5 | 20 | NXB-1600V804*AJ□B |
| | 1 | 42.5 | 43 | 42 | AGK | 800 | 800 | 7 | 21 | 20 | NXB-1600V105*AG□B |
| | 1 | 57.5 | 43.5 | 29.5 | CHD | 560 | 560 | 6 | 22 | 20 | NXB-1600V105*CH□B |
| | 1.2 | 57.5 | 45 | 30 | CJE | 560 | 672 | 6 | 22 | 20 | NXB-1600V125*CJ□B |
| | 1.4 | 57.5 | 45 | 35 | CJH | 560 | 784 | 5 | 23 | 20 | NXB-1600V145*CJ□B |
| | 1.6 | 57.5 | 50 | 35 | CKH | 560 | 896 | 5 | 24 | 20 | NXB-1600V165*CK□B |
| | 1.7 | 57.5 | 45 | 45 | CJL | 560 | 952 | 4 | 24 | 20 | NXB-1600V175*CJ□B |
| 2 | 57.5 | 55 | 40 | CLJ | 560 | 1120 | 4 | 25 | 20 | NXB-1600V205*CL□B | |

(Note) * : If tolerance at rated capacitance is 5% = J, 10% = K
 □ : Shape code

MEMO

ELECTRONIC COMPONENTS

ELNA CO., LTD.

<http://www.ena.co.jp/>

| | | |
|------------------|---|--|
| HEAD OFFICE | 3-8-11 Shin-Yokohama, Kouhoku-ku, Yokohama-city, Kanagawa, 222-0033 Japan | TEL. +81-45-470-7251 FAX. +81-45-470-7261 |
| SHIGA FACTORY | 30 Ta-cho, Nagahama-city, Shiga, 529-0142 Japan | TEL. +81-749-73-3021 FAX. +81-749-73-2175 |
| SHIRAKAWA OFFICE | 9-32 Aza-sugiyama, Oaza-yone, Nishigo-mura, Nishishirakawa-gun, Fukushima, 961-8031 Japan | TEL. +81-248-48-1654 FAX. +81-248-25-5614 |

■ SALES OFFICE

| | |
|--|---|
| ELNA AMERICA, INC. 3600 Dallas Hwy., Ste.230 #389 Marietta, GA 30064, U.S.A. | TEL. +1-678-261-8284 FAX. +1-678-815-0892 |
| ELNA ELECTRONICS SINGAPORE PTE. LTD. 103 Kallang Avenue, #04-01 AIS Industrial Building Singapore 339504 | TEL. +65-62930181 FAX. +65-62966716 |
| ELNA (SHANGHAI) CO., LTD. Room 6203, Rui Jin Hotel Business Center 118 Rui Jin 2 Road, Shanghai, China Post Code 200020 | TEL. +86-21-64452269 FAX. +86-21-64452271 |
| ELNA BANGKOK SALES OFFICE 2/71 Thosapol Land Building 4 14th/FL, Soi Bangna-Trad 25, Bangna, Bangna, Bangkok 10260, Thailand | TEL. +66-2-7441464 +66-2-7441465 FAX. +66-2-7441466 |
| ELNA MALAYSIA PENANG SALES OFFICE 2473, Tingkat Perusahaan 6, Free Trade Zone, Prai Industrial Estate, 13600 Prai, Penang, Malaysia | TEL. +60-4-3985369 |
| EASTERN JAPAN OFFICE 3-8-11 Shin-Yokohama, Kouhoku-ku, Yokohama-city Kanagawa, 222-0033 Japan | TEL. +81-45-470-7254 FAX. +81-45-470-7260 |
| WESTERN JAPAN OFFICE 6-1-15 Nishinakajima Yodogawa-ku, Osaka-city, Osaka, 532-0011 Japan | TEL. +81-6-6304-6831 FAX. +81-6-6304-8638 |

■ AFFILIATED COMPANY

| | |
|---|---|
| TANIN ELNA CO., LTD. HEAD OFFICE 2/71 Thosapol Land Building 4 14th/FL, Soi Bangna-Trad 25, Bangna, Bangna, Bangkok 10260, Thailand | TEL. +66-2-7441464 +66-2-7441465 FAX. +66-2-7441466 |
| CHIANGMAI FACTORY 56 Mahidoal Road T. Sutep A. Muang Chiangmai 50200, Thailand. | TEL. +66-53-270206 FAX. +66-53-275064 |
| ELNA-SONIC SDN. BHD. 2473, Tingkat Perusahaan 6, Free Trade Zone, Prai Industrial Estate, 13600 Prai, Penang, Malaysia. | TEL. +60-4-3992916 FAX. +60-4-3992925 Sales office TEL. +60-4-3985369 |
| ELNA TOHOKU CO., LTD. AOMORI FACTORY 1-349-1 Okonoki, Kuroishi-city Aomori, 036-0357 Japan | TEL. +81-172-52-4166 FAX. +81-172-53-4609 |



CAUTION

Observe the following to ensure safe operation.

1. The models and specification values contained in this catalog are for reference purposes only. During actual use or when placing an order, please request "drawings" and make your purchase or use the purchased product based on those drawings.
2. In order to ensure that products are used correctly and safely, always make sure to read the cautions for using prior to using the product.

NOTE

1. Since the contents contained are subject to changes in specifications, dimensions and so forth without notice due to modification, please confirm the contents when placing an order. If any of the matters described here are unclear, please inquire at one of our nearby sales offices.
2. The contents of this catalog are valid as of December 2014.



Стандарт Электрон Связь

Мы молодая и активно развивающаяся компания в области поставок электронных компонентов. Мы поставляем электронные компоненты отечественного и импортного производства напрямую от производителей и с крупнейших складов мира.

Благодаря сотрудничеству с мировыми поставщиками мы осуществляем комплексные и плановые поставки широчайшего спектра электронных компонентов.

Собственная эффективная логистика и склад в обеспечивает надежную поставку продукции в точно указанные сроки по всей России.

Мы осуществляем техническую поддержку нашим клиентам и предпродажную проверку качества продукции. На все поставляемые продукты мы предоставляем гарантию .

Осуществляем поставки продукции под контролем ВП МО РФ на предприятия военно-промышленного комплекса России , а также работаем в рамках 275 ФЗ с открытием отдельных счетов в уполномоченном банке. Система менеджмента качества компании соответствует требованиям ГОСТ ISO 9001.

Минимальные сроки поставки, гибкие цены, неограниченный ассортимент и индивидуальный подход к клиентам являются основой для выстраивания долгосрочного и эффективного сотрудничества с предприятиями радиоэлектронной промышленности, предприятиями ВПК и научно-исследовательскими институтами России.

С нами вы становитесь еще успешнее!

Наши контакты:

Телефон: +7 812 627 14 35

Электронная почта: sales@st-electron.ru

Адрес: 198099, Санкт-Петербург,
Промышленная ул, дом № 19, литера Н,
помещение 100-Н Офис 331