



# 3.3 VOLT TIME SLOT INTERCHANGE DIGITAL SWITCH 256 x 256

IDT72V70190

## FEATURES:

- 256 x 256 channel non-blocking switching at 2.048 Mb/s
- Per-channel variable or constant throughput delay
- Automatic identification of ST-BUS®/GCI interfaces
- Accept 8 serial data streams of 2.048 Mb/s
- Automatic frame offset delay measurement
- Per-stream frame delay offset programming
- Per-channel high impedance output control
- Per-channel Processor Mode
- Control interface compatible to Intel/Motorola CPUs
- Connection memory block programming
- Available in 64-pin Thin Plastic Quad Flatpack (TQFP)

- 3.3V Power Supply
- Operating Temperature Range -40°C to +85°C
- 3.3V I/O with 5V Tolerant Inputs

## DESCRIPTION:

The IDT72V70190 is a non-blocking digital switch that has a capacity of 256 x 256 channels at 2.048 Mb/s. Some of the main features are: programmable stream and channel control, Processor Mode, input offset delay and high-impedance output control.

Per-stream input delay control is provided for managing large multi-chip switches that transport both voice channel and concatenated data channels. In addition, input streams can be individually calibrated for input frame offset.

## FUNCTIONAL BLOCK DIAGRAM

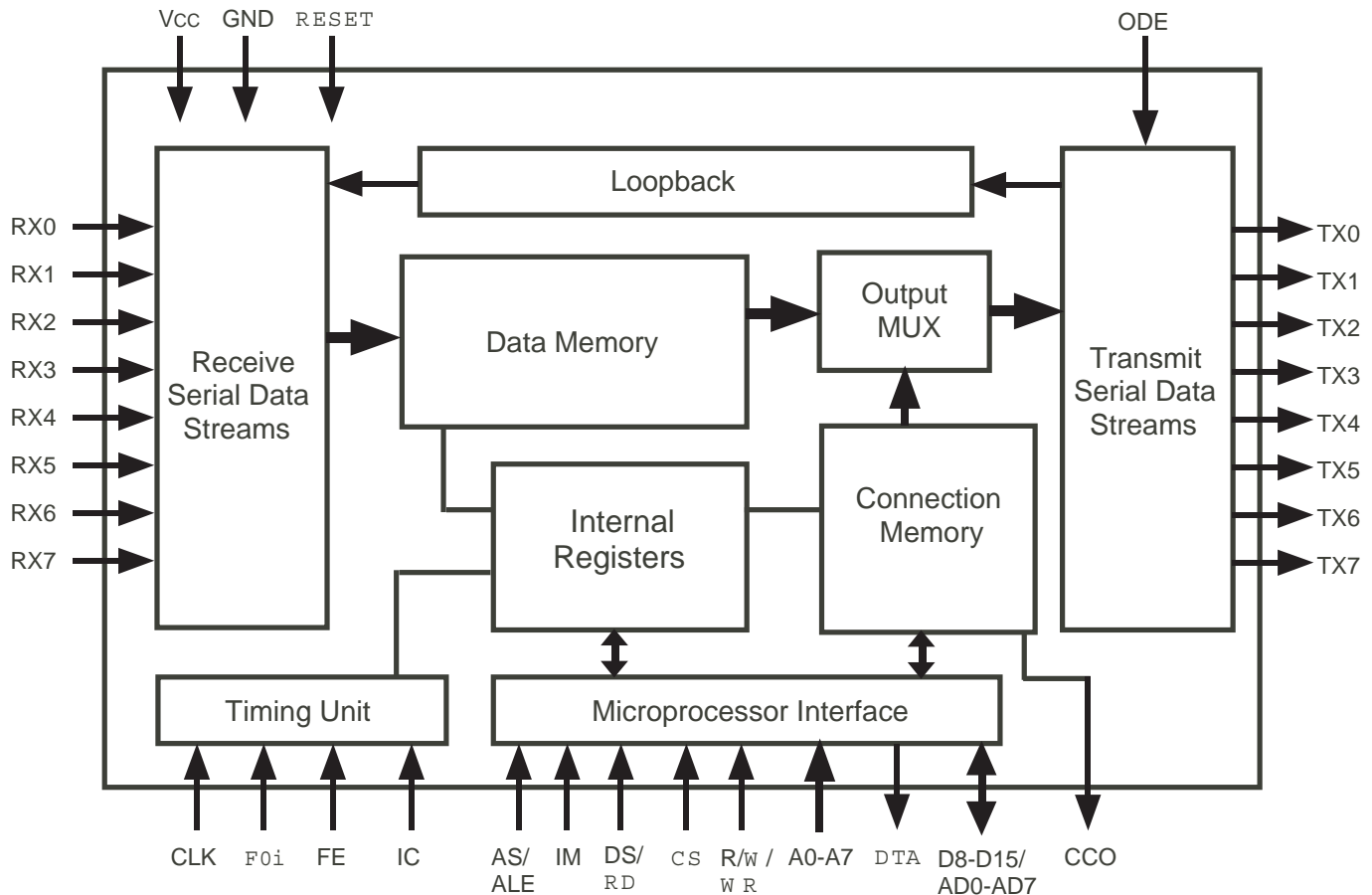

PIN CONFIGURATIONS

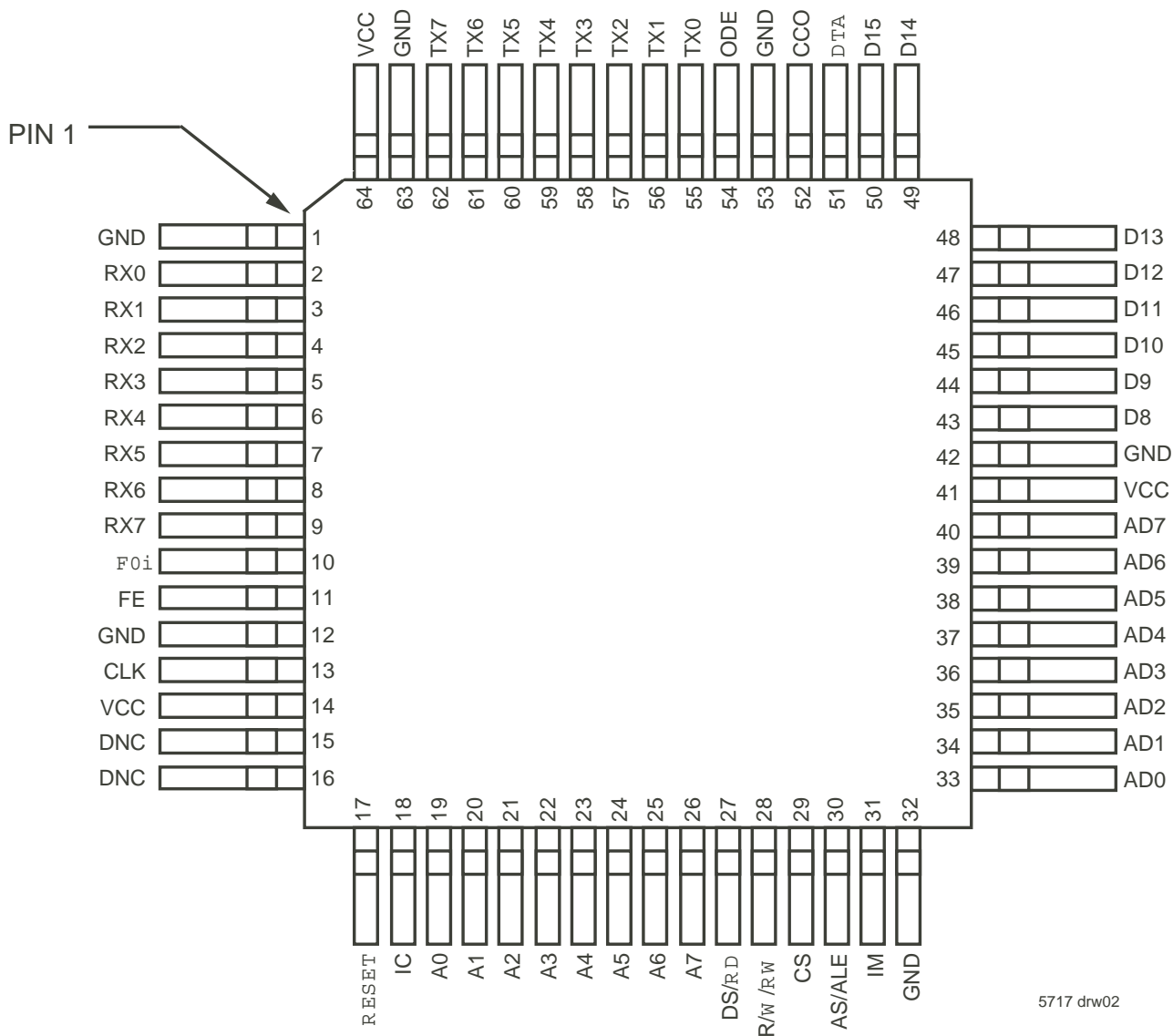

5717 drw02

TQFP 0.80 pitch, 14mm x 14mm (PN64-1, order code: PF)  
STQFP 0.50 pitch, 10mm x 10mm (PP64-1, order code: TF)  
TOP VIEW

NOTES:

1. DNC - Do Not Connect.
2. All I/O pins are 5V tolerant.
3. IC - Internal Connection, tie to Ground for normal operation.

## PIN DESCRIPTION

SYMBOL	NAME	I/O	DESCRIPTION
GND	Ground.		Ground Rail.
Vcc	Vcc		+3.3 Volt Power Supply.
TX0-7	TX Output 0 to 7 (Three-state Outputs)	O	Serial data output stream. These streams have a data rate of 2.048 Mb/s.
RX0-7	RX Input 0 to 7	I	Serial data input stream. These streams have a data rate of 2.048 Mb/s.
$\overline{F0i}$	Frame Pulse	I	This input accepts and automatically identifies frame synchronization signals formatted according to ST-BUS® and GCI specifications.
FE	Frame Evaluation	I	This pin is the frame measurement input.
CLK	Clock	I	Serial clock for shifting data in/out on the serial streams (RX/TX 0-7). This input accepts a 4.096 MHz clock.
$\overline{RESET}$	Device Reset (Schmitt Trigger Input)	I	This input (active LOW) puts the IDT72V70190 in its reset state that clears the device internal counters, registers and brings TX0-7 and microport data outputs to a high-impedance state. The time constant for a power up reset circuit must be a minimum of five times the rise time of the power supply. In normal operation, the $\overline{RESET}$ pin must be held LOW for a minimum of 100ns to reset the device.
A0-7	Address 0-7	I	When non-multiplexed CPU bus operation is selected, these lines provide the A0-A7 address lines to the internal memories.
$DS/\overline{RD}$	Data Strobe/Read	I	For Motorola multiplexed bus operation, this input is DS. This active HIGH DS input works in conjunction with $\overline{CS}$ to enable the read and write operations. For Motorola non-multiplexed CPU bus operation, this input is DS. This active LOW input works in conjunction with $\overline{CS}$ to enable the read and write operations. For Intel multiplexed bus operation, this input is $\overline{RD}$ . This active LOW input sets the data bus lines (AD0-7, D8-15) as outputs.
$R/\overline{W}$ / $\overline{WR}$	Read/Write / Write	I	In the cases of Motorola non-multiplexed and multiplexed bus operations, this input is $R/\overline{W}$ . This input controls the direction of the data bus lines (AD0-7, D8-15) during a microprocessor access. For Intel multiplexed bus operation, this input is $\overline{WR}$ . This active LOW input is used with $\overline{RD}$ to control the data bus (AD0-7) lines as inputs.
$\overline{CS}$	Chip Select	I	Active LOW input used by a microprocessor to activate the microprocessor port of IDT72V70190.
AS/ALE	Address Strobe or Latch Enable	I	This input is used if multiplexed bus operation is selected via the IM input pin. For Motorola non-multiplexed bus operation, connect this pin to ground.
IM	CPU Interface Mode	I	When IM is HIGH, the microprocessor port is in the multiplexed mode. When IM is LOW, the microprocessor port is in non-multiplexed mode.
AD0-7	Address/Data Bus 0 to 7	I/O	These pins are the eight least significant data bits of the microprocessor port. In multiplexed mode, these pins are also the input address bits of the microprocessor port.
D8-15	Data Bus 8-15	I/O	These pins are the eight most significant data bits of the microprocessor port.
$\overline{DTA}$	Data Transfer Acknowledgment	O	This active LOW output signal indicates that a data bus transfer is complete. When the bus cycle ends, this pin drives HIGH and then goes high-impedance, allowing for faster bus cycles with a weaker pull-up resistor. A pull-up resistor is required to hold a HIGH level when the pin is in high-impedance.
CCO	Control Output	O	This is a 4.096 Mb/s output containing 512 bits per frame respectively. The level of each bit is determined by the CCO bit in the connection memory. See External Drive Control Section.
ODE	Output Drive Enable	I	This is the output enable control for the TX0 to TX7 serial outputs. When ODE input is LOW and the OSB bit of the IMS register is LOW, TX0-7 are in a high-impedance state. If this input is HIGH, the TX0-7 output drivers are enabled. However, each channel may still be put into a high-impedance state by using the per channel control bit in the connection memory.

## FUNCTIONAL DESCRIPTION

The IDT72V70190 is capable of switching 256 x 256, 64 Kbit/s PCM or N x 64 Kbit/s channel data. The device maintains frame integrity in data applications and minimum throughput delay for voice applications on a per channel basis.

The serial input streams of the IDT72V70190 can have a bit rate of 2.048 Mb/s and are arranged in 125 $\mu$ s wide frames, which contain 32 channels respectively. The data rates on input and output streams are identical.

In Processor Mode, the microprocessor can access input and output time-slots on a per channel basis allowing for transfer of control and status information. The IDT72V70190 automatically identifies the polarity of the frame synchronization input signal and configures the serial streams to either ST-BUS<sup>®</sup> or GCI formats.

With the variety of different microprocessor interfaces, IDT72V70190 has provided an Input Mode pin (IM) to help integrate the device into different microprocessor based environments: Non-multiplexed or Multiplexed. These interfaces provide compatibility with multiplexed and Motorola non-multiplexed buses. The device can also resolve different control signals eliminating the use of glue logic necessary to convert the signals ( $R/\overline{W}/\overline{WR}$ ,  $DS/\overline{RD}$ ,  $AS/\overline{ALE}$ ).

The frame offset calibration function allows users to measure the frame offset delay using a frame evaluation pin (FE). The input offset delay can be programmed for individual streams using internal frame input offset registers, see Table 8.

The internal loopback allows the TX output data to be looped around to the RX inputs for diagnostic purposes.

A functional Block Diagram of the IDT72V70190 is shown in Figure 1.

## DATA AND CONNECTION MEMORY

The received serial data is converted to parallel format by internal serial-to-parallel converters and stored sequentially in the data memory. The 8KHz input frame pulse ( $\overline{FOi}$ ) is used to generate channel and frame boundaries of the input serial data. Depending on the interface mode select (IMS) register, the usable data memory may be as large as 256 bytes.

Data to be output on the serial streams (TX0-7) may come from either the data memory or connection memory. For data output from data memory (connection mode), addresses in the connection memory are used. For data to be output from connection memory, the connection memory control bits must set the particular TX output in Processor Mode. One time-slot before the data is to be output, data from either connection memory or data memory is read internally. This allows enough time for memory access and parallel-to-serial conversion.

Clock is required for data and connection memory access.

## CONNECTION AND PROCESSOR MODES

In the Connection Mode, the addresses of the input source data for all output channels are stored in the connection memory. The connection memory is mapped in such a way that each location corresponds to an output channel on the output streams. For details on the use of the source address data (CAB and SAB bits), see Table 10. Once the source address bits are programmed by the microprocessor, the contents of the data memory at the selected address are transferred to the parallel-to-serial converters and then onto a TX output stream.

By having the each location in the connection memory specify an input channel, multiple outputs can specify the same input address. This can be a powerful tool used for broadcasting data.

In Processor Mode, the microprocessor writes data to the connection memory. Each location in the connection memory corresponds to a particular output stream and channel number and is transferred directly to the parallel-to-

serial converter one time-slot before it is to be output. This data will be output on the TX streams in every frame until the data is changed by the microprocessor.

As the IDT72V70190 can be used in a wide variety of applications, the device also has memory locations to control the outputs based on operating mode. Specifically, the IDT72V70190 provides five per-channel control bits for the following functions: processor or connection mode, constant or variable delay, enables/three-state the TX output drivers and enables/disable the loopback function. In addition, one of these bits allows the user to control the CCO output.

If an output channel is set to a high-impedance state through the connection memory, the TX output will be in a high-impedance state for the duration of that channel. In addition to the per-channel control, all channels on the ST-BUS<sup>®</sup> outputs can be placed in a high impedance state by either pulling the ODE input pin low or programming the Output Stand-By (OSB) bit in the interface mode selection register. This action overrides the per-channel programming in the connection memory bits.

The connection memory data can be accessed via the microprocessor interface. The addressing of the devices internal registers, data and connection memories is performed through the address input pins and the Memory Select (MS) bit of the control register. For details on device addressing, see Software Control and Control Register bits description (Table 3 and 5).

## SERIAL DATA INTERFACE TIMING

The master clock frequency must always be twice the data rate. For serial data rates of 2.048 Mb/s, the master clock (CLK) must be at 4.096 MHz. The input and output stream data rates will always be identical.

The input 8 KHz frame pulse can be in either ST-BUS<sup>®</sup> or GCI format. The IDT72V70190 automatically detects the presence of an input frame pulse and identifies it as either ST-BUS<sup>®</sup> or GCI. In ST-BUS<sup>®</sup> format, every second falling edge of the master clock marks a bit boundary and the data is clocked in on the rising edge of CLK, three quarters of the way into the bit cell, see Figure 7. In GCI format, every second rising edge of the master clock marks the bit boundary and data is clocked in on the falling edge of CLK at three quarters of the way into the bit cell, see Figure 8.

## INPUT FRAME OFFSET SELECTION

Input frame offset selection allows the channel alignment of individual input streams to be offset with respect to the output stream channel alignment (i.e.  $\overline{FOi}$ ). Although all input data comes in at the same speed, delays can be caused by variable path serial backplanes and variable path lengths which may be implemented in large centralized and distributed switching systems. Because data is often delayed, this feature is useful in compensating for the skew between clocks.

Each input stream can have its own delay offset value by programming the frame input offset registers (FOR). The maximum allowable skew is +4.5 master clock (CLK) periods forward with resolution of  $\frac{1}{2}$  clock period. The output frame offset cannot be offset or adjusted. See Figure 5, Table 8 and 9 for delay offset programming.

## SERIAL INPUT FRAME ALIGNMENT EVALUATION

The IDT72V70190 provides the frame evaluation (FE) input to determine different data input delays with respect to the frame pulse  $\overline{FOi}$ .

A measurement cycle is started by setting the start frame evaluation (SFE) bit low for at least one frame. When the SFE bit in the IMS register is changed from low to high, the evaluation starts. Two frames later, the complete frame evaluation (CFE) bit of the frame alignment register (FAR) changes from low to high to signal that a valid offset measurement is ready to be read from bits 0

to 11 of the FAR register. The SFE bit must be set to zero before a new measurement cycle started.

In ST-BUS® mode, the falling edge of the frame measurement signal (FE) is evaluated against the falling edge of the ST-BUS® frame pulse. In GCI mode, the rising edge of FE is evaluated against the rising edge of the GCI frame pulse. See Table 7 and Figure 4 for the description of the frame alignment register.

### MEMORY BLOCK PROGRAMMING

The IDT72V70190 provides users with the capability of initializing the entire connection memory block in two frames. To set bits 11 to 15 of every connection memory location, first program the desired pattern in bits 5 to 9 of the IMS register.

The block programming mode is enabled by setting the memory block program (MBP) bit of the control register high. When the block programming enable (BPE) bit of the IMS register is set to high, the block programming data will be loaded into the bits 11 to 15 of every connection memory location. The other connection memory bits (bit 0 to bit 10) are loaded with zeros. When the memory block programming is complete, the device resets the BPE bit to zero.

### LOOPBACK CONTROL

The loopback control (LPBK) bit of each connection memory location allows the TX output data to be looped back internally to the RX input for diagnostic purposes.

If the LPBK bit is high, the associated TX output channel data is internally looped back to the RX input channel (i.e., data from TX n channel m routes to the RX n channel m internally); if the LPBK bit is low, the loopback feature is disabled. For proper per-channel loopback operation, the contents of frame delay offset registers must be set to zero.

## DELAY THROUGH THE IDT72V70190

The switching of information from the input serial streams to the output serial streams results in a throughput delay. The device can be programmed to perform time-slot interchange functions with different throughput delay capabilities on the per-channel basis. For voice applications, variable throughput delay is best as it ensures minimum delay between input and output data. In wideband data applications, constant throughput delay is best as the frame integrity of the information is maintained through the switch.

The delay through the device varies according to the type of throughput delay selected in the  $\bar{V}/C$  bit of the connection memory.

### VARIABLE DELAY MODE ( $\bar{V}/C$ BIT = 0)

In this mode, the delay is dependent only on the combination of source and destination channels and is independent of input and output streams. The minimum delay achievable in the IDT72V70190 is three time-slots. If the input channel data is switched to the same output channel (channel n, frame p), it will be output in the following frame (channel n, frame p+1). The same is true if input channel n is switched to output channel n+1 or n+2. If the input channel n is switched to output channel n+3, n+4, ..., the new output data will appear in the same frame. Table 1 shows the possible delays for the IDT72V70190 in the variable delay mode.

### CONSTANT DELAY MODE ( $\bar{V}/C$ BIT = 1)

In this mode, frame integrity is maintained in all switching configurations by making use of a multiple data memory buffer. Input channel data is written into the data memory buffers during frame n will be read out during frame n+2. In the IDT72V70190, the minimum throughput delay achievable in the constant delay mode will be one frame. For example, when input time-slot 31 is switched

to output time-slot 0. The maximum delay of 94 time-slots of delay occurs when time-slot 0 in a frame is switched to time-slot 31 in the frame. See Table 2.

## MICROPROCESSOR INTERFACE

The IDT72V70190 provides a parallel microprocessor interface for multiplexed or non-multiplexed bus structures. This interface is compatible with Motorola non-multiplexed and multiplexed buses.

If the IM pin is low a Motorola non-multiplexed bus should be connected to the device. If the IM pin is high, the device monitors the AS/ALE and DS/ $\bar{R}\bar{D}$  to determine what mode the IDT72V70190 should operate in.

If DS/ $\bar{R}\bar{D}$  is low at the rising edge of AS/ALE, then the mode 1 multiplexed timing is selected. If DS/ $\bar{R}\bar{D}$  is high at the rising edge of AS/ALE, then the mode 2 multiplexed bus timing is selected.

For multiplexed operation, the required signals are the 8-bit data and address (AD0-AD7), 8-bit Data (D8-D15), Address strobe/Address latch enable (AS/ALE), Data strobe/Read (DS/ $\bar{R}\bar{D}$ ), Read/Write/Write (R/ $\bar{W}$ / $\bar{W}\bar{R}$ ), Chip select ( $\bar{C}\bar{S}$ ) and Data transfer acknowledge ( $\bar{D}\bar{T}\bar{A}$ ). See Figure 11 and Figure 12 for multiplexed parallel microport timing.

For the Motorola non-multiplexed bus, the required signals are the 16-bit data bus (AD0-AD7, D8-D15), 8-bit address bus (A0-A7) and 4 control lines ( $\bar{C}\bar{S}$ , DS, R/ $\bar{W}$  and  $\bar{D}\bar{T}\bar{A}$ ). See Figure 13 and 14 for Motorola non-multiplexed microport timing.

The IDT72V70190 microport provides access to the internal registers, connection and data memories. All locations provide read/write access except for the data memory and the frame alignment register which are read only.

### MEMORY MAPPING

The address bus on the microprocessor interface selects the internal registers and memories of the IDT72V70190.

If the A7 address input is low, then A6 through A0 are used to address the interface mode selection (IMS), control (CR), frame alignment (FAR) and frame input offset (FOR) registers (Table 4). If the A7 is high, A6 and A5 are low, then A4 through A0 are used to select 32 locations corresponding to data rate of the ST-BUS®. The address input lines and the stream address bits (STA) of the control register allow access to the entire data and connection memories. The control and IMS registers together control all the major functions of the device, see Figure 3.

As explained in the Serial Data Interface Timing and Switching Configurations sections, after system power-up, the IMS register should be programmed immediately to establish the desired switching configuration.

The data in the control register consists of the memory block programming bit (MBP), the memory select bit (MS) and the stream address bits (STA). As explained in the Memory Block Programming section, the MBP bit allows the entire connection memory block to be programmed. The memory select bit is used to designate the connection memory or the data Memory. The stream address bits select internal memory subsections corresponding to input or output serial streams.

The data in the IMS register consists of block programming bits (BPD0-BPD4), block programming enable bit (BPE), output stand by bit (OSB) and start frame evaluation bit (SFE). The block programming and the block programming enable bits allows users to program the entire connection memory (see Memory Block Programming section). If the ODE pin is low, the OSB bit enables (if high) or disables (if low) all ST-BUS® output drivers. If the ODE pin is high, the contents of the OSB bit is ignored and all TX output drivers are enabled.

**CONNECTION MEMORY CONTROL**

The CCO pin is a 4.096 Mb/s output, which carries 512 bits. The contents of the CCO bit of each connection memory location are output on the CCO pin once every frame. The contents of the CCO bits of the connection memory are transmitted sequentially on to the CCO pin (2 bit cells for each bit in connection memory) and are synchronous with the data rates on the other serial streams. The CCO bit is output one channel before the corresponding channel on the serial streams.

If the ODE pin or the OSB bit is high, the OE bit of each connection memory location controls the output drivers-enables (if high) or disables (if low). See Table 4 for detail.

The processor channel (PC) bit of the connection memory selects between Processor Mode and Connection Mode. If high, the contents of the connection memory are output on the TX streams. If low, the stream address bit (SAB) and the channel address bit (CAB) of the connection memory defines the source information (stream and channel) of the time-slot that will be switched to the output from data memory.

The  $\bar{V}/C$  (Variable/Constant Delay) bit in each connection memory location allows the per-channel selection between variable and constant throughput delay modes.

If the LPBK bit is high, the associated TX output channel data is internally looped back to the RX input channel (i.e., RX n channel m data comes from the TX n channel m). If the LPBK bit is low, the loopback feature is disabled. For proper per-channel loopback operation, the contents of the frame delay offset registers must be set to zero.

**INITIALIZATION OF THE IDT72V70190**

After power up, the state of the connection memory is unknown. As such, the outputs should be put in high impedance by holding the ODE low. While the ODE is low, the microprocessor can initialize the device, program the active paths, and disable unused outputs by programming the OE bit in connection memory. Once the device is configured, the ODE pin (or OSB bit depending on initialization) can be switched.

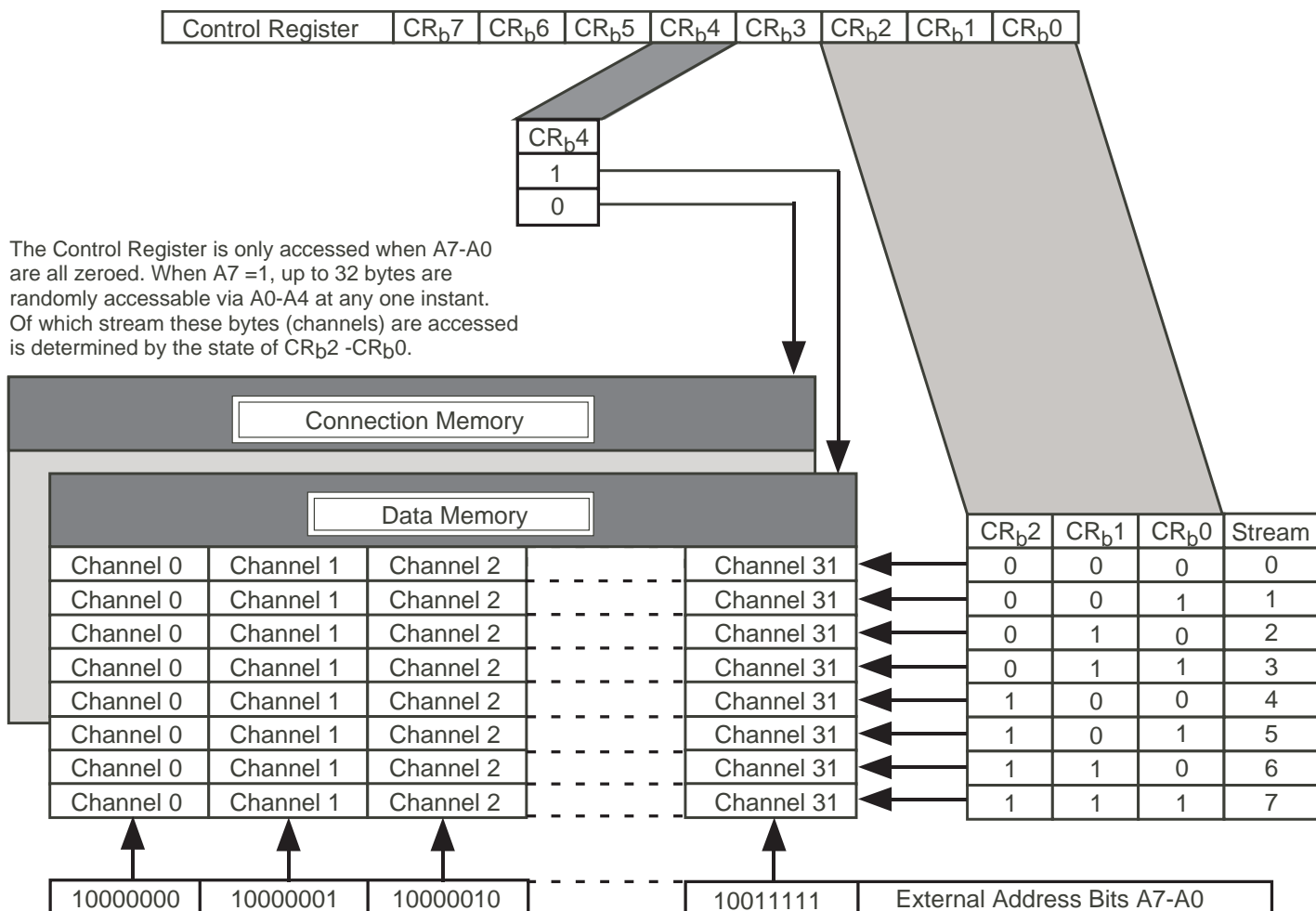

5717 drw03

Figure 3. Addressing Internal Memories

TABLE 1 — VARIABLE THROUGHPUT DELAY VALUE

Input Rate	Delay for Variable Throughput Delay Mode (m – output channel number) (n – input channel number)		
	m < n	m = n, n+1, n+2	m > n+2
2.048 Mb/s	32 – (n-m) time-slots	m-n+32 time-slots	m-n time-slots

TABLE 2 — CONSTANT THROUGHPUT DELAY VALUE

Input Rate	Delay for Constant Throughput Delay Mode (m – output channel number) (n – input channel number)
2.048 Mb/s	32 + (32 – n) + m time-slots

TABLE 3 — INTERNAL REGISTER AND ADDRESS MEMORY MAPPING

A7 <sup>(1)</sup>	A6	A5	A4	A3	A2	A1	A0	Location
0	0	0	0	0	0	0	0	Control Register, CR
0	0	0	0	0	0	0	1	Interface Mode Selection Register, IMS
0	0	0	0	0	0	1	0	Frame Alignment Register, FAR
0	0	0	0	0	0	1	1	Frame Input Offset Register 0, FOR0
0	0	0	0	0	1	0	0	Frame Input Offset Register 1, FOR1
1	0	0	0	0	0	0	0	Ch0
1	0	0	0	0	0	0	1	Ch1
1	0	0	.	.	.	.	.	.
1	0	0	1	1	1	1	0	Ch30
1	0	0	1	1	1	1	1	Ch31

NOTE:

1. Bit A7 must be high for access to data and connection memory positions. Bit A7 must be low for access to registers.

TABLE 4 — OUTPUT HIGH IMPEDANCE CONTROL

OE bit in Connection Memory	ODE pin	OSB bit in IMS Register	TX Output Driver Status
0	Don't Care	Don't Care	Per Channel High-Impedance
1	0	0	High-Impedance
1	0	1	Enable
1	1	1	Enable
1	1	0	Enable

TABLE 5 — CONTROL REGISTER (CR) BITS

Read/Write Address: 00H.															
Reset Value: 0000H.															
15	14	13	12	11	10	9	8	7	6	5	4	3	2	1	0
0	0	0	0	0	0	0	0	0	0	MBP	MS	0	STA2	STA1	STA0

Bit	Name	Description
15-6	Unused	Must be zero for normal operation.
5	MBP (Memory Block Program)	When 1, the connection memory block programming feature is ready for the programming of Connection Memory high bits, bit 11 to bit 15. When 0, this feature is disabled.
4	MS (Memory Select)	When 0, connection memory is selected for read or write operations. When 1, the data memory is selected for read operations and connection memory is selected for write operations. (No microprocessor write operation is allowed for the data memory).
3	Unused	Must be zero for normal operation.
2-0	STA2-0 (Stream Address Bits)	The binary value expressed by these bits refers to the input or output data stream, which corresponds to the subsection of memory made accessible for subsequent operations. (STA2 = MSB, STA0 = LSB)

TABLE 6 — INTERFACE MODE SELECTION (IMS) REGISTER BITS

Read/Write Address: 01H.															
Reset Value: 0000H.															
15	14	13	12	11	10	9	8	7	6	5	4	3	2	1	0
0	0	0	0	0	0	BPD4	BPD3	BPD2	BPD1	BPD0	BPE	OSB	SFE	0	0

Bit	Name	Description
15-10	Unused	Must be zero for normal operation.
9-5	BPD4-0 (Block Programming Data)	These bits carry the value to be loaded into the connection memory block whenever the memory block programming feature is activated. After the MBP bit in the control register is set to 1 and the BPE bit is set to 1, the contents of the bits BPD4-0 are loaded into bit 15 and 11 of the connection memory. Bit 10 to bit 0 of the connection memory are set to 0.
4	BPE (Begin Block Programming Enable)	A zero to one transition of this bit enables the memory block programming function. The BPE and BPD4-0 bits in the IMS register have to be defined in the same write operation. Once the BPE bit is set HIGH, the device requires two frames to complete the block programming. After the programming function has finished, the BPE bit returns to zero to indicate the operation is completed. When the BPE = 1, the BPE or MBP can be set to 0 to abort to ensure proper operation. When BPE = 1, the other bit in the IMS register must not be changed for two frames to ensure proper operation.
3	OSB (Output Stand By)	When ODE = 0 and OSB = 0, the output drivers of TX0 to TX7 are in high impedance mode. When ODE = 0 and OSB = 1, the output driver of TX0 to TX7 function normally. When ODE = 1, TX0 to TX7 output drivers function normally.
2	SFE (Start Frame Evaluation)	A zero to one transition in this bit starts the frame evaluation procedure. When the CFE bit in the FAR register changes from zero to one, the evaluation procedure stops. To start another frame evaluation cycle, set this bit to zero for at least one frame.
1-0	Unused	Must be zero for normal operation.

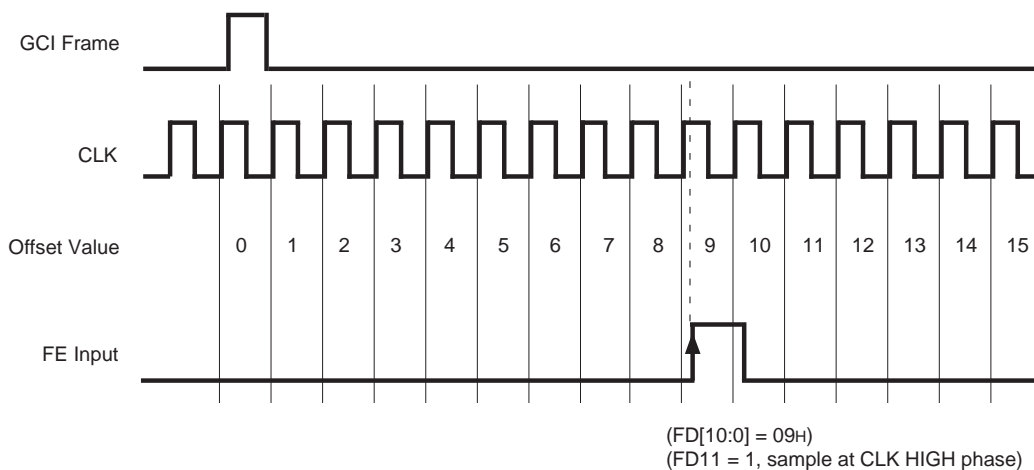
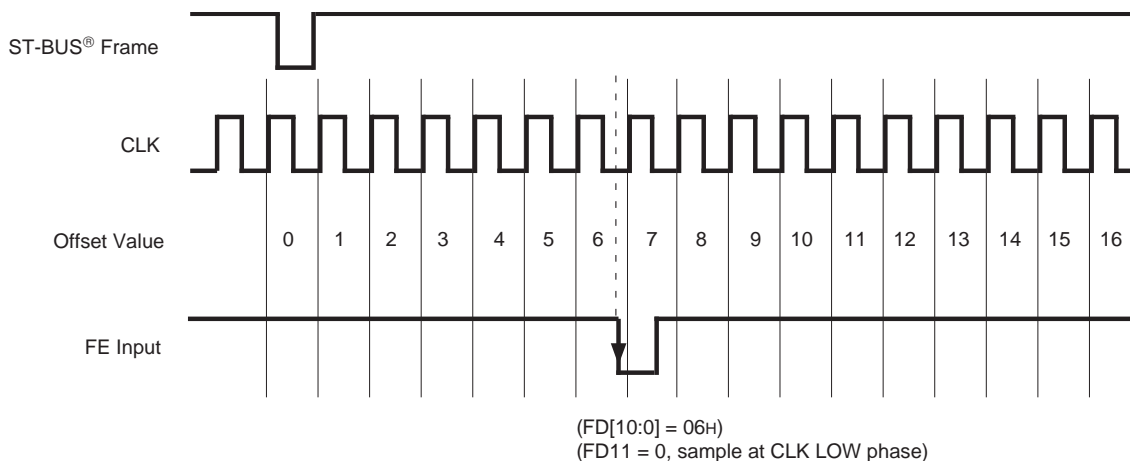

TABLE 7 — FRAME ALIGNMENT REGISTER (FAR) BITS

Read/Write Address: 02H.															
Reset Value: 0000H.															
15	14	13	12	11	10	9	8	7	6	5	4	3	2	1	0
0	0	0	CFE	FD11	FD10	FD9	FD8	FD7	FD6	FD5	FD4	FD3	FD2	FD1	FD0

Bit	Name	Description
15-13	Unused	Must be zero for normal operation.
12	CFE (Complete Frame Evaluation)	When CFE = 1, the frame evaluation is completed and bits FD10 to FD0 bits contains a valid frame alignment offset. This bit is reset to zero, when SFE bit in the IMS register is changed from 1 to 0.
11	FD11 (Frame Delay Bit 11)	The falling edge of FE (or rising edge for GCI mode) is sampled during the CLK-high phase (FD11 = 1) or during the CLK-low phase (FD11 = 0). This bit allows the measurement resolution to ½ CLK cycle.
10-0	FD10-0 (Frame Delay Bits)	The binary value expressed in these bits refers to the measured input offset value. These bits are reset to zero when the SFE bit of the IMS register changes from 1 to 0. (FD10 – MSB, FD0 – LSB)



5717 drw04

Figure 4. Example for Frame Alignment Measurement

TABLE 8 — FRAME INPUT OFFSET REGISTER (FOR) BITS

Read/Write Address:	03H for FOR0 register, 04H for FOR1 register.														
Reset Value:	0000H for all FOR registers.														
15	14	13	12	11	10	9	8	7	6	5	4	3	2	1	0
OF32	OF31	OF30	DLE3	OF22	OF21	OF20	DLE2	OF12	OF11	OF10	DLE1	OF02	OF01	OF00	DLE0
<b>FOR0 Register</b>															
15	14	13	12	11	10	9	8	7	6	5	4	3	2	1	0
OF72	OF71	OF70	DLE7	OF62	OF61	OF60	DLE6	OF52	OF51	OF50	DLE5	OF42	OF41	OF40	DLE4
<b>FOR1 Register</b>															
Name <sup>(1)</sup>	Description														
OFn2, OFn1, OFn0 (Offset Bits 2, 1 & 0)	These three bits define how long the serial interface receiver takes to recognize and store bit 0 from the RX input pin: i.e., to start a new frame. The input frame offset can be selected to +4.5 clock periods from the point where the external frame pulse input signal is applied to the $\overline{FOi}$ input of the device. See Figure 5.														
DLEn (Data Latch Edge)	ST-BUS <sup>®</sup> mode:     DLEn = 0, if clock rising edge is at the $\frac{3}{4}$ point of the bit cell. DLEn = 1, if when clock falling edge is at the $\frac{3}{4}$ of the bit cell. GCI mode:           DLEn = 0, if clock falling edge is at the $\frac{3}{4}$ point of the bit cell. DLEn = 1, if when clock rising edge is at the $\frac{3}{4}$ of the bit cell.														

NOTE:

1. n denotes an input stream number from 0 to 7.

TABLE 9 — OFFSET BITS (OFn2, OFn1, OFn0, DLEn) & FRAME DELAY BITS (FD11, FD2-0)

Input Stream Offset	Measurement Result from Frame Delay Bits				Corresponding Offset Bits			
	FD11	FD2	FD1	FD0	OFn2	OFn1	OFn0	DLEn
No clock period shift (Default)	1	0	0	0	0	0	0	0
+0.5 clock period shift	0	0	0	0	0	0	0	1
+1.0 clock period shift	1	0	0	1	0	0	1	0
+1.5 clock period shift	0	0	0	1	0	0	1	1
+2.0 clock period shift	1	0	1	0	0	1	0	0
+2.5 clock period shift	0	0	1	0	0	1	0	1
+3.0 clock period shift	1	0	1	1	0	1	1	0
+3.5 clock period shift	0	0	1	1	0	1	1	1
+4.0 clock period shift	1	1	0	0	1	0	0	0
+4.5 clock period shift	0	1	0	0	1	0	0	1

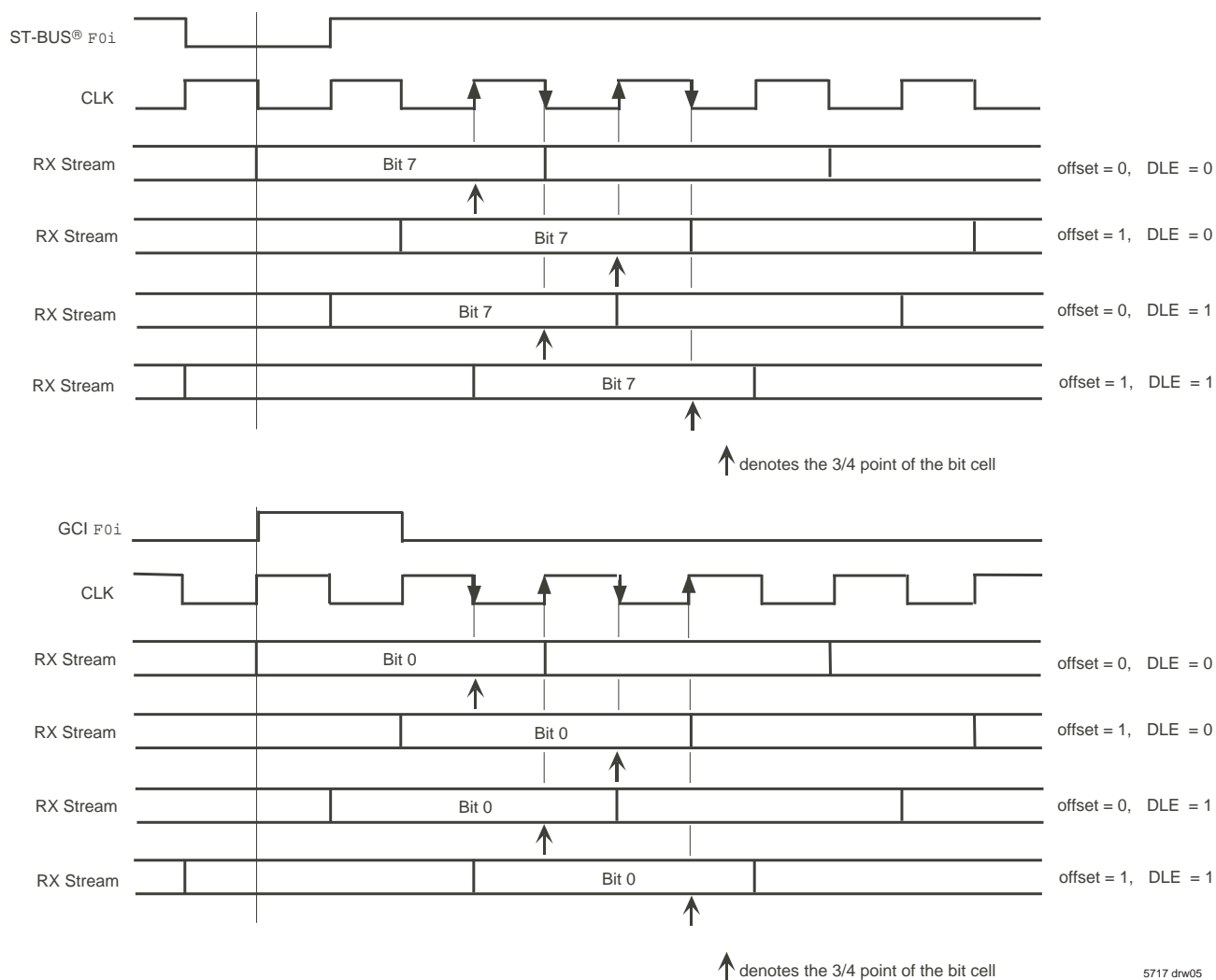

Figure 5. Examples for Input Offset Delay Timing

TABLE 10— CONNECTION MEMORY BITS

	15	14	13	12	11	10	9	8	7	6	5	4	3	2	1	0
	LPBK	$\bar{V}/C$	PC	CCO	OE	0	SAB2	SAB1	SAB0	0	0	CAB4	CAB3	CAB2	CAB1	CAB0

Bit	Name	Description
15	LPBK (Per Channel Loopback)	When 1, the RX n channel m data comes from the TX n channel m. For proper per channel loopback operations, set the delay offset register bits OFn[2:0] to zero for the streams which are in the loopback mode.
14	$\bar{V}/C$ (Variable/Constant Throughput Delay)	This bit is used to select between the variable (LOW) and constant delay (HIGH) mode on a per-channel basis.
13	PC (Processor Channel)	When 1, the contents of the connection memory are output on the corresponding output channel and stream. Only the lower byte (bit 7 – bit 0) will be output to the TX output pins. When 0, the contents of the connection memory are the data memory address of the switched input channel and stream.
12	CCO (Control Channel Output)	This bit is output on the CCO pin one channel early. The CCO bit for stream 0 is output first.
11	OE (Output Enable)	This bit enables the TX output drivers on a per-channel basis. When 1, the output driver functions normally. When 0, the output driver is in a high-impedance state.
10	Unused	Must be zero for normal operation.
9,8,7 <sup>(1)</sup>	SAB2-0 (Source Stream Address Bits)	The binary value is the number of the data stream for the source of the connection.
6,5 <sup>(1)</sup>	Unused	Must be zero for normal operation.
4-0 <sup>(1)</sup>	CAB4-0 (Source Channel Address Bits)	The binary value is the number of the channel for the source of the connection.

**NOTE:**  
1. If bit 13 (PC) of the corresponding connection memory location is 1 (device in processor mode), then these entire 8 bits (SAB0, bits 6-5, CAB4 - CAB0) are output on the output channel and stream associated with this location.

**ABSOLUTE MAXIMUM RATINGS<sup>(1)</sup>**

Symbol	Parameter	Min.	Max.	Unit
Vcc	Supply Voltage	-0.3	5.0	V
Vi	Voltage on Digital Inputs	GND -0.3	5.5	V
Io	Current at Digital Outputs		20	mA
Ts	Storage Temperature	-65	+125	°C
PD	Package Power Dissipation	—	1	W

**NOTE:**

1. Exceeding these values may cause permanent damage. Functional operation under these conditions is not implied.

**RECOMMENDED DC OPERATING CONDITIONS**

Symbol	Parameter	Min.	Typ.	Max.	Units
Vcc	Positive Supply	3.0	—	3.6	V
VIH	Input HIGH Voltage	2.0	—	Vcc	V
VIL	Input LOW Voltage	GND	—	0.8	V
TOP	Operating Temperature Commercial	-40	—	+85	°C

**NOTE:**

1. Voltages are with respect to ground unless other wise stated.

**DC ELECTRICAL CHARACTERISTICS**

Symbol	Characteristics	Min.	Typ.	Max.	Units
Icc <sup>(1)</sup>	Supply Current @ 2.048 Mb/s	—	7	10	mA
IIL	Input Leakage (input pins)	—	—	15	µA
IBL	Input Leakage (I/O pins)	—	—	50	µA
Ci	Input Pin Capacitance	—	—	10	pF
IoZ	High-impedance Leakage	—	—	5	µA
VOH	Output HIGH Voltage	2.4	—	—	V
VOL	Output LOW Voltage	—	—	0.4	V
Co	Output Pin Capacitance	—	—	10	pF

**NOTE:**

1. Outputs Unloaded.

S1 is open circuit except when testing output levels or high impedance states.  
S2 is switched to VCC or GND when testing output levels or high impedance states.

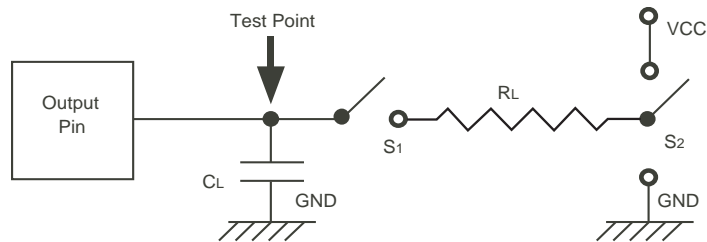

5717 drw06

Figure 6. Output Load

*AC ELECTRICAL CHARACTERISTICS - FRAME PULSE AND CLK*

Symbol	Characteristics	Min.	Typ.	Max.	Units
t <sub>FPW</sub>	Frame Pulse Width (ST-BUS®, GCI) — Bit rate = 2.048 Mb/s	26	—	295	ns
t <sub>FPS</sub>	Frame Pulse Setup time before CLK falling (ST-BUS® or GCI)	5	—	—	ns
t <sub>FPH</sub>	Frame Pulse Hold Time from CLK falling (ST-BUS® or GCI)	10	—	—	ns
t <sub>CP</sub>	CLK Period — Bit rate = 2.048 Mb/s	190	—	300	ns
t <sub>CH</sub>	CLK Pulse Width HIGH — Bit rate = 2.048 Mb/s	85	—	150	ns
t <sub>CL</sub>	CLK Pulse Width LOW — Bit rate = 2.048 Mb/s	85	—	150	ns
t <sub>r</sub> , t <sub>f</sub>	Clock Rise/Fall Time	—	—	10	ns

*AC ELECTRICAL CHARACTERISTICS - SERIAL STREAMS <sup>(1)</sup>*

Symbol	Characteristics	Min.	Typ.	Max.	Unit	Test Conditions
t <sub>SIS</sub>	RX Setup Time	0	—	—	ns	
t <sub>SIH</sub>	RX Hold Time	10	—	—	ns	
t <sub>SOD</sub>	TX Delay – Active to Active	—	—	30	ns	C <sub>L</sub> = 30pF C <sub>L</sub> = 200pF
				40	ns	
t <sub>DZ</sub>	TX Delay – Active to High-Z	—	—	32	ns	R <sub>L</sub> = 1KΩ, C <sub>L</sub> = 200pF
t <sub>ZD</sub>	TX Delay – High-Z to Active	—	—	32	ns	R <sub>L</sub> = 1KΩ, C <sub>L</sub> = 200pF
t <sub>ODE</sub>	Output Driver Enable (ODE) Delay	—	—	32	ns	R <sub>L</sub> = 1KΩ, C <sub>L</sub> = 200pF
t <sub>XCD</sub>	CCO Output Delay	—	—	30	ns	C <sub>L</sub> = 30pF C <sub>L</sub> = 200pF
				40	ns	

NOTE:

1. High Impedance is measured by pulling to the appropriate rail with R<sub>L</sub>, with timing corrected to cancel time taken to discharge C<sub>L</sub>.

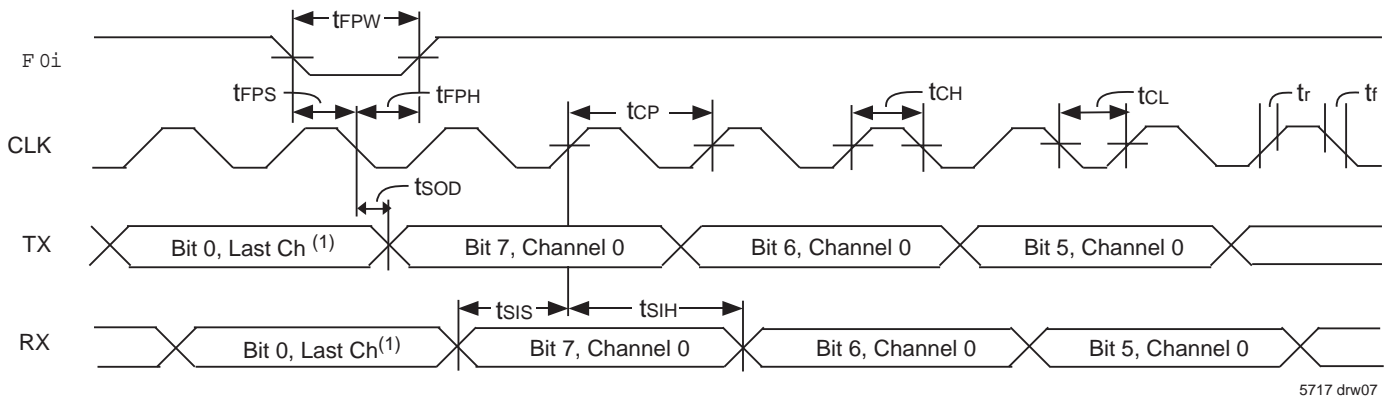

5717 drw07

NOTE:

- 1. last channel = ch 31.

Figure 7. ST-BUS® Timing

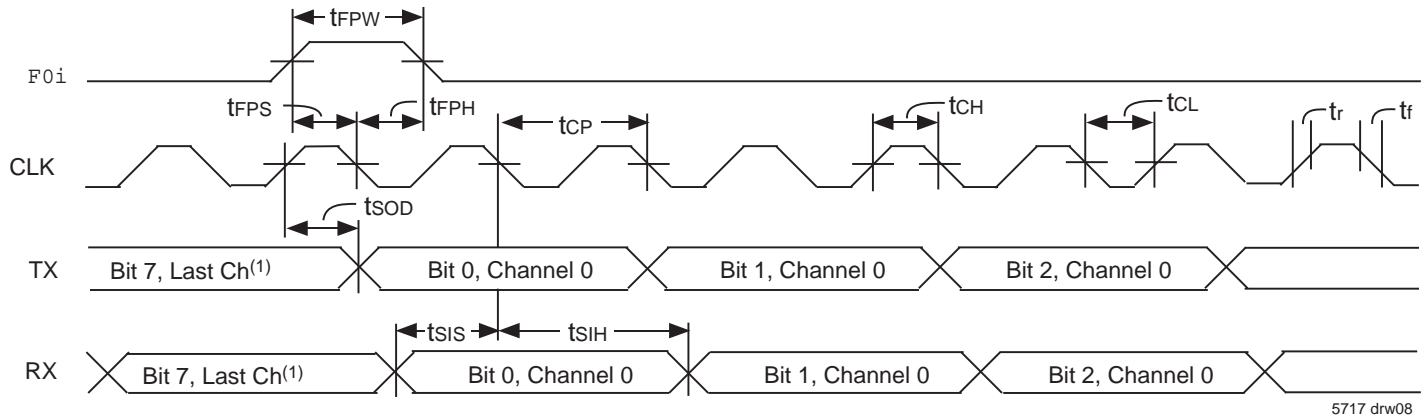

5717 drw08

NOTE:

- 1. last channel = ch 31.

Figure 8. GCI Timing

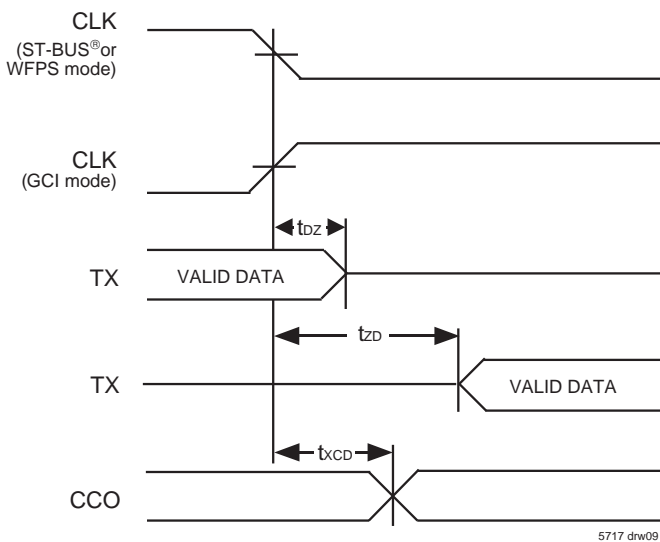

5717 drw09

Figure 9. Serial Output and External Control

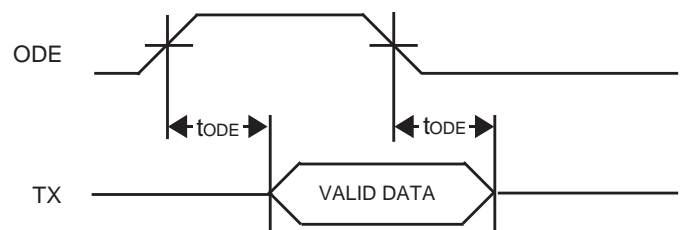

5717 drw10

Figure 10. Output Driver Enable (ODE)

AC ELECTRICAL CHARACTERISTICS - MULTIPLEXED BUS TIMING (INTEL)

Symbol	Parameter	Min.	Typ.	Max.	Units	Test Conditions
tALW	ALE Pulse Width	20			ns	
tADS	Address Setup from ALE falling	3			ns	
tADH	Address Hold from ALE falling	3			ns	
tALRD	$\overline{RD}$ Active after ALE falling	3			ns	
tDDR	Data Setup from $\overline{DTA}$ LOW on Read	5			ns	$C_L = 150\text{pF}$
tCSRW	$\overline{CS}$ Hold after $\overline{RD}/\overline{WR}$	5			ns	
tRW	$\overline{RD}$ Pulse Width (Fast Read)	45			ns	
tCSR	$\overline{CS}$ Setup from $\overline{RD}$	0			ns	
tDHR <sup>(1)</sup>	Data Hold after $\overline{RD}$	10		20	ns	$C_L = 150\text{pF}, R_L = 1\text{K}$
tWW	$\overline{WR}$ Pulse Width (Fast Write)	45			ns	
tALWR	$\overline{WR}$ Delay after ALE falling	3			ns	
tCSW	$\overline{CS}$ Setup from $\overline{WR}$	0			ns	
tDSW	Data Setup from $\overline{WR}$ (Fast Write)	20			ns	
tSWD	Valid Data Delay on Write (Slow Write)			122	ns	
tDHW	Data Hold after $\overline{WR}$ Inactive	5			ns	
tAKD	Acknowledgment Delay: Reading/Writing Registers Reading/Writing Memory			43/43 760/750	ns	$C_L = 150\text{pF}$ $C_L = 150\text{pF}$
tAKH <sup>(1)</sup>	Acknowledgment Hold Time			22	ns	$C_L = 150\text{pF}, R_L = 1\text{K}$

NOTE:

1. High Impedance is measured by pulling to the appropriate rail with  $R_L$ , with timing corrected to cancel time taken to discharge  $C_L$ .

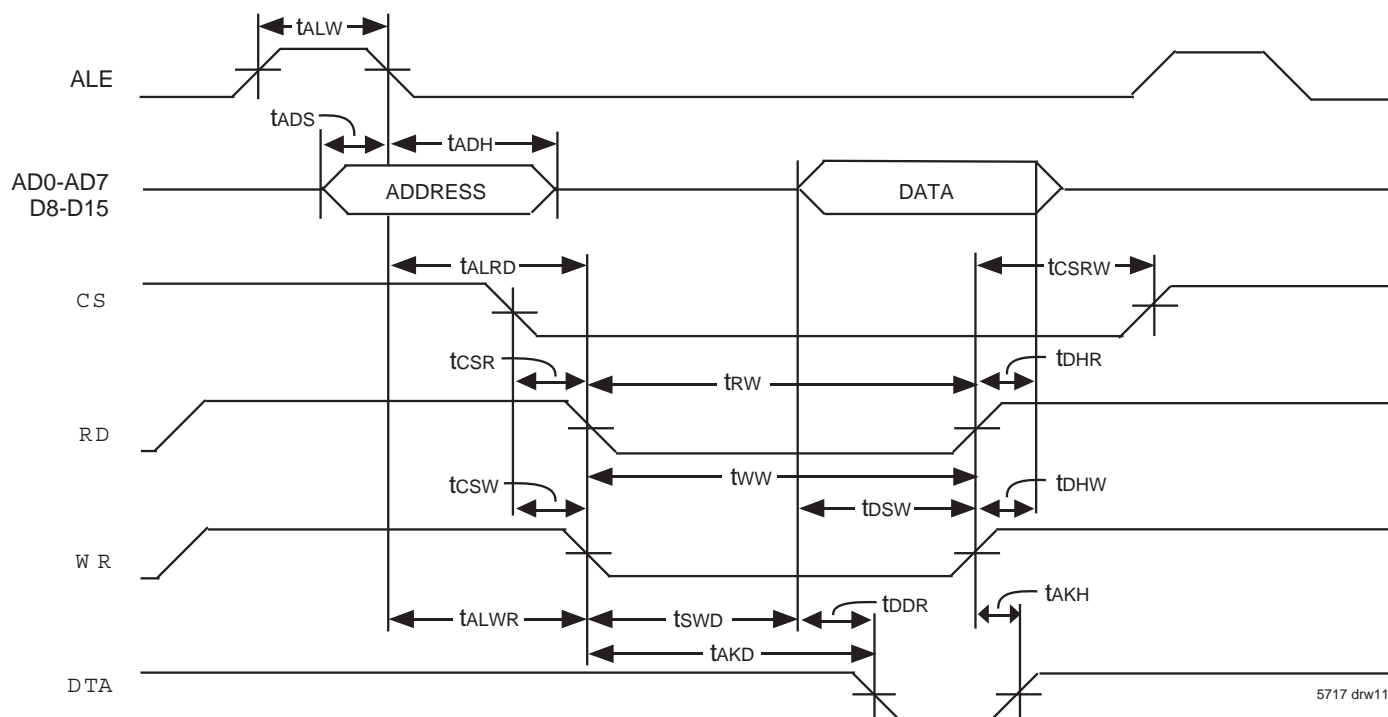

Figure 11. Multiplexed Bus Timing (Intel Mode)



AC ELECTRICAL CHARACTERISTICS - MULTIPLEXED BUS TIMING (MOTOROLA)

Symbol	Parameter	Min.	Typ.	Max.	Units	Test Conditions
t <sub>ASW</sub>	ALE Pulse Width	20			ns	
t <sub>ADS</sub>	Address Setup from AS falling	3			ns	
t <sub>ADH</sub>	Address Hold from AS falling	3			ns	
t <sub>DDR</sub>	Data Setup from $\overline{DTA}$ LOW on Read	5			ns	C <sub>L</sub> = 150pF
t <sub>CSH</sub>	$\overline{CS}$ Hold after DS falling	0			ns	
t <sub>CSS</sub>	$\overline{CS}$ Setup from DS rising	0			ns	
t <sub>DHW</sub>	Data Hold after Write	5			ns	
t <sub>DWS</sub>	Data Setup from DS - Write (Fast Write)	20			ns	
t <sub>SWD</sub>	Valid Data Delay on Write (Slow Write)			122	ns	
t <sub>RWS</sub>	R/ $\overline{W}$ Setup from DS Rising	60			ns	
t <sub>RWH</sub>	R/ $\overline{W}$ Hold from DS Rising	5			ns	
t <sub>DHR</sub> <sup>(1)</sup>	Data Hold after Read	10		20	ns	C <sub>L</sub> = 150pF, R <sub>L</sub> = 1K
t <sub>DSH</sub>	DS Delay after AS falling	10			ns	
t <sub>AKD</sub>	Acknowledgment Delay: Reading/Writing Registers Reading/Writing Memory			43/43 760/750	ns	C <sub>L</sub> = 150pF C <sub>L</sub> = 150pF
t <sub>AKH</sub> <sup>(1)</sup>	Acknowledgment Hold Time			22	ns	C <sub>L</sub> = 150pF, R <sub>L</sub> = 1K

NOTE:

1. High Impedance is measured by pulling to the appropriate rail with R<sub>L</sub>, with timing corrected to cancel time taken to discharge C<sub>L</sub>.

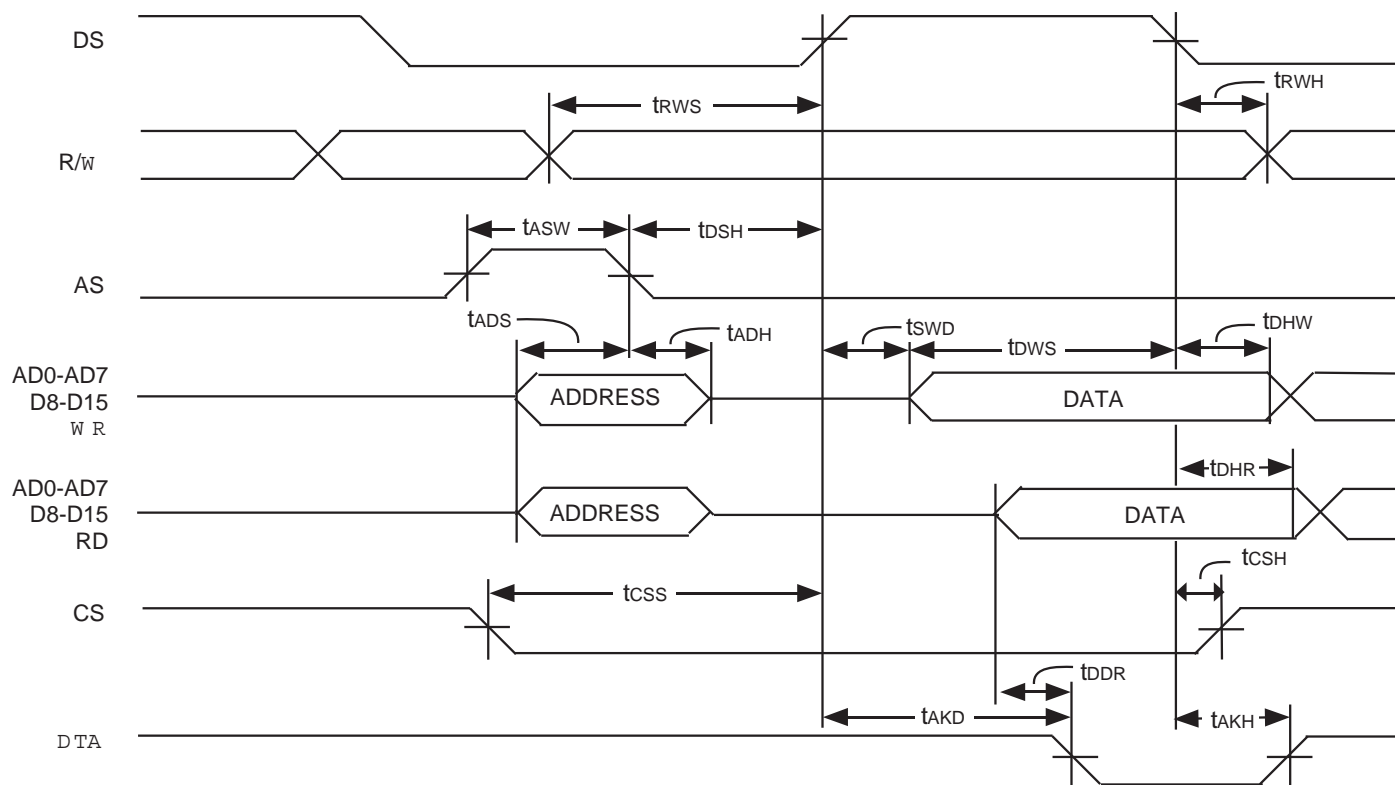

5717 drw12

Figure 12. Multiplexed Bus Timing (Motorola Mode)

AC ELECTRICAL CHARACTERISTICS-MOTOROLA NON-MULTIPLEXED BUS MODE

Symbol	Parameter	Min.	Typ.	Max.	Units	Test Conditions
t <sub>CSS</sub>	CS Setup from DS falling	0			ns	
t <sub>RWS</sub>	R/W Setup from DS falling	10			ns	
t <sub>ADS</sub>	Address Setup from DS falling	2			ns	
t <sub>CSH</sub>	CS Hold after DS rising	0			ns	
t <sub>RWH</sub>	R/W Hold after DS Rising	2			ns	
t <sub>ADH</sub>	Address Hold after DS Rising	2			ns	
t <sub>DDR</sub>	Data Setup from DTA LOW on Read	2			ns	C <sub>L</sub> = 150pF
t <sub>DHR</sub>	Data Hold on Read	10		20	ns	C <sub>L</sub> = 150pF, R <sub>L</sub> = 1K
t <sub>DSW</sub>	Data Setup on Write (Fast Write)	5	—		ns	
t <sub>SWD</sub>	Valid Data Delay on Write (Slow Write)			122	ns	
t <sub>DHW</sub>	Data Hold on Write	5			ns	
t <sub>AKD</sub>	Acknowledgment Delay: Reading/Writing Registers Reading/Writing Memory			43/43 760/750	ns	C <sub>L</sub> = 150pF C <sub>L</sub> = 150pF
t <sub>AKH</sub> <sup>(1)</sup>	Acknowledgment Hold Time			22	ns	C <sub>L</sub> = 150pF, R <sub>L</sub> = 1K

NOTE:

1. High Impedance is measured by pulling to the appropriate rail with R<sub>i</sub>, with timing corrected to cancel time taken to discharge C<sub>L</sub>.

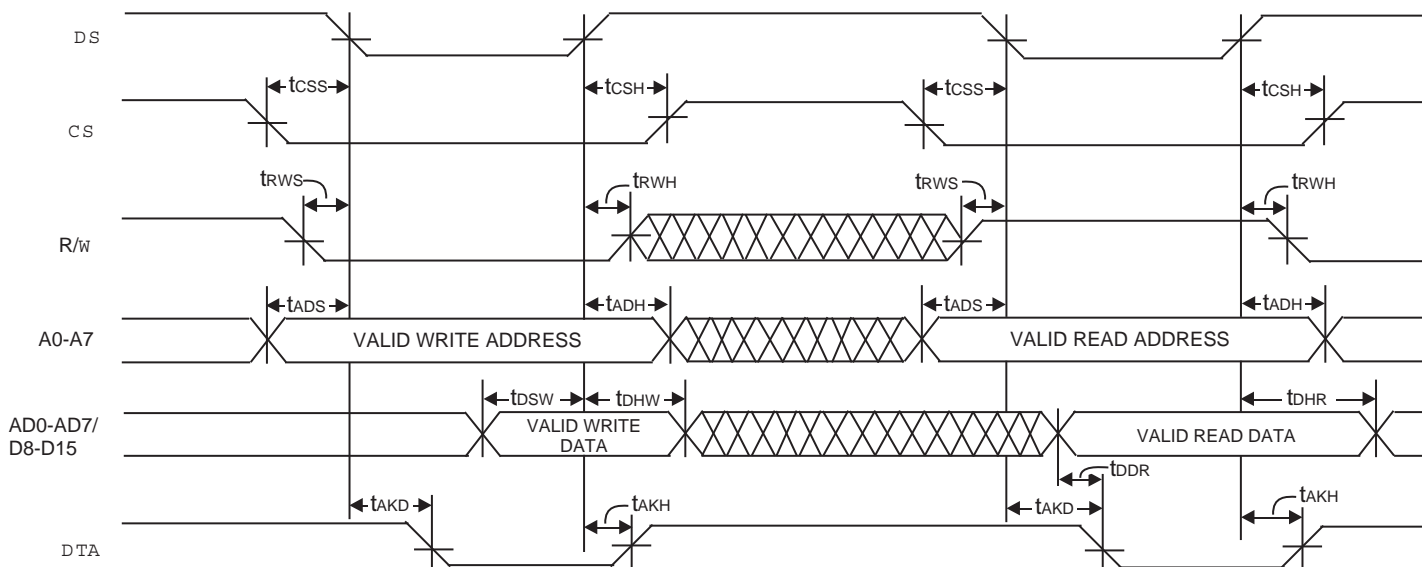

5717 drw13

Figure 13. Motorola Non-Multiplexed Asynchronous Bus Timing

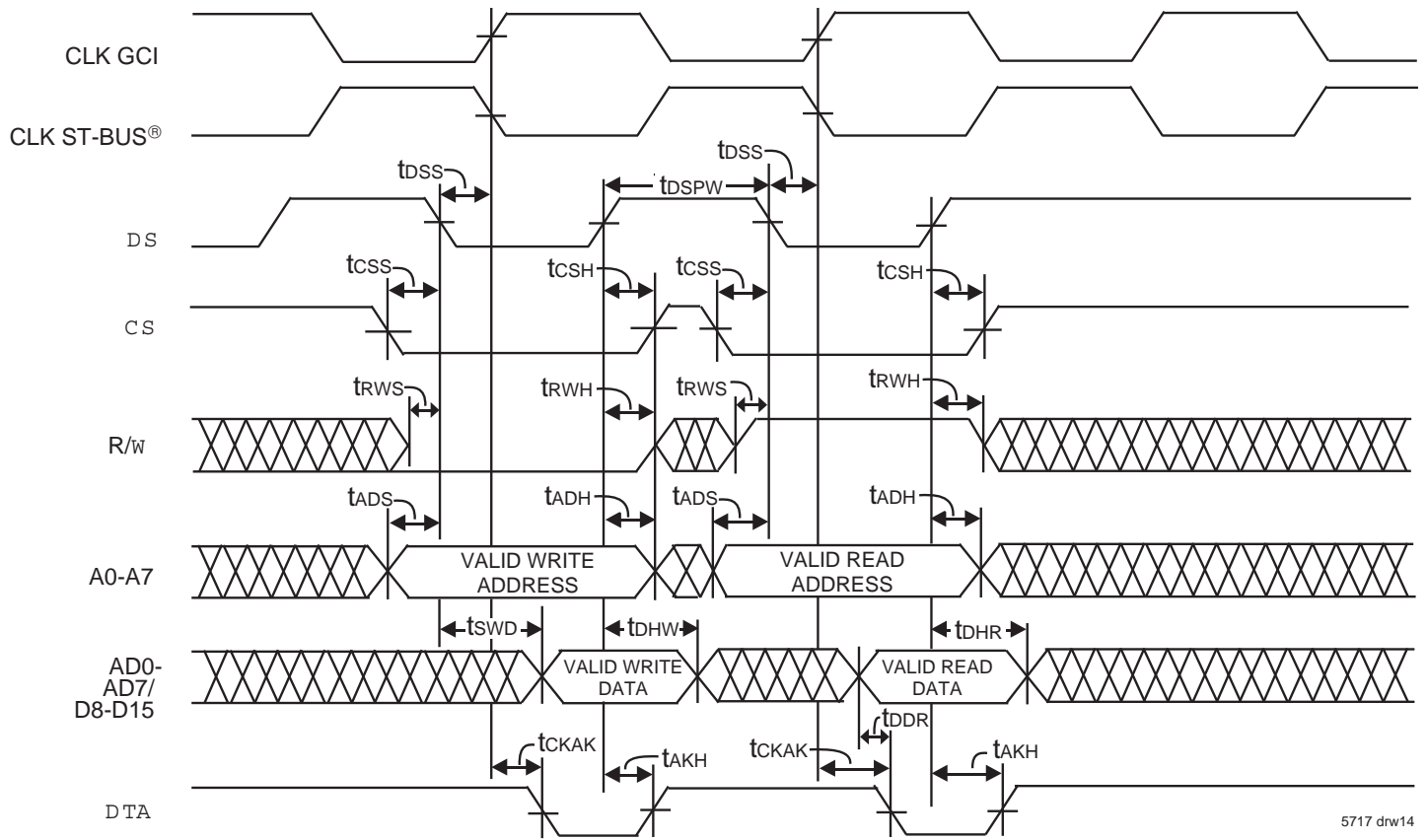

5717 drw14

Figure 14. Motorola Non-Multiplexed Synchronous Bus Timing

## ORDERING INFORMATION

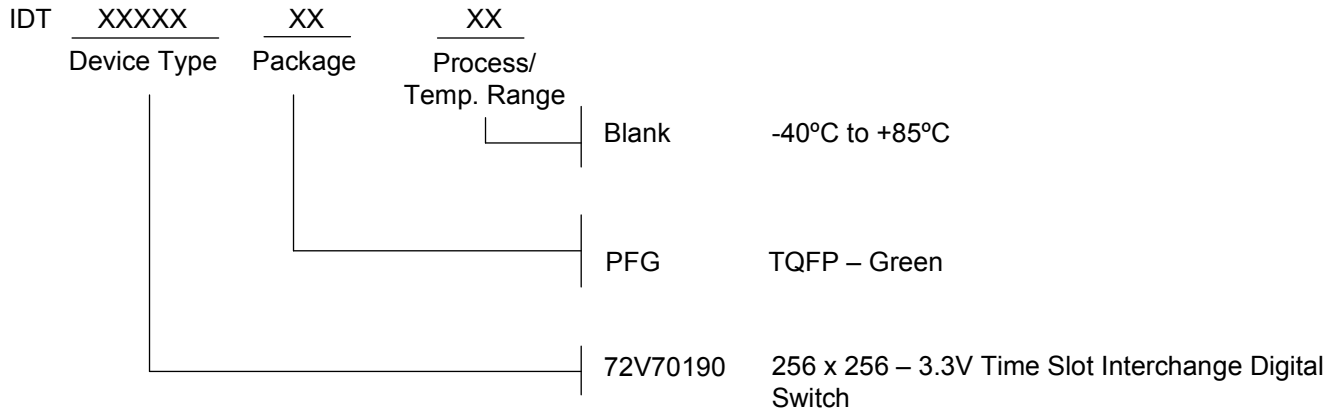

## DATASHEET DOCUMENT HISTORY

5/02/2000	pg. 1	pg 1 and 20 removed TFG package
1/03/2001	pgs. 4, 5, 9, 10, 13, 15, 16, 17, 18 and 19.	
1/25/2001	pgs. 13 and 18.	
08/06/2001	pg. 1	
03/24/2003	pg 1.	
12/07/2004	pgs. 4 and 6.	
12/03/12	pg. 20	



**CORPORATE HEADQUARTER**  
 2975 Stender Way  
 Santa Clara, CA 95054

**for SALES:**  
 800-345-7015 or 408-727-6116  
 fax: 408-492-8649  
 www.idt.com

**for Tech Support:**  
 408-330-1552  
 email: TELECOMhelp@idt.com



## Стандарт Электрон Связь

Мы молодая и активно развивающаяся компания в области поставок электронных компонентов. Мы поставляем электронные компоненты отечественного и импортного производства напрямую от производителей и с крупнейших складов мира.

Благодаря сотрудничеству с мировыми поставщиками мы осуществляем комплексные и плановые поставки широчайшего спектра электронных компонентов.

Собственная эффективная логистика и склад в обеспечивает надежную поставку продукции в точно указанные сроки по всей России.

Мы осуществляем техническую поддержку нашим клиентам и предпродажную проверку качества продукции. На все поставляемые продукты мы предоставляем гарантию .

Осуществляем поставки продукции под контролем ВП МО РФ на предприятия военно-промышленного комплекса России , а также работаем в рамках 275 ФЗ с открытием отдельных счетов в уполномоченном банке. Система менеджмента качества компании соответствует требованиям ГОСТ ISO 9001.

Минимальные сроки поставки, гибкие цены, неограниченный ассортимент и индивидуальный подход к клиентам являются основой для выстраивания долгосрочного и эффективного сотрудничества с предприятиями радиоэлектронной промышленности, предприятиями ВПК и научно-исследовательскими институтами России.

С нами вы становитесь еще успешнее!

### Наши контакты:

**Телефон:** +7 812 627 14 35

**Электронная почта:** [sales@st-electron.ru](mailto:sales@st-electron.ru)

**Адрес:** 198099, Санкт-Петербург,  
Промышленная ул, дом № 19, литера Н,  
помещение 100-Н Офис 331