

MAX40088 Evaluation Kit

Evaluates: MAX40075/MAX40088/
MAX40079/MAX40087

General Description

The MAX40088 evaluation kit (EV kit) is a fully assembled and tested circuit board that contains all the components necessary to evaluate the MAX40075/MAX40088/MAX40079/MAX40087 ICs. The MAX40088 EV kit printed circuit board (PCB) comes installed with MAX40088AUT+ in 6-SOT23 package.

The device is a rail-to-rail output op amp offering 10MHz Gain Bandwidth product (MAX40075/MAX40079) and 42MHz Gain Bandwidth product (MAX40088/MAX40087). The EV kit operates from a single 2.7V to 5.5V DC power supply or from $\pm 1.35V$ to $\pm 2.75V$ split supply.

Features

- +2.7V to +5.5V Supply Voltage Range across V_{DD} and V_{SS}
- 42MHz Gain Bandwidth Product (MAX40088/MAX40087), Gain = 5V/V Stable
- 10MHz Gain Bandwidth Product (MAX40075/MAX40079), Gain = 1V/V Stable
- Ultra-Low Distortion (0.0002% with 1k Ω load)
- Proven PCB Layout
- Fully Assembled and Tested

Ordering Information appears at end of data sheet.

Quick Start

Required Equipment

Before beginning, the following equipment is needed:

- MAX40088 EV kit
- 2.7V to 5.5V, 100mA DC power supply
- Precision voltage calibrator
- Digital multimeter

Procedure

The EV kit is fully assembled and tested. Follow the steps below to verify board operation.

Caution: Do not turn on power supplies until all connections are completed and turn on V_{DD} , V_{SS} supplies before turning on voltage calibrator on the input pins.

- 1) Make sure JU1 jumper is uninstalled and JU2 jumper is in 1-2 position before applying supply voltage.
- 2) Connect positive terminal of the +5V supply to the VDD test point and the GND terminal of supply to the GND test point. Make sure JU3 is in 1-2 position and JU4 is un-installed. JU4 is opened if split supply operation is desired.
- 3) Connect the positive terminal of the precision voltage calibrator to the INP/TP3 test point.
- 4) Connect the DMM to monitor the voltage on the OUTA/TP11 test point.
- 5) Turn on the 5V power supply connected to VDD test point, turn on the precision voltage calibrator on INP/TP3 test point and set 0.1V. Observe the output at the OUTA/TP11 test point on the DMM. DMM should read approximately 1V. Also, vary IN+ voltage between 0V to 0.45V and see if DMM on OUTA test point is showing a gain of 10V/V to the voltage applied on INP test point. Once above step is confirmed, EV kit is tested for functionality.

Detailed Description of Hardware

The MAX40088 EV kit contains the MAX40088 IC, which is rail-to-rail output op amps with low noise and wide bandwidth in 6-SOT23 package. The EV kit operates from a single 2.7V to 5.5V DC power supply. The EV kit is meant to work using split supplies as well where the voltage between V_{DD} and V_{SS} is +2.7V to +5.5V.

Default Application Circuit

The EV kit comes preconfigured in a Non-Inverting amplifier configuration with Gain set as 10V/V.

Op Amp Configurations

The EV kit provides flexibility to easily reconfigure the op amp into any of the three common circuit topologies: inverting amplifier, non-inverting amplifier and Differential amplifier.

These configurations are described in the next few sections.

Noninverting Configuration

The MAX40088 EV kit comes preconfigured as a non-inverting amplifier. The gain is set by the ratio of R8 and R9. The MAX40088 EV kit comes preconfigured for a gain of 10. The output voltage for the non-inverting configuration is given by the equation below:

$$V_{OUTA} = \left(1 + \frac{R8}{R9}\right) V_{INP}$$

Inverting Configuration

To configure the EV kit as an inverting amplifier, remove the shunt 1-2 on JU2 and install a shunt on jumper JU1 on position 1-2 and feed an input signal on the INM pad.

$$V_{OUTA} = -\left(\frac{R8}{R9}\right) V_{INM}$$

Differential Amplifier

To configure the MAX40088 EV kit as a differential amplifier, replace R2, R3, R8, and R9 with appropriate resistors. When $R2 = R8$ and $R3 = R9$, the CMRR of the differential amplifier is determined by the matching of the resistor ratios $R2/R3$ and $R8/R9$.

$$V_{OUTA} = GAIN(V_{INP} - V_{INM})$$

where

$$GAIN = \frac{R8}{R9} = \frac{R2}{R3}$$

Transimpedance Amplifier

To configure the MAX40088 EV kit as a transimpedance amplifier (TIA), short jumper JU1 on 1-2, replace R3, R9 with a 0 ohm resistor and populate R8 pad with 100kΩ resistor. The output voltage of the TIA is the input current multiplied by the feedback resistor:

$$V_{OUT} = (I_{INM} + I_{BIAS-}) \times R8 + V_{OS}$$

where I_{INM} is the input current source applied at the INM test point, I_{BIAS-} is the input bias current into IN- pin, and V_{OS} is the input offset voltage of the op amp. Use capacitor C2 to stabilize the op amp by rolling off high-frequency gain due to a large cable capacitance if desired.

Capacitive Loads

Some applications require driving large capacitive loads. To improve stability of the amplifier in such cases, replace R11 with a suitable resistor value to improve amplifier phase margin.

Table 1. Default Jumper Settings

JUMPER	SHUNT POSITION	DESCRIPTION
JU1	1-2	IN+ to GND
	2-3	IN+ terminated by 50Ω to GND
	Not Installed*	IN+ terminal floating
JU2	1-2*	IN- to GND
	2-3	IN- terminated by 50Ω to GND
	Not Installed	IN- terminal floating
JU3	1-2*	Device in active or normal mode
	2-3	Device in Shutdown mode
JU4	Installed*	Single-supply operation
	Not Installed	Split-supply operation

*Default position.

MAX40088 Evaluation Kit

Evaluates: MAX40075/MAX40088/
MAX40079/MAX40087

Component Suppliers

SUPPLIER	WEBSITE
Murata Electronics	www.murata-northamerica.com

Note: Indicate that you are using the MAX40088 EV kit when contacting these component suppliers.

Ordering Information

PART	TYPE
MAX40088EVKIT#	EV Kit

#RoHS compliant.

MAX40088 Evaluation Kit

Evaluates: MAX40075/MAX40088/
MAX40079/MAX40087

MAX40088 EV Kit Bill of Materials

ITEM	QTY	REF DES	Var Status	MAXINV	MFG PART #	MFG	VALUE	DESCRIPTION
1	2	C4, C6	Pref	20-000U1-P6B	C1608X7R1E104K08 0AA	TDK	0.1UF	CAPACITOR; SMT (0603); CERAMIC CHIP; 0.1UF; 25V; TOL=10%; MODEL=C SERIES; TG=-55 DEGC TO +125 DEGC; TC=X7R
2	2	C5, C7	Pref	20-004U7-L3	C1608X5R1E475K08 0AC; GRM188R61E475KE 11	TDK; MURATA	4.7UF	CAPACITOR; SMT (0603); CERAMIC CHIP; 4.7UF; 25V; TOL=10%; TG=- 55 DEGC TO +85 DEGC; TC=X5R
3	2	GND, GND1	Pref	02-TPMINI5011-00	5011	KEYSTONE	N/A	TEST POINT; PIN DIA=0.125IN; TOTAL LENGTH=0.445IN; BOARD HOLE=0.063IN; BLACK; PHOSPHOR BRONZE WIRE SILVER PLATE FINISH; RECOMMENDED FOR BOARD THICKNESS=0.062IN; NOT FOR COLD TEST
4	3	INM, INP, OUTA	Pref	01- 31532952RFX5P- 21	31-5329-52RFX	AMPHENOL	31-5329- 52RFX	CONNECTOR; FEMALE; THROUGH HOLE; BNC 500HM PCB RECEPTACLE; STRAIGHT; 5PINS
5	3	JU1-JU3	Pref	01-PEC03SAAN3P 21	PEC03SAAN	SULLINS	PEC03SAA N	CONNECTOR; MALE; THROUGH HOLE; BREAKAWAY; STRAIGHT; 3PINS
6	1	JU4	Pref	01-PEC02SAAN2P 21	PEC02SAAN	SULLINS	PEC02SAA N	CONNECTOR; MALE; THROUGH HOLE; BREAKAWAY; STRAIGHT; 2PINS
7	4	R1, R5, R7, R11	Pref	80-0000R-AA6	CRCW06030000Z0	VISHAY DALE	0	RESISTOR; 0603; 0 OHM; 0%; JUMPER; 0.1W; THICK FILM
8	1	R3	Pref	80-0180R-24	CRCW0603180RFK	VISHAY DALE	180	RESISTOR, 0603, 180 OHM, 1%, 100PPM, 0.10W, THICK FILM
9	2	R6, R10	Pref	80-0050R-H9	RG1608N-500-W	SUSUMU CO LTD.	50	RESISTOR; 0603; 50 OHM; 0.05%; 10PPM; 0.10W; THIN FILM
10	1	R8	Pref	80-001K8-24	CRCW06031K80FK	VISHAY DALE	1.8K	RESISTOR, 0603, 1.8K OHM, 1%, 100PPM, 0.10W, THICK FILM
11	1	R9	Pref	80-0200R-24	CRCW06032000FK	VISHAY DALE	200	RESISTOR; 0603; 200 OHM; 1%; 100PPM; 0.10W; THICK FILM
12	4	SU1-SU4	Pref	02- JMPFSTC02SYAN- 00	STC02SYAN	SULLINS ELECTRONI CS CORP.	STC02SYA N	TEST POINT; JUMPER; STR; TOTAL LENGTH=0.256IN; BLACK; INSULATION=PBT CONTACT=PHOSPHOR BRONZE; COPPER PLATED TIN OVERALL
13	4	TP1, TP2, TP4, TP5	Pref	02-TPMINI5001-00	5001	KEYSTONE	N/A	TEST POINT; PIN DIA=0.1IN; TOTAL LENGTH=0.3IN; BOARD HOLE=0.04IN; BLACK; PHOSPHOR BRONZE WIRE SILVER PLATE FINISH; RECOMMENDED FOR BOARD THICKNESS=0.062IN; NOT FOR COLD TEST
14	4	TP3, TP6, TP7, TP11	Pref	02-TPMINI5012-00	5012	KEYSTONE	N/A	TEST POINT; PIN DIA=0.125IN; TOTAL LENGTH=0.445IN; BOARD HOLE=0.063IN; WHITE; PHOSPHOR BRONZE WIRE SILVER PLATE FINISH; RECOMMENDED FOR BOARD THICKNESS=0.062IN; NOT FOR COLD TEST
15	1	U1	Pref	00-SAMPLE-01	MAX40088AUT+	MAXIM	MAX40088 AUT+	EVKIT PART-IC; OPAMP; OZ46; SINGLE 10MHZ; LOW NOISE LOW BIAS CURRENT OP-AMP; PKG. OUTLINE DWG.: 21-0058; SOT23-6
16	1	VDD	Pref	02-TPMINI5010-00	5010	KEYSTONE	N/A	TESTPOINT WITH 1.80MM HOLE DIA; RED; MULTIPURPOSE; NOT FOR COLD TEST
17	1	VSS	Pref	02-TPMINI5013-00	5013	KEYSTONE	N/A	TEST POINT; PIN DIA=0.125IN; TOTAL LENGTH=0.445IN; BOARD HOLE=0.063IN; ORANGE; PHOSPHOR BRONZE WIRE SILVER PLATE FINISH; RECOMMENDED FOR BOARD THICKNESS=0.062IN; NOT FOR COLD TEST
18	1	PCB	-	EPCB4007540088	MAX40088EVKIT#	MAXIM	PCB	PCB:MAX4007540088
TOTAL	38							

DO NOT PURCHASE(DNP)

ITEM	QTY	REF DES	Var Status	MAXINV	MFG PART #	MFG	VALUE	DESCRIPTION
1	3	C1-C3	DNP	N/A	N/A	N/A	OPEN	PACKAGE OUTLINE 0603 NON-POLAR CAPACITOR - EVKIT
2	3	R2, R4, R12	DNP	N/A	N/A	N/A	OPEN	PACKAGE OUTLINE 0603 RESISTOR - EVKIT
TOTAL	6							

PACKOUT (These are purchased parts but not assembled on PCB and will be shipped with PCB)

ITEM	QTY	REF DES	Var Status	MAXINV	MFG PART #	MFG	VALUE	DESCRIPTION
1	1	PACKOUT_BOX	DNI	88-00712-MDM	88-00712-MDM	N/A	?	BOX;+;MEDIUM BROWN 9 3/8" X 7 1/4" X 2 1/2
2	1	PACKOUT_BOX	DNI	87-02159-000	87-02159-000	N/A	?	ESD BAG;+;BAG; STATIC SHIELD 5X8;WESD LOGO
3	1	PACKOUT_BOX	DNI	85-MAXKIT-PNK	85-MAXKIT-PNK	N/A	?	PINK FOAM;FOAM;ANTI-STATIC PE 12inX12inX5MM - PACKOUT
4	1	PACKOUT_BOX	DNI	EVINSERT	EVINSERT	N/A	?	WEB INSTRUCTIONS FOR MAXIM DATA SHEET
5	1	PACKOUT_BOX	DNI	85-84003-006	85-84003-006	N/A	?	LABEL(EV KIT BOX) - PACKOUT
TOTAL	5							

MAX40088 EV Kit Schematic

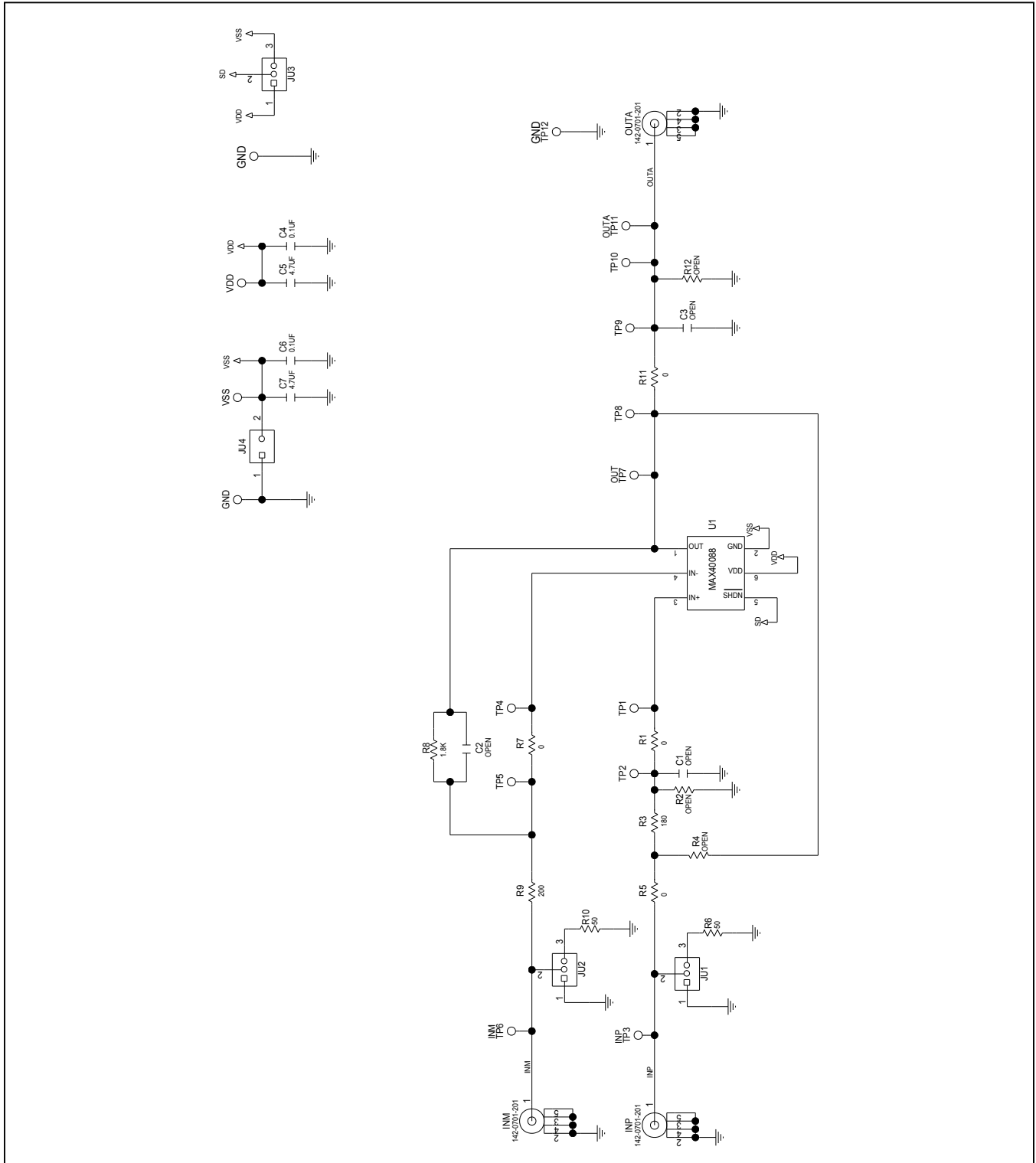

MAX40088 EV Kit PCB Layout Diagrams

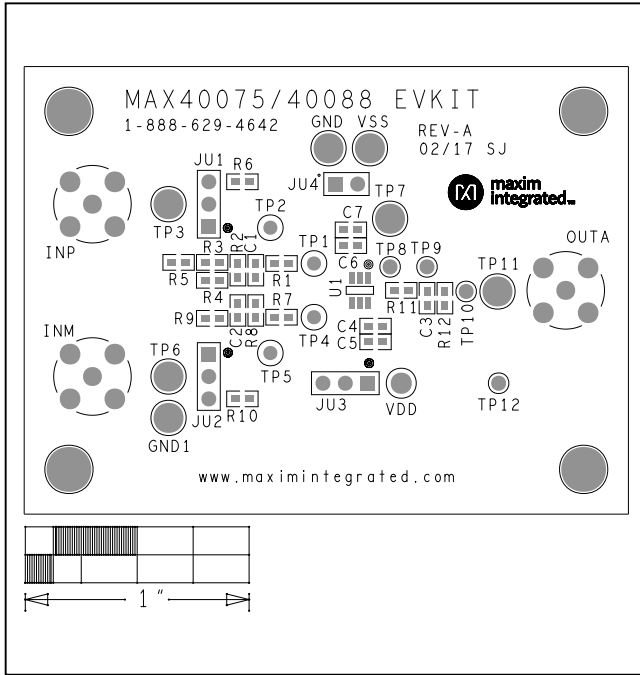

MAX40088 EV Kit—Top Silkscreen

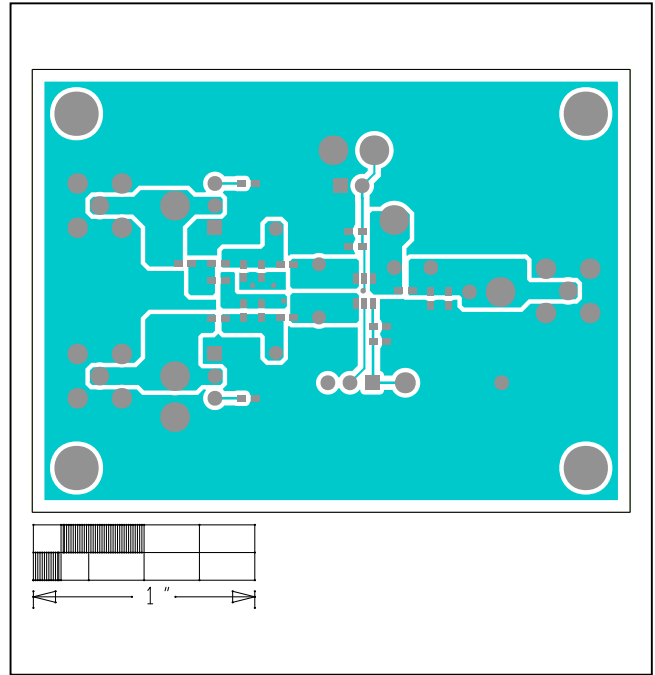

MAX40088 EV Kit—Top

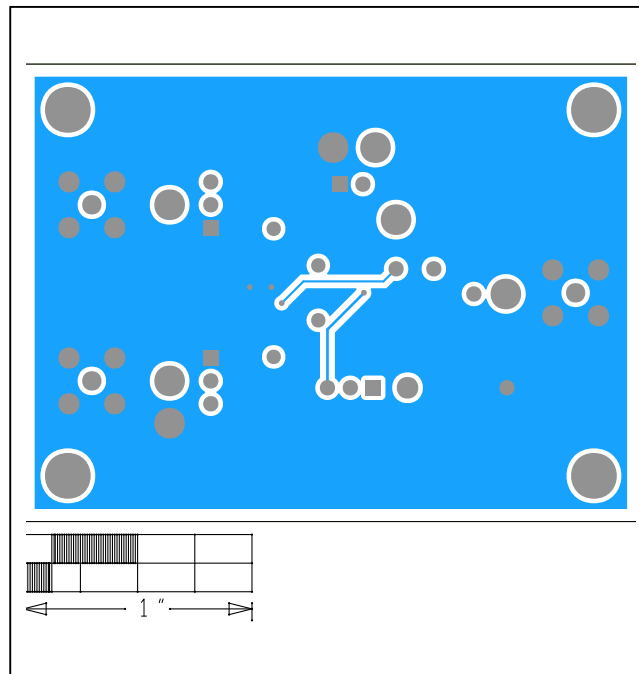

MAX40088 EV Kit—Bottom

Revision History

REVISION NUMBER	REVISION DATE	DESCRIPTION	PAGES CHANGED
0	8/17	Initial release	—
1	12/17	Added MAX40079 and MAX40087 to parts able to be evaluated, <i>General Description</i> and <i>Features</i> sections, and updated schematic	1–7

For pricing, delivery, and ordering information, please contact Maxim Direct at 1-888-629-4642, or visit Maxim Integrated's website at www.maximintegrated.com.

Maxim Integrated cannot assume responsibility for use of any circuitry other than circuitry entirely embodied in a Maxim Integrated product. No circuit patent licenses are implied. Maxim Integrated reserves the right to change the circuitry and specifications without notice at any time.



Стандарт Электрон Связь

Мы молодая и активно развивающаяся компания в области поставок электронных компонентов. Мы поставляем электронные компоненты отечественного и импортного производства напрямую от производителей и с крупнейших складов мира.

Благодаря сотрудничеству с мировыми поставщиками мы осуществляем комплексные и плановые поставки широчайшего спектра электронных компонентов.

Собственная эффективная логистика и склад в обеспечивает надежную поставку продукции в точно указанные сроки по всей России.

Мы осуществляем техническую поддержку нашим клиентам и предпродажную проверку качества продукции. На все поставляемые продукты мы предоставляем гарантию .

Осуществляем поставки продукции под контролем ВП МО РФ на предприятия военно-промышленного комплекса России , а также работаем в рамках 275 ФЗ с открытием отдельных счетов в уполномоченном банке. Система менеджмента качества компании соответствует требованиям ГОСТ ISO 9001.

Минимальные сроки поставки, гибкие цены, неограниченный ассортимент и индивидуальный подход к клиентам являются основой для выстраивания долгосрочного и эффективного сотрудничества с предприятиями радиоэлектронной промышленности, предприятиями ВПК и научно-исследовательскими институтами России.

С нами вы становитесь еще успешнее!

Наши контакты:

Телефон: +7 812 627 14 35

Электронная почта: sales@st-electron.ru

Адрес: 198099, Санкт-Петербург,
Промышленная ул, дом № 19, литера Н,
помещение 100-Н Офис 331