



VINCULUM

BINDING USB TECHNOLOGIES

Future Technology Devices International Ltd

Vinco Touch-Key Shield

Datasheet

Document Reference No.: FT_000514

Version 1.0

Issue Date: 2011-12-21

Vinco Touch-Key Shield is designed to interface to the FTDI Vinco USB development module to demonstrate how the VNC2 device can enable the Open Accessory Mode in compatible Android devices and transfer data to and from the Android device over USB to allow touch key pad operation.

Use of FTDI devices in life support and/or safety applications is entirely at the user's risk, and the user agrees to defend, indemnify and hold FTDI harmless from any and all damages, claims, suits or expense resulting from such use.

1 Introduction

The Vinco Touch-Key is a shield that mates with the FTDI Vinco development module to allow touch pad operation. The shield includes an STMPE821 device, which is an 8-channel GPIO capacitive touch-key sensor. The sensor communicates to the Vinculum-II (VNC2) (on the Vinco module) via I²C protocol.

Vinco is a development module inspired by the Arduino concept and uses the Vinculum-II (VNC2) dual port USB Host/device IC. Vinco uses a VNC2-64Q package to facilitate 38 GPIO options on 0.1" pitch sockets. Vinco is designed as a prototyping platform for VNC2 based designs and applications.

Software libraries for I²C are available with the free with the free [VNC2 IDE](#).

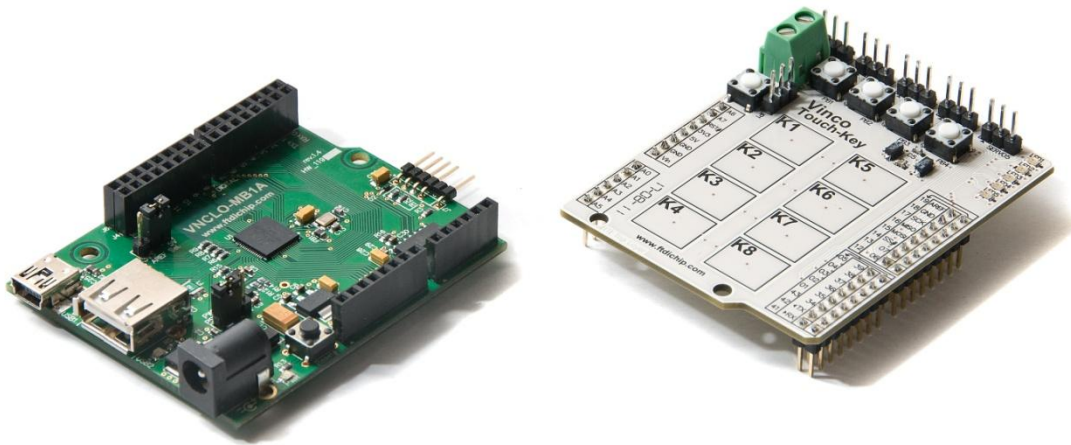

Figure 1.1 – VINCO Development Module and the Touch-Key Shield

1.1 VNC2

VNC2 is the second of FTDI's Vinculum family of embedded dual USB host controller devices. The VNC2 device provides USB host interfacing capability for a variety of different USB device classes including support for BOMS (bulk only mass storage), Printer and HID (human interface devices). For mass storage devices such as USB Flash drives, VNC2 transparently handles the FAT file structure.

Communication with non USB devices, such as a low cost microcontroller, is accomplished via either UART, SPI or parallel FIFO interfaces. VNC2 provides a new, cost effective solution for providing USB Host capability into products that previously did not have the hardware resources available.

VNC2 allows customers to develop their own firmware using the Vinculum II software development tool suite. These development tools provide compiler, assembler, linker and debugger tools complete within an integrated development environment (IDE).

The Vinculum-II VNC2 family of devices are available in Pb-free (RoHS compliant) 32-lead LQFP, 32-lead QFN, 48-lead LQFP, 48-lead QFN, 64-Lead LQFP and 64-lead QFN packages For more information on the ICs refer to [VNC2](#).

1.2 Key Features

The Vinco Touch-Key shield incorporates the following features:

- Utilise STMPE821 chipset with 8 capacitive touch key or GPIOs
- Eight Touch-key capacitance pads operation.
- Four push button switches.
- Five LED's.
- I²C interface with digital controller (VNC2 device) via pin headers
- Mates with the [Vinco Development Platform](#) to enable Open Accessory Mode in Android devices
- Reset switch.
- PWM outputs available
- 5V External/ Internal operation selected by jumper.
- Six I/O pin headers – set as high or low.
- Free software libraries, source codes and drivers are available for customisation purposes
- FTDI Integrated Development Environment (IDE) including code editor, compiler and debugger, which is available as a free download from the [FTDI website](#).

1.3 Part Numbers

Table 1.1 – Vinco Shield Part Numbers

Part Number	Description
VINCO-TOUCH	Vinco Touch-Key shield

Table of Contents

1	Introduction	2
1.1	VNC2.....	2
1.2	Key Features.....	2
1.3	Part Numbers.....	3
2	Touch- Key Block Diagram.....	5
3	Functionality	6
3.1	Power	6
3.2	Pulse Width Modulation Outputs.....	6
3.3	LEDs	6
3.4	Switches	6
4	Pin Out and Signal Description	7
4.1	Module Connector Descriptions.....	7
4.2	Vinco Touch-Key Shield Connectors : Pins and Signal Description	8
5	Firmware /Software	10
5.1	Firmware Support.....	10
5.2	Software Example.....	10
6	Mechanical Dimensions	11
7	Schematic Diagram.....	12
8	Contact Information	13
Appendix A – References		14
Acronyms and Abbreviations		15
Appendix B – List of Figures and Tables		16
List of Tables		16
List of Figures.....		16
Appendix C – Revision History		17

2 Touch- Key Block Diagram

Eight capacitive touch inputs K1 to K8 which connects directly to the STMPE1208S device.

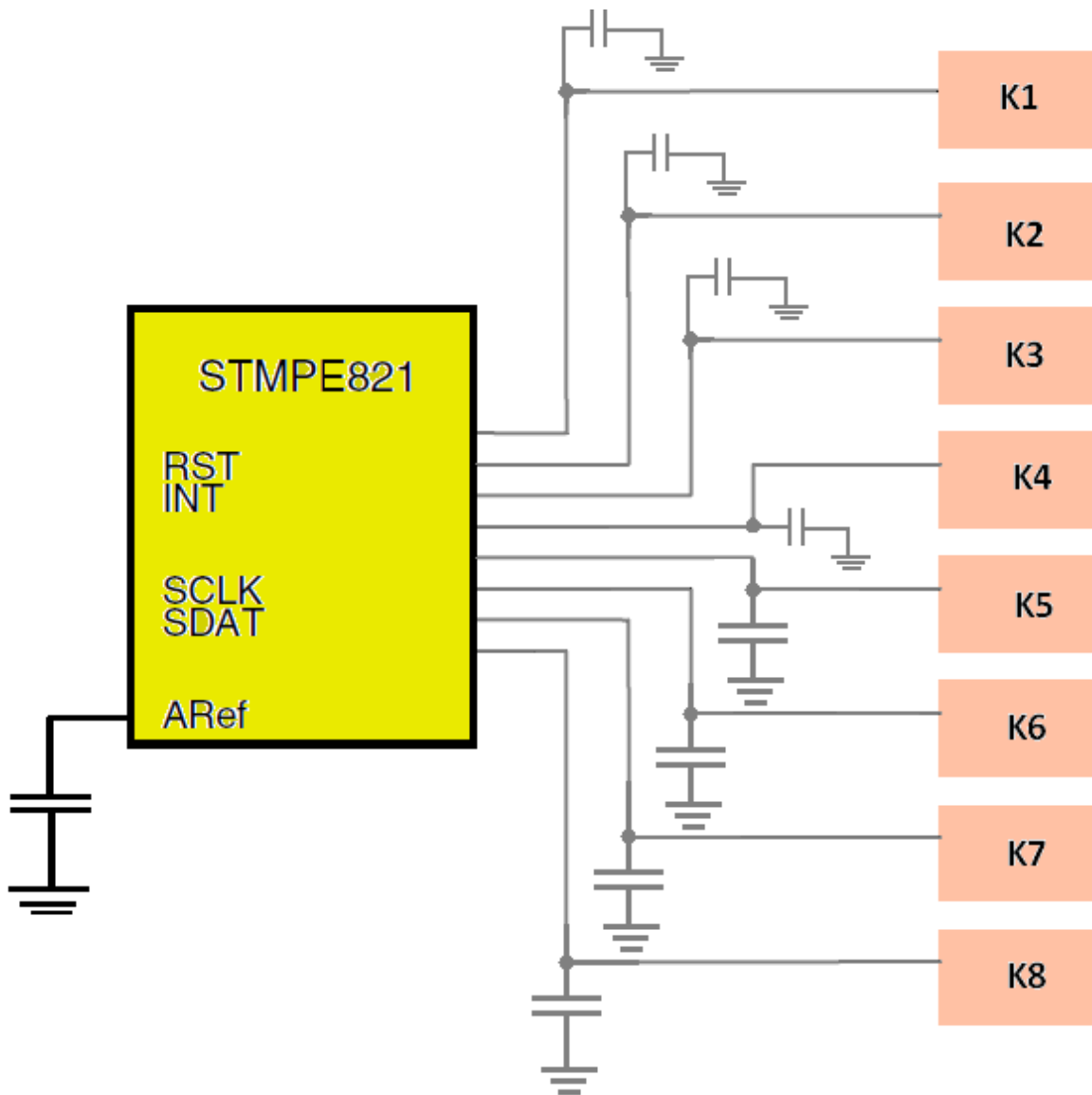

Figure 2.1 Touch-Keys K1:K8 Block Diagram

3 Functionality

3.1 Power

The shield requires a 5V supply to power the PCB. The 5 volts can be provided either from an external supply or from the [Vinco](#) board connections. This selection is made using jumper – JP1:

Jumper Pin	Description
JP1: 1-2	+5V supplied by external VCC via wires connected to CN1.
JP1: 2-3	+5V supplied by connection from the Vinco board.

Table 3.1 – Power control Jumper 1

3.2 Pulse Width Modulation Outputs

Five PWM outputs are available SERV01 to SEV05, each is a three pin header (5V, GND and PWM output from the VNC2)

The PWM can be used to control lamp brightness, electric motor control and servo control etc.

3.3 LEDs

Five LEDs (LED1:LED5) on the Vinco Touch-Key shield are driven from the [Vinco Development Platform](#) through header pins. Each LED is connected via a 470Ω resistor to VCC3V3.

3.4 Switches

SW1 is used to reset the STMPE821 chip.

Four push button switches, PB1 to PB4 provide interrupts to the Vinco board and control LED1:LED4 and 4 LEDs on Android target. There are also 4 push buttons created on Android Tablet.

When a push button is pressed on the Vinco Touch-Key Shield or Android Tablet application, toggles the corresponding LED on the Vinco Touch-Key board and on the Android application.

PWM is implemented on LED5 on the shield. This LED is controlled by Volume control bar on the Android Tablet and demonstrates volume up/down characteristic with varying brightness

4 Pin Out and Signal Description

4.1 Module Connector Descriptions

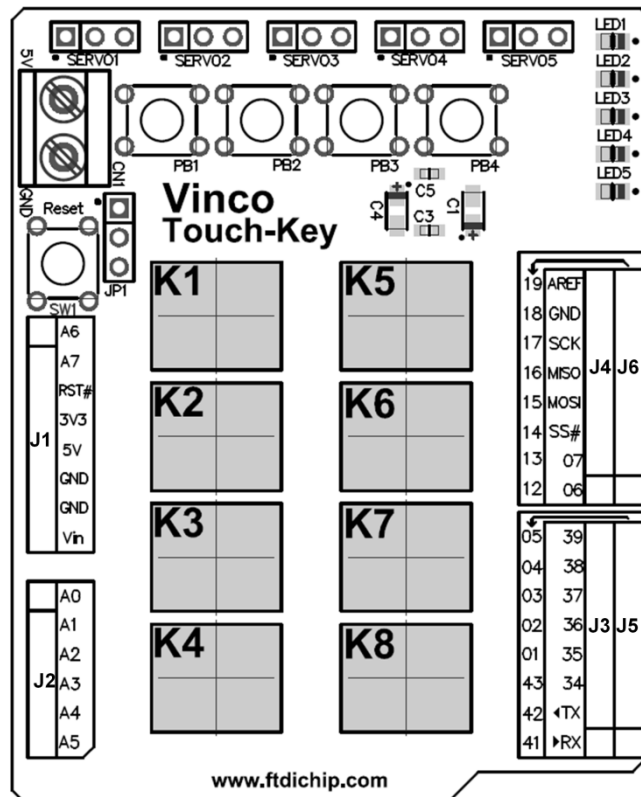

Figure 4.1 – Vinco Touch-Key Layout Diagram

A detailed description of each pin out is given in the next section.

CONNECTOR	FUNCTION
CN1	5 Volt Power Supply – VCC5VEXT
SW1	Reset Switch
PB1 to PB4	Push Button switches 1 to 4 controls LED1 to LED4 and 4 LEDs on Android target
JP1	External/Internal VCC jumper
K1 to K8	Touch keys 1 to 8
SERV01 to SERV05	PWM outputs either logic 1 or logic 0
LED1 to LED5	Light emitting diodes 1 to 5
J1	I/O to the Vinco board
J2	I/O to the Vinco board
J3	I/O to the Vinco board
J4	I/O to the Vinco board
J5	I/O to the Vinco board
J6	I/O to the Vinco board

Table 4.1 – Vinco Touch-Key Connector Descriptions

4.2 Vinco Touch-Key Shield Connectors : Pins and Signal Description

The following **Table 4.2** detailed signal description of each pin out

Touch-Key Pin No.	Name	Type	Description	Routed to VNC2 Pin on VINCO Module
CN1-1	A6	Input	5 Volt supply	N/A
CN1-2	A7	Input	Gnd	N/A
SW1-1	RESET#	Input	Reset	N/A
SW1-2	Gnd		Gnd	N/A
JP1-1	VCC5EXT		Shield external powered	N/A
JP1-2	VCC5V		Shield USB powered	N/A
JP1-3	VINCO-VCC5V		Shield VINCO powered	N/A
<hr/>				
J1-1	A6	I/O	NOT IN USE	
J1-2	A7	I/O	NOT IN USE	
J1-3	RESET#	Output	Reset for the VNC2-64Q	9
J1-4	VCC3V3	PWR input	NOT IN USE	
J1-5	VCC5V	Power output	5V input to power shield	N/A
J1-6	GND	GND	GND for PCB	1, 6, 8, 30, 35, 53, 64
J1-7	GND	GND	GND for PCB	1, 6, 8, 30, 35, 53, 64
J1-8	VCCIN	PWR Input	NOT IN USE	
<hr/>				
J2-1	-	-	NOT IN USE	
J2-2	-		NOT IN USE	
J2-3	-	-	NOT IN USE	
J2-4	-	-	NOT IN USE	
J2-5	-	-	NOT IN USE	
J2-6	-	-	NOT IN USE	
<hr/>				
J3-1	IOBUS33	I/O	NOT IN USE	
J3-2	IOBUS32	I/O	NOT IN USE	
J3-3	IOBUS34	I/O	NOT IN USE	
J3-4	IOBUS35	I/O	NOT IN USE	
J3-5	IOBUS36	Output	LED4	
J3-6	IOBUS37	Output	LED3	
J3-7	IOBUS38	Output	LED2	
J3-8	IOBUS39	Output	LED1	
<hr/>				
J4-1	IOBUS6	Output	SERV05	
J4-2	IOBUS7	I/O	NOT IN USE	
J4-3	SS#	I/O	NOT IN USE	

Touch-Key Pin No.	Name	Type	Description	Routed to VNC2 Pin on VINCO Module
J4-4	MOSI	Input	NOT IN USE	20
J4-5	MISO	Output	NOT IN USE	22
J4-6	SCLK	Input	NOT IN USE	19
J4-7	GND	GND	GND for PCB	1, 6, 8, 30, 35, 53, 64
J4-8	AREF	I/O	NOT IN USE	
J5-1	IOBUS41	I/O	NOT IN USE	
J5-2	IOBUS42	I/O	NOT IN USE	
J5-3	IOBUS43	I/O	NOT IN USE	
J5-4	IOBUS1	Output	LED5	
J5-5	IOBUS2	Output	SERV01	
J5-6	IOBUS3	Output	SERV02	
J5-7	IOBUS4	Output	SERV03	
J5-8	IOBUS5	Output	SERV04	
J6-1	IOBUS12	Output	INT#	
J6-2	IOBUS13	Output	SCL - I2C Clock	
J6-3	IOBUS14	Input/Output	SDA - I2C Data	
J6-4	IOBUS15	Input	Reset for the STMPE821	
J6-5	IOBUS16	Input	Push Button 1	
J6-6	IOBUS17	Input	Push Button 2	
J6-7	IOBUS18	Input	Push Button3	
J6-8	IOBUS19	Input	Push Button 4	

Table 4.2 – Pin Signal Descriptions

5 Firmware /Software

5.1 Firmware Support

Firmware libraries and example applications to demonstrate using this shield with the Vinco module are available for download with the VNC2 IDE from Toolchain revision 1.4.2 onwards ([VNC2 tools](#)).

5.2 Software Example

The principal reason that the Vinco Touch-Key shield was designed was to demonstrate how the VNC2 device can enable the Open Accessory Mode in compatible Android devices and transfer data to and from the Android device over USB. The full code and explanation of the project is available in the application note AN_196 Accessing Android Open Accessory Mode with Vinco Development Platform.

6 Mechanical Dimensions

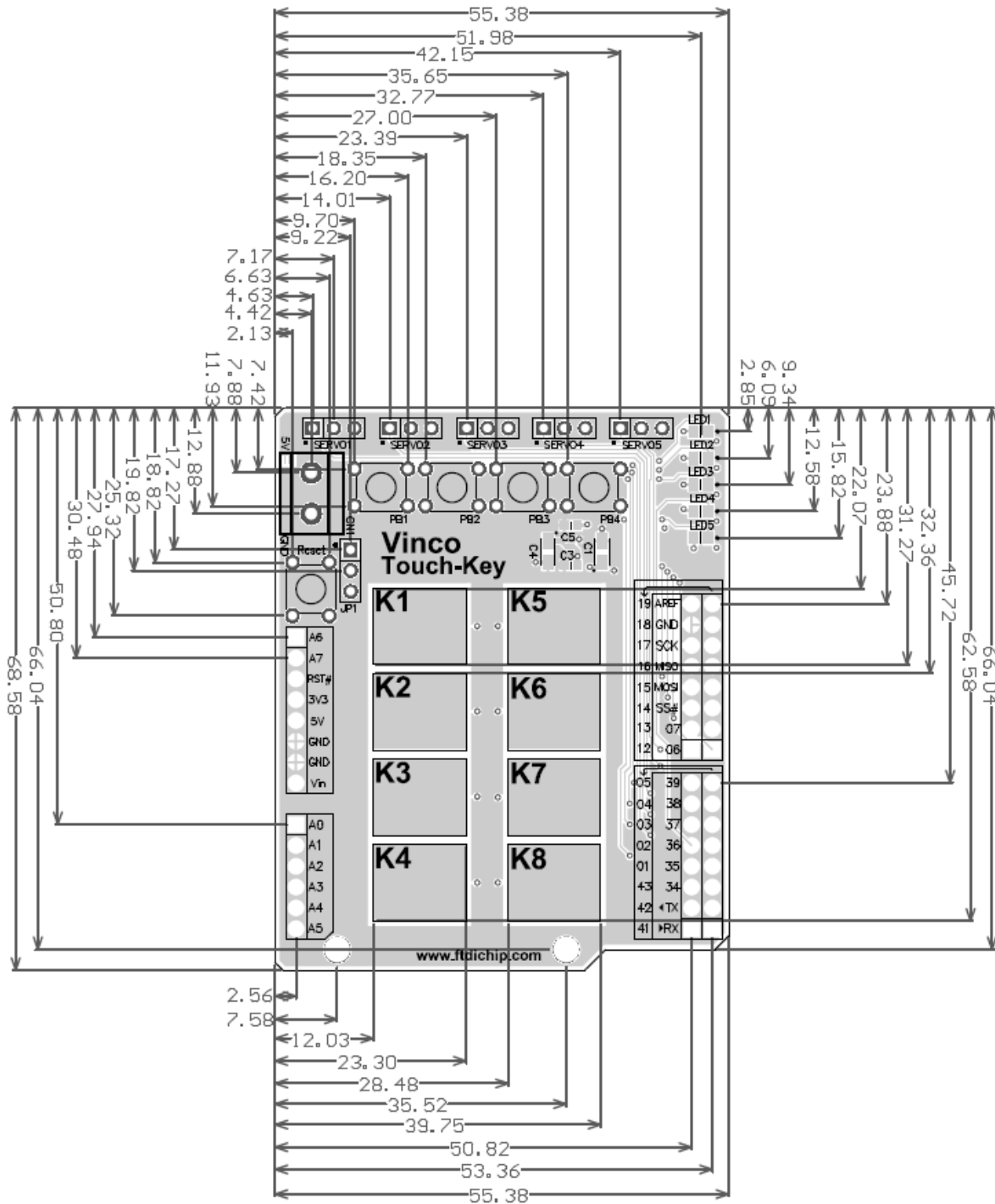

Figure 6.1 – Vinco Touch-Key Dimensions

All dimensions are in mm
 PCB Tolerance +/- 0.10

8 Contact Information

Head Office – Glasgow, UK

Future Technology Devices International Limited
Unit 1, 2 Seaward Place, Centurion Business Park
Glasgow G41 1HH
United Kingdom
Tel: +44 (0) 141 429 2777
Fax: +44 (0) 141 429 2758

E-mail (Sales) sales1@ftdichip.com
E-mail (Support) support1@ftdichip.com
E-mail (General Enquiries) admin1@ftdichip.com

Branch Office – Hillsboro, Oregon, USA

Future Technology Devices International Limited (USA)
7235 NW Evergreen Parkway, Suite 600
Hillsboro, OR 97123-5803
USA
Tel: +1 (503) 547 0988
Fax: +1 (503) 547 0987

E-Mail (Sales) us.sales@ftdichip.com
E-Mail (Support) us.support@ftdichip.com
E-Mail (General Enquiries) us.admin@ftdichip.com

Branch Office – Taipei, Taiwan

Future Technology Devices International Limited
(Taiwan)
2F, No. 516, Sec. 1, NeiHu Road
Taipei 114
Taiwan, R.O.C.
Tel: +886 (0) 2 8791 3570
Fax: +886 (0) 2 8791 3576

E-mail (Sales) tw.sales1@ftdichip.com
E-mail (Support) tw.support1@ftdichip.com
E-mail (General Enquiries) tw.admin1@ftdichip.com

Branch Office – Shanghai, China

Future Technology Devices International Limited (China)
Room 408, 317 Xianxia Road,
Shanghai, 200051
China
Tel: +86 21 62351596
Fax: +86 21 62351595

E-mail (Sales) cn.sales@ftdichip.com
E-mail (Support) cn.support@ftdichip.com
E-mail (General Enquiries) cn.admin@ftdichip.com

Web Site

<http://ftdichip.com>

Distributor and Sales Representatives

Please visit the Sales Network page of the [FTDI Web site](#) for the contact details of our distributor(s) and sales representative(s) in your country.

Neither the whole nor any part of the information contained in, or the product described in this manual, may be adapted or reproduced in any material or electronic form without the prior written consent of the copyright holder. This product and its documentation are supplied on an as-is basis and no warranty as to their suitability for any particular purpose is either made or implied. Future Technology Devices International Ltd will not accept any claim for damages howsoever arising as a result of use or failure of this product. Your statutory rights are not affected. This product or any variant of it is not intended for use in any medical appliance, device or system in which the failure of the product might reasonably be expected to result in personal injury. This document provides preliminary information that may be subject to change without notice. No freedom to use patents or other intellectual property rights is implied by the publication of this document. Future Technology Devices International Ltd, Unit 1, 2 Seaward Place, Centurion Business Park, Glasgow G41 1HH, United Kingdom. Scotland Registered Company Number: SC136640

Appendix A – References

The following VNC2 documents and the full Vinculum-II Toolchain software suite can be downloaded by clicking on the appropriate links below:

Application note AN_196	Accessing Android Open Accessory Mode with Vinco Development Platform
Application note AN_181	Accessing Android Open Accessory with Vinculum-II
Technical note TN_108	Vinculum Chipset Feature Comparison
Technical note TN_118	Vinculum-II Errata Technical Note
Application note AN_118	Migrating Vinculum Designs From VNC1L to VNC2-48L1A
Application note AN_137	Vinculum-II IO Cell Description
Application note AN_138	Vinculum-II Debug Interface Description
Application note AN_139	Vinculum-II IO Mux Explained
Application note AN_140	Vinculum-II PWM Example
Application note AN_142	Vinculum-II Toolchain Getting Started Guide
Application note AN_144	Vinculum-II IO Mux Configuration Utility User Guide
Application note AN_145	Vinculum-II Toolchain Installation Guide
Application note AN_151	Vinculum-II User Guide
VNC2 FTDI Web Page	Vinculum-II Web Page
STMPE821 datasheet	DATASHEET CD00186453
Vinco datasheet	Vinco Datasheet
VNC2 datasheet	Vinculum-II Datasheet
IDE Toolchain	Vinculum-II Toolchain

Acronyms and Abbreviations

Terms	Description
USB	Universal Serial Bus
FIFO	First In First Out
SPI	Serial Peripheral Interface
PWM	Pulse Width Modulation
GPIO	General Purpose Input Output
I/O	Input / Output
VNC1L	Vinculum-I
VNC2	Vinculum-II
DMA	Direct Memory Access
IDE	Integrated Development Environment
BOMS	Bulk Only Mass Storage
UART	Universal Asynchronous Receiver/Transmitter
SIE	Serial Interface Engine
CPU	Central Processing Unit
SoC	System-on-a-chip
FAT	File Allocation Table
RTOS	Real Time Operating System
VOS	Vinculum Operating System
OSI	Open System Interconnection
MOSI	Master Out Slave In
MISO	Master In Slave Out
SE0	Single Ended Zero
EMCU	Embedded Micro Central Processing Unit
FPGA	Field Programmable Gate Array

Appendix B – List of Figures and Tables

List of Tables

Table 0.1 – Vinco Shield Part Numbers	3
Table 3.1 – Power control Jumper 1	6
Table 4.1 – Vinco Touch-Key Connector Descriptions.....	7
Table 4.2 – Pin Signal Descriptions	9

List of Figures

Figure 1.1 – VINCO Development Module and the Touch-Key Shield.....	2
Figure 2.1 Touch-Keys K1:K8 Block Diagram.....	5
Figure 4.1 – Vinco Touch-Key Layout Diagram.....	7
Figure 6.1 – Vinco Touch-Key Dimensions.....	11
Figure 7.1 – Vinco Touch-Schematic Diagram	12

Appendix C – Revision History

Document Title: Vinco Touch-Key Datasheet
Document Reference No.: FT_000514
Clearance No.: FTDI#
Document Folder: [Vinculum-II](#)
Document Feedback: [Send Feedback](#)

Revision	Changes	Date
1.0	First release	2011-12-21



Стандарт Электрон Связь

Мы молодая и активно развивающаяся компания в области поставок электронных компонентов. Мы поставляем электронные компоненты отечественного и импортного производства напрямую от производителей и с крупнейших складов мира.

Благодаря сотрудничеству с мировыми поставщиками мы осуществляем комплексные и плановые поставки широчайшего спектра электронных компонентов.

Собственная эффективная логистика и склад в обеспечивает надежную поставку продукции в точно указанные сроки по всей России.

Мы осуществляем техническую поддержку нашим клиентам и предпродажную проверку качества продукции. На все поставляемые продукты мы предоставляем гарантию .

Осуществляем поставки продукции под контролем ВП МО РФ на предприятия военно-промышленного комплекса России , а также работаем в рамках 275 ФЗ с открытием отдельных счетов в уполномоченном банке. Система менеджмента качества компании соответствует требованиям ГОСТ ISO 9001.

Минимальные сроки поставки, гибкие цены, неограниченный ассортимент и индивидуальный подход к клиентам являются основой для выстраивания долгосрочного и эффективного сотрудничества с предприятиями радиоэлектронной промышленности, предприятиями ВПК и научно-исследовательскими институтами России.

С нами вы становитесь еще успешнее!

Наши контакты:

Телефон: +7 812 627 14 35

Электронная почта: sales@st-electron.ru

Адрес: 198099, Санкт-Петербург,
Промышленная ул, дом № 19, литера Н,
помещение 100-Н Офис 331