

Simple 90V, 20mA, Temperature Compensated Constant Current LED Driver IC

Features

- ▶ 5.0 to 90V operating range (V_{A-B})
- ▶ 20mA $\pm 10\%$ at 5.0 - 90V
- ▶ 0.01%/°C typical temperature coefficient
- ▶ Available in TO-243AA (SOT-89), TO-252 (D-PAK), & TO-92 packages
- ▶ Can be paralleled for higher current

Applications

- ▶ LED driver
- ▶ Industrial lamp indicators
- ▶ Signage
- ▶ Accent lighting
- ▶ Automotive
- ▶ Constant current source
- ▶ Constant current sink

General Description

The Supertex CL2 is a high voltage, temperature compensated, constant current source. The device is trimmed to provide a constant current of 20mA $\pm 10\%$ at an input voltage of 5.0 - 90V. The device can be used as a two terminal constant current source or constant current sink.

A typical application for the CL2 is to drive LEDs with a constant current of 20mA. Multiple CL2s can also be used in parallel to provide higher currents such as 40mA, 60mA or 80mA. The device is available in TO-243AA (SOT-89), TO-252 (D-PAK), and TO-92 packages.

Typical Application Circuit

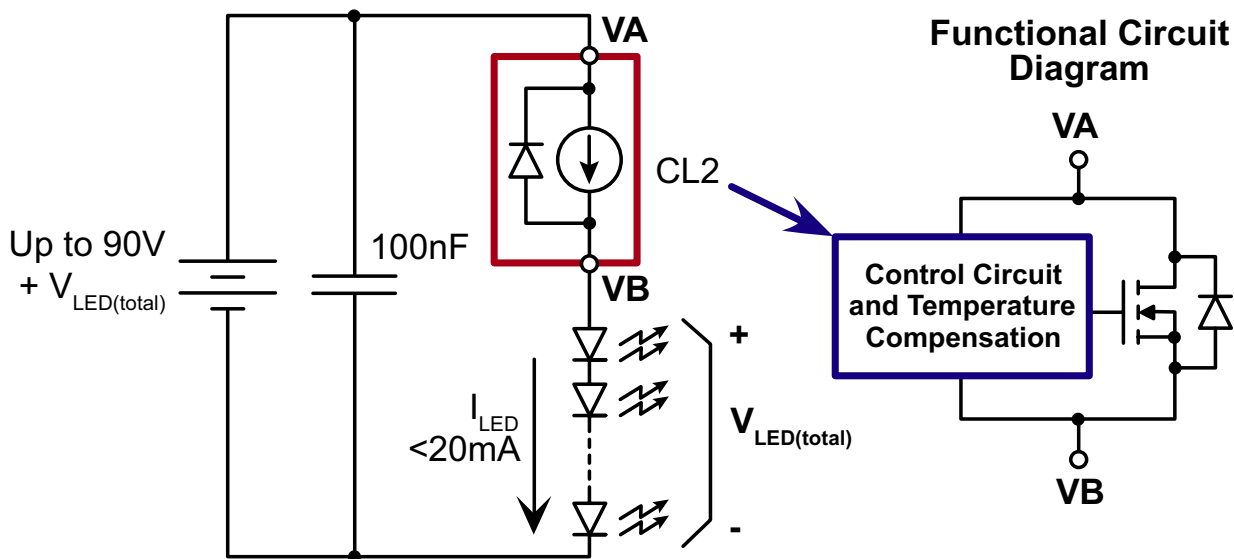

Ordering Information

Part Number	Package Options	Packing
CL2K4-G	TO-252 (D-PAK)	2000/Reel
CL2N3-G	TO-92	1000/Bag
CL2N3-G P002	TO-92	2000/Reel
CL2N3-G P003	TO-92	2000/Reel
CL2N3-G P005	TO-92	2000/Reel
CL2N3-G P013	TO-92	2000/Reel
CL2N3-G P014	TO-92	2000/Reel
CL2N8-G	TO-243AA (SOT-89)	2000/Reel

-G indicates package is RoHS compliant ('Green')
 Refer to 'P0xx' Tape & Reel Specs for P002, P003, P005, P013, and P014 TO-92 Taping Specifications and Winding Styles

Absolute Maximum Ratings

Parameter	Value
Operating voltage, V_{A-B}	100V
Operating junction temperature, T_j	-40°C to +125°C
Storage temperature, T_s	-55°C to +150°C

Absolute Maximum Ratings are those values beyond which damage to the device may occur. Functional operation under these conditions is not implied. Continuous operation of the device at the absolute rating level may affect device reliability. All voltages are referenced to device ground.

Typical Thermal Characteristics

Package	Power Dissipation @ $T_A = 25^\circ\text{C}$ (W)	θ_{ja} (°C/W)
TO-252	2.0*	81*
TO-92	0.6	132
TO-243AA	1.3*	133*

* Mounted on FR4 board; 25mm x 25mm x 1.57mm

Electrical Characteristics ($T_A = 25^\circ\text{C}$ unless otherwise specified)

Sym	Parameter	Min	Typ	Max	Units	Conditions
V_{A-B}	Operating voltage	5.0	-	90	V	---
I_{A-B}	Current regulation	18.0	20	22	mA	$V_{A-B} = 5.0\text{V} - 90\text{V}$
$\Delta I_{A-B}/\Delta T$	I_{A-B} temperature coefficient	-	0.01	-	%/°C	$V_{A-B} = 45\text{V}, T_j = -40^\circ\text{C}$ to $+100^\circ\text{C}$
T_j	Operating junction temperature	-40	-	125	°C	---
R_{A-B}	Dynamic resistance	-	300	-	kΩ	---



Pin Configurations



TO-252 (D-PAK) (K4)



TO-92 (N3)

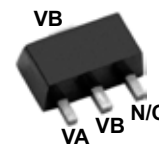

TO-243AA (SOT-89) (N8)

Product Marking

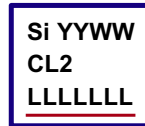

YY = Year Sealed
 WW = Week Sealed
 L = Lot Number
 _____ = "Green" Packaging

TO-252 (D-PAK) (K4)

Package may or may not include the following marks: Si or



YY = Year Sealed
 WW = Week Sealed
 _____ = "Green" Packaging

TO-92 (N3)

Package may or may not include the following marks: Si or

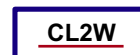

W = Code for week sealed
 _____ = "Green" Packaging

TO-243AA (SOT-89) (N8)

Package may or may not include the following marks: Si or

Functional Circuit Diagram

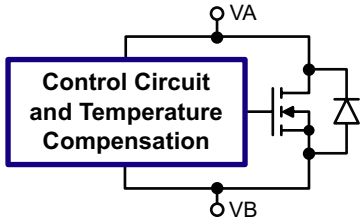

Equivalent Block Diagram

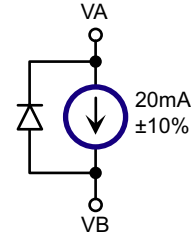

Temperature Characteristics

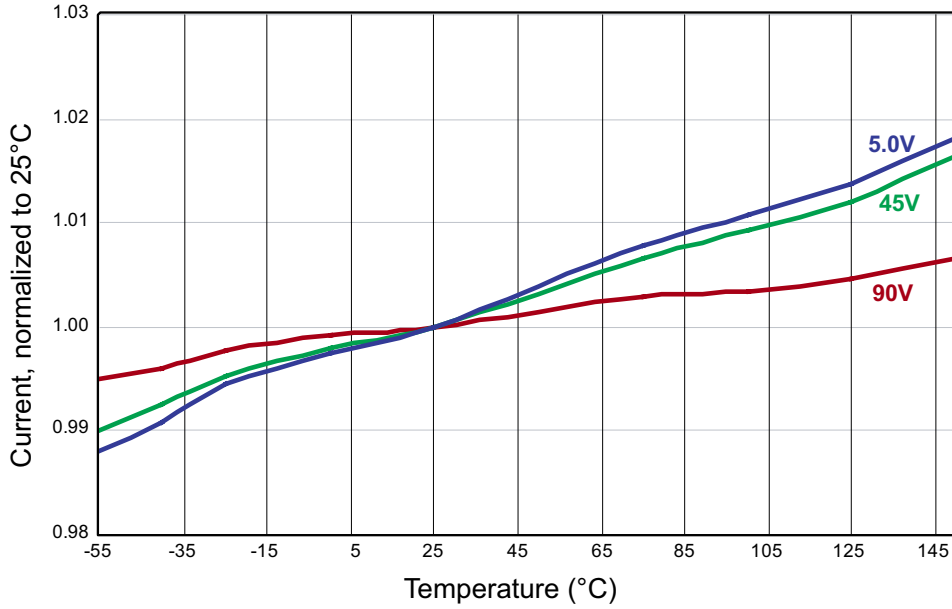

Output Current vs Voltage

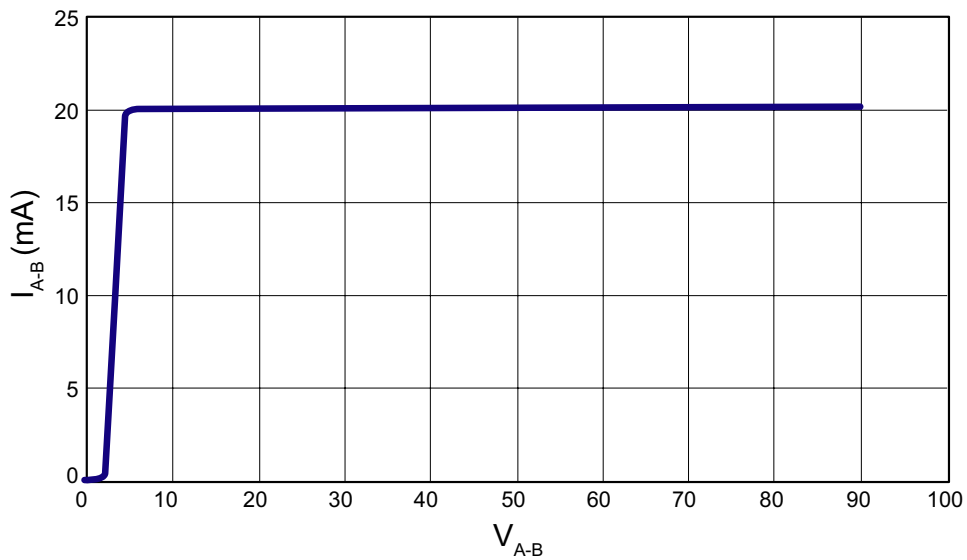

CL2 for Multiple LED Strings

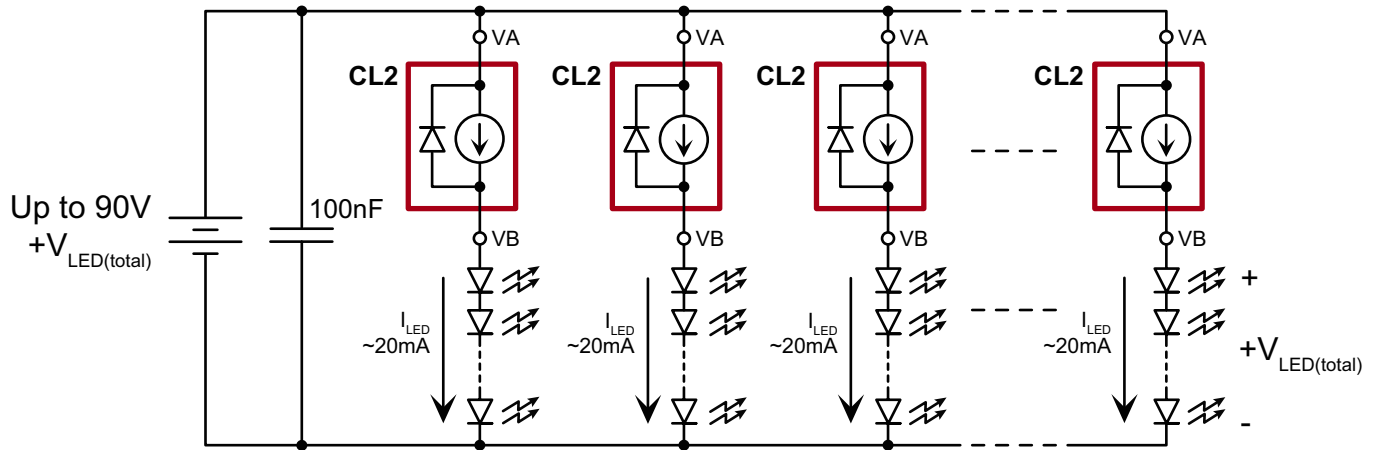

CL2 for Higher Current

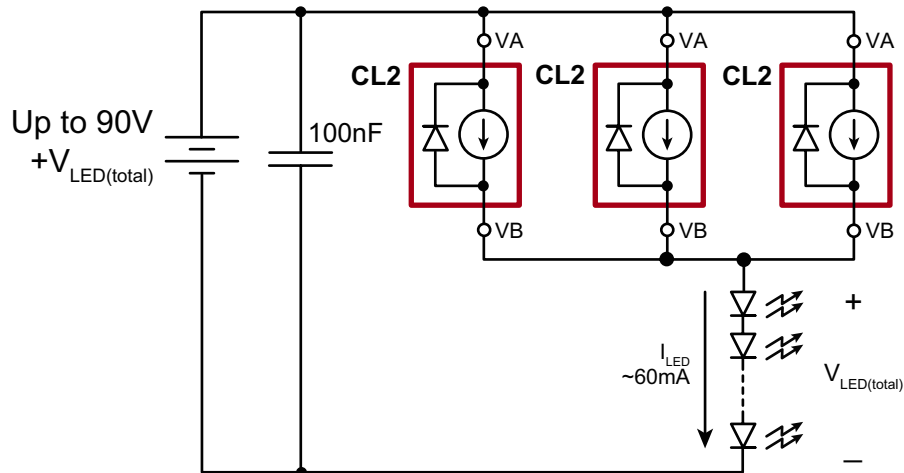

3-Lead TO-252 D-PAK Package Outline (K4)

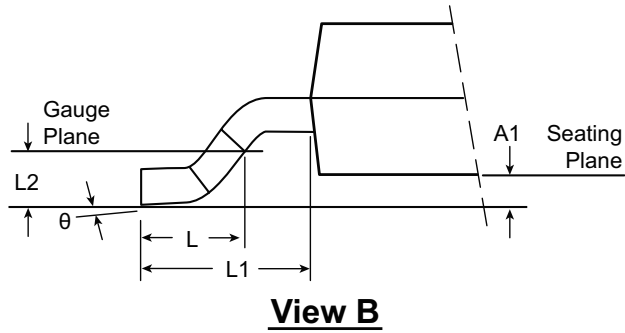
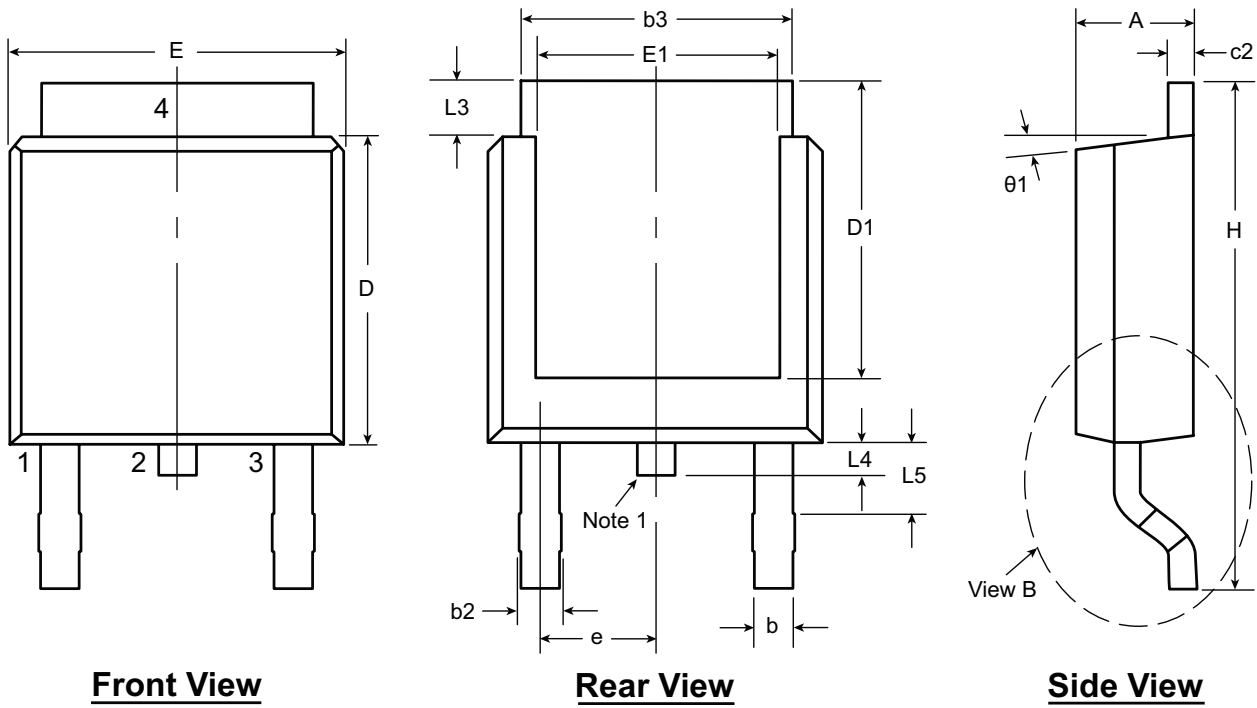

Note:
1. Although 4 terminal locations are shown, only 3 are functional. Lead number 2 was removed.

Symbol	A	A1	b	b2	b3	c2	D	D1	E	E1	e	H	L	L1	L2	L3	L4	L5	θ	θ_1			
Dimension (inches)	MIN	.086	.000*	.025	.030	.195	.018	.235	.205	.250	.170	.090 BSC	.370	.055	.108 REF	.020 BSC	.035	.025*	.045	0°	0°		
	NOM	-	-	-	-	-	-	.240	-	-	-		-	.060			-	-	-	-	-	-	-
	MAX	.094	.005	.035	.045	.215	.035	.245	.217*	.265	.182*		.410	.070			.050	.040	.060	10°	15°		

JEDEC Registration TO-252, Variation AA, Issue E, June 2004.
* This dimension is not specified in the JEDEC drawing.
Drawings not to scale.
Supertex Doc. #: DSPD-3TO252K4, Version E041309.

3-Lead TO-92 Package Outline (N3)

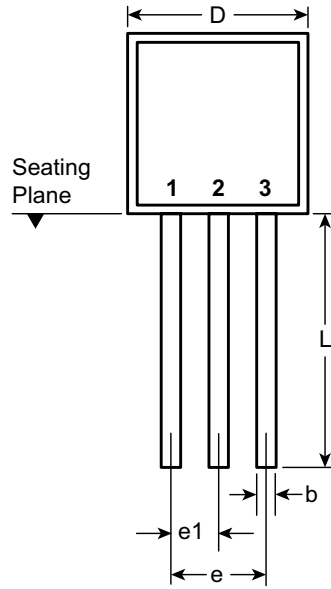

Front View

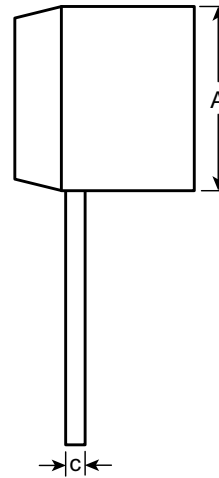

Side View

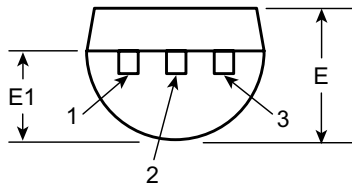

Bottom View

Symbol	A	b	c	D	E	E1	e	e1	L	
Dimensions (inches)	MIN	.170	.014 [†]	.014 [†]	.175	.125	.080	.095	.045	.500
	NOM	-	-	-	-	-	-	-	-	-
	MAX	.210	.022 [†]	.022 [†]	.205	.165	.105	.105	.055	.610*

JEDEC Registration TO-92.

* This dimension is not specified in the JEDEC drawing.

† This dimension differs from the JEDEC drawing.

Drawings not to scale.

Supertex Doc.#: DSPD-3TO92N3, Version E041009.

3-Lead TO-243AA (SOT-89) Package Outline (N8)

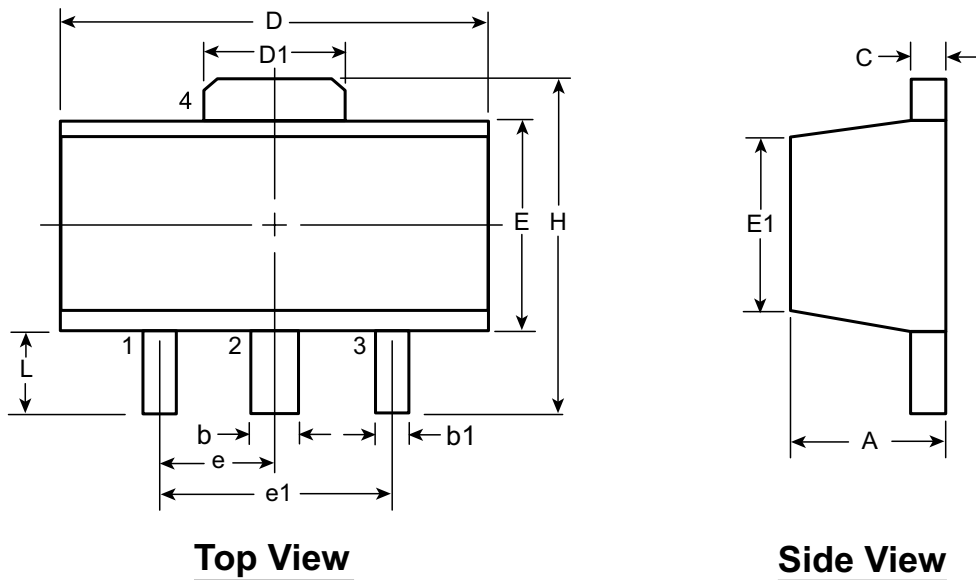

Symbol		A	b	b1	C	D	D1	E	E1	e	e1	H	L		
Dimensions (mm)	MIN	1.40	0.44	0.36	0.35	4.40	1.62	2.29	2.00 [†]	1.50 BSC	3.00 BSC	3.94	0.73 [†]		
	NOM	-	-	-	-	-	-	-	-			-	-	-	-
	MAX	1.60	0.56	0.48	0.44	4.60	1.83	2.60	2.29			-	-	4.25	1.20

JEDEC Registration TO-243, Variation AA, Issue C, July 1986.

[†] This dimension differs from the JEDEC drawing

Drawings not to scale.

Supertex Doc. #: DSPD-3TO243AAN8, Version F111010.

(The package drawings in this data sheet may not reflect the most current specifications. For the latest package outline information go to <http://www.supertex.com/packaging.html>.)

Supertex inc. does not recommend the use of its products in life support applications, and will not knowingly sell them for use in such applications unless it receives an adequate "product liability indemnification insurance agreement." **Supertex inc.** does not assume responsibility for use of devices described, and limits its liability to the replacement of the devices determined defective due to workmanship. No responsibility is assumed for possible omissions and inaccuracies. Circuitry and specifications are subject to change without notice. For the latest product specifications refer to the **Supertex inc.** (website: <http://www.supertex.com>)



Стандарт Электрон Связь

Мы молодая и активно развивающаяся компания в области поставок электронных компонентов. Мы поставляем электронные компоненты отечественного и импортного производства напрямую от производителей и с крупнейших складов мира.

Благодаря сотрудничеству с мировыми поставщиками мы осуществляем комплексные и плановые поставки широчайшего спектра электронных компонентов.

Собственная эффективная логистика и склад в обеспечивает надежную поставку продукции в точно указанные сроки по всей России.

Мы осуществляем техническую поддержку нашим клиентам и предпродажную проверку качества продукции. На все поставляемые продукты мы предоставляем гарантию .

Осуществляем поставки продукции под контролем ВП МО РФ на предприятия военно-промышленного комплекса России , а также работаем в рамках 275 ФЗ с открытием отдельных счетов в уполномоченном банке. Система менеджмента качества компании соответствует требованиям ГОСТ ISO 9001.

Минимальные сроки поставки, гибкие цены, неограниченный ассортимент и индивидуальный подход к клиентам являются основой для выстраивания долгосрочного и эффективного сотрудничества с предприятиями радиоэлектронной промышленности, предприятиями ВПК и научно-исследовательскими институтами России.

С нами вы становитесь еще успешнее!

Наши контакты:

Телефон: +7 812 627 14 35

Электронная почта: sales@st-electron.ru

Адрес: 198099, Санкт-Петербург,
Промышленная ул, дом № 19, литера Н,
помещение 100-Н Офис 331