



MAX2602 Evaluation Kit

Evaluates: MAX2601/MAX2602

General Description

The MAX2602 evaluation kit (EV kit) simplifies the evaluation of the MAX2602 1W RF power transistor for 900MHz band applications. The EV kit demonstrates the MAX2602 in a 3.6V, 836MHz, 1W (30dBm) RF power amplifier for constant-envelope applications.

The EV kit is shipped with a MAX2602, which contains an internal biasing diode. With a simple modification, the MAX2602 EV kit can be used to emulate the MAX2601, which does not have an internal biasing diode.

Features

- ◆ **1W (30dBm) Output Power at 836MHz**
- ◆ **50Ω Inputs and Outputs**
- ◆ **+2.7V to +5.5V Supply Range**
- ◆ **11dB Gain at 836MHz**

Ordering Information

PART	TEMP. RANGE	BOARD TYPE
MAX2602EVKIT-SO	-40°C to +85°C	Surface Mount

Component List

DESIGNATION	QTY	DESCRIPTION
C1, C2	2	2pF surface-mount capacitors
C3	1	10pF surface-mount capacitor
C4	1	12pF surface-mount capacitor
C5-C8, C11, C12	6	1000pF surface-mount capacitors
C9, C11	2	0.1μF surface-mount capacitors
L1	1	100nH surface-mount inductor
L2	1	18.5nH surface-mount spring inductor Coilcraft A05T (Note 1)
R1	1	430Ω surface-mount resistor
R2	1	24Ω surface-mount resistor
R3	1	0Ω resistor
IN, OUT	2	Edge-mount SMA connectors
U1	1	MAX2602ESA (8-pin, thermally enhanced SO)
None	1	MAX2601/MAX2602 data sheet
None	1	Printed circuit board

Note 1: Contact Coilcraft by phone at (800) 322-2645, by fax at (847) 639-1469, or on the World Wide Web at <http://www.coilcraft.com>.

Quick Start

The following section provides instructions for setting up the MAX2602 EV kit as a 1W RF power amplifier.

Test Equipment Required

- RF signal generator capable of at least 20dBm of output power at 836MHz
- Attenuator that can handle at least 30dBm (1W) of RF power (used to protect the test equipment)
- RF spectrum analyzer for use at 836MHz (alternatively, a power meter can be used)
- DC power supply capable of delivering 1A at +2.7V to +5.5V

Connections and Setup

Follow these steps for connecting the EV kit:

- 1) Connect a 50Ω RF signal generator capable of supplying at least 20dBm at 836MHz to the RF input SMA connector ("IN"). Set the generator's initial output to a much lower power (-10dBm, for instance). Keep this generator's RF output off at this time.
- 2) Connect a fixed attenuator that can handle 1W of power to the output SMA connector ("OUT"). This attenuator reduces the power to the test equipment and protects it from overload. Connect this attenuator's output to a spectrum analyzer that is set to display 836MHz. It may be possible to set a reference-level offset on the analyzer to compensate for the attenuator. Consult your spectrum analyzer's manual for details.
- 3) Set the power supply to +3.6V with a 1A current limit. Disable the output. Connect the power supply to the V_C terminal on the EV kit through an ammeter.



MAX2602 Evaluation Kit

- 4) Connect the same power supply through a separate lead to the EV kit's V_B terminal.
- 5) Verify that all the connections are correct to avoid damaging the transistor or your test equipment.
- 6) Turn on the 3.6V supply. Note the supply current with the RF generator off. It should be around 100mA.
- 7) Activate the RF signal generator and slowly increase the generator's output power to 20dBm. At this time, the supply current should be about 500mA, and the output power should be 30dBm.

Detailed Description

Figure 1 is the schematic for the MAX2602 EV kit as shipped. The circuit consists of four blocks: power-supply decoupling, a bias network, and both input and output matching networks. The amplifier built on this board is biased for class AB operation at 1W of output power, and provides high efficiency.

Supply Decoupling Circuitry and Grounding

Capacitors C8 and C10 provide decoupling for V_C . The collector has two separate pins: one for the V_C input (connected through choke L2), and one for the RF output.

The most important contact for the MAX2602 is not on the top of the board; it is the bottom-side emitter contact that is connected to ground. This contact keeps

emitter inductance as low as possible, as excessive emitter inductance can degrade the performance of any RF common-emitter amplifier. The bottom-side contact is also the principal path for heat dissipation, and must be connected to a large ground plane.

Biasing

Capacitors C5, C9, and C11 provide decoupling for the bias supply. The transistor's bias current is set by the internal biasing diode's current. This current is set by the following equation:

$$I_B = \frac{V_B - 0.75V}{R1}$$

The collector current is scaled to the bias current: $I_C = 15I_B$. R3 is used as a jumper. The transistor's base is biased through R2 and L1 (a choke). For more information on the internal biasing diode's operation, refer to the MAX2601/MAX2602 data sheet.

Input Matching Network

The transistor's RF input does not present a 50Ω impedance, so a matching network is required for proper operation in a 50Ω environment. This network consists of capacitor C1 to ground, approximately 1 inch (or 2.5cm) of the 50Ω transmission line (T1), a DC-blocking capacitor (C6), and a shunt capacitor at the transistor base (C4).

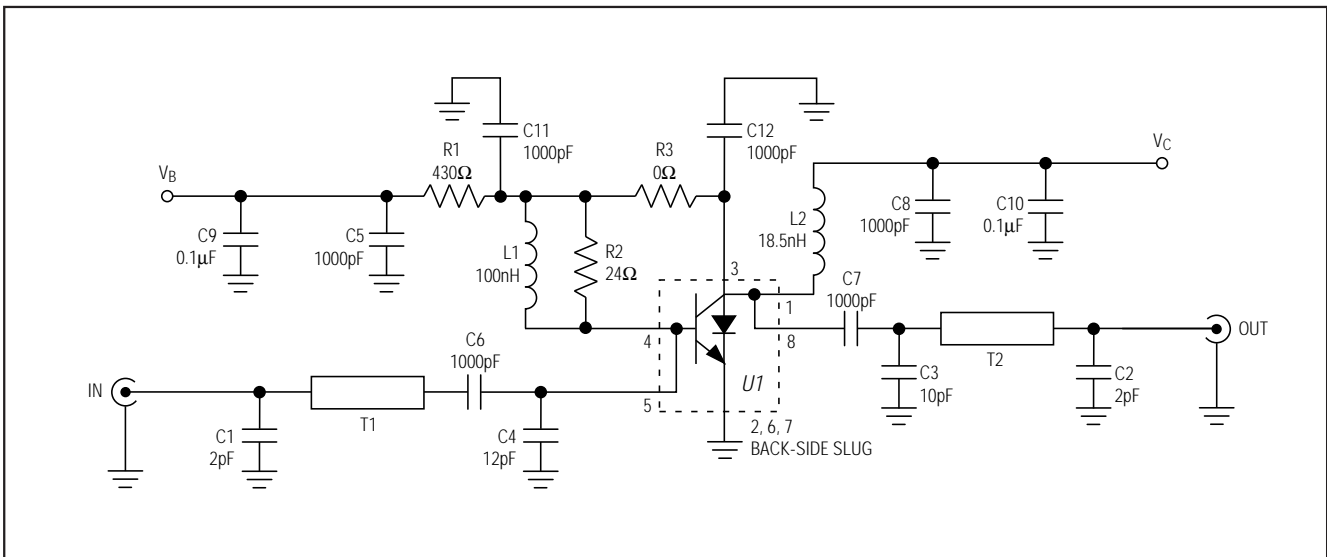

Figure 1. MAX2602 EV Kit Schematic

MAX2602 Evaluation Kit

Evaluates: MAX2601/MAX2602

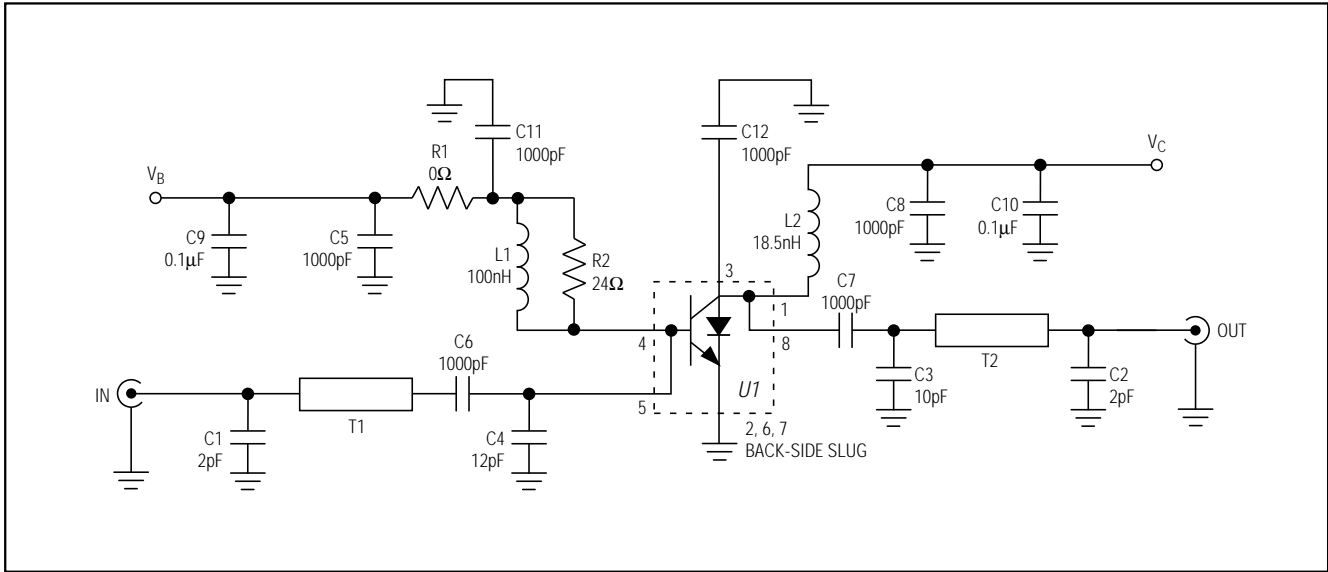

Figure 2. MAX2602 EV Kit Schematic Without the Bias Diode

Output Matching Network

The RF output is taken from pin 8 and is not at 50Ω impedance, so a matching network is required. The matching network consists of a shunt capacitor at the collector (C3), a DC-blocking capacitor (C7), a 50Ω transmission line (T2), and a shunt capacitor (C2).

Evaluating the MAX2602 Without the Biasing Diode

To evaluate the MAX2602 without the biasing diode (functionally equivalent to the MAX2601), the 0Ω resistor (R3) must be removed, and the 430Ω resistor (R1) must be replaced by a 0Ω resistor (a short) (Figure 2). Now an external bias voltage may be connected to the EV kit's V_B input. The biasing diode is no longer connected, so the EV kit will not work without an external biasing voltage. To avoid damage to the MAX2602 in

this mode, be sure to turn the V_C supply on before the V_B supply. When turning the part off, turn the V_B supply off first and then the V_C supply. External bias voltages ranging from 0V to 0.85V are typically used.

Layout Considerations

For best results, use the MAX2602 EV kit as a layout guide. The most critical connection is the emitter-ground contact on the MAX2602's bottom side. On the EV kit, this contact is made through a large (0.1 inch, 2.5mm diameter) plated through-hole in the board, located directly under the part. This contact must be soldered directly to a large ground plane, as it is the principal path for heat dissipation, as well as the low-inductance emitter ground. The MAX2602 EV kit uses its ground plane as the heatsink.

MAX2602 Evaluation Kit

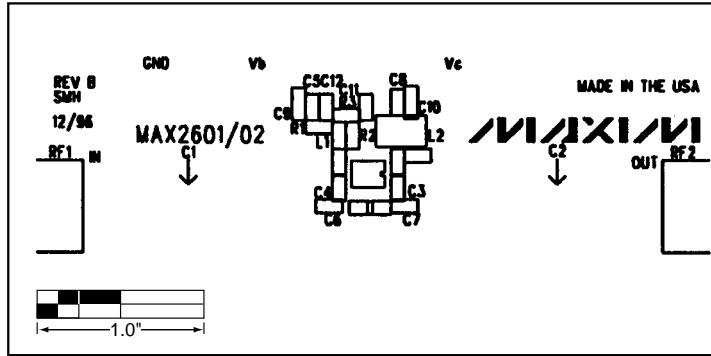

Figure 3. MAX2602 EV Kit Component Placement Guide

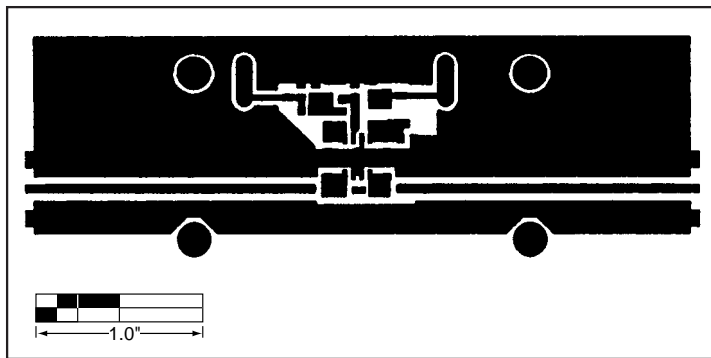

Figure 4. MAX2602 EV Kit PC Board Layout—Component Side

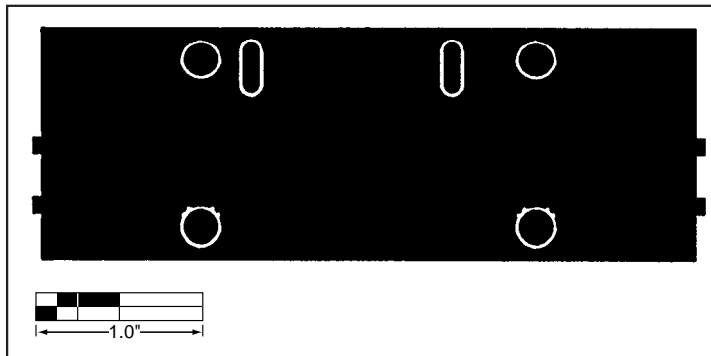

Figure 5. MAX2602 EV Kit PC Board Layout—Solder Side (ground plane and heatsink)

Maxim cannot assume responsibility for use of any circuitry other than circuitry entirely embodied in a Maxim product. No circuit patent licenses are implied. Maxim reserves the right to change the circuitry and specifications without notice at any time.

4 _____ Maxim Integrated Products, 120 San Gabriel Drive, Sunnyvale, CA 94086 408-737-7600



Стандарт Электрон Связь

Мы молодая и активно развивающаяся компания в области поставок электронных компонентов. Мы поставляем электронные компоненты отечественного и импортного производства напрямую от производителей и с крупнейших складов мира.

Благодаря сотрудничеству с мировыми поставщиками мы осуществляем комплексные и плановые поставки широчайшего спектра электронных компонентов.

Собственная эффективная логистика и склад в обеспечивает надежную поставку продукции в точно указанные сроки по всей России.

Мы осуществляем техническую поддержку нашим клиентам и предпродажную проверку качества продукции. На все поставляемые продукты мы предоставляем гарантию .

Осуществляем поставки продукции под контролем ВП МО РФ на предприятия военно-промышленного комплекса России , а также работаем в рамках 275 ФЗ с открытием отдельных счетов в уполномоченном банке. Система менеджмента качества компании соответствует требованиям ГОСТ ISO 9001.

Минимальные сроки поставки, гибкие цены, неограниченный ассортимент и индивидуальный подход к клиентам являются основой для выстраивания долгосрочного и эффективного сотрудничества с предприятиями радиоэлектронной промышленности, предприятиями ВПК и научно-исследовательскими институтами России.

С нами вы становитесь еще успешнее!

Наши контакты:

Телефон: +7 812 627 14 35

Электронная почта: sales@st-electron.ru

Адрес: 198099, Санкт-Петербург,
Промышленная ул, дом № 19, литера Н,
помещение 100-Н Офис 331