



A Maxim Integrated Products Brand

PHY1095-01

1.25Gbps High Sensitivity Transimpedance Amplifier

Features

- -32dBm Sensitivity
- Up to 1.25Gbps (NRZ) data rates
- 60nA rms typical input referred noise
- Automatic gain control
- Flexible bond pad layout and output signal inversion for simple ROSA layout
- Received Signal Strength Indicator output with selectable direction of current flow
- -40 to +95°C operating temperature range

Applications

- GEAPON Optical Network Unit (ONU)
- Gigabit Ethernet

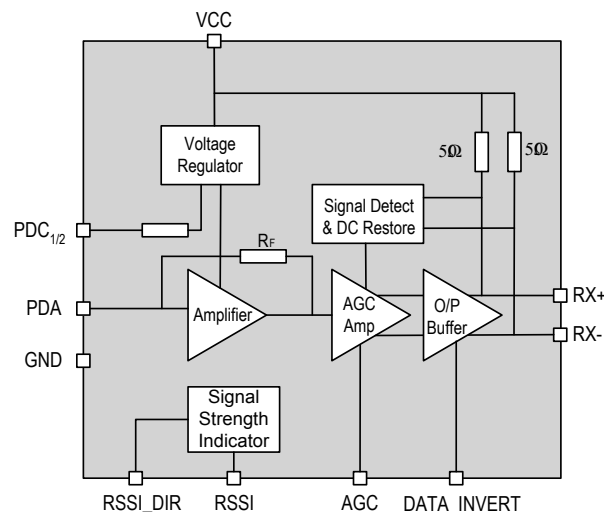

Figure 1: Outline block diagram

Description

The PHY1095 is a transimpedance amplifier designed for use within small form factor fibre optic modules targeted at Gigabit Enabled Passive Optical Network (GEPON) applications.

Working from a 3.3V power supply the PHY1095 integrates a low noise transimpedance amplifier, with a typical differential transimpedance of 60k Ω , an AGC and an output stage.

The RSSI pad can be used to implement a signal strength monitor circuit. This is designed to sink or source a current equal to the photodiode current for ease of interfacing.

Sensitivity of -32dBm can be achieved at 1.25Gbps using a photodiode with 0.5pF capacitance and a responsivity of 0.8A/W at a wavelength of 1490nm.

The PHY1095 is available in die form for mounting on a header to create a ROSA when combined with suitable optics and photo-detector diode.

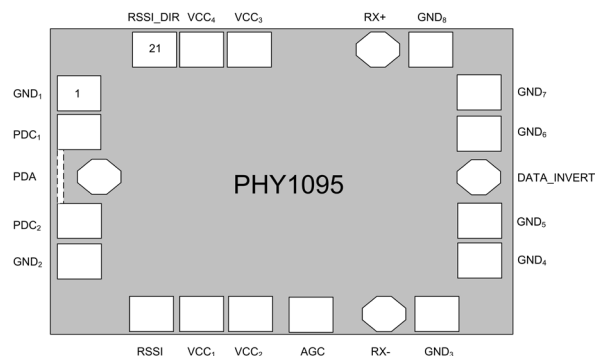

Figure 2: Device pad layout

1 Ordering Information

Part Number	Description	Package
PHY1095-01DS-WR	1.25G High Sensitivity TIA	Bare die in wafer pack
PHY1095-01DS-FR	1.25G High Sensitivity TIA	Film on grip ring

2 Pad Description

Number	Name	Type	Description
1	GND ₁	PWR	Connect to Analog Ground
2	PDC ₁	Analog	Regulated Power supply to Photodiode Cathode
3	PDA	Analog	Connect to Photodiode anode, input to TIA stage
4	PDC ₂	Analog	Regulated Power supply to Photodiode Cathode
5	GND ₂	PWR	Connect to Analog Ground
6	RSSI	Analog Out	Received Signal Strength output. Sinks or sources current equal to PD current
7	VCC ₁	PWR	3.3 Volt Power supply connection
8	VCC ₂	PWR	3.3 Volt Power supply connection
9	RX-	Analog Out	Differential Analog Output pair with RX+
10	GND ₃	GND	Connect to Analog Ground
11	GND ₄	GND	Connect to Analog Ground
12	GND ₅	GND	Connect to Analog Ground
13	DATA_INVERT	Analog Input	Inverts polarity of data output pins RX+ and RX-
14	GND ₆	GND	Connect to Analog Ground
15	GND ₇	GND	Connect to Analog Ground
16	GND ₈	GND	Connect to Analog Ground
17	RX+	Analog Out	Differential Analog Output pair with RX-
18	AGC	Analog	Disables AGC amplifier function when connected to GND
19	VCC ₃	PWR	3.3 Volt Power supply connection
20	VCC ₄	PWR	3.3 Volt Power supply connection
21	RSSI_DIR	Analog Input	Selects whether RSSI output is a current sink or source. Open circuit is a current sink, connect to Ground for current source

3 Device Specifications

3.1 Absolute Maximum Ratings

Exceeding these limits may cause permanent damage. Correct operation under these conditions is not implied. Extended periods of operation under these conditions may affect device reliability.

Parameter	Conditions	Min	Max	Unit
Supply voltage		-0.5	4.0	V
Maximum Voltage on signal pins		-0.5	V _{cc} + 0.5V	V
Device Operating Temperature	Measured on Die		+115	°C
Storage Temperature		-55	150	°C
Die Attach Temperature			400	°C
PDA Input Current ¹	Average input current, VCC > 3.0V, PIN photodiode biased internally from PDC, ER=10dB		3.0	mA
	Ramp time of input current to maximum (0mA to 3mA) from initial optical input	200		µs
ESD Performance	Human Body Model (excluding PDA pin)	2.0		kV
	Human Body Model (PDA pin)	0.5		kV

Notes: ¹ See section 4.1 in case of external V_{pd} biasing of the photodiode

3.2 Recommended Operating Conditions

Parameter	Conditions	Min	Typ	Max	Unit
Supply voltage		3.0	3.3	3.6	V
Current consumption	Including output termination	30	42	55	mA
Ambient Operating temperature		-40		95	°C
Photodiode Capacitance	Photodiode bias voltage 1.8V			1.0	pF

3.3 Parametric Performance

Parameter	Conditions	Min	Typ	Max	Unit
High-speed data input rate	$C_{IN} = 0.5\text{pF}$			1.25	Gbps
Sensitivity Examples	$C_{IN} = 0.5\text{pF}$, Responsivity = 0.8A/W, BER = 10^{-12} ER = 10dB		-31.5		dBm
	$C_{IN} = 0.5\text{pF}$, Responsivity = 0.8A/W, BER = 10^{-10} ER = 10dB		-32.0		dBm
Input referred noise	$C_{IN} = 0.5\text{pF}$, Measured into a 940MHz, 4 th order Bessel filter.		60	90	nA rms
Small Signal Bandwidth (-3dB)	Relative to 100MHz, $C_{IN} = 0.5\text{pF}$	750	860		MHz
Low frequency cut-off	Relative to +100MHz		25		kHz
Gain Variation with Frequency	1MHz to 630MHz			± 2	dB
Differential Output Swing ¹	Input current > 8 μA pp 100 Ω differential load, 1.25Gbps	320	400	480	mVp-p
Parameter	Conditions	Min	Typ	Max	Unit
Transimpedance (differential)	Input current < 8 μA p-p	50k	60k	70k	Ω
Deterministic Jitter	K28.5 Pattern		25	50	mUIp-p
Overshoot	2 ⁷ -1PRBS (wrt to average 0/1 level)			± 15	%
Undershoot	2 ⁷ -1PRBS (wrt average 0/1 level)			± 15	%
Input Overload, a.c.	DJ within spec	1.5			mApp
Input Overload d.c.	DJ within spec	1.0			mA
AGC settling time				50	μs
Output resistance	Differential RX+ to RX-	80	100	120	Ω
Photodiode Cathode Voltage	0.3 μA photodiode current	2.5	2.6	2.7	V
Photodiode Anode Voltage			0.8	1.0	V
RSSI Current Accuracy	Measured relative to photodiode current			± 20	%
RSSI Compliance Voltage	Source mode, $I_{IN}=0.5\text{mA}$	0		1.1	V
	Sink mode, $I_{IN}=0.5\text{mA}$	0.7		VDD-0.8	V
Power Supply Rejection Ratio	100kHz - 4MHz	30	40		dB

Notes: ¹ Expected load is 2 x 50 ohms

4 Device Description

The PHY1095 implements a complete analog front end, converting the photo-detector current, into a differential analog voltage signal.

The PHY1095 also provides a filtered bias current to the photo-detector to increase the level of component integration as well as the signal processing functions.

4.1 Photodiode Connection

The recommended method to connect a PIN photodiode to PHY1095 is using the internal voltage reference to bias the Photodiode as shown in figure 3. The internal reference supplies a low noise output with high power supply rejection to 4GHz.

Connection of a PIN photodiode to the PDA input with an external Vpd bias supply can produce inconsistent sensitivity and bandwidth operation. The maximum damage level for the PDA input is reduced to <1mA when PDA is connected in this way.

The voltage across the photodiode is equal to the power supply voltage, Vpdc minus the input bias voltage of the input of the PHY1095, equal to Vpda. The anode voltage, Vpda is sensitive to temperature and has a typical value of 0.8V.

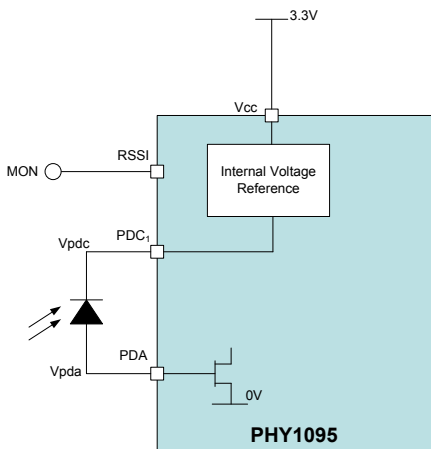

Figure 3 – Photodiode biased by internal voltage regulator

4.2 DC Cancellation

The removal of the direct current component of the input signal is necessary to reduce the pulse width distortion for signals with a 50% mark density.

The DC cancellation block provides low frequency feedback using an internally compensated amplifier, removing the need for external compensation capacitors.

4.3 Transimpedance Amplifier (TIA)

The transimpedance (current to voltage) stage is a very low noise amplifier with a feedback resistor to set the gain. This stage features automatic gain control, where the transimpedance depends on the output signal level. This ensures that the output does not overload the subsequent stage in the signal path.

An internal voltage regulator is used to power the front-end transimpedance amplifier in order to improve the rejection of power supply noise.

4.4 Output Gain Stage

The output gain stage features a voltage amplifier, a single ended to differential converter and a supply referenced differential output buffer.

The PHY1095 has a 50Ω single ended output impedance, which is suitable for the majority of applications. For optimum supply-noise rejection, the PHY1095 should be terminated differentially.

4.5 Output Data Polarity

The data polarity pin has an internal 8kΩ pull-up resistor. In normal non-inverting operation, where there is no external connection, the pin pulls to VDD. In this mode an optical '1' gives maximum input current and a voltage '1' on the positive output pin Rx+. Connection of the pad to ground selects an inverted sense output.

4.6 Received Signal Strength Indication (RSSI)

The PHY1095 provides a RSSI output which can be used to measure the strength of the received optical signal. The photodiode current is proportional to the received optical power. The PHY1095 generates an output current which is a mirror of the photodiode current. The RSSI output is either a current sink or a current source.

The direction of current flow is selected by using the RSSI_DIR bond. Leaving this bond pad unconnected selects a current sink, connecting this bond pad to ground selects a current source.

An alternative method of measuring the received signal power is by using the received Optical Modulation Amplitude (OMA). This method is provided by the PHY1078 integrated burst mode laser driver and post amplifier device.

5 Typical Application

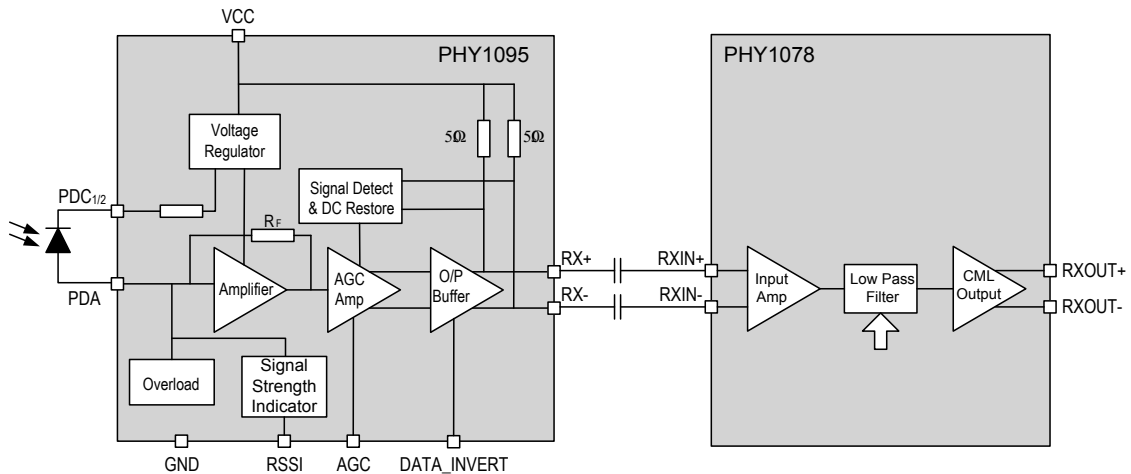

Figure 4 - Typical Application: GEAPON ONU Receiver path

Figure 4 shows a typical application for the PHY1095. In this application the output of the PHY1095 is connected to the Phyworks PHY1078 PON Laser Driver and Post Amplifier circuit to form the receive path for a fibre optic module.

The PHY1078 provides the receive signal monitoring functions such as loss of signal and converts the input data into a variety of electrical formats.

5.1 Layout and Bonding

In order to achieve the best performance it is necessary to minimise noise pickup and to reduce the effects of parasitic components.

Noise is picked up through the signal paths or through the power supply. Noise at the input of the TIA will be amplified and mixed with the wanted signal. This can be a result of noise pickup in the other components connected to the TIA input, such as the photodiode, the capacitors and the bond wires.

Noise picked up in the signal path can be reduced by keeping bond wires short and by making sure the output and input bond wires are not close and are orthogonal to each other,

Power supply noise will be present as a result of the power supply design, the quality of decoupling precautions and pickup in the bond wires.

To effectively de-couple supply rail noise to ground a capacitor may be placed inside the ROSA. This should be placed as close as possible to the VCC pin on the TIA. This reduces the effect of the bond wire inductance.

The high PSRR performance of PHY1095 enables the decoupling capacitor to be omitted and fewer ground bonds used without degradation to sensitivity. See Figure 6 and 7 for this low cost bonding option. Decoupling for supply and RSSI is recommended to be used on the optical host board.

Noise on the power supply can also be a result of coupling between the TIA output and the power supply. This coupling takes place between the output bond wires and the power supply bond wires. As a result these must also be kept as short as possible and be routed orthogonally to each other.

The PHY1095 provides alternative bonding options through the replication of some device inputs and outputs, allowing a variety of ROSA pin outs to be realised without compromising performance.

6 Mechanical Specifications

6.1 TO-Can Connections

Top-view: looking into the CD header. The diagrams below show an internal power supply decoupling capacitor and illustrate the optimum bondwire lengths and orientation. The value of the supply de-coupling capacitor should be 250 – 500 pF.

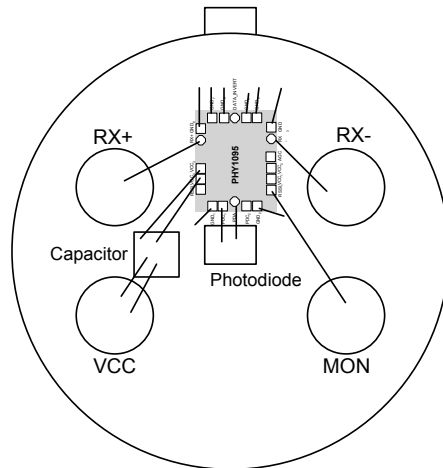

Figure 5 - 5 pin ROSA with decoupling

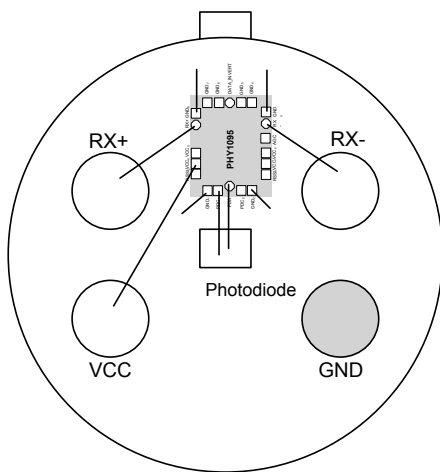

Figure 6 – Low Cost 4 pin ROSA

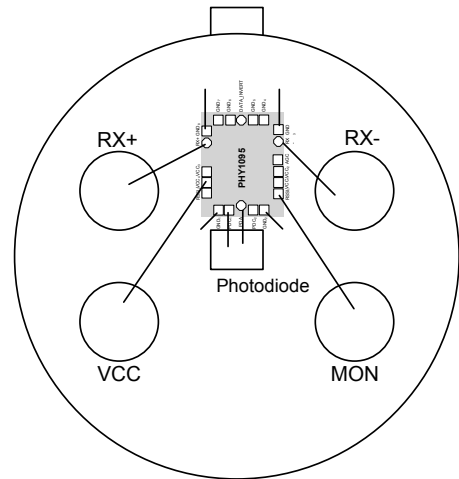

Figure 7 – Low Cost 5 pin ROSA

7 Pad Positions and Sizes

Die Size: 1100 μ m x 900 μ m

Thickness: 290 μ m +/- 10 μ m

Pad Opening: 80 μ m x 80 μ m measured between parallel sides

Number	Name	Pad centres	
		X	Y
1	GND ₁	-439.5	221.5
2	PDC ₁	-439.5	113
3	PDA	-412.5	0
4	PDC ₂	-439.5	-113
5	GND ₂	-439.5	-221.5
6	RSSI	-320.095	-339.5
7	VCC ₁	-219.5	-339.5
8	VCC ₂	-121.5	-339.5
9	AGC	55.09	-339.5
10	RX-	222.1	-339.5
11	GND ₃	321.5	-339.5
12	GND ₄	439.5	-221.5
13	GND ₅	439.5	-123.5
14	DATA_INVERT	439.5	0
15	GND ₆	439.5	123.5
16	GND ₇	439.5	221.5
17	GND ₈	321.5	339.5
18	RX+	222.1	339.5
19	VCC ₃	-121.5	339.5
20	VCC ₄	-219.5	339.5
21	RSSI_DIR	-320.095	339.5

Table 1: PHY1095 pad coordinates

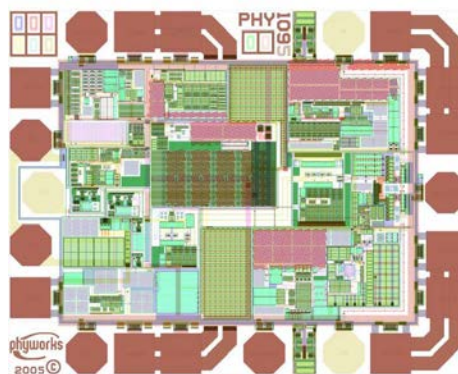

Figure 8: PHY1095 Die image

8 Contact Information

For technical support, contact Maxim at www.maxim-ic.com/support.

Disclaimer

This datasheet contains preliminary information and is subject to change.

This document does not transfer or license any intellectual property rights to the user. It does not imply any commitment to produce the device described and is intended as a proposal for a new device.

Phyworks Ltd assumes no liability or warranty for infringement of patent, copyright or other intellectual property rights through the use of this product.

Phyworks Ltd assumes no liability for fitness for particular use or claims arising from sale or use of its products.

Phyworks Ltd products are not intended for use in life critical or sustaining applications.



Стандарт Электрон Связь

Мы молодая и активно развивающаяся компания в области поставок электронных компонентов. Мы поставляем электронные компоненты отечественного и импортного производства напрямую от производителей и с крупнейших складов мира.

Благодаря сотрудничеству с мировыми поставщиками мы осуществляем комплексные и плановые поставки широчайшего спектра электронных компонентов.

Собственная эффективная логистика и склад в обеспечивает надежную поставку продукции в точно указанные сроки по всей России.

Мы осуществляем техническую поддержку нашим клиентам и предпродажную проверку качества продукции. На все поставляемые продукты мы предоставляем гарантию .

Осуществляем поставки продукции под контролем ВП МО РФ на предприятия военно-промышленного комплекса России , а также работаем в рамках 275 ФЗ с открытием отдельных счетов в уполномоченном банке. Система менеджмента качества компании соответствует требованиям ГОСТ ISO 9001.

Минимальные сроки поставки, гибкие цены, неограниченный ассортимент и индивидуальный подход к клиентам являются основой для выстраивания долгосрочного и эффективного сотрудничества с предприятиями радиоэлектронной промышленности, предприятиями ВПК и научно-исследовательскими институтами России.

С нами вы становитесь еще успешнее!

Наши контакты:

Телефон: +7 812 627 14 35

Электронная почта: sales@st-electron.ru

Адрес: 198099, Санкт-Петербург,
Промышленная ул, дом № 19, литера Н,
помещение 100-Н Офис 331