

Multiple Switch Detection Interface with Suppressed Wake-up and 32 mA Wetting Current

The 33975 Multiple Switch Detection Interface with Suppressed Wake-up is designed to detect the closing and opening of up to 22 switch contacts. The switch status, either open or closed, is transferred to the microprocessor unit (MCU) through a serial peripheral interface (SPI). The device also features a 22-to-1 analog multiplexer for reading inputs as analog.

The 33975 device has two modes of operation, Normal and Sleep. Normal mode allows programming of the device and supplies switch contacts with pull-up or pull-down current as it monitors the switch change of state. The Sleep mode provides low quiescent current, which makes the 33975 ideal for automotive and industrial products requiring low sleep state currents.

Improvements are a programmable interrupt timer for Sleep mode that can be disabled, switch detection currents of 32 mA and 4.0 mA for switch-to-ground inputs, and an interrupt bit that can be reset. This device is powered using SMARTMOS technology.

Features

- Designed to operate from $5.5\text{ V} \leq V_{PWR} \leq 28\text{ V}$
- Switch input voltage: (33975: -14 to 38 V) (33975A: -14 to 40 V)
- Interfaces to microprocessor using 3.3 V/5.0 V SPI protocol
- Selectable wake-up on change of state
- 14 switch-to-ground inputs
- 8 programmable inputs (switches to battery or ground)
- Selectable wetting current (32 mA or 4.0 mA for switch-to-ground inputs)
- Sleep State current V_{PWR} 100 μA , V_{DD} 20 μA

**33975
33975A**

**MULTIPLE SWITCH
DETECTION INTERFACE WITH
SUPPRESSED WAKE-UP**



Applications

- Automotive systems
- Industrial control systems
- Process control systems
- Security systems
- Systems requiring switch status verification for safety, operation, or process control purposes

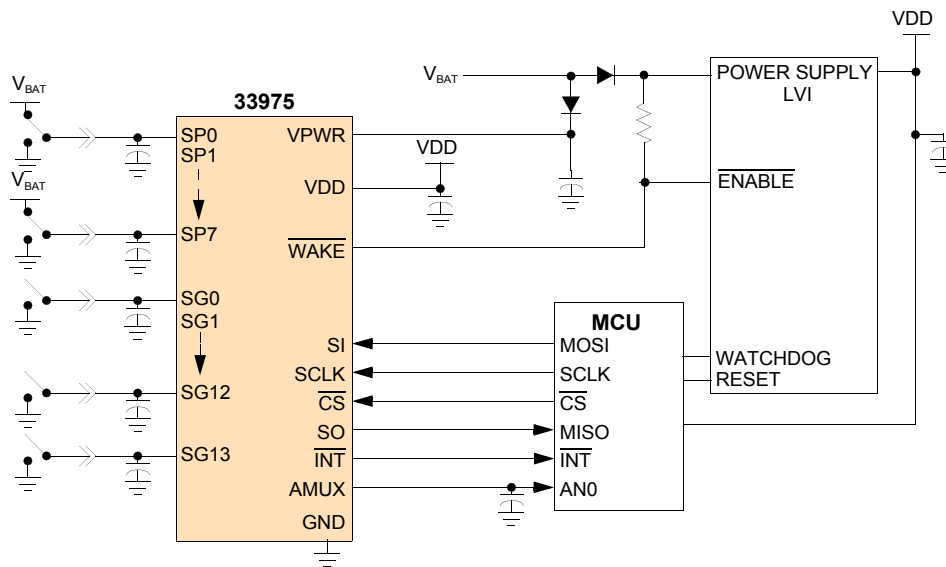

Figure 1. 33975 Simplified Application Diagram

1 Orderable Parts

Table 1. Orderable Part Variations

Part Number	Temperature (T _A)	Package	Switch Input Voltage Range	Reference Location
MC33975TEK/R2	-40 to 125 °C	32 SOICW-EP	-14 to 38 V _{DC}	5
MC33975ATEK/R2			-14 to 40 V _{DC}	5

INTERNAL BLOCK DIAGRAM

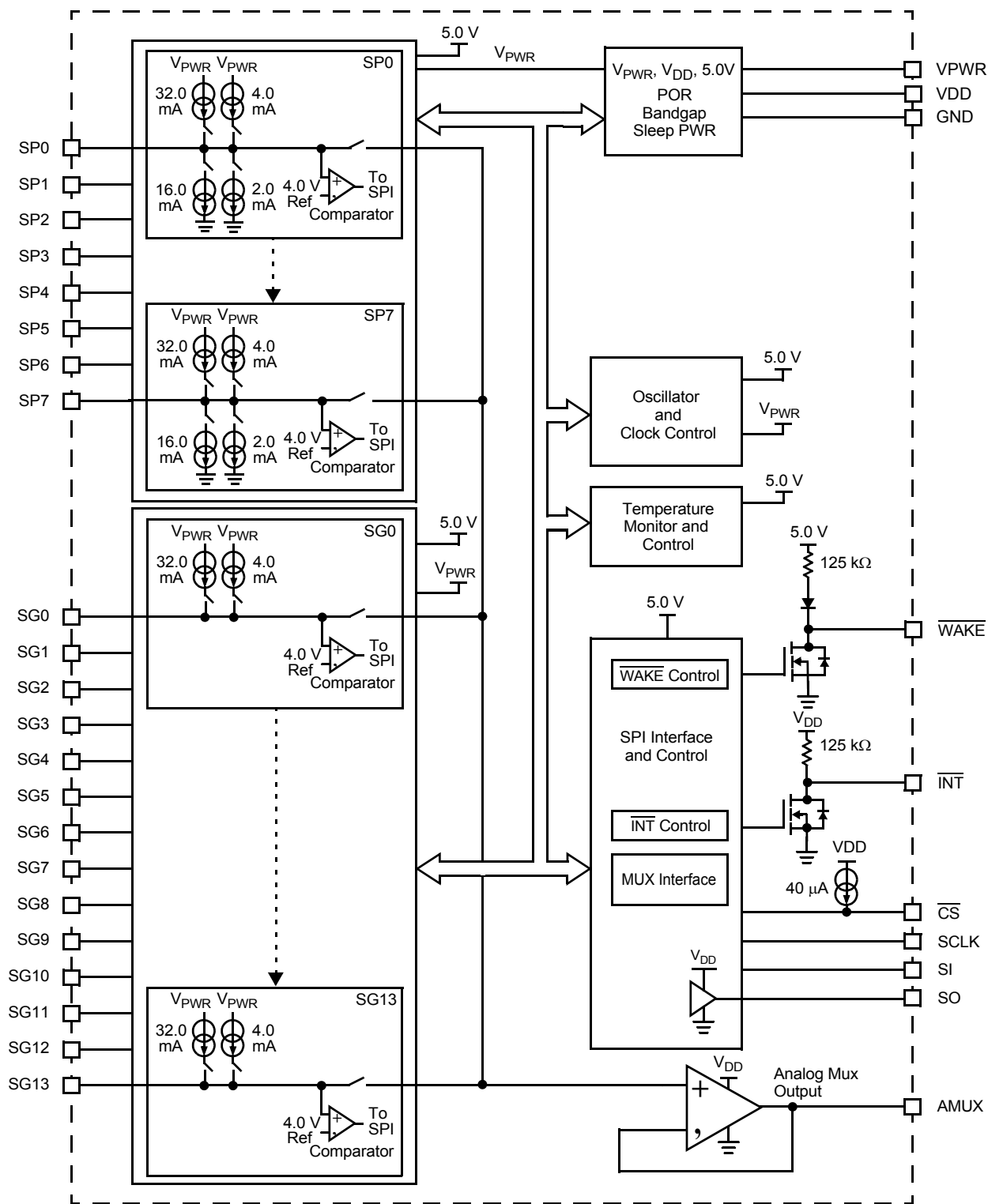

Figure 2. 33975 Simplified Internal Block Diagram

PIN CONNECTIONS

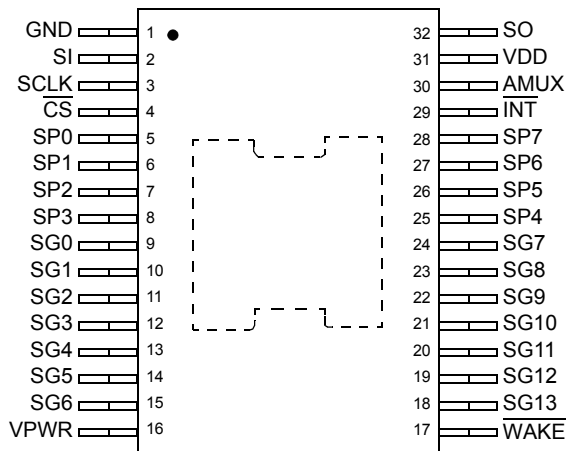

Figure 3. 33975 Pin Connections

Table 2. Pin Definitions

A functional description of each Pin can be found in the Functional Pin Description section on page [12](#).

Pin	Pin Name	Formal Name	Description
1	GND	Ground	Ground for logic, analog, and switch-to-battery inputs
2	SI	SPI Slave In	SPI control data input pin from MCU to 33975
3	SCLK	Serial Clock	SPI control clock input pin
4	\overline{CS}	Chip Select	SPI control chip select input pin from MCU to 33975. Logic [0] allows data to be transferred in
5–8 25–28	SPn	Programmable Switches 0–3 Programmable Switches 4–7	Programmable switch-to-battery or switch-to-ground input pins
9–15, 18–24	SGn	Switch-to-Ground Inputs 0–6 Switch-to-Ground Inputs 13–7	Switch-to-ground input pins
16	VPWR	Battery Input	Battery supply input pin. This pin requires external reverse battery protection.
17	\overline{WAKE}	Wake-up	Open drain wake-up output is designed to control a power supply enable pin
29	\overline{INT}	Interrupt	Open-drain output to MCU is used to indicate input switch change of state
30	AMUX	Analog Multiplex Output	Analog multiplex output
31	VDD	Voltage Drain Supply	3.3/5.0 V supply sets SPI communication level for the SO driver
32	SO	SPI Slave Out	Provides digital data from 33975 to the MCU

ELECTRICAL CHARACTERISTICS

MAXIMUM RATINGS

Table 3. Maximum Ratings

All voltages are with respect to ground unless otherwise noted. Exceeding these limits may cause malfunction or permanent damage to the device.

Rating	Symbol	Value	Unit
ELECTRICAL RATINGS			
VDD Supply Voltage	–	-0.3 to 7.0	V _{DC}
$\overline{\text{CS}}$, SI, SO, SCLK, $\overline{\text{INT}}$, AMUX	–	-0.3 to 7.0	V _{DC}
$\overline{\text{WAKE}}$	–	-0.3 to 40	V _{DC}
VPWR Supply Voltage	–	-0.3 to 50	V _{DC}
VPWR Supply Voltage at -40 °C	–	-0.3 to 45	V _{DC}
Switch Input Voltage Range	–		V _{DC}
33975		-14 to 38	
33975A		-14 to 40	
Frequency of SPI Operation (V _{DD} = 5.0 V)	–	6.0	MHz
ESD Voltage ⁽¹⁾	V _{ESD}		V
Human Body Model ⁽²⁾		±2000	
Applies to all non-input Pins		±2000	
Machine Model		±200	
Charge Device Model			
Corner Pins		750	
Interior Pins		500	
THERMAL RATINGS			
Operating Temperature			°C
Ambient	T _A	-40 to 125	
Junction	T _J	-40 to 150	
Case	T _C	-40 to 125	
Storage Temperature	T _{STG}	-55 to 150	°C
Power Dissipation ⁽³⁾	P _D	1.7	W

Notes

- ESD testing is performed in accordance with the Human Body Model (C_{ZAP} = 100 pF, R_{ZAP} = 1500 Ω), the Machine Model (C_{ZAP} = 200 pF, R_{ZAP} = 0 Ω), and the Charge Device Model.
- All Programmable Switches (SP) and Switch-to-Ground (SG) input pins when tested individually.
- Maximum power dissipation at T_J = 150 °C junction temperature with no heatsink used.
- Thermal resistance between the die and the exposed die pad.

Table 3. Maximum Ratings

All voltages are with respect to ground unless otherwise noted. Exceeding these limits may cause malfunction or permanent damage to the device.

Rating	Symbol	Value	Unit
ELECTRICAL RATINGS			
Thermal Resistance			
Junction to Ambient	$R_{\theta JA}$	71	$^{\circ}C/W$
Between the die and the exposed die pad ⁽⁴⁾	$R_{\theta JC}$	1.2	
Peak Package Reflow Temperature During Reflow ^{(5), (6)}	T_{PPRT}	Note 6	$^{\circ}C$

Notes

- Pin soldering temperature limit is for 10 seconds maximum duration. Not designed for immersion soldering. Exceeding these limits may cause malfunction or permanent damage to the device.
- Freescale's Package Reflow capability meets Pb-free requirements for JEDEC standard J-STD-020C. For Peak Package Reflow Temperature and Moisture Sensitivity Levels (MSL), Go to www.freescale.com, search by part number [e.g. remove prefixes/suffixes and enter the core ID to view all orderable parts. (i.e. MC33xxx enter 33xxx), and review parametrics.

STATIC ELECTRICAL CHARACTERISTICS

Table 4. Static Electrical Characteristics

Characteristics noted under conditions of $3.0\text{ V} \leq V_{DD} \leq 5.5\text{ V}$, $8.0\text{ V} \leq V_{PWR} \leq 28\text{ V}$, $-40\text{ }^\circ\text{C} \leq T_C \leq 125\text{ }^\circ\text{C}$, unless otherwise noted. Where applicable, typical values reflect the parameter's approximate average value with $V_{PWR} = 13\text{ V}$, $T_A = 25\text{ }^\circ\text{C}$.

Characteristic	Symbol	Min	Typ	Max	Unit
POWER INPUT					
Supply Voltage					V
Supply Voltage Range Quasi-functional ⁽⁷⁾	$V_{PWR(QF)}$	5.5	–	8.0	
Fully Operational	$V_{PWR(FO)}$	8.0	–	28	
Supply Voltage Range Quasi-functional ⁽⁸⁾	$V_{PWR(QF)}$	28	–	38/40	
Supply Voltage					V
VPWR Supply Voltage Power On Reset	$V_{PWR(POR)}$	4.2	4.6	5.0	
Supply Current					mA
All Switches Open, Normal Mode, Tri-state Disabled	$I_{PWR(ON)}$	–	4.0	8.0	
Sleep State Supply Current					μA
Scan Timer = 64 ms, Switches Open	$I_{PWR(SS)}$	40	70	100	
Logic Supply Voltage	V_{DD}	3.0	–	5.5	V
Logic Supply Current					mA
All Switches Open, Normal Mode	I_{DD}	–	0.25	0.5	
Sleep State Logic Supply Current					μA
Scan Timer = 64 ms, Switches Open	$I_{DD(SS)}$	–	10	20	
SWITCH INPUT					
Pulse Wetting Current Switch-to-Battery (Current Sink)					mA
$5.5\text{ V} \leq V_{PWR} \leq 28\text{ V}$	I_{PULSE}	12	15	18	
Pulse Wetting Current Switch-to-Ground (Current Source)					mA
$5.5\text{ V} \leq V_{PWR} \leq 8.0\text{ V}$	I_{PULSE}	7.0	9.0	–	
$8.0\text{ V} \leq V_{PWR} \leq 28\text{ V}$		24	32	36	
Sustain Current Switch-to-Battery Input (Current Sink)					mA
$5.5\text{ V} \leq V_{PWR} \leq 28\text{ V}$	$I_{SUSTAIN}$	1.8	2.1	2.4	
Sustain Current Switch-to-Ground Input (Current Source)					mA
$5.5\text{ V} \leq V_{PWR} \leq 8.0\text{ V}$	$I_{SUSTAIN}$	0.5	1.0	–	
$8.0\text{ V} \leq V_{PWR} \leq 28\text{ V}$		3.6	4.0	4.4	
Sustain Current Matching Between Channels on Switch-to-Ground Inputs					%
	$\frac{I_{SUS(MAX)} - I_{SUS(MIN)}}{I_{SUS(MIN)}} \times 100$	–	2.0	5.0	

Notes

- Device operational. Wetting and sustain currents are reduced. Operating the analog multiplexer below 8.0 V is not recommended.
- Thermal considerations must be taken when operating the device above 28 V.

Table 4. Static Electrical Characteristics (continued)

Characteristics noted under conditions of $3.0\text{ V} \leq V_{DD} \leq 5.5\text{ V}$, $8.0\text{ V} \leq V_{PV}$ noted. Where applicable, typical values reflect the parameter's approximate

Table 4. Static Electrical Characteristics (continued)

Characteristics noted under conditions of $3.0\text{ V} \leq V_{DD} \leq 5.5\text{ V}$, $8.0\text{ V} \leq V_{PV}$ noted. Where applicable, typical values reflect the parameter's approximate

Characteristic	Characteristic				
SWITCH INPUT (CONTINUED)		DIGITAL INTERFACE			
Input Offset Current when Selected as Analog	I_{OFFSET}	-2.0	1.4	2.0	μA
Input Offset Voltage when Selected as Analog $V_{(\text{SP\&SGINPUTS})}$ to AMUX output	V_{OFFSET}	-10	2.5	10	mV
Analog Operational Amplifier Output Voltage Sink $250\ \mu\text{A}$	V_{OL}	-	10	30	mV
Analog Operational Amplifier Output Voltage Source $250\ \mu\text{A}$	V_{OH}	$V_{DD} - 0.1$	-	-	V
Switch Detection Threshold	V_{TH}	3.70	4.0	4.3	V
Temperature Monitor ^{(9), (10)}	T_{LIM}	155	-	185	$^{\circ}\text{C}$
Temperature Monitor Hysteresis ⁽¹⁰⁾	$T_{\text{LIM(HYS)}}$	5.0	10	15	$^{\circ}\text{C}$

Notes

9. Thermal shutdown of 16mA and 32mA pull-up and pull-down current sources only. 4.0mA and 2.0mA current source/sink and all other functions remain active.
10. This parameter is guaranteed by design; however it is not production tested.

Table 4. Static Electrical Characteristics (continued)

Characteristics noted under conditions of $3.0\text{ V} \leq V_{DD} \leq 5.5\text{ V}$, $8.0\text{ V} \leq V_{PWR} \leq 28\text{ V}$, $-40\text{ }^\circ\text{C} \leq T_C \leq 125\text{ }^\circ\text{C}$, unless otherwise noted. Where applicable, typical values reflect the parameter's approximate average value with $V_{PWR} = 13\text{ V}$, $T_A = 25\text{ }^\circ\text{C}$.

Characteristic	Symbol	Min	Typ	Max	Unit
Input Logic High Voltage Thresholds ⁽¹¹⁾	V_{IH}	$0.7 \times V_{DD}$	–	$V_{DD} + 0.3$	V
Input Logic Low Voltage Thresholds ⁽¹¹⁾	V_{IL}	$\text{GND} - 0.3$	–	$0.2 \times V_{DD}$	V
SCLK, SI, Tri-state SO Input Current 0.0 V to V_{DD}	$I_{SCLK}, I_{SI},$ $I_{SO(TRI)}$	-10	–	10	μA
$\overline{\text{CS}}$ Input Current $\overline{\text{CS}} = V_{DD}$	$I_{\overline{\text{CS}}}$	-10	–	10	μA
$\overline{\text{CS}}$ Pull-up Current $\overline{\text{CS}} = 0.0\text{ V}$	$I_{\overline{\text{CS}}}$	30	–	100	μA
SO High State Output Voltage $I_{SO(HIGH)} = -200\text{ }\mu\text{A}$	$V_{SO(HIGH)}$	$V_{DD} - 0.8$	–	VDD	V
SO Low State Output Voltage $I_{SO(HIGH)} = 1.6\text{ mA}$	$V_{SO(LOW)}$	–	–	0.4	V
Input Capacitance on SCLK, SI, Tri-state SO ⁽¹²⁾	C_{IN}	–	–	20	pF
$\overline{\text{INT}}$ Internal Pull-up Current	–	15	40	100	μA
$\overline{\text{INT}}$ Voltage $\overline{\text{INT}} = \text{Open Circuit}$	$V_{\overline{\text{INT}}(HIGH)}$	$V_{DD} - 0.5$	–	VDD	V
$\overline{\text{INT}}$ Voltage $I_{\overline{\text{INT}}} = 1.0\text{ mA}$	$V_{\overline{\text{INT}}(LOW)}$	–	0.2	0.4	V
$\overline{\text{WAKE}}$ Internal Pull-Up current	$I_{\overline{\text{WAKE}}(PU)}$	20	40	100	μA
$\overline{\text{WAKE}}$ Voltage $\overline{\text{WAKE}} = \text{Open Circuit}$	$V_{\overline{\text{WAKE}}(HIGH)}$	4.0	4.3	5.3	V
$\overline{\text{WAKE}}$ Voltage $I_{\overline{\text{WAKE}}} = 1.0\text{ mA}$	$V_{\overline{\text{WAKE}}(LOW)}$	–	0.2	0.4	V
$\overline{\text{WAKE}}$ Voltage ⁽¹²⁾ Maximum Voltage Applied to $\overline{\text{WAKE}}$ Through External Pull-up	$V_{\overline{\text{WAKE}}(MAX)}$	–	–	40	V

Notes

11. Upper and lower logic threshold voltage levels apply to SI, $\overline{\text{CS}}$, and SCLK.
12. This parameter is guaranteed by design however, is not production tested.

DYNAMIC ELECTRICAL CHARACTERISTICS

Table 5. Dynamic Electrical Characteristics

Characteristics noted under conditions of $3.0\text{ V} \leq V_{DD} \leq 5.5\text{ V}$, $8.0\text{ V} \leq V_{PWR} \leq 28\text{ V}$, $-40\text{ }^\circ\text{C} \leq T_C \leq 125\text{ }^\circ\text{C}$, unless otherwise noted. Where applicable, typical values reflect the parameter's approximate average value with $V_{PWR} = 13\text{ V}$, $T_A = 25\text{ }^\circ\text{C}$.

Characteristic	Symbol	Min	Typ	Max	Unit
----------------	--------	-----	-----	-----	------

SWITCH INPUT

Table 5. Dynamic Electrical Characteristics

Characteristics noted under conditions of $3.0V \leq VDD \leq 5.5V$, $8.0V \leq V_{PWR} \leq 28V$, $-40^{\circ}C \leq T_C \leq 125^{\circ}C$, unless otherwise noted. Where applicable, typical values reflect the parameter's approximate average value with $V_{PWR} = 13V$, $T_A = 25^{\circ}C$.

Characteristic	Symbol	Min	Typ	Max	Unit
Pulse Wetting Current Time	$t_{PULSE(ON)}$	15	16	22	ms
Interrupt Delay Time Normal Mode	$t_{INT-DLY}$	–	5.0	16	μs
Sleep Mode Switch Scan Time	t_{SCAN}	100	200	300	μs
Calibrated Scan Timer Accuracy Sleep Mode	$t_{SCAN\ TIMER}$	–	–	10	%
Calibrated Interrupt Timer Accuracy Sleep Mode	$t_{INT\ TIMER}$	–	–	10	%

DIGITAL INTERFACE TIMING⁽¹³⁾

Required Low State Duration on VPWR for Reset ⁽¹⁴⁾ $V_{PWR} \leq 0.2V$	t_{RESET}	–	–	10	μs
Falling Edge of \overline{CS} to Rising Edge of SCLK Required Setup Time	t_{LEAD}	100	–	–	ns
Falling Edge of SCLK to Rising Edge of \overline{CS} Required Setup Time	t_{LAG}	50	–	–	ns
SI to Falling Edge of SCLK Required Setup Time	$t_{SI(SU)}$	16	–	–	ns
Falling Edge of SCLK to SI Required Hold Time	$t_{SI(HOLD)}$	20	–	–	ns
SI, \overline{CS} , SCLK Signal Rise Time ⁽¹⁵⁾	$t_{R(SI)}$	–	5.0	–	ns
SI, \overline{CS} , SCLK Signal Fall Time ⁽¹⁵⁾	$t_{F(SI)}$	–	5.0	–	ns
Time from Falling Edge of \overline{CS} to SO Low Impedance ⁽¹⁶⁾	$t_{SO(EN)}$	–	–	55	ns
Time from Rising Edge of \overline{CS} to SO High Impedance ⁽¹⁷⁾	$t_{SO(DIS)}$	–	–	55	ns
Time from Rising Edge of SCLK to SO Data Valid ⁽¹⁸⁾	t_{VALID}	–	25	55	ns

Notes

13. These parameters are guaranteed by design. Production test equipment uses 4.16 MHz, 5.0V SPI interface.
14. This parameter is guaranteed by design but not production tested.
15. Rise and Fall time of incoming SI, \overline{CS} , and SCLK signals suggested for design consideration to prevent the occurrence of double pulsing.
16. Time required for valid output status data to be available on the SO pin.
17. Time required for output states data to be terminated at the SO pin.
18. Time required to obtain valid data out from SO following the rise of SCLK with a 200pF load.

TIMING DIAGRAMS

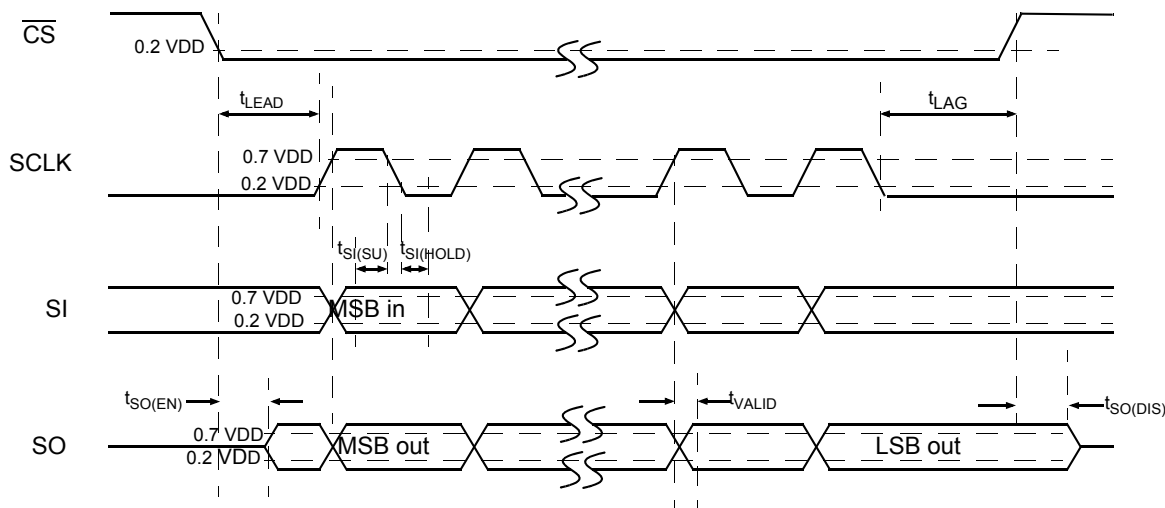

Figure 4. SPI Timing Characteristics

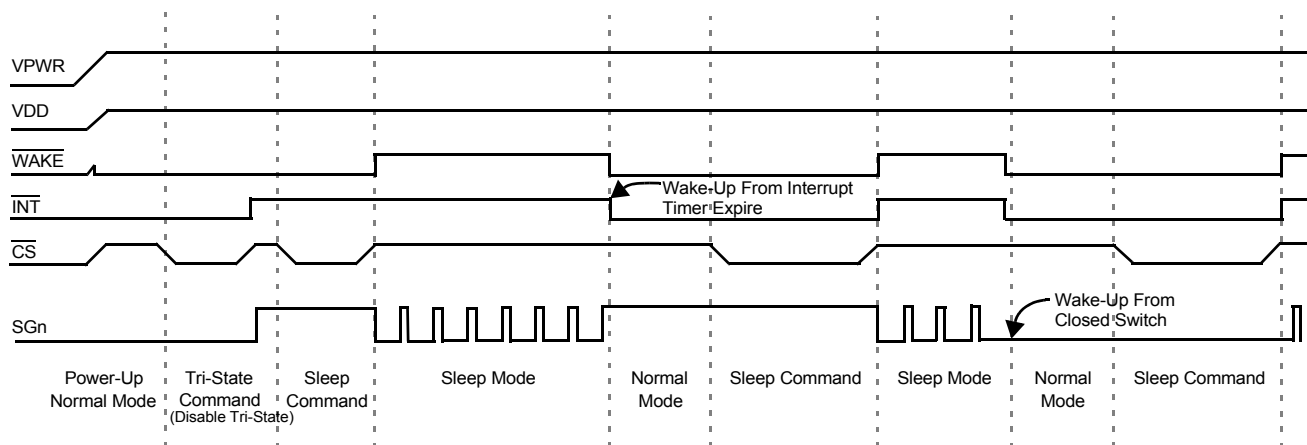

Figure 5. Sleep Mode to Normal Mode Operation

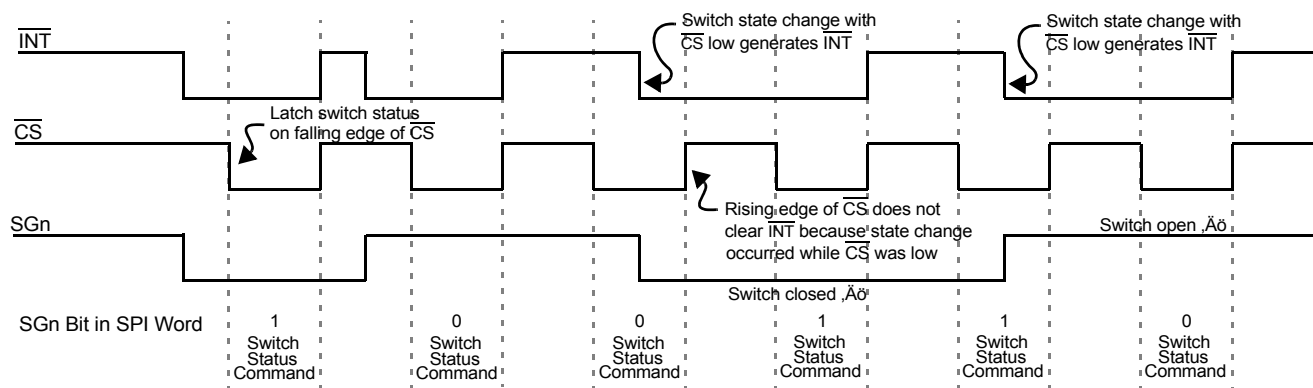

Figure 6. Normal Mode Interrupt Operation

FUNCTIONAL DESCRIPTIONS

INTRODUCTION

The 33975 device is an integrated circuit designed to provide systems with ultra-low quiescent sleep/wake-up modes and a robust interface between switch contacts and a microprocessor. The 33975 replaces many of the discrete components required when interfacing to microprocessor-based systems while providing switch ground offset protection, contact wetting current, and system wake-up.

The 33975 features 8-programmable switch-to-ground or switch-to-battery inputs and 14 switch-to-ground inputs. All

switch inputs may be read as analog inputs through the analog multiplexer (AMUX). Other features include a programmable wake-up timer, programmable interrupt timer, programmable wake-up/interrupt bits, and programmable wetting current settings.

This device is designed primarily for automotive applications but may be used in a variety of other applications such as computer, telecommunications, and industrial controls.

FUNCTIONAL PIN DESCRIPTION

CHIP SELECT (\overline{CS})

The system MCU selects the 33975 to receive communication using the chip select (\overline{CS}) pin. With \overline{CS} in a logic low state, command words may be sent to the 33975 via the serial input (SI) pin, and switch status information can be received by the MCU via the serial output (SO) pin. The falling edge of \overline{CS} enables the SO output, latches the state of the \overline{INT} pin, and the state of the external switch inputs.

Rising edge of the \overline{CS} initiates the following sequence:

1. Disables the SO driver (high-impedance)
2. \overline{INT} pin is reset to logic [1], except when additional switch changes occur during \overline{CS} low (see [Figure 6](#), page 11).
3. Activates the received command word, allowing the 33975 to act upon new data from switch inputs.

To avoid any spurious data, it is essential the high-to-low and low-to-high transitions of the \overline{CS} signal occur only when SCLK is in a logic low state. A clean \overline{CS} signal is needed to ensure no incomplete SPI words are sent to the device.

Internal to the 33975 device is an active pull-up to V_{DD} on \overline{CS} .

In Sleep Mode the negative edge of \overline{CS} (V_{DD} applied) will wake up the 33975 device. Data received from the device during \overline{CS} wake-up may not be accurate.

SERIAL CLOCK (SCLK)

The system clock (SCLK) pin clocks the internal shift register of the 33975. The SI data is latched into the input shift register on the falling edge of SCLK signal. The SO pin shifts the switch status bits out on the rising edge of SCLK. The SO data is available for the MCU to read on the falling edge of SCLK. False clocking of the shift register must be avoided to ensure validity of data. It is essential the SCLK pin be in a logic low state whenever \overline{CS} makes any transition. For this reason, it is recommended, though not necessary, that the SCLK pin is commanded to a low logic state as long as the device is not accessed and \overline{CS} is in a logic high state. When the \overline{CS} is in a logic high state, any signal on the SCLK and SI pin will be ignored and the SO pin is tri-state.

SERIAL INPUT (SI)

The SI pin is used for serial instruction data input. SI information is latched into the input register on the falling edge of SCLK. A logic high state present on SI will program a *one* in the command word on the rising edge of the \overline{CS} signal. To program a complete word, 24 bits of information must be entered into the device.

SERIAL OUTPUT (SO)

The SO pin is the output from the shift register. The SO pin remains tri-stated until the \overline{CS} pin transitions to a logic low state. All *open switches* are reported as a *zero*, all *closed switches* are reported as a *one*. The negative transition of \overline{CS} enables the SO driver.

The first positive transition of SCLK will make the status data bit 24 available on the SO pin. Each successive positive clock will make the next status data bit available for the MCU to read on the falling edge of SCLK. The SI/SO shifting of the data follows a first-in-first-out protocol, with both input and output words transferring the most significant bit (MSB) first.

INTERRUPT OUTPUT (\overline{INT})

The \overline{INT} pin is an interrupt output from the 33975 device. The \overline{INT} pin is an open-drain output with an internal pull-up to V_{DD} . In Normal mode, a switch state change will trigger the \overline{INT} pin (when enabled). The \overline{INT} pin is latched on the falling edge of \overline{CS} , and cleared on the rising edge of \overline{CS} . The \overline{INT} pin will not clear with rising edge of \overline{CS} if a switch contact change has occurred while the \overline{CS} was low.

In a multiple 33975 device system with \overline{WAKE} high and V_{DD} in (Sleep mode), the falling edge of \overline{INT} will place all 33975s in Normal mode.

WAKE INPUT (\overline{WAKE})

The \overline{WAKE} pin is an open-drain output and a wake-up input. The pin is designed to control a power supply Enable pin. In the Normal mode, the \overline{WAKE} pin is low. In the Sleep mode, the \overline{WAKE} pin is high. The \overline{WAKE} pin has a pull-up to the internal +5.0 V supply.

In Sleep mode with the $\overline{\text{WAKE}}$ pin high, the falling edge of $\overline{\text{WAKE}}$ will place the 33975 in Normal mode. In Sleep mode with V_{DD} applied, the $\overline{\text{INT}}$ pin must be high for a negative edge of $\overline{\text{WAKE}}$ to wake up the device. If V_{DD} is not applied to the device in Sleep mode, $\overline{\text{INT}}$ does not affect the $\overline{\text{WAKE}}$ operation.

LOAD SUPPLY VOLTAGE (VPWR)

The VPWR pin is battery input and Power-ON Reset to the 33975 IC. The VPWR pin requires external reverse battery and transient protection. The maximum input voltage on V_{PWR} is 50 V. All wetting, sustain, and internal logic current is provided from the V_{PWR} pin.

LOGIC VOLTAGE (VDD)

The VDD input pin is used to determine logic levels on the microprocessor interface (SPI) pins. Current from VDD is used to drive the SO output, and the pull-up current for $\overline{\text{CS}}$ and $\overline{\text{INT}}$ pins. VDD must be applied for a wake-up from the negative edge of $\overline{\text{CS}}$ or $\overline{\text{INT}}$.

GROUND (GND)

The GND pin provides ground for the IC as well as ground for inputs programmed as switch-to-battery inputs.

PROGRAMMABLE SWITCHES (SP0–SP7)

The 33975 device has 8 switch inputs capable of being programmed to read switch-to-ground or switch-to-battery contacts. The input is compared with a 4.0 V reference. When programmed to be switch-to-battery, voltages greater than 4.0 V are considered closed. Voltages less than 4.0 V are considered open. The opposite holds true when inputs are programmed as switch-to-ground. Programming features are defined in [Table 6](#) through [Table 11](#) in the [Functional Device Operation](#) section of this datasheet beginning on page [16](#). Voltages greater than the V_{PWR} supply voltage will source current through the SP inputs to the VPWR pin. Transient battery voltages greater than 38/40 V must be clamped by an external device.

SWITCH-TO-GROUND (SG0–SG13)

The SGn pins are switch-to-ground inputs only. The input is compared with a 4.0 V reference. Voltages greater than 4.0 V are considered open. Voltages less than 4.0 V are considered closed. Programming features are defined in [Table 6](#) through [Table 11](#) in the [Functional Device Operation](#) section of this datasheet beginning on page [16](#). Voltages greater than the V_{PWR} supply voltage will source current through the SG inputs to the VPWR pin. Transient battery voltages greater than 38/40 V must be clamped by an external device.

FUNCTIONAL INTERNAL BLOCK DESCRIPTION



Figure 7. Functional Internal Block Description

ANALOG CONTROL AND PROTECTION CIRCUITRY:

The 33975 is designed to operate from 5.5 V to 38/40 V on the VPWR pin. Characteristics are provided from 8.0 to 28 V for the device. Switch contact currents and the internal logic supply are generated from the VPWR pin. The VDD supply pin is used to set the SPI communication voltage levels, current source for the SO driver, and pull-up current on INT and CS.

The on-chip voltage regulator and bandgap supplies the required voltages to the internal monitor circuitry. The temperature monitor is active in the Normal Mode.

MCU INTERFACE AND CONTROL:

The 33975 Multiple Switch Detection Interface with Suppressed Wake-up is designed to detect the closing and opening of up to 22 switch contacts. The switch status, either open or closed, is transferred to the microprocessor unit (MCU) through a serial peripheral interface (SPI).

The device also features a 22-to-1 analog multiplexer for reading inputs as analog. The 33975 device has two modes of operation, Normal and Sleep.

SWITCH PROGRAMMABLE INPUTS:

Programmable switch detection inputs. These 8 inputs can selectively detect switch closures to ground or battery. The 33975 device has 8 switch inputs capable of being programmed to read switch-to-ground or switch-to-battery contacts. The input is compared with a 4.0 V reference. When programmed to be switch-to-battery, voltages greater than 4.0 V are considered closed. Voltages less than 4.0 V are considered open. The opposite holds true when inputs are programmed as switch-to-ground.

SWITCH-TO-GROUND INPUTS:

Switch detection interface inputs. These 14 inputs can detect switch closures to ground only. The input is compared with a 4.0 V reference. Voltages greater than 4.0 V are considered open. Voltages less than 4.0 V are considered closed. Note: Each of these inputs may be used to supply current to sensors external to a module.

MCU INTERFACE DESCRIPTION

The 33975 device directly interfaces to a 3.3 or 5.0 V microcontroller unit (MCU). SPI serial clock frequencies up to 6.0 MHz may be used for programming and reading switch input status (production tested at 4.16 MHz). [Figure 8](#) illustrates the configuration between an MCU and one 33975.

Serial peripheral interface (SPI) data is sent to the 33975 device through the SI input pin. As data is being clocked into the SI pin, status information is being clocked out of the device by the SO output pin. The response to a SPI command will always return the switch status, reset flag, and thermal flag. Input switch states are latched into the SO register on the falling edge of the chip select (\overline{CS}) pin. Twenty-four bits are required to complete a transfer of information between the 33975 and the MCU.

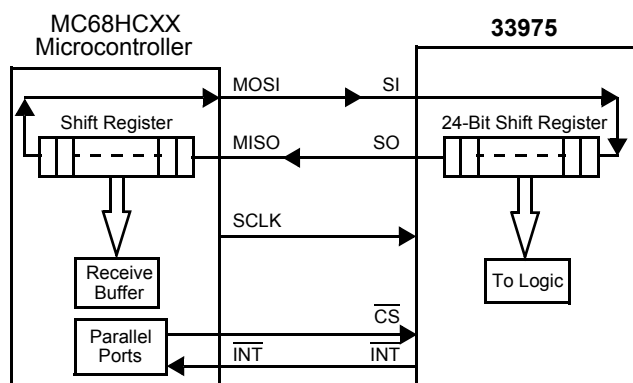

Figure 8. SPI Interface with Microprocessor

Two or more 33975 devices may be used in a module system. Multiple ICs may be SPI-configured in parallel or serial. [Figures 9](#) and [10](#) show the configurations. When using the serial configuration, 48-clock cycles are required to transfer data in/out of the ICs.

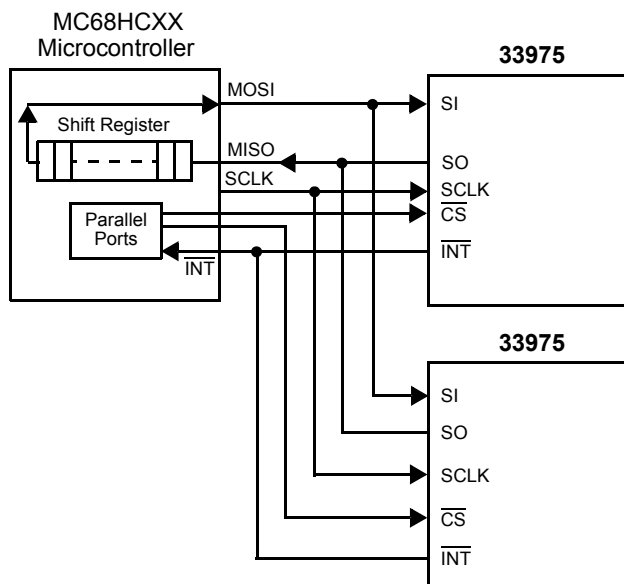

Figure 9. SPI Parallel Interface with Microprocessor

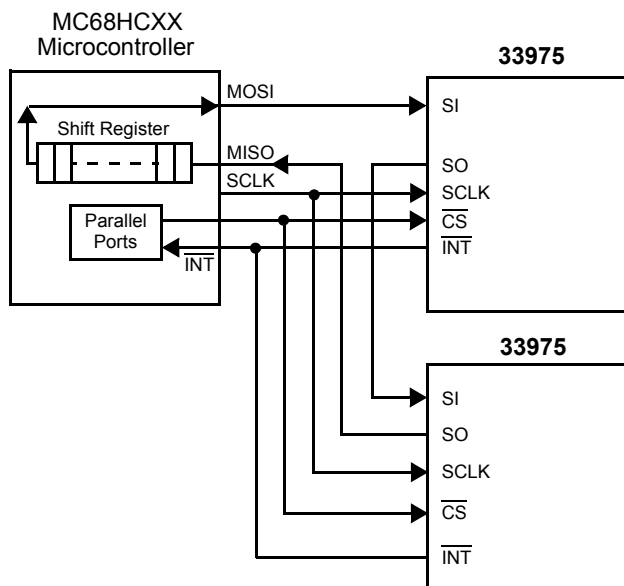

Figure 10. SPI Serial Interface with Microprocessor

FUNCTIONAL DEVICE OPERATION

POWER SUPPLY

The 33975 is designed to operate from 5.5 to 38/40 V on the VPWR pin. Characteristics are provided from 8.0 to 28 V for the device. Switch contact currents and the internal logic supply are generated from the VPWR pin. The VDD supply pin is used to set the SPI communication voltage levels, current source for the SO driver, and pull-up current on $\overline{\text{INT}}$ and $\overline{\text{CS}}$.

VDD supply may be removed from the device to reduce quiescent current. If VDD is removed while the device is in Normal mode, the device will remain in Normal mode. If VDD is removed in Sleep mode, the device will remain in Sleep mode until a wake-up input is received ($\overline{\text{WAKE}}$ high to low, switch input or interrupt timer expires).

Removing VDD from the device disables SPI communication and will not allow the device to wake up from the $\overline{\text{INT}}$ and $\overline{\text{CS}}$ pins.

POWER-ON RESET (POR)

Applying V_{PWR} to the device will cause a Power-ON Reset and place the device in Normal mode.

Default settings from Power-ON Reset via a VPWR or Reset Command are as follows:

- Programmable switch – Set to switch-to-battery
- All inputs set as wake-up
- Wetting current on (16 mA pull-down, 32 mA pull-up)
- Wetting current timer on (20 ms)
- All inputs tri-state
- Analog select 00000 (no input channel selected)

Note The 33975 device provides indication that a reset has occurred by placing a logic [1] in bit 22 of the SO buffer. The reset bit is cleared on rising edge of $\overline{\text{CS}}$.

OPERATIONAL MODES

The 33975 has two operating modes, Normal mode and Sleep mode. A discussion on Normal mode begins below. A discussion on [Sleep Mode](#) begins on page 21.

NORMAL MODE

Normal mode may be entered by the following events:

- Application of VPWR to the IC
- Change-of-switch state (when enabled)
- Falling edge of $\overline{\text{WAKE}}$
- Falling edge of $\overline{\text{INT}}$ (with $V_{\text{DD}} = 5.0 \text{ V}$ and $\overline{\text{WAKE}}$ at Logic [1])
- Falling edge of $\overline{\text{CS}}$ (with $V_{\text{DD}} = 5.0 \text{ V}$)
- Interrupt timer expires

Only in Normal mode with V_{DD} applied can the registers of the 33975 be programmed through the SPI.

The registers that may be programmed in Normal mode are listed below. Further explanation of each register is provided in subsequent paragraphs.

- [Programmable Switch Register](#) (*Settings Command*)
- [Wake-up/Interrupt Register](#) (*Wake-up/Interrupt Command*)
- [Wetting Current Register](#) (*Metallic Command*)
- [Wetting Current Timer Register](#) (*Wetting Current Timer Enable Command*)

- [Tri-state Register](#) (*Tri-state Command*)
- [Analog Select Register](#) (*Analog Command*)
- [Calibration of Timers](#) (*Calibration Command*)
- [Reset](#) (*Reset Command*)

[Figure 6](#), page 11, is a graphical description of the device operation in Normal mode. Switch states are latched into the input register on the falling edge of $\overline{\text{CS}}$. The $\overline{\text{INT}}$ to the MCU is cleared on the rising edge of $\overline{\text{CS}}$. However, $\overline{\text{INT}}$ will not clear on the rising edge of $\overline{\text{CS}}$ if a switch has closed during SPI communication ($\overline{\text{CS}}$ low). This prevents switch states from being missed by the MCU.

PROGRAMMABLE SWITCH REGISTER

Inputs SP0 to SP7 may be programmable for switch-to-battery or switch-to-ground. These inputs types are defined using the *settings command* (refer to [Table 6](#)). To set an SPn input for switch-to-battery, a logic [1] for the appropriate bit must be set. To set an SPn input for switch-to-ground, a logic [0] for the appropriate bit must be set. The MCU may change or update the Programmable Switch Register via software at any time in Normal mode. Regardless of the setting, when the SPn input switch is closed a logic [1] will be placed in the Serial Output Response Register (refer to [Table 17](#), page 21).

Table 6. Settings Command

Settings Command								Not used								Battery/Ground Select							
23	22	21	20	19	18	17	16	15	14	13	12	11	10	9	8	7	6	5	4	3	2	1	0
0	0	0	0	0	0	0	1	X	X	X	X	X	X	X	X	sp7	sp6	sp5	sp4	sp3	sp2	sp1	sp0

WAKE-UP/INTERRUPT REGISTER

The Wake-up/Interrupt Register defines the inputs that are allowed to wake the 33975 from Sleep mode or set the $\overline{\text{INT}}$ pin low in Normal mode. Programming the wake-up/interrupt bit to logic [0] will disable the specific input from generating an interrupt and will disable the specific input from waking the

IC in Sleep mode (refer to [Table 7](#)). Programming the wake-up/interrupt bit to logic [1] will enable the specific input to generate an interrupt with switch change of state and will enable the specific input as wake-up. The MCU may change or update the Wake-up/Interrupt Register via software at any time in Normal mode.

Table 7. Wake-Up/Interrupt Command

Wake-up/Interrupt Command								Command Bits															
23	22	21	20	19	18	17	16	15	14	13	12	11	10	9	8	7	6	5	4	3	2	1	0
0	0	0	0	0	0	1	0	X	X	X	X	X	X	X	X	sp7	sp6	sp5	sp4	sp3	sp2	sp1	sp0
0	0	0	0	0	0	1	1	X	X	sg1 3	sg1 2	sg1 1	sg1 0	sg9	sg8	sg7	sg6	sg5	sg4	sg3	sg2	sg1	sg0

WETTING CURRENT REGISTER

The 33975 has two levels of switch-to-ground contact current, 32 and 4.0 mA, and two levels of switch-to-battery contact current, 16 and 2.0 mA (see [Figure 11](#)). The *metallic command* is used to set the switch contact current level (refer to [Table 8](#)). Programming the metallic bit to logic [0] will set the switch wetting current to 2.0 mA/4.0 mA. Programming the metallic bit to logic [1] will set the switch contact wetting current to 16 mA/32 mA. The MCU may change or update the Wetting Current Register via software at any time in Normal Mode.

Wetting current is designed to provide higher levels of current during switch closure. The higher level of current is designed to keep switch contacts from building up oxides that form on the switch contact surface.

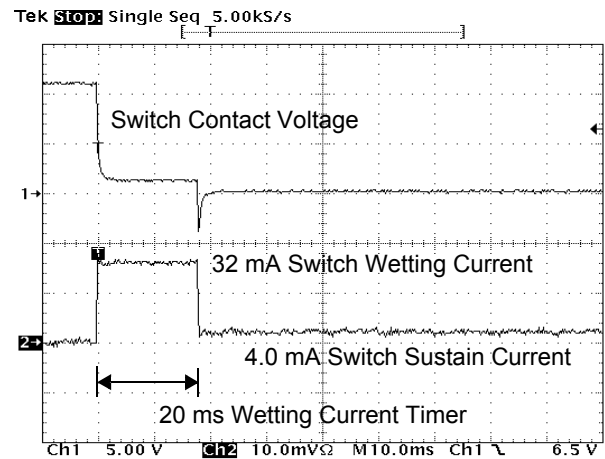

Figure 11. Contact Wetting and Sustain Current for Switch-to-Ground Input

Table 8. Metallic Command

Metallic Command								Command Bits															
23	22	21	20	19	18	17	16	15	14	13	12	11	10	9	8	7	6	5	4	3	2	1	0
0	0	0	0	0	1	0	0	X	X	X	X	X	X	X	X	sp7	sp6	sp5	sp4	sp3	sp2	sp1	sp0
0	0	0	0	0	1	0	1	X	X	sg1 3	sg1 2	sg1 1	sg1 0	sg9	sg8	sg7	sg6	sg5	sg4	sg3	sg2	sg1	sg0

WETTING CURRENT TIMER REGISTER

Each switch input has a designated 20 ms timer. The timer starts when the specific switch input crosses the comparator threshold (4.0 V). When the 20 ms timer expires, the contact current is reduced from 16 to 2.0 mA for switch-to-battery inputs and 32 to 4.0 mA for switch-to-ground inputs. The wetting current timer may be disabled for a specific input. When the timer is disabled, wetting current will continue to flow through the closed switch contact. With multiple wetting

current timers disabled, power dissipation for the IC must be considered.

The MCU may change or update the Wetting Current Timer Register via software at any time in Normal mode. This allows the MCU to control the amount of time wetting current is applied to the switch contact. Programming the wetting current timer bit to logic [0] will disable the wetting current timer. Programming the wetting current timer bit to logic [1] will enable the wetting current timer (refer to [Table 9](#)).

Table 9. Wetting Current Timer Enable Command

Wetting Current Timer Commands								Command Bits															
23	22	21	20	19	18	17	16	15	14	13	12	11	10	9	8	7	6	5	4	3	2	1	0
0	0	0	0	0	1	1	1	X	X	X	X	X	X	X	X	sp7	sp6	sp5	sp4	sp3	sp2	sp1	sp0
0	0	0	0	1	0	0	0	X	X	sg13	sg12	sg11	sg10	sg9	sg8	sg7	sg6	sg5	sg4	sg3	sg2	sg1	sg0

TRI-STATE REGISTER

The *tri-state command* is used to set the SPn or SGn input node as high-impedance (refer to [Table 10](#)). By setting the Tri-state Register bit to logic [1], the input will be high-impedance regardless of the metallic command setting. The

comparator on each input remains active. This command allows the use of each input as a comparator with a 4.0 V threshold. The MCU may change or update the Tri-state Register via software at any time in Normal mode.

Table 10. Tri-state Command

Tri-State Commands								Command Bits															
23	22	21	20	19	18	17	16	15	14	13	12	11	10	9	8	7	6	5	4	3	2	1	0
0	0	0	0	1	0	0	1	X	X	X	X	X	X	X	X	sp7	sp6	sp5	sp4	sp3	sp2	sp1	sp0
0	0	0	0	1	0	1	0	X	X	sg13	sg12	sg11	sg10	sg9	sg8	sg7	sg6	sg5	sg4	sg3	sg2	sg1	sg0

ANALOG SELECT REGISTER

The analog voltage on switch inputs may be read by the MCU using the *analog command* (refer to [Table 11](#)). Internal to the IC is a 22-to-1 analog multiplexer. The voltage present on the selected input pin is buffered and made available on the AMUX output pin. The AMUX output pin is clamped to a maximum of VDD volts regardless of the higher voltages present on the input pin. After an input has been selected as the analog, the corresponding bit in the next SO data stream will be logic [0]. When selecting a channel to be read as analog, the user must also set the desired current (32 mA, 4.0 mA, or high-impedance). Setting bit 6 and bit 5 to 0,0

selects the input as high-impedance. Setting bit 6 and bit 5 to 0,1 selects 4.0 mA, and 1,0 selects 32 mA. Setting bit 6 and bit 5 to 1,1 in the Analog Select Register is not allowed and will place the input as an analog input with high-impedance.

Analog currents set by the *analog command* are pull-up currents for all SGn and SPn inputs (refer to [Table 11](#)). The *analog command* does not allow pull-down currents on the SPn inputs. Setting the current to 32 or 4.0 mA may be useful for reading sensor inputs. Further information is provided in the [Typical Applications](#) section of this datasheet beginning on page [23](#). The MCU may change or update the Analog Select Register via software at any time in Normal mode.

Table 11. Analog Command

Analog Command								Not used								Current Select		Analog Channel Select					
23	22	21	20	19	18	17	16	15	14	13	12	11	10	9	8	7	6	5	4	3	2	1	0
0	0	0	0	0	1	1	0	X	X	X	X	X	X	X	X	X	32 mA	4.0 mA	0	0	0	0	0

Table 12. Analog Channel

Bits 43210	Analog Channel Select
00000	No Input Selected
00001	SG0
00010	SG1
00011	SG2
00100	SG3
00101	SG4
00110	SG5
00111	SG6
01000	SG7
01001	SG8
01010	SG9
01011	SG10
01100	SG11
01101	SG12
01110	SG13
01111	SP0
10000	SP1
10001	SP2
10010	SP3
10011	SP4
10100	SP5
10101	SP6
10110	SP7

CALIBRATION OF TIMERS

In cases where an accurate time base is required, the user may calibrate the internal timers using the *calibration command* (refer to [Table 13](#)). After the 33975 device receives the calibration command, the device expects 512 μ s logic [0] calibration pulse on the \overline{CS} pin. The pulse is used to calibrate the internal clock. No other SPI pins should transition during this 512 μ s calibration pulse. Because the

oscillator frequency changes with temperature, calibration is required for an accurate time base. Calibrating the timers has no affect on the quiescent current measurement. The calibration command simply makes the time base more accurate. The *calibration command* may be used to update the device on a periodic basis. All reset conditions clear the calibration register and places the device in the uncalibrated state.

Table 13. Calibration Command

Calibration Command								Command Bits															
23	22	21	20	19	18	17	16	15	14	13	12	11	10	9	8	7	6	5	4	3	2	1	0
0	0	0	0	1	0	1	1	X	X	X	X	X	X	X	X	X	X	X	X	X	X	X	X

RESET

The reset command resets all registers to Power-ON Reset (POR) state. Refer to [Table](#), page [20](#), for POR states or the

paragraph entitled [Power-ON Reset \(POR\)](#) on page [16](#) of this datasheet.

Table 14. Reset Command

Reset Command								Command Bits															
23	22	21	20	19	18	17	16	15	14	13	12	11	10	9	8	7	6	5	4	3	2	1	0
0	1	1	1	1	1	1	1	X	X	X	X	X	X	X	X	X	X	X	X	X	X	X	X

SPI COMMAND SUMMARY

Table below provides a comprehensive list of SPI commands recognized by the 33975 and the reset state of each register. Table 16 and Table 17 contain the Serial

Output (SO) data for input voltages greater or less than the threshold level. Open switches are always indicated with a logic [0], closed switches are indicated with logic [1].

Table 15. SPI Command Summary

	MSB								Command Bits								Setting Bits								LSB			
	23	22	21	20	19	18	17	16	15	14	13	12	11	10	9	8	7	6	5	4	3	2	1	0				
Switch Status Command	0	0	0	0	0	0	0	0	X	X	X	X	X	X	X	X	X	X	X	X	X	X	X	X				
Settings Command Bat=1, Gnd=0 (Default state = 1)	0	0	0	0	0	0	0	1	X	X	X	X	X	X	X	X	SP7	SP6	SP5	SP4	SP3	SP2	SP1	SP0				
Wake-up/Interrupt Bit Wake-up=1 Nonwake-up=0 (Default state = 1)	0	0	0	0	0	0	1	0	X	X	X	X	X	X	X	X	SP7	SP6	SP5	SP4	SP3	SP2	SP1	SP0				
	0	0	0	0	0	0	1	1	X	X	SG1 3	SG1 2	SG1 1	SG1 0	SG9	SG8	SG7	SG6	SG5	SG4	SG3	SG2	SG1	SG0				
Metallic Command Metallic = 1 Non-metallic = 0 (Default state = 1)	0	0	0	0	0	1	0	0	X	X	X	X	X	X	X	X	SP7	SP6	SP5	SP4	SP3	SP2	SP1	SP0				
	0	0	0	0	0	1	0	1	X	X	SG1 3	SG1 2	SG1 1	SG1 0	SG9	SG8	SG7	SG6	SG5	SG4	SG3	SG2	SG1	SG0				
Analog Command	0	0	0	0	0	1	1	0	X	X	X	X	X	X	X	X	X	32mA 0	4.0mA 0	0	0	0	0	0				
Wetting Current Timer Enable Command Timer ON = 1 Timer OFF = 0 (Default state = 1)	0	0	0	0	0	1	1	1	X	X	X	X	X	X	X	X	SP7	SP6	SP5	SP4	SP3	SP2	SP1	SP0				
	0	0	0	0	1	0	0	0	X	X	SG1 3	SG1 2	SG1 1	SG1 0	SG9	SG8	SG7	SG6	SG5	SG4	SG3	SG2	SG1	SG0				
Tri-state Command Input Tri-state=1	0	0	0	0	1	0	0	1	X	X	X	X	X	X	X	X	SP7	SP6	SP5	SP4	SP3	SP2	SP1	SP0				
	0	0	0	0	1	0	1	0	X	X	SG1 3	SG1 2	SG1 1	SG1 0	SG9	SG8	SG7	SG6	SG5	SG4	SG3	SG2	SG1	SG0				
Calibration Command (Default state - uncalibrated)	0	0	0	0	1	0	1	1	X	X	X	X	X	X	X	X	X	X	X	X	X	X	X	X				
Sleep Command (See Sleep Mode on page 21)	0	0	0	0	1	1	0	0	X	X	X	X	X	X	X	X	X	X	int timer	int timer	int timer	scan timer	scan timer	scan timer				
Reset Command	0	1	1	1	1	1	1	1	X	X	X	X	X	X	X	X	X	X	X	X	X	X	X	X				
SO Response Will Always Send	therm flg	RST flg	SP7	SP6	SP5	SP4	SP3	SP2	SP1	SP0	SG1 3	SG1 2	SG1 1	SG1 0	SG9	SG8	SG7	SG6	SG5	SG4	SG3	SG2	SG1	SG0				

Table 16. Serial Output (SO) Bit Data

Type of Input	Input Programmed	Voltage on Input Pin	SO SPI Bit
SP	Switch to Ground	SPn < 4.0 V	1
	Switch to Ground	SPn > 4.0 V	0
	Switch to Battery	SPn < 4.0 V	0
	Switch to Battery	SPn > 4.0 V	1
SG	N/A	SGn < 4.0 V	1
	N/A	SGn > 4.0 V	0

Table 17. Serial Output (SO) Response Register

SO Response Will Always Send	therm flg	RST flg	SP7	SP6	SP5	SP4	SP3	SP2	SP1	SP0	SG3	SG2	SG1	SG0	SG9	SG8	SG7	SG6	SG5	SG4	SG3	SG2	SG1	SG0

EXAMPLE OF NORMAL MODE OPERATION

The operation of the device in Normal mode is defined by the states of the programmable internal control registers. A typical application may have the following settings:

- Programmable switch – set to switch-to-ground
- All inputs set as wake-up
- Wetting current on (32 mA)
- Wetting current timer on (20 ms)
- All inputs tri-state-disabled (comparator is active)
- Analog select 00000 (no input channel selected)

With the device programmed as above, an interrupt will be generated with each switch contact change of state (open-to-close or close-to-open) and 32 mA of contact wetting current will be source for 20 ms. The $\overline{\text{INT}}$ pin will remain low until switch status is acknowledged by the microprocessor. It is critical to understand $\overline{\text{INT}}$ will not be cleared on the rising edge of $\overline{\text{CS}}$ if a switch closure occurs while the $\overline{\text{CS}}$ is low. The maximum duration a switch state change can exist without acknowledgement depends on the software response time to the interrupt. [Figure 6](#), page 11, shows the interaction between changing input states and the $\overline{\text{INT}}$ and $\overline{\text{CS}}$ pins.

If desired the user may disable interrupts (*wake-up/interrupt command*) from the 33975 device and read the switch states on a periodic basis. Switch activation and deactivation faster than the MCU read rate will not be acknowledged.

The 33975 device will exit the Normal mode and enter the Sleep mode only with a valid sleep command.

SLEEP MODE

Sleep mode is used to reduce system quiescent currents. Sleep mode may be entered only by sending the *sleep command*. All register settings programmed in Normal mode will be maintained in Sleep mode.

The 33975 will exit Sleep mode and enter Normal mode when any of the following events occur:

- Input switch change of state (when enabled)
- Interrupt timer expire
- Falling edge of $\overline{\text{WAKE}}$
- Falling edge of $\overline{\text{INT}}$ (with VDD = 5.0 V and $\overline{\text{WAKE}}$ at Logic [1])
- Falling edge of $\overline{\text{CS}}$ (with VDD = 5.0 V)
- Power-on reset (POR)

The VDD supply may be removed from the device during Sleep mode. However removing VDD from the device in Sleep mode will disable a wake-up from falling edge of $\overline{\text{INT}}$ and $\overline{\text{CS}}$.

Note: In cases where $\overline{\text{CS}}$ is used to wake the device, the first SO data message is not valid.

The sleep command contains settings for two programmable timers for Sleep mode, the interrupt timer and the scan timer, as shown in [Table 18](#).

Table 18. Sleep Command

Sleep Command								Command Bits															
23	22	21	20	19	18	17	16	15	14	13	12	11	10	9	8	7	6	5	4	3	2	1	0
0	0	0	0	1	1	0	0	X	X	X	X	X	X	X	X	X	X	int timer	int timer	int timer	scan timer	scan timer	scan timer

The interrupt timer is used as a periodic wake-up timer. When the timer expires, an interrupt is generated and the device enters Normal mode.

Note: The interrupt timer in the 33975 device may be disabled by programming the interrupt bits to logic [1 1 1].

[Table 19](#) shows the programmable settings of the Interrupt timer.

The scan timer sets the polling period between input switch reads in Sleep mode. The period is set in the *sleep command* and may be set to 000 (no period) to 111 (64 ms). In Sleep mode when the scan timer expires, inputs will behave as programmed prior to sleep command. The 33975 will wake up for approximately 125 μ s and read the switch inputs. At the end of the 125 μ s, the input switch states are compared with the switch state prior to sleep command. When switch state changes are detected, an interrupt (when enabled; refer to *wake-up/interrupt command* description on [page 17](#)) is generated and the device enters Normal mode. Without switch state changes, the 33975 will reset the scan timer, inputs become tri-state, and the Sleep mode continues until the scan timer expires again.

[Table 20](#) shows the programmable settings of the Scan timer.

Note: The interrupt and scan timers are disabled in the Normal Mode.

Table 19. Interrupt Timer

Bits 543	Interrupt Period
000	32 ms
001	64 ms
010	128 ms
011	256 ms
100	512 ms
101	1.024 s
110	2.048 s
111	No interrupt wake-up

Table 20. Scan Timer

Bits 210	Scan Period
000	No Scan
001	1.0 ms
010	2.0 ms
011	4.0 ms
100	8.0 ms
101	16 ms
110	32 ms
111	64 ms

[Figure 5](#), page 11, is a graphical description of how the 33975 device exits Sleep mode and enters Normal mode. Notice that the device will exit Sleep mode when the interrupt timer expires or when a switch change of state occurs. The falling edge of INT triggers the MCU to wake from Sleep state. [Figure 12](#) illustrates the current consumed during Sleep mode. During the 125 μ s, the device is fully active and switch states are read. The quiescent current is calculated by integrating the normal running current over scan period plus approximately 60 μ A.



Figure 12. Sleep Current Waveform

TEMPERATURE MONITOR

With multiple switch inputs closed and the device programmed with the wetting current timers disabled, considerable power will be dissipated by the IC. For this reason temperature monitoring has been implemented. The temperature monitor is active in the Normal mode only. When the IC temperature is above the thermal limit, the temperature monitor will do all of the following:

- Generate an interrupt.
- Force all wetting current sources to revert to 2.0 mA/ 4.0 mA sustain currents
- Maintain the 2.0 mA/4.0 mA sustain currents and all other functionality.
- Set the thermal flag bit in the SPI output register.

The thermal flag bit in the SPI word will be cleared on the rising edge of CS provided the die temperature has cooled below the thermal limit. When die temperature has cooled below thermal limit, the device will resume previously programmed settings.

TYPICAL APPLICATIONS

The 33975's primary function is the detection of open or closed switch contacts. However, there are many features that allow the device to be used in a variety of applications. The following is a list of applications to consider for the IC:

- Sensor power supply
- Switch monitor for metallic or elastomeric switches
- Analog sensor inputs (Ratiometric)
- Power MOSFET/LED driver and monitor
- Multiple 33975 devices in a module system

The following paragraphs describe the applications in detail.

SENSOR POWER SUPPLY

Each input may be used to supply current to sensors external to a module. Many sensors such as Hall effect, pressure sensors, and temperature sensors require a supply voltage to power the sensor, and provide an open collector or analog output. [Figure 13](#) shows how the 33975 may be used to supply power and interface to these types of sensors. In an application where the input makes continuous transitions, consider using the *wake-up/interrupt command* to disable the interrupt for the particular input.

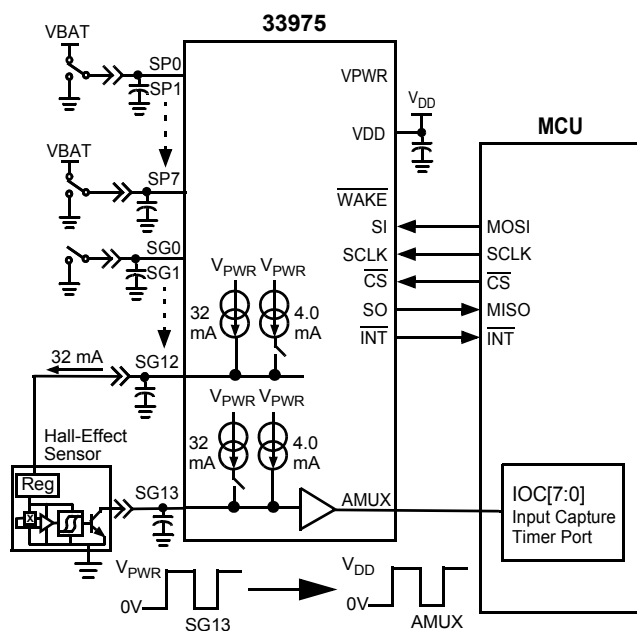

Figure 13. Sensor Power Supply

METALLIC/ELASTOMERIC SWITCH

Metallic switch contacts often develop higher contact resistance over time owing to contact corrosion. The corrosion is induced by humidity, salt, and other elements that exist in the environment. For this reason the 33975 provides two settings for contacts. When programmed for metallic switches, the device provides higher wetting current to keep switch contacts free of oxides. The higher current occurs for the first 20 ms of switch closure. Where longer duration of wetting current is desired, the user may send the *wetting current timer command* and disable the timer. Wetting current will be continuous to the closed switch. After the time period set by the MCU, the *wetting current timer command* may be sent again to enable the timer. The user must consider power dissipation on the device when disabling the timer. (Refer to the paragraph entitled [Temperature Monitor](#), page 22.)

To increase the amount of wetting current for a switch contact, the user has two options. Higher wetting current to a switch may be achieved by paralleling SGn or SPn inputs. This will increase wetting current by 32 mA for each input added to the switch-to-ground contact and 16 mA for switch-to-battery contacts. The second option is to simply add an external resistor pull-up to the V_{PWR} supply for switch-to-ground inputs or a resistor to ground for a switch-to-battery input. Adding an external resistor has no effect on the operation of the device.

Elastomeric switch contacts are made of carbon and have a high contact resistance. Resistance of 1.0 kΩ is common. In applications with elastomeric switches, the pull-up and pull-down currents must be reduced to prevent excessive power dissipation at the contact. Programming for a lower current settings is provided in the [Functional Device Operation](#) Section beginning on page 16 under [Table 8](#), Metallic Command.

ANALOG SENSOR INPUTS (RATIOMETRIC)

The 33975 features a 22-to-1 analog multiplexer. Setting the binary code for a specific input in the *analog command* allows the microcontroller to perform analog to digital conversion on any of the 22 inputs. On rising edge of the CS, the multiplexer connects a requested input to the AMUX pin. The AMUX pin is clamped to max of V_{DD} volts regardless of the higher voltages present on the input pin. After an input has been selected as the analog, the corresponding bit in the next SO data stream will be logic [0].

The input pin, when selected as analog, may be configured as analog with high-impedance, analog with 4.0 mA pull-up, or analog with 32 mA pull-up. [Figure 14](#), page 24, shows how the 33975 may be used to provide a ratiometric reading of variable resistive input.

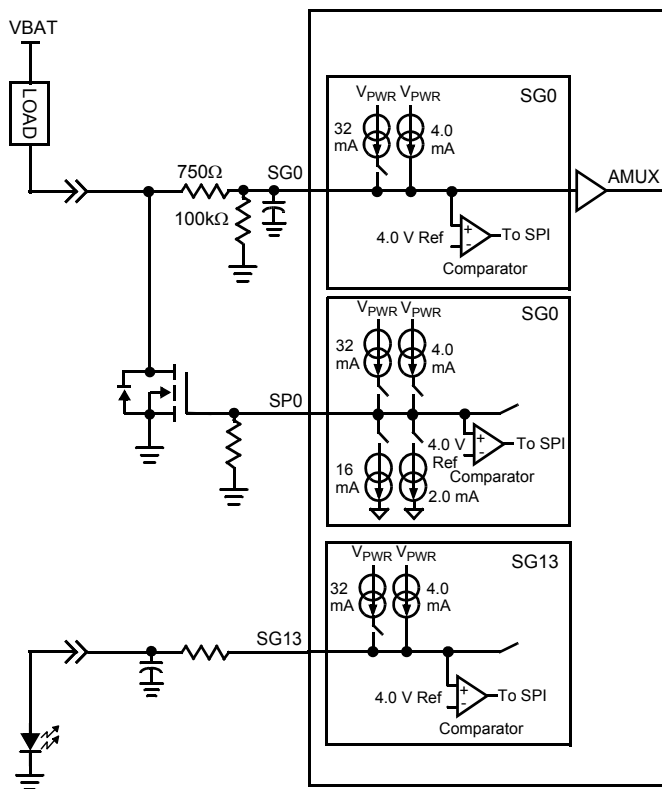

Figure 15. MOSFET or LED Driver Output

The sequence of commands (from Normal mode with inputs tri-state) required to set up the device to drive a MOSFET are as follows:

- *wetting current timer enable command* –Disable SPn wetting current timer (refer to [Table 9](#), page 18).
- *metallic command* –Set SPn to 16/32 mA or 2.0/4.0 mA gate drive current (refer to [Table 8](#), page 17).
- *settings command* –Set SPn as switch-to-battery (refer to [Table 6](#), page 16).
- *tri-state command* –Disable tri-state for SPn (refer to [Table 10](#), page 18).

After the *tri-state command* has been sent (tri-state disable), the MOSFET gate will be pulled to ground. From this point forward the MOSFET may be turned on and off by sending the *settings command*:

- *settings command* –SPn as switch-to-ground (MOSFET ON).
- *settings command* –SPn as switch-to-battery (MOSFET OFF).

Monitoring of the MOSFET drain in the OFF state provides open load detection. This is done by using an input comparator. With the SGn input in tri-state, the load will pull up the input to battery. With the load open, the SGn pin is pulled down to ground through an external resistor. The open load is indicated by a logic [1] in the SO data bit.

The *analog command* may be used to monitor the drain voltage in the MOSFET ON state. By sourcing 4.0 mA of

current to the 750 Ω resistor, the analog voltage on the SGn pin will be approximately:

$$V_{SGn} = I_{SGn} \times 750\Omega + V_{DS}$$

As the voltage on the drain of the MOSFET increases, so does the voltage on the SGn pin. With the SGn pin selected as analog, the MCU may perform the A/D conversion.

Using this method for controlling unclamped inductive loads is not recommended. Inductive fly-back voltages greater than V_{PWR} may damage the IC.

The SP0–SP7 pins of this device may also be used to send signals from one module to another. Operation is similar to the gate control of a MOSFET.

For LED applications a resistor in series with the LED is recommended but not required. The switch-to-ground inputs are recommended for LED application. To drive the LED use the following commands:

- *wetting current timer enable command* –Disable SGn wetting current timer.
- *metallic command* –Set SGn to 32 mA.

From this point forward the LED may be turned on and off using the *tri-state command*:

- *tri-state command* –Disable tri-state for SGn (LED ON).
- *tri-state command* –Enable tri-state for SGn (LED OFF).

These parameters are easily programmed via SPI commands in Normal mode.

Multiple 33975 Devices in a Module System

Connecting power to the 33975 and the MCU for Sleep mode operation may be done in several ways. [Table 21](#) shows several system configurations for power between the MCU and the 33975 and their specific requirements for functionality.

Table 21. Sleep Mode Power Supply

MCU VDD	33975 VDD	Comments
5.0V	5.0V	All wake-up conditions apply. (Refer to Sleep Mode , page 21.)
5.0V	0V	SPI wake-up is not possible.
0V	5.0V	Sleep mode is not possible. Current from the \overline{CS} pull-up will flow through the MCU to the VDD that has been switched off. The negative edge of \overline{CS} will put 33975 in Normal mode.
0V	0V	SPI wake-up is not possible.

Multiple 33975 devices may be used in a module system. SPI control may be done in parallel or serial. However when parallel mode is used, each device is addressed independently (refer to [MCU Interface Description](#), page 15).

Therefore, when sending the *sleep command*, one device will enter sleep before the other. For multiple devices in a system, it is recommended that the devices are controlled in serial (S0 from first device is connected to SI of second device). With two devices, 48 clock pulses are required to shift data in. When the $\overline{\text{WAKE}}$ feature is used to enable the power supply, both $\overline{\text{WAKE}}$ pins should be connected to the enable pin on the power supply. The $\overline{\text{INT}}$ pins may be connected to one interrupt pin on the MCU, or may have their own dedicated interrupt to the MCU.

The transition from Normal to Sleep mode is done by sending the *sleep command*. With the devices connected in serial and the *sleep command* sent, both will enter Sleep mode on the rising edge of $\overline{\text{CS}}$. When Sleep mode is entered, the $\overline{\text{WAKE}}$ pin will be logic [1]. If either device wakes up, the $\overline{\text{WAKE}}$ pin will transition low, waking the other device.

A condition exists where the MCU is sending the *sleep command* ($\overline{\text{CS}}$ logic [0]) and a switch input changes state. With this event, the device that detects this input will not transition to Sleep mode, while the second device will enter Sleep mode. In this case, two *switch status commands* must be sent to receive accurate switch status data. The first *switch status command* will wake the device in Sleep mode. Switch status data may not be valid from the first *switch status command* because of the time required for the input voltage to rise above the 4.0 V input comparator threshold. This time is dependant on the impedance of S_{Gn} or S_{Pn} node. The second *switch status command* will provide accurate switch status information. It is recommended that the software wait 10 to 20 ms between the two *switch status commands*, allowing time for switch input voltages to stabilize. With all switch states acknowledged by the MCU, the sleep sequence may be initiated. All parameters for Sleep mode should be updated prior to sending the *sleep command*.

The 33975 IC has an internal 5.0 V supply from the VPWR pin. A POR circuit monitors the internal 5.0 V supply. In the event of transients on the VPWR pin, an internal reset may occur. Upon reset the 33975 will enter Normal mode with the internal registers as defined in [Table](#), page 20. Therefore it is recommended that the MCU periodically update all registers internal to the IC.

USING THE $\overline{\text{WAKE}}$ FEATURE

The 33975 provides a $\overline{\text{WAKE}}$ output and wake-up input designed to control an enable pin on system power supply. While in the Normal mode, the $\overline{\text{WAKE}}$ output is low, enabling the power supply. In the Sleep mode, the $\overline{\text{WAKE}}$ pin is high, disabling the power supply. The $\overline{\text{WAKE}}$ pin has a passive pull-up to the internal 5.0 V supply but may be pulled up through a resistor to V_{PWR} supply (see [Figure 17](#), page 27).

When the $\overline{\text{WAKE}}$ output is not used the pin should be pulled up to the VDD supply through a resistor, as shown in [Figure 16](#), page 27).

During the Sleep mode, a switch closure will set the $\overline{\text{WAKE}}$ pin low, causing the 33975 to enter the Normal mode. The power supply will then be activated, supplying power to the VDD pin and the microprocessor and the 33975. The microprocessor can determine the source of the wake-up by reading the interrupt flag.

COST AND FLEXIBILITY

Systems requiring a significant number of switch interfaces have many discrete components. Discrete components on standard PWB consume board space and must be checked for solder joint integrity. An integrated approach reduces solder joints, consumes less board space, and offers wider operating voltage, analog interface capability, and greater interfacing flexibility.

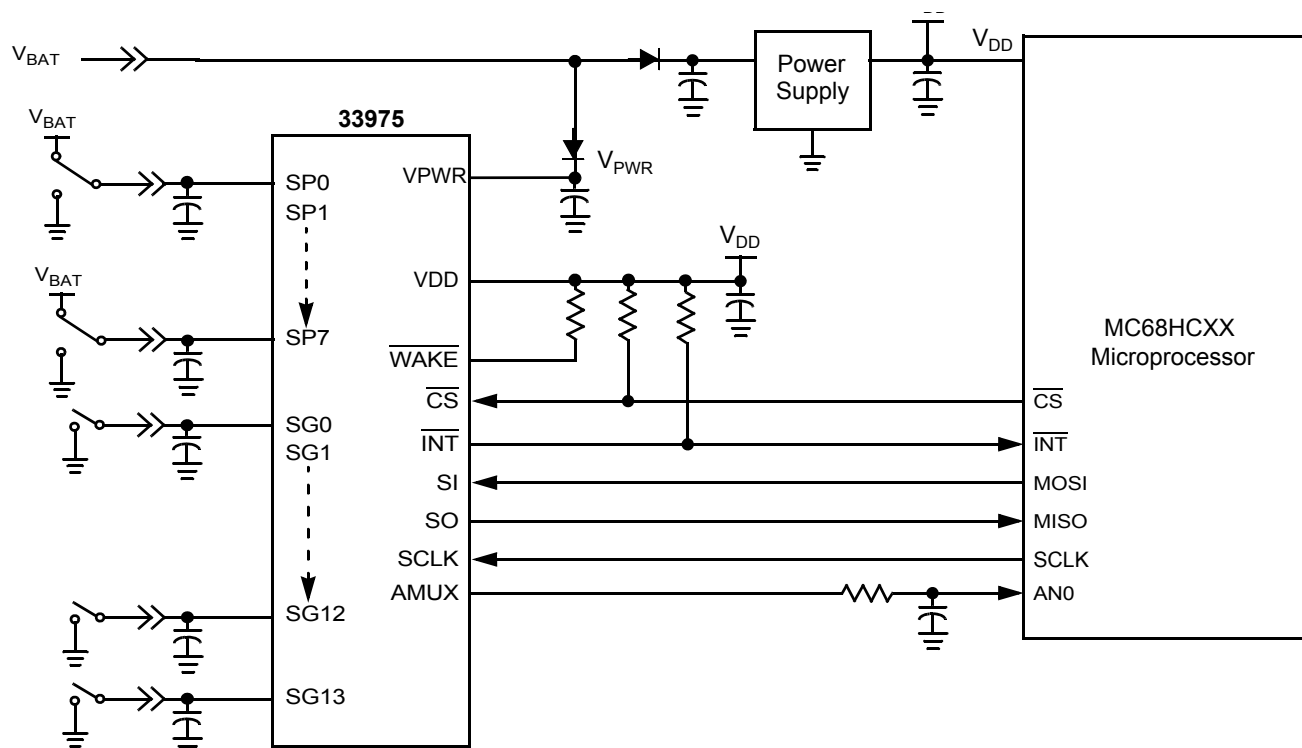

Figure 16. Power Supply Active in Sleep Mode

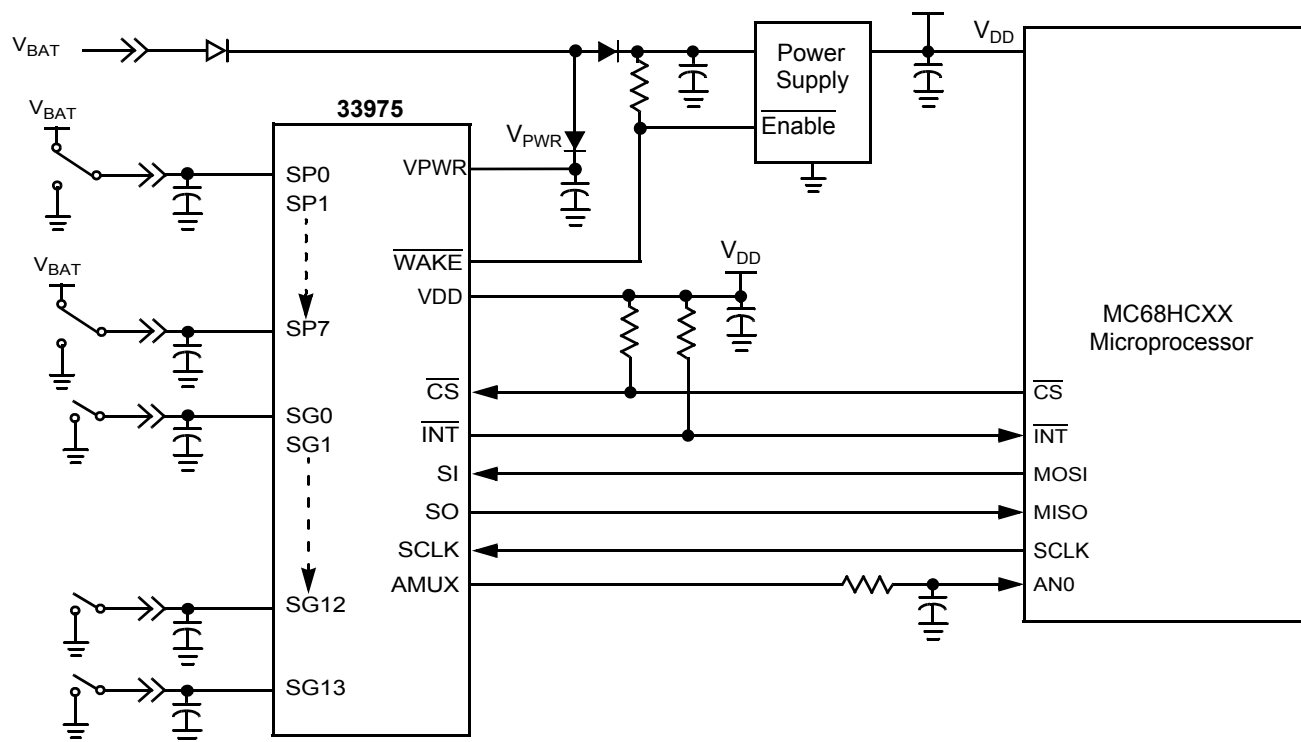
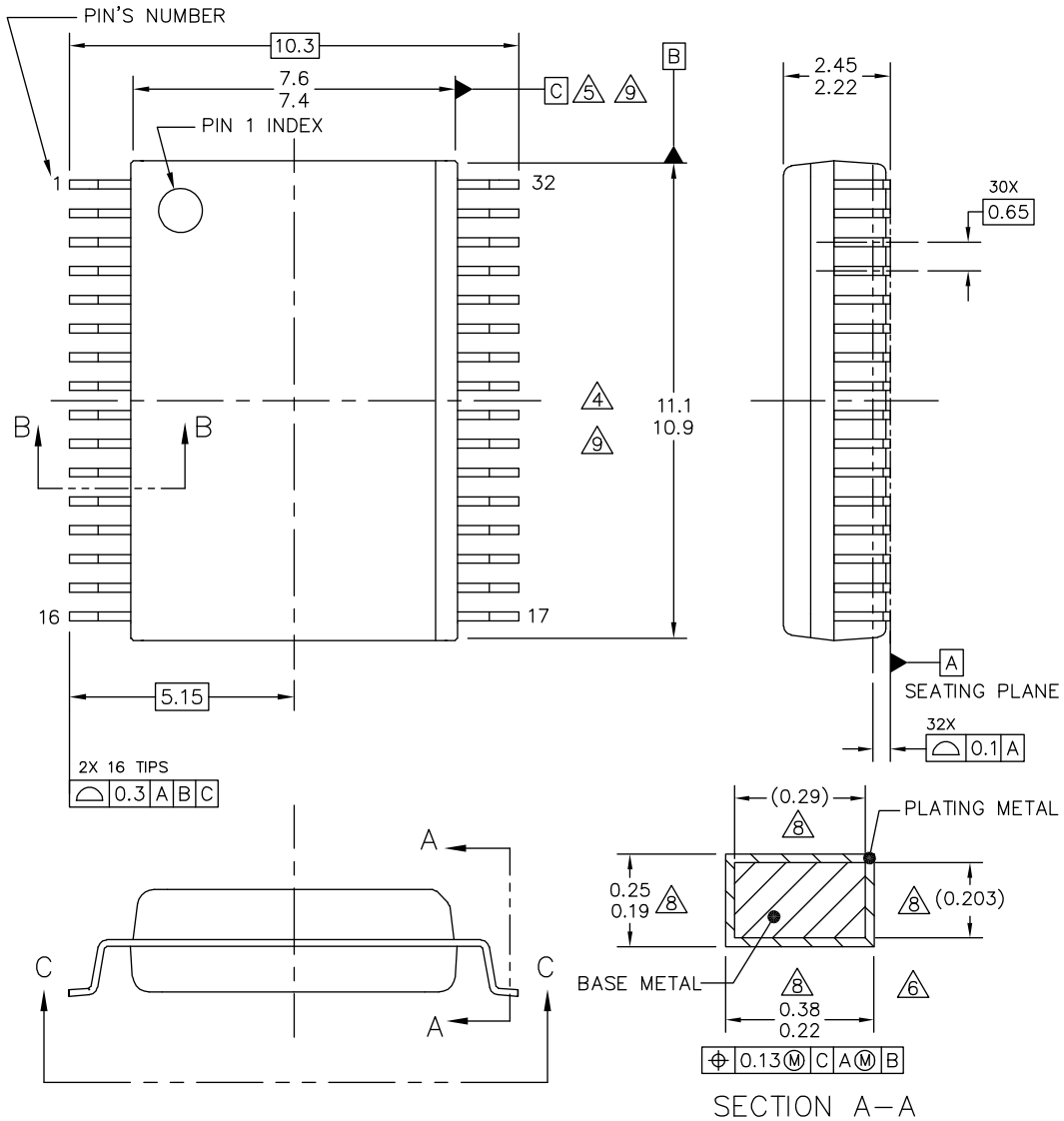

Figure 17. Power Supply Shutdown in Sleep Mode

PACKAGING

PACKAGE DIMENSIONS

Important: For the most current revision of the package, visit www.freescale.com and perform a “keyword” search on the “98A” number listed below.



© FREESCALE SEMICONDUCTOR, INC. ALL RIGHTS RESERVED.	MECHANICAL OUTLINE	PRINT VERSION NOT TO SCALE	
TITLE: 32LD SOIC W/B, 0.65 PITCH 4.7 X 4.7 EXPOSED PAD, CASE-OUTLINE	DOCUMENT NO: 98ASA10556D	REV: D	
	CASE NUMBER: 1454-04	20 JUN 2008	
	STANDARD: NON-JEDEC		

EK SUFFIX
32-PIN EXPOSED PAD
98ASA10556D
REVISION D

PACKAGE DIMENSIONS (Continued)

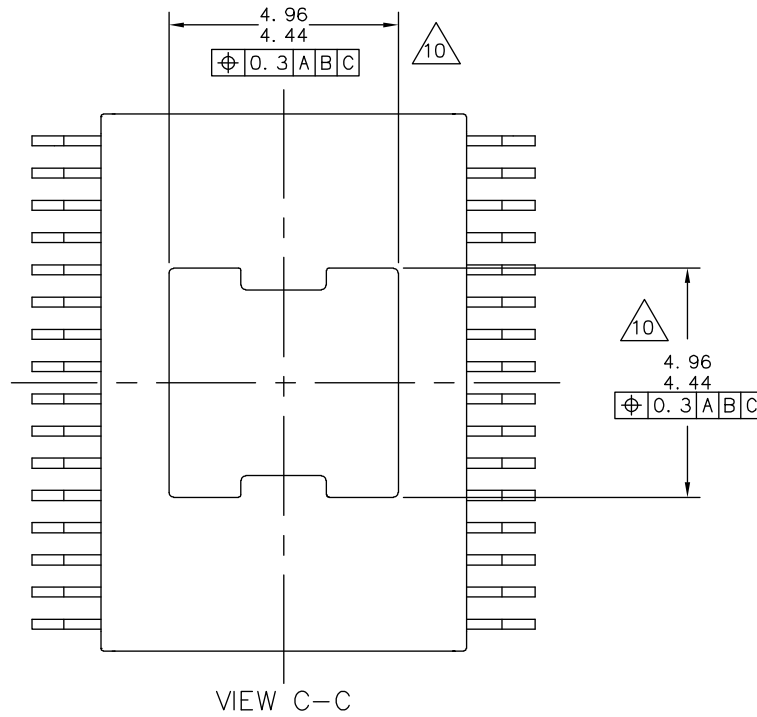
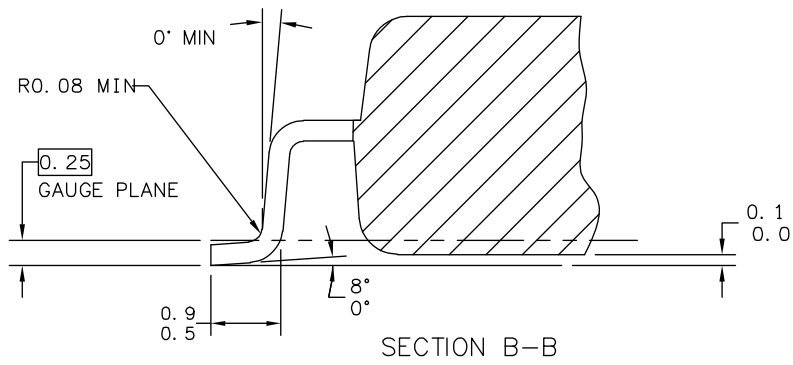

© FREESCALE SEMICONDUCTOR, INC. ALL RIGHTS RESERVED.	MECHANICAL OUTLINE	PRINT VERSION NOT TO SCALE	
TITLE: 32LD SOIC W/B, 0.65 PITCH 4.7 X 4.7 EXPOSED PAD, CASE-OUTLINE	DOCUMENT NO: 98ASA10556D	REV: D	
	CASE NUMBER: 1454-04	20 JUN 2008	
	STANDARD: NON-JEDEC		

EK SUFFIX
32-PIN EXPOSED PAD
98ASA10556D
REVISION D

NOTES:

1. DIMENSIONS ARE IN MILLIMETERS.
2. DIMENSIONING AND TOLERANCING PER ASME Y14.5M-1994.
3. DATUMS B AND C TO BE DETERMINED AT THE PLANE WHERE THE BOTTOM OF THE LEADS EXIT THE PLASTIC BODY.
4. THIS DIMENSION DOES NOT INCLUDE MOLD FLASH, PROTRUSION OR GATE BURRS. MOLD FLASH, PROTRUSION OR GATE BURRS SHALL NOT EXCEED 0.15 MM PER SIDE. THIS DIMENSION IS DETERMINED AT THE PLANE WHERE THE BOTTOM OF THE LEADS EXIT THE PLASTIC BODY.
5. THIS DIMENSION DOES NOT INCLUDE INTER-LEAD FLASH OR PROTRUSIONS. INTER-LEAD FLASH AND PROTRUSIONS SHALL NOT EXCEED 0.25 MM PER SIDE. THIS DIMENSION IS DETERMINED AT THE PLANE WHERE THE BOTTOM OF THE LEADS EXIT THE PLASTIC BODY.
6. THIS DIMENSION DOES NOT INCLUDE DAMBAR PROTRUSION. ALLOWABLE DAMBAR PROTRUSION SHALL NOT CAUSE THE LEAD WIDTH TO EXCEED 0.4 mm. DAMBAR CANNOT BE LOCATED ON THE LOWER RADIUS OR THE FOOT. MINIMUM SPACE BETWEEN PROTRUSION AND ADJACENT LEAD SHALL NOT LESS THAN 0.07 mm.
7. EXACT SHAPE OF EACH CORNER IS OPTIONAL.
8. THESE DIMENSIONS APPLY TO THE FLAT SECTION OF THE LEAD BETWEEN 0.10 mm AND 0.3 mm FROM THE LEAD TIP.
9. THE PACKAGE TOP MAY BE SMALLER THAN THE PACKAGE BOTTOM. THIS DIMENSION IS DETERMINED AT THE OUTERMOST EXTREMES OF THE PLASTIC BODY EXCLUSIVE OF MOLD FLASH, TIE BAR BURRS, GATE BURRS AND INTER-LEAD FLASH, BUT INCLUDING ANY MISMATCH BETWEEN THE TOP AND BOTTOM OF THE PLASTIC BODY.
10. THESE DIMENSION RANGES DEFINE THE PRIMARY KEEP-OUT AREA. MOLD LOCKING AND RESIN BLEED CONTROL FEATURES MAY BE VISIBLE AND THEY MAY EXTEND TO 0.34mm FROM MAXIMUM EXPOSED PAD SIZE

© FREESCALE SEMICONDUCTOR, INC. ALL RIGHTS RESERVED.	MECHANICAL OUTLINE	PRINT VERSION NOT TO SCALE	
TITLE: 32LD SOIC W/B, 0.65 PITCH 4.7 X 4.7 EXPOSED PAD, CASE-OUTLINE	DOCUMENT NO: 98ASA10556D	REV: D	
	CASE NUMBER: 1454-04	20 JUN 2008	
	STANDARD: NON-JEDEC		

EK SUFFIX
32-PIN EXPOSED PAD
98ASA10556D
REVISION D

REVISION HISTORY

Revision	Date	Description of Changes
5.0	6/2007	<ul style="list-style-type: none"> • Implemented Revision History page • Updated to Freescale form and style • Added MCZ33975EK/R2 and MCZ33975AEK/R2 • Removed Peak Package Reflow Temperature During Reflow, and added Peak Package Reflow Temperature During Reflow⁽⁵⁾, ⁽⁶⁾
6.0	11/2007	<ul style="list-style-type: none"> • Removed MC33975AEK/R2 from the Ordering Information • Replaced figures for 33975 Simplified Application Diagram, Power Supply Active in Sleep Mode, and Power Supply Shutdown in Sleep Mode. • Adjusted ESD voltages for Human Body Model⁽²⁾ and Applies to all non-input Pins. • Updated document form and style.
7.0	2/2008	<ul style="list-style-type: none"> • Minor changes to text
8.0	8/2008	<ul style="list-style-type: none"> • Updated package drawing
9.0	8/2008	<ul style="list-style-type: none"> • Revised wording of Features on Page 1 - No parameter /technical changes.
10.0	8/2011	<ul style="list-style-type: none"> • Revised Ordering Information table by adding part numbers MC33975TEK/R2 and MC33975ATEK/R2, and removing part numbers MC33975EK/R2, MCZ33975EK/R2 and MCZ33975AEK/R2. • Updated document form and style.
11.0	01/2014	<ul style="list-style-type: none"> • No technical changes. Revised back page. Updated document properties. Added SMARTMOS sentence to last paragraph.

How to Reach Us:

Home Page:
freescale.com

Web Support:
freescale.com/support

Information in this document is provided solely to enable system and software implementers to use Freescale products. There are no express or implied copyright licenses granted hereunder to design or fabricate any integrated circuits based on the information in this document.

Freescale reserves the right to make changes without further notice to any products herein. Freescale makes no warranty, representation, or guarantee regarding the suitability of its products for any particular purpose, nor does Freescale assume any liability arising out of the application or use of any product or circuit, and specifically disclaims any and all liability, including without limitation consequential or incidental damages. "Typical" parameters that may be provided in Freescale data sheets and/or specifications can and do vary in different applications, and actual performance may vary over time. All operating parameters, including "typicals," must be validated for each customer application by customer's technical experts. Freescale does not convey any license under its patent rights nor the rights of others. Freescale sells products pursuant to standard terms and conditions of sale, which can be found at the following address: freescale.com/SalesTermsandConditions.

Freescale and the Freescale logo are trademarks of Freescale Semiconductor, Inc., Reg. U.S. Pat. & Tm. Off. SMARTMOS is a trademark of Freescale Semiconductor, Inc. All other product or service names are the property of their respective owners.

© 2014 Freescale Semiconductor, Inc.

Document Number: MC33975
Rev 11.0
01/2014



Стандарт Электрон Связь

Мы молодая и активно развивающаяся компания в области поставок электронных компонентов. Мы поставляем электронные компоненты отечественного и импортного производства напрямую от производителей и с крупнейших складов мира.

Благодаря сотрудничеству с мировыми поставщиками мы осуществляем комплексные и плановые поставки широчайшего спектра электронных компонентов.

Собственная эффективная логистика и склад в обеспечивает надежную поставку продукции в точно указанные сроки по всей России.

Мы осуществляем техническую поддержку нашим клиентам и предпродажную проверку качества продукции. На все поставляемые продукты мы предоставляем гарантию .

Осуществляем поставки продукции под контролем ВП МО РФ на предприятия военно-промышленного комплекса России , а также работаем в рамках 275 ФЗ с открытием отдельных счетов в уполномоченном банке. Система менеджмента качества компании соответствует требованиям ГОСТ ISO 9001.

Минимальные сроки поставки, гибкие цены, неограниченный ассортимент и индивидуальный подход к клиентам являются основой для выстраивания долгосрочного и эффективного сотрудничества с предприятиями радиоэлектронной промышленности, предприятиями ВПК и научно-исследовательскими институтами России.

С нами вы становитесь еще успешнее!

Наши контакты:

Телефон: +7 812 627 14 35

Электронная почта: sales@st-electron.ru

Адрес: 198099, Санкт-Петербург,
Промышленная ул, дом № 19, литера Н,
помещение 100-Н Офис 331