

SY89200U



Ultra-Precision 1:8 LVDS Fanout Buffer with Three $\div 1/\div 2/\div 4$ Clock Divider Output Banks

General Description

The SY89200U is a 2.5V precision, high-speed, integrated clock divider and LVDS fanout buffer capable of handling clocks up to 1.5GHz. Optimized for communications applications, the three independently controlled output banks are phase matched and can be configured for pass through ($\div 1$), $\div 2$ or $\div 4$ divider ratios.

The differential input includes Micrel's unique, 3-pin input termination architecture that allows the user to interface to any differential signal path. The low-skew, low-jitter outputs are LVDS-compatible with extremely fast rise/fall times guaranteed to be less than 150ps.

The EN (enable) input guarantees that the $\div 1$, $\div 2$ and $\div 4$ outputs will start from the same state without any runt pulse after an asynchronous master rest (MR) is asserted. This is accomplished by enabling the outputs after a four-clock delay to allow the counters to synchronize.

The SY89200U is part of Micrel's Precision Edge[®] product family.

Datasheets and support documentation can be found on Micrel's web site at: www.micrel.com.

Functional Block Diagram

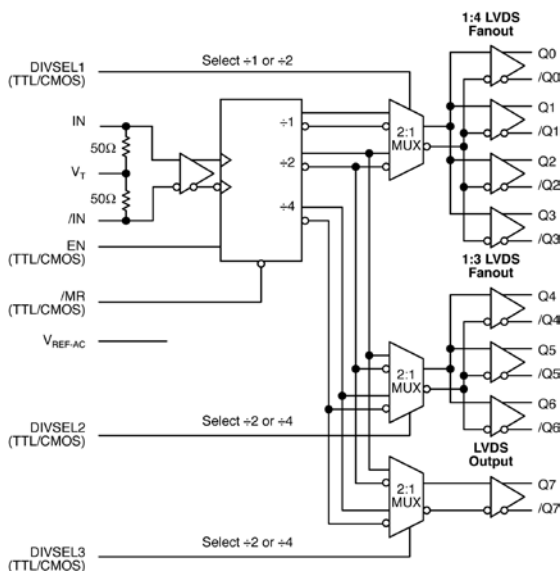

Precision Edge is a registered trademark of Micrel, Inc



Precision Edge[®]

Features

- Three low-skew LVDS output banks with programmable $\div 1$, $\div 2$ and $\div 4$ divider options
- Three independently programmable output banks
- Guaranteed AC performance over temperature and voltage:
 - Accepts a clock frequency up to 1.5GHz
 - <900ps IN-to-OUT propagation delay
 - <150ps rise/fall time
 - <50ps bank-to-bank phase offset
- Ultra-low jitter design:
 - <1ps_{RMS} random jitter
 - <10ps_{PP} total jitter (clock)
- Patent-pending input termination and VT pin accepts DC- and AC-coupled inputs (CML, PECL, LVDS)
- LVDS-compatible outputs
- CMOS/TTL-compatible output enable (EN) and divider select control
- 2.5V $\pm 5\%$ power supply
- -40°C to $+85^{\circ}\text{C}$ temperature range
- Available in 32-pin (5mm x 5mm) QFN package

Applications

- All SONET/SD applications
- All Fibre Channel applications
- All Gigabit Ethernet applications

Ordering Information⁽¹⁾

Part Number	Package Type	Temperature Range	Package Marking	Lead Finish
SY89200UMI	QFN-32	Industrial	SY89200U	Sn-Pb
SY89200UMITR ⁽²⁾	QFN-32	Industrial	SY89200U	Sn-Pb
SY89200UMG	QFN-32	Industrial	SY89200U with Pb-Free bar-line indicator	Pb-Free NiPdAu
SY89200UMGTR ⁽²⁾	QFN-32	Industrial	SY89200U with Pb-Free bar-line indicator	Pb-Free NiPdAu

Note:

1. Contact factory for die availability. Dice are guaranteed at TA = 25°C, DC Electricals only.
2. Tape and Reel.

Pin Configuration

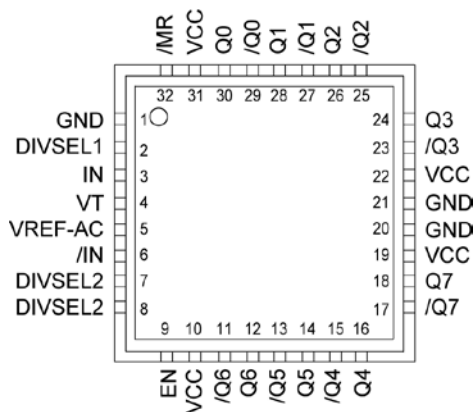

32-Pin QFN

Pin Description

Pin Number	Pin Name	Pin Function
3, 6	IN, /IN	Differential Input: This input pair is the differential signal input to the device. This input accepts AC- or DC-coupled signals as small as 100mV. The input pair internally terminates to a VT pin through 50Ω. Note that these inputs will default to an indeterminate state if left open. Please refer to the “Input Interface Applications” section for more details.
2 7 8	DIVSEL1 DIVSEL2 DIVSEL3	Single-Ended Inputs: These TTL/CMOS inputs select the device ratio for each of the three banks of outputs. Note that each of these inputs is internally connected to a 25k Ω pull-up resistor and will default to logic HIGH state if left open. The input-switching threshold is $V_{CC}/2$.
4	VT	Input Termination Center-Tap: Each side of the differential input pair terminates to the VT pin. The VT pin provides a center-tap to a termination network for maximum interface flexibility. See “Input Interface Applications” section for more details.
5	VREF-AC	Reference Voltage: This output biases to $V_{CC}-1.2V$. It is used for AC-coupling inputs IN and /IN. For AC-coupled applications, connect VREF-AC directly to the VT pin. Bypass with 0.01μF low ESR capacitor to V_{CC} . Maximum sink/source capability is 0.5mA.
9	EN	Single-Ended Input: This TTL/CMOS input disable and enable the Q0 – Q7 outputs. This input is internally connected to a 25kΩ pull-up resistor and will default to logic HIGH state if left open. The input-switching threshold is $V_{CC}/2$. For the input enable and disable functional description, refer to Figures 2a through 2c.
30, 29, 28, 27, 26, 25, 24, 23	Q0, /Q0, /Q1, /Q1, Q2, /Q2 Q3, /Q3	Bank 1 LVDS differential output pairs controlled by DIVSEL1: LOW Q0 – Q3 = ÷1 HIGH, Q0 – Q3 = ÷2. Unused output pairs should be terminated with 100Ω across the differential pair.
16, 15, 14, 13, 12, 11	Q4, /Q4, Q5, /Q5, Q6, /Q6	Bank 2 LVDS differential output pairs controlled by DIVSEL2: LOW Q4 – Q6 = ÷2 HIGH, Q4 – Q6 = ÷2. Unused output pairs should be terminated with 100Ω across the differential pair.
18, 17	Q7, /Q7	Bank 3 LVDS differential output pairs controlled by DIVSEL3: LOW Q7 = ÷2 HIGH, Q7 = ÷2. Unused output pairs should be terminated with 100Ω across the differential pair.
32	/MR	Single-Ended Input: This TTL/CMOS-compatible master reset function asynchronously sets Q0 – Q7 outputs LOW, /Q0 – /Q7 outputs HIGH, and holds them in that state as long as /MR remains LOW. This input is internally connected to a 25k Ω pull-up resistor and will default to a logic HIGH state if left open. The input-switching threshold is $V_{CC}/2$.
10, 19, 22, 31	VCC	Positive power supply. Bypass with 0.1μF 0.01μF low ESR capacitors.
1, 20, 21	GND Exposed	Ground and exposed pad must be connected to the same GND plane on the board.

Truth Table

/MR ⁽¹⁾	EN ^(2,3)	DIVSEL1	DIVSEL2	DIVSEL3	Q0 – Q3	Q4 – Q6	Q7
0	X	X	X	X	0	0	0
1	0	X	X	X	0	0	0
1	1	0	0	0	÷1	÷2	÷2
1	1	1	1	1	÷2	÷4	÷4

Notes:

1. /MR asynchronously forces Q0 – Q7 LOW (/Q0 – /Q7 HIGH).
2. EN forces Q0 – Q7 LOW between 2 and 6 input clock cycles after the falling edge of EN. Refer to “Timing Diagram” section.
3. EN synchronously enables the outputs between two and six input clock cycles after the rising edge of EN. Refer to “Timing Diagram” section.

Absolute Maximum Ratings⁽¹⁾

Supply Voltage (V_{CC}) -0.5V to +4.0V
 Input Voltage (V_{IN}) -0.5V to V_{CC}
 Termination Current⁽³⁾
 Source or sink current on V_T ± 100 mA
 Output Current⁽³⁾
 Source or sink current on IN, /IN ± 50 mA
 V_{REF-AC} Current⁽³⁾
 Source or sink current on V_{REF-AC} ± 2 mA
 Lead Temperature (soldering, 20 sec.) +260°C
 Storage Temperature (T_s) -65°C to +150°C

Operating Ratings⁽²⁾

Supply Voltage (V_{CC}) +2.375V to +2.625V
 Ambient Temperature (T_A) -40°C to +85°C
 Package Thermal Resistance⁽⁴⁾
 QFN (θ_{JA})
 Still-Air 35°C/W
 QFN (Ψ_{JB})
 Junction -to-Board 20°C/W

DC Electrical Characteristics

$T_A = -40^\circ\text{C}$ to $+85^\circ\text{C}$, unless otherwise stated.

Symbol	Parameter	Condition	Min	Typ	Max	Units
V_{CC}	Power Supply		2.375	2.5	2.625	V
I_{CC}	Power Supply Current	No load, max. V_{CC} , Note 6			350	mA
R_{DIFF_IN}	Differential Input Resistance (IN-to-/IN)		80	100	120	Ω
R_{IN}	Input Resistance (IN-to- V_T , /IN-to- V_T)		40	50	60	Ω
V_{IH}	Input High Voltage; (IN, /IN)		1.2		V_{CC}	V
V_{IL}	Input Low Voltage; (IN, /IN)		0		$V_{IH}-0.1$	V
V_{IN}	Input Voltage Swing; (IN, /IN)	See Figure 1a.	0.1		V_{CC}	V
V_{DIFF_IN}	Differential Input Voltage Swing IN - /IN	See Figure 1b.	0.2			V
V_{REF-AC}	Reference Voltage		$V_{CC}-1.3$	$V_{CC}-1.2$	$V_{CC}-1.1$	V
IN-to- V_T	Voltage from Input to V_T				1.8	V

LVTTTL/CMOS DC Electrical Characteristics⁽⁵⁾

$V_{CC} = 2.5V \pm 5\%$; $T_A = -40^\circ\text{C}$ to $+85^\circ\text{C}$, unless otherwise stated.

Symbol	Parameter	Condition	Min	Typ	Max	Units
V_{IH}	Input HIGH Voltage		2.0			V
V_{IL}	Input LOW Voltage				0.8	V
I_{IH}	Input HIGH Current		-125		30	μA
I_{IL}	Input Low Current				-300	μA

Notes:

1. Permanent device damage may occur if ratings in the "Absolute Maximum Ratings" section are exceeded. This is a stress rating only and functional operation is not implied for conditions other than those detailed in the operational sections of this datasheet. Exposure to absolute maximum ratings conditions for extended periods may affect device reliability.
2. The datasheet limits are not guaranteed if the device is operated beyond the operating ratings.
3. Due to the limited drive capability use for input of the same package only.
4. Package thermal resistance assumes exposed pad is soldered (or equivalent) to the device's most negative potential on the PCB. Ψ_{JB} uses 4-layer θ_{JA} in still-air, unless otherwise stated.
5. The circuit is designed to meet the DC specifications shown in the above table after thermal equilibrium has been established.
6. Includes current through internal 50 Ω pull-up.

LVDS OUTPUT DC Electrical Characteristics⁽⁷⁾

$V_{CC} = 2.5V \pm 5\%$; $T_A = -40^\circ C$ to $+85^\circ C$; $R_L = 100\Omega$ across Q and /Q, unless otherwise stated.

Symbol	Parameter	Condition	Min	Typ	Max	Units
V_{OH}	Output HIGH Voltage; (Q, /Q)				1.475	V
V_{OL}	Output LOW Voltage; (Q, /Q)		0.925			V
V_{OUT}	Output Voltage Swing; (Q, /Q)		250	350		mV
V_{DIFF_OUT}	Differential Output Voltage Swing Q - /Q		500	700		mV
V_{OCM}	Output Common Mode Voltage (Q, /Q)		1.125		1.275	V
ΔV_{OCM}	Change in Common Mode Voltage (Q, /Q)		-50		+50	mV

AC Electrical Characteristics⁽⁸⁾

$V_{CC} = 2.5V \pm 5\%$; $T_A = -40^\circ C$ to $+85^\circ C$; $R_L = 100\Omega$ across all outputs (Q and /Q), unless otherwise stated.

Symbol	Parameter	Condition	Min	Typ	Max	Units
f_{MAX}	Maximum Operating Frequency	$V_{OUT} > 200mV$ Clock	1.5			GHz
t_{PD}	Differential Propagation Delay	IN-to-Q	500	700	900	ps
		/MR-to-Q			900	ps
t_{RR}	Reset Recovery Time	/MR(L-H)-to-(L-H)			900	ps
t_{PD} Tempco	Differential Propagation Delay Temperature Coefficient			115		fs/ $^\circ C$
t_{SKEW}	Within-Bank Skew	Within same fanout bank, Note 9		10	25	ps
	Bank-to-Bank Skew	Same divide setting, Note 10		15	35	ps
	Bank-to-Bank Skew	Differential divide setting, Note 10		25	50	ps
	Part-to-Part Skew	Note 11			200	ps
t_{JITTER}	Random Jitter (RJ)	Note 12			1	pSRMS
	Total Jitter (TJ)	Note 13			10	pSPP
	Cycle-to-Cycle Jitter	Note 14			1	pSRMS
t_r, t_f	Rise/Fall Time	20% to 80% at full output swing	40	80	150	ps

Notes:

- The circuit is designed to meet the DC specifications shown in the above table after thermal equilibrium has been established.
- Measured with 100mV input swing. See "Timing Diagram" section for definition of parameters. High-frequency AC-parameters are guaranteed by design and characterization.
- Within-bank is the difference in propagation delays among the outputs within the same bank.
- Bank-to-bank skew is the difference in propagation delays between outputs from different banks. Bank-to-bank skew is also the phase offset between each bank after MR is applied.
- Part-to-part skew is defined for two parts with identical power supply voltages at the same temperature and with no skew of the edges at the respective inputs.
- RJ is measured with a K28.7 comma detect character pattern.
- Total jitter definition: with an ideal clock input of frequency $\leq f_{MAX}$, no more than one output edge in 10^{12} output edges will deviate by more than the specified peak-to-peak jitter value.
- Cycle-to-cycle jitter definition: the variation of periods between adjacent cycles, $T_n - T_{n-1}$ where T is the time between rising edges of the output signal.

Single-Ended Differential Swings



Figure 1a. Single-Ended Voltage Swing



Figure 1b. Differential Voltage Swing

Timing Diagram

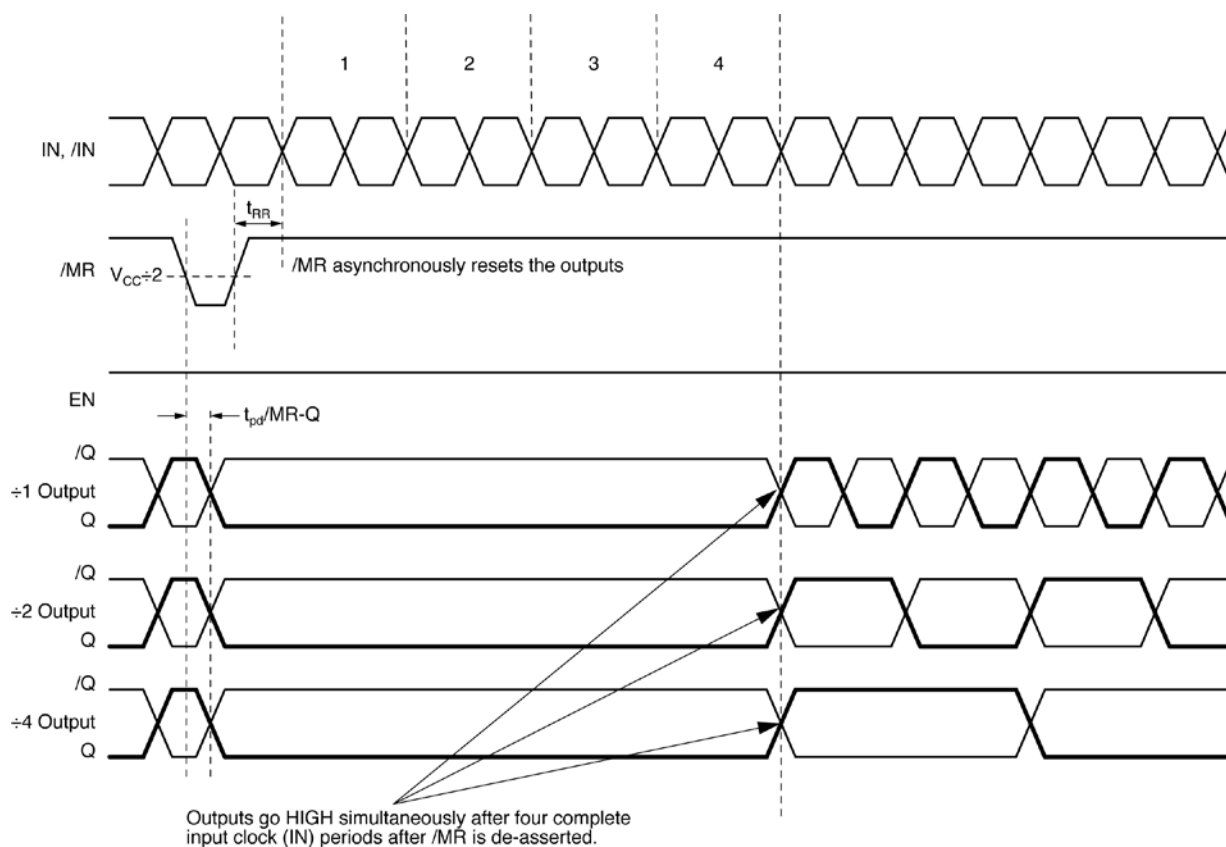

Figure 2a. Reset with Output Enabled

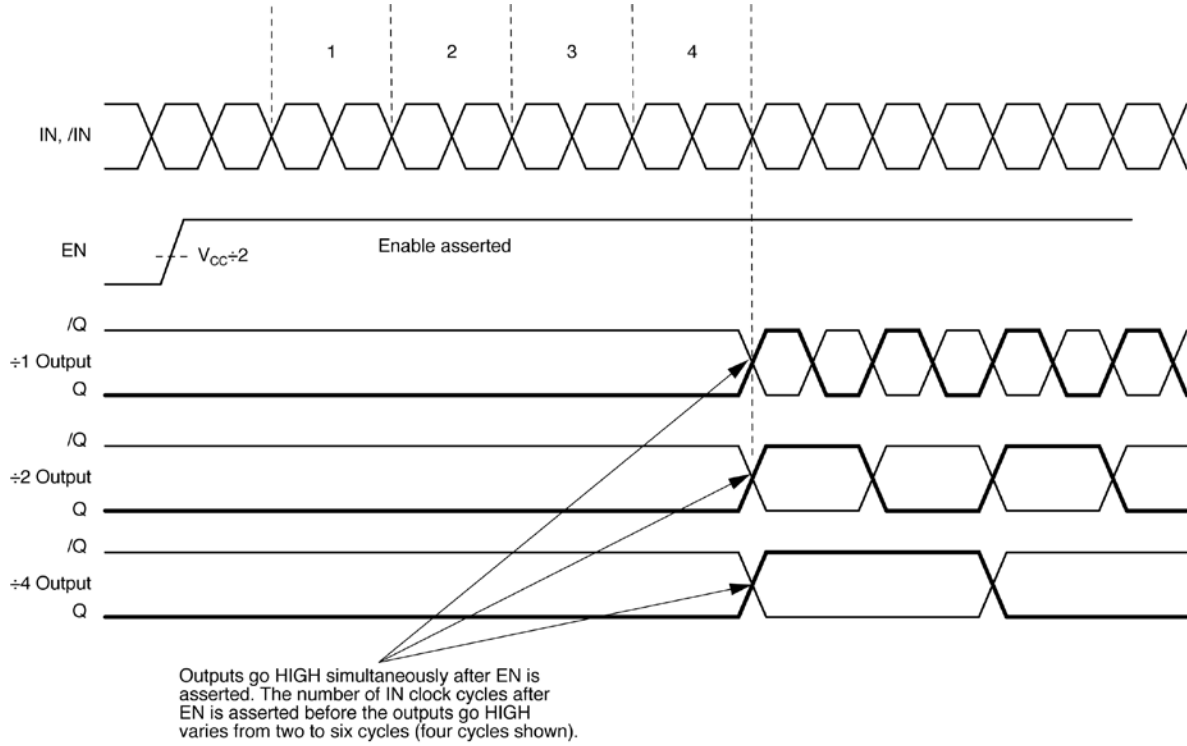

Figure 2b. Enable Timing

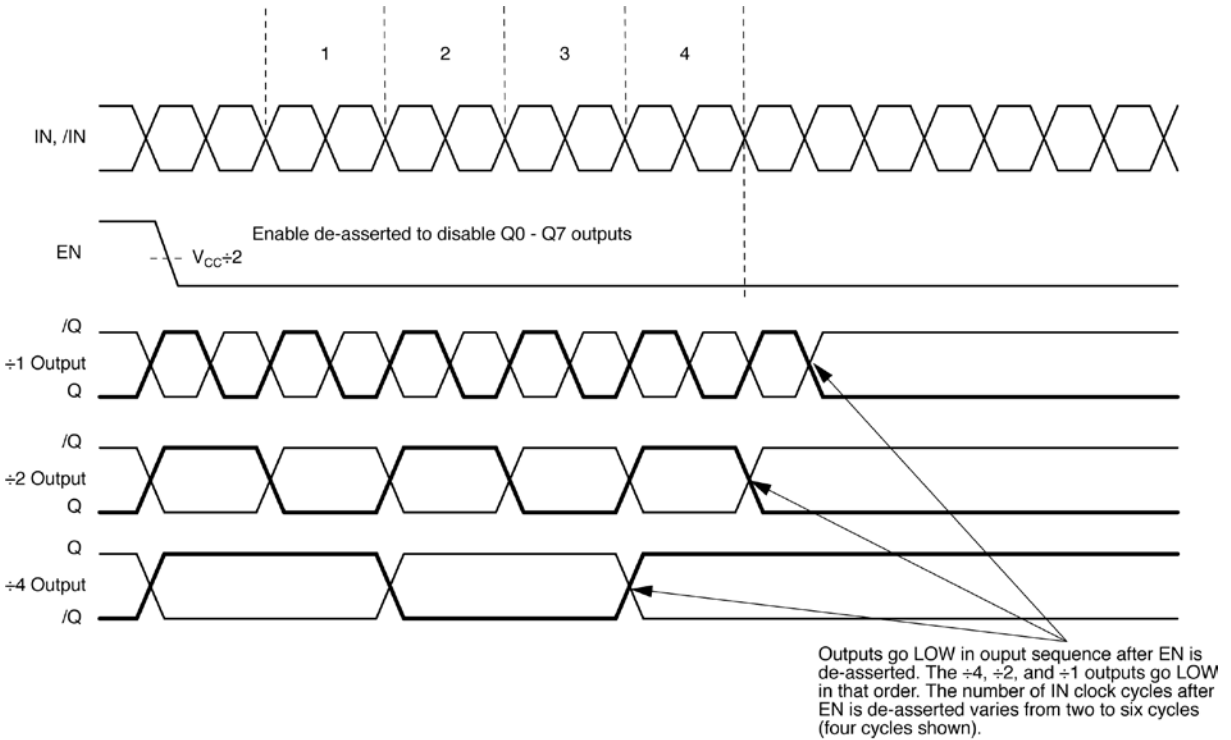
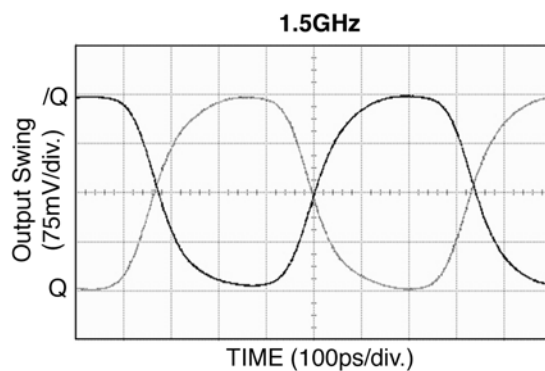
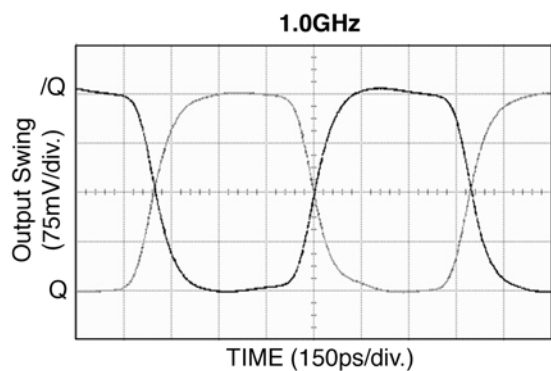
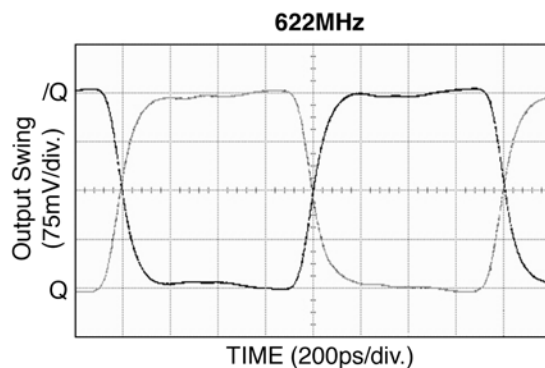
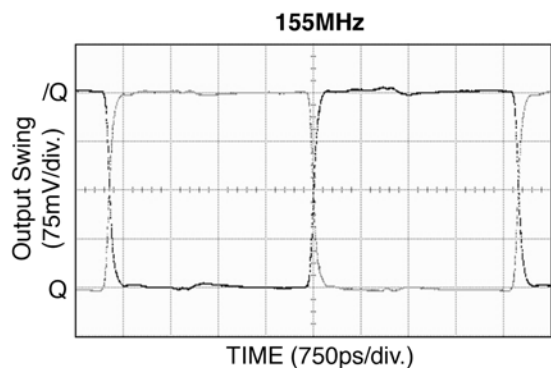

Figure 2c. Disable Timing

Typical Operating Characteristics



Input Stage Internal Termination

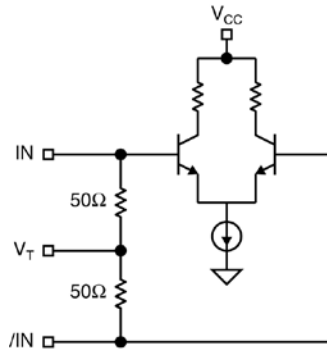

Figure 3. Simplified Differential Input Stage

Input Interface Applications

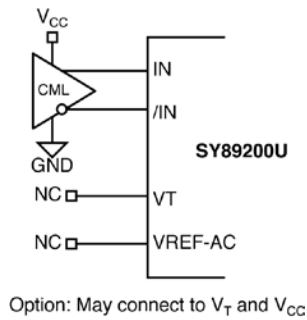

Figure 4a. CML Interface (DC-Coupled)

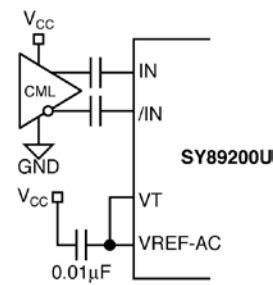

Figure 4b. CML Interface (AC-Coupled)

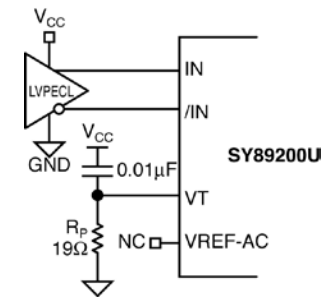

Figure 4c. LVPECL Interface (DC-Coupled)

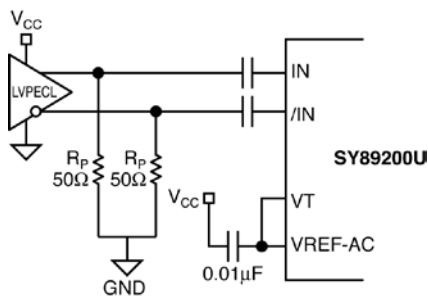

Figure 4d. LVPECL Interface (AC-Coupled)

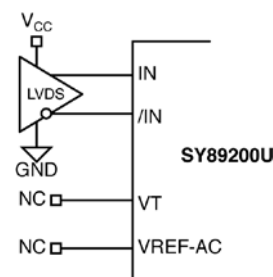

Figure 4e. LVDS Interface

Output Interface Applications

LVDS specifies a small swing of 350mV typical, on a nominal 1.25V common mode above ground. The common mode voltage has tight limits to permit large variations in ground between an LVDS driver and receiver. Also, change in common mode voltage, as a function of data input, is kept to a minimum to keep EMI low.

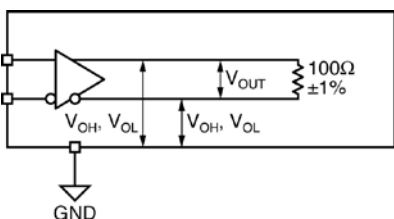

Figure 5a. LVDS Differential Measurement

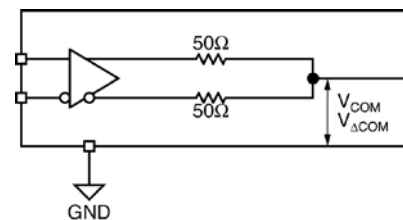
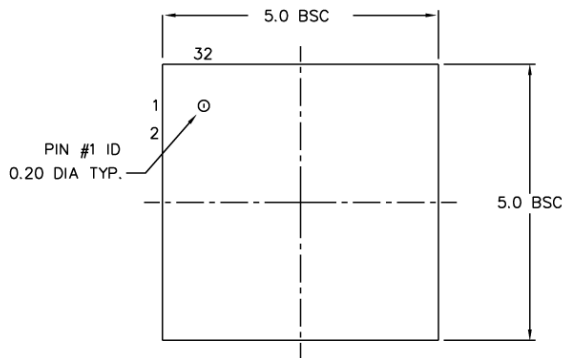

Figure 5b. LVDS Common Mode Measurement

Related Product and Support Documentation

Part Number	Function	Datasheet Link
HBW Solutions	New Products and Applications	www.micrel.com/product-info/products/solutions.shtml

Package Information



TOP VIEW

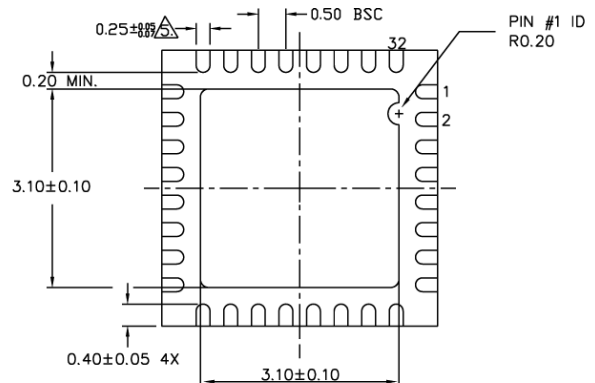

BOTTOM VIEW

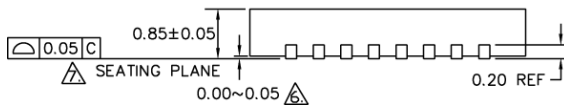

SIDE VIEW

NOTE:

1. ALL DIMENSIONS ARE IN MILLIMETERS.
2. MAX. PACKAGE WARPAGE IS 0.05 mm.
3. MAXIMUM ALLOWABLE BURRS IS 0.076 mm IN ALL DIRECTIONS.
4. PIN #1 ID ON TOP WILL BE LASER/INK MARKED.
- ④ DIMENSION APPLIES TO METALIZED TERMINAL AND IS MEASURED BETWEEN 0.20 AND 0.25 mm FROM TERMINAL TIP.
- ⑤ APPLIED ONLY FOR TERMINALS.
- ⑥ APPLIED FOR EXPOSED PAD AND TERMINALS.

32-Pin QFN

MICREL, INC. 2180 FORTUNE DRIVE SAN JOSE, CA 95131 USA
 TEL +1 (408) 944-0800 FAX +1 (408) 474-1000 WEB <http://www.micrel.com>

The information furnished by Micrel in this data sheet is believed to be accurate and reliable. However, no responsibility is assumed by Micrel for its use. Micrel reserves the right to change circuitry and specifications at any time without notification to the customer.

Micrel Products are not designed or authorized for use as components in life support appliances, devices or systems where malfunction of a product can reasonably be expected to result in personal injury. Life support devices or systems are devices or systems that (a) are intended for surgical implant into the body or (b) support or sustain life, and whose failure to perform can be reasonably expected to result in a significant injury to the user. A Purchaser's use or sale of Micrel Products for use in life support appliances, devices or systems is a Purchaser's own risk and Purchaser agrees to fully indemnify Micrel for any damages resulting from such use or sale.

© 2006 Micrel, Incorporated.



Стандарт Электрон Связь

Мы молодая и активно развивающаяся компания в области поставок электронных компонентов. Мы поставляем электронные компоненты отечественного и импортного производства напрямую от производителей и с крупнейших складов мира.

Благодаря сотрудничеству с мировыми поставщиками мы осуществляем комплексные и плановые поставки широчайшего спектра электронных компонентов.

Собственная эффективная логистика и склад в обеспечивает надежную поставку продукции в точно указанные сроки по всей России.

Мы осуществляем техническую поддержку нашим клиентам и предпродажную проверку качества продукции. На все поставляемые продукты мы предоставляем гарантию .

Осуществляем поставки продукции под контролем ВП МО РФ на предприятия военно-промышленного комплекса России , а также работаем в рамках 275 ФЗ с открытием отдельных счетов в уполномоченном банке. Система менеджмента качества компании соответствует требованиям ГОСТ ISO 9001.

Минимальные сроки поставки, гибкие цены, неограниченный ассортимент и индивидуальный подход к клиентам являются основой для выстраивания долгосрочного и эффективного сотрудничества с предприятиями радиоэлектронной промышленности, предприятиями ВПК и научно-исследовательскими институтами России.

С нами вы становитесь еще успешнее!

Наши контакты:

Телефон: +7 812 627 14 35

Электронная почта: sales@st-electron.ru

Адрес: 198099, Санкт-Петербург,
Промышленная ул, дом № 19, литера Н,
помещение 100-Н Офис 331