



SigmaDSP 28-/56-Bit Audio Processor with Two ADCs and Four DACs

ADAU1701

FEATURES

- 28-/56-bit, 50 MIPS digital audio processor**
- 2 ADCs: SNR of 100 dB, THD + N of -83 dB**
- 4 DACs: SNR of 104 dB, THD + N of -90 dB**
- Complete standalone operation**
- Self-boot from serial EEPROM**
- Auxiliary ADC with 4-input mux for analog control**
- GPIOs for digital controls and outputs**
- Fully programmable with SigmaStudio graphical tool**
- 28-bit × 28-bit multiplier with 56-bit accumulator for full double-precision processing**
- Clock oscillator for generating a master clock from crystal**
- PLL for generating master clock from $64 \times f_s$, $256 \times f_s$, $384 \times f_s$, or $512 \times f_s$ clocks**
- Flexible serial data input/output ports with I²S-compatible, left-justified, right-justified, and TDM modes**
- Sampling rates of up to 192 kHz are supported**
- On-chip voltage regulator for compatibility with 3.3 V systems**
- 48-lead, plastic LQFP**

APPLICATIONS

- Multimedia speaker systems**
- MP3 player speaker docks**
- Automotive head units**
- Minicomponent stereos**
- Digital televisions**
- Studio monitors**
- Speaker crossovers**
- Musical instrument effects processors**
- In-seat sound systems (aircraft/motor coaches)**

GENERAL DESCRIPTION

The ADAU1701 is a complete single-chip audio system with a 28-/56-bit audio DSP, ADCs, DACs, and microcontroller-like control interfaces. Signal processing includes equalization, cross-over, bass enhancement, multiband dynamics processing, delay compensation, speaker compensation, and stereo image widening. This processing can be used to compensate for real-world limitations of speakers, amplifiers, and listening environments, providing dramatic improvements in perceived audio quality.

Its signal processing is comparable to that found in high end studio equipment. Most processing is done in full 56-bit, double precision mode, resulting in very good low level signal performance. The ADAU1701 is a fully programmable DSP. The easy to use SigmaStudio™ software allows the user to graphically configure a custom signal processing flow using blocks such as biquad filters, dynamics processors, level controls, and GPIO interface controls.

ADAU1701 programs can be loaded on power-up either from a serial EEPROM through its own self-boot mechanism or from an external microcontroller. On power-down, the current state of the parameters can be written back to the EEPROM from the ADAU1701 to be recalled the next time the program is run.

Two Σ - Δ ADCs and four Σ - Δ DACs provide a 98.5 dB analog input to analog output dynamic. Each ADC has a THD + N of -83 dB, and each DAC has a THD + N of -90 dB. Digital input and output ports allow a glueless connection to additional ADCs and DACs. The ADAU1701 communicates through an I²C® bus or a 4-wire SPI port.

Rev. B

Information furnished by Analog Devices is believed to be accurate and reliable. However, no responsibility is assumed by Analog Devices for its use, nor for any infringements of patents or other rights of third parties that may result from its use. Specifications subject to change without notice. No license is granted by implication or otherwise under any patent or patent rights of Analog Devices. Trademarks and registered trademarks are the property of their respective owners.

One Technology Way, P.O. Box 9106, Norwood, MA 02062-9106, U.S.A.
Tel: 781.329.4700 www.analog.com
Fax: 781.461.3113 ©2007–2011 Analog Devices, Inc. All rights reserved.

IMPORTANT LINKS FOR THE ADAU1701*

Last content update 3/19/2013 6:33 PM.

Selection Table for SigmaDSP Audio Processors

HARDWARE & SOFTWARE



[Analog Audio Input, Class-D Output with the ADAU1701 SigmaDSP Codec, Low Power SSM2306 Class-D Amplifier, and ADP3336 LDO Regulator \(CN0162\)](#)



[ADAU1701 Evaluation Board](#)



[CAD Symbols & Footprints](#)



[SigmaStudio™ Graphical Development Tool](#)



[Firmware Loader for SigmaDSPs](#)

[ADAU1701 Sound Audio System Linux Driver](#)

RELATED DOCUMENTATION

[SigmaDSP® Audio Processors Overview](#)

[AN-951: Using Hardware Controls with SigmaDSP GPIO Pins](#)

[AN-1006: Using the EVAL-ADUSB2EBZ](#)

[AN-923: Designing a System Using the ADAU1701/ADAU1702 in Self-Boot Mode](#)

[Sigma Studio Overview Video](#)

[VisualDSP++ 5.0 Linker and Utilities Manual](#)

[UG-072: Evaluation Board User Guide for ADAU1401](#)

[RAQs index](#)

DESIGN COLLABORATION COMMUNITY



Collaborate online with the ADI support team and other designers about select ADI products.



Follow us on Twitter: www.twitter.com/ADI_News

DESIGN SUPPORT

Submit your support request here:

[Linear and Data Converters](#)

[Embedded Processing and DSP](#)

Telephone our Customer Interaction Centers toll free:

Americas: 1-800-262-5643

Europe: 00800-266-822-82

China: 4006-100-006

India: 1800-419-0108

Russia: 8-800-555-45-90

[Quality and Reliability](#)

[Lead\(Pb\)-Free Data](#)

PURCHASING & CONTACT INFORMATION

ADAU1701

[View Price & Packaging](#)

[Request Evaluation Board](#)

[Request Samples](#)

[Check Inventory & Purchase](#)

[Find Local Distributors](#)

*This page was dynamically generated by Analog Devices, Inc. and inserted into this data sheet.

Note: Dynamic changes to the content on this page (labeled 'important links') does not constitute a change to the revision number of the product data sheet.

This content may be frequently modified.

TABLE OF CONTENTS

Features	1	RAMs and Registers	30
Applications	1	Address Maps	30
General Description	1	Parameter RAM	30
Revision History	3	Data RAM	30
Functional Block Diagram	4	Read/Write Data Formats	30
Specifications	5	Control Register Map	32
Analog Performance	5	Control Register Details	34
Digital Input/Output	6	2048 to 2055 (0x0800 to 0x0807)—Interface Registers	34
Power	6	2056 (0x0808)—GPIO Pin Setting Register	35
Temperature Range	6	2057 to 2060 (0x0809 to 0x080C)—Auxiliary ADC Data Registers	36
PLL and Oscillator	6	2064 to 2068 (0x0810 to 0x0814)—Safeload Data Registers	37
Regulator	7	2069 to 2073 (0x0815 to 0x819)—Safeload Address Registers	37
Digital Timing Specifications	7	2074 to 2075 (0x081A to 0x081B)—Data Capture Registers	38
Absolute Maximum Ratings	10	2076 (0x081C)—DSP Core Control Register	39
Thermal Resistance	10	2078 (0x081E)—Serial Output Control Register	40
ESD Caution	10	2079 (0x081F)—Serial Input Control Register	41
Pin Configuration and Function Descriptions	11	2080 to 2081 (0x0820 to 0x0821)—Multipurpose Pin Configuration Registers	42
Typical Performance Characteristics	14	2082 (0x0822)—Auxiliary ADC and Power Control	43
System Block Diagram	15	2084 (0x0824)—Auxiliary ADC Enable	43
Theory of Operation	16	2086 (0x0826)—Oscillator Power-Down	43
Initialization	17	2087 (0x0827)—DAC Setup	44
Power-Up Sequence	17	Multipurpose Pins	45
Control Registers Setup	17	Auxiliary ADC	45
Recommended Program/Parameter Loading Procedure	17	General-Purpose Input/Output Pins	45
Power Reduction Modes	17	Serial Data Input/Output Ports	45
Using the Oscillator	18	Layout Recommendations	48
Setting Master Clock/PLL Mode	18	Parts Placement	48
Voltage Regulator	19	Grounding	48
Audio ADCs	20	Typical Application Schematics	49
Audio DACs	21	Self-Boot Mode	49
Control Ports	22	I ² C Control	50
I ² C Port	23	SPI Control	51
SPI Port	26	Outline Dimensions	52
Self-Boot	27	Ordering Guide	52
Signal Processing	29		
Numeric Formats	29		
Programming	29		

REVISION HISTORY

6/11—Rev. A to Rev. B

Deleted Table 2; Renumbered Sequentially6
 Changes to Table 46

2/11—Rev. 0 to Rev. A

Moved Figure 14
 Changes to Specifications Section.....5
 Changes to Table 8, Test Conditions/Comments Column8
 Reordered Figures in Digital Timing Diagrams Section9
 Changes to Figure 2.....9
 Changes to Figure 5 and Figure 6.....10
 Changes to Table 1112
 Replaced Figure 8 to Figure 1115
 Renamed Theory of Operation Section17
 Changes to Initialization Section18
 Change to Setting the Master Clock/PLL Mode Section19
 Changes to Table 1523
 Replaced Figure 22 through Figure 2526
 Changes to EEPROM Format Section.....28
 Deleted Table 20, Renumbered Sequentially29
 Inserted Figure 28, Renumbered Sequentially29
 Changes to Control Register Details Section.....35
 Changes to Ordering Guide.....53

7/07—Revision 0: Initial Version

ADAU1701

FUNCTIONAL BLOCK DIAGRAM

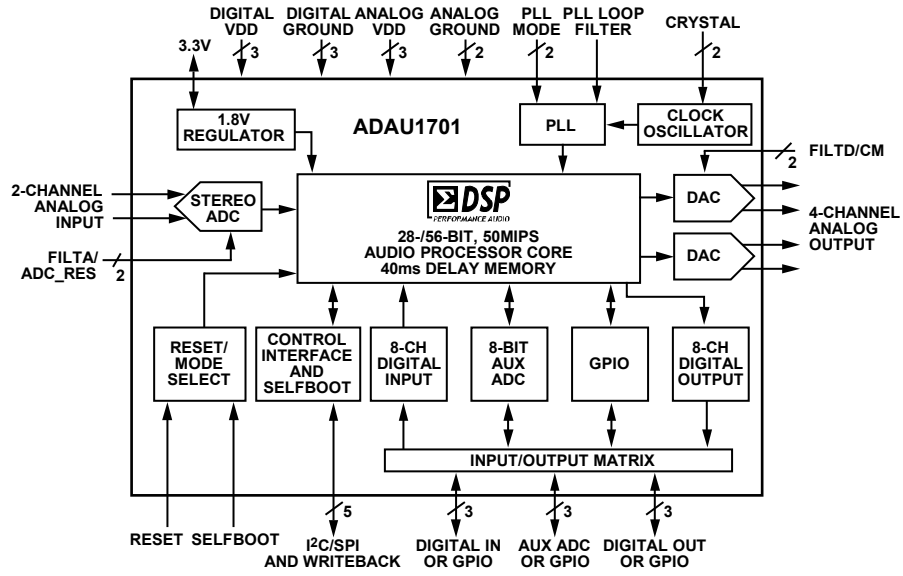

Figure 1.

06412-001

SPECIFICATIONS

AVDD = 3.3 V, DVDD = 1.8 V, PVDD = 3.3 V, IOVDD = 3.3 V, master clock input = 12.288 MHz, unless otherwise noted.

ANALOG PERFORMANCE

Specifications are guaranteed at 25°C (ambient).

Table 1.

Parameter	Min	Typ	Max	Unit	Test Conditions/Comments
ADC INPUTS					
Number of Channels		2			Stereo input
Resolution		24		Bits	
Full-Scale Input		100 (283)		μA rms (μA p-p)	2 V rms input with 20 kΩ (18 kΩ external + 2 kΩ internal) series resistor
Signal-to-Noise Ratio					
A-Weighted		100		dB	
Dynamic Range					–60 dB with respect to full-scale analog input
A-Weighted	95	100		dB	
Total Harmonic Distortion + Noise		–83		dB	–3 dB with respect to full-scale analog input
Interchannel Gain Mismatch		25	250	mdB	
Crosstalk		–82		dB	Analog channel-to-channel crosstalk
DC Bias	1.4	1.5	1.6	V	
Gain Error	–11		+11	%	
DAC OUTPUTS					
Number of Channels		4			Two stereo output channels
Resolution		24		Bits	
Full-Scale Analog Output		0.9 (2.5)		V rms (V p-p)	
Signal-to-Noise Ratio					
A-Weighted		104		dB	
Dynamic Range					–60 dB with respect to full-scale analog output
A-Weighted	99	104		dB	
Total Harmonic Distortion + Noise		–90		dB	–1 dB with respect to full-scale analog output
Crosstalk		–100		dB	Analog channel-to-channel crosstalk
Interchannel Gain Mismatch		25	250	mdB	
Gain Error	–10		+10	%	
DC Bias	1.4	1.5	1.6	V	
VOLTAGE REFERENCE					
Absolute Voltage (CM)	1.4	1.5	1.6	V	
AUXILIARY ADC					
Full-Scale Analog Input	2.8	3.0	3.1	V	
INL		0.5		LSB	
DNL		1.0		LSB	
Offset		15		mV	
Input Impedance	17.8	30	42	kΩ	

ADAU1701

DIGITAL INPUT/OUTPUT

Table 2.

Parameter	Symbol	Min	Typ	Max ¹	Unit	Test Conditions/Comments
Input Voltage, High	V _{IH}	2.0		IOVDD	V	
Input Voltage, Low	V _{IL}			0.8	V	
Input Leakage, High	I _{IH}			1	μA	Excluding MCLKI
Input Leakage, Low	I _{IL}			1	μA	Excluding MCLKI and bidirectional pins
Bidirectional Pin Pull-Up Current, Low				150	μA	
MCLKI Input Leakage, High	I _{IH}			3	μA	
MCLKI Input Leakage, Low	I _{IL}			3	μA	
High Level Output Voltage	V _{OH}	2.0			V	I _{OH} = 2 mA
Low Level Output Voltage	V _{OL}			0.8	V	I _{OL} = 2 mA
Input Capacitance				5	pF	
GPIO Output Drive			2		mA	

¹ Maximum specifications are measured across a temperature range of -40°C to +130°C (case), a DVDD range of 1.62 V to 1.98 V, and an AVDD range of 2.97 V to 3.63 V.

POWER

Table 3.

Parameter	Min	Typ	Max ¹	Unit
SUPPLY VOLTAGE				
Analog Voltage		3.3		V
Digital Voltage		1.8		V
PLL Voltage		3.3		V
IOVDD Voltage		3.3		V
SUPPLY CURRENT				
Analog Current (AVDD and PVDD)		50	85	mA
Digital Current (DVDD)		40	60	mA
Analog Current, Reset		35	55	mA
Digital Current, Reset		1.5	4.5	mA
DISSIPATION				
Operation (AVDD, DVDD, PVDD) ²		286.5		mW
Reset, All Supplies		118		mW
POWER SUPPLY REJECTION RATIO (PSRR)				
1 kHz, 200 mV p-p Signal at AVDD		50		dB

¹ Maximum specifications are measured across a temperature range of -40°C to +130°C (case), a DVDD range of 1.62 V to 1.98 V, and an AVDD range of 2.97 V to 3.63 V.

² Power dissipation does not include IOVDD power because the current drawn from this supply is dependent on the loads at the digital output pins.

TEMPERATURE RANGE

Table 4.

Parameter	Min	Typ	Max	Unit
Functionality Guaranteed	0		70	°C ambient

PLL AND OSCILLATOR

Table 5. PLL and Oscillator¹

Parameter	Min	Typ	Max	Unit
PLL Operating Range	MCLK_Nom - 20%		MCLK_Nom + 20%	MHz
PLL Lock Time			20	ms
Crystal Oscillator Transconductance (g _m)		78		mmho

¹ Maximum specifications are measured across a temperature range of -40°C to +130°C (case), a DVDD range of 1.62 V to 1.98 V, and an AVDD range of 2.97 V to 3.63 V.

REGULATOR

Table 6. Regulator¹

Parameter	Min	Typ	Max	Unit
DVDD Voltage	1.7	1.8	1.84	V

¹ Regulator specifications are calculated using a Zetex Semiconductors FZT953 transistor in the circuit.

DIGITAL TIMING SPECIFICATIONS

Table 7. Digital Timing¹

Parameter	Limit		Unit	Test Conditions/Comments
	t _{MIN}	t _{MAX}		
MASTER CLOCK				
t _{MP}	36	244	ns	MCLKI period, 512 × f _S mode
	48	366	ns	MCLKI period, 384 × f _S mode
	73	488	ns	MCLKI period, 256 × f _S mode
	291	1953	ns	MCLKI period, 64 × f _S mode
SERIAL PORT				
t _{BIL}	40		ns	INPUT_BCLK (Pin 9) low pulse width
t _{BIH}	40		ns	INPUT_BCLK (Pin 9) high pulse width
t _{LIS}	10		ns	INPUT_LRCLK (Pin 8) setup; time to INPUT_BCLK rising
t _{LIH}	10		ns	INPUT_LRCLK (Pin 8) hold; time from INPUT_BCLK rising
t _{SIS}	10		ns	SDATA_INx (Pin 10, Pin 11, Pin 28, or Pin 29) setup; time to INPUT_BCLK (Pin 9) rising
t _{SIH}	10		ns	SDATA_INx (Pin 10, Pin 11, Pin 28, or Pin 29) hold; time from INPUT_BCLK (Pin 9) rising
t _{LOS}	10		ns	OUTPUT_LRCLK (Pin 16) setup in slave mode
t _{LOH}	10		ns	OUTPUT_LRCLK (Pin 16) hold in slave mode
t _{TS}		5	ns	OUTPUT_BCLK (Pin 11) falling to OUTPUT_LRCLK (Pin 16) timing skew
t _{SODS}		40	ns	SDATA_OUTx (Pin 14, Pin 15, Pin 26, or Pin 27) delay in slave mode; time from OUTPUT_BCLK (Pin 11) falling
t _{SODM}		40	ns	SDATA_OUTx (Pin 14, Pin 15, Pin 26, or Pin 27) delay in master mode; time from OUTPUT_BCLK (Pin 11) falling
SPI PORT				
f _{CCLK}		6.25	MHz	CCLK (Pin 23) frequency
t _{CCPL}	80		ns	CCLK (Pin 23) pulse width low
t _{CCPH}	80		ns	CCLK (Pin 23) pulse width high
t _{CLS}	0		ns	CLATCH (Pin 21) setup; time to CCLK (Pin 23) rising
t _{CLH}	100		ns	CLATCH (Pin 21) hold; time from CCLK (Pin 23) rising
t _{CLPH}	80		ns	CLATCH (Pin 21) pulse width high
t _{CDS}	0		ns	CDATA (Pin 20) setup; time to CCLK (Pin 23) rising
t _{CDH}	80		ns	CDATA (Pin 20) hold; time from CCLK (Pin 23) rising
t _{COD}		101	ns	COUT (Pin 22) delay; time from CCLK (Pin 23) falling
I²C PORT				
f _{SCL}		400	kHz	SCL (Pin 23) frequency
t _{SCLH}	0.6		μs	SCL (Pin 23) high
t _{SCLL}	1.3		μs	SCL (Pin 23) low
t _{SCS}	0.6		μs	Setup time, relevant for repeated start condition
t _{SCH}	0.6		μs	Hold time; after this period, the first clock is generated
t _{DS}	100		ns	Data setup time
t _{SCR}		300	ns	SCL (Pin 23) rise time
t _{SCF}		300	ns	SCL (Pin 23) fall time
t _{SDR}		300	ns	SDA (Pin 22) rise time
t _{SDF}		300	ns	SDA (Pin 22) fall time
t _{BFT}	0.6			Bus-free time; time between stop and start

ADAU1701

Parameter	Limit		Unit	Test Conditions/Comments
	t_{MIN}	t_{MAX}		
MULTIPURPOSE PINS AND RESET				
t_{GRT}		50	ns	GPIO (MPx pins) rise time
t_{GFT}		50	ns	GPIO (MPx pins) fall time
t_{GIL}		$1.5 \times 1/f_s$	μs	GPIO (MPx pins) input latency; time until high/low value is read by core
t_{RLPW}	20		ns	RESET low pulse width

¹ All timing specifications are given for the default (I²S) states of the serial input port and the serial output port (see Table 65).

Digital Timing Diagrams

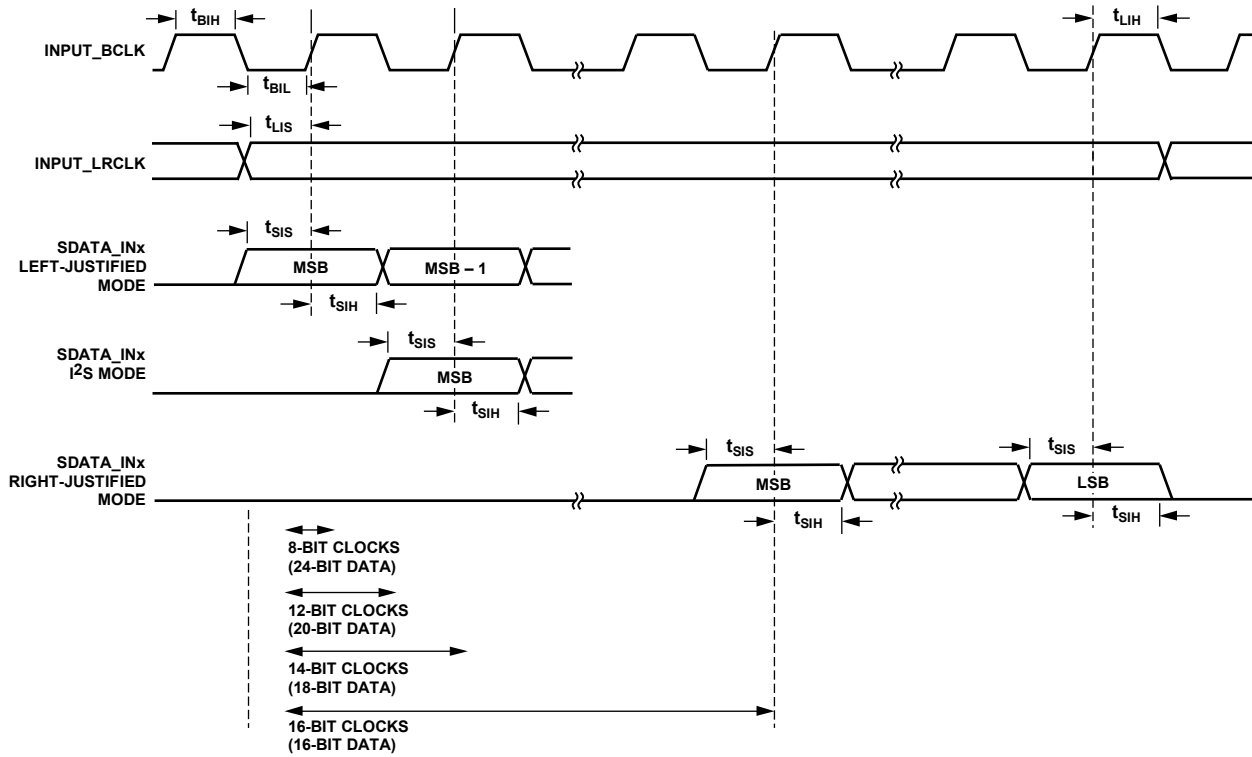

Figure 2. Serial Input Port Timing

06412-002

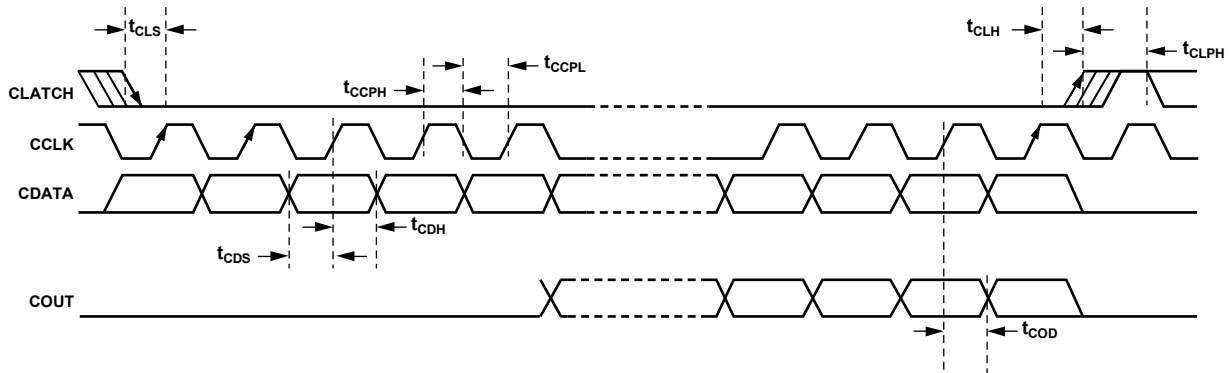

Figure 3. SPI Port Timing

06412-004

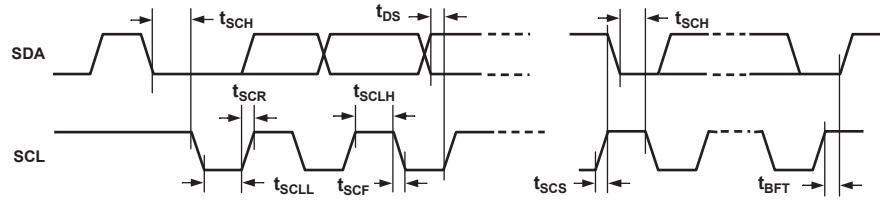

Figure 4. I²C Port Timing

06412-005

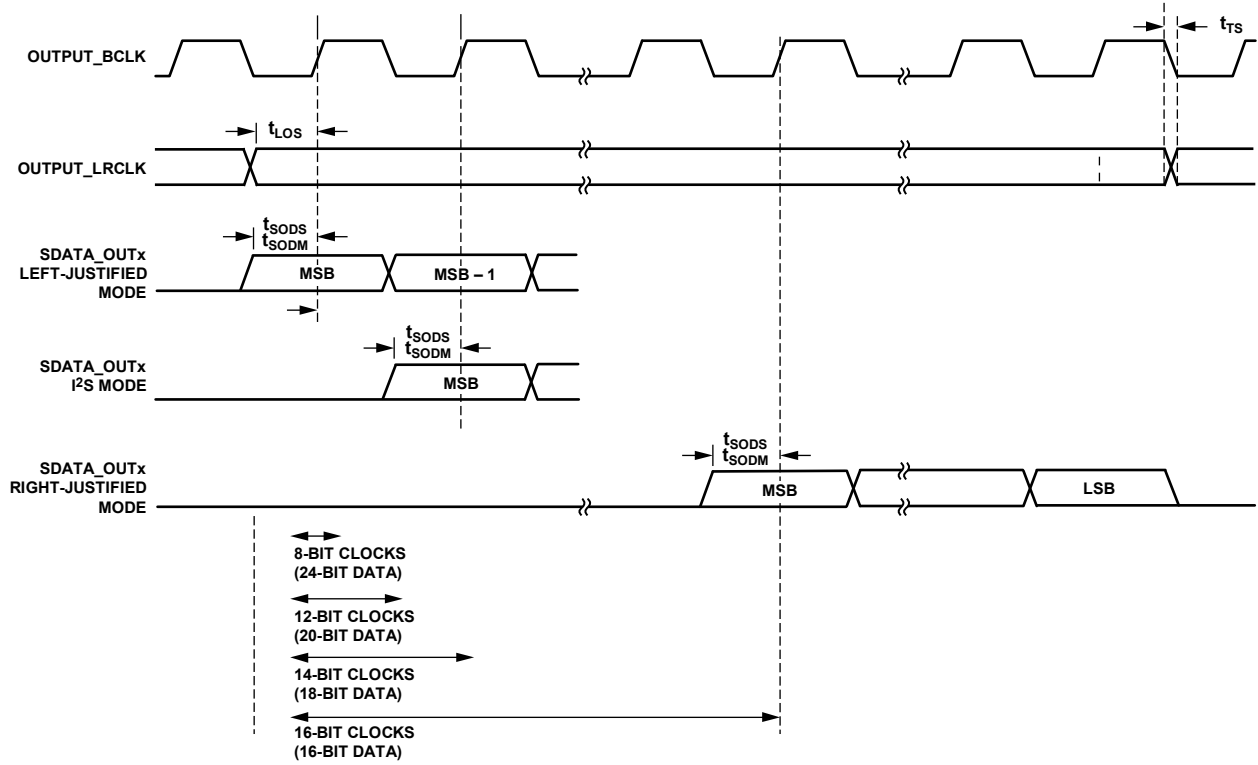

Figure 5. Serial Output Port Timing

06412-003

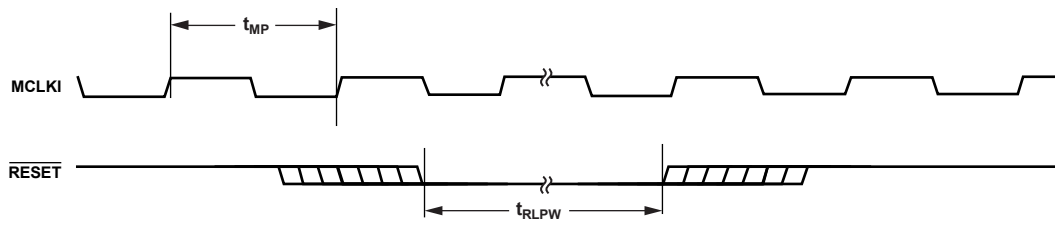

Figure 6. Master Clock and RESET Timing

06412-008

ABSOLUTE MAXIMUM RATINGS

Table 8.

Parameter	Rating
DVDD to GND	0 V to 2.2 V
AVDD to GND	0 V to 4.0 V
IOVDD to GND	0 V to 4.0 V
Digital Inputs	DGND – 0.3 V, IOVDD + 0.3 V
Maximum Junction Temperature	135°C
Temperature Range	
Storage	–65°C to +150°C
Operating	0°C to +70°C
Soldering (10 sec)	300°C

Stresses above those listed under Absolute Maximum Ratings may cause permanent damage to the device. This is a stress rating only; functional operation of the device at these or any other conditions above those indicated in the operational section of this specification is not implied. Exposure to absolute maximum rating conditions for extended periods may affect device reliability.

THERMAL RESISTANCE

θ_{JA} is specified for the worst-case conditions, that is, a device soldered in a circuit board for surface-mount packages.

Table 9. Thermal Resistance

Package Type	θ_{JA}	θ_{JC}	Unit
48-Lead LQFP	72	19.5	°C/W

ESD CAUTION



ESD (electrostatic discharge) sensitive device. Charged devices and circuit boards can discharge without detection. Although this product features patented or proprietary protection circuitry, damage may occur on devices subjected to high energy ESD. Therefore, proper ESD precautions should be taken to avoid performance degradation or loss of functionality.

PIN CONFIGURATION AND FUNCTION DESCRIPTIONS

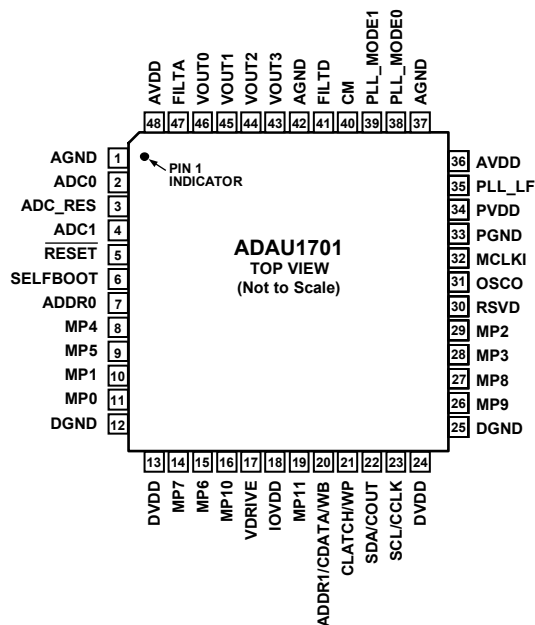

Figure 7. 48-Lead LQFP Pin Configuration

06412-007

Table 10. Pin Function Descriptions

Pin No.	Mnemonic	Type ¹	Description
1, 37, 42	AGND	PWR	Analog Ground Pin. The AGND, DGND, and PGND pins can be tied directly together in a common ground plane. Decouple AGND to an AVDD pin with a 100 nF capacitor.
2	ADC0	A_IN	Analog Audio Input 0. Full-scale 100 μ A rms input. Current input allows input voltage level to be scaled with an external resistor. An 18 k Ω resistor gives a 2 V rms full-scale input. See the Audio ADCs section for details.
3	ADC_RES	A_IN	ADC Reference Current. Set the full-scale current of the ADCs with an external 18 k Ω resistor connected between this pin and ground. See the Audio ADCs section for details.
4	ADC1	A_IN	Analog Audio Input 1. Full-scale 100 μ A rms input. Current input allows the input voltage level to be scaled with an external resistor. An 18 k Ω resistor gives a 2 V rms full-scale input.
5	RESET	D_IN	Active Low Reset Input. Reset is triggered on a high-to-low edge, and the ADAU1701 exits reset on a low-to-high edge. For more information about initialization, see the Power-Up Sequence section for details.
6	SELFBOOT	D_IN	Enable/Disable Self-Boot. SELFBOOT selects control port (low) or self-boot (high). Setting this pin high initiates a self-boot operation when the ADAU1701 is brought out of a reset. This pin can be tied directly to the control voltage or pulled up/down with a resistor. See the Self-Boot section for details.
7	ADDR0	D_IN	I ² C and SPI Address 0. In combination with ADDR1 function on Pin 20, this pin allows up to four ADAU1701 devices to be used on the same I ² C bus and up to two ICs to be used with a common SPI CLATCH signal. See the I ² C Port section for details.
8	MP4	D_IO	Multipurpose GPIO or Serial Input Port LRCLK (INPUT_LRCLK). See the Multipurpose Pins section for more details.
9	MP5	D_IO	Multipurpose GPIO or Serial Input Port BCLK (INPUT_BCLK). See the Multipurpose Pins section for more details.
10	MP1	D_IO	Multipurpose GPIO or Serial Input Port Data 1 (SDATA_IN0). See the Multipurpose Pins section for more details.
11	MP0	D_IO	Multipurpose GPIO or Serial Input Port Data 0 (SDATA_IN1). See the Multipurpose Pins section for more details.
12, 25	DGND	PWR	Digital Ground Pin. The AGND, DGND, and PGND pins can be tied directly together in a common ground plane. Decouple DGND to a DVDD pin with a 100 nF capacitor.
13, 24	DVDD	PWR	1.8 V Digital Supply. This can be supplied either externally or generated from a 3.3 V supply with the on-board 1.8 V regulator. Decouple DVDD to DGND with a 100 nF capacitor.

ADAU1701

Pin No.	Mnemonic	Type ¹	Description
14	MP7	D_IO	Multipurpose GPIO or Serial Output Port Data 1 (SDATA_OUT1). See the Multipurpose Pins section for more details.
15	MP6	D_IO	Multipurpose GPIO, Serial Output Port Data 0, or TDM Data Output (SDATA_OUT0). See the Multipurpose Pins section for more details.
16	MP10	D_IO	Multipurpose GPIO or Serial Output Port LRCLK (OUTPUT_LRCLK). See the Multipurpose Pins section for more details.
17	VDRIVE	A_OUT	Drive for 1.8 V Regulator. The base of the voltage regulator external PNP transistor is driven from VDRIVE. See the Voltage Regulator section for details.
18	IOVDD	PWR	Supply for Input and Output Pins. The voltage on this pin sets the highest input voltage that should be seen on the digital input pins. This pin is also the supply for the digital output signals on the control port and MP pins. Always set IOVDD to 3.3 V. The current draw of this pin is variable because it is dependent on the loads of the digital outputs.
19	MP11	D_IO	Multipurpose GPIO or Serial Output Port BCLK (OUTPUT_BCLK). See the Multipurpose Pins section for more details.
20	ADDR1/CDATA/WB	D_IN	I ² C Address 1/SPI Data Input/EEPROM Write Back Trigger. This is a multifunction pin as follows: ADDR1: I ² C Address 1. In combination with ADDR0, this sets the I ² C address of the IC so that four ADAU1701 devices can be used on the same I ² C bus. See the I ² C Port section for details. CDATA: SPI Data Input. See the SPI Port section for details. WB: EEPROM Writeback Trigger. A rising (default) or falling (if set in the EEPROM messages) edge on this pin triggers a writeback of the interface registers to the external EEPROM. This function can be used to save parameter data on power-down. See the Self-Boot section for details.
21	CLATCH/WP	D_IO	SPI Latch Signal/Self-Boot EEPROM Write Protect. This is a multifunction pin as follows: CLATCH: SPI Latch Signal. Must go low at the beginning of an SPI transaction and high at the end of a transaction. Each SPI transaction can take a different number of cycles on the CCLK pin to complete, depending on the address and read/write bit that are sent at the beginning of the SPI transaction. See the SPI Port section for details. WP: Self-Boot EEPROM Write Protect. This pin is an open-collector output when in self-boot mode. The ADAU1701 pulls this low to enable writes to an external EEPROM. This pin should be pulled high to 3.3 V. See the Self-Boot section for details.
22	SDA/COUT	D_IO	I ² C Data/SPI Data Output. This is a multifunction pin, as follows: SDA: I ² C Data. This pin is a bidirectional open-collector. The line connected to this pin should have a 2.2 k Ω pull-up resistor. See the I ² C Port section for details. COUT: This SPI data output is used for reading back registers and memory locations. It is three-stated when an SPI read is not active. See the SPI Port section for details.
23	SCL/CCLK	D_IO	I ² C Clock/SPI Clock. This is a dual function pin, as follows: SCL: I ² C Clock. This pin is always an open-collector input when in I ² C control mode. In self-boot mode, this pin is an open-collector output (I ² C master). The line connected to this pin should have a 2.2 k Ω pull-up resistor. See the I ² C Port section for details. CCLK: SPI Clock. This pin can either run continuously or be gated off between SPI transactions. See the SPI Port section for details.
26	MP9	D_IO/A_IO	Multipurpose GPIO, Serial Output Port Data 3 (SDATA_OUT3), or Auxiliary ADC Input 0. See the Multipurpose Pins section for more details.
27	MP8	D_IO/A_IO	Multipurpose GPIO, Serial Output Port Data 2 (SDATA_OUT2), or Auxiliary ADC Input 3. See the Multipurpose Pins section for more details.
28	MP3	D_IO/A_IO	Multipurpose GPIO, Serial Input Port Data 3 (SDATA_IN3), or Auxiliary ADC Input 2. See the Multipurpose Pins section for more details.
29	MP2	D_IO/A_IO	Multipurpose GPIO, Serial Input Port Data 2 (SDATA_IN2), or Auxiliary ADC Input 1. See the Multipurpose Pins section for more details.
30	RSVD		Reserved. Tie to ground, either directly or through a pull-down resistor.
31	OSCO	D_OUT	Crystal Oscillator Circuit Output. Connect a 100 Ω damping resistor between this pin and the crystal. Do not use this output to directly drive a clock to another IC. If the crystal oscillator is not used, this pin can be left disconnected. See the Using the Oscillator section for details.
32	MCLKI	D_IN	Master Clock Input. MCLKI can either be connected to a 3.3 V clock signal or be the input from the crystal oscillator circuit. See the Setting Master Clock/PLL Mode section for details.

Pin No.	Mnemonic	Type ¹	Description
33	PGND	PWR	PLL Ground Pin. The AGND, DGND, and PGND pins can be tied directly together in a common ground plane. Decouple PGND to PVDD by using a 100 nF capacitor.
34	PVDD	PWR	3.3 V Power Supply for the PLL and the Auxiliary ADC Analog Section. Decouple this pin to PGND by using a 100 nF capacitor.
35	PLL_LF	A_OUT	PLL Loop Filter Connection. Two capacitors and a resistor need to be connected to this pin, as shown in Figure 15. See the Setting Master Clock/PLL Mode section for more details.
36, 48	AVDD	PWR	3.3V Analog Supply. Decouple this pin to AGND by using a 100 nF capacitor.
38, 39	PLL_MODE0, PLL_MODE1	D_IN	PLL Mode Setting. PLL_MODE0 and PLL_MODE1 set the output frequency of the master clock PLL. See the Setting Master Clock/PLL Mode section for more details.
40	CM	A_OUT	1.5 V Common-Mode Reference. Connect a 47 μ F decoupling capacitor between this pin and ground to reduce crosstalk between the ADCs and DACs. The material of the capacitors is not critical. This pin can be used to bias external analog circuits, as long as those circuits are not drawing current from the pin (such as when CM is connected to the noninverting input of an op amp).
41	FILTD	A_OUT	DAC Filter Decoupling Pin. Connect a 10 μ F capacitor between this pin and ground. The capacitor material is not critical. The voltage on this pin is 1.5 V.
43 to 46	VOUT3	A_OUT	VOUT DAC Output. The full-scale output voltage is 0.9 V rms. This output can be used with either an active or passive output reconstruction filter. See the Audio DACs section for details.
44	VOUT2	A_OUT	VOUT2 DAC Output. The full-scale output voltage is 0.9 V rms. This output can be used with either an active or passive output reconstruction filter. See the Audio DACs section for details.
45	VOUT1	A_OUT	VOUT1 DAC Output. The full-scale output voltage is 0.9 V rms. This output can be used with either an active or passive output reconstruction filter. See the Audio DACs section for details.
46	VOUT0	A_OUT	VOUT0 DAC Output. The full-scale output voltage is 0.9 V rms. This output can be used with either an active or passive output reconstruction filter. See the Audio DACs section for details.
47	FILTA	A_OUT	ADC Filter Decoupling Pin. A 10 μ F capacitor should be connected between this pin and ground. The capacitor material is not critical. The voltage on this pin is 1.5 V.

¹ PWR = power/ground, A_IN = analog input, D_IN = digital input, A_OUT = analog output, D_IO = digital input/output, D_IO/A_IO = digital input/output or analog input/output.

TYPICAL PERFORMANCE CHARACTERISTICS

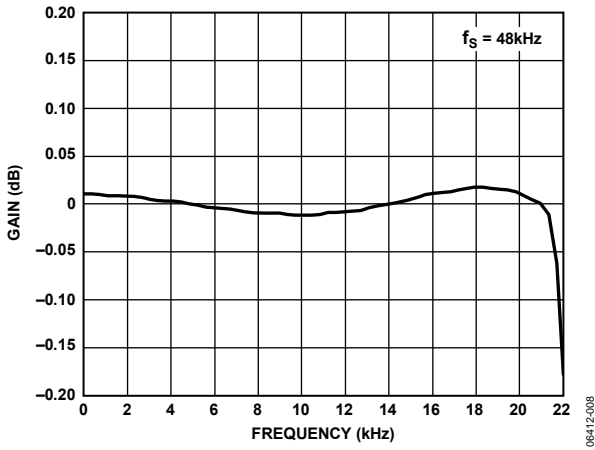

Figure 8. ADC Pass-Band Filter Response

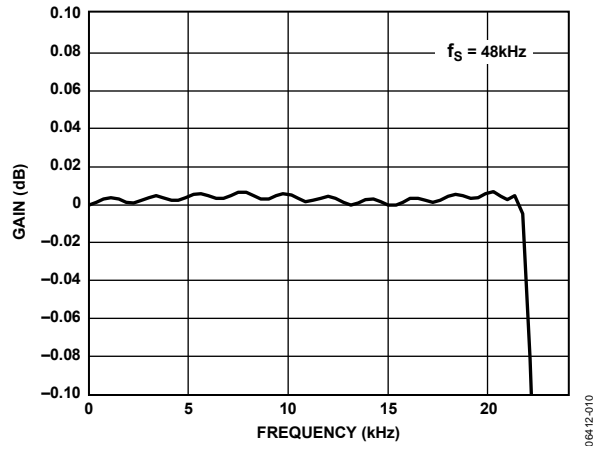

Figure 10. DAC Pass-Band Filter Response

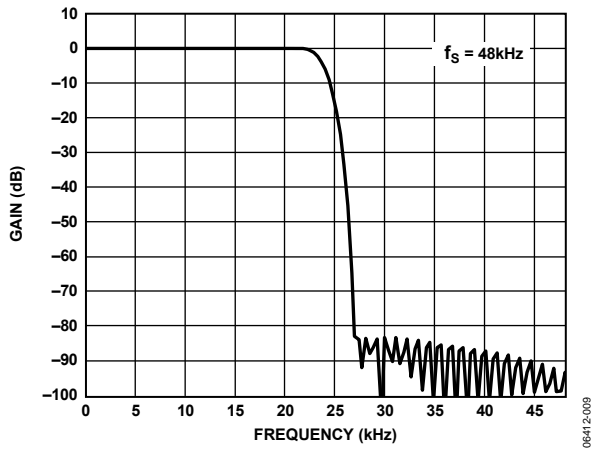

Figure 9. ADC Stop-Band Filter Response

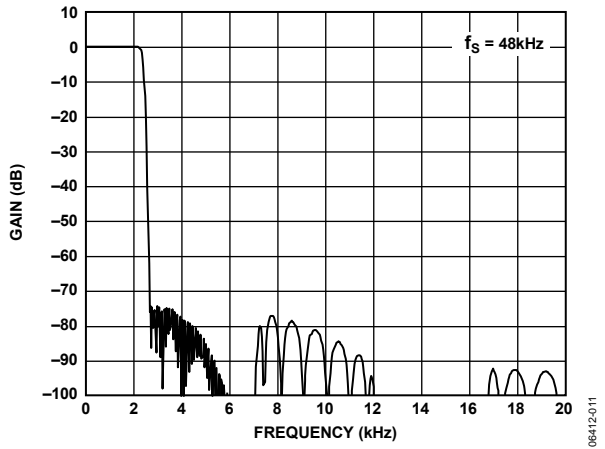

Figure 11. DAC Stop-Band Filter Response

SYSTEM BLOCK DIAGRAM

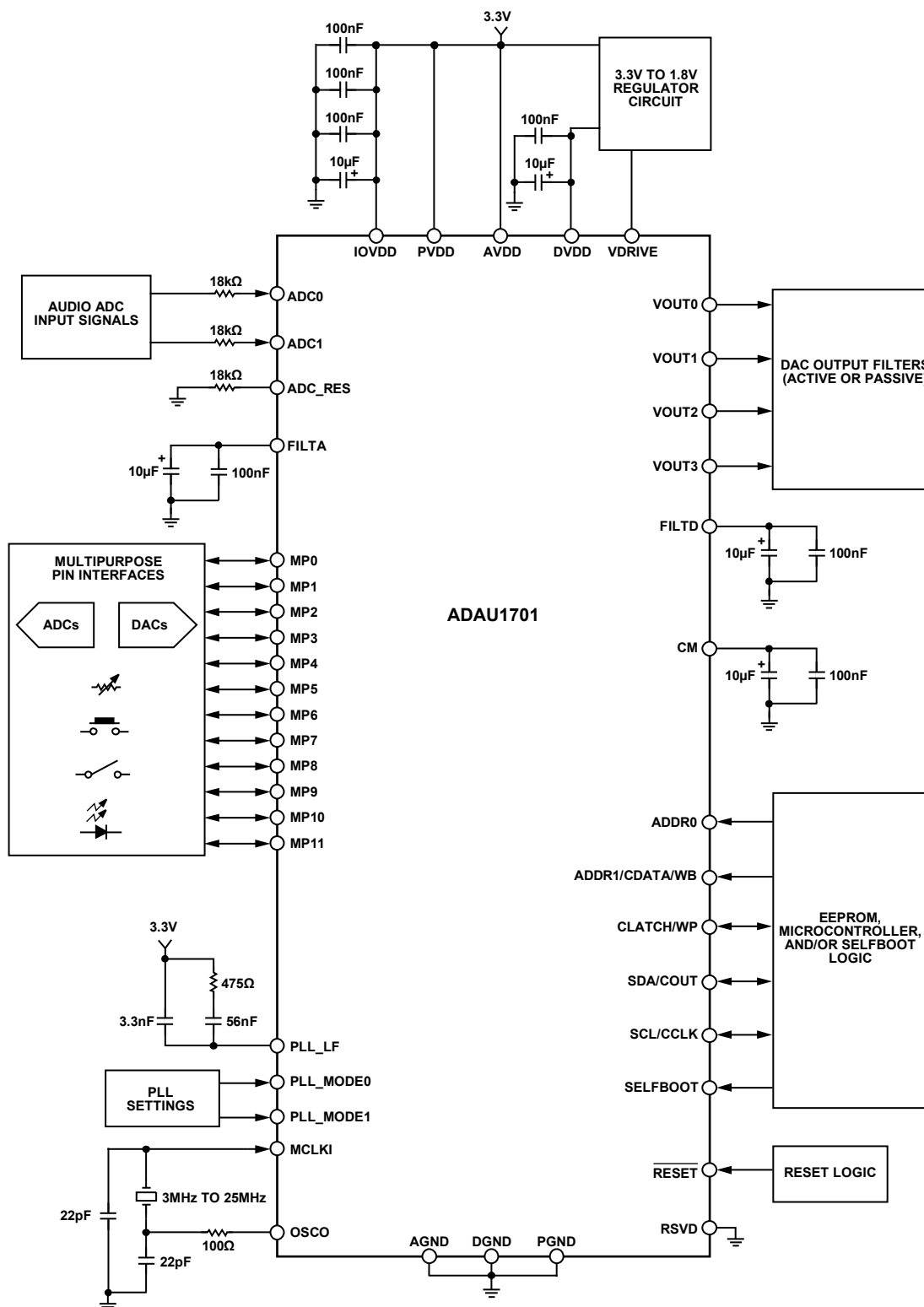

Figure 12. System Block Diagram

06412012

THEORY OF OPERATION

The core of the ADAU1701 is a 28-bit DSP (56-bit with double-precision processing) optimized for audio processing. The program and parameter RAMs can be loaded with a custom audio processing signal flow built by using SigmaStudio graphical programming software from Analog Devices, Inc. The values stored in the parameter RAM control individual signal processing blocks, such as equalization filters, dynamics processors, audio delays, and mixer levels. A safeload feature allows for transparent parameter updates and prevents clicks in the output signals.

The program RAM, parameter RAM, and register contents can be saved in an external EEPROM, from which the ADAU1701 can self-boot on startup. In this standalone mode, parameters can be controlled through the on-board multipurpose pins. The ADAU1701 can accept controls from switches, potentiometers, rotary encoders, and IR receivers. Parameters such as volume and tone settings can be saved to the EEPROM on power-down and recalled again on power-up.

The ADAU1701 can operate with digital or analog inputs and outputs, or a mix of both. The stereo ADC and four DACs each have an SNR of at least +100 dB and a THD + N of at least -83 dB. The 8-channel, flexible serial data input/output ports allow glueless interconnection to a variety of ADCs, DACs, general-purpose DSPs, S/PDIF receivers and transmitters, and sample rate converters. The serial ports of the ADAU1701 can be configured in I²S, left-justified, right-justified, or TDM serial port-compatible modes.

Twelve multipurpose (MP) pins allow the ADAU1701 to receive external control signals as input and to output flags or controls to other devices in the system. The MP pins can be configured as digital I/Os, inputs to the 4-channel auxiliary ADC, or serial data I/O ports. As inputs, they can be connected to buttons, switches, rotary encoders, potentiometers, IR receivers, or other external circuitry to control the internal signal processing program. When configured as outputs, these pins can be used to drive LEDs, control other ICs, or connect to other external circuitry in an application.

The ADAU1701 has a sophisticated control port that supports complete read/write capability of all memory locations. Control registers are provided to offer complete control of the configuration and serial modes of the chip. The ADAU1701 can be configured for either SPI or I²C control, or can self-boot from an external EEPROM.

An on-board oscillator can be connected to an external crystal to generate the master clock. In addition, a master clock phase-locked loop (PLL) allows the ADAU1701 to be clocked from a

variety of different clock speeds. The PLL can accept inputs of $64 \times f_s$, $256 \times f_s$, $384 \times f_s$, or $512 \times f_s$ to generate the internal master clock of the core.

The SigmaStudio software is used to program and control the SigmaDSP® through the control port. Along with designing and tuning a signal flow, the tools can be used to configure all of the DSP registers and burn a new program into the external EEPROM. The SigmaStudio graphical interface allows anyone with digital or analog audio processing knowledge to easily design a DSP signal flow and port it to a target application. At the same time, it provides enough flexibility and programmability for an experienced DSP programmer to have in-depth control of the design. In SigmaStudio, the user can connect graphical blocks (such as biquad filters, dynamics processors, mixers, and delays), compile the design, and load the program and parameter files into the ADAU1701 memory through the control port. Signal processing blocks available in the provided libraries include

- Single- and double-precision biquad filters
- Processors with peak or rms detection for monochannel and multichannel dynamics
- Mixers and splitters
- Tone and noise generators
- Fixed and variable gain
- Loudness
- Delay
- Stereo enhancement
- Dynamic bass boost
- Noise and tone sources
- FIR filters
- Level detectors
- GPIO control and conditioning

Additional processing blocks are always being developed. Analog Devices also provides proprietary and third-party algorithms for applications such as matrix decoding, bass enhancement, and surround virtualizers. Contact Analog Devices for information about licensing these algorithms.

The ADAU1701 operates from a 1.8 V digital power supply and a 3.3 V analog supply. An on-board voltage regulator can be used to operate the chip from a single 3.3 V supply. It is fabricated on a single monolithic, integrated circuit and is packaged in a 48-lead LQFP for operation over the 0°C to +70°C temperature range.

INITIALIZATION

This section details the procedure for properly setting up the ADAU1701. The following five-step sequence provides an overview of how to initialize the IC:

1. Apply power to ADAU1701.
2. Wait for PLL to lock.
3. Load SigmaDSP program and parameters.
4. Set up registers (including multipurpose pins and digital interfaces).
5. Turn off the default muting of the converters, clear the data registers, and initialize the DAC setup register (see the Control Registers Setup section for specific settings).

To only test analog audio pass-through (ADCs to DACs), skip Step 3 and Step 4 and use the default internal program.

POWER-UP SEQUENCE

The ADAU1701 has a built-in power-up sequence that initializes the contents of all internal RAMs on power-up or when the device is brought out of a reset. On the positive edge of $\overline{\text{RESET}}$, the contents of the internal program boot ROM are copied to the internal program RAM memory, the parameter RAM is filled with values (all 0s) from its associated boot ROM, and all registers are initialized to 0s. The default boot ROM program copies audio from the inputs to the outputs without processing it (see Figure 13). In this program, serial digital Input 0 and Input 1 are output on DAC0 and DAC1 and serial digital Output 0 and Output 1. ADC0 and ADC1 are output on DAC2 and DAC3. The data memories are also zeroed at power-up. New values should not be written to the control port until the initialization is complete.

Table 11. Power-Up Time

MCLKI Input	Init. Time	Max Program/Parameter/Register Boot Time (I ² C)	Total
3.072 MHz ($64 \times f_s$)	85 ms	175 ms	260 ms
11.289 MHz ($256 \times f_s$)	23 ms	175 ms	198 ms
12.288 MHz ($256 \times f_s$)	21 ms	175 ms	196 ms
18.432 MHz ($384 \times f_s$)	16 ms	175 ms	191 ms
24.576 MHz ($512 \times f_s$)	11 ms	175 ms	186 ms

The PLL start-up time lasts for 2^{18} cycles of the clock on the MCLKI pin. This time ranges from 10.7 ms for a 24.576 MHz ($512 \times f_s$) input clock to 85.3 ms for a 3.072 MHz ($64 \times f_s$) input clock and is measured from the rising edge of $\overline{\text{RESET}}$. Following the PLL startup, the duration of the ADAU1701 boot cycle is about 42 μs for a f_s of 48 kHz. The user should avoid writing to or reading from the ADAU1701 during this start-up time. For an MCLK input of 12.288 MHz, the full initialization sequence (PLL startup plus boot cycle) is approximately 21 ms. As the device comes out of a reset, the clock mode is immediately set by the PLL_MODE0 and PLL_MODE1 pins. The reset is synchronized to the falling edge of the internal clock.

Table 11 lists typical times to boot the ADAU1701 into an operational state of an application, assuming a 400 kHz I²C clock loading a full program, parameter set, and all registers (about 8.5 kB). In reality, most applications do not fill the RAMs and therefore boot time (Column 3 of Table 11) is less.

CONTROL REGISTERS SETUP

The following registers must be set as described in this section to initialize the ADAU1701. These settings are the basic minimum settings needed to operate the IC with an analog input/output of 48 kHz. More registers may need to be set, depending on the application. See the RAMs and Registers section for additional settings.

DSP Core Control Register (Address 2076)

Set Bits[4:2] (ADM, DAM, and CR) each to 1.

DAC Setup Register (Address 2087)

Set Bits[0:1] (DS[1:0]) to 01.

RECOMMENDED PROGRAM/PARAMETER LOADING PROCEDURE

When writing large amounts of data to the program or parameter RAM in direct write mode, the processor core should be disabled to prevent unpleasant noises from appearing in the audio output.

1. Set Bit 3 and Bit 4 (active low) of the core control register to 1 to mute the ADCs and DACs. This begins a volume ramp-down.
2. Set Bit 2 (active low) of the core control register to 1. This zeroes the SigmaDSP accumulators, the data output registers, and the data input registers.
3. Fill the program RAM using burst mode writes.
4. Fill the parameter RAM using burst mode writes.
5. Deassert Bit 2 to Bit 4 of the core control register.

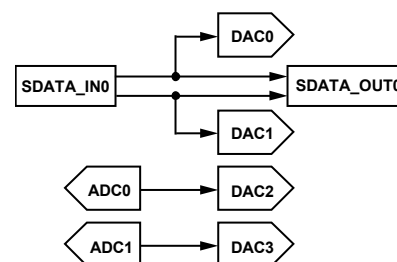

Figure 13. Default Program Signal Flow

POWER REDUCTION MODES

Sections of the ADAU1701 chip can be turned on and off as needed to reduce power consumption. These include the ADCs, DACs, and voltage reference.

The individual analog sections can be turned off by writing to the auxiliary ADC and power control register. By default, the ADCs, DACs, and reference are enabled (all bits set to 0). Each of these can be turned off by writing a 1 to the appropriate bits

ADAU1701

in this register. The ADC power-down mode powers down both ADCs, and each DAC can be powered down individually. The current savings is about 15 mA when the ADCs are powered down and about 4 mA for each DAC that is powered down. The voltage reference, which is supplied to both the ADCs and DACs, should only be powered down if all ADCs and DACs are powered down. The reference is powered down by setting both Bit 6 and Bit 7 of the control register.

USING THE OSCILLATOR

The ADAU1701 can use an on-board oscillator to generate its master clock. The oscillator is designed to work with a $256 \times f_s$ master clock, which is 12.288 MHz for a f_s of 48 kHz and 11.2896 MHz for a f_s of 44.1 kHz. The crystal in the oscillator circuit should be an AT-cut, parallel resonator operating at its fundamental frequency. Figure 14 shows the external circuit recommended for proper operation.

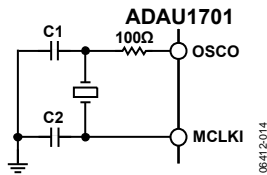

Figure 14. Crystal Oscillator Circuit

The 100 Ω damping resistor on OSCO gives the oscillator a voltage swing of approximately 2.2 V. The crystal shunt capacitance should be 7 pF. Its load capacitance should be about 18 pF, although the circuit supports values of up to 25 pF. The necessary values of the C1 and C2 load capacitors can be calculated from the crystal load capacitance as follows:

$$C_L = \frac{C1 \times C2}{C1 + C2} + C_{stray}$$

where C_{stray} is the stray capacitance in the circuit and is usually assumed to be approximately 2 pF to 5 pF.

OSCO should not be used to directly drive the crystal signal to another IC. This signal is an analog sine wave, and it is not appropriate to use it to drive a digital input. There are two options for using the ADAU1701 to provide a master clock to other ICs in the system. The first, and less recommended, method is to use a high impedance input digital buffer on the OSCO signal. If this is done, minimize the trace length to the buffer input. The second method is to use a clock from the serial output port. Pin MP11 can be set as an output (master) clock divided down from the internal core clock. If this pin is set to serial output port (OUTPUT_BCLK) mode in the multipurpose pin configuration register (2081) and the port is set to master in the serial output control register (2078), the desired output frequency can also be set in the serial output control register with Bits[OBF<1:0>] (see Table 48).

If the oscillator is not utilized in the design, it can be powered down to save power. This can be done if a system master clock is already available in the system. By default, the oscillator is powered on. The oscillator powers down when a 1 is written to the OPD bit of the oscillator power-down register (see Table 59).

SETTING MASTER CLOCK/PLL MODE

The MCLKI input of the ADAU1701 feeds a PLL, which generates the 50 MIPS SigmaDSP core clock. In normal operation, the input to MCLKI must be one of the following: $64 \times f_s$, $256 \times f_s$, $384 \times f_s$, or $512 \times f_s$, where f_s is the input sampling rate. The mode is set on PLL_MODE0 and PLL_MODE1 as described in Table 12. If the ADAU1701 is set to receive double-rate signals (by reducing the number of program steps per sample by a factor of 2 using the core control register), the master clock frequency must be $32 \times f_s$, $128 \times f_s$, $192 \times f_s$, or $256 \times f_s$. If the ADAU1701 is set to receive quad-rate signals (by reducing the number of program steps per sample by a factor of 4 using the core control register), the master clock frequency must be $16 \times f_s$, $64 \times f_s$, $96 \times f_s$, or $128 \times f_s$. On power-up, a clock signal must be present on the MCLKI pin so that the ADAU1701 can complete its initialization routine.

Table 12. PLL Modes

MCLKI Input	PLL_MODE0	PLL_MODE1
$64 \times f_s$	0	0
$256 \times f_s$	0	1
$384 \times f_s$	1	0
$512 \times f_s$	1	1

The clock mode should not be changed without also resetting the ADAU1701. If the mode is changed during operation, a click or pop can result in the output signals. The state of the PLL_MODEx pins should be changed while RESET is held low.

The PLL loop filter should be connected to the PLL_LF pin. This filter, shown in Figure 15, includes three passive components—two capacitors and a resistor. The values of these components do not need to be exact; the tolerance can be up to 10% for the resistor and up to 20% for the capacitors. The 3.3 V signal shown in Figure 15 can be connected to the AVDD supply of the chip.

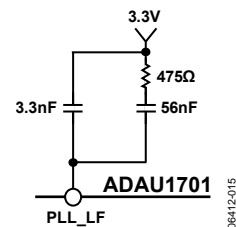

Figure 15. PLL Loop Filter

VOLTAGE REGULATOR

The digital voltage of the ADAU1701 must be set to 1.8 V. The chip includes an on-board voltage regulator that allows the device to be used in systems without an available 1.8 V supply but with an available 3.3 V supply. The only external components needed in such instances are a PNP transistor, a resistor, and a few bypass capacitors. Only one pin, VDRIVE, is necessary to support the regulator.

The recommended design for the voltage regulator is shown in Figure 16. The 10 μF and 100 nF capacitors shown in this configuration are recommended for bypassing, but are not necessary for operation. Each DVDD pin should have its own 100 nF bypass capacitor, but only one bulk capacitor (10 μF to 47 μF) is needed for both DVDD pins. With this configuration, 3.3 V is the main system voltage; 1.8 V is generated at the transistor's collector, which is connected to the DVDD pins. VDRIVE is connected to the base of the PNP transistor. If the regulator is not used in the design, VDRIVE can be tied to ground.

Two specifications must be considered when choosing a regulator transistor: The transistor's current amplification factor (h_{FE} or beta) should be at least 100, and the transistor's collector must be able to dissipate the heat generated when regulating from 3.3 V to 1.8 V. The maximum digital current drawn from the ADAU1701 is 60 mA. The equation to determine the minimum power dissipation of the transistor is as follows:

$$(3.3 \text{ V} - 1.8 \text{ V}) \times 60 \text{ mA} = 90 \text{ mW}$$

There are many transistors, such as the FZT953 from Zetex Semiconductors, with these specifications available in small SOT-23 or SOT-223 packages.

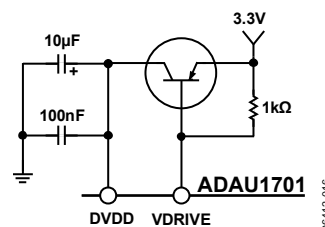

Figure 16. Voltage Regulator Configuration

AUDIO ADCs

The ADAU1701 has two Σ - Δ ADCs. The signal-to-noise ratio (SNR) of the ADCs is 100 dB, and the THD + N is -83 dB.

The stereo audio ADCs are current input; therefore, a voltage-to-current resistor is required on the inputs. This means that the voltage level of the input signals to the system can be set to any level; only the input resistors need to be scaled to provide the proper full-scale current input. The ADC0 and ADC1 input pins, as well as ADC_RES, have an internal 2 k Ω resistor for ESD protection. The voltage seen directly on the ADC input pins is the 1.5 V common mode.

The external resistor connected to ADC_RES sets the full-scale current input of the ADCs. The full range of the ADC inputs is 100 μ A rms with an external 18 k Ω resistor on ADC_RES (20 k Ω total, because it is in series with the internal 2 k Ω). The only reason to change the ADC_RES resistor is if a sampling rate other than 48 kHz is used.

The voltage-to-current resistors connected to ADC0/ADC1 set the full-scale voltage input of the ADCs. With a full-scale current input of 100 μ A rms, a 2.0 V rms signal with an external 18 k Ω resistor (in series with the 2 k Ω internal resistor) results in an input using the full range of the ADC. The matching of these resistors to the ADC_RES resistor is important to the operation of the ADCs. For these three resistors, a 1% tolerance is recommended.

Either the ADC0 and/or ADC1 input pins can be left unconnected if that channel of the ADC is unused.

These calculations of resistor values assume a 48 kHz sample rate. The recommended input and current setting resistors scale linearly with the sample rate because the ADCs have a switched-capacitor input. The total value (2 k Ω internal plus external resistor) of the ADC_RES resistor with sample rate f_{S_NEW} can be calculated as follows:

$$R_{total} = 20 \text{ k}\Omega \times \frac{48,000}{f_{S_NEW}}$$

The values of the resistors (internal plus external) in series with the ADC0 and ADC1 pins can be calculated as follows:

$$R_{Input\ Total} = (rms\ Input\ Voltage) \times 10 \text{ k}\Omega \times \frac{48,000}{f_{S_NEW}}$$

Table 13 lists the external and total resistor values for common signal input levels at a 48 kHz sampling rate. A full-scale rms input voltage of 0.9 V is shown in the table because a full-scale signal at this input level is equal to a full-scale output on the DACs.

Table 13. ADC Input Resistor Values

Full-Scale RMS Input Voltage (V)	ADC_RES Value (k Ω)	ADC0/ADC1 Resistor Value (k Ω)	Total ADC0/ADC1 Input Resistance (External + Internal) (k Ω)
0.9	18	7	9
1.0	18	8	10
2.0	18	18	20

Figure 17 shows a typical configuration of the ADC inputs for a 2.0 V rms input signal for a f_s of 48 kHz. The 47 μ F capacitors are used to ac-couple the signals so that the inputs are biased at 1.5 V.

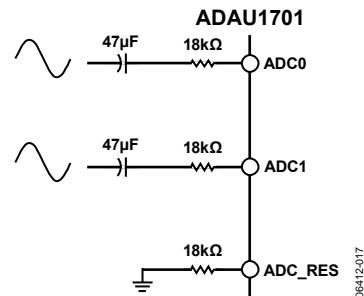

Figure 17. Audio ADC Input Configuration

AUDIO DACs

The ADAU1701 includes four Σ - Δ DACs. The SNR of the DAC is 104 dB, and the THD + N is -90 dB. A full-scale output on the DACs is 0.9 V rms (2.5 V p-p).

The DACs are in an inverting configuration. If a signal inversion from input to output is undesirable, it can be reversed either by using an inverting configuration for the output filter or by simply inverting the signal in the SigmaDSP program flow.

The DAC outputs can be filtered with either an active or a passive reconstruction filter. A single-pole, passive, low-pass filter with a 50 kHz corner frequency, as shown in Figure 18, is sufficient to filter the DAC out-of-band noise, although an active filter may provide better audio performance. Figure 19

shows a triple-pole, active, low-pass filter that provides a steeper roll-off and better stop-band attenuation than the passive filter. In this configuration, the V+ and V- pins of the AD8606 op amp are set to VDD and ground, respectively.

To properly initialize the DACs, Bits[DS<1:0>] in the DAC setup register (Address 2087) should be set to 01.

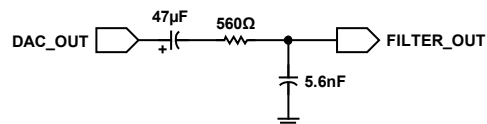

Figure 18. Passive DAC Output Filter

06412-018

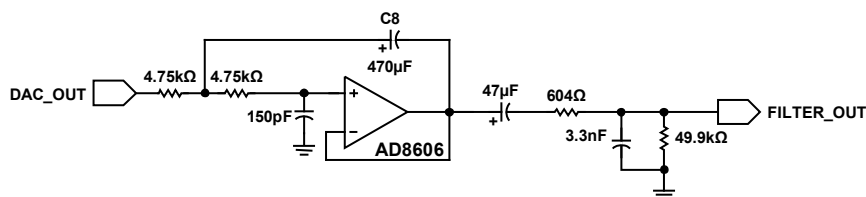

Figure 19. Active DAC Output Filter

06412-019

CONTROL PORTS

The ADAU1701 can operate in one of three control modes:

- I²C control
- SPI control
- Self-boot (no external controller)

The ADAU1701 has both a 4-wire SPI control port and a 2-wire I²C bus control port. Each can be used to set the RAMs and registers. When the SELFB_{OOT} pin is low at power-up, the part defaults to I²C mode but can be put into SPI control mode by pulling the CLATCH/WP pin low three times. When the SELFB_{OOT} pin is set high at power-up, the ADAU1701 loads its program, parameters, and register settings from an external EEPROM on startup.

The control port is capable of full read/write operation for all addressable memory and registers. Most signal processing parameters are controlled by writing new values to the parameter RAM using the control port. Other functions, such as mute and input/output mode control, are programmed by writing to the registers.

All addresses can be accessed in a single-address mode or a burst mode. The first byte (Byte 0) of a control port write contains the 7-bit chip address plus the R/W bit. The next two bytes (Byte 1 and Byte 2) together form the subaddress of the memory or register location within the ADAU1701. This subaddress must be two bytes because the memory locations within the ADAU1701 are directly addressable and their sizes

exceed the range of single-byte addressing. All subsequent bytes (starting with Byte 3) contain the data, such as control port data, program data, or parameter data. The number of bytes per word depends on the type of data that is being written. The exact formats for specific types of writes are shown in Table 21 to Table 30.

The ADAU1701 has several mechanisms for updating signal processing parameters in real time without causing pops or clicks. If large blocks of data need to be downloaded, the output of the DSP core can be halted (using the CR bit in the DSP core control register (Address 2076)), new data can be loaded, and then the device can be restarted. This is typically done during the booting sequence at startup or when loading a new program into RAM. In cases where only a few parameters need to be changed, they can be loaded without halting the program. To avoid unwanted side effects while loading parameters on the fly, the SigmaDSP provides the safeload registers. The safeload registers can be used to buffer a full set of parameters (for example, the five coefficients of a biquad) and then transfer these parameters into the active program within one audio frame. The safeload mode uses internal logic to prevent contention between the DSP core and the control port.

The control port pins are multifunctional, depending on the mode in which the part is operating. Table 14 details these multiple functions.

Table 14. Control Port Pins and SELFB_{OOT} Pin Functions

Pin	I ² C Mode	SPI Mode	Self-Boot
SCL/CCLK	SCL—input	CCLK—input	SCL—output
SDA/COUT	SDA—open-collector output	COUT—output	SDA—open-collector output
ADDR1/CDATA/WB	ADDR1—input	CDATA—input	WB—writeback trigger
CLATCH/WP	Unused input—tie to ground or IOVDD	CLATCH—input	WP—EEPROM write protect, open-collector output
ADDR0	ADDR0—input	ADDR0—input	Unused input—tie to ground or IOVDD

I²C PORT

The ADAU1701 supports a 2-wire serial (I²C-compatible) microprocessor bus driving multiple peripherals. Two pins, serial data (SDA) and serial clock (SCL), carry information between the ADAU1701 and the system I²C master controller. In I²C mode, the ADAU1701 is always a slave on the bus, meaning it cannot initiate a data transfer. Each slave device is recognized by a unique address. The address byte format is shown in Table 15. The ADAU1701 slave addresses are set with the ADDR0 and ADDR1 pins. The address resides in the first seven bits of the I²C write. The LSB of this byte sets either a read or write operation. Logic Level 1 corresponds to a read operation, and Logic Level 0 corresponds to a write operation. Bit 5 and Bit 6 of the address are set by tying the ADDR_x pins of the ADAU1701 to Logic Level 0 or Logic Level 1. The full byte addresses, including the pin settings and read/write (R/W) bit, are shown in Table 16.

Burst mode addressing, where the subaddresses are automatically incremented at word boundaries, can be used for writing large amounts of data to contiguous memory locations. This increment happens automatically after a single-word write unless a stop condition is encountered. The registers and RAMs in the ADAU1701 range in width from one to five bytes, so the auto-increment feature knows the mapping between subaddresses and the word length of the destination register (or memory location). A data transfer is always terminated by a stop condition.

Both SDA and SCL should have 2.2 kΩ pull-up resistors on the lines connected to them. The voltage on these signal lines should not be more than IOVDD (3.3 V).

Table 15. ADAU1701 I²C Address Byte Format

Bit 0	Bit 1	Bit 2	Bit 3	Bit 4	Bit 5	Bit 6	Bit 7
0	1	1	0	1	ADDR1	ADDR0	R/W

Table 16. ADAU1701 I²C Addresses

ADDR1	ADDR0	R/W	Slave Address
0	0	0	0x68
0	0	1	0x69
0	1	0	0x6A
0	1	1	0x6B
1	0	0	0x6C
1	0	1	0x6D
1	1	0	0x6E
1	1	1	0x6F

Addressing

Initially, each device on the I²C bus is in an idle state monitoring the SDA and SCL lines for a start condition and the proper address. The I²C master initiates a data transfer by establishing a start condition, defined by a high-to-low transition on SDA while SCL remains high. This indicates that an address/data stream follows. All devices on the bus respond to the start condition and shift the next eight bits (the 7-bit address plus the R/W bit) MSB first. The device that recognizes the transmitted address responds by pulling the data line low during the ninth clock pulse. This ninth bit is known as an acknowledge bit. All other devices withdraw from the bus at this point and return to the idle condition. The R/W bit determines the direction of the data. A Logic 0 on the LSB of the first byte means the master writes information to the peripheral, whereas a Logic 1 means the master reads information from the peripheral after writing the subaddress and repeating the start address. A data transfer takes place until a stop condition is encountered. A stop condition occurs when SDA transitions from low to high while SCL is held high. Figure 20 shows the timing of an I²C write, and Figure 21 shows an I²C read.

Stop and start conditions can be detected at any stage during the data transfer. If these conditions are asserted out of sequence with normal read and write operations, the ADAU1701 immediately jumps to the idle condition. During a given SCL high period, the user should only issue one start condition, one stop condition, or a single stop condition followed by a single start condition. If an invalid subaddress is issued by the user, the ADAU1701 does not issue an acknowledge and returns to the idle condition. If the user exceeds the highest subaddress while in auto-increment mode, one of two actions is taken. In read mode, the ADAU1701 outputs the highest subaddress register contents until the master device issues a no acknowledge, indicating the end of a read. A no-acknowledge condition is where the SDA line is not pulled low on the ninth clock pulse on SCL. On the other hand, if the highest subaddress location is reached while in write mode, the data for the invalid byte is not loaded into any subaddress register, a no acknowledge is issued by the ADAU1701, and the part returns to the idle condition.

ADAU1701

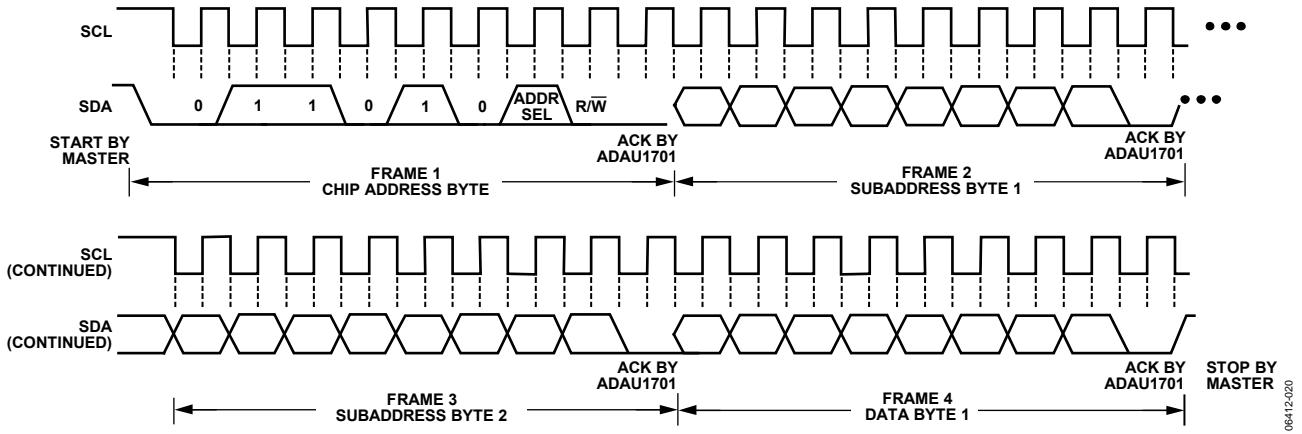

Figure 20. I²C Write to ADAU1701 Clcking

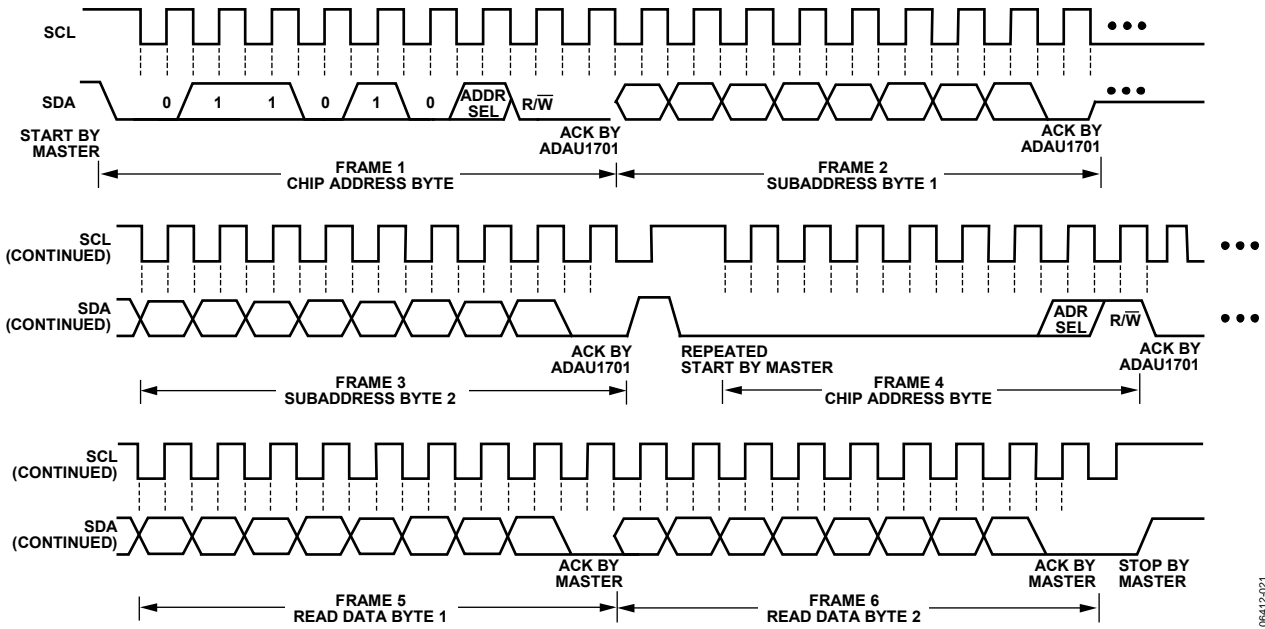

Figure 21. I²C Read from ADAU1701 Clcking

I²C Read and Write Operations

Figure 22 shows the timing of a single-word write operation. Every ninth clock, the ADAU1701 issues an acknowledge by pulling SDA low.

Figure 23 shows the timing of a burst mode write sequence. This figure shows an example where the target destination registers are two bytes. The ADAU1701 knows to increment its subaddress register every two bytes because the requested subaddress corresponds to a register or memory area with a 2-byte word length.

The timing of a single-word read operation is shown in Figure 24. Note that the first R/W bit is 0, indicating a write operation. This is because the subaddress still needs to be written to set up the internal address. After the ADAU1701 acknowledges the receipt of the subaddress, the master must issue a repeated start command followed by the chip address byte with the R/W set to 1 (read). This causes the ADAU1701 SDA to reverse and begin driving data back to the master. The

master then responds every ninth pulse with an acknowledge pulse to the ADAU1701.

Figure 25 shows the timing of a burst mode read sequence. This figure shows an example where the target read registers are two bytes. The ADAU1701 increments its subaddress every two bytes because the requested subaddress corresponds to a register or memory area with word lengths of two bytes. Other addresses may have word lengths ranging from one to five bytes. The ADAU1701 always decodes the subaddress and sets the auto-increment circuit so that the address increments after the appropriate number of bytes.

Figure 22 to Figure 25 use the following abbreviations:

S = start bit

P = stop bit

AM = acknowledge by master

AS = acknowledge by slave

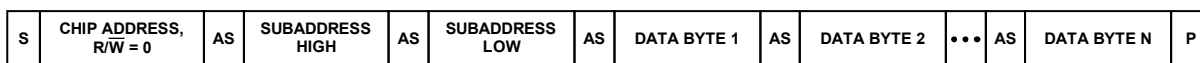

Figure 22. Single Word I²C Write Format

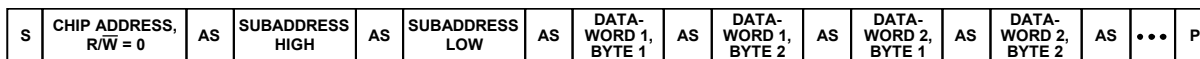

Figure 23. Burst Mode I²C Write Format

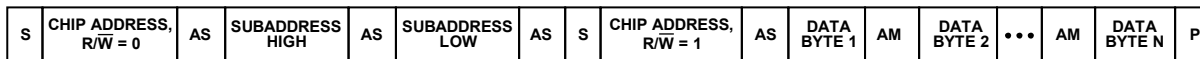

Figure 24. Single-Word I²C Read Format

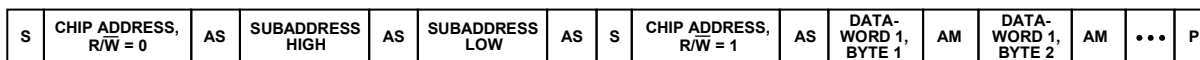

Figure 25. Burst Mode I²C Read Format

ADAU1701

SPI PORT

By default, the ADAU1701 is in I²C mode, but it can be put into SPI control mode by pulling CLATCH/WP low three times. The SPI port uses a 4-wire interface, consisting of CLATCH, CCLK, CDATA, and COUT signals, and is always a slave port. The CLATCH signal should go low at the beginning of a transaction and high at the end of a transaction. The CCLK signal latches CDATA during a low-to-high transition. COUT data is shifted out of the ADAU1701 on the falling edge of CCLK and should be clocked into a receiving device, such as a microcontroller, on the CCLK rising edge. The CDATA signal carries the serial input data, and the COUT signal is the serial output data. The COUT signal remains three-stated until a read operation is requested. This allows other SPI-compatible peripherals to share the same readback line. All SPI transactions have the same basic format shown in Table 18. A timing diagram is shown in Figure 3. All data should be written MSB first. The ADAU1701 cannot be taken out of SPI mode without a full reset.

Chip Address R/W

The first byte of an SPI transaction includes the 7-bit chip address and a R/W bit. The chip address is set by the ADDR0 pin. This allows two ADAU1701s to share a CLATCH signal, yet still operate independently. When ADDR0 is low, the chip address is 0000000; when it is high, the address is 0000001 (see Table 17). The LSB of this first byte determines whether the SPI transaction is a read (Logic Level 1) or a write (Logic Level 0).

Table 18. Generic Control Word Format

Byte 0	Byte 1	Byte 2	Byte 3	Byte 4 ¹
chip_adr[6:0], R/W	0000, subadr[11:8]	subadr[7:0]	data	data

¹ Continues to end of data.

Table 17. ADAU1701 SPI Address Byte Format

Bit 0	Bit 1	Bit 2	Bit 3	Bit 4	Bit 5	Bit 6	Bit 7
0	0	0	0	0	0	ADDR0	R/W

Subaddress

The 12-bit subaddress word is decoded into a location in one of the memories or registers. This subaddress is the location of the appropriate RAM location or register. The MSBs of the subaddress are zero-padded to bring the word to a full 2-byte length.

Data Bytes

The number of data bytes varies according to the register or memory being accessed. During a burst mode write, an initial subaddress is written followed by a continuous sequence of data for consecutive memory/register locations. The detailed data format for continuous mode operation is shown in Table 22 and Table 24 in the Read/Write Data Formats section.

A sample timing diagram for a single-write SPI operation to the parameter RAM is shown in Figure 26. A sample timing diagram of a single-read SPI operation is shown in Figure 27. The COUT pin goes from three-state to being driven at the beginning of Byte 3. In this example, Byte 0 to Byte 2 contain the addresses and the R/W bit and subsequent bytes carry the data.

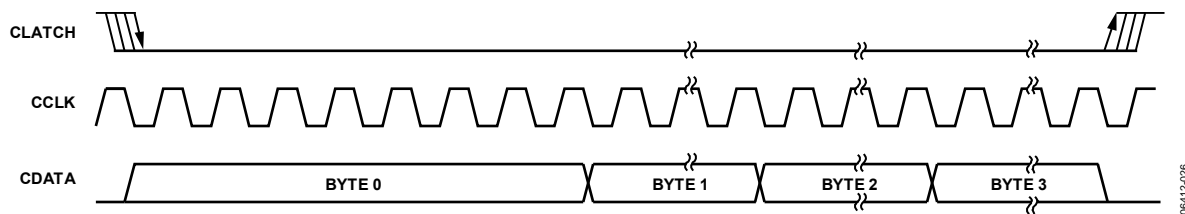

Figure 26. SPI Write to ADAU1701 Clocking (Single-Write Mode)

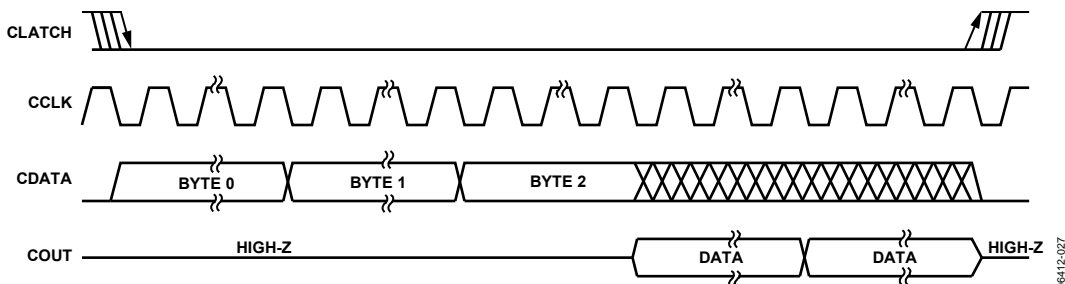

Figure 27. SPI Read from ADAU1701 Clocking (Single-Read Mode)

SELF-BOOT

On power-up, the ADAU1701 can load a program and a set of parameters that have been saved in an external EEPROM. Combined with the auxiliary ADC and the multipurpose pins, this eliminates the need for a microcontroller in the system. The self-booting is accomplished by the ADAU1701 acting as a master on the I²C bus on startup, which occurs when the SELFBOOT pin is set high. The ADAU1701 cannot self-boot in SPI mode.

The maximum necessary EEPROM size for program and parameters is 9248 bytes, or just over 8.5 kB. This does not include register settings or overhead bytes, but such factors do not add a significant number of bytes. This much memory is only needed if the program RAM (1024 × five bytes), parameter RAM (1024 × four bytes), and interface registers (8 × four bytes) are completely full. Most applications do not use the full program and parameter RAMs, so an 8 kB EEPROM should be sufficient.

A self-boot operation is triggered on the rising edge of $\overline{\text{RESET}}$ when the SELFBOOT and WP pins are set high. The ADAU1701 reads the program, parameters, and register settings from the EEPROM. After the ADAU1701 finishes self-booting, additional messages can be sent to the ADAU1701 on the I²C bus, although this typically is not necessary in a self-booting application. The I²C device address is 0x68 for a write and 0x69 for a read in this mode. The ADDR_x pins have different functions when the chip is in this mode, so the settings on them can be ignored.

The ADAU1701 does not self-boot if WP is set low. Holding this pin low allows the EEPROM to be programmed in-circuit. The WP pin is pulled low (it typically has a resistor pull-up) to enable writes to the EEPROM, but this in turn disables the self-boot function until the WP pin is returned high.

The ADAU1701 is a master on the I²C bus during self-boot and writeback. Although it is uncommon for an application using self-boot to also have a microcontroller connected to the control lines, care should be taken that no other device tries to write to the I²C bus during self-boot or writeback. The ADAU1701 generates SCL at $8 \times f_s$; therefore, for a f_s of 48 kHz, SCL runs at 384 kHz. SCL has a duty cycle of 3/8 in accordance with the I²C specification.

The ADAU1701 reads from EEPROM Chip Address 0xA1. The LSBs of the addresses of some EEPROMs are pin configurable; in most cases, these pins should be tied low to set this address.

EEPROM Format

The EEPROM data contains a sequence of messages. Each discrete message is one of the seven types defined in Table 19 and consists of a sequence of one or more bytes. The first byte identifies the message type. Bytes are written MSB first. Most messages are block write (0x01) types, which are used for writing to the ADAU1701 program RAM, parameter RAM, and control registers.

The body of the message following the message type should start with a 0x00 byte; this is the chip address. As with all other control port transactions, following the chip address is a 2-byte register/memory address field.

Figure 28 shows an example of what should be stored in the EEPROM, starting with EEPROM Address 0. In this example, the interface registers are first set to control port write mode (Line 1), which is followed by 18 no-operation (no-op) bytes (Line 2 to Line 4) so that the interface register data appears on Page 2 of the EEPROM. Next follows the write header (Line 4) and then 32 bytes of interface register data (Line 5 to Line 8). Finally, the program RAM data, starting at ADAU1701 Address 0x04 0x00 is written (Line 9 to Line 11). In this example, the program length is 70 words, or 350 bytes, so 332 more bytes are included in the EEPROM but are not shown in Figure 28.

Writeback

A writeback occurs when the WB pin is triggered and data is written to the EEPROM from the ADAU1701. This function is typically used to save the volume setting and other parameter settings to the EEPROM just before power is removed from the system. A rising edge on the WB pin triggers a writeback when the device is in self-boot mode, unless a message to set the WB to the falling edge sensitive (0x05) is contained in the self-boot message sequence. Only one writeback takes place unless a message to set multiple writebacks (0x04) is contained in the self-boot message sequence. The WP pin is pulled low when a writeback is triggered to allow writing to the EEPROM.

The ADAU1701 is only capable of writing back the contents of the interface registers to the EEPROM. These registers are usually set by the DSP program, but can also be written to directly after setting Bit 6 of the core control register. The parameter settings that should be saved are configured in SigmaStudio.

ADAU1701

The writeback function writes data from the ADAU1701 interface registers to the second page of the self-boot EEPROM, Address 32 to Address 63. Starting at EEPROM Address 26 (so that the interface register data begins at Address 32), the EEPROM should be programmed with six bytes—the message byte (0x01), two length bytes, the chip address (0x00), and the 2-byte subaddress for the interface registers (0x08 0x00). There must be a message to the DSP core control register to enable writing to the interface registers prior to the interface register data in the EEPROM. This should be stored in EEPROM Address 0. No-op messages (0x03) can be used in between messages to ensure that these conditions are met.

The ADAU1701 writes to EEPROM Chip Address 0xA0. The LSBs of the addresses of some EEPROMs are pin configurable; in most cases, these pins should be tied low to set the address to 0xA0.

The maximum number of bytes that is written back from the ADAU1701 is 35 (eight 4-byte interface registers plus three bytes of EEPROM-addressing overhead). With SCL running at 384 kHz, the writeback operation takes approximately 73 μ s to complete after being triggered. Ensure that sufficient power is available to the system to allow enough time for a writeback to complete, especially if the WB signal is triggered from a falling power supply voltage.

Table 19. EEPROM Message Types

Message ID	Message Type	Following Bytes
0x00	End	None
0x01	Write	Two bytes indicating message length followed by appropriate number of data bytes
0x02	Delay	Two bytes for delay
0x03	No operation executed	None
0x04	Set multiple writeback	None
0x05	Set WB to falling edge sensitive	None
0x06	End and wait for writeback	None

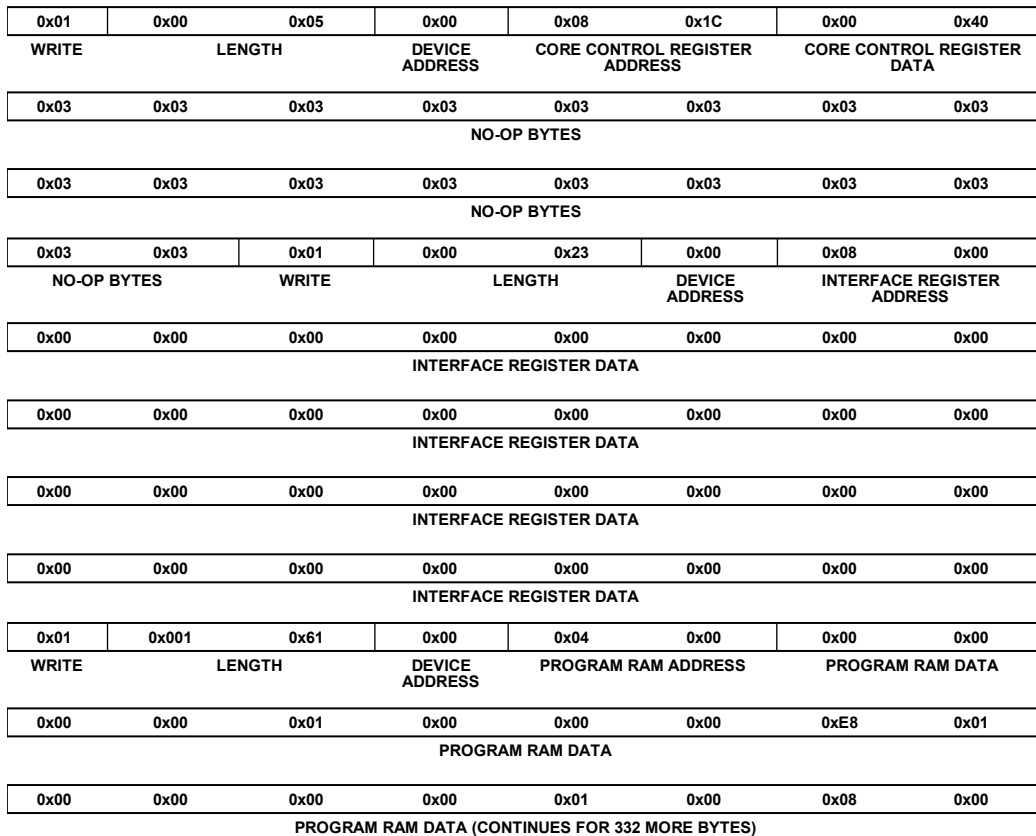

Figure 28. EEPROM Data Example

06412-039

SIGNAL PROCESSING

The ADAU1701 is designed to provide all audio signal processing functions commonly used in stereo or multichannel playback systems. The signal processing flow is designed using the SigmaStudio software, which allows graphical entry and real-time control of all signal processing functions.

Many of the signal processing functions are coded using full, 56-bit, double-precision arithmetic data. The input and output word lengths of the DSP core are 24 bits. Four extra headroom bits are used in the processor to allow internal gains of up to 24 dB without clipping. Additional gains can be achieved by initially scaling down the input signal in the DSP signal flow.

NUMERIC FORMATS

DSP systems commonly use a standard numeric format. Fractional number systems are specified by an A.B format, where A is the number of bits to the left of the decimal point and B is the number of bits to the right of the decimal point.

The ADAU1701 uses the same numeric format for both the parameter and data values. The format is as follows.

Numerical Format: 5.23

Linear range: -16.0 to $(+16.0 - 1 \text{ LSB})$

Examples:

- 1000 0000 0000 0000 0000 0000 = -16.0
- 1110 0000 0000 0000 0000 0000 = -4.0
- 1111 1000 0000 0000 0000 0000 = -1.0
- 1111 1110 0000 0000 0000 0000 = -0.25
- 1111 1111 0011 0011 0011 0011 = -0.1
- 1111 1111 1111 1111 1111 1111 = $(1 \text{ LSB below } 0.0)$
- 0000 0000 0000 0000 0000 0000 = 0.0
- 0000 0000 1100 1100 1100 1101 = 0.1
- 0000 0010 0000 0000 0000 0000 = 0.25
- 0000 1000 0000 0000 0000 0000 = 1.0
- 0010 0000 0000 0000 0000 0000 = 4.0
- 0111 1111 1111 1111 1111 1111 = $(16.0 - 1 \text{ LSB})$.

The serial port accepts up to 24 bits on the input and is sign-extended to the full 28 bits of the DSP core. This allows internal gains of up to 24 dB without internal clipping.

A digital clipper circuit is used between the output of the DSP core and the DACs or serial port outputs (see Figure 29). This clips the top four bits of the signal to produce a 24-bit output

with a range of 1.0 (minus 1 LSB) to -1.0 . Figure 29 shows the maximum signal levels at each point in the data flow in both binary and decibel levels.

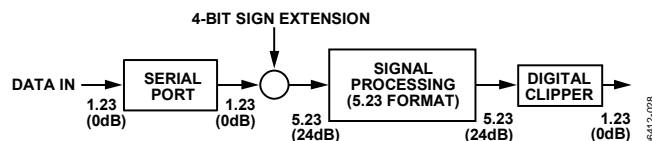

Figure 29. Numeric Precision and Clipping Structure

PROGRAMMING

On power-up, the ADAU1701 default program passes the unprocessed input signals to the outputs (shown in Figure 13), but the outputs are muted by default (see the Power-Up Sequence section). There are 1024 instruction cycles per audio sample, resulting in about 50 MIPS available. The SigmaDSP runs in a stream-oriented manner, meaning that all 1024 instructions are executed each sample period. The ADAU1701 can also be set up to accept double- or quad-speed inputs by reducing the number of instructions per sample that are set in the core control register.

The part can be easily programmed using SigmaStudio (Figure 30), a graphical tool provided by Analog Devices. No knowledge of writing line-level DSP code is required. More information about SigmaStudio can be found at www.analog.com.

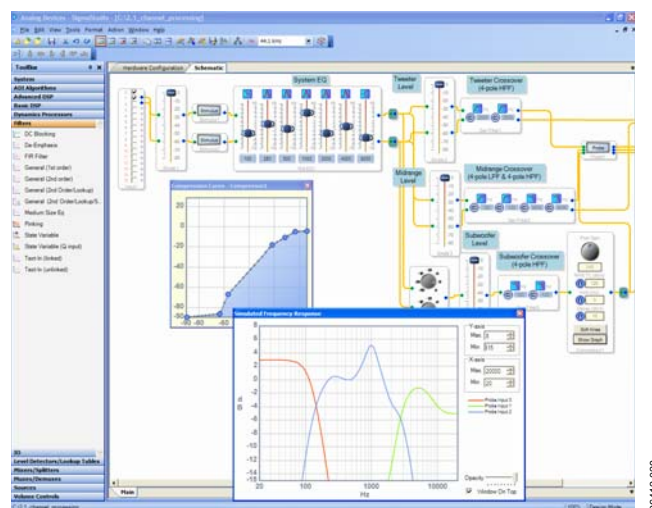

Figure 30. SigmaStudio Screen Shot

RAMS AND REGISTERS

Table 20. RAM Map and Read/Write Modes

Memory	Size	Address Range	Read	Write	Write Modes
Parameter RAM	1024 × 32	0 to 1023 (0x0000 to 0x03FF)	Yes	Yes	Direct write ¹ safeload write
Program RAM	1024 × 40	1024 to 2047 (0x0400 to 0x07FF)	Yes	Yes	Direct write ¹

¹ Internal registers should be cleared first to avoid clicks/pops.

ADDRESS MAPS

Table 20 shows the RAM map and Table 31 shows the ADAU1701 register map. The address space encompasses a set of registers and two RAMs: one holds signal processing parameters and one holds the program instructions. The program RAM and parameter RAM are initialized on power-up from on-board boot ROMs (see the Power-Up Sequence section).

All RAMs and registers have a default value of all 0s, except for the program RAM, which is loaded with the default program (see the Initialization section).

PARAMETER RAM

The parameter RAM is 32 bits wide and occupies Address 0 to Address 1023. Each parameter is padded with four 0s before the MSB to extend the 28-bit word to a full 4-byte width. The parameter RAM is initialized to all 0s on power-up. The data format of the parameter RAM is twos complement, 5.23. This means that the coefficients can range from +16.0 (minus 1 LSB) to -16.0, with 1.0 represented by the binary word 0000 1000 0000 0000 0000 0000 or by the hexadecimal word 0x00 0x80 0x00 0x00.

The parameter RAM can be written using one of the two following methods: a direct read/write or a safeload write.

Direct Read/Write

The direct read/write method allows direct access to the program RAM and parameter RAM. This mode of operation is typically used when loading a new RAM using burst mode addressing. The clear registers bit in the core control register should be set to 0 using this mode to avoid any clicks or pops in the outputs. Note that this mode can be used during live program execution, but because there is no handshaking between the core and the control port, the parameter RAM is unavailable to the DSP core during control writes, resulting in clicks and pops in the audio stream.

Safeload Write

Up to five safeload registers can be loaded with the parameter RAM address/data. The data is then transferred to the requested address when the RAM is not busy. This method can be used for dynamic updates while live program material is playing through the ADAU1701. For example, a complete update of one biquad section can occur in one audio frame while the RAM is not busy. This method is not available for writing to the program RAM or control registers.

DATA RAM

The ADAU1701 data RAM is used to store audio data words for processing. For the most part, this process is transparent to the user. The user cannot address this RAM space, which has a size of 2k words, directly from the control port.

Data RAM utilization should be considered when implementing blocks that require large amounts of data RAM space, such as delays. The SigmaDSP core processes delay times in one-sample increments; therefore, the total pool of delay available to the user equals 2048 multiplied by the sample period. For a f_s of 48 kHz, the pool of available delay is a maximum of about 43 ms. In practice, this much data memory is not available to the user because every block in a design uses a few data memory locations for its processing. In most DSP programs, this does not significantly impact the total delay time. The SigmaStudio compiler manages the data RAM and indicates if the number of addresses needed in the design exceeds the maximum available.

READ/WRITE DATA FORMATS

The read/write formats of the control port are designed to be byte oriented. This allows easy programming of common microcontroller chips. To fit into a byte-oriented format, 0s are appended to the data fields before the MSB to extend the data-word to eight bits. For example, 28-bit words written to the parameter RAM are appended with four leading 0s to equal 32 bits (four bytes); 40-bit words written to the program RAM are not appended with 0s because they are already a full five bytes. These zero-padded data fields are appended to a 3-byte field consisting of a 7-bit chip address, a read/write bit, and an 11-bit RAM/register address. The control port knows how many data bytes to expect based on the address given in the first three bytes.

The total number of bytes for a single-location write command can vary from four bytes (for a control register write) to eight bytes (for a program RAM write). Burst mode can be used to fill contiguous register or RAM locations. A burst mode write begins by writing the address and data of the first RAM or register location to be written. Rather than ending the control port transaction (by issuing a stop command in I²C mode or by bringing the CLATCH signal high in SPI mode after the data-word), as would be done in a single-address write, the next data-word can be immediately written without specifying its address. The ADAU1701 control port auto-increments the address of each write even across the boundaries of the different RAMs and registers. Table 22 and Table 24 show examples of burst mode writes.

Table 21. Parameter RAM Read/Write Format (Single Address)

Byte 0	Byte 1	Byte 2	Byte 3	Bytes[4:6]
chip_adr[6:0], $\overline{W/R}$	000000, param_adr[9:8]	param_adr[7:0]	0000, param[27:24]	param[23:0]

Table 22. Parameter RAM Block Read/Write Format (Burst Mode)

Byte 0	Byte 1	Byte 2	Byte 3	Bytes[4:6]	Bytes[7:10]	Bytes[11:14]
chip_adr[6:0], $\overline{W/R}$	000000, param_adr[9:8]	param_adr[7:0]	0000, param[27:24]	param[23:0]		
\leftarrow param_adr \rightarrow				param_adr + 1	param_adr + 2	

Table 23. Program RAM Read/Write Format (Single Address)

Byte 0	Byte 1	Byte 2	Bytes[3:7]
chip_adr[6:0], $\overline{W/R}$	00000, prog_adr[10:8]	prog_adr[7:0]	prog[39:0]

Table 24. Program RAM Block Read/Write Format (Burst Mode)

Byte 0	Byte 1	Byte 2	Bytes[3:7]	Bytes[8:12]	Bytes[13:17]
chip_adr[6:0], $\overline{W/R}$	00000, prog_adr[10:8]	prog_adr[7:0]	prog[39:0]		
\leftarrow prog_adr \rightarrow				prog_adr + 1	prog_adr + 2

Table 25. Control Register Read/Write Format (Core, Serial Out 0, Serial Out 1)

Byte 0	Byte 1	Byte 2	Byte 3	Byte 4
chip_adr[6:0], $\overline{W/R}$	0000, reg_adr[11:8]	reg_adr[7:0]	data[15:8]	data[7:0]

Table 26. Control Register Read/Write Format (RAM Configuration, Serial Input)

Byte 0	Byte 1	Byte 2	Byte 3
chip_adr[6:0], $\overline{W/R}$	0000, reg_adr[11:8]	reg_adr[7:0]	data[7:0]

Table 27. Data Capture Register Write Format

Byte 0	Byte 1	Byte 2	Byte 3	Byte 4
chip_adr[6:0], $\overline{W/R}$	0000, data_capture_adr[11:8]	data_capture_adr[7:0]	000, progCount[10:6] ¹	progCount[5:0] ¹ , regSel[1:0] ²

¹ progCount[10:0] is the value of the program counter when the data capture occurs (the table of values is generated by the SigmaStudio compiler).

² regSel[1:0] selects one of four registers (see the 2074 to 2075 (0X081A to 0X081B)—Data Capture Registers section).

Table 28. Data Capture (Control Port Readback) Register Read Format

Byte 0	Byte 1	Byte 2	Bytes[3:5]
chip_adr[6:0], $\overline{W/R}$	0000, data_capture_adr[11:8]	data_capture_adr[7:0]	data[23:0]

Table 29. Safeload Address Register Write Format

Byte 0	Byte 1	Byte 2	Byte 3	Byte 4
chip_adr[6:0], $\overline{W/R}$	0000, safeload_adr[11:8]	safeload_adr[7:0]	000000, param_adr[9:8]	param_adr[7:0]

Table 30. Safeload Data Register Write Format

Byte 0	Byte 1	Byte 2	Byte 3	Byte 4	Bytes[5:7]
chip_adr[6:0], $\overline{W/R}$	0000, safeload_adr[11:8]	safeload_adr[7:0]	00000000	0000, data[27:24]	data[23:0]

CONTROL REGISTER MAP

Table 31. Register Map¹

Register Address		No. of Bytes	Name	MSB																LSB		Default
Hex	Dec			D31	D30	D29	D28	D27	D26	D25	D24	D39	D38	D37	D36	D35	D34	D33	D32			
				D15	D14	D13	D12	D11	D10	D9	D8	D7	D6	D5	D4	D3	D2	D1	D0			
0x0800	2048	4	Interface 0[31:16] Interface 0[15:0]	0 IF15	0 IF14	0 IF13	0 IF12	IF27 IF11	IF26 IF10	IF25 IF09	IF24 IF08	IF23 IF07	IF22 IF06	IF21 IF05	IF20 IF04	IF19 IF03	IF18 IF02	IF17 IF01	IF16 IF00	0x0000 0x0000		
0x0801	2049	4	Interface 0[31:16] Interface 0[15:0]	0 IF15	0 IF14	0 IF13	0 IF12	IF27 IF11	IF26 IF10	IF25 IF09	IF24 IF08	IF23 IF07	IF22 IF06	IF21 IF05	IF20 IF04	IF19 IF03	IF18 IF02	IF17 IF01	IF16 IF00	0x0000 0x0000		
0x0802	2050	4	Interface 0[31:16] Interface 0[15:0]	0 IF15	0 IF14	0 IF13	0 IF12	IF27 IF11	IF26 IF10	IF25 IF09	IF24 IF08	IF23 IF07	IF22 IF06	IF21 IF05	IF20 IF04	IF19 IF03	IF18 IF02	IF17 IF01	IF16 IF00	0x0000 0x0000		
0x0803	2051	4	Interface 0[31:16] Interface 0[15:0]	0 IF15	0 IF14	0 IF13	0 IF12	IF27 IF11	IF26 IF10	IF25 IF09	IF24 IF08	IF23 IF07	IF22 IF06	IF21 IF05	IF20 IF04	IF19 IF03	IF18 IF02	IF17 IF01	IF16 IF00	0x0000 0x0000		
0x0804	2052	4	Interface 0[31:16] Interface 0[15:0]	0 IF15	0 IF14	0 IF13	0 IF12	IF27 IF11	IF26 IF10	IF25 IF09	IF24 IF08	IF23 IF07	IF22 IF06	IF21 IF05	IF20 IF04	IF19 IF03	IF18 IF02	IF17 IF01	IF16 IF00	0x0000 0x0000		
0x0805	2053	4	Interface 0[31:16] Interface 0[15:0]	0 IF15	0 IF14	0 IF13	0 IF12	IF27 IF11	IF26 IF10	IF25 IF09	IF24 IF08	IF23 IF07	IF22 IF06	IF21 IF05	IF20 IF04	IF19 IF03	IF18 IF02	IF17 IF01	IF16 IF00	0x0000 0x0000		
0x0806	2054	4	Interface 0[31:16] Interface 0[15:0]	0 IF15	0 IF14	0 IF13	0 IF12	IF27 IF11	IF26 IF10	IF25 IF09	IF24 IF08	IF23 IF07	IF22 IF06	IF21 IF05	IF20 IF04	IF19 IF03	IF18 IF02	IF17 IF01	IF16 IF00	0x0000 0x0000		
0x0807	2055	4	Interface 0[31:16] Interface 0[15:0]	0 IF15	0 IF14	0 IF13	0 IF12	IF27 IF11	IF26 IF10	IF25 IF09	IF24 IF08	IF23 IF07	IF22 IF06	IF21 IF05	IF20 IF04	IF19 IF03	IF18 IF02	IF17 IF01	IF16 IF00	0x0000 0x0000		
0x0808	2056	2	GPIO pin setting	0	0	0	0	MP11	MP10	MP09	MP08	MP07	MP06	MP05	MP04	MP03	MP02	MP01	MP00	0x0000		
0x0809	2057	2	Auxiliary ADC Data 0	0	0	0	0	AA11	AA10	AA09	AA08	AA07	AA06	AA05	AA04	AA03	AA02	AA01	AA00	0x0000		
0x080A	2058	2	Auxiliary ADC Data 1	0	0	0	0	AA11	AA10	AA09	AA08	AA07	AA06	AA05	AA04	AA03	AA02	AA01	AA00	0x0000		
0x080B	2059	2	Auxiliary ADC Data 2	0	0	0	0	AA11	AA10	AA09	AA08	AA07	AA06	AA05	AA04	AA03	AA02	AA01	AA00	0x0000		
0x080C	2060	2	Auxiliary ADC Data 3	0	0	0	0	AA11	AA10	AA09	AA08	AA07	AA06	AA05	AA04	AA03	AA02	AA01	AA00	0x0000		
0x080D	2061	5	Reserved[39:32] Reserved[31:16] Reserved[15:0]	RSVD RSVD RSVD	RSVD RSVD RSVD	RSVD RSVD RSVD	RSVD RSVD RSVD	RSVD RSVD RSVD	RSVD RSVD RSVD	RSVD RSVD RSVD	RSVD RSVD RSVD	RSVD RSVD RSVD	RSVD RSVD RSVD	RSVD RSVD RSVD	RSVD RSVD RSVD	RSVD RSVD RSVD	RSVD RSVD RSVD	RSVD RSVD RSVD	RSVD RSVD RSVD	0x00 0x0000 0x0000		
0x080E	2062	5	Reserved[39:32] Reserved[31:16] Reserved[15:0]	RSVD RSVD RSVD	RSVD RSVD RSVD	RSVD RSVD RSVD	RSVD RSVD RSVD	RSVD RSVD RSVD	RSVD RSVD RSVD	RSVD RSVD RSVD	RSVD RSVD RSVD	RSVD RSVD RSVD	RSVD RSVD RSVD	RSVD RSVD RSVD	RSVD RSVD RSVD	RSVD RSVD RSVD	RSVD RSVD RSVD	RSVD RSVD RSVD	RSVD RSVD RSVD	0x00 0x0000 0x0000		
0x080F	2063	5	Reserved[39:32] Reserved[31:16] Reserved[15:0]	RSVD RSVD RSVD	RSVD RSVD RSVD	RSVD RSVD RSVD	RSVD RSVD RSVD	RSVD RSVD RSVD	RSVD RSVD RSVD	RSVD RSVD RSVD	RSVD RSVD RSVD	RSVD RSVD RSVD	RSVD RSVD RSVD	RSVD RSVD RSVD	RSVD RSVD RSVD	RSVD RSVD RSVD	RSVD RSVD RSVD	RSVD RSVD RSVD	RSVD RSVD RSVD	0x00 0x0000 0x0000		
0x0810	2064	5	Safeload Data 0[39:32] Safeload Data 0[31:16] Safeload Data 0[15:0]	SD31 SD15	SD30 SD14	SD29 SD13	SD28 SD12	SD27 SD11	SD26 SD10	SD25 SD09	SD24 SD08	SD23 SD07	SD22 SD06	SD21 SD05	SD20 SD04	SD19 SD03	SD18 SD02	SD17 SD01	SD16 SD00	0x00 0x0000 0x0000		
0x0811	2065	5	Safeload Data 1[39:32] Safeload Data 1[31:16] Safeload Data 1[15:0]	SD31 SD15	SD30 SD14	SD29 SD13	SD28 SD12	SD27 SD11	SD26 SD10	SD25 SD09	SD24 SD08	SD23 SD07	SD22 SD06	SD21 SD05	SD20 SD04	SD19 SD03	SD18 SD02	SD17 SD01	SD16 SD00	0x00 0x0000 0x0000		
0x0812	2066	5	Safeload Data 2[39:32] Safeload Data 2[31:16] Safeload Data 2[15:0]	SD31 SD15	SD30 SD14	SD29 SD13	SD28 SD12	SD27 SD11	SD26 SD10	SD25 SD09	SD24 SD08	SD23 SD07	SD22 SD06	SD21 SD05	SD20 SD04	SD19 SD03	SD18 SD02	SD17 SD01	SD16 SD00	0x00 0x0000 0x0000		
0x0813	2067	5	Safeload Data 3[39:32] Safeload Data 3[31:16] Safeload Data 3[15:0]	SD31 SD15	SD30 SD14	SD29 SD13	SD28 SD12	SD27 SD11	SD26 SD10	SD25 SD09	SD24 SD08	SD23 SD07	SD22 SD06	SD21 SD05	SD20 SD04	SD19 SD03	SD18 SD02	SD17 SD01	SD16 SD00	0x00 0x0000 0x0000		
0x0814	2068	5	Safeload Data 4[39:32] Safeload Data 4[31:16] Safeload Data 4[15:0]	SD31 SD15	SD30 SD14	SD29 SD13	SD28 SD12	SD27 SD11	SD26 SD10	SD25 SD09	SD24 SD08	SD23 SD07	SD22 SD06	SD21 SD05	SD20 SD04	SD19 SD03	SD18 SD02	SD17 SD01	SD16 SD00	0x00 0x0000 0x0000		
0x0815	2069	2	Safeload Address 0	0	0	0	0	SA11	SA10	SA09	SA08	SA07	SA06	SA05	SA04	SA03	SA02	SA01	SA00	0x0000		
0x0816	2070	2	Safeload Address 1	0	0	0	0	SA11	SA10	SA09	SA08	SA07	SA06	SA05	SA04	SA03	SA02	SA01	SA00	0x0000		
0x0817	2071	2	Safeload Address 2	0	0	0	0	SA11	SA10	SA09	SA08	SA07	SA06	SA05	SA04	SA03	SA02	SA01	SA00	0x0000		
0x0818	2072	2	Safeload Address 3	0	0	0	0	SA11	SA10	SA09	SA08	SA07	SA06	SA05	SA04	SA03	SA02	SA01	SA00	0x0000		
0x0819	2073	2	Safeload Address 4	0	0	0	0	SA11	SA10	SA09	SA08	SA07	SA06	SA05	SA04	SA03	SA02	SA01	SA00	0x0000		
0x081A	2074	2	Data Capture 0	0	0	0	0	PC09	PC08	PC07	PC06	PC05	PC04	PC03	PC02	PC01	PC00	RS01	RS00	0x0000		
0x081B	2075	2	Data Capture 1	0	0	0	0	PC09	PC08	PC07	PC06	PC05	PC04	PC03	PC02	PC01	PC00	RS01	RS00	0x0000		
0x081C	2076	2	DSP core control	RSVD	RSVD	GD1	GD0	RSVD	RSVD	RSVD	AACW	GPCW	IFCW	IST	ADM	DAM	CR	SR1	SR0	0x0000		
0x081D	2077	1	Reserved	RSVD	RSVD	RSVD	RSVD	RSVD	RSVD	RSVD	RSVD	RSVD	RSVD	RSVD	RSVD	RSVD	RSVD	RSVD	RSVD	0x00		
0x081E	2078	2	Serial output control	0	0	OLRP	OBP	M/S	OBF1	OBF0	OLF1	OLF0	FST	TDM	MSB2	MSB1	MSB0	OWL1	OWL0	0x0000		
0x081F	2079	1	Serial input control									0	0	0	ILP	IBP	M2	M1	M0	0x00		

Register Address		No. of Bytes	Name	MSB														LSB		Default		
				D31 D15	D30 D14	D29 D13	D28 D12	D27 D11	D26 D10	D25 D9	D24 D8	D39 D7	D38 D6	D37 D5	D36 D4	D35 D3	D34 D2	D33 D1	D32 D0			
0x0820	2080	3	MP Pin Config. 0[23:16]											MP53	MP52	MP51	MP50	MP43	MP42	MP41	MP40	0x00
			MP Pin Config. 0[15:0]	MP33	MP32	MP31	MP30	MP23	MP22	MP21	MP20	MP13	MP12	MP11	MP10	MP03	MP02	MP01	MP00	0x0000		
0x0821	2081	3	MP Pin Config. 1[23:16]											MP113	MP112	MP111	MP110	MP103	MP102	MP101	MP100	0x00
			MP Pin Config. 1[15:0]	MP93	MP92	MP91	MP90	MP83	MP82	MP81	MP80	MP73	MP72	MP71	MP70	MP63	MP62	MP61	MP60	0x0000		
0x0822	2082	2	Auxiliary ADC and power control	RSVD	RSVD	RSVD	RSVD	RSVD	RSVD	FIL1	FIL0	AAPD	VBPD	VRPD	RSVD	D0PD	D1PD	D2PD	D3PD	0x0000		
0x0823	2083	2	Reserved	RSVD	RSVD	RSVD	RSVD	RSVD	RSVD	RSVD	RSVD	RSVD	RSVD	RSVD	RSVD	RSVD	RSVD	RSVD	RSVD	0x0000		
0x0824	2084	2	Auxiliary ADC enable	AAEN	RSVD	RSVD	RSVD	RSVD	RSVD	RSVD	RSVD	RSVD	RSVD	RSVD	RSVD	RSVD	RSVD	RSVD	RSVD	0x0000		
0x0825	2085	2	Reserved	RSVD	RSVD	RSVD	RSVD	RSVD	RSVD	RSVD	RSVD	RSVD	RSVD	RSVD	RSVD	RSVD	RSVD	RSVD	RSVD	0x0000		
0x0826	2086	2	Oscillator power-down	RSVD	RSVD	RSVD	RSVD	RSVD	RSVD	RSVD	RSVD	RSVD	RSVD	RSVD	RSVD	RSVD	OPD	RSVD	RSVD	0x0000		
0x0827	2087	2	DAC setup	RSVD	RSVD	RSVD	RSVD	RSVD	RSVD	RSVD	RSVD	RSVD	RSVD	RSVD	RSVD	RSVD	RSVD	DS1	DS0	0x0000		

¹ Shading indicates that registers do not fill these locations, so control bits do not exist in these locations.

CONTROL REGISTER DETAILS

2048 TO 2055 (0x0800 TO 0x0807)—INTERFACE REGISTERS

The interface registers are used in self-boot mode to save parameters that need to be written to the external EEPROM. The ADAU1701 then recalls these parameters from the EEPROM after the next reset or power-up. Therefore, system parameters such as volume and EQ settings can be saved during power-down and recalled the next time the system is turned on.

There are eight 32-bit interface registers, which allow eight 28-bit (plus zero-padding) parameters to be saved. The parameters to

be saved in these registers are selected in the graphical programming tools. These registers are updated with their corresponding parameter RAM data once per sample period.

An edge, which can be set to be either rising or falling, triggers the ADAU1701 to write the current contents of the interface registers to the EEPROM. See the Self-Boot section for details.

The user can write directly to the interface registers after the interface registers control port write mode (IFCW) in the DSP core control register has been set. In this mode, the data in the registers is written from the control port, not from the DSP core.

Table 32. Interface Register Bit Map

D31	D30	D29	D28	D27	D26	D25	D24	D23	D22	D21	D20	D19	D18	D17	D16	
D15	D14	D13	D12	D11	D10	D9	D8	D7	D6	D5	D4	D3	D2	D1	D0	Default
0	0	0	0	IF27	IF26	IF25	IF24	IF23	IF22	IF21	IF20	IF19	IF18	IF17	IF16	0x0000
IF15	IF14	IF13	IF12	IF11	IF10	IF09	IF08	IF07	IF06	IF05	IF04	IF03	IF02	IF01	IF00	0x0000

Table 33.

Bit Name	Description
IF[27:0]	Interface register 28-bit parameter

2056 (0x0808)—GPIO PIN SETTING REGISTER

This register allows the user to set the GPIO pins through the control port. High or low settings can be directly written to or

read from this register after setting the GPIO pin setting register control port write mode (GPCW) in the core control register. This register is updated once every LRCLK frame ($1/f_s$).

Table 34. GPIO Pin Setting Register Bit Map

D15	D14	D13	D12	D11	D10	D9	D8	D7	D6	D5	D4	D3	D2	D1	D0	Default
0	0	0	0	MP11	MP10	MP09	MP08	MP07	MP06	MP05	MP04	MP03	MP02	MP01	MP00	0x0000

Table 35.

Bit Name	Description
MP[11:0]	Setting of multipurpose pin when controlled through SPI or I ² C

ADAU1701

2057 TO 2060 (0x0809 TO 0x080C)—AUXILIARY ADC DATA REGISTERS

These registers hold the data generated by the 4-channel auxiliary ADC. The ADCs have eight bits of precision and can be extended to 12 bits if filtering is selected via Bits FIL[1:0] of the auxiliary ADC and power control register. The SigmaDSP program reads this data as a 1.11 format data-word with a range

of 0 to 1.0. This data-word is mapped to the 5.23 format parameter word with the four MSBs and 12 LSBs set to 0. A full-scale code of 255 results in a value of 1.0. These registers can be written to directly if the auxiliary ADC data registers control port write mode (AACW) bit is set in the DSP core control register.

Table 36. Auxiliary ADC Data Register Bit Map

D15	D14	D13	D12	D11	D10	D9	D8	D7	D6	D5	D4	D3	D2	D1	D0	Default
0	0	0	0	AA11	AA10	AA09	AA08	AA07	AA06	AA05	AA04	AA03	AA02	AA01	AA00	0x0000

Table 37.

Bit Name	Description
AA[11:0]	Auxiliary ADC output data, MSB first

2064 TO 2068 (0x0810 TO 0x0814)—SAFELOAD DATA REGISTERS

Many applications require real-time microcontroller control of signal processing parameters, such as filter coefficients, mixer gains, multichannel virtualizing parameters, or dynamics processing curves. When controlling a biquad filter, for example, all of the parameters must be updated at the same time. Doing so prevents the filter from executing with a mix of old and new coefficients for one or two audio frames, thus avoiding temporary instability and transients that may take a long time to decay. To accomplish this, the ADAU1701 uses safeload data registers to simultaneously load a set of five 28-bit values to the desired parameter RAM address. Five registers are used because a biquad filter uses five coefficients and, as previously mentioned, it is desirable to do a complete update in one transaction.

The first step in performing a safeload operation is writing the parameter address to one of the safeload address registers (2069 to 2073). The 10-bit data-word to be written is the address in parameter RAM to which the safeload is being performed. After this address is written, the 28-bit data-word can be written to the corresponding safeload data register (2064 to 2068).

The data formats for these writes are detailed in Table 29 and Table 30. Table 38 shows how each of the five address registers maps to its corresponding data register.

After the address and data registers are loaded, set the initiate safeload transfer bit in the core control register to initiate the loading into RAM. Each of the five safeload registers takes one of the 1024 core instructions to load into the parameter RAM. The total program lengths should, therefore, be limited to 1019 cycles (1024 minus 5) to ensure that the SigmaDSP core always has at least five cycles available. The safeload is guaranteed to occur within one LRCLK period (21 μ s for a f_s of 48 kHz) of the initiate safeload transfer bit being set.

The safeload logic automatically sends data to be loaded into RAM from only those safeload registers that have been written to since the last safeload operation. For example, if two parameters are to be updated in the RAM, only two of the five safeload registers must be written. When the initiate safeload transfer bit is asserted, only data from those two registers are sent to the RAM; the other three registers are not sent to the RAM and may hold old or invalid data.

Table 38. Safeload Address and Data Register Mapping

Safeload Register	Safeload Address Register	Safeload Data Register
0	2069	2064
1	2070	2065
2	2071	2066
3	2072	2067
4	2073	2068

Table 39. Safeload Registers Bit Map

D31 D15	D30 D14	D29 D13	D28 D12	D27 D11	D26 D10	D25 D9	D24 D8	D39 D23 D7	D38 D22 D6	D37 D21 D5	D36 D20 D4	D35 D19 D3	D34 D18 D2	D33 D17 D1	D32 D16 D0	Default
SD31	SD30	SD29	SD28	SD27	SD26	SD25	SD24	SD39	SD38	SD37	SD36	SD35	SD34	SD33	SD32	0x00
SD15	SD14	SD13	SD12	SD11	SD10	SD09	SD08	SD23	SD22	SD21	SD20	SD19	SD18	SD17	SD16	0x0000
								SD07	SD06	SD05	SD04	SD03	SD02	SD01	SD00	0x0000

Table 40.

Bit Name	Description
SD[39:0]	Safeload Data. Data (program, parameters, register contents) to be loaded into the RAMs or registers.

2069 TO 2073 (0x0815 TO 0x0819)—SAFELOAD ADDRESS REGISTERS

Table 41. Safeload Address Registers Bit Map

D15	D14	D13	D12	D11	D10	D9	D8	D7	D6	D5	D4	D3	D2	D1	D0	Default
0	0	0	0	SA11	SA10	SA09	SA08	SA07	SA06	SA05	SA04	SA03	SA02	SA01	SA00	0x0000

Table 42.

Bit Name	Description
SA[11:0]	Safeload Address. Address of data that is to be loaded into the RAMs or registers

ADAU1701

2074 TO 2075 (0x081A TO 0x081B)—DATA CAPTURE REGISTERS

The ADAU1701 data capture feature allows the data at any node in the signal processing flow to be sent to one of two readable registers. This feature is useful for monitoring and displaying information about internal signal levels or compressor/limiter activity.

For each of the data capture registers, a capture count and a register select must be set. The capture count is a number between 0 and 1023 that corresponds to the program step number where the capture is to occur. The register select field programs one of four registers in the DSP core that transfers this information to the data capture register when the program counter reaches this step.

The captured data is in 5.19, twos complement data format, which comes from the internal 5.23 data-word with the four LSBs truncated.

The data that must be written to set up the data capture is a concatenation of the 10-bit program count index with the 2-bit register select field. The capture count and register select values that correspond to the desired point to be monitored in the signal processing flow can be found in a file output from the program compiler. The capture registers can be accessed by reading from Location 2074 and Location 2075. The format for writing and reading to the data capture registers is shown in Table 27 and Table 28.

Table 43. Safeload Data Registers Bit Map

D15	D14	D13	D12	D11	D10	D9	D8	D7	D6	D5	D4	D3	D2	D1	D0	Default
0	0	0	0	PC09	PC08	PC07	PC06	PC05	PC04	PC03	PC02	PC01	PC00	RS01	RS00	0x0000

Table 44.

Bit Name	Description	
PC[9:0]	10-bit program counter address	
RS[1:0]	Select the register to be transferred to the data capture output	
	RS[1:0]	Register
	00	Multiplier X input (Mult_X_input)
	01	Multiplier Y input (Mult_Y_input)
	10	Multiplier-accumulator output (MAC_out)
11	Accumulator feedback (Accum_fback)	

2076 (0x081C)—DSP CORE CONTROL REGISTER

Table 45. DSP Core Control Register Bit Map

D15	D14	D13	D12	D11	D10	D9	D8	D7	D6	D5	D4	D3	D2	D1	D0	Default
RSVD	RSVD	GD1	GD0	RSVD	RSVD	RSVD	AACW	GPCW	IFCW	IST	ADM	DAM	CR	SR1	SR0	0x0000

Table 46. DSP Core Control Register

Bit Name	Description
GD[1:0]	GPIO Debounce Control. Sets debounce time of multipurpose pins that are set as GPIO inputs.
	GD[1:0] Time (ms)
	00 20
	01 40
	10 10
11 5	
AACW	Auxiliary ADC Data Registers Control Port Write Mode. Setting this bit allows data to be written directly to the auxiliary ADC data registers (2057 to 2060) from the control port. When this bit is set, the auxiliary ADC data registers ignore the settings on the multipurpose pins.
GPCW	GPIO Pin Setting Register Control Port Write Mode. When this bit is set, the GPIO pin setting register (2056) can be written to directly from the control port and this register ignores the input settings on the multipurpose pins.
IFCW	Interface Registers Control Port Write Mode. When this bit is set, data can be written directly to the interface registers (2048 to 2055) from the control port. In that state, the interface registers are not written from the SigmaDSP program.
IST	Initiate Safeload Transfer. Setting this bit to 1 initiates a safeload transfer to the parameter RAM. This bit is automatically cleared when the operation is complete. There are five safeload register pairs (address/data); only those registers that have been written since the last safeload event are transferred to the parameter RAM.
ADM	Mute ADCs. This bit mutes the output of the ADCs. The bit defaults to 0 and is active low; therefore, it must be set to 1 to transmit audio signals from the ADCs.
DAM	Mute DACs. This bit mutes the output of the DACs. The bit defaults to 0 and is active low; therefore, it must be set to 1 to transmit audio signals from the DACs.
CR	Clear Internal Registers to 0. This bit defaults to 0 and is active low. It must be set to 1 for a signal to pass through the SigmaDSP core.
SR[1:0]	Sample Rate. These bits set the number of DSP instructions for every sample and the sample rate at which the ADAU1701 operates. At the default setting of 1×, there are 1024 instructions per audio sample. This setting should be used with sample rates such as 48 kHz and 44.1 kHz. At the 2× setting, the number of instructions per frame is halved to 512 and the ADCs and DACs nominally run at a 96 kHz sample rate. At the 4× setting, there are 256 instructions per cycle and the converters run at a 192 kHz sample rate.
	SR[1:0] Setting
	00 1× (1024 instructions)
	01 2× (512 instructions)
	10 4× (256 instructions)
11 Reserved	

ADAU1701

2078 (0x081E)—SERIAL OUTPUT CONTROL REGISTER

Table 47. Serial Output Control Register Bit Map

D15	D14	D13	D12	D11	D10	D9	D8	D7	D6	D5	D4	D3	D2	D1	D0	Default
0	0	OLRP	OBP	M/S	OBF1	OBF0	OLF1	OLF0	FST	TDM	MSB2	MSB1	MSB0	OWL1	OWL0	0x0000

Table 48.

Bit Name	Description																
OLRP	OUTPUT_LRCLK Polarity. When this bit is set to 0, the left-channel data is clocked when OUTPUT_LRCLK is low and the right-channel data is clocked when OUTPUT_LRCLK is high. When this bit is set to 1, the right-channel data is clocked when OUTPUT_LRCLK is low and the left-channel data is clocked when OUTPUT_LRCLK is high.																
OBP	OUTPUT_BCLK Polarity. This bit controls on which edge of the bit clock the output data is clocked. Data changes on the falling edge of OUTPUT_BCLK when this bit is set to 0 and on the rising edge when this bit is set to 1.																
M/S	Master/Slave. This bit sets whether the output port is a clock master or slave. The default setting is slave; on power-up, the OUTPUT_BCLK and OUTPUT_LRCLK pins are set as inputs until this bit is set to 1, at which time they become clock outputs.																
OBF[1:0]	OUTPUT_BCLK Frequency (Master Mode Only). When the output port is being used as a clock master, these bits set the frequency of the output bit clock, which is divided down from an internal $1024 \times f_s$ clock (49.152 MHz for a f_s of 48 kHz).																
	<table border="1"> <thead> <tr> <th>OBF[1:0]</th> <th>Setting</th> </tr> </thead> <tbody> <tr> <td>00</td> <td>Internal clock/16</td> </tr> <tr> <td>01</td> <td>Internal clock/8</td> </tr> <tr> <td>10</td> <td>Internal clock/4</td> </tr> <tr> <td>11</td> <td>Internal clock/2</td> </tr> </tbody> </table>	OBF[1:0]	Setting	00	Internal clock/16	01	Internal clock/8	10	Internal clock/4	11	Internal clock/2						
OBF[1:0]	Setting																
00	Internal clock/16																
01	Internal clock/8																
10	Internal clock/4																
11	Internal clock/2																
OLF[1:0]	OUTPUT_LRCLK Frequency (Master Mode Only). When the output port is used as a clock master, these bits set the frequency of the output word clock on the OUTPUT_LRCLK pins, which is divided down from an internal $1024 \times f_s$ clock (49.152 MHz for a f_s of 48 kHz).																
	<table border="1"> <thead> <tr> <th>OLF[1:0]</th> <th>Setting</th> </tr> </thead> <tbody> <tr> <td>00</td> <td>Internal clock/1024</td> </tr> <tr> <td>01</td> <td>Internal clock/512</td> </tr> <tr> <td>10</td> <td>Internal clock/256</td> </tr> <tr> <td>11</td> <td>Reserved</td> </tr> </tbody> </table>	OLF[1:0]	Setting	00	Internal clock/1024	01	Internal clock/512	10	Internal clock/256	11	Reserved						
OLF[1:0]	Setting																
00	Internal clock/1024																
01	Internal clock/512																
10	Internal clock/256																
11	Reserved																
FST	Frame Sync Type. This bit sets the type of signal on the OUTPUT_LRCLK pins. When this bit is set to 0, the signal is a word clock with a 50% duty cycle; when this bit is set to 1, the signal is a pulse with a duration of one bit clock at the beginning of the data frame.																
TDM	TDM Enable. Setting this bit to 1 changes the output port from four serial stereo outputs to a single 8-channel TDM output stream on the SDATA_OUT0 pin (MP6).																
MSB[2:0]	MSB Position. These three bits set the position of the MSB of data with respect to the LRCLK edge. The data output of the ADAU1701 is always MSB first.																
	<table border="1"> <thead> <tr> <th>MSB[2:0]</th> <th>Setting</th> </tr> </thead> <tbody> <tr> <td>000</td> <td>Delay by 1</td> </tr> <tr> <td>001</td> <td>Delay by 0</td> </tr> <tr> <td>010</td> <td>Delay by 8</td> </tr> <tr> <td>011</td> <td>Delay by 12</td> </tr> <tr> <td>100</td> <td>Delay by 16</td> </tr> <tr> <td>101</td> <td>Reserved</td> </tr> <tr> <td>111</td> <td>Reserved</td> </tr> </tbody> </table>	MSB[2:0]	Setting	000	Delay by 1	001	Delay by 0	010	Delay by 8	011	Delay by 12	100	Delay by 16	101	Reserved	111	Reserved
MSB[2:0]	Setting																
000	Delay by 1																
001	Delay by 0																
010	Delay by 8																
011	Delay by 12																
100	Delay by 16																
101	Reserved																
111	Reserved																
OWL[1:0]	Output Word Length. These bits set the word length of the output data-word. All bits following the LSB are set to 0.																
	<table border="1"> <thead> <tr> <th>OWL[1:0]</th> <th>Setting</th> </tr> </thead> <tbody> <tr> <td>00</td> <td>24 bits</td> </tr> <tr> <td>01</td> <td>20 bits</td> </tr> <tr> <td>10</td> <td>16 bits</td> </tr> <tr> <td>11</td> <td>Reserved</td> </tr> </tbody> </table>	OWL[1:0]	Setting	00	24 bits	01	20 bits	10	16 bits	11	Reserved						
OWL[1:0]	Setting																
00	24 bits																
01	20 bits																
10	16 bits																
11	Reserved																

2079 (0x081F)—SERIAL INPUT CONTROL REGISTER

Table 49. Serial Input Control Register Bit Map

D7	D6	D5	D4	D3	D2	D1	D0	Default
0	0	0	ILP	IBP	M2	M1	M0	0x00

Table 50.

Bit Name	Description																		
ILP	INPUT_LRCLK Polarity. When this bit is set to 0, the left-channel data on the SDATA_INx pins is clocked when INPUT_LRCLK is low and the right-channel data is clocked when INPUT_LRCLK is high. When this bit is set to 1, the clocking of these channels is reversed. In TDM mode when this bit is set to 0, data is clocked in, starting with the next appropriate BCLK edge (set in Bit 3 of this register) after a falling edge on the INPUT_LRCLK pin. When this bit is set to 1 and the device is running in TDM mode, the input data is valid on the BCLK edge after a rising edge on the word clock (INPUT_LRCLK). INPUT_LRCLK can also operate with a pulse input, rather than a clock. In this case, the first edge of the pulse is used by the ADAU1701 to start the data frame. When this polarity bit is set to 0, a low pulse should be used; when the bit is set to 1, a high pulse should be used.																		
IBP	INPUT_BCLK Polarity. This bit controls on which edge of the bit clock the input data changes and on which edge it is clocked. Data changes on the falling edge of INPUT_BCLK when this bit is set to 0 and on the rising edge when this bit is set at 1.																		
M[2:0]	<p>Serial Input Mode. These two bits control the data format that the input port expects to receive. Bit 3 and Bit 4 of this control register override the settings of Bits[2:0]; therefore, all four bits must be changed together for proper operation in some modes. The clock diagrams for these modes are shown in Figure 32, Figure 33, and Figure 34. Note that for left-justified and right-justified modes, the LRCLK polarity is high and then low, which is the opposite of the default setting for ILP.</p> <p>When these bits are set to accept a TDM input, the ADAU1701 data starts after the edge defined by ILP. The ADAU1701 TDM data stream should be input on Pin SDATA_IN0. Figure 35 shows a TDM stream with a high-to-low triggered LRCLK and data changing on the falling edge of the BCLK. The ADAU1701 expects the MSB of each data slot to be delayed by one BCLK from the beginning of the slot, as it would in stereo I²S format. In TDM mode, Channel 0 to Channel 3 are in the first half of the frame, and Channel 4 to Channel 7 are in the second half. Figure 36 shows an example of a TDM stream running with a pulse word clock, which is used to interface to ADI codecs in auxiliary mode. To work in this mode with either the input or output serial ports, set the ADAU1701 to begin the frame on the rising edge of LRCLK, to change data on the falling edge of BCLK, and to delay the MSB position from the start of the word clock by one BCLK.</p> <table border="1"> <thead> <tr> <th>M[2:0]</th> <th>Setting</th> </tr> </thead> <tbody> <tr> <td>000</td> <td>I²S</td> </tr> <tr> <td>001</td> <td>Left-justified</td> </tr> <tr> <td>010</td> <td>TDM</td> </tr> <tr> <td>011</td> <td>Right-justified, 24 bits</td> </tr> <tr> <td>100</td> <td>Right-justified, 20 bits</td> </tr> <tr> <td>101</td> <td>Right-justified, 18 bits</td> </tr> <tr> <td>110</td> <td>Right-justified, 16 bits</td> </tr> <tr> <td>111</td> <td>Reserved</td> </tr> </tbody> </table>	M[2:0]	Setting	000	I ² S	001	Left-justified	010	TDM	011	Right-justified, 24 bits	100	Right-justified, 20 bits	101	Right-justified, 18 bits	110	Right-justified, 16 bits	111	Reserved
M[2:0]	Setting																		
000	I ² S																		
001	Left-justified																		
010	TDM																		
011	Right-justified, 24 bits																		
100	Right-justified, 20 bits																		
101	Right-justified, 18 bits																		
110	Right-justified, 16 bits																		
111	Reserved																		

ADAU1701

2080 TO 2081 (0x0820 TO 0x0821)— MULTIPURPOSE PIN CONFIGURATION REGISTERS

Each multipurpose pin can be set to different functions from these registers (2080 to 2081). The two 3-byte registers are broken up into 12 4-bit (nibble) sections that each control a

different MP pin. Table 53 lists the function of each nibble setting within the MP pin configuration registers. The MSB of each pin's 4-bit configuration inverts the input to or output from the pin. The internal pull-up resistor (approximately 10 kΩ) of each MP pin is enabled when it is set as a digital input (either a GPIO input or a serial data port input).

Table 51. Register 2080 Bit Map

D15	D14	D13	D12	D11	D10	D9	D8	D23	D22	D21	D20	D19	D18	D17	D16	Default
								D7	D6	D5	D4	D3	D2	D1	D0	
MP33	MP32	MP31	MP30	MP23	MP22	MP21	MP20	MP53	MP52	MP51	MP50	MP43	MP42	MP41	MP40	0x00
								MP13	MP12	MP11	MP10	MP03	MP02	MP01	MP00	0x0000

Table 52. Register 2081 Bit Map

D15	D14	D13	D12	D11	D10	D9	D8	D23	D22	D21	D20	D19	D18	D17	D16	Default
								D7	D6	D5	D4	D3	D2	D1	D0	
MP93	MP92	MP91	MP90	MP83	MP82	MP81	MP80	MP113	MP112	MP111	MP110	MP103	MP102	MP101	MP100	0x00
								MP73	MP72	MP71	MP70	MP63	MP62	MP61	MP60	0x0000

Table 53.

Bit Name	Description
MPx[3:0]	Set the function of each multipurpose pin.
	MPx[3:0] Setting
	1111 Auxiliary ADC input (see Table 62)
	1110 Reserved
	1101 Reserved
	1100 Serial data port—inverted (see Table 64)
	1011 Open-collector output—inverted
	1010 GPIO output—inverted
	1001 GPIO input, no debounce—inverted
	1000 GPIO input, debounced—inverted
	0111 N/A
	0110 Reserved
	0101 Reserved
	0100 Serial data port (see Table 64)
	0011 Open-collector output
	0010 GPIO output
	0001 GPIO input, no debounce
	0000 GPIO input, debounced

2082 (0x0822)—AUXILIARY ADC AND POWER CONTROL

Table 54. Auxiliary ADC and Power Control Bit Map

D15	D14	D13	D12	D11	D10	D9	D8	D7	D6	D5	D4	D3	D2	D1	D0	Default
RSVD	RSVD	RSVD	RSVD	RSVD	RSVD	FIL1	FIL0	AAPD	VBPD	VRPD	RSVD	D0PD	D1PD	D2PD	D3PD	0x0000

Table 55.

Bit Name	Description	
FIL[1:0]	Auxiliary ADC filtering	
	FIL[1:0]	Setting
	00	4-bit hysteresis (12-bit level)
	01	5-bit hysteresis (12-bit level)
	10	Filter and hysteresis bypassed
	11	Low-pass filter bypassed
AAPD	ADC power-down (both ADCs)	
VBPD	Voltage reference buffer power-down	
VRPD	Voltage reference power-down	
D0PD	DAC0 power-down	
D1PD	DAC1 power-down	
D2PD	DAC2 power-down	
D3PD	DAC3 power-down	

2084 (0x0824)—AUXILIARY ADC ENABLE

Table 56. Auxiliary ADC Enable Bit Map

D15	D14	D13	D12	D11	D10	D9	D8	D7	D6	D5	D4	D3	D2	D1	D0	Default
AAEN	RSVD	RSVD	RSVD	RSVD	RSVD	RSVD	RSVD	RSVD	RSVD	RSVD	RSVD	RSVD	RSVD	RSVD	RSVD	0x0000

Table 57.

Bit Name	Description
AAEN	Enable the auxiliary ADC

2086 (0x0826)—OSCILLATOR POWER-DOWN

Table 58. Oscillator Power-Down Bit Map

D15	D14	D13	D12	D11	D10	D9	D8	D7	D6	D5	D4	D3	D2	D1	D0	Default
RSVD	RSVD	RSVD	RSVD	RSVD	RSVD	RSVD	RSVD	RSVD	RSVD	RSVD	RSVD	RSVD	OPD	RSVD	RSVD	0x0000

Table 59.

Bit Name	Description
OPD	Oscillator Power Down. Power down the oscillator.

ADAU1701

2087 (0x0827)—DAC SETUP

To properly initialize the DACs, Bits DS[1:0] in this register should be set to 01.

Table 60. DAC Setup Bit Map

D15	D14	D13	D12	D11	D10	D9	D8	D7	D6	D5	D4	D3	D2	D1	D0	Default
RSVD	RSVD	RSVD	RSVD	RSVD	RSVD	RSVD	RSVD	RSVD	RSVD	RSVD	RSVD	RSVD	RSVD	DS1	DS0	0x0000

Table 61.

Bit Name	Description	
DS[1:0]	DAC Setup.	
	DS[1:0]	Setting
	00	Reserved
	01	Initialize DACs
	10	Reserved
11	Reserved	

MULTIPURPOSE PINS

The ADAU1701 has 12 multipurpose (MP) pins that can be individually programmed to be used as serial data inputs, serial data outputs, digital control inputs/outputs to and from the SigmaDSP core, or inputs to the 4-channel auxiliary ADC. These pins allow the ADAU1701 to be used with external ADCs and DACs. They also use analog or digital inputs to control settings such as volume control, or use output digital signals to drive LED indicators. Every MP pin has an internal 15 kΩ pull-up resistor.

AUXILIARY ADC

The ADAU1701 has a 4-channel, auxiliary, 8-bit ADC that can be used in conjunction with a potentiometer to control volume, tone, or other parameter settings in the DSP program. Each of the four channels is sampled at the audio sampling frequency (f_s). Full-scale input on this ADC is 3.0 V, so the step size is approximately 12 mV (3.0 V/256 steps). The input resistance of the ADC is approximately 30 kΩ. Table 62 indicates which four MP pins are mapped to the four channels of the auxiliary ADC. The auxiliary ADC is enabled for those pins by writing 1111 to the appropriate portion of the multipurpose pin configuration registers.

The auxiliary ADC is turned on by setting the AAEN bit of the auxiliary ADC enable register (see Table 57).

Noise on the ADC input can cause the digital output to constantly change by a few LSBs. If the auxiliary ADC is used to control volume, this constant change causes small gain fluctuations. To avoid this, add a low-pass filter or hysteresis to the auxiliary ADC signal path by enabling either function in the auxiliary ADC and power control register (2082), as described in Table 55. The filter is enabled by default when the auxiliary ADC is enabled. When data is read from the auxiliary ADC registers, two bytes (12 bits of data, plus zero-padded LSBs) are available because of this filtering.

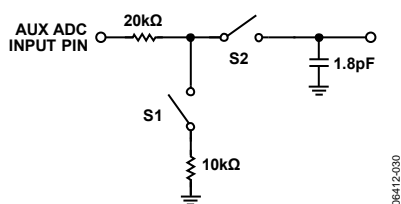

Figure 31. Auxiliary ADC Input Circuit

Figure 31 shows the input circuit for the auxiliary ADC. Switch S1 enables the auxiliary ADC and is set by Bit 15 of the auxiliary ADC enable register. The sampling switch, S2, operates at the audio sampling frequency.

The auxiliary ADC data registers can be written to directly after AACW in the DSP core control register has been set. In this mode, the voltages on the analog inputs are not written into the registers, but rather the data in the registers is written from the control port.

PVDD supplies the 3.3 V power for the auxiliary ADC analog input. The digital core of the auxiliary ADC is powered with the 1.8 V DVDD signal.

Table 62. Multipurpose Pin Auxiliary ADC Mapping

Multipurpose Pin	Function
MP0	N/A
MP1	N/A
MP2	ADC1
MP3	ADC2
MP4	N/A
MP5	N/A
MP6	N/A
MP7	N/A
MP8	ADC3
MP9	ADC0
MP10	N/A
MP11	N/A

GENERAL-PURPOSE INPUT/OUTPUT PINS

The general-purpose input/output (GPIO) pins can be used as either inputs or outputs. These pins are readable and can be set either through the control interface or directly by the SigmaDSP core. When set as inputs, these pins can be used with push-button switches or rotary encoders to control DSP program settings. Digital outputs can be used to drive LEDs or external logic to indicate the status of internal signals and control other devices. Examples of this use include indicating signal overload, signal present, and button press confirmation.

When set as an output, each pin can typically drive 2 mA. This is enough current to directly drive some high efficiency LEDs. Standard LEDs require about 20 mA of current and can be driven from a GPIO output with an external transistor or buffer. Because of issues that could arise from simultaneously driving or sinking a large current on many pins, care should be taken in the application design to avoid connecting high efficiency LEDs directly to many or all of the MPx pins. If many LEDs are required, use an external driver.

When the GPIO pins are set as open-collector outputs, they should be pulled up to a maximum voltage of 3.3 V (the voltage on IOVDD).

SERIAL DATA INPUT/OUTPUT PORTS

The flexible serial data input and output ports of the ADAU1701 can be set to accept or transmit data in 2-channel format or in an 8-channel TDM stream. Data is processed in twos complement, MSB-first format. The left-channel data field always precedes the right-channel data field in the 2-channel streams. In TDM mode, Slot 0 to Slot 3 are in the first half of the audio frame, and Slot 4 to Slot 7 are in the second half of the frame. TDM mode allows fewer multipurpose pins to be used, freeing more pins for other functions. The serial modes are set in the serial output and serial input control registers.

ADAU1701

The serial data clocks need to be synchronous with the ADAU1701 master clock input.

The input control register allows control of clock polarity and data input modes. The valid data formats are I²S, left-justified, right-justified (24-/20-/18-/16-bit), and 8-channel TDM. In all modes except for the right-justified modes, the serial port accepts an arbitrary number of bits up to a limit of 24. Extra bits do not cause an error, but they are truncated internally. Proper operation of the right-justified modes requires that there be exactly 64 BCLKs per audio frame. The TDM data is input on SDATA_IN0. The LRCLK in TDM mode can be input to the ADAU1701 either as a 50/50 duty cycle clock or as a bit-wide pulse.

In TDM mode, the ADAU1701 can be a master for 48 kHz and 96 kHz data, but not for 192 kHz data. Table 63 lists the modes in which the serial output port can function.

Table 63. Serial Output Port Master/Slave Mode Capabilities

f_s	2-Channel Modes (I²S, Left Justified, Right Justified)	8-Channel TDM
48 kHz	Master and slave	Master and slave
96 kHz	Master and slave	Master and slave
192 kHz	Master and slave	Slave only

The output control registers allow the user to control clock polarities, clock frequencies, clock types, and data format. In all modes except for the right-justified modes (MSB delayed by 8, 12, or 16 bits), the serial port accepts an arbitrary number of bits up to a limit of 24. Extra bits do not cause an error, but are truncated internally. Proper operation of the right-justified modes requires the LSB to align with the edge of the LRCLK. The default settings of all serial port control registers correspond to 2-channel I²S mode. All register settings apply to both master and slave modes unless otherwise noted.

The function of each multipurpose pin in serial data port mode is shown in Table 64. Pin MP0 to Pin MP5 support digital data input to the ADAU1701, and Pin MP6 to Pin MP11 handle digital data output from the DSP. The configuration of the serial data

Table 65. Data Format Configurations

Format	LRCLK Polarity	LRCLK Type	BCLK Polarity	MSB Position
I ² S (Figure 32)	Frame begins on falling edge	Clock	Data changes on falling edge	Delayed from LRCLK edge by 1 BCLK
Left-Justified (Figure 33)	Frame begins on rising edge	Clock	Data changes on falling edge	Aligned with LRCLK edge
Right-Justified (Figure 34)	Frame begins on rising edge	Clock	Data changes on falling edge	Delayed from LRCLK edge by 8, 12, or 16 BCLKs
TDM with Clock (Figure 35)	Frame begins on falling edge	Clock	Data changes on falling edge	Delayed from start of word clock by 1 BCLK
TDM with Pulse (Figure 36)	Frame begins on rising edge	Pulse	Data changes on falling edge	Delayed from start of word clock by 1 BCLK

input port is set in the serial input control register (Table 50), and the configuration of the corresponding output port is controlled with the serial output control register (Table 48). The clocks of the input port function only as slaves, whereas the output port clocks can be set to function as either masters or slaves. The INPUT_LRCLK (MP4) and INPUT_BCLK (MP5) pins are used to clock the SDATA_INx (MP0 to MP3) signals, and the OUTPUT_LRCLK (MP10) and OUTPUT_BCLK (MP11) pins are used to clock the SDATA_OUTx (MP6 to MP9) signals.

If an external ADC is connected as a slave to the ADAU1701, use both the input and output port clocks. The OUTPUT_LRCLK (MP10) and OUTPUT_BCLK (MP11) pins must be set to master mode and connected externally to the INPUT_LRCLK (MP4) and INPUT_BCLK (MP5) pins as well as to the external ADC clock input pins. The data is output from the external ADC into the SigmaDSP on one of the four SDATA_INx pins (MP0 to MP3).

Connections to an external DAC are handled exclusively with the output port pins. The OUTPUT_LRCLK and OUTPUT_BCLK pins can be set to function as either masters or slaves, and the SDATA_OUTx pins are used to output data from the SigmaDSP to the external DAC.

Table 65 describes the proper configurations for standard audio data formats.

Table 64. Multipurpose Pin Serial Data Port Functions

Multipurpose Pin	Function
MP0	SDATA_IN0/TDM_IN
MP1	SDATA_IN1
MP2	SDATA_IN2
MP3	SDATA_IN3
MP4	INPUT_LRCLK (slave only)
MP5	INPUT_BCLK (slave only)
MP6	SDATA_OUT0/TDM_OUT
MP7	SDATA_OUT1
MP8	SDATA_OUT2
MP9	SDATA_OUT3
MP10	OUTPUT_LRCLK (master or slave)
MP11	OUTPUT_BCLK (master or slave)

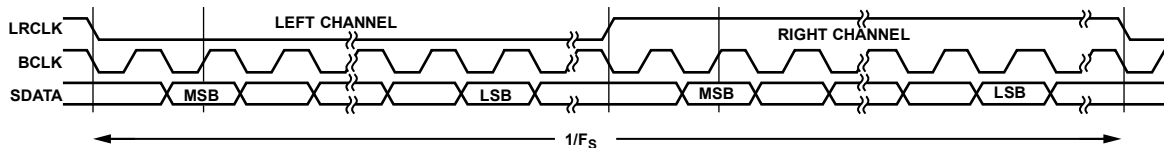

Figure 32. I²S Mode—16 Bits to 24 Bits per Channel

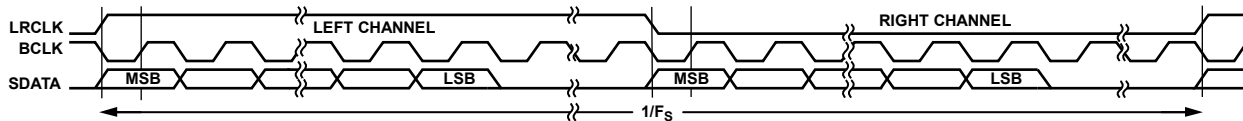

Figure 33. Left-Justified Mode—16 Bits to 24 Bits per Channel

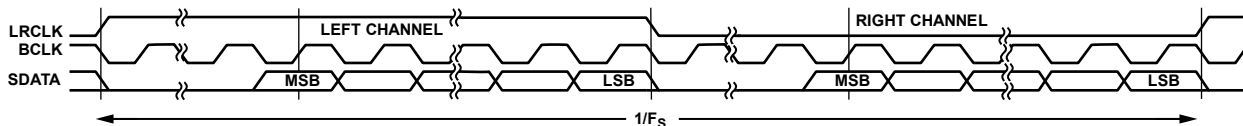

Figure 34. Right-Justified Mode—16 Bits to 24 Bits per Channel

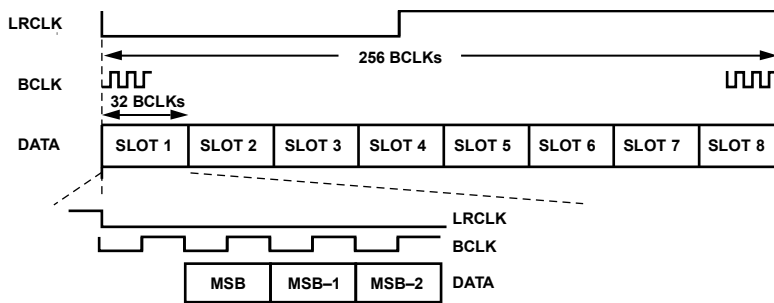

Figure 35. TDM Mode

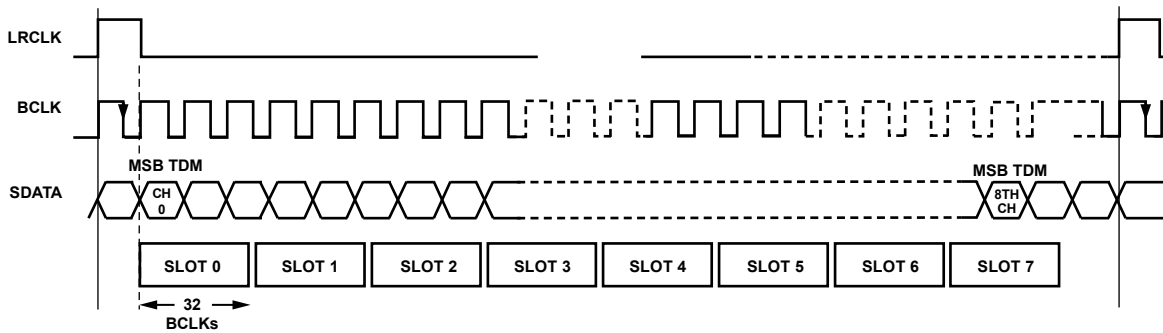

Figure 36. TDM Mode with Pulse Word Clock

LAYOUT RECOMMENDATIONS

PARTS PLACEMENT

The ADC input voltage-to-current resistors and the ADC current set resistor should be placed as close as possible to the 2, 3, and 4 input pins.

All 100 nF bypass capacitors, which are recommended for every analog, digital, and PLL power/ground pair, should be placed as close as possible to the ADAU1701. The 3.3 V and 1.8 V signals on the board should also each be bypassed with a single bulk capacitor (10 μ F to 47 μ F).

All traces in the crystal oscillator circuit (Figure 14) should be kept as short as possible to minimize stray capacitance. In addition, avoid long board traces connected to any of these components because such traces may affect crystal startup and operation.

GROUNDING

A single ground plane should be used in the application layout. Components in an analog signal path should be placed away from digital signals.

TYPICAL APPLICATION SCHEMATICS

SELF-BOOT MODE

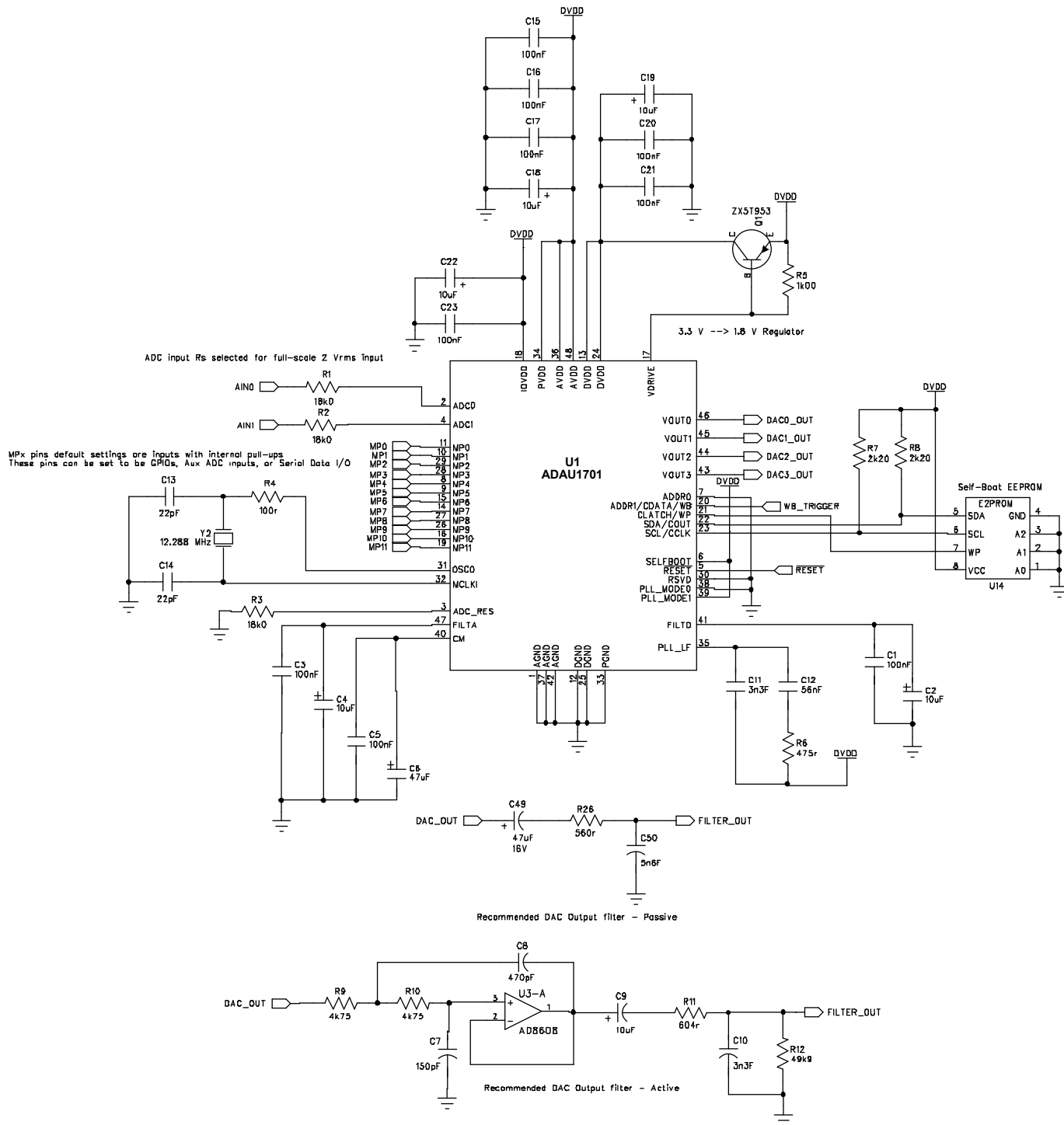

Figure 37. Self-Boot Mode Schematic

ADAU1701

I²C CONTROL

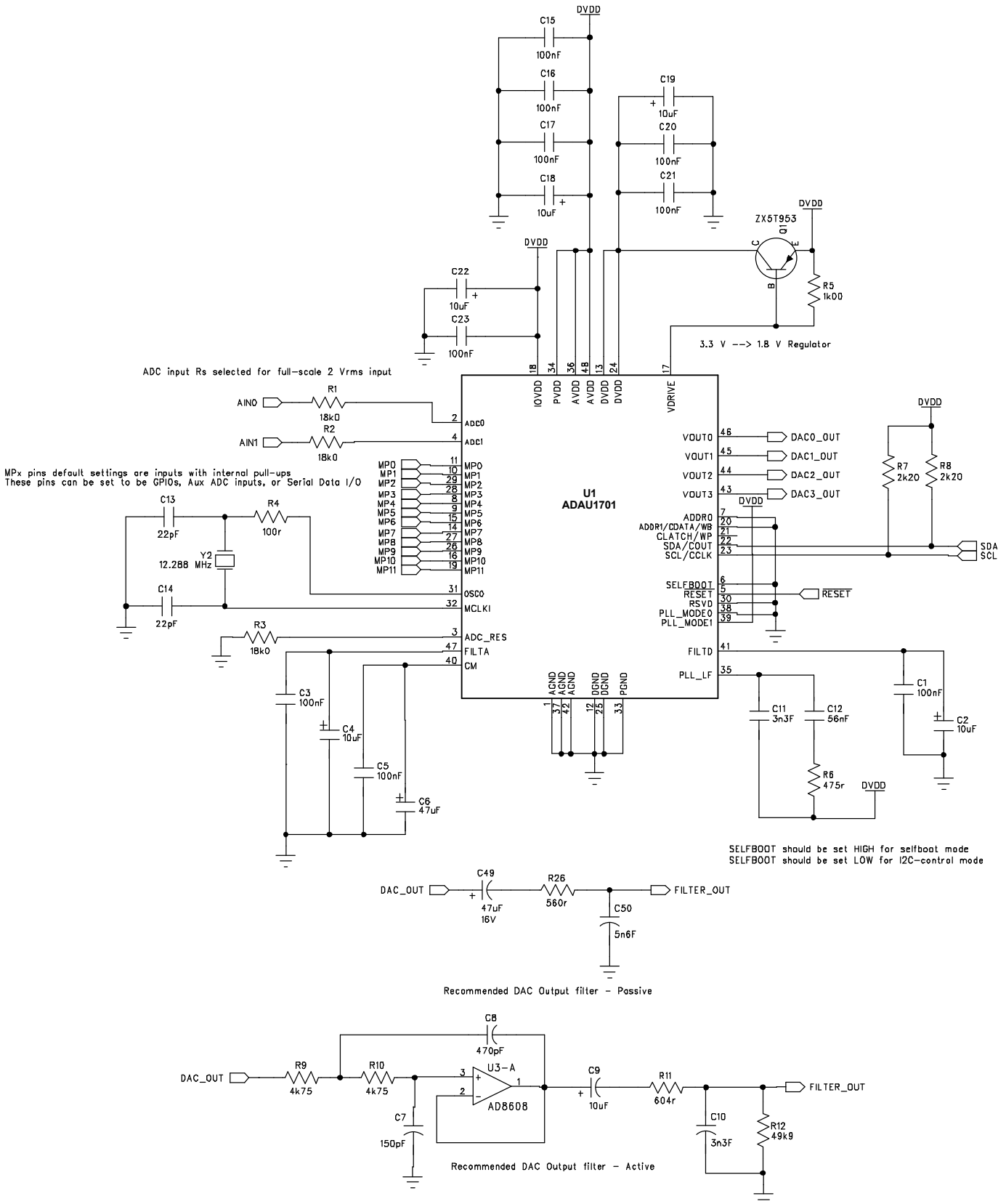

Figure 38. I²C Control Schematic

SPI CONTROL

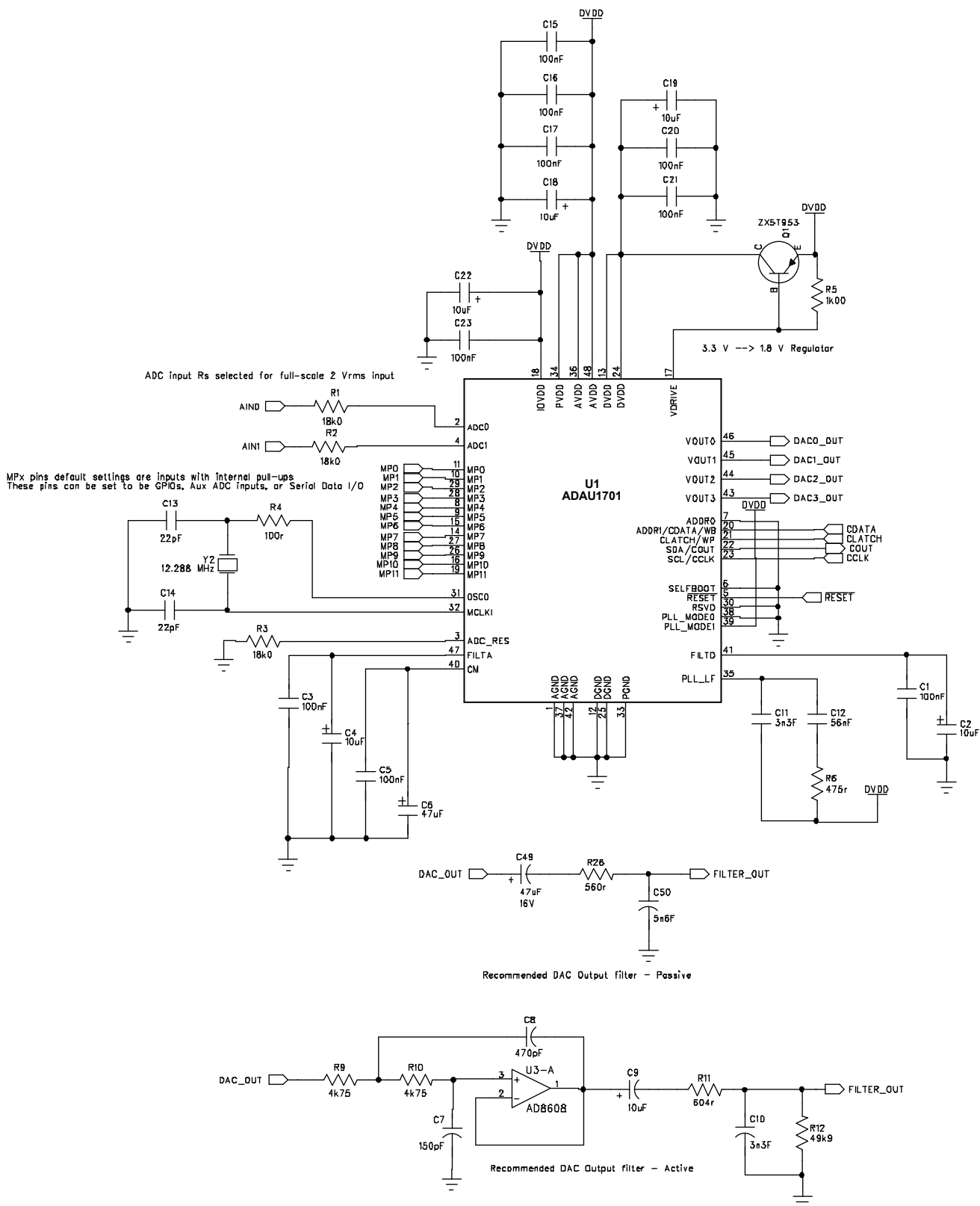
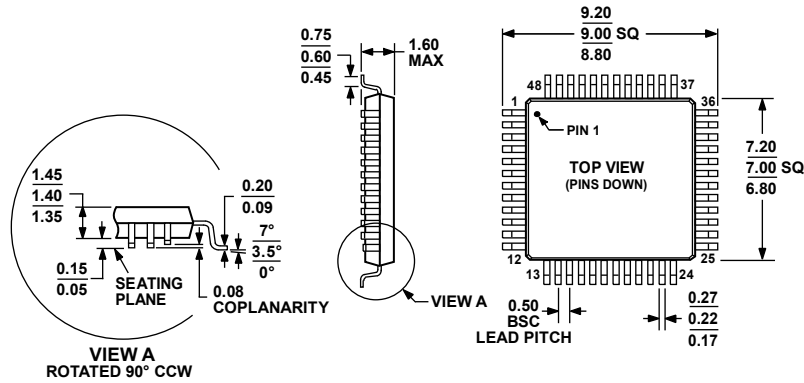

Figure 39. SPI Control Schematic

OUTLINE DIMENSIONS



COMPLIANT TO JEDEC STANDARDS MS-026-BBC

Figure 40. 48-Lead Low-Profile Quad Flat Package [LQFP]
(ST-48)

Dimensions shown in millimeters

061706-A

ORDERING GUIDE

Model ¹	Temperature Range	Package Description	Package Option
ADAU1701JSTZ	0°C to +70°C	48-Lead LQFP	ST-48
ADAU1701JSTZ-RL	0°C to +70°C	48-Lead LQFP in 13" Tape and Reel	ST-48
EVAL-ADAU1401EBZ		Evaluation Board	
EVAL-ADAU1701MINIZ		Evaluation Board	

¹ Z = RoHS Compliant Part.



**Стандарт
Электрон
Связь**

Мы молодая и активно развивающаяся компания в области поставок электронных компонентов. Мы поставляем электронные компоненты отечественного и импортного производства напрямую от производителей и с крупнейших складов мира.

Благодаря сотрудничеству с мировыми поставщиками мы осуществляем комплексные и плановые поставки широчайшего спектра электронных компонентов.

Собственная эффективная логистика и склад в обеспечивает надежную поставку продукции в точно указанные сроки по всей России.

Мы осуществляем техническую поддержку нашим клиентам и предпродажную проверку качества продукции. На все поставляемые продукты мы предоставляем гарантию .

Осуществляем поставки продукции под контролем ВП МО РФ на предприятия военно-промышленного комплекса России , а также работаем в рамках 275 ФЗ с открытием отдельных счетов в уполномоченном банке. Система менеджмента качества компании соответствует требованиям ГОСТ ISO 9001.

Минимальные сроки поставки, гибкие цены, неограниченный ассортимент и индивидуальный подход к клиентам являются основой для выстраивания долгосрочного и эффективного сотрудничества с предприятиями радиоэлектронной промышленности, предприятиями ВПК и научно-исследовательскими институтами России.

С нами вы становитесь еще успешнее!

Наши контакты:

Телефон: +7 812 627 14 35

Электронная почта: sales@st-electron.ru

Адрес: 198099, Санкт-Петербург,
Промышленная ул, дом № 19, литера Н,
помещение 100-Н Офис 331