

Bridgetek Pte Ltd

Datasheet

MM900EVxB Development Module

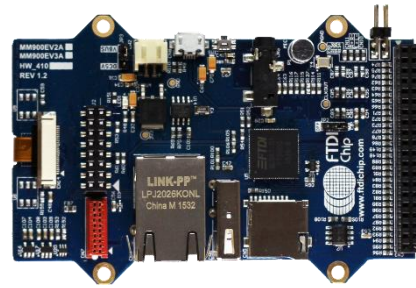

FT90X Family is a General Purpose 32-bit Microcontroller

1 Introduction

The MM900EVxB Series is a development module for Bridgetek's 32-bit high performance FT90X Revision C Microcontroller family, which is used to develop and demonstrate the functionality of the FT90X Embedded Microcontroller.

These modules apply to home security systems, home automation systems, USB capability products, embedded multimedia application and other industrial control systems.

There are 3 development modules for selection:

- MM900EV1B, without VGA camera module.
- MM900EV2B, with front facing VGA camera module and two RGB LEDs.
- MM900EV3B, with rear facing VGA camera module and two RGB LEDs.

1.1 Features

For a full list of the FT90X features refer to the [FT90X datasheet](#).

In addition, the MM900EVxB series has the following features:

- FT900 Revision C 100-pin QFN package microcontroller.
- RJ45 with built in magnetic for 10/100Mbps Ethernet transfer.
- Micro SD card socket support.
- A Standard USB Type A connector to support USB device connection.
- A Micro-B USB for connecting to a USB host or providing a power supply over USB for the board.
- Audio codec embedded on board with a microphone input, 3.5mm headphone jack and speakers stereo output.
- 2x8 pins 2.54mm pitch dual entry female header and 16 pins 0.5mm pitch FFC/FPC connectors for SPI master to support LCD display modules including Bridgetek's [EVE 2 modules](#).
- 2x5 pins 1.27mm pitch female Micro-Match connector for software download and debug.
- 2x20 pins 2.54mm pitch female header support for external feature expansions.
- Internal RTC with coin cell battery support.
- 24 pins 0.5mm pitch camera connector and two RGB LEDs (MM900EV2B/3B modules).
- +5V alternative power supply DC connector.
- Hardware Reset button provided.

Neither the whole nor any part of the information contained in, or the product described in this manual, may be adapted or reproduced in any material or electronic form without the prior written consent of the copyright holder. This product and its documentation are supplied on an as-is basis and no warranty as to their suitability for any particular purpose is either made or implied. Bridgetek Pte Ltd will not accept any claim for damages howsoever arising as a result of use or failure of this product. Your statutory rights are not affected. This product or any variant of it is not intended for use in any medical appliance, device or system in which the failure of the product might reasonably be expected to result in personal injury. This document provides preliminary information that may be subject to change without notice. No freedom to use patents or other intellectual property rights is implied by the publication of this document. Bridgetek Pte Ltd, 178 Paya Lebar Road, #07-03, Singapore 409030. Singapore Registered Company Number: 201542387H

2 Ordering Information

Part No.	Description
MM900EV1B	FT90X Revision C module, a 32-bit FT32 microcontroller with 256kB flash memory, 64kB data RAM and 256kB program memory embedded. 10/100Mbps Ethernet, SD3.0, USB2.0 Host and Device, Audio codec, several interface pin headers and connectors included. Without camera.
MM900EV2B	FT90X Revision C module, a 32-bit FT32 microcontroller with 256kB flash memory, 64kB data RAM and 256kB program memory embedded. 10/100Mbps Ethernet, SD3.0, USB2.0 Host and Device, Audio codec, several interface pin headers and connectors included. With front facing camera and two RGB LEDs.
MM900EV3B	FT90X Revision C module, a 32-bit FT32 microcontroller with 256kB flash memory, 64kB data RAM and 256kB program memory embedded. 10/100Mbps Ethernet, SD3.0, USB2.0 Host and Device, Audio codec, several interface pin headers and connectors included. With rear facing camera and two RGB LEDs.

Table 2-1 – Ordering information

Notes: MM900EV2B/3B modules will be released in the near future, see www.brtchip.com for more information

3 Program Support

Example applications are provided for MM900EVxB modules by Bridgetek.

The following documents provide further details for software development.

Other relevant documents and examples exist so please see the [Bridgetek website](#) for further information.

[AN 324 FT900 User Manual](#) for system registers information.

[AN 365 FT900 API Programmers Manual](#) for using FT90x Peripheral Driver Library.

[AN 360 FT90X Example Applications](#) for some simple example applications.

[BRT AN 019 Migration Guide](#) Moving From FT90x Revision B to Revision C

[FT90X Software Examples](#) and [FT9XX Software Examples](#) tier 2 examples.

Table of Contents

1	Introduction	1
1.1	Features.....	1
2	Ordering Information	2
3	Program Support.....	3
4	Board Layout.....	6
4.1	Power Supply	7
4.2	Microcontroller.....	8
4.3	Micro SD Connector.....	9
4.4	USB Connector	9
4.5	10/100Mbps Ethernet Connector	11
4.6	Programmer Interface	12
4.6.1	CN7 – 10-pin Micro-Match Program Interface Signals.....	12
4.7	SPI Master Interface.....	14
4.7.1	J2 – 16-pin Dual Entry Header, SPI Master and Control Signals	14
4.7.2	CN12 – 16-pin FPC/FFC connector	15
4.8	Audio codec	16
4.8.1	Microphone Input	16
4.8.2	Audio Output	17
4.9	Camera connector	18
4.10	RGB LEDs	19
4.11	RTC	20
4.12	External I/O Bus.....	21
5	Board Schematic	24
6	Mechanical Dimensions	28
6.1	MM900EV1B PCB Dimensions.....	28
6.2	MM900EV2B/3B PCB Dimensions.....	29
7	Contact Information.....	30
Appendix A - References		33
Document References		33

Acronyms and Abbreviations	33
Appendix B - List of Figures and Tables	35
List of Figures	35
List of Tables	36
Appendix C – Revision History	37

4 Board Layout

The MM900EV1B development board is a 55 mm x 85 mm (Not including the 4 mounting holes) six-layer printed circuit board. The layout is as shown in Figure 4-1.

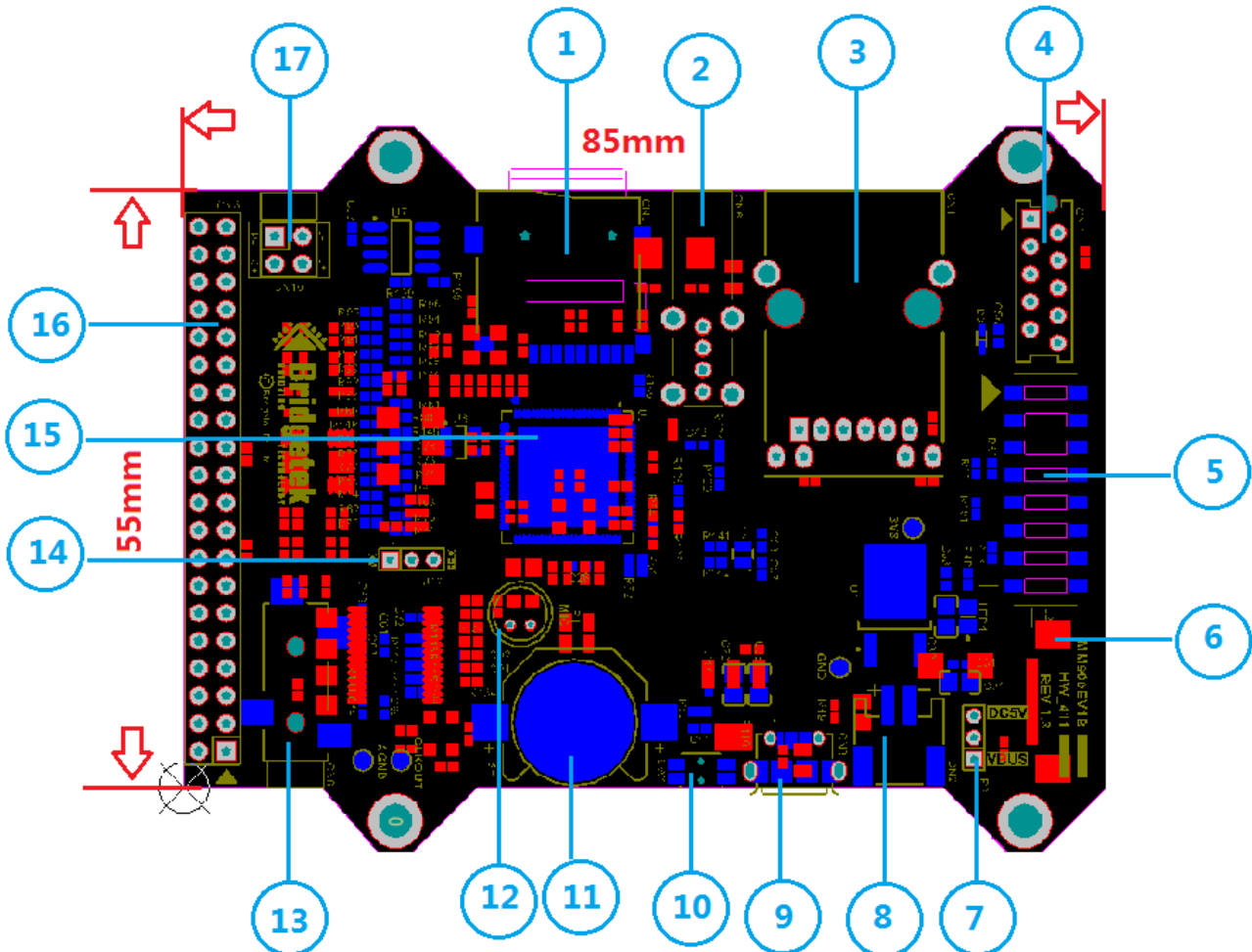

Figure 4-1 – MM900EV1B Board Layout

Key Features: (For all MM900EVxB series boards)

- | | |
|--------------------------------------|--|
| 1. Micro SD card socket | 10. H/W Reset button |
| 2. USB Standard A vertical connector | 11. Coin Cell battery holder |
| 3. Ethernet port | 12. Microphone |
| 4. Program interface | 13. Headphone 3.5mm stereo jack |
| 5. Dual-entry SPI master pin header | 14. Audio output jumper |
| 6. SPI master FPC/FFC connector | 15. FT900 QFN Microcontroller |
| 7. Alternative power supply jumper | 16. External I/O bus female pin header |
| 8. DC power socket | 17. Two speakers pin header |
| 9. USB Micro-B connector | |

The MM900EV2B/3B development boards are 55 mm x 100 mm (not including the 4 mounting holes) six-layer printed circuit boards. The layout is as shown in Figure 4-2.

The MM900EV2B and MM900EV3B both use the same bare PCB as the only difference is the position of the camera.

The MM900EV2B is supplied with a front facing camera module which is inserted into **CN13** (24-pin FFC/FPC 0.5mm pitch, bottom contact connector) and has two configurable colour RGB LEDs fitted at **U8** and **U9**.

The MM900EV3B is supplied with a rear facing camera module which is inserted into **CN14** (24-pin FFC/FPC 0.5mm pitch, bottom contact connector) and has two configurable colour RGB LEDs fitted at **U18** and **U19**.

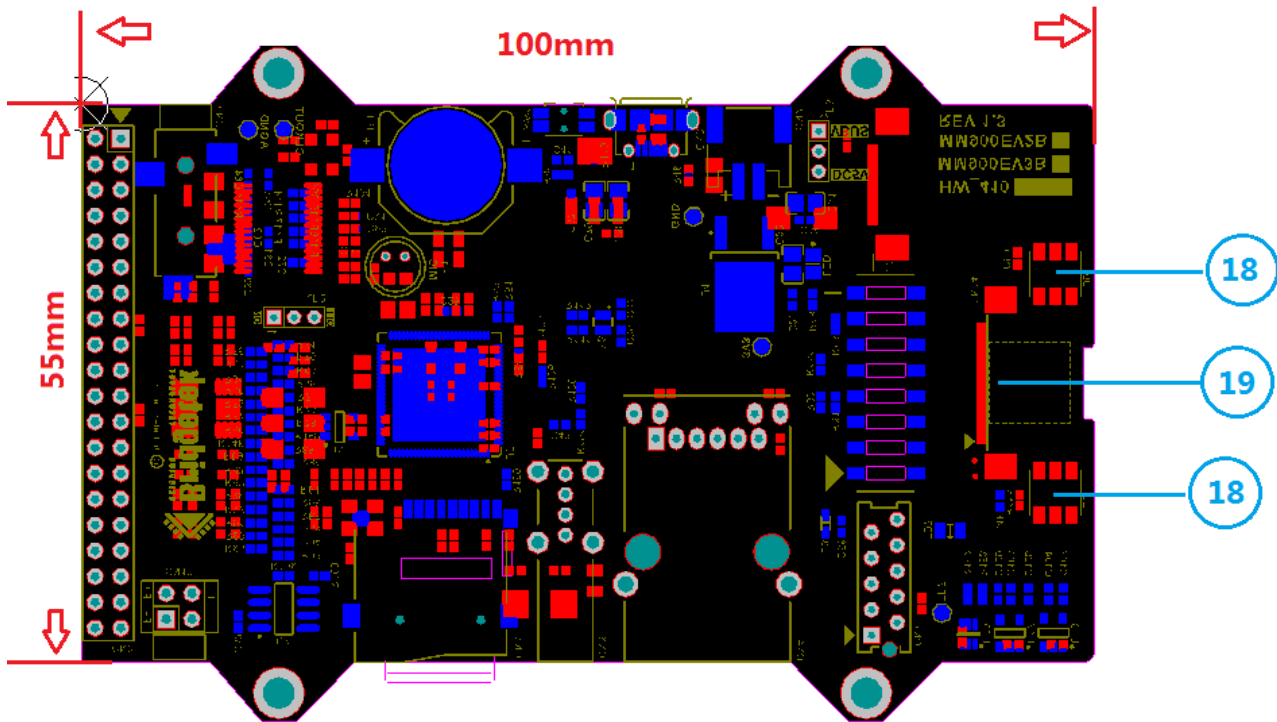

Figure 4-2 – MM900EV2B/3B Board Layout

Key Features: (For MM900EV2B/3B board only)

18. Two RGB LEDs

19. VGA camera module FPC/FFC connector

4.1 Power Supply

The MM900EVxB development boards provide optional power supply sources with **JP3** jumper:

1. 5V DC power supply, **CN2** right angle connector.
2. Via the USB Micro-B USB **CN8** port.

Pin No.	Name
1-2	USB VBUS power supply
2-3	5V DC power supply

Table 4-1 – JP3 Pinout

A red LED (LED1) will illuminate after the 5V power supply is applied. This supply will also drive a fixed 3.3V LDO regulator which will power to all peripherals of the FT900 microcontroller.

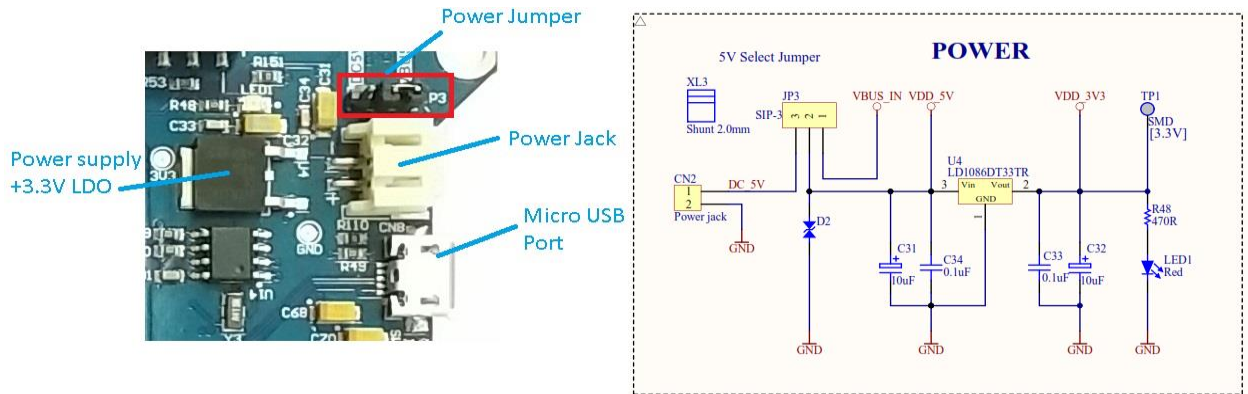

Figure 4-3 – Power supply

4.2 Microcontroller

The FT900 100-pin QFN microcontroller (U5) provided on the board belongs to the 32-bit FT90X Revision C Microcontroller family from Bridgetek. For details of the FT900 Microcontroller, refer to the [FT90X datasheet](#).



Figure 4-4 – FT900 Microcontroller

There are two crystals used on the MM900EVxB development boards. The 12MHz crystal is the primary system clock frequency supplying the FT900 IC, while the other 32.768 KHz oscillator is used by the on-chip Real Time Clock (RTC).

The FT900 IC on this board is operated with a single supply of 3.3V. The FT900 Core 1.2V (VOUT1) and Ethernet Regulator 1.2V (VOUT2) sources are unused. These power output pins have decoupling capacitors as specified in the datasheet.

4.3 Micro SD Connector

The FT900 Microcontroller has a SD3.0 controller to support different speed classes, physical sizes and capacities of Secure Digital (SD) cards. There is a Micro SD connector on the MM900EVxB development modules for inserting Micro SD cards (11 x15 x1.0 mm).

There are three standard capacity cards supported:

- Secure Digital (SD) standard – Up to 2GB SD memory card
- Secure Digital High Capacity (SDHC) standard – Over 2GB-32GB SDHC memory card
- Secure Digital extended Capacity (SDXC) standard – Over 32GB-2TB SDXC memory card

Standard class speeds 2, 4, 6, 10, and Ultra High Speed (UHS) classes U1 and U3 are all supported. The design of the physical interface supports 4-bit SD bus mode and card detection.

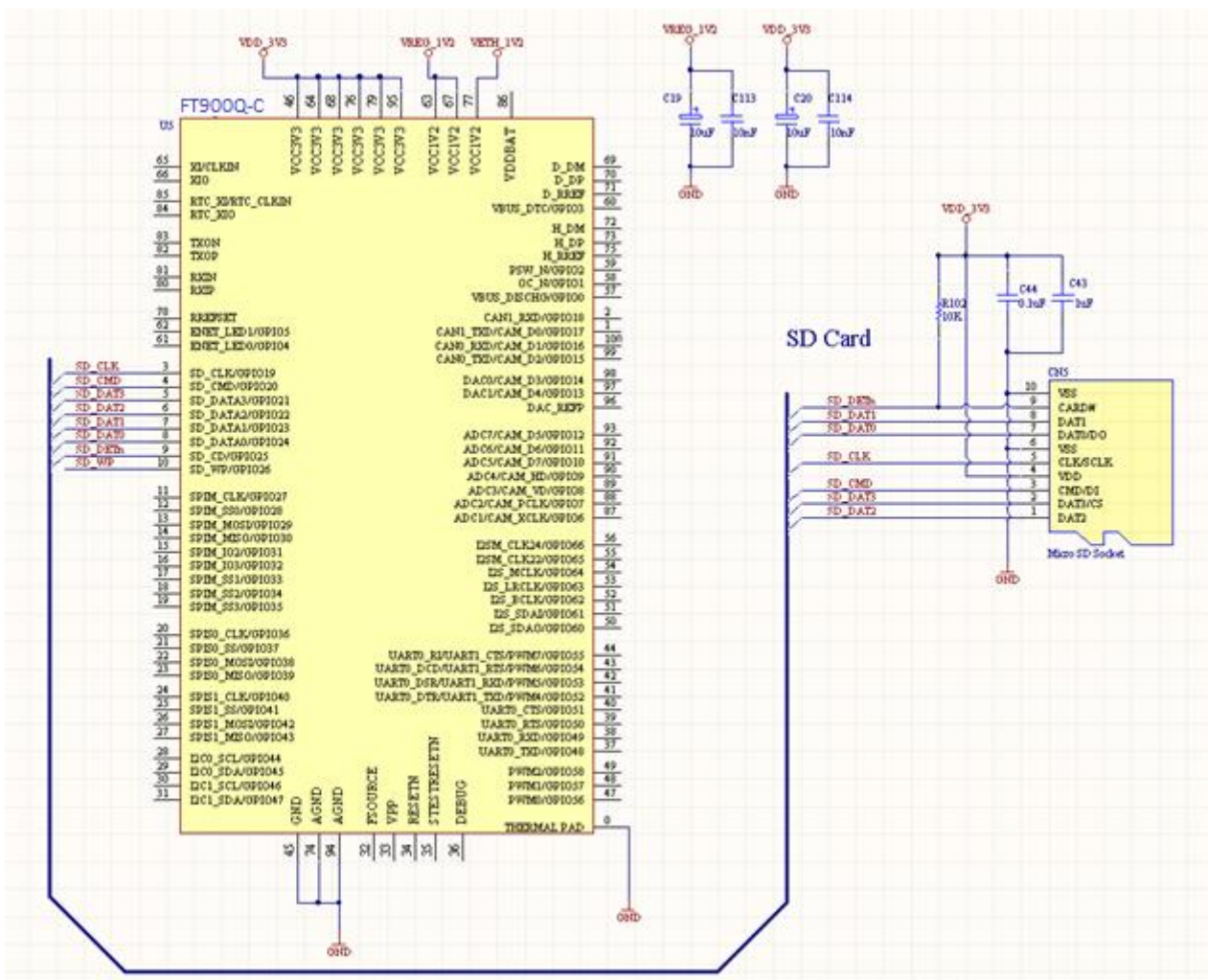

Figure 4-5 – Micro SD Connector

4.4 USB Connector

There are two USB connectors provided on the MM900EVxB series board. One **CN8** is a Micro-B type USB2.0 connector which is used for connecting to a USB host, while the other **CN6** is Standard-A type vertical USB2.0 connector which serves as a USB2.0 host connector.

The USB2.0 host port is an EHCI specification compatible port to support hi-speed, full-speed and low-speed data transfer with USB devices. There is also a power switch **U7** for the VBUS power supply which provides over current protection on board.

The USB differential impedance for DP and DM signals on the USB device and USB host ports is controlled via the PCB layout.

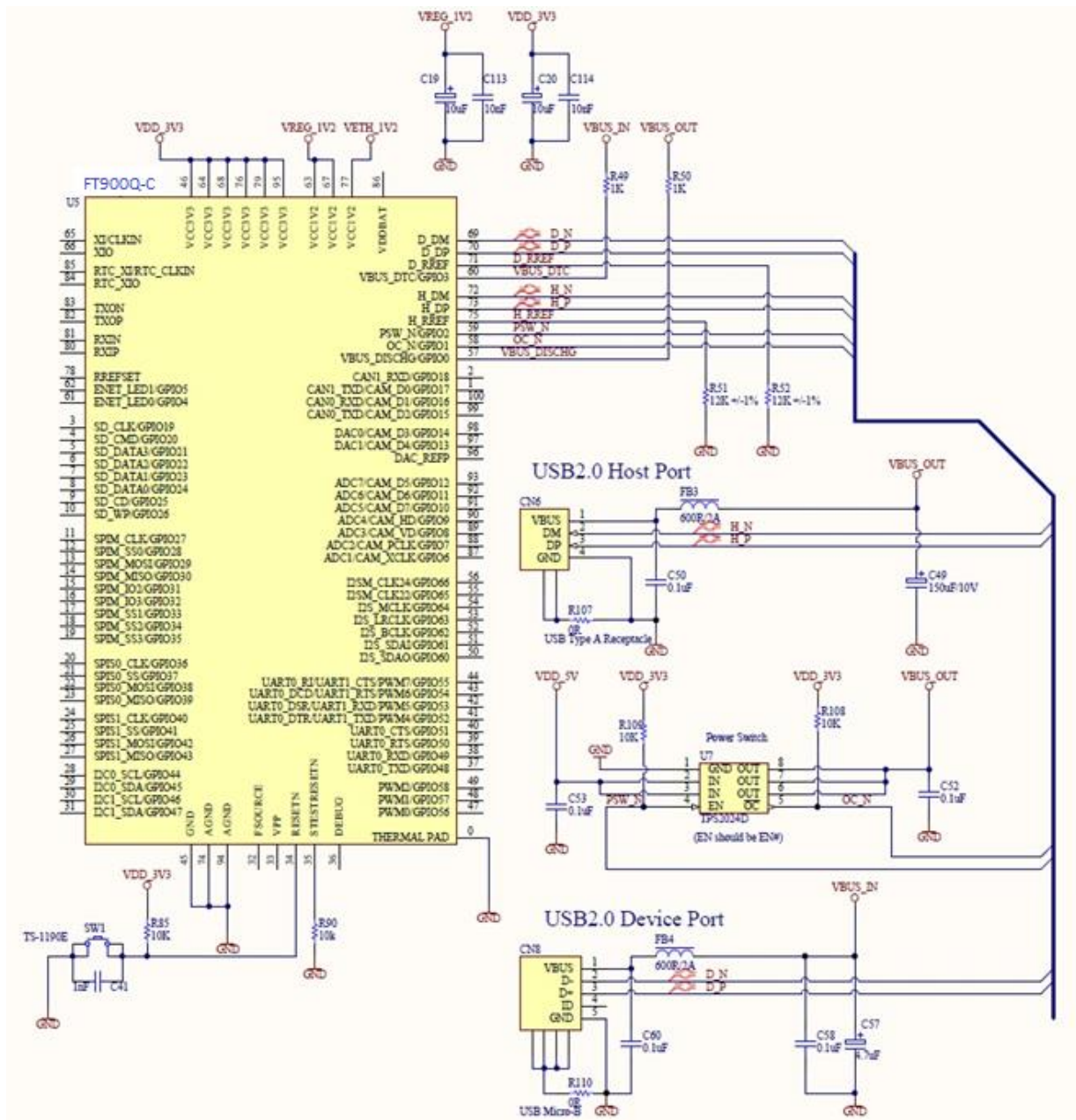

Figure 4-6 – USB Connectors

4.5 10/100Mbps Ethernet Connector

An RJ45 Ethernet Jack (**CN4**) with built in transformer (magnetics), status LEDs and shielding is provided for 10/100 BASE-T applications on the MM900EVxB development modules. The FT900 microcontroller has an IEEE802.3 specification compatible Ethernet interface, with integrated MAC and PHY, which provides standard communication with a network over Ethernet.

For signal integrity, Ethernet differential impedance is controlled on the MM900EVxB development board in the PCB layout. 50ohm +/-10% impedance of TX & RX signals to ground and 100ohm +/-10% differential impedance between TX_N and TX_P, or RX_N and RX_P.

MM900EVxB development modules provide a unique 48-bit MAC address for Ethernet applications, which can be accessed on the 256 EEPROM **U6** via I²C serial interface. This EEPROM stores a permanently write-protected MAC address in upper half of memory array.

Two status LEDs configured by software. See Table 4-2.

LEDs	Colour	Description
Left LED (LED1)	Green	Speed indicator: Green on – Operating as a 100Mbps connection. Green off – Operating as a 10Mbps connection.
Right LED (LED0)	Yellow	Link/Activity indicator: Blinking – There is activity on this port. Off – No link is established.

Table 4-2 – Ethernet LEDs

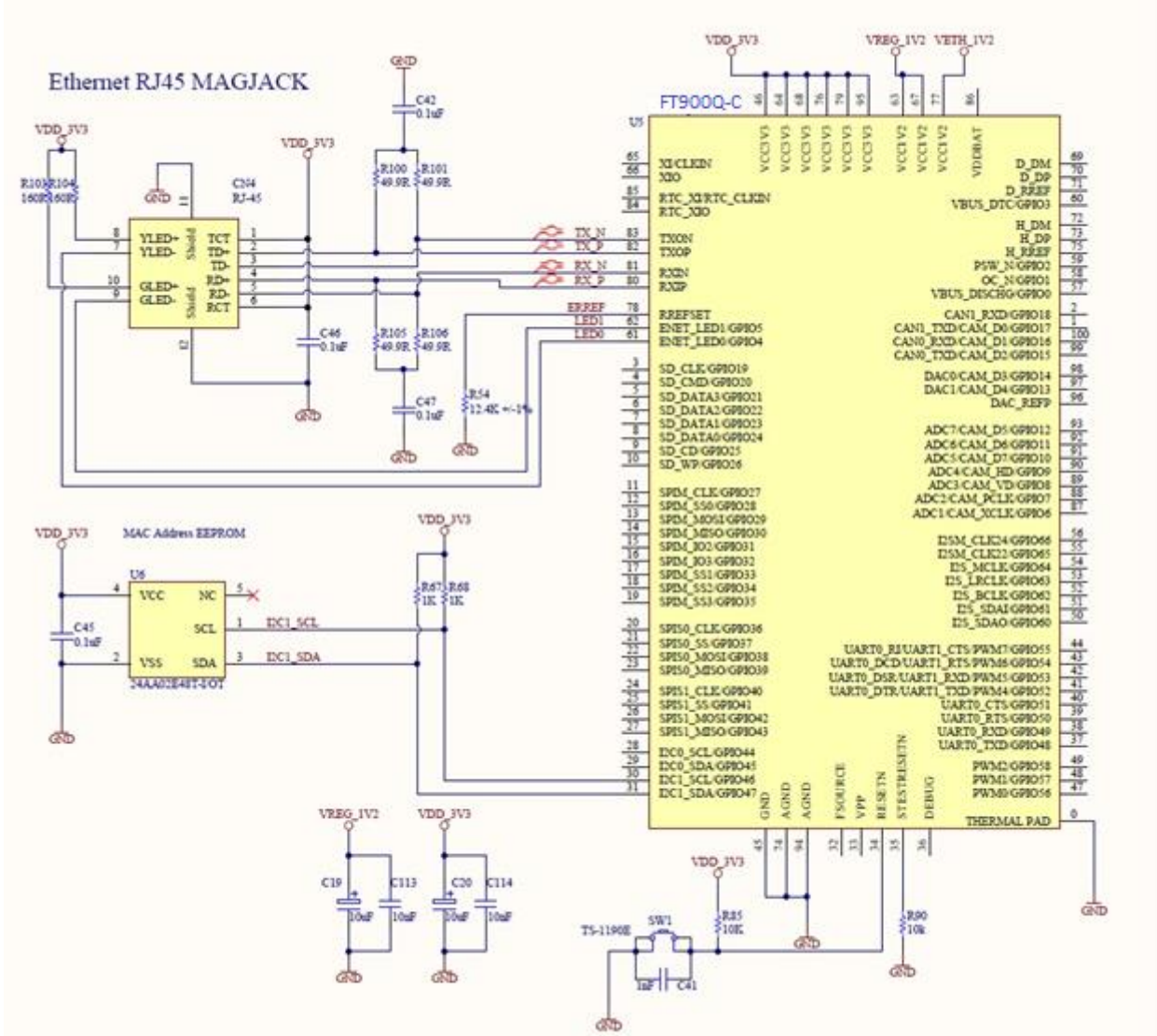

Pin No.	Name	Type	Description
3	SPI0_MOSI	I	SPI Slave 0 data input
4	SPI0_MISO	O	SPI Slave 0 data output
5	NC		No connection
6	NC		No connection
7	GND	P	Ground
8	DEBUG	I/O	FT90x One-Wire Interface
9	GDB_5V	P	External 5V power supply Reserved D3 Diode with external power supply.
10	RESETn	P	H/W Reset, active low

Table 4-3 – CN7 Pinout

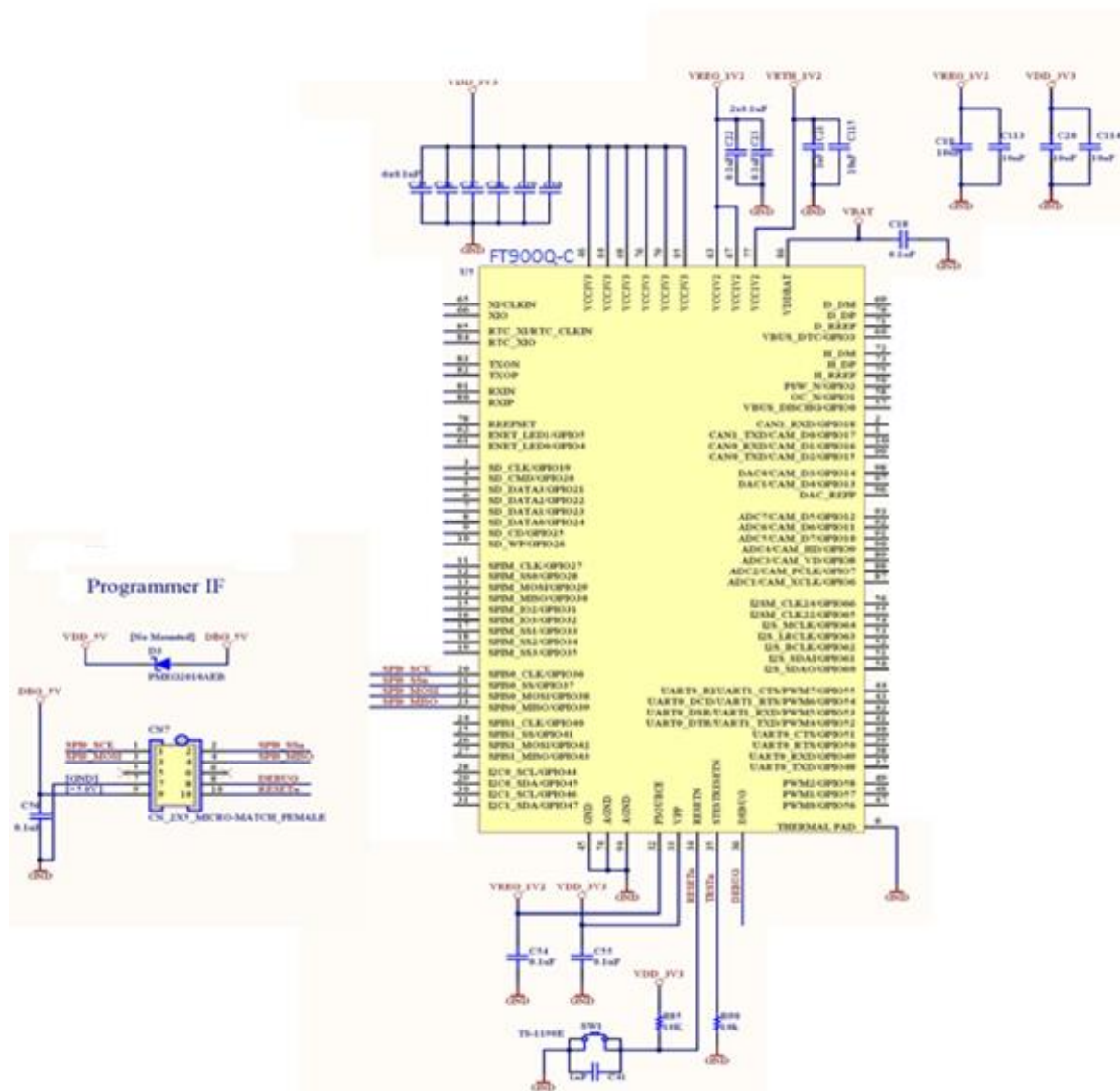

Figure 4-8 – Program Interface

4.7 SPI Master Interface

The FT900 microcontroller has a SPI master interface that supports single, dual and quad SPI data transfer modes. There are two alternative connectors for supporting different LCD display modules as SPI slave devices.

- The **J2** dual-entry 2x8 pins 2.54mm pitch, female header (Table 4-4) is designed for FT80x and FT81x Embedded Video Engine (EVE) family LCD display modules. The [EVE 2 modules](#) can connect directly to MM900EVxB development boards on the bottom side with a male pin header.
- The **CN12** 16 pins 0.5mm pitch, bottom contact FFC/FPC connector (Table 4-5) provides an alternative connection for LCD display modules that meet FT80x or FT81x chip technical specifications and use a 16-pin 0.5mm pitch flexible flat cable to link to the board.

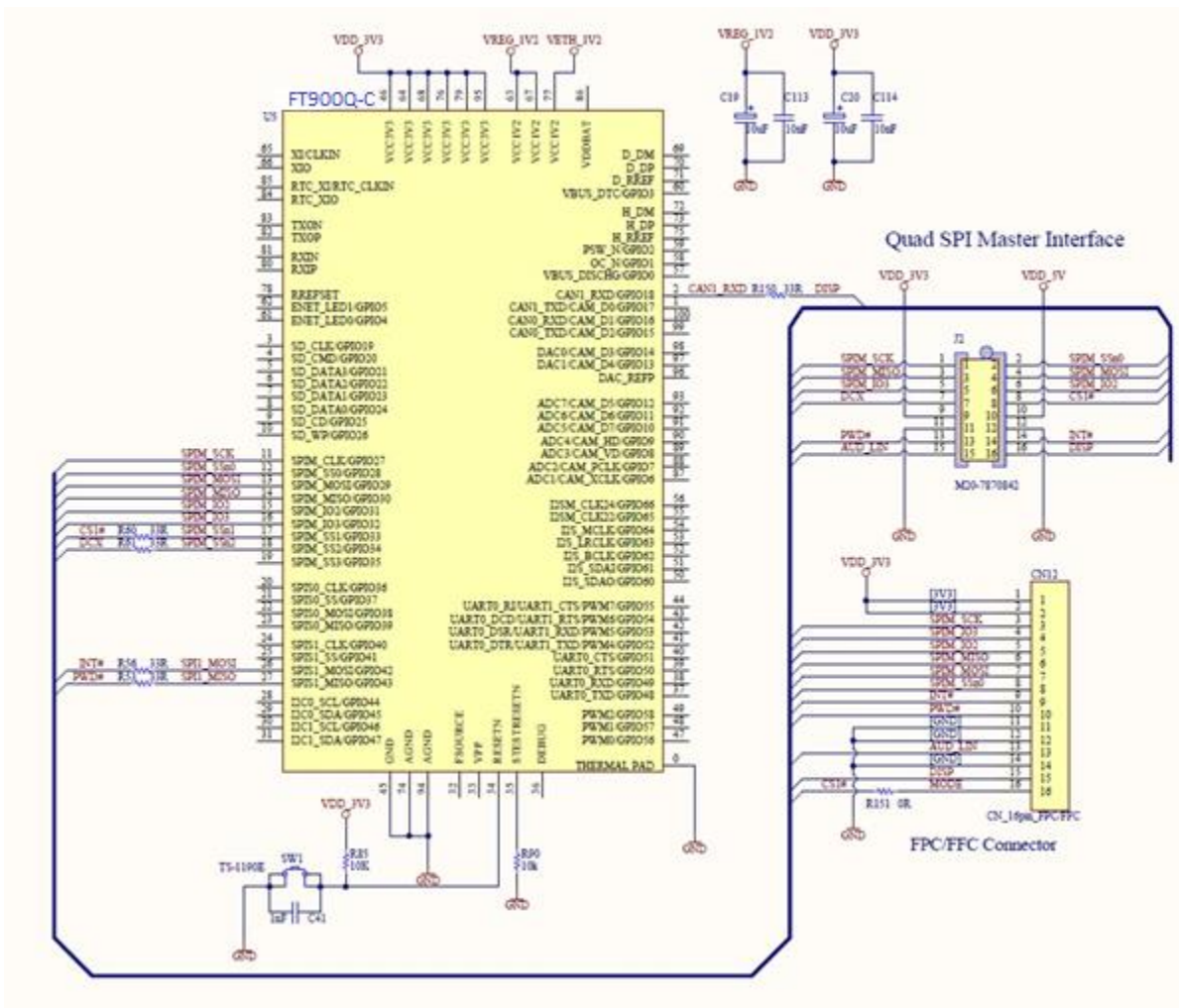

Figure 4-9 – SPI Master Interface

4.7.1 J2 – 16-pin Dual Entry Header, SPI Master and Control Signals

Pin No.	Name	Type	Description
1	SPIM_SCK	O	SPI Master clock output
2	SPIM_SS0	O	SPI Master chip select 0, active low
3	SPIM_MISO	I/O	SPI Master input, Slave output

Pin No.	Name	Type	Description
			Data 1 for Quad SPI
4	SPIM_MOSI	I/O	SPI Master output, Slave input Data 0 for Quad SPI
5	SPIM_IO3	I/O	General I/O, data 3 for Quad SPI
6	SPIM_IO2	I/O	General I/O, data 2 for Quad SPI
7	DCX	O	Data / command selection pin for LCD controller Low: Command High: Parameter
8	CS1#	O	SPI Master chip select 1, active low for LCD controller
9	VDD_3V3	P	3.3V power supply
10	VDD_5V	P	5V power supply
11	GND	P	Ground
12	GND	P	Ground
13	PWD#	O	FT80X power down control, active low
14	INT#	I	Interrupt input from FT80X, active low
15	AUD_LIN	I	Audio PWM input from FT80X
16	DISP	O	LCD display enable

Table 4-4 – J2 Pinout

4.7.2 CN12 – 16-pin FPC/FFC connector

Pin No.	Name	Type	Description
1,2	VDD_3V3	P	3.3V Power supply
3	SPIM_SCK	O	SPI Master clock output
4	SPIM_IO3	I/O	General I/O, data 3 for Quad SPI
5	SPIM_IO2	I/O	General I/O, data 2 for Quad SPI
6	SPIM_MISO	I/O	SPI Master input, Slave output Data 1 for Quad SPI
7	SPIM_MOSI	I/O	SPI Master output, Slave input Data 0 for Quad SPI
8	SPIM_SS0	O	SPI Master chip select 0, active low
9	INT#	I	Interrupt input from FT80X, active low
10	PWD#	O	FT80X power down control, active low
11,12,14	GND	P	Ground
13	AUD_LIN	I	Audio PWM input from FT80X
15	DISP	O	LCD display enable

Pin No.	Name	Type	Description
16	MODE	0	Serial interface selection for FT80X Low: SPI interface High: I2C interface

Table 4-5 – CN12 Pinout

4.8 Audio codec

A Cirrus Logic WM8731 Audio Codec device is included in the MM900EVxB development boards for multimedia functionality. It is a low power stereo codec with an integrated headphone driver, designed specifically for MP3 audio, speech player and recorder applications.

This codec device can provide the following audio performance:

- ADC SNR 90dB ('A' weighted) at 3.3V
- DAC SNR 100dB ('A' weighted) at 3.3V
- ADC and DAC sampling frequency range: 8KHz – 96KHz

The digital audio interface is a 4-line I²S interface which connects to the FT900 microcontroller and audio codec device. Both I²S devices can be registered to interface in master or slave mode. In this design, the WM8731 I²S interface has to be configured in the slave mode, while the FT900 microcontroller is in master mode and controls the sequence of the data and clocks on the digital audio interface.

4.8.1 Microphone Input

An electret condenser microphone (**P1**) provides an audio input on the MM900EVxB board (Figure 4-10), which gets a bias voltage from the audio codec device. This omnidirectional microphone works at frequencies from 100Hz to 20,000Hz. See Table 4-6 microphone specifications.

SPECIFICATIONS

directivity	omnidirectional	
sensitivity (S)	-44 ±3 dB	f = 1KHz, 1Pa 0dB = 1V/Pa
sensitivity reduction (ΔS-Vs)	-3 dB	f = 1KHz, 1Pa Vs = 2 ~ 1.5 V dc
operating voltage	2 V dc (standard), 10 V dc (max.)	
output impedance (Z _{out})	2.2 KΩ	f = 1KHz, 1Pa
operating frequency (f)	100 ~ 20,000 Hz	
current consumption (I _{DSS})	0.5 mA max.	Vs = 2 V dc RL = 2.2KΩ
signal to noise ratio (S/N)	56 dBA	f = 1KHz, 1Pa A-weighted
operating temperature	-20 ~ +70° C	
storage temperature	-20 ~ +70° C	
dimensions	ø6 x 5 mm	
weight	0.30 g max.	
material	Al	
terminal	pin type (Au plating, hand soldering only)	
RoHS	yes	

Table 4-6 – P1 Microphone Specifications

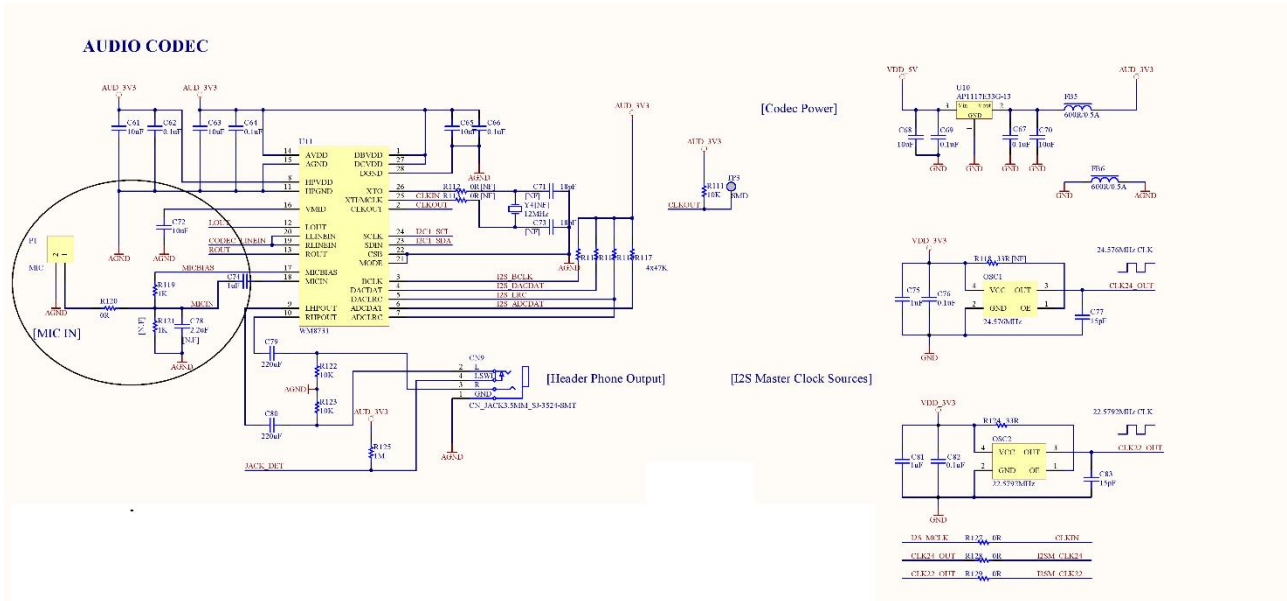

Figure 4-10 – Microphone Input

4.8.2 Audio Output

The Audio Codec also includes two audio inputs which are an I2S digital audio interface and stereo line. The stereo line can connect to external audio input sources (e.g. FT80X or FT81X family Audio PWM audio output).

There are two paths for stereo audio output provided by the audio codec device.

The first stereo audio output option is via headphone:

- **CN9**, a 3.5mm length, 4 contacts headphone jack.

The second option is via two speakers:

- **CN10**, right angle 2X 2 header for external speaker connection as Left and Right channel.
- **JP2**, 3-pin jumper controls speakers stereo audio output.

Pin No.	Name
1-2	Speakers On
2-3	Speakers Mute

Table 4-7 – JP2 Pinout

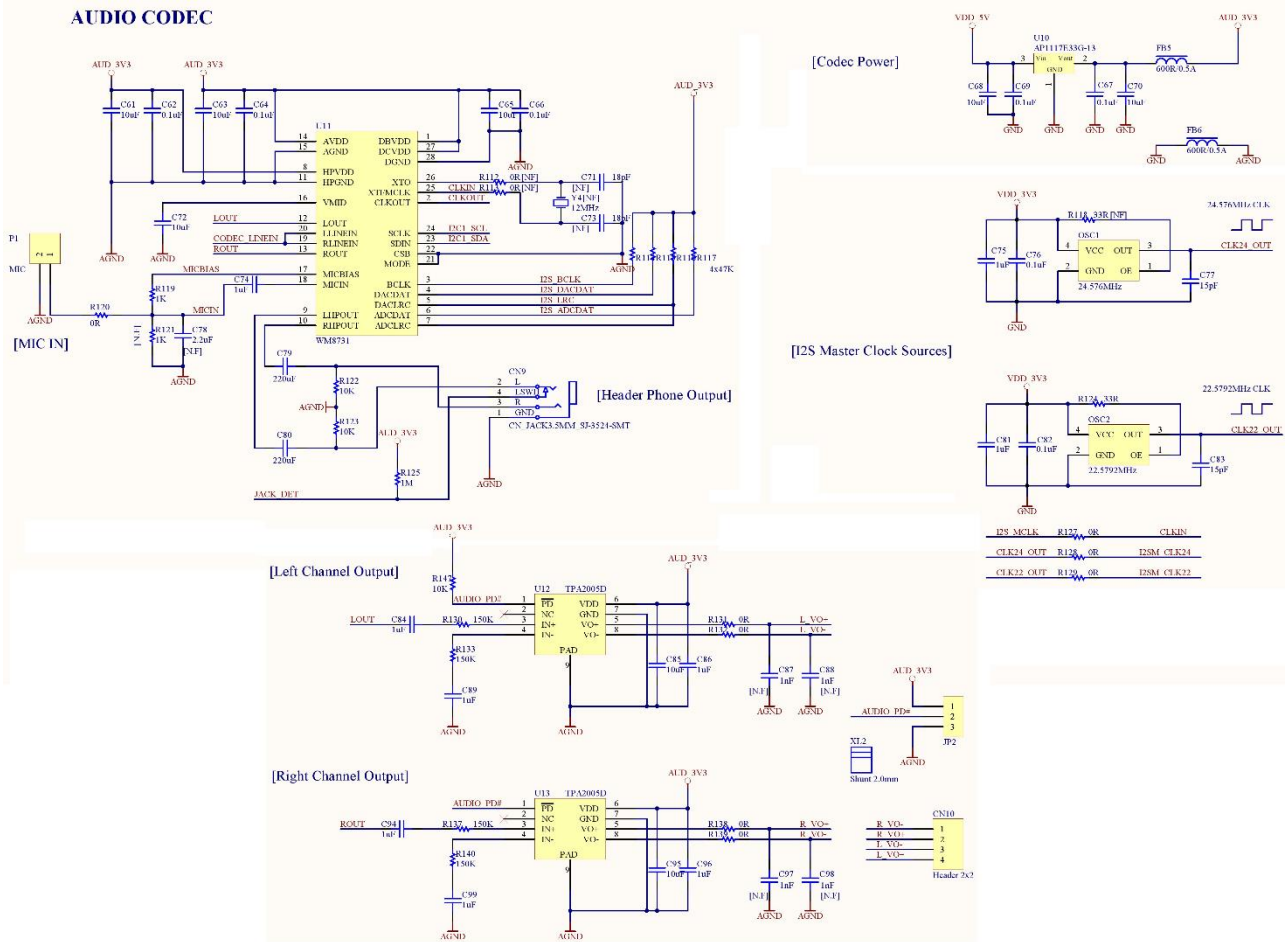

Figure 4-11 – Audio Output

4.9 Camera connector

The MM900EV2B/3B development boards have an Omni vision OV9655 camera module mounted either on the top (-EV2B) or the bottom (-EV3B) via a 24-pin 0.5mm pitching FFC/FPC, bottom contact connector on the board. See Table 4-8 camera connector pinout.

Pin No.	Name	Description
1	-	Reserved
2	GND	Ground
3	I2C0_SDA	I2C serial bus, data line
4	CAM_2V5	2.5V power supply
5	I2C0_SCL	I2C serial bus, clock line
6	RESETn	Hardware reset, active low
7	CAM_VD	Camera vertical sync input
8	CAM_PWDN	Camera module power down signal, active high
9	CAM_HD	Camera horizontal reference input
10	CAM_1V8	1.8V power supply
11	CAM_3V3	3.3V power supply

Pin No.	Name	Description
12	CAM_D7	Camera data line, Bit 7
13	CAM_XCLK	Camera external clock output
14	CAM_D6	Camera data line, Bit 6
15	GND	Ground
16	CAM_D5	Camera data line, Bit 5
17	CAM_PCLK	Camera pixel clock input
18	CAM_D4	Camera data line, Bit 4
19	CAM_D0	Camera data line, Bit 0
20	CAM_D3	Camera data line, Bit 3
21	CAM_D1	Camera data line, Bit 1
22	CAM_D2	Camera data line, Bit 2
23	Y1	Reserved
24	Y2	Reserved

Table 4-8 – Camera Connector Pinout

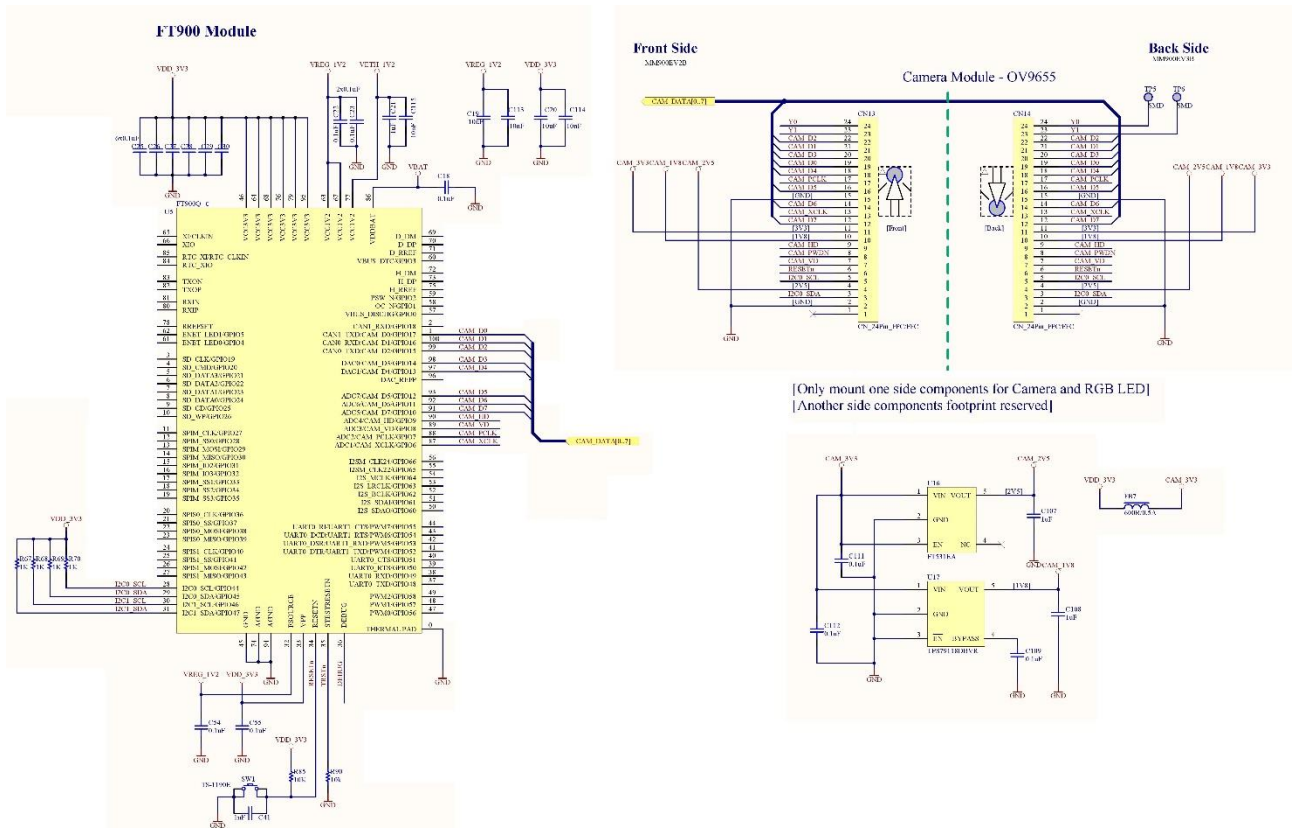

Composition of 24bit data:

G7	G6	G5	G4	G3	G2	G1	G0	R7	R6	R5	R4	R3	R2	R1	R0	B7	B6	B5	B4	B3	B2	B1	B0
----	----	----	----	----	----	----	----	----	----	----	----	----	----	----	----	----	----	----	----	----	----	----	----

Note: Follow the order of GRB to sent data and the high bit sent at first.

Table 4-9 – RGB LED 24-bit data order

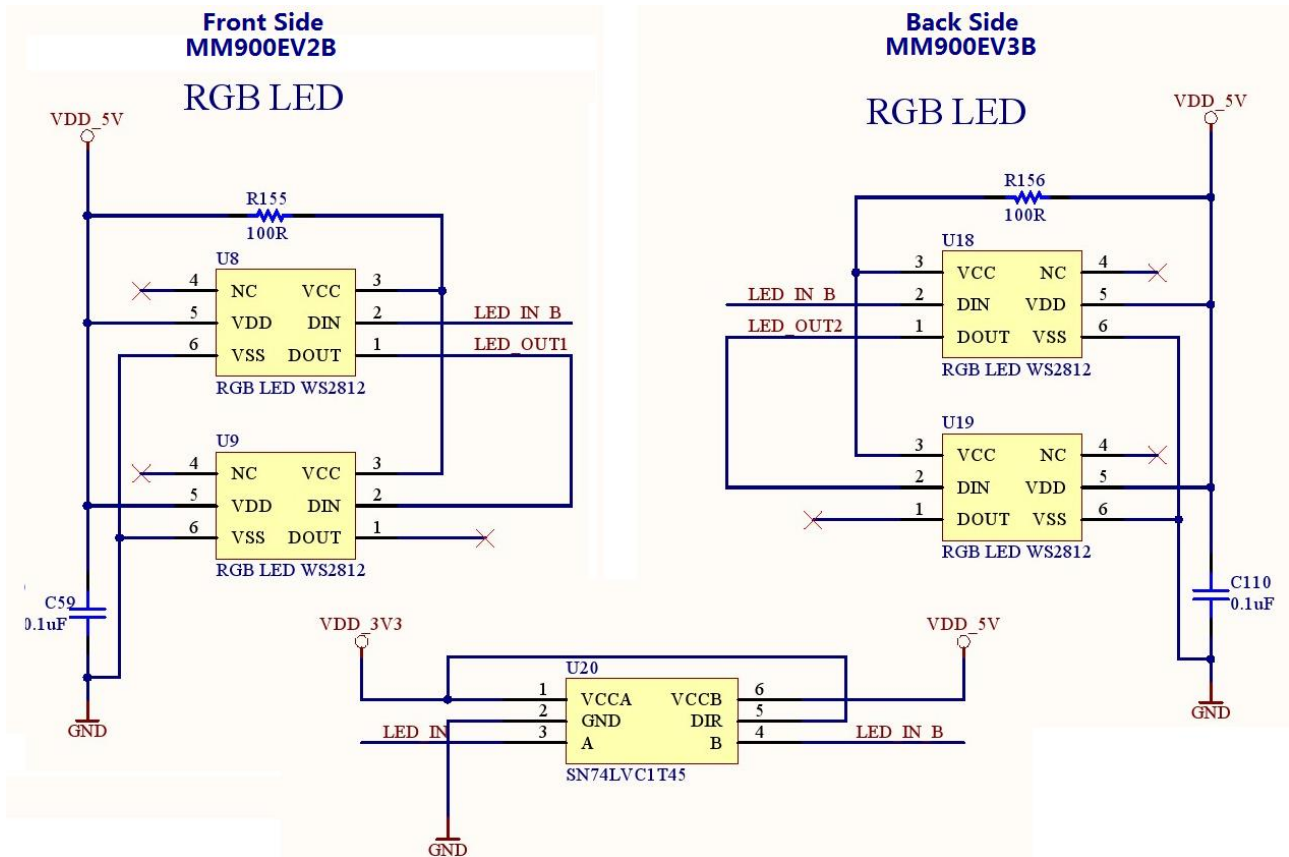

Figure 4-13 – RGB LEDs

4.11 RTC

The MM900EVxB development modules provide a 32.768 KHz quartz crystal and load capacitors for the FT900 internal Real Time Clock (RTC). There is a 1.5V non-rechargeable coin cell battery and socket on board.

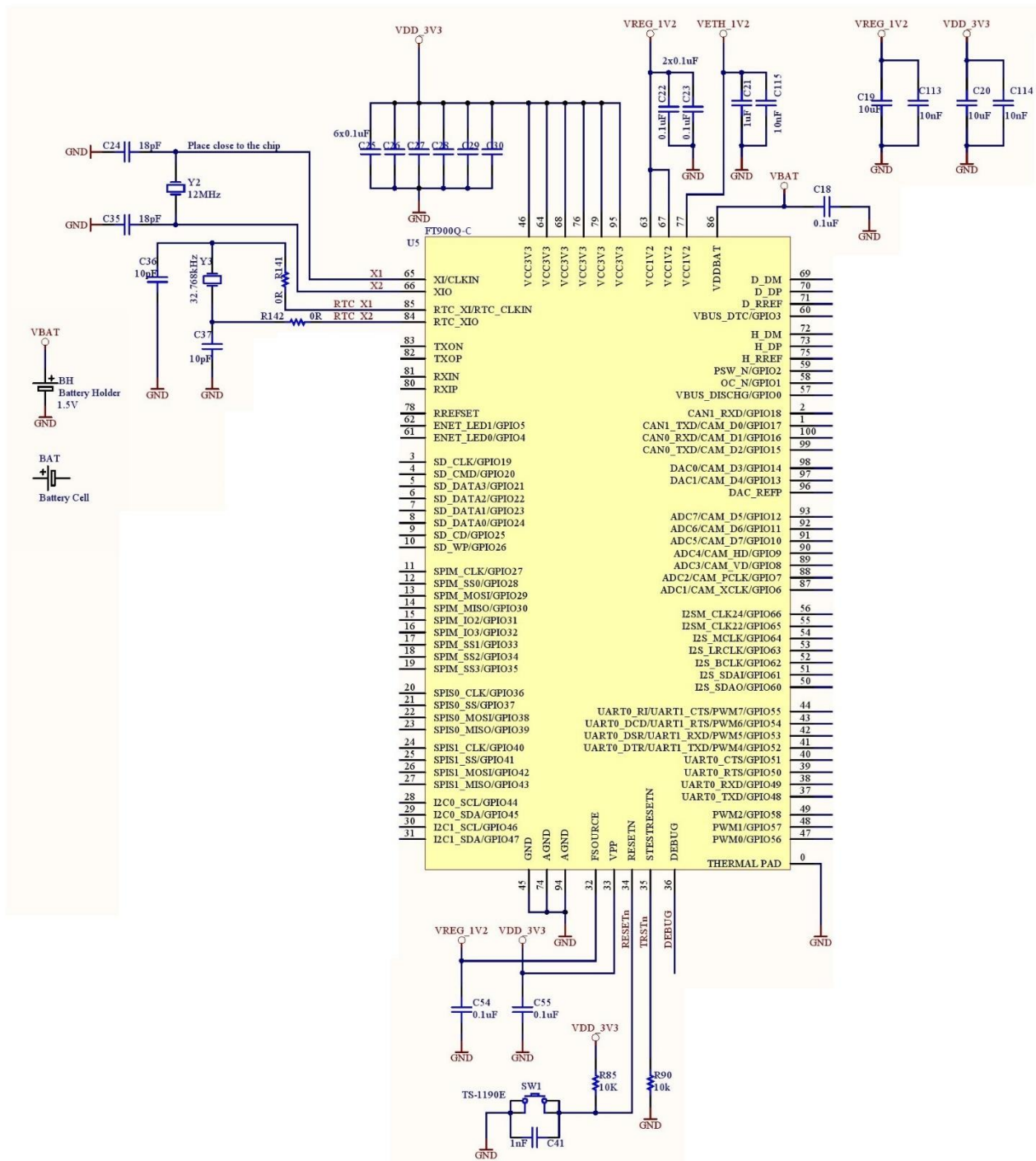

Figure 4-14 – RTC

4.12 External I/O Bus

There are 32 multiple function GPIOs provided on **CN3** 2x20 pins, 0.5mm pitch female header. External feature boards may connect via UART, PWM, ADC, DAC, SPI, I²C and Camera interfaces on this IO connector.

Table 4-10 lists all features assigned for each GPIO pin.

Pin No.	Function 1	Function 2	Function 3	Function 4
1,2,15,24	GND	-	-	-
3	GPIO54	UART0_DCD	UART1_RTS	PWM6
4	GPIO48	UART0_TXD	-	-
5	NC	-	-	-
6	GPIO49	UART0_RXD	-	-
7	GPIO53	UART0_DSR	UART1_RXD	PWM5
8	GPIO50	UART0_RTS	-	-
9	GPIO52	UART0_DTR	UART1_TXD	PWM4
10	GPIO51	UART0_CTS	-	-
11	GPIO55	UART0_RI	UART1_CTS	PWM7
12	GPIO58	-	-	PWM2
13	GPIO56	-	-	PWM0
14	GPIO57	-	-	PWM1
16	5V	-	-	-
17	GPIO35	SPIM_SS3	-	-
18	GPIO27	SPIM_CLK	-	-
19	GPIO30	SPIM_MISO	-	-
20	GPIO29	SPIM_MOSI	-	-
21	GPIO32	SPIM_IO3	-	-
22	GPIO31	SPIM_IO2	-	-
23	3V3	-	-	-
25	GPIO46	I2C1_SCL	-	-
26	GPIO47	I2C_SDA	-	-
27	GPIO08	CAM_VD	ADC3	-
28	GPIO09	CAM_HD	ADC4	-
29	GPIO07	CAM_PCLK	ADC2	-
30	GPIO06	CAM_XCLK	ADC1	-
31	GPIO10	CAM_D7	ADC5	-
32	GPIO11	CAM_D6	ADC6	-
33	GPIO12	CAM_D5	ADC7	-
34	GPIO13	CAM_D4	DAC1	-
35	GPIO14	CAM_D3	DAC0	-
36	GPIO15	CAM_D2	CAN0_TXD	-
37	GPIO16	CAM_D1	CAN0_RXD	-
38	GPIO17	CAM_D0	CAN1_TXD	-
39	RESETn	-	-	-
40	GPIO18	-	CAN1_RXD	-

Table 4-10 – External I/O Bus

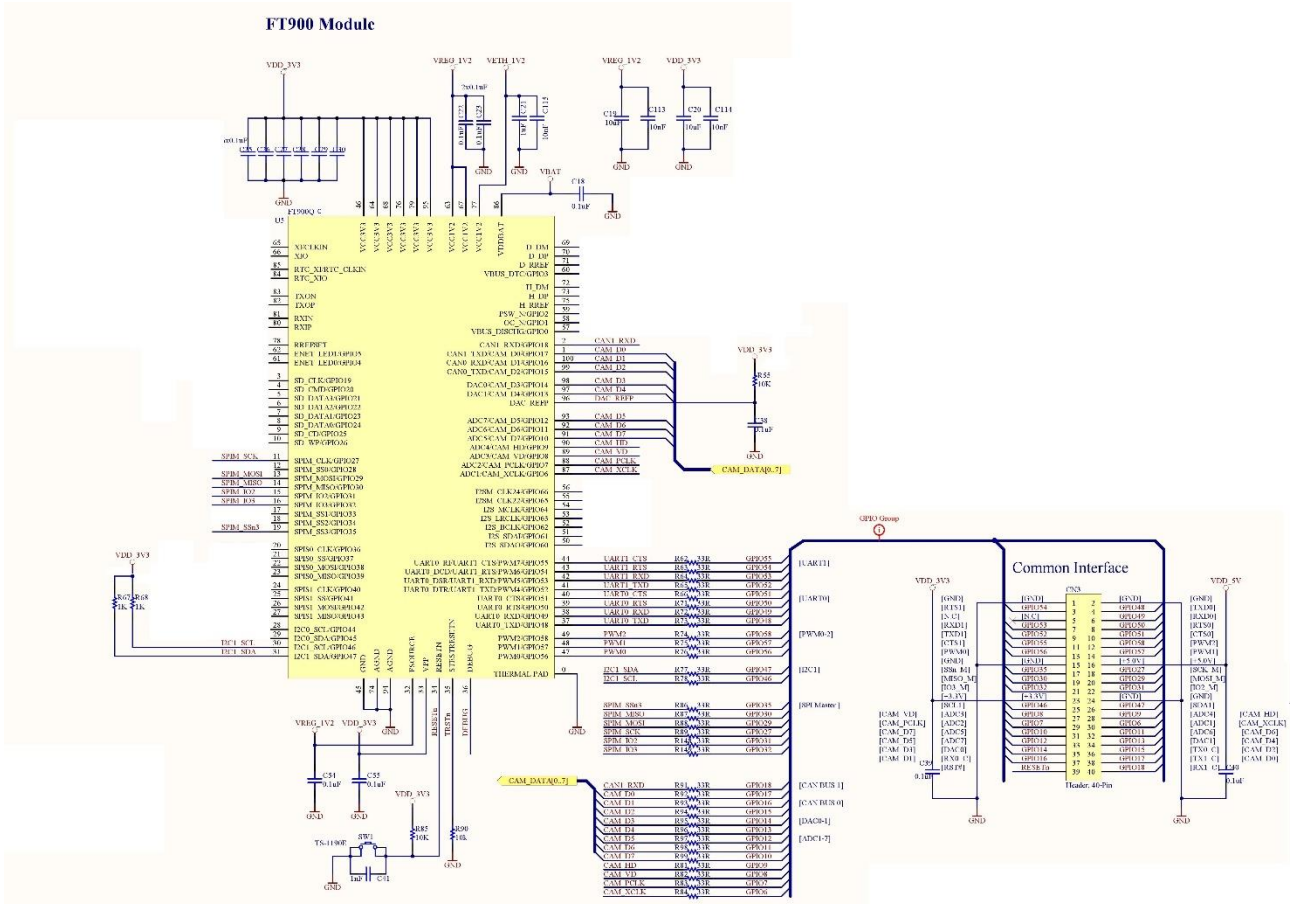

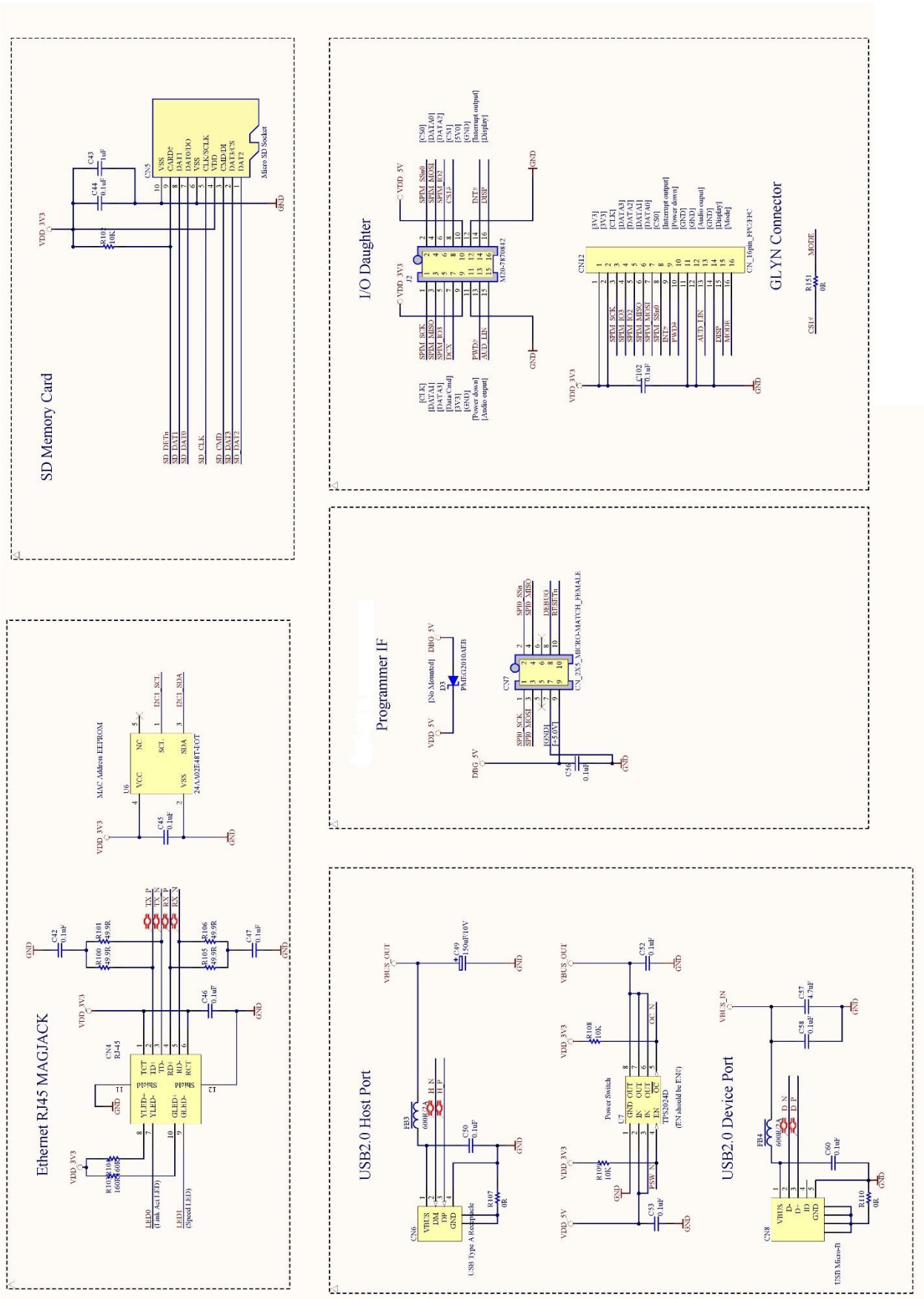
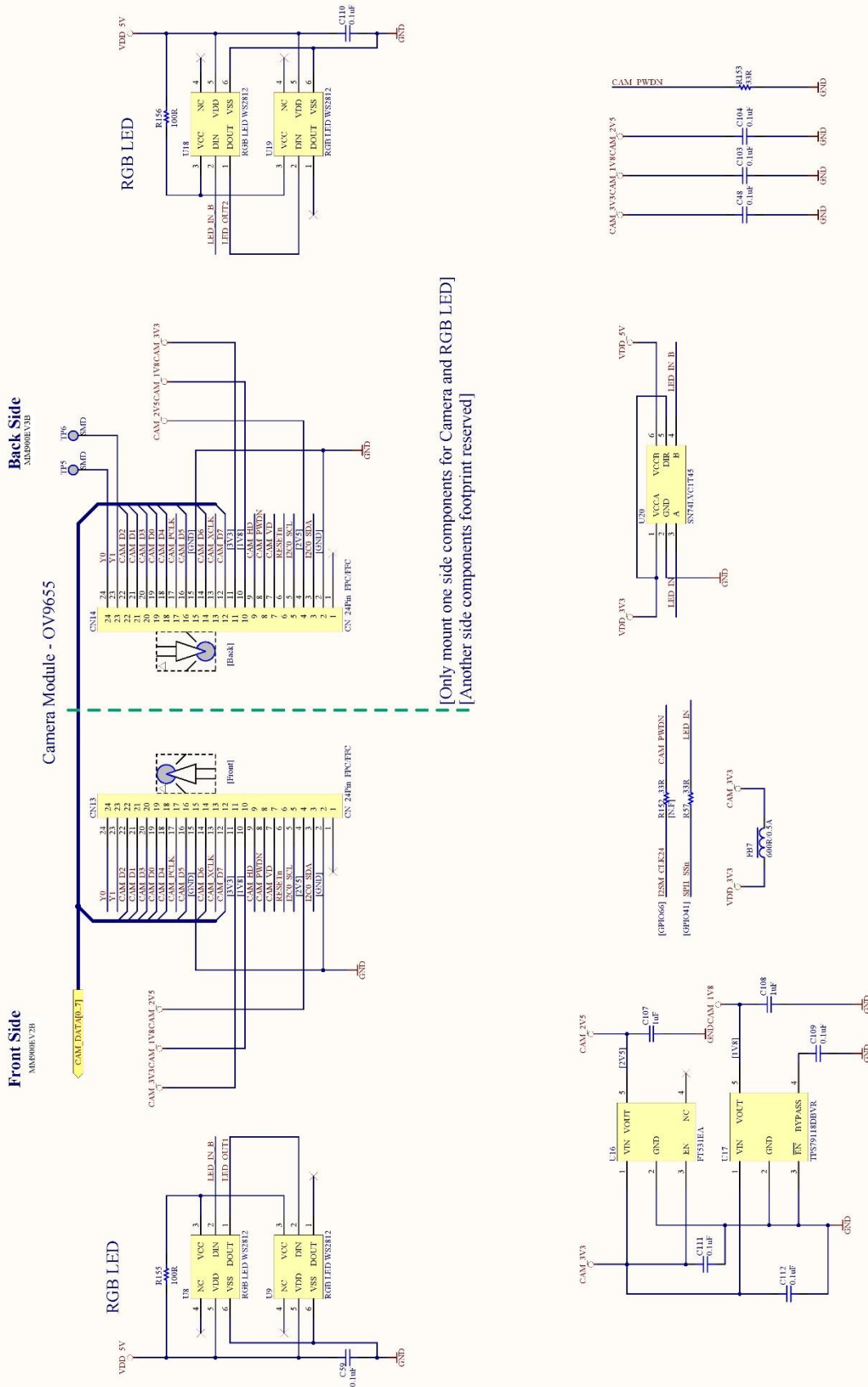

Figure 5-2 – Sheet 2- FT900 Interfaces and Connectors



[Only mount one side components for Camera and RGB LED]
[Another side components footprint reserved]

Figure 5-4 – Sheet 4-FT900 Camera Interface

6 Mechanical Dimensions

6.1 MM900EV1B PCB Dimensions

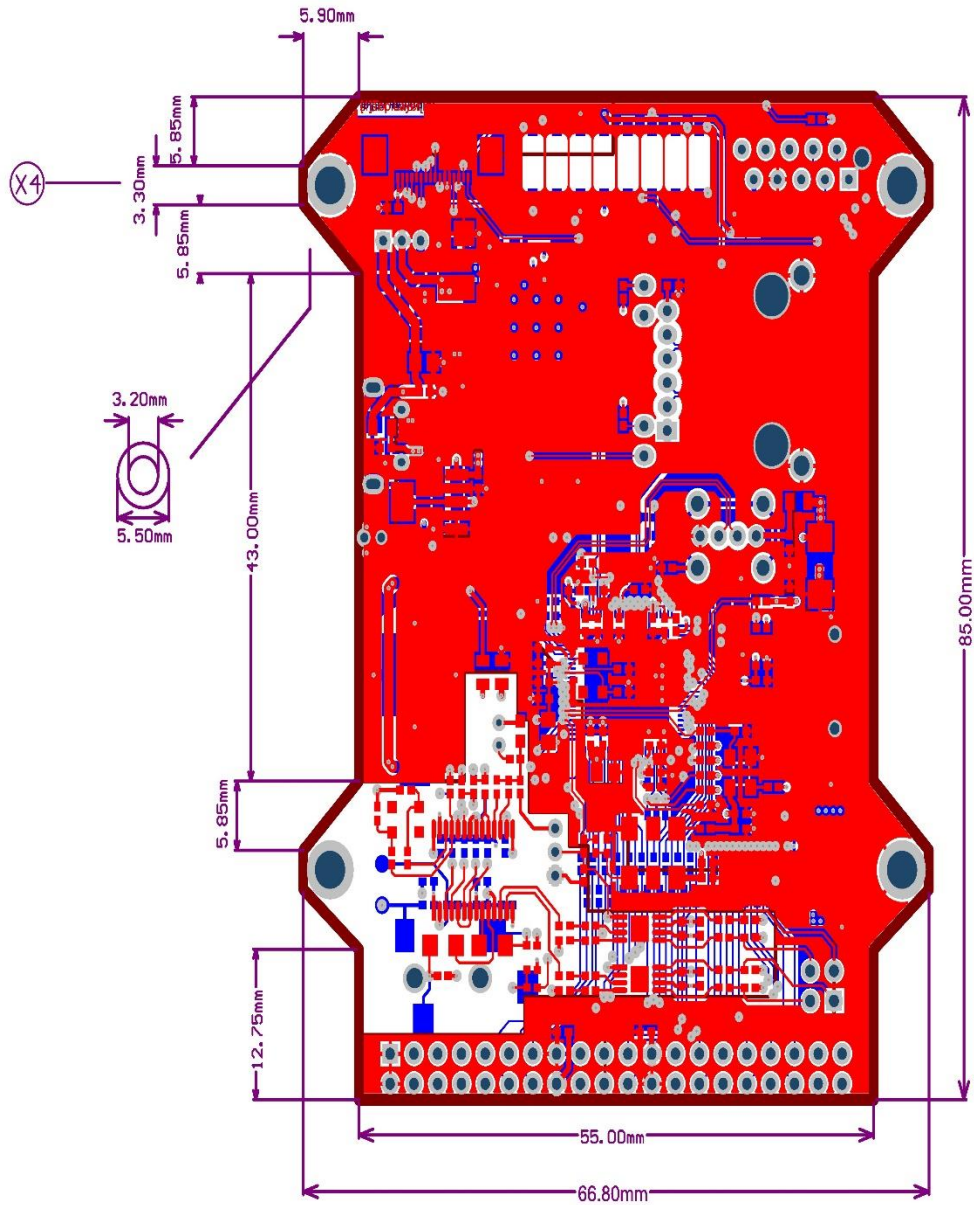

Figure 6-1 – MM900EV1B PCB Dimensions

6.2 MM900EV2B/3B PCB Dimensions

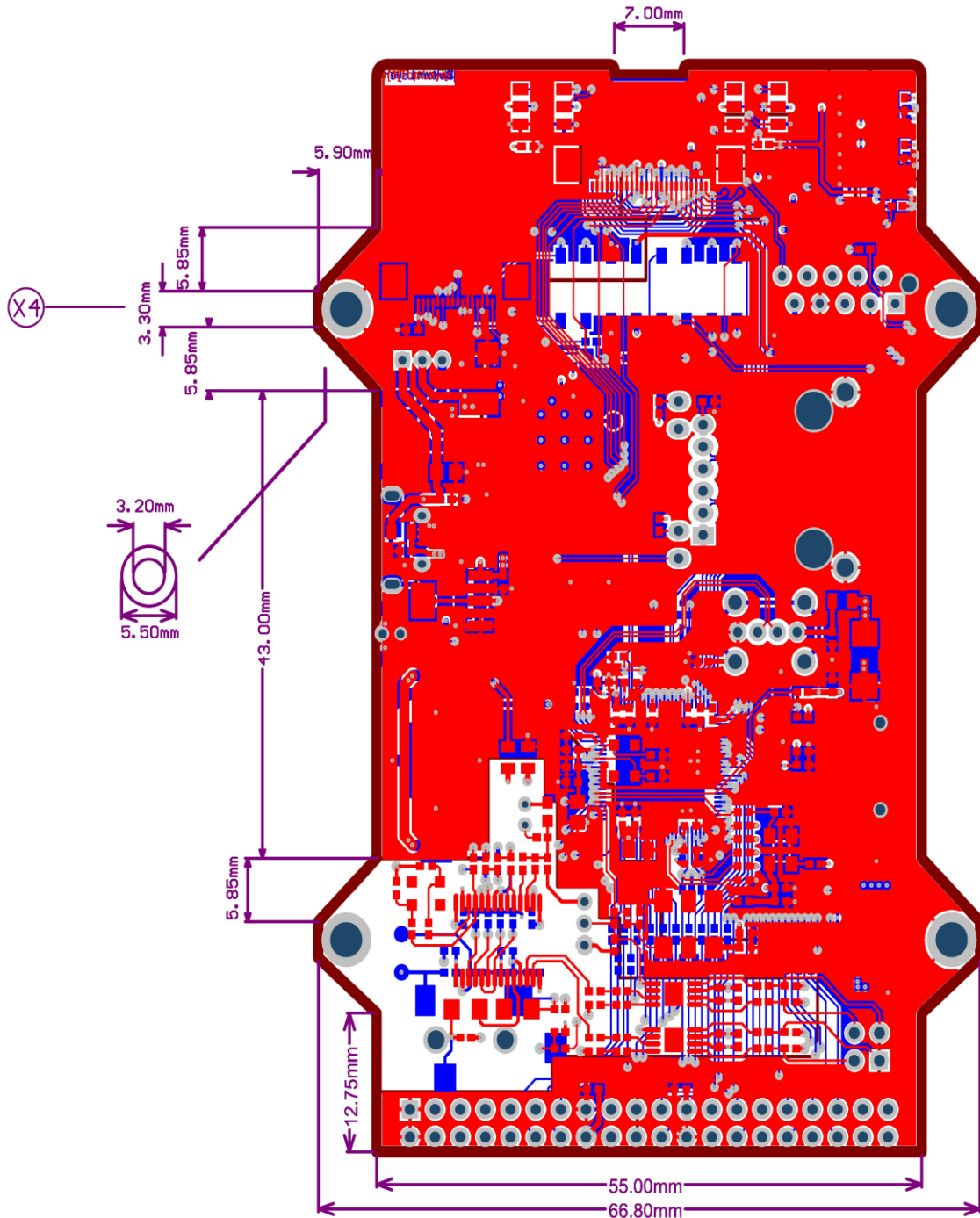

Figure 6-2 – MM900EV2B/3B PCB Dimensions

7 Contact Information

Head Quarters – Singapore

Bridgetek Pte Ltd
178 Paya Lebar Road, #07-03
Singapore 409030
Tel: +65 6547 4827
Fax: +65 6841 6071

E-mail (Sales) sales.apac@brtchip.com
E-mail (Support) support.apac@brtchip.com

Branch Office – Taipei, Taiwan

Bridgetek Pte Ltd, Taiwan Branch
2 Floor, No. 516, Sec. 1, Nei Hu Road, Nei Hu District
Taipei 114
Taiwan, R.O.C.
Tel: +886 (2) 8797 1330
Fax: +886 (2) 8751 9737

E-mail (Sales) sales.apac@brtchip.com
E-mail (Support) support.apac@brtchip.com

Branch Office - Glasgow, United Kingdom

Bridgetek Pte. Ltd.
Unit 1, 2 Seaward Place, Centurion Business Park
Glasgow G41 1HH
United Kingdom
Tel: +44 (0) 141 429 2777
Fax: +44 (0) 141 429 2758

E-mail (Sales) sales.emea@brtchip.com
E-mail (Support) support.emea@brtchip.com

Branch Office – Vietnam

Bridgetek VietNam Company Limited
Lutaco Tower Building, 5th Floor, 173A Nguyen Van
Troï,
Ward 11, Phu Nhuan District,
Ho Chi Minh City, Vietnam
Tel : 08 38453222
Fax : 08 38455222

E-mail (Sales) sales.apac@brtchip.com
E-mail (Support) support.apac@brtchip.com

Web Site

<http://brtchip.com/>

Distributor and Sales Representatives

Please visit the Sales Network page of the [Bridgetek Web site](#) for the contact details of our distributor(s) and sales representative(s) in your country.

System and equipment manufacturers and designers are responsible to ensure that their systems, and any Bridgetek Pte Ltd (BRT Chip) devices incorporated in their systems, meet all applicable safety, regulatory and system-level performance requirements. All application-related information in this document (including application descriptions, suggested Bridgetek devices and other materials) is provided for reference only. While Bridgetek has taken care to assure it is accurate, this information is subject to customer confirmation, and Bridgetek disclaims all liability for system designs and for any applications assistance provided by Bridgetek. Use of Bridgetek devices in life support and/or safety applications is entirely at the user's risk, and the user agrees to defend, indemnify and hold harmless Bridgetek from any and all damages, claims, suits or expense resulting from such use. This document is subject to change without notice. No freedom to use patents or other intellectual property rights is implied by the publication of this document. Neither the whole nor any part of the information contained in, or the product described in this document, may be adapted or reproduced in any material or electronic form without the prior written consent of the copyright holder. Bridgetek Pte Ltd, 178 Paya Lebar Road, #07-03, Singapore 409030. Singapore Registered Company Number: 201542387H.

Appendix A - References

Document References

FT90X webpage: <http://brtchip.com/ft900/>

FT90X datasheet: [FT900/FT901/FT902/FT903 Datasheet](#)

FT900 tool chain installation guide document: [AN_325 FT900 Tool Chain Installation Guide](#)

FT90X system registers: [AN_324 FT900 User Manual](#)

FT90X Peripheral Driver Library: [AN_365 FT900 API Programmers Manual](#)

FT90X Example Applications: [AN_360 FT90X Example Applications](#)

[FT90X Software Examples](#) and [FT9XX Software Examples](#) tier 2 examples.

UMFTPD2A program module datasheet: [DS_UMFTPD2A](#)

[EVE 2 Modules](#) compatible with MM900EVxB (ME812A-WH50R, ME813A-WH50C, ME810A-HV35R)

[BRT AN 019 Migration Guide](#) Moving From FF90x Revision B to Revision C

Acronyms and Abbreviations

Terms	Description
ADC	Analog to Digital Converter
DAC	Digital to Analog Converter
EVE	Embedded Video Engine
FFC	Flexible Flat Cable
FPC	Flexible Printed Circuit
I/O	Input / Output
I2C	Inter Integrated Circuit
I2S	Integrated Interchip Sound
IEEE	The Institute of Electrical and Electronics Engineers
LCD	Liquid Crystal Display
LDO	Low Drop Out regulator
LED	Light-emitting diode
PCB	Printed Circuit Board
PWM	Pulse Width Modulation
QFN	Quad Flat No Leads
RGB	Red Green Blue (color model)

RTC	Real Time Clock
SPI	Serial Peripheral Interface
UHS	Ultra High Speed
USB	Universal Serial Bus
UART	Universal Asynchronous Receiver/Transmitter
GDB	General Debugging Breakpoint

Appendix B - List of Figures and Tables

List of Figures

Figure 4-1 – MM900EV1B Board Layout	6
Figure 4-2 – MM900EV2B/3B Board Layout	7
Figure 4-3 – Power supply	8
Figure 4-4 – FT900 Microcontroller.....	8
Figure 4-5 – Micro SD Connector	9
Figure 4-6 – USB Connectors	10
Figure 4-7 – Ethernet connector	12
Figure 4-8 – Program Interface	13
Figure 4-9 – SPI Master Interface	14
Figure 4-10 – Microphone Input.....	17
Figure 4-11 – Audio Output.....	18
Figure 4-12 – Camera connector.....	19
Figure 4-13 – RGB LEDs	20
Figure 4-14 – RTC.....	21
Figure 4-15 – External I/O Bus	23
Figure 5-1 – Sheet 1-FT900 MCU	24
Figure 5-2 – Sheet 2- FT900 Interfaces and Connectors	25
Figure 5-3 – Sheet 3-FT900 Audio Codec	26
Figure 5-4 – Sheet 4-FT900 Camera Interface.....	27
Figure 6-1 – MM900EV1B PCB Dimensions	28
Figure 6-2 – MM900EV2B/3B PCB Dimensions	29

List of Tables

Table 2-1 – Ordering information	2
Table 4-1 – JP3 Pinout.....	7
Table 4-2 – Ethernet LEDs	11
Table 4-3 – CN7 Pinout.....	13
Table 4-4 – J2 Pinout	15
Table 4-5 – CN12 Pinout.....	16
Table 4-6 – P1 Microphone Specifications.....	16
Table 4-7 – JP2 Pinout.....	17
Table 4-8 – Camera Connector Pinout	19
Table 4-9 – RGB LED 24-bit data order.....	20
Table 4-10 – External I/O Bus	22

Appendix C – Revision History

Document Title : MM900EVxB Datasheet
Document Reference No. : BRT_000221
Clearance No. : BRT#125
Product Page : <http://brtchip.com/ft900/>
Document Feedback : [Send Feedback](#)

Revision	Changes	Date
1.0	Initial Release	2018-01-23



**Стандарт
Электрон
Связь**

Мы молодая и активно развивающаяся компания в области поставок электронных компонентов. Мы поставляем электронные компоненты отечественного и импортного производства напрямую от производителей и с крупнейших складов мира.

Благодаря сотрудничеству с мировыми поставщиками мы осуществляем комплексные и плановые поставки широчайшего спектра электронных компонентов.

Собственная эффективная логистика и склад в обеспечивает надежную поставку продукции в точно указанные сроки по всей России.

Мы осуществляем техническую поддержку нашим клиентам и предпродажную проверку качества продукции. На все поставляемые продукты мы предоставляем гарантию .

Осуществляем поставки продукции под контролем ВП МО РФ на предприятия военно-промышленного комплекса России , а также работаем в рамках 275 ФЗ с открытием отдельных счетов в уполномоченном банке. Система менеджмента качества компании соответствует требованиям ГОСТ ISO 9001.

Минимальные сроки поставки, гибкие цены, неограниченный ассортимент и индивидуальный подход к клиентам являются основой для выстраивания долгосрочного и эффективного сотрудничества с предприятиями радиоэлектронной промышленности, предприятиями ВПК и научно-исследовательскими институтами России.

С нами вы становитесь еще успешнее!

Наши контакты:

Телефон: +7 812 627 14 35

Электронная почта: sales@st-electron.ru

Адрес: 198099, Санкт-Петербург,
Промышленная ул, дом № 19, литера Н,
помещение 100-Н Офис 331