

MAX16122–MAX16125

Dual Pushbutton Controllers in Tiny 6-Bump WLP Package

General Description

The MAX16122–MAX16125 pushbutton controllers with single-supply monitors monitor one or two pushbuttons and generate a hard reset signal if the buttons are pushed and held for a setup delay. These devices make it easy to “hide” the hard reset function in an existing pushbutton, such as a soft power switch. The devices operate from 1.6V to 5.5V and consume a quiescent current of only 5µA at 3V.

The MAX16122–MAX16125 have pin-programmable or resistor-adjustable setup delay. Connect the SEL pin to GND, V_{CC}, or leave it unconnected to select the different setup delays (depending on part suffix, see [Table 1a](#)) or connect an external resistor from SEL to GND to set the setup delays (E suffix only, see [Table 1b](#)).

The MAX16124/MAX16125 have one manual reset input ($\overline{\text{MR}}$), a reset output ($\overline{\text{RESET}}$), and a soft reset output ($\overline{\text{SRESET}}$) which mirrors the state of the input. The MAX16122/MAX16123 have two identical manual reset inputs ($\overline{\text{MR1}}$ and $\overline{\text{MR2}}$) and one reset output ($\overline{\text{RESET}}$). A deglitch block is connected to each input to add a delay to the falling edge with a fixed deglitch period of 20ms (t_{DB}).

The MAX16122–MAX16125 feature a comparator that monitors the input supply voltage. A variety of factory-trimmed threshold options accommodate different supply voltages and tolerances, eliminating external components. The factory-set reset thresholds range from 1.58V to 4.63V to monitor 5V, 3.3V, 2.5V, and 1.8V supplies.

The MAX16122–MAX16125 are offered in a tiny 0.86mm x 1.27mm, 6-bump WLP package and are specified over the automotive temperature range (-40°C to +125°C).

Benefits and Features

- ◆ **Low Supply Current:** < 5µA (typ) at 3V Over Temperature
- ◆ **Precision Factory-Set V_{CC} Monitoring Threshold for 1.8V, 2.5V, 3.3V, and 5V Supplies**
- ◆ **Fixed/Pin-Programmable or Resistor-Adjustable Pushbutton Setup Delay**
- ◆ **Up to 2 Reset Outputs and 2 Debounced Pushbutton Inputs**
- ◆ **Guaranteed $\overline{\text{RESET}}$ Valid for V_{CC} Down to 0.95V**
- ◆ **Active-Low $\overline{\text{RESET}}$ Output (Push-Pull or Open-Drain)**
- ◆ **Immune to Short Power-Supply Transients**
- ◆ **0.86mm x 1.27mm 6-Bump WLP Package**
- ◆ **-40°C to +125°C Operating Temperature Range**

Applications

Smartphones
Tablet PCs
eBook Readers
Portable/Battery-Powered Equipment
Glucose Monitors/Patient Monitors
Portable Instrumentation

Ordering Information appears at end of data sheet.

For related parts and recommended products to use with this part, refer to www.maximintegrated.com/MAX16122.related.

Typical Operating Circuits

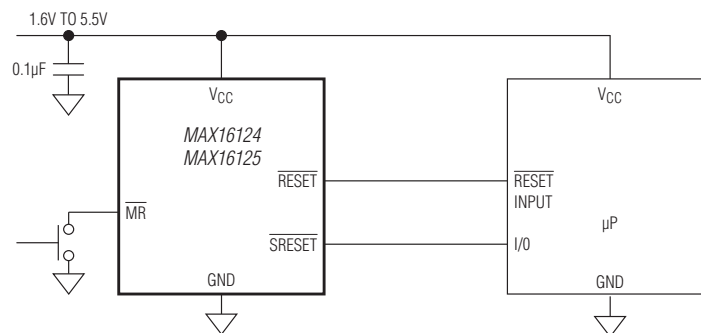

Typical Operating Circuits (continued) at end of data sheet.

MAX16122–MAX16125

Dual Pushbutton Controllers in Tiny 6-Bump WLP Package

ABSOLUTE MAXIMUM RATINGS

(All pins referenced to GND)

V_{CC}	-0.3V to +6V	Input/Output Current (all pins)	20mA
\overline{RESET} , \overline{SRESET} to GND		Continuous Power Dissipation ($T_A = +70^\circ\text{C}$) (Multilayer Board)	
Open-Drain.....	-0.3V to +6V	WLP (derate 10.5mW/ $^\circ\text{C}$ above $+70^\circ\text{C}$).....	840mW
Push-Pull.....	-0.3V to ($V_{CC} + 0.3\text{V}$)	Operating Temperature Range	-40°C to $+125^\circ\text{C}$
MR, MR1, MR2	-0.3V to +6V	Junction Temperature	$+150^\circ\text{C}$
SEL	-0.3V to +6V	Storage Temperature Range.....	-65°C to $+150^\circ\text{C}$
		Soldering Temperature (reflow)	$+260^\circ\text{C}$

Stresses beyond those listed under "Absolute Maximum Ratings" may cause permanent damage to the device. These are stress ratings only, and functional operation of the device at these or any other conditions beyond those indicated in the operational sections of the specifications is not implied. Exposure to absolute maximum rating conditions for extended periods may affect device reliability.

PACKAGE THERMAL CHARACTERISTICS (Note 1)

WLP

Junction-to-Ambient Thermal Resistance (θ_{JA}) $95^\circ\text{C}/\text{W}$

Note 1: Package thermal resistances were obtained using the method described in JEDEC specification JESD51-7, using a four-layer board. For detailed information on package thermal considerations, refer to www.maximintegrated.com/thermal-tutorial.

ELECTRICAL CHARACTERISTICS

($V_{CC} = 1.6\text{V}$ to 5.5V , $T_A = -40^\circ\text{C}$ to $+125^\circ\text{C}$, unless otherwise noted. Typical values are at $T_A = +25^\circ\text{C}$.) (Note 2)

PARAMETER	SYMBOL	CONDITIONS	MIN	TYP	MAX	UNITS
Operating Voltage Range	V_{CC}	\overline{RESET} state guaranteed for $V_{CC} \geq 0.95\text{V}$	1.6		5.5	V
V_{CC} Undervoltage Lockout	V_{CCUVLO}			1.25	1.55	V
V_{CC} Supply Current	I_{CC}	$V_{CC} = 5\text{V}$, steady-state condition; \overline{MR} , $\overline{MR1}$, $\overline{MR2}$, \overline{RESET} , and \overline{SRESET} not asserted		8	10	μA
Supply Current with Oscillator Running	I_{CC2}	$V_{CC} = 3\text{V}$		5	10	μA
V_{CC} Reset Threshold	V_{TH}	V_{CC} falling	-2.5%	V_{TH}	+2.5%	V
V_{CC} Reset Threshold Hysteresis	V_{HYST}			2		%
Reset Threshold Tempco				30		ppm/ $^\circ\text{C}$
V_{CC} to \overline{RESET} Output Delay	t_D	V_{CC} falling at $10\text{mV}/\mu\text{s}$ from ($V_{TH} + 100\text{mV}$) to ($V_{TH} - 100\text{mV}$)		10		μs
Reset Timeout Period	t_{RP}	See Table 2	-10	t_{RP}	+10	%
Manual Reset Setup Delay	t_{SU}	Internal timing (see Tables 1a, 1b, 1c)	-10	t_{SU}	+10	%
Debounce Period	t_{DB}		18	20	22	ms

MAX16122–MAX16125

Dual Pushbutton Controllers in Tiny 6-Bump WLP Package

ELECTRICAL CHARACTERISTICS (continued)

($V_{CC} = 1.6V$ to $5.5V$, $T_A = -40^\circ C$ to $+125^\circ C$, unless otherwise noted. Typical values are at $T_A = +25^\circ C$.) (Note 2)

PARAMETER	SYMBOL	CONDITIONS	MIN	TYP	MAX	UNITS
OUTPUTS (\overline{RESET}, \overline{SRESET})						
\overline{RESET} , \overline{SRESET} Output Low	V_{OL}	$V_{CC} = V_{TH(MIN)}$, $V_{TH} > 4.25V$, $I_{SINK} = 10mA$			0.4	V
		$V_{CC} = V_{TH(MIN)}$, $V_{TH} > 2.5V$, $I_{SINK} = 3.2mA$			0.4	V
		$V_{CC} = V_{TH(MIN)}$, $V_{TH} > 1.67V$, $I_{SINK} = 1mA$			0.4	V
		$V_{CC} = V_{TH(MIN)}$, $V_{TH} > 1V$, $I_{SINK} = 100\mu A$			0.4	V
		$V_{CC} > 0.95V$, V_{CC} falling, $I_{SINK} = 15\mu A$			0.4	V
\overline{RESET} , \overline{SRESET} Output High (Push-Pull Outputs)	V_{OH}	$V_{CC} > 0.95V$, $I_{SOURCE} = 15\mu A$	$0.8 \times$ V_{CC}			V
		$V_{CC} > 1.2V$, $I_{SOURCE} = 100\mu A$	$0.8 \times$ V_{CC}			V
		$V_{CC} > 1.67V$, $I_{SOURCE} = 150\mu A$	$0.8 \times$ V_{CC}			V
		$V_{CC} > 2.7V$, $I_{SOURCE} = 500\mu A$	$0.8 \times$ V_{CC}			V
		$V_{CC} > 4.5V$, $I_{SOURCE} = 800\mu A$	$0.8 \times$ V_{CC}			V
\overline{RESET} , \overline{SRESET} Output Leakage Current (Open-Drain Outputs)					1	μA
MANUAL RESET INPUTS (\overline{MR}, $\overline{MR1}$, $\overline{MR2}$)						
$\overline{MR1}$, $\overline{MR2}$, \overline{MR} Input Voltage Low	V_{IL}				$0.3 \times V_{CC}$	V
$\overline{MR1}$, $\overline{MR2}$, \overline{MR} Input Voltage High	V_{IH}				$0.7 \times V_{CC}$	V
Manual Reset Minimum Pulse Width				1		μs
Manual Reset Glitch Rejection				100		ns
Manual Reset to Soft Reset Delay	t_{MRD}			200		ns
$\overline{MR1}$, $\overline{MR2}$, \overline{MR} Internal Pullup Resistance			25	50	80	$k\Omega$
SELECT (\overline{SEL}) LOGIC INPUT						
\overline{SEL} Input Low Voltage					$0.15 \times$ V_{CC}	V
\overline{SEL} Input High Voltage			$0.85 \times$ V_{CC}			V
\overline{SEL} Input Leakage			-8		+8	μA

Note 2: All parameters are production tested at $T_A = +25^\circ C$. Limits over the operating temperature range are guaranteed by design.

MAX16122–MAX16125

Dual Pushbutton Controllers in Tiny 6-Bump WLP Package

Typical Operating Characteristics

($V_{CC} = 5V$, MAX16125WTDB29+, $T_A = +25^\circ C$, unless otherwise noted.)

SUPPLY CURRENT vs. SUPPLY VOLTAGE

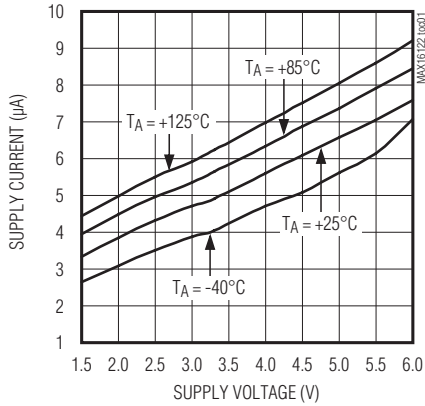

SUPPLY CURRENT vs. TEMPERATURE

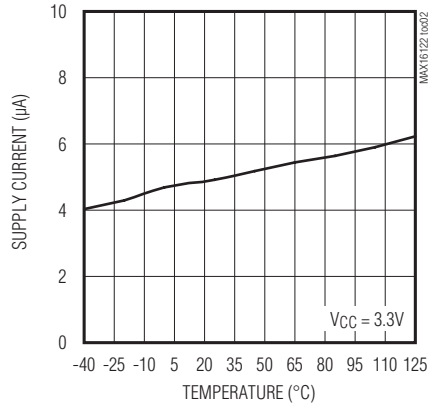

RESET TIMEOUT PERIOD vs. TEMPERATURE

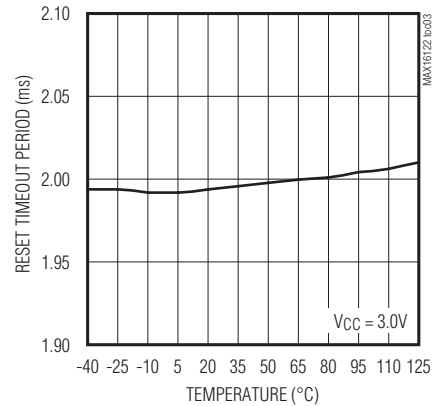

MAXIMUM V_{CC} TRANSIENT DURATION vs. RESET THRESHOLD OVERDRIVE

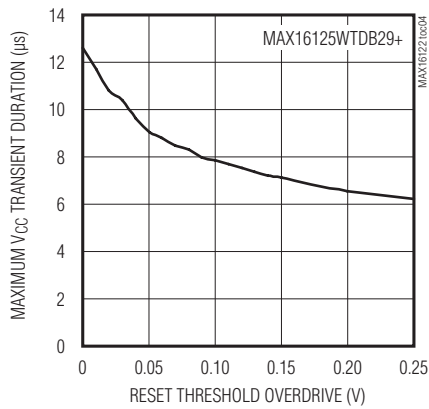

V_{CC} RESET THRESHOLD vs. TEMPERATURE

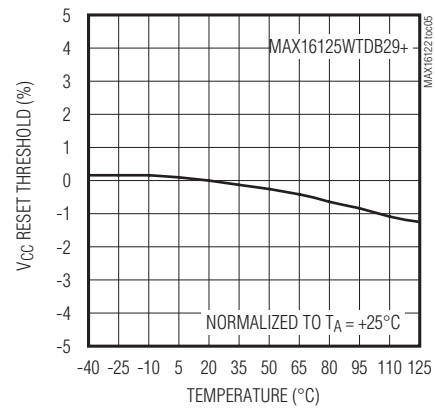

MAX16122–MAX16125

Dual Pushbutton Controllers in Tiny 6-Bump WLP Package

Typical Operating Characteristics (continued)

($V_{CC} = 5V$, MAX16125WTDB29+, $T_A = +25^\circ C$, unless otherwise noted.)

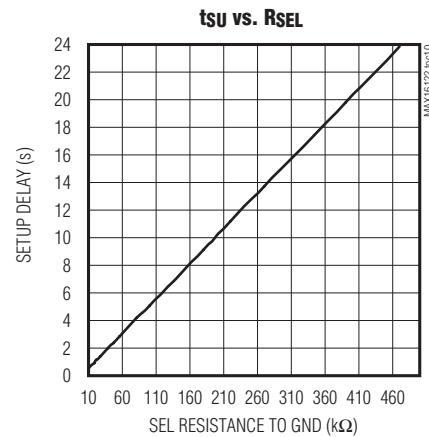
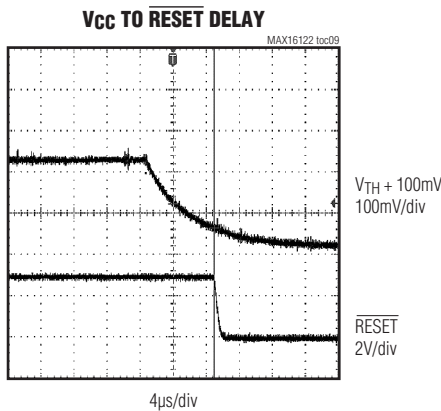
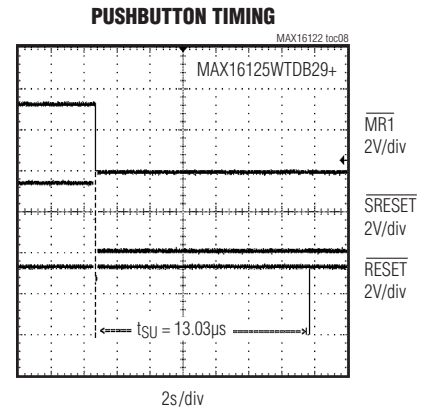
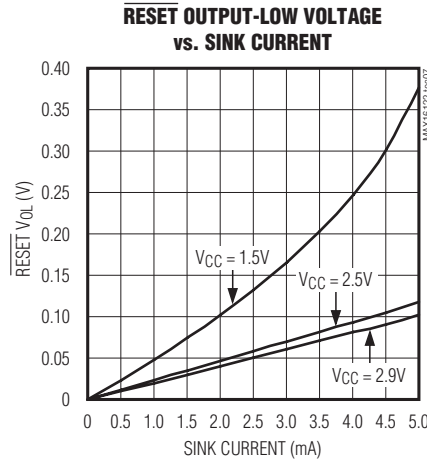
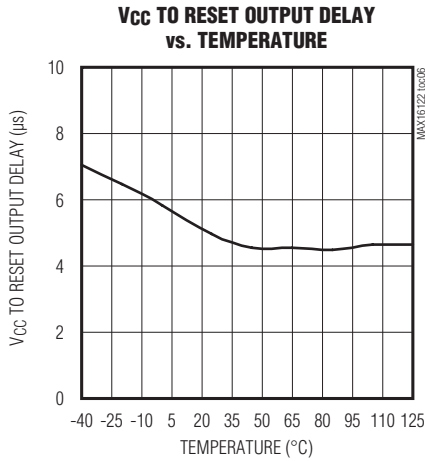

MAX16122–MAX16125

Dual Pushbutton Controllers in Tiny 6-Bump WLP Package

Bump Configurations

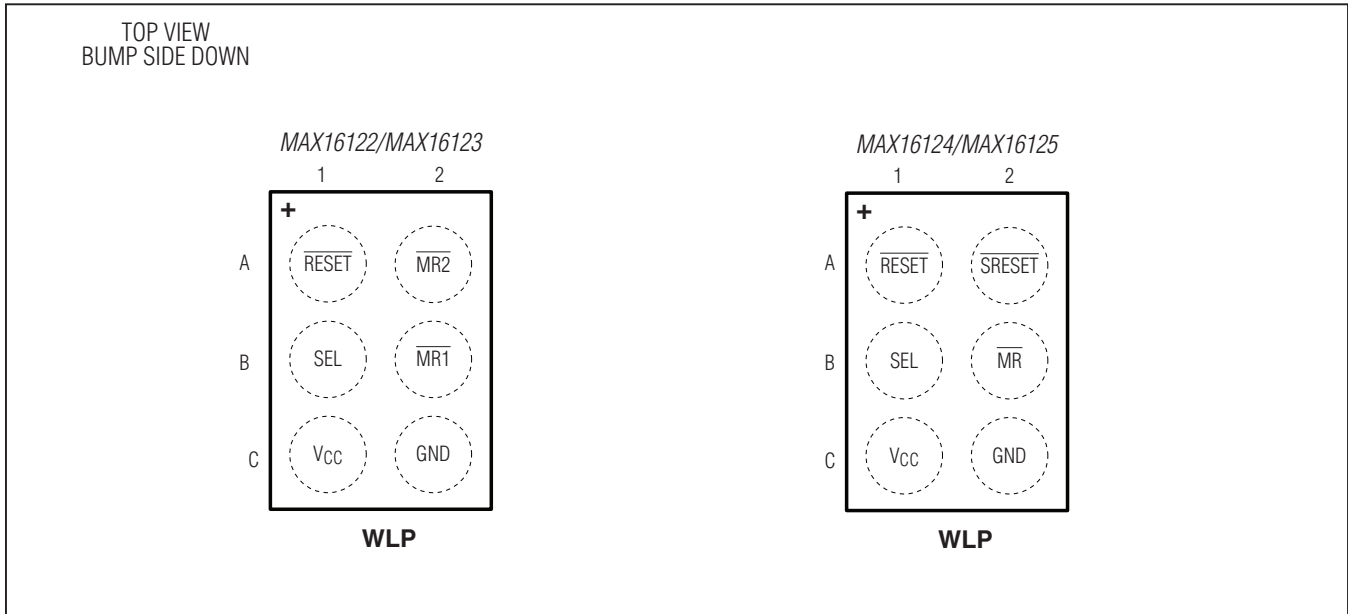

Bump Description

BUMP		NAME	FUNCTION
MAX16122/ MAX16123	MAX16124/ MAX16125		
A1	A1	$\overline{\text{RESET}}$	Active-Low Reset Output. $\overline{\text{RESET}}$ is either an open-drain or a push-pull output (see the <i>Selector Guide</i>). $\overline{\text{RESET}}$ asserts low when V_{CC} drops below the selected threshold and remains low for the V_{CC} reset timeout period after V_{CC} rises above the reset threshold. The $\overline{\text{RESET}}$ one-shot asserts low for the reset timeout period when the manual reset input is asserted longer than the setup delay. The open-drain output requires an external pullup resistor.
—	A2	$\overline{\text{SRESET}}$	Soft Reset Output. $\overline{\text{SRESET}}$ is the debounced version of $\overline{\text{MR}}$.
B1	B1	SEL	Setup Delay Select Input. Connect SEL to V_{CC} , GND, or leave unconnected to select a desired setup delay (see Table 1a); or connect an external resistor between SEL and GND to select a desired setup delay (E suffix only, see Tables 1a and 1b).
—	B2	$\overline{\text{MR}}$	Manual Reset Input. Internal 50k Ω pullup to V_{CC} . Pull $\overline{\text{MR}}$ low for the setup delay (t_{SU}) to one-shot pulse $\overline{\text{RESET}}$ for the reset timeout period.

MAX16122–MAX16125

Dual Pushbutton Controllers in Tiny 6-Bump WLP Package

Bump Description (continued)

BUMP		NAME	FUNCTION
MAX16122/ MAX16123	MAX16124/ MAX16125		
C1	C1	V _{CC}	Power-Supply Input. V _{CC} provides power to the device and is also a monitored voltage. When V _{CC} drops below the selected threshold, $\overline{\text{RESET}}$ asserts low and remains low for the reset timeout period after V _{CC} rises above the threshold. Bypass V _{CC} to GND with a 0.1μF capacitor.
C2	C2	GND	Ground
B2	—	$\overline{\text{MR1}}$	Active-Low Manual Reset Input 1. Internal 50kΩ pullup to V _{CC} . Pull both $\overline{\text{MR1}}$ and $\overline{\text{MR2}}$ low for the setup delay (t _{SU}) to one-shot pulse $\overline{\text{RESET}}$ for the reset timeout period.
A2	—	$\overline{\text{MR2}}$	Active-Low Manual Reset Input 2. Internal 50kΩ pullup to V _{CC} . Pull the $\overline{\text{MR2}}$ and $\overline{\text{MR1}}$ low for the setup delay (t _{SU}) to one-shot pulse $\overline{\text{RESET}}$ for the reset timeout period.

Detailed Description

The MAX16122–MAX16125 low-current microprocessor reset circuits feature single or dual manual reset inputs with an extended setup period. The devices also feature an internal comparator to monitor 5V, 3.3V, 2.5V, and 1.8V supplies.

When the monitored supply voltage drops below the specified threshold, the active-low $\overline{\text{RESET}}$ output asserts low and remains low for the reset timeout period (t_{RP}). The $\overline{\text{RESET}}$ output is one-shot pulse asserted for the reset timeout period. Supply voltage reset threshold is selectable through part suffix, see [Table 3](#).

Connect SEL to GND, V_{CC}, or leave unconnected to select the different setup delays (depending on part suffix, see [Table 1a](#)), or connect to an external resistor to set the setup delays (E suffix only, see [Table 1b](#)).

The MAX16124/MAX16125 have one manual reset input ($\overline{\text{MR}}$), one reset output ($\overline{\text{RESET}}$), and one soft reset output ($\overline{\text{SRESET}}$). The MAX16122/MAX16123 have two identical manual reset inputs ($\overline{\text{MR1}}$ and $\overline{\text{MR2}}$) and one reset output ($\overline{\text{RESET}}$). A deglitch block is connected to each manual reset input to add a delay to the falling edge with a fixed deglitch period of 20ms (t_{DB}).

Resistor-Adjusted Setup Delay

For the MAX16122–MAX16125 with the E setup delay suffix (MAX1612_WTE_+T), a resistor connected from SEL to GND sets the setup delay. [Table 1b](#) shows common resistor values and the resulting setup delays. For resistor values not in the table, use the following formula to compute the setup delay:

$$t_{\text{SU}} = \frac{R}{20}$$

where R is the resistor value in kΩ and t_{SU} is the resulting setup delay in seconds. For best results, use resistor values between 10kΩ and 500kΩ.

Reset Output

The reset output is typically connected to the reset input of a microprocessor (μP). A μP's reset input starts or restarts the μP in a known state. The MAX16122–MAX16125 μP supervisory circuits provide the reset logic to prevent code-execution errors during power-up, power-down, and brownout conditions (see the [Typical Operating Circuits](#)).

The MAX16122/MAX16123 have a reset output $\overline{\text{RESET}}$. The MAX16124/MAX16125 have a reset output $\overline{\text{RESET}}$ and a soft-reset output $\overline{\text{SRESET}}$ which is the debounced “mirror image” of $\overline{\text{MR}}$ (see [Figure 1a](#)).

MAX16122–MAX16125

Dual Pushbutton Controllers in Tiny 6-Bump WLP Package

All reset outputs are either active-low open-drain or active-low push-pull (see the [Selector Guide](#)). $\overline{\text{RESET}}$ changes from high to low whenever the monitored voltage V_{CC} drops below the reset threshold voltage. Once V_{CC} exceeds its respective reset threshold voltage, $\overline{\text{RESET}}$ remains low for the reset timeout period (t_{RP}) and then goes high. $\overline{\text{RESET}}$ is one-shot pulsed whenever selected manual reset inputs are asserted longer than the setup delay (t_{SU}). $\overline{\text{RESET}}$ stays asserted for the normal reset timeout period.

$\overline{\text{RESET}}$ is guaranteed to be in the proper output logic state for $V_{\text{CC}} \geq 0.95\text{V}$. For applications requiring valid reset logic when V_{CC} is less than 0.95V, see the [Ensuring a Valid \$\overline{\text{RESET}}\$ Output Down to \$V_{\text{CC}} = 0\text{V}\$ \(Push-Pull \$\overline{\text{RESET}}\$ Output\)](#) section.

Manual Reset Input

Each device in the MAX16122–MAX16125 family includes at least one manual reset input, which must be held logic-low for an extended setup period (t_{SU}) before the $\overline{\text{RESET}}$ output asserts. An internal pullup resistor is connected to each manual reset input. When valid manual reset input conditions/setup periods are met, the $\overline{\text{RESET}}$ output is

pulsed low for the reset timeout period (see [Table 2](#)). Existing front-panel pushbutton switches (i.e., power-on/off, channel up/down, or mode select) can be used to drive the manual reset inputs. The extended manual reset setup period prevents nuisance system resets during normal front-panel usage or resulting from inadvertent short-term pushbutton closure.

The MAX16124/MAX16125 include a single manual reset input ($\overline{\text{MR}}$) and two reset outputs ($\overline{\text{RESET}}$ and $\overline{\text{SRESET}}$). The MAX16122/MAX16123 include two manual reset inputs ($\overline{\text{MR1}}$ and $\overline{\text{MR2}}$) and one reset output, $\overline{\text{RESET}}$. For dual $\overline{\text{MR1}}$ and $\overline{\text{MR2}}$ devices, both inputs must be simultaneously pulled low and held for the extended setup period (t_{SU}) before the reset output is pulsed. The dual extended setup provides greater protection from nuisance resets.

The MAX16122–MAX16125 $\overline{\text{RESET}}$ output is asserted once for the reset timeout period after each valid manual reset input condition. At least one manual reset input must be released (go high) and then be driven low for the extended setup period before $\overline{\text{RESET}}$ asserts again. Internal timing circuitry debounces low-to-high manual reset logic transitions, so no external circuitry is required.

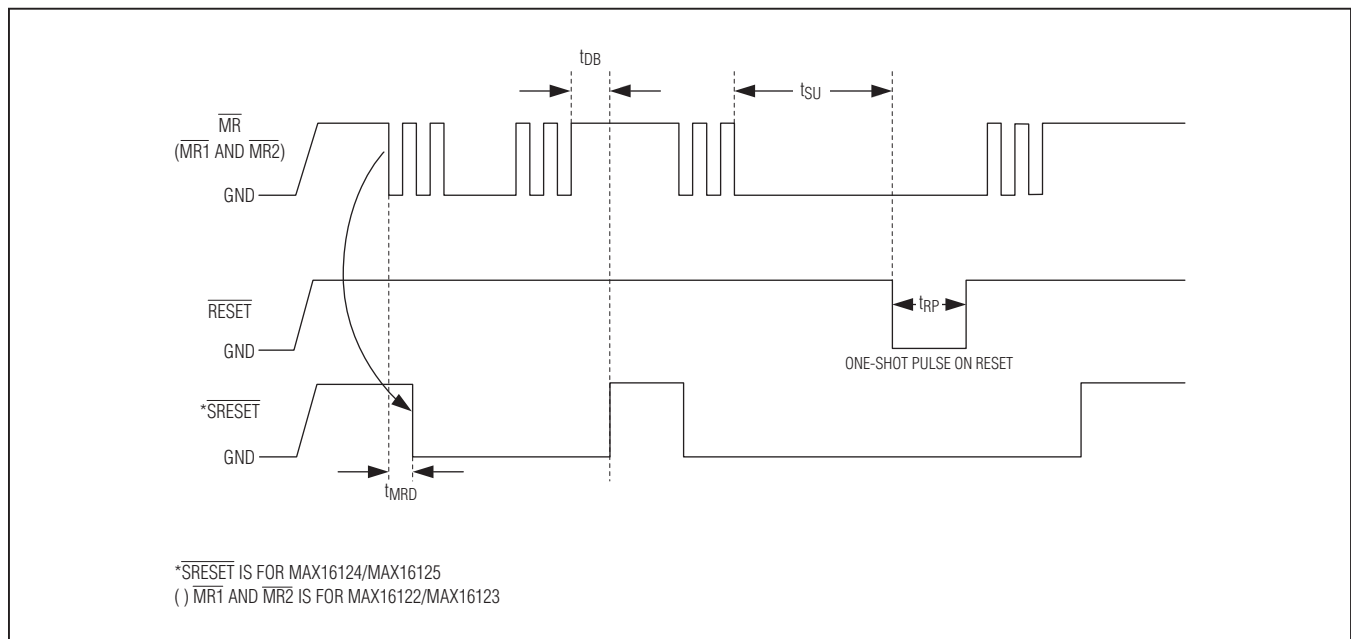

Figure 1a. Reset Timing Diagram

MAX16122–MAX16125

Dual Pushbutton Controllers in Tiny 6-Bump WLP Package

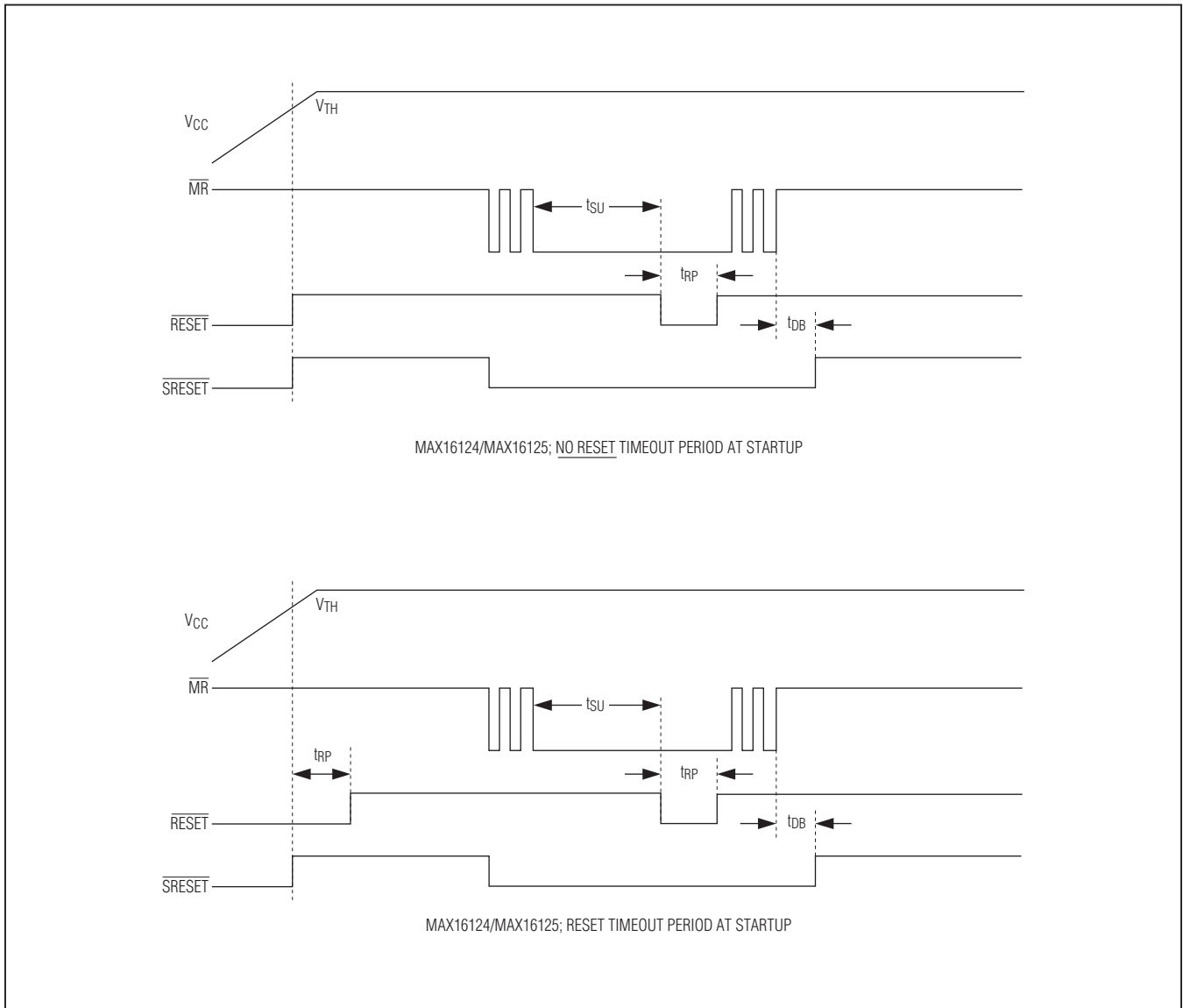

Figure 1b. Timeout Periods at Startup

MAX16122–MAX16125

Dual Pushbutton Controllers in Tiny 6-Bump WLP Package

Supply Voltage Monitor

The MAX16122–MAX16125 have an internal comparator with a programmable trip threshold to monitor the supply voltage. The V_{CC} monitoring thresholds are selectable through the part number suffix (see the [Ordering Information](#) and [Table 3](#)).

Applications Information

Falling V_{CC} Transients

In addition to issuing a reset to the μP during power-up, power-down, and brownout conditions, the MAX16122–MAX16125 are relatively immune to short-duration falling V_{CC} transients (glitches). The [Typical Operating Characteristics](#) show the Maximum Transient Duration vs. V_{CC} Overdrive graph for which the MAX16122–MAX16125 do not generate a reset pulse. This graph was generated using a falling pulse applied to V_{CC} starting above the actual reset threshold and ending below the threshold by the magnitude indicated (V_{CC} overdrive). The graph indicates the typical maximum pulse width that a falling transient can have without initiating a reset pulse. As the magnitude of the transient increases (go farther below the reset threshold), the maximum allowable pulse width decreases.

Ensuring a Valid $\overline{\text{RESET}}$ Output Down to $V_{CC} = 0\text{V}$ (Push-Pull $\overline{\text{RESET}}$ Output)

The MAX16122–MAX16125 guarantee proper operation down to $V_{CC} = 0.95\text{V}$. In applications that require valid reset levels down to $V_{CC} = 0\text{V}$, add a pulldown resistor between $\overline{\text{RESET}}$ and GND for the push-pull outputs (MAX16122/MAX16124). The resistor sinks any stray

leakage currents, holding $\overline{\text{RESET}}$ low ([Figure 2](#)). The resistor value used is not critical, but it must be small enough not to overload the $\overline{\text{RESET}}$ output when V_{CC} is above the reset threshold. For most applications, use $100\text{k}\Omega$ to $1\text{M}\Omega$. This scheme does not work with open-drain outputs of the MAX16123/MAX16125.

Layout and Bypassing

Ensure $0.1\mu\text{F}$ (minimum) capacitance is connected from V_{CC} to GND.

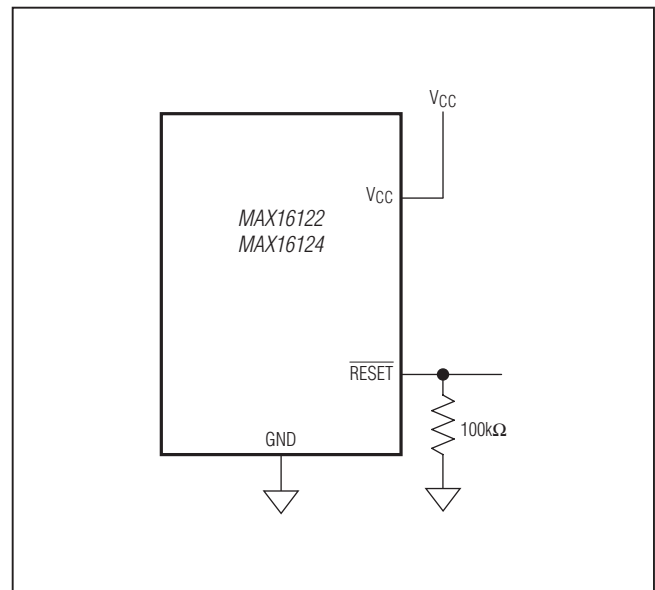
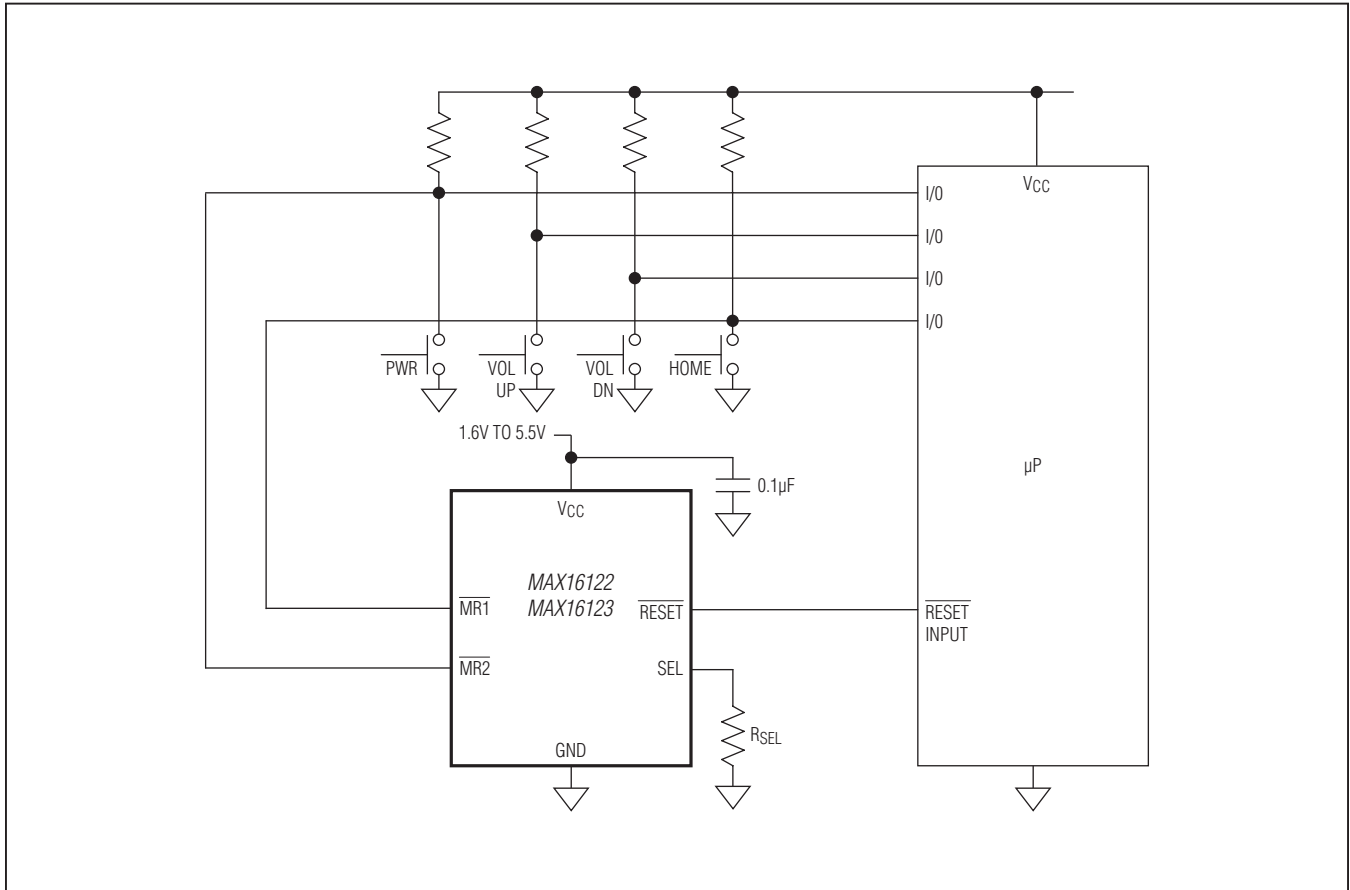

Figure 2. Ensuring $\overline{\text{RESET}}$ Output to $V_{CC} = 0\text{V}$

MAX16122–MAX16125

Dual Pushbutton Controllers in Tiny 6-Bump WLP Package

Typical Operating Circuits (continued)



MAX16122–MAX16125

Dual Pushbutton Controllers in Tiny 6-Bump WLP Package

Functional Diagrams

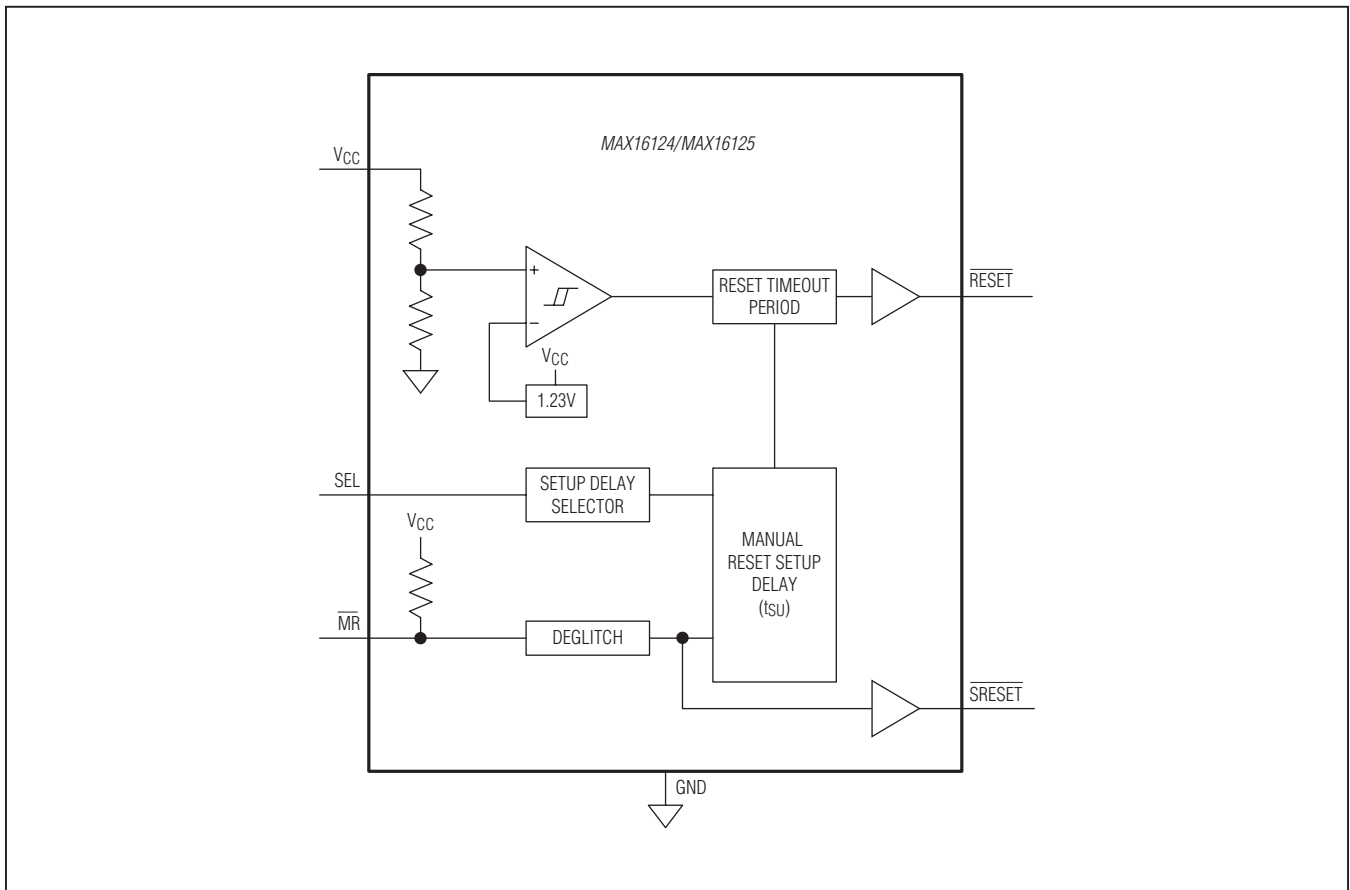

MAX16122–MAX16125

Dual Pushbutton Controllers in Tiny 6-Bump WLP Package

Functional Diagrams (continued)

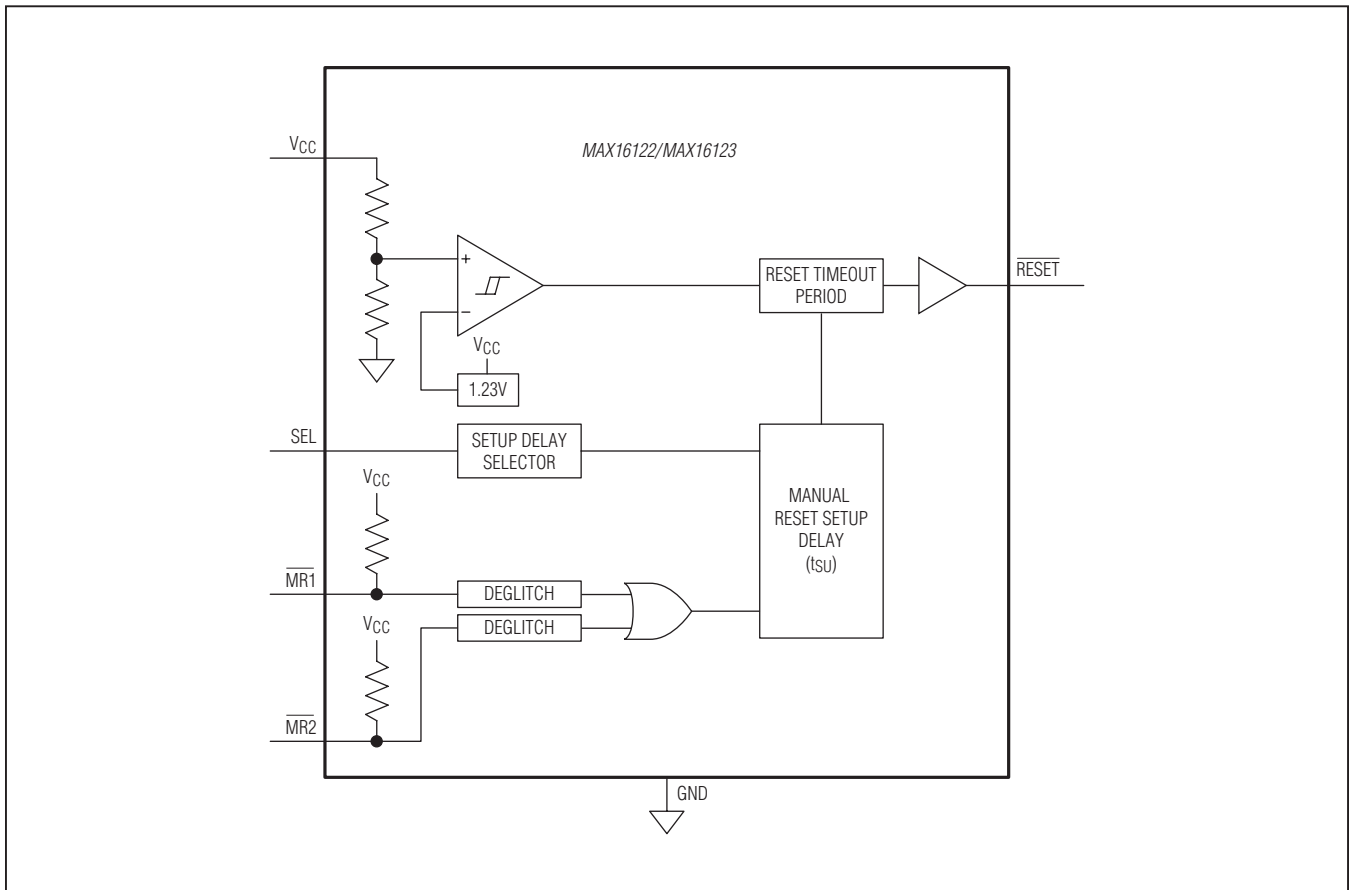

MAX16122–MAX16125

Dual Pushbutton Controllers in Tiny 6-Bump WLP Package

Table 1a. SEL Pin Connection Setup Delays (t_{SU})

PART SUFFIX	SETUP DELAYS (s)		
	SEL = GND	SEL = UNCONNECTED	SEL = V _{CC}
A	0.5	1	2
B	3	4	5
C	6	8	10
D	13	15	17
E	See Table 1b		

Table 1b. Resistor-Adjusted Setup Delays (t_{SU})

RESISTOR (kΩ)	SETUP DELAYS (s)
10	0.5
18	0.9
22	1.1
27	1.35
39	1.95
47	2.35
56	2.8
82	4.1
100	5
180	9
220	11

Table 2. Reset Timeouts (t_{RP})

PART SUFFIX	MINIMUM RESET TIMEOUT (ms)
A	0.9
B	1.8
C	3.6
D	7.2
E	14.4
F	28.8
G	57.6
H	86.4
I	115.2
J	172.8
K	230.4
L	259.2
M	345.6
N	460.8
O	691.2
P	921.6
Q	1843.2
R	3686.4
S	7372.8

Table 3. V_{CC} Reset Threshold Voltage (V_{TH})

SUFFIX	V _{CC} RESET THRESHOLD VOLTAGE (V) (typ)
00	No Monitoring
16	1.58
17	1.67
22	2.19
23	2.32
29	2.93
31	3.08
44	4.38
46	4.63

MAX16122–MAX16125

Dual Pushbutton Controllers in Tiny 6-Bump WLP Package

Ordering Information

PART	TEMP RANGE	PIN-PACKAGE
MAX16122WT____+T*	-40°C to +125°C	6 WLP
MAX16123WT____+T*	-40°C to +125°C	6 WLP
MAX16124WT____+T*	-40°C to +125°C	6 WLP
MAX16125WT____+T	-40°C to +125°C	6 WLP

Note: Insert the desired setup delay (A to Q, from [Table 1a](#)) into the blank following the letters WT. Insert the letter corresponding to the desired minimum reset timeout period (A to S, from [Table 2](#)) into the blank following the setup delay suffix. Insert the two digit number corresponding to the desired nominal reset threshold (from [Table 3](#)) into the blanks following the reset timeout suffix.

+Denotes a lead(Pb)-free/RoHS-compliant package. Devices are available only in lead-free packaging.

T = Tape and reel.

*Future product—Contact factory for availability.

Selector Guide

PART	DUAL MANUAL RESET INPUT	$\overline{\text{SRESET}}$	SEL	ACTIVE-LOW RESET OUTPUT
MAX16122WT____+T	√	—	√	Push-pull
MAX16123WT____+T	√	—	√	Open-drain
MAX16124WT____+T	—	√	√	Push-Pull
MAX16125WT____+T	—	√	√	Open-drain

Note: MAX16125WTDB29+T is a standard option. For additional options, please contact factory.

Chip Information

PROCESS: BiCMOS

Package Information

For the latest package outline information and land patterns (footprints), go to www.maximintegrated.com/packages. Note that a "+", "#", or "-" in the package code indicates RoHS status only. Package drawings may show a different suffix character, but the drawing pertains to the package regardless of RoHS status.

PACKAGE TYPE	PACKAGE CODE	OUTLINE NO.	LAND PATTERN NO.
WLP	W61F0+1	21-0217	Refer to Application Note 1891

MAX16122–MAX16125

Dual Pushbutton Controllers in Tiny 6-Bump WLP Package

Revision History

REVISION NUMBER	REVISION DATE	DESCRIPTION	PAGES CHANGED
0	7/12	Initial release	—
1	11/14	No IV OPNs in <i>Ordering Information</i> ; removed automotive reference from <i>Applications</i> section	1



Maxim Integrated cannot assume responsibility for use of any circuitry other than circuitry entirely embodied in a Maxim Integrated product. No circuit patent licenses are implied. Maxim Integrated reserves the right to change the circuitry and specifications without notice at any time. The parametric values (min and max limits) shown in the Electrical Characteristics table are guaranteed. Other parametric values quoted in this data sheet are provided for guidance.

Maxim Integrated 160 Rio Robles, San Jose, CA 95134 USA 1-408-601-1000

16



Стандарт Электрон Связь

Мы молодая и активно развивающаяся компания в области поставок электронных компонентов. Мы поставляем электронные компоненты отечественного и импортного производства напрямую от производителей и с крупнейших складов мира.

Благодаря сотрудничеству с мировыми поставщиками мы осуществляем комплексные и плановые поставки широчайшего спектра электронных компонентов.

Собственная эффективная логистика и склад в обеспечивает надежную поставку продукции в точно указанные сроки по всей России.

Мы осуществляем техническую поддержку нашим клиентам и предпродажную проверку качества продукции. На все поставляемые продукты мы предоставляем гарантию .

Осуществляем поставки продукции под контролем ВП МО РФ на предприятия военно-промышленного комплекса России , а также работаем в рамках 275 ФЗ с открытием отдельных счетов в уполномоченном банке. Система менеджмента качества компании соответствует требованиям ГОСТ ISO 9001.

Минимальные сроки поставки, гибкие цены, неограниченный ассортимент и индивидуальный подход к клиентам являются основой для выстраивания долгосрочного и эффективного сотрудничества с предприятиями радиоэлектронной промышленности, предприятиями ВПК и научно-исследовательскими институтами России.

С нами вы становитесь еще успешнее!

Наши контакты:

Телефон: +7 812 627 14 35

Электронная почта: sales@st-electron.ru

Адрес: 198099, Санкт-Петербург,
Промышленная ул, дом № 19, литера Н,
помещение 100-Н Офис 331