

10135262 - 10X LF

LEAD-FREE DESIGNATION ONLY WITH APPLICABLE PLATING CODES

SEE NOTE 2

MODULE DESCRIPTION

LETTER DESIGNATION REPRESENTED IN DASH NUMBER

BASE MODULE

RIGHT POLARIZING GUIDANCE MODULE (SEE SHEET 3)

NO KEY NO GUIDE PIN

N	J (NO KEY)	A	B	C	D	E	F	G	H

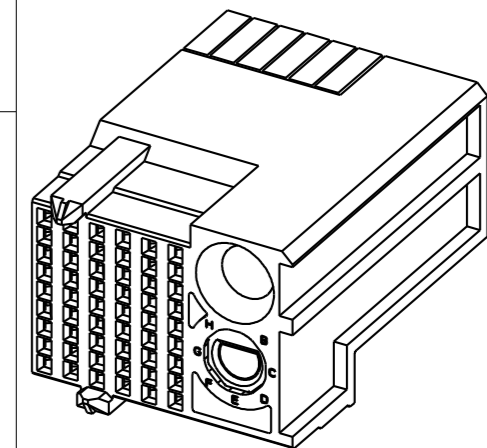

LEFT POLARIZING GUIDANCE MODULE (SEE SHEET 2)

NO KEY NO GUIDE PIN

Z	Y (NO KEY)	P	Q	R	S	T	U	V	W

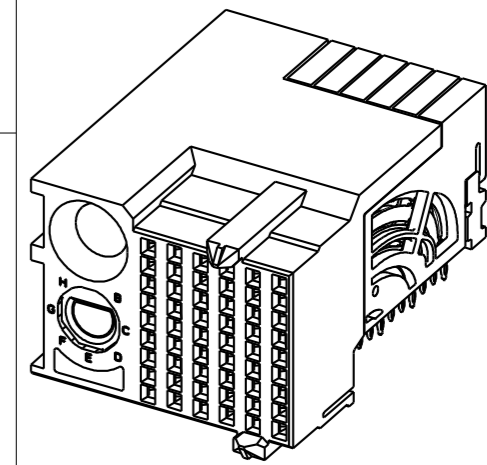

spec ref	---	dr	Jeny Ren	2015/05/20	projection	MM	size	A2	scale	8:1												
tolerance std	ASME Y14.5M	eng	Terry Luo	2019/01/31			ecn no	-	rel level	Released												
TOLERANCES UNLESS OTHERWISE SPECIFIED		chr	Stone Li	2019/01/31																		
surface	<table border="1"> <tr> <td>linear</td> <td>0.X</td> <td>±.3</td> </tr> <tr> <td></td> <td>0.XX</td> <td>±.15</td> </tr> <tr> <td></td> <td>0.XXX</td> <td>±.050</td> </tr> <tr> <td>angular</td> <td>0°</td> <td>±°</td> </tr> </table>	linear	0.X	±.3		0.XX	±.15		0.XXX	±.050	angular	0°	±°	appr	Heaven Cen	2019/01/31	product family	AirMax VS2	rel level	Released	rev	A
linear	0.X	±.3																				
	0.XX	±.15																				
	0.XXX	±.050																				
angular	0°	±°																				
		Amphenol FCI		AIRMAX VSE R.A. RECEPTACLE		ASS'Y, 3 PAIR, 54 POS, 6 IMLA, 20MM, W/GUIDE/KEY		10135262		sheet 1 of 4												
cat. no.		-		Product - Customer Drw		-		-		-												

Amphenol FCI

© 2016 AFCI

LEFT POLARIZATION WITH GUIDE

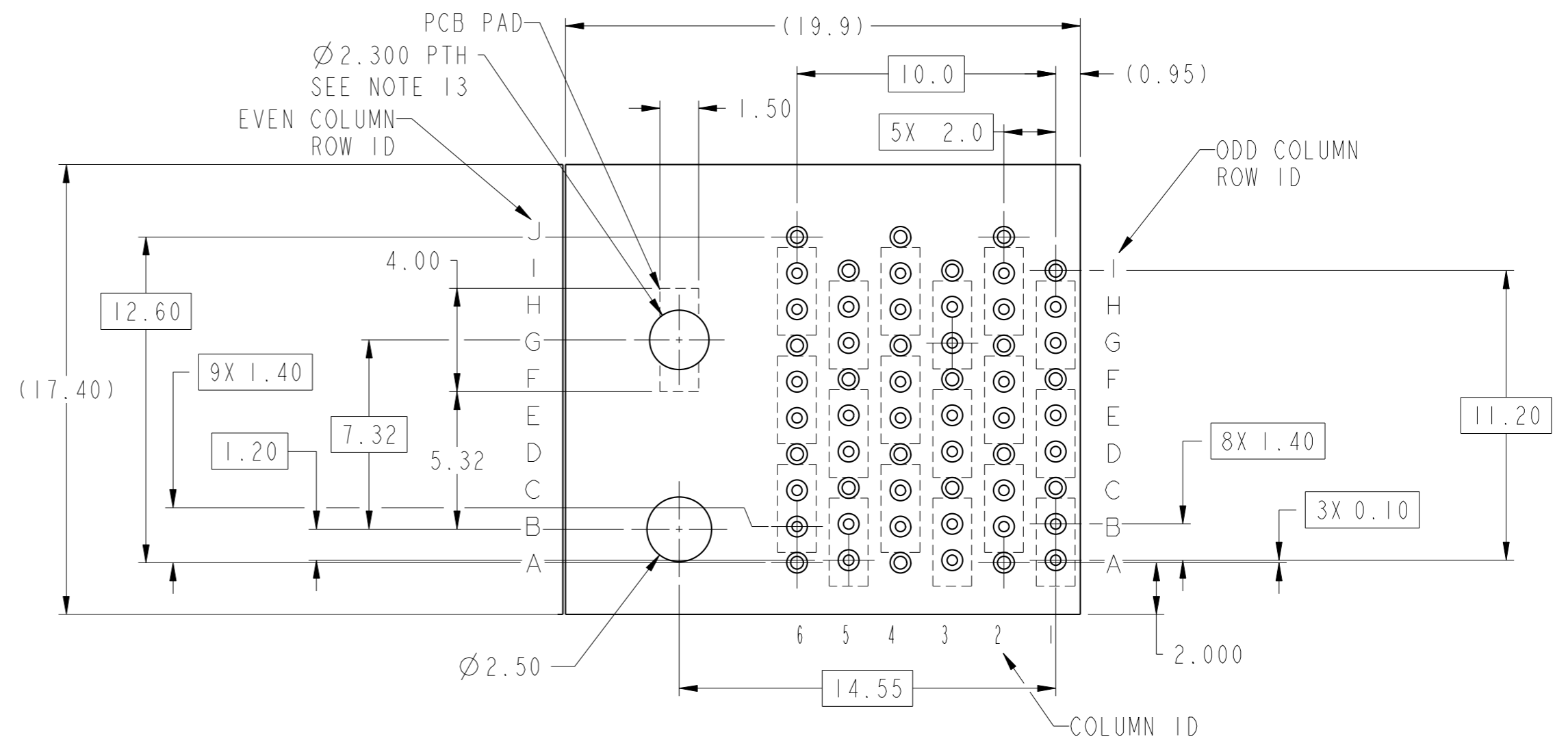
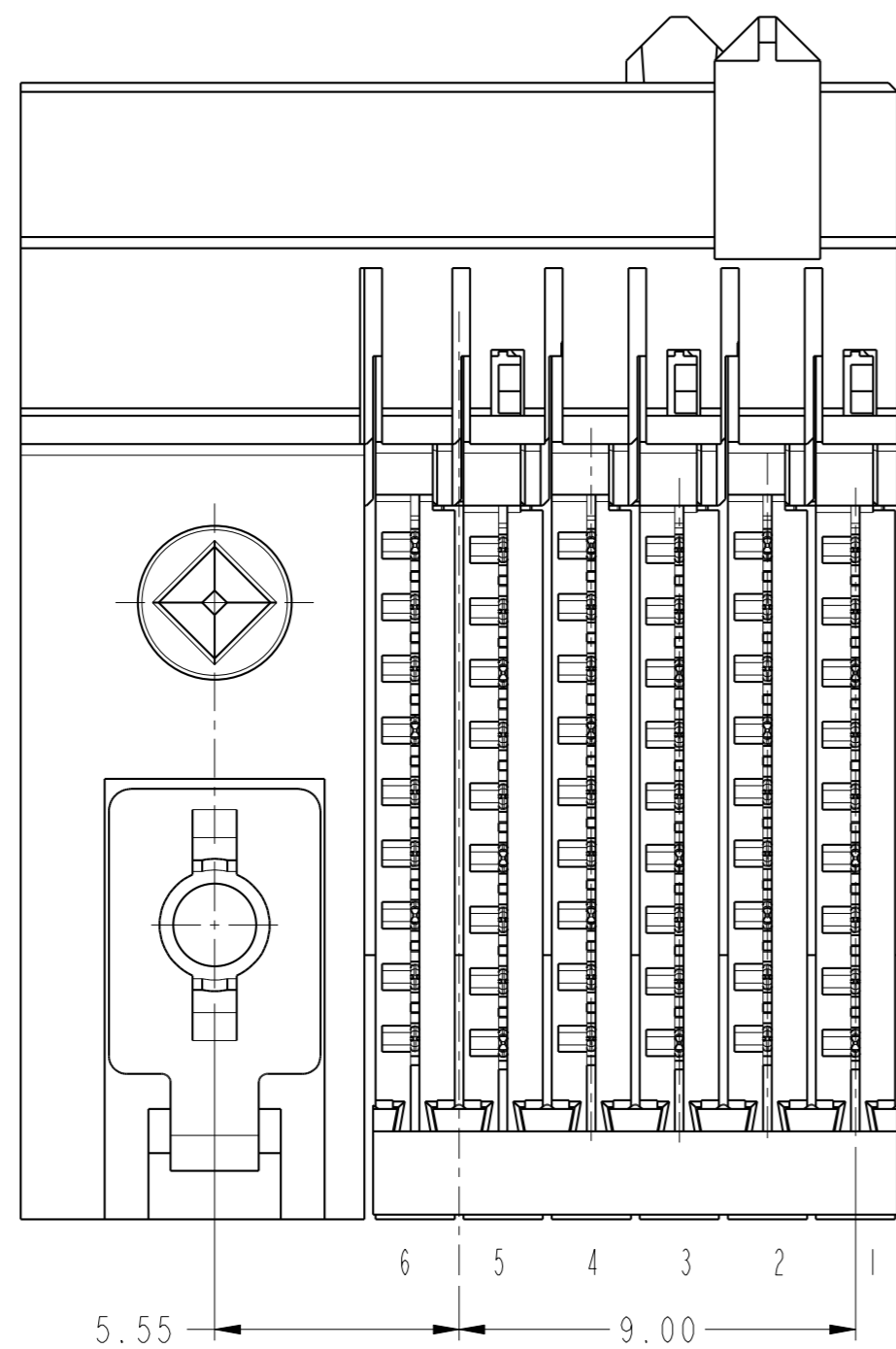
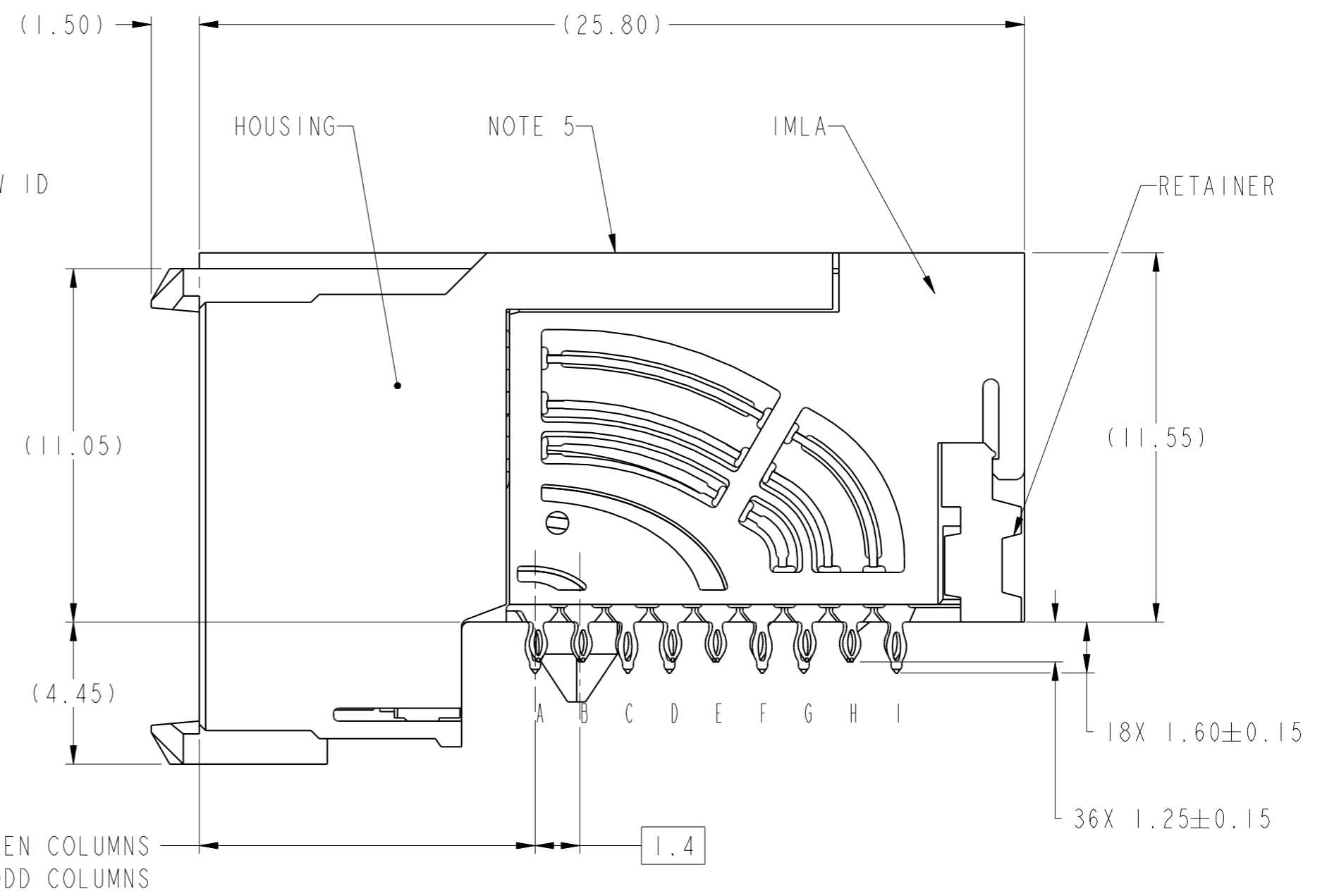
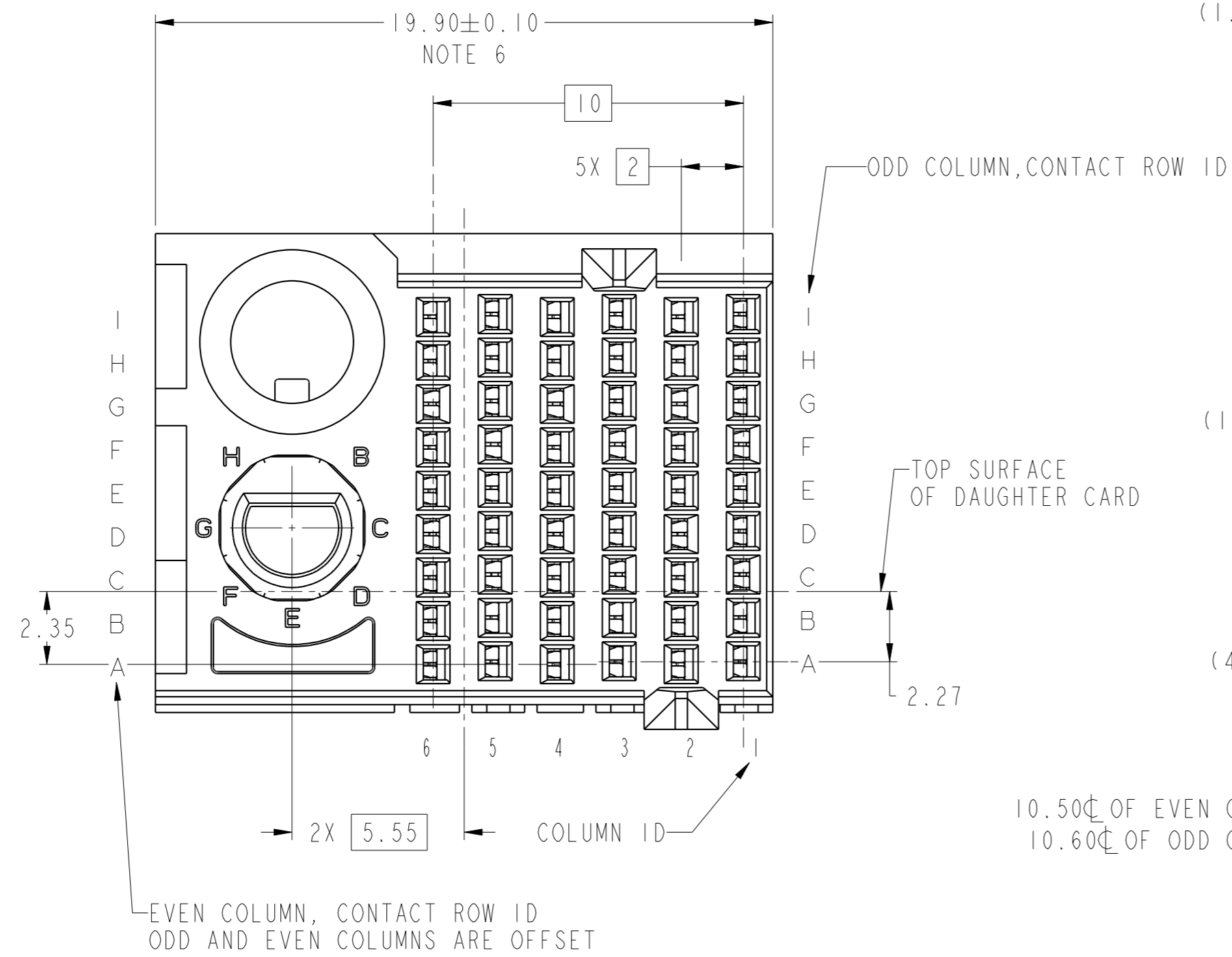

RECOMMENDED PCB LAYOUT

spec ref	---	dr	Jeny Ren	2015/05/20	projection	MM	size	A2	scale	6:1
tolerance std	ASME Y14.5M	eng	Terry Luo	2019/01/31			ecn no	-	rel level	Released
TOLERANCES UNLESS OTHERWISE SPECIFIED		chr	Stone Li	2019/01/31						
surface	linear	0.X	±.3		product family	AirMax VS2	title AIRMAX VSE R.A. RECEPTACLE ASS'Y, 3 PAIR, 54 POS, 6 IMLA, 20MM, W/GUIDE/KEY cat. no.	dwg no 10135262	rev A	
		0.XX	±.15		Product - Customer Drw	sheet 2 of 4				
	angular	0°	±°							

PDS: Rev :A

STATUS:Released

Printed: Jan 31, 2019

Amphenol
FCI

© 2016 AFCI

RIGHT POLARIZATION WITH GUIDE

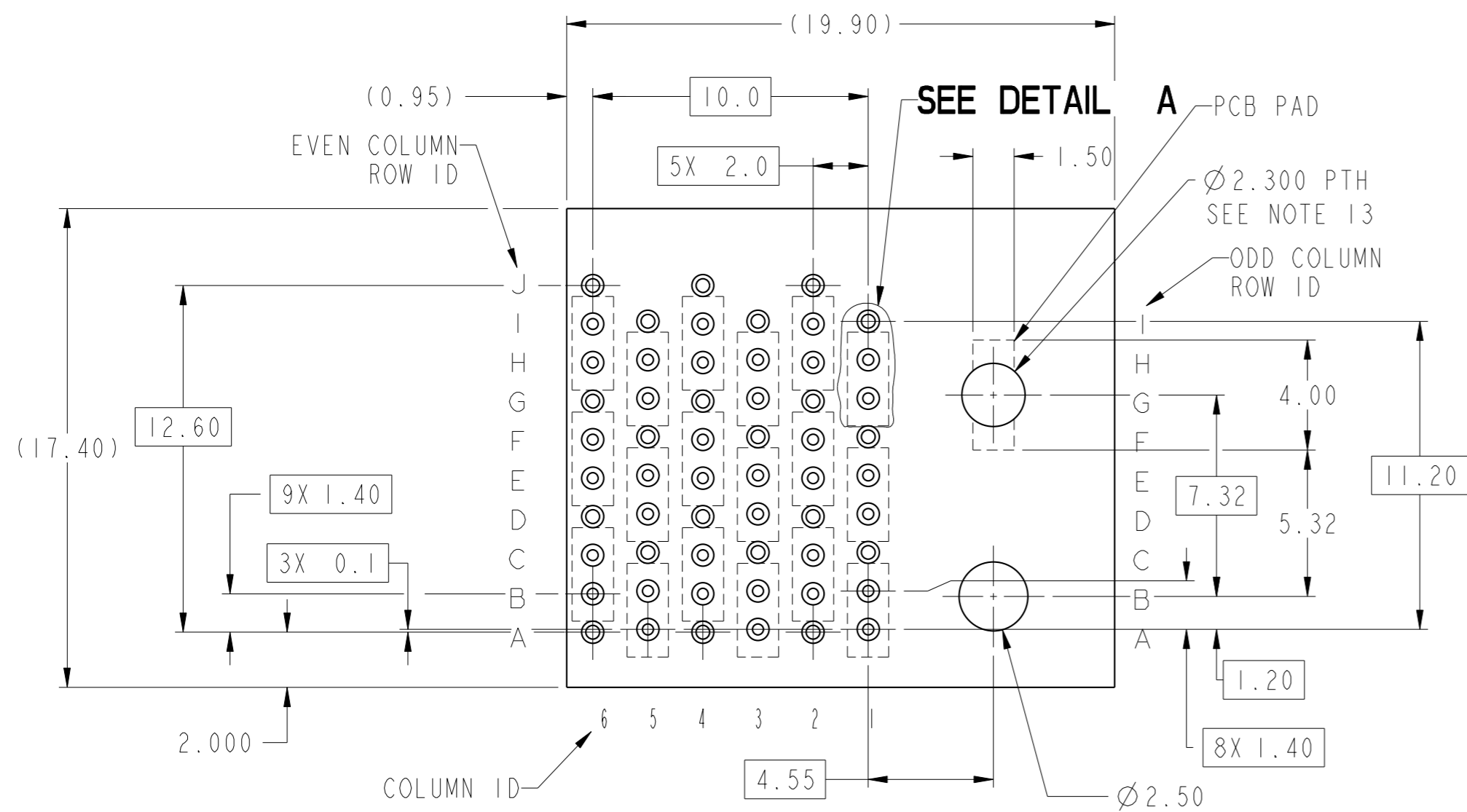
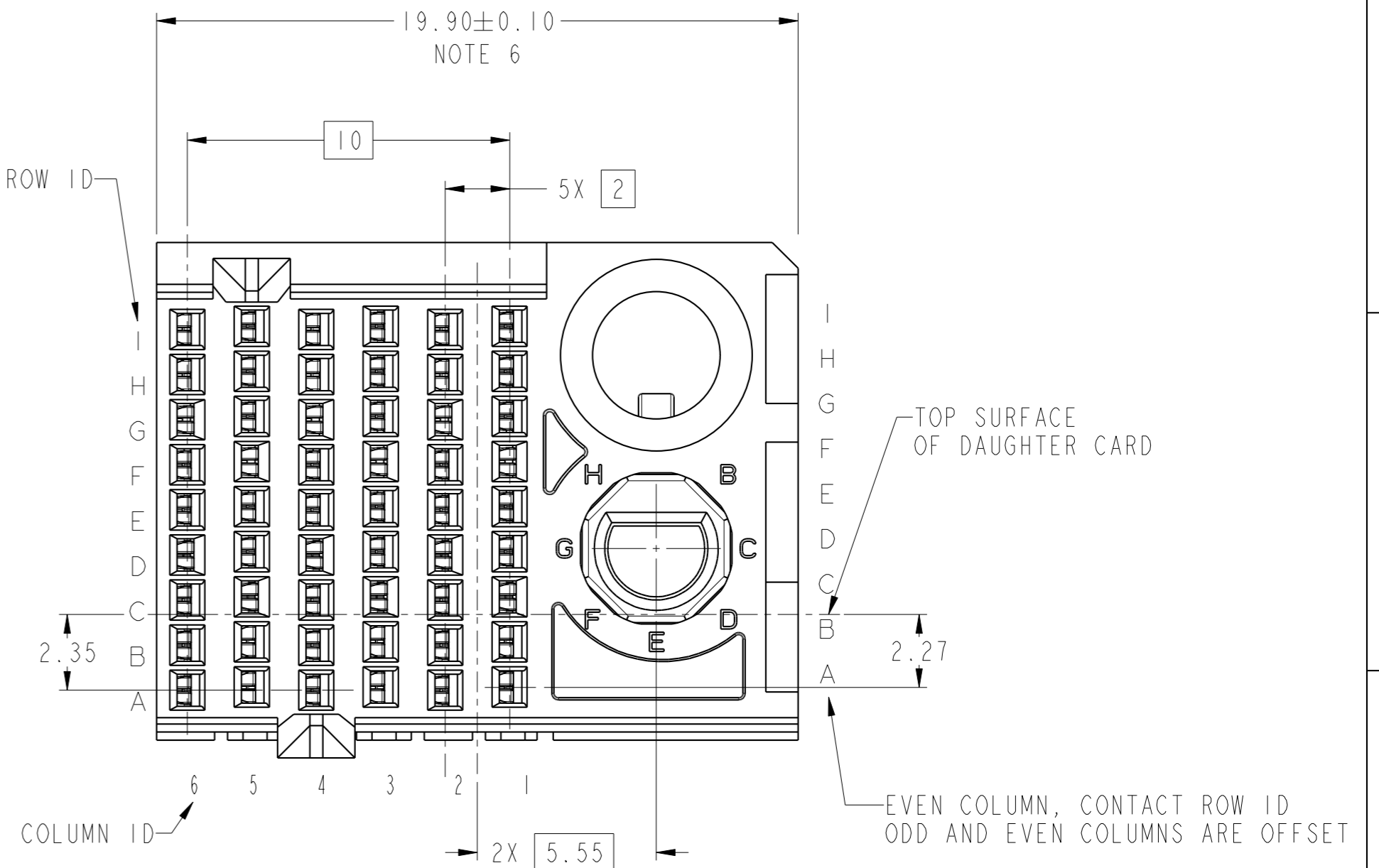
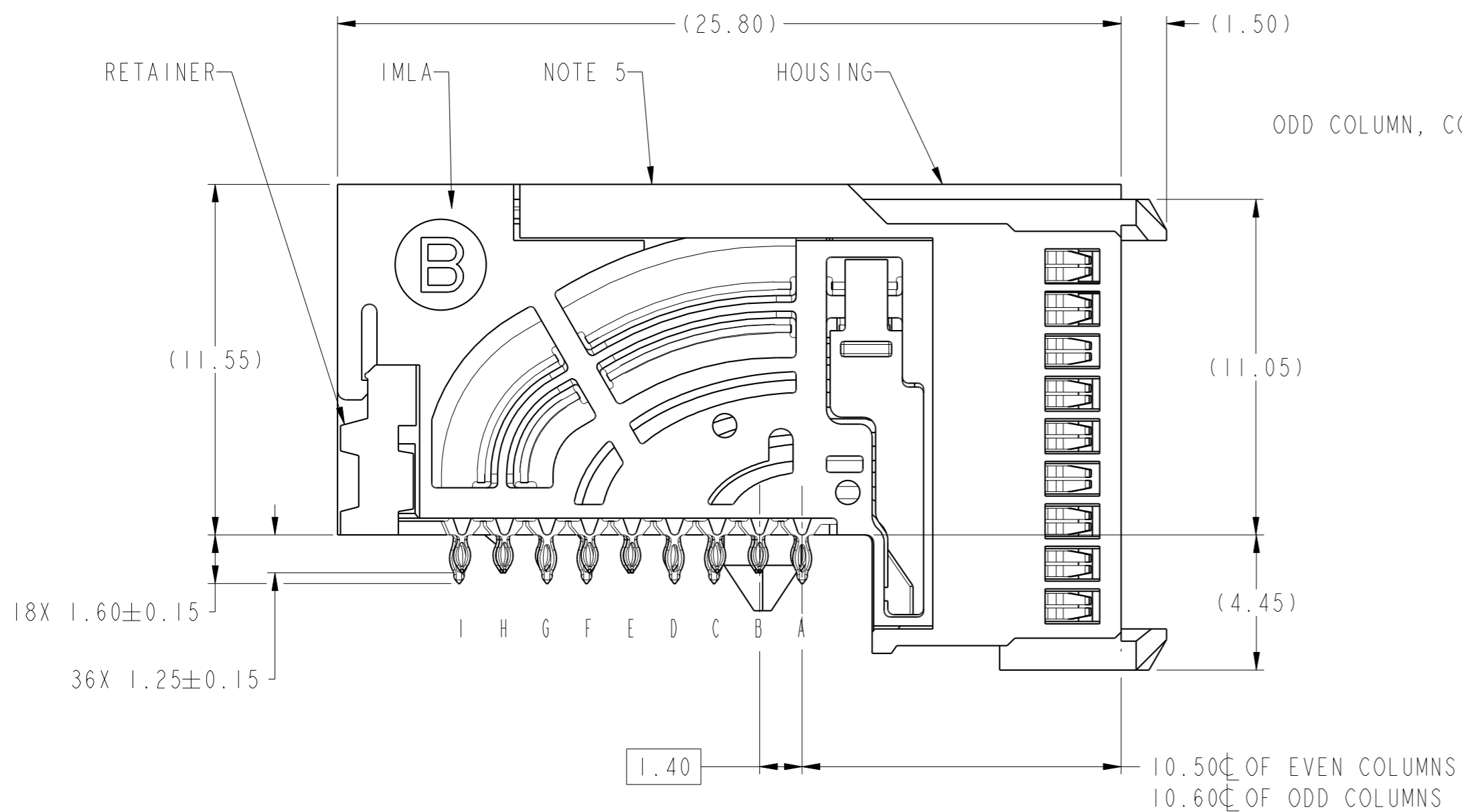

RECOMMENDED PCB LAYOUT

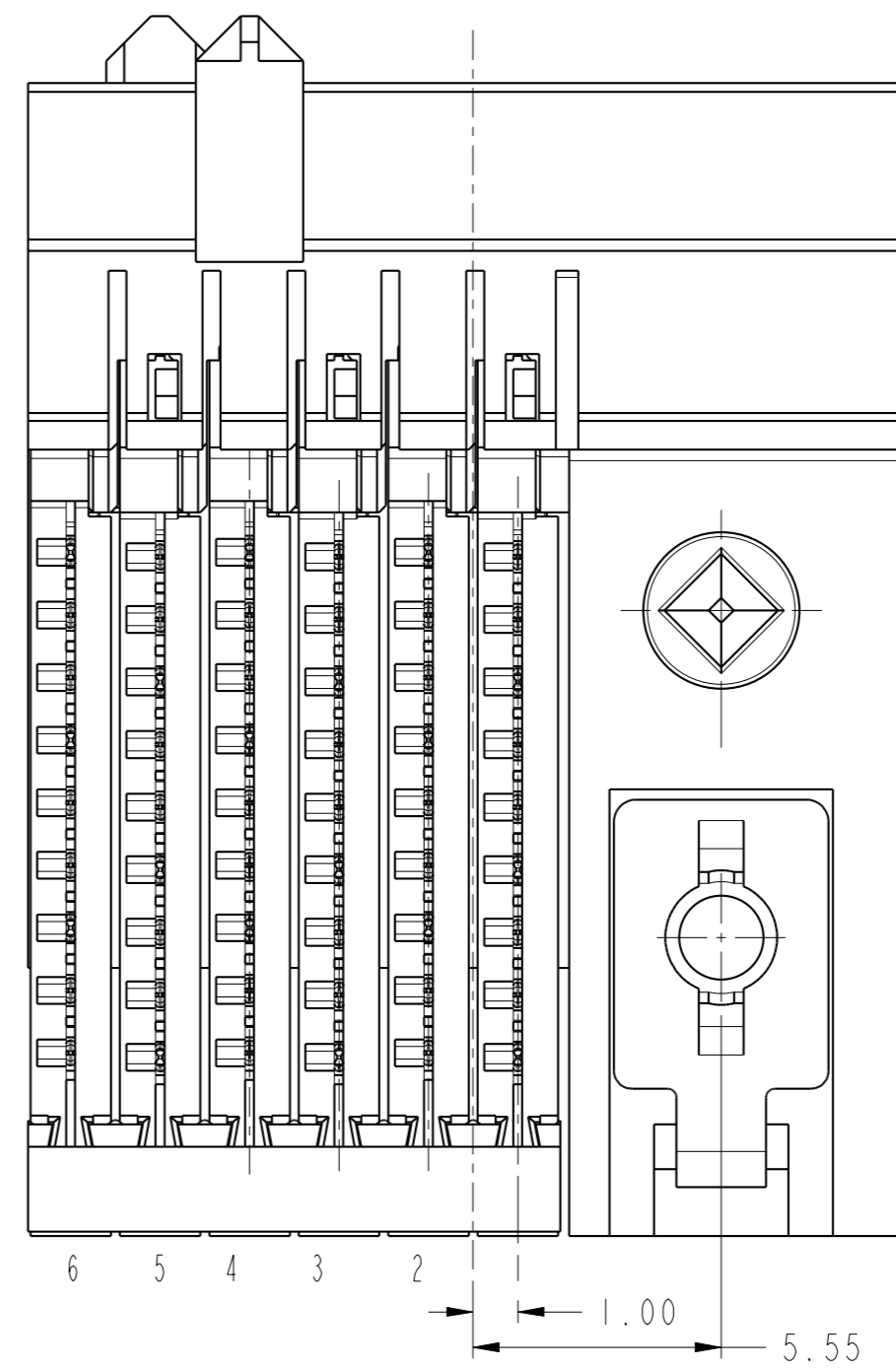

spec ref	---	dr	Jeny Ren	20150520	projection	MM	size	A2	scale	8:1
tolerance std	ASME Y14.5M	eng	Terry Luo	2019/01/31			ecn no	-	rel level	Released
TOLERANCES UNLESS OTHERWISE SPECIFIED		chr	Stone Li	2019/01/31						
surface	linear	0.X	±.3		product family	AIRMAX VS2	title AIRMAX VSE R.A. RECEPTACLE ASS'Y, 3 PAIR, 54 POS, 6 IMLA, 20MM, W/GUIDE/KEY cat. no.	dwg no 10135262	rev A	
		0.XX	±.15		Product - Customer Draw	sheet 3 of 4				
		0.XXX	±.050							
	angular	0°	±°							

PDS: Rev :A

STATUS:Released

Printed: Jan 31, 2019

Amphenol FCI

© 2016 AFCI

PRODUCT NUMBER	PRESS-FIT TAIL PLATING TYPE
10135262-10*LF	TIN OVER NICKEL (LEAD FREE)

A

B

C

D

E

F

- 1 - CONNECTOR MATERIALS:
HOUSING: HIGH TEMP THERMOPLASTIC, NATURAL, UL94-V0
IMLA PLASTIC: HIGH TEMP THERMOPLASTIC, BLACK, UL94-V0
CONTACT: COPPER ALLOY
ORGANIZER: HIGH TEMP THERMOPLASTIC, WHITE, UL94-V0
- 2 - CONTACT PLATING:
SEPARABLE INTERFACE:
PERFORMANCE-BASED PLATING, QUALIFIED TO MEET THE REQUIREMENTS OF FCI PRODUCT SPECIFICATION GS-12-0956 INCLUDING TELCORDIA GR-1217-CORE (NOVEMBER 1995) CENTRAL OFFICE TEST SEQUENCE
- PRESS-FIT TAILS: SEE TABLE

- 3 - PRODUCT SPECIFICATION: GS-12-0956
- 4 - APPLICATION SPECIFICATION: GS-20-0305.
- 5 - PRODUCT MARKING, (PART NUMBER & LOT CODE), ON THIS SURFACE.
- 6 - THE MINIMUM CENTERLINE SPACING BETWEEN ADJACENT MODULES IS 20.0 MM.
- 7 - CONNECTOR OUTLINE MAY BE SCREEN PRINTED ONTO CUSTOMER PCB TO BE USED AS A GUIDE FOR MANUAL CONNECTOR PLACEMENT.
- 8 - REFER TO CUSTOMER DRAWING 10104444 FOR INFORMATION ON PCB HOLE DIAMETERS AND PLATING OPTIONS
- 9 - LEAD FREE PRODUCT MEETS THE EUROPEAN UNION DIRECTIVES & OTHER COUNTRY REGULATIONS AS DESCRIBED IN GS-22-008
- 10 - PACKAGING MEETS GS-14-920 LEAD FREE LABELING SPECIFICATION.
- 11 - GROUND CONTACTS (C, F, AND I IN ODD COLUMNS AND A, D, AND G, EVEN COLUMNS) REQUIRE ($\varnothing 0.500$) FINISHED HOLES. SIGNAL LOCATIONS REQUIRE ($\varnothing 0.400$) FINISHED HOLES.
- 12 - THESE OUTER VIAS (J) ARE OPTIONAL. WHILE NO CONNECTOR EONS ARE PRESSED INTO THESE HOLES WE RECOMMEND ($\varnothing 0.500$) FINISHED HOLES AT THESE LOCATIONS TO PROVIDE GROUND SYMMETRY THROUGH THE PCB.
- 13 - CUSTOMER CAN FIX THE CONNECTOR WITH THREAD FORMING SCREW THROUGH THIS PTH. THE SCREW IS #2-32, THE VALID LENGTH OF SCREW IS 4.5MM PLUS THE THICKNESS OF PCB.

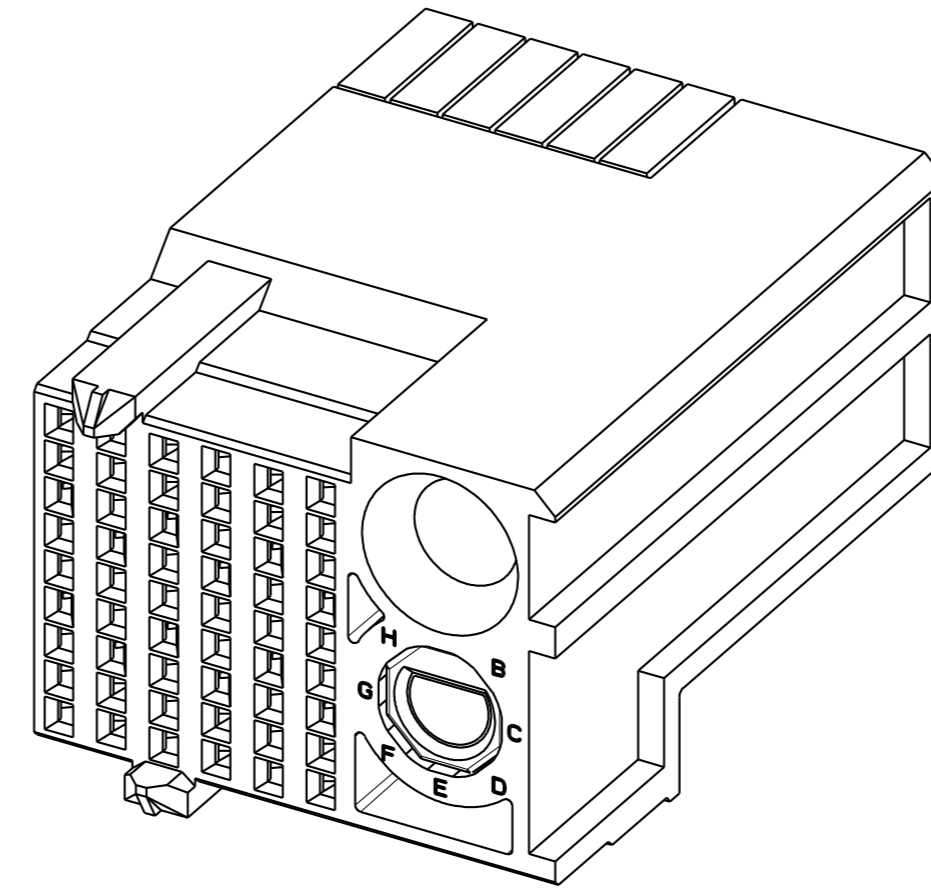

10135262-10ALF

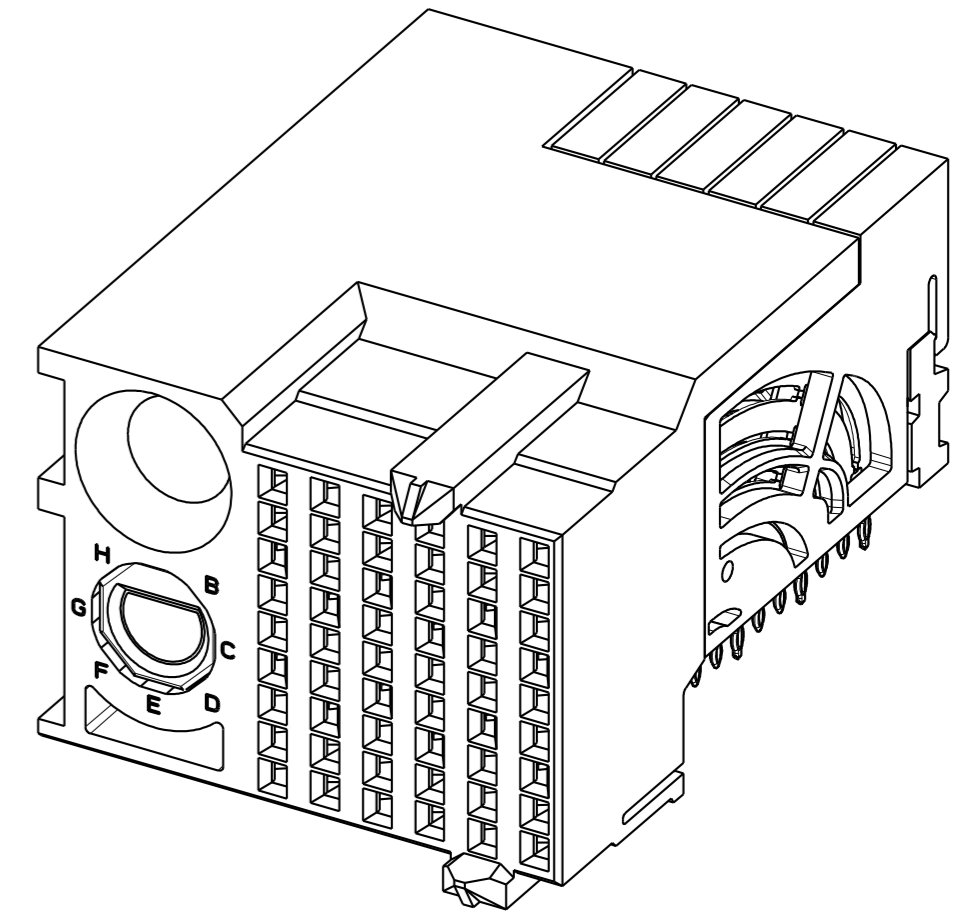

10135262-10PLF

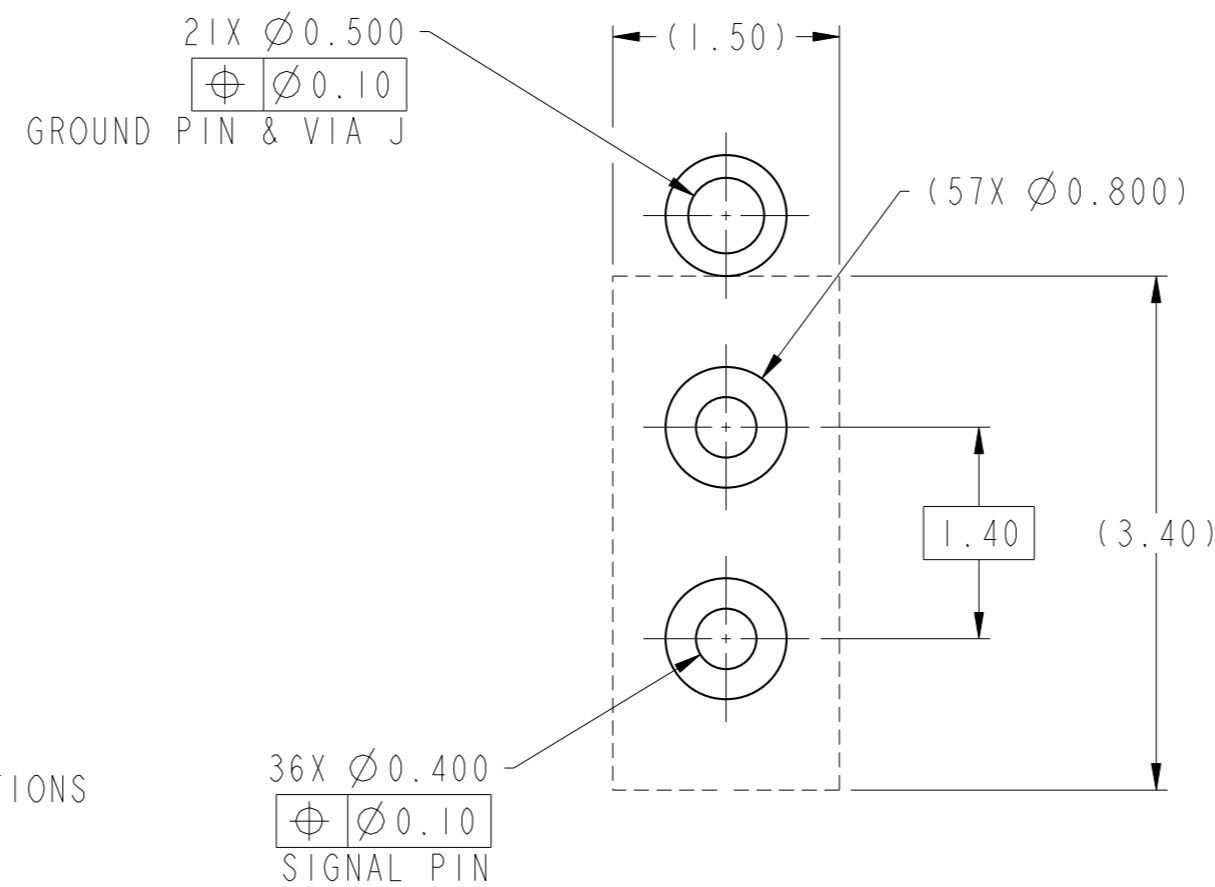
DETAIL A
SCALE 20:1

spec ref	---	dr	Jeny Ren	2015/05/20	projection	MM	size	A2	scale	6:1
tolerance std	ASME Y14.5M	eng	Terry Luo	2019/01/31			ecn no	-	rel level	Released
TOLERANCES UNLESS OTHERWISE SPECIFIED		chr	Stone Li	2019/01/31						
surface	linear	0.X	±.3		product family	AirMax VS2	title AIRMAX VSE R.A. RECEPTACLE ASS'Y, 3 PAIR, 54 POS, 6 IMLA, 20MM, W/GUIDE/KEY	dwg no 10135262	rev A	
		0.XX	±.15		cat. no.	-				
		0.XXX	±.050		Product - Customer Drw	sheet 4 of 4				
	angular	0°	±°							



Стандарт Электрон Связь

Мы молодая и активно развивающаяся компания в области поставок электронных компонентов. Мы поставляем электронные компоненты отечественного и импортного производства напрямую от производителей и с крупнейших складов мира.

Благодаря сотрудничеству с мировыми поставщиками мы осуществляем комплексные и плановые поставки широчайшего спектра электронных компонентов.

Собственная эффективная логистика и склад в обеспечивает надежную поставку продукции в точно указанные сроки по всей России.

Мы осуществляем техническую поддержку нашим клиентам и предпродажную проверку качества продукции. На все поставляемые продукты мы предоставляем гарантию .

Осуществляем поставки продукции под контролем ВП МО РФ на предприятия военно-промышленного комплекса России , а также работаем в рамках 275 ФЗ с открытием отдельных счетов в уполномоченном банке. Система менеджмента качества компании соответствует требованиям ГОСТ ISO 9001.

Минимальные сроки поставки, гибкие цены, неограниченный ассортимент и индивидуальный подход к клиентам являются основой для выстраивания долгосрочного и эффективного сотрудничества с предприятиями радиоэлектронной промышленности, предприятиями ВПК и научно-исследовательскими институтами России.

С нами вы становитесь еще успешнее!

Наши контакты:

Телефон: +7 812 627 14 35

Электронная почта: sales@st-electron.ru

Адрес: 198099, Санкт-Петербург,
Промышленная ул, дом № 19, литера Н,
помещение 100-Н Офис 331