

ADA4899-1 Rail-to-Rail SAR ADC Driver Amplifier

DESCRIPTION

Demonstration circuit 2622A features the ADA4899-1 amplifier. The DC2622A includes two of these amplifiers and is designed to drive the inputs of the DC2290 demo board. The DC2290 features the **LTC®2387** 18-bit, 15Msps high speed SAR ADC. The linearity and low noise of the ADA4899-1 make it an ideal candidate to drive the LTC2387 at frequencies above 1MHz. See Table 1.

The DC2622A is configured to accept a single-ended input signal and provide unity gain. The board can provide voltage gain if several component values are changed. For

example, a voltage gain of two will result if the following changes are made:

- Change R23 to 309Ω
- Install 309Ω at R27
- Install 100pF at C28
- Change R18 to 287Ω

Design files for this circuit board are available at <http://www.linear.com/demo/DC2622A>

LT, LTC, LTM, Linear Technology and the Linear Logo are registered trademarks of Analog Devices, Inc. All other trademarks are the property of their respective owners.

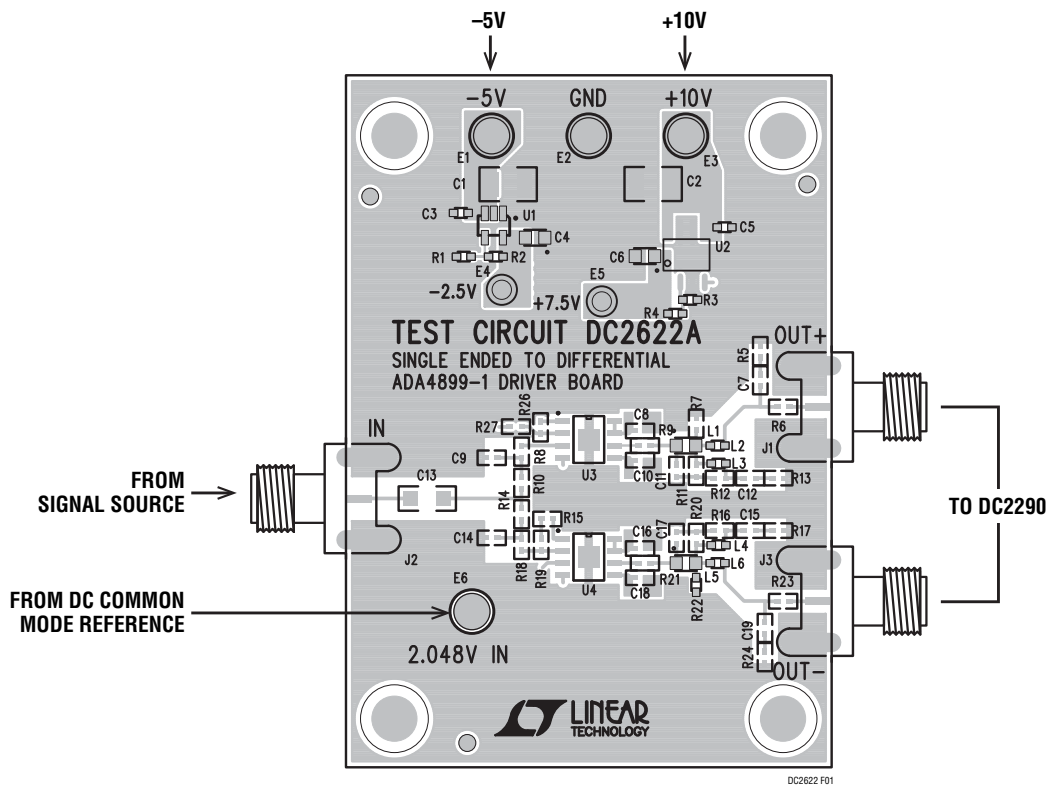

Figure 1. DC2622A Connection Diagram

Table 1. DC2290 (LTC2387 Family) Driver Boards

INPUT FREQUENCY	DRIVER BOARD	AMPLIFIER
Up to 8kHz	DC2402	LT6237
Up to 1MHz	DC2403	LT6200
>1MHz	Lowest Noise — DC2622 Lowest Distortion — DC2623	ADA4899-1 LTC6404-1 + AD8002

DEMO MANUAL DC2622A

QUICK START PROCEDURE

Connect the DC2622A to a DC2290A using the two output SMA connectors J1, J3. Connect the +10V and -5V DC supplies to the turrets on the DC2622A. Apply a 2.048V

DC voltage, preferably from E7 of the DC2290A, to 2.048V in turret of the DC2622A.

HARDWARE SETUP

SIGNAL CONNECTIONS

J2 IN. This is the signal input.

J3 -OUT. This is the negative signal output.

J1 +OUT. This is the positive signal output.

SCHEMATIC DIAGRAM

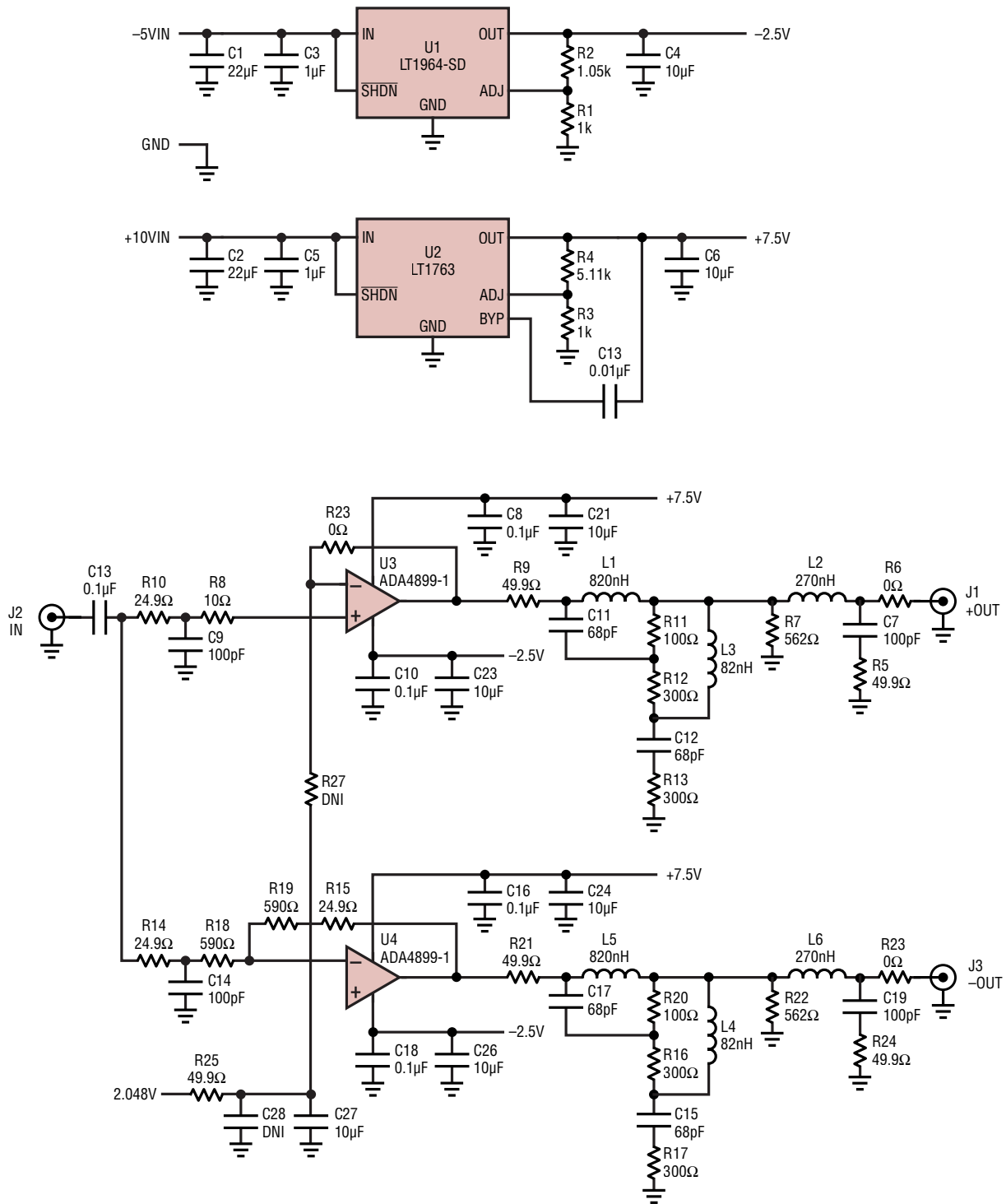

DEMO MANUAL DC2622A

DEMONSTRATION BOARD IMPORTANT NOTICE

Linear Technology Corporation (LTC) provides the enclosed product(s) under the following **AS IS** conditions:

This demonstration board (DEMO BOARD) kit being sold or provided by Linear Technology is intended for use for **ENGINEERING DEVELOPMENT OR EVALUATION PURPOSES ONLY** and is not provided by LTC for commercial use. As such, the DEMO BOARD herein may not be complete in terms of required design-, marketing-, and/or manufacturing-related protective considerations, including but not limited to product safety measures typically found in finished commercial goods. As a prototype, this product does not fall within the scope of the European Union directive on electromagnetic compatibility and therefore may or may not meet the technical requirements of the directive, or other regulations.

If this evaluation kit does not meet the specifications recited in the DEMO BOARD manual the kit may be returned within 30 days from the date of delivery for a full refund. **THE FOREGOING WARRANTY IS THE EXCLUSIVE WARRANTY MADE BY THE SELLER TO BUYER AND IS IN LIEU OF ALL OTHER WARRANTIES, EXPRESSED, IMPLIED, OR STATUTORY, INCLUDING ANY WARRANTY OF MERCHANTABILITY OR FITNESS FOR ANY PARTICULAR PURPOSE. EXCEPT TO THE EXTENT OF THIS INDEMNITY, NEITHER PARTY SHALL BE LIABLE TO THE OTHER FOR ANY INDIRECT, SPECIAL, INCIDENTAL, OR CONSEQUENTIAL DAMAGES.**

The user assumes all responsibility and liability for proper and safe handling of the goods. Further, the user releases LTC from all claims arising from the handling or use of the goods. Due to the open construction of the product, it is the user's responsibility to take any and all appropriate precautions with regard to electrostatic discharge. Also be aware that the products herein may not be regulatory compliant or agency certified (FCC, UL, CE, etc.).

No License is granted under any patent right or other intellectual property whatsoever. **LTC assumes no liability for applications assistance, customer product design, software performance, or infringement of patents or any other intellectual property rights of any kind.**

LTC currently services a variety of customers for products around the world, and therefore this transaction **is not exclusive**.

Please read the DEMO BOARD manual prior to handling the product. Persons handling this product must have electronics training and observe good laboratory practice standards. **Common sense is encouraged.**

This notice contains important safety information about temperatures and voltages. For further safety concerns, please contact a LTC application engineer.

Mailing Address:

Linear Technology
1630 McCarthy Blvd.
Milpitas, CA 95035

Copyright © 2004, Linear Technology Corporation



Стандарт Электрон Связь

Мы молодая и активно развивающаяся компания в области поставок электронных компонентов. Мы поставляем электронные компоненты отечественного и импортного производства напрямую от производителей и с крупнейших складов мира.

Благодаря сотрудничеству с мировыми поставщиками мы осуществляем комплексные и плановые поставки широчайшего спектра электронных компонентов.

Собственная эффективная логистика и склад в обеспечивает надежную поставку продукции в точно указанные сроки по всей России.

Мы осуществляем техническую поддержку нашим клиентам и предпродажную проверку качества продукции. На все поставляемые продукты мы предоставляем гарантию .

Осуществляем поставки продукции под контролем ВП МО РФ на предприятия военно-промышленного комплекса России , а также работаем в рамках 275 ФЗ с открытием отдельных счетов в уполномоченном банке. Система менеджмента качества компании соответствует требованиям ГОСТ ISO 9001.

Минимальные сроки поставки, гибкие цены, неограниченный ассортимент и индивидуальный подход к клиентам являются основой для выстраивания долгосрочного и эффективного сотрудничества с предприятиями радиоэлектронной промышленности, предприятиями ВПК и научно-исследовательскими институтами России.

С нами вы становитесь еще успешнее!

Наши контакты:

Телефон: +7 812 627 14 35

Электронная почта: sales@st-electron.ru

Адрес: 198099, Санкт-Петербург,
Промышленная ул, дом № 19, литера Н,
помещение 100-Н Офис 331