

Inductorless, Liquid Lens Driver Demoboard

General Description

The HV892DB1 liquid lens driver demoboard is controlled via an I²C interface, is capable of driving capacitive loads of up to 200pF, and is compatible with 40V_{RMS} to 60V_{RMS} lenses.

A charge pump boost converter integrated on-chip provides the high voltage necessary for driving the lens. No external inductors or diodes are needed. The board requires only two ceramic chip capacitors to complete a lens driver circuit.

An H-bridge output stage provides AC drive to the lens, allowing the use of a single high voltage boost converter while providing alternating polarity to the lens. Controlled rising and falling edges on the drive waveform reduces EMI.

Specifications

Parameter	Value
Supply voltage (V_{IN}):	2.65 – 5.50V
Supply current (I_{IN}):	20mA max operating 500nA max standby
Output voltage (OUT1 – OUT2):	9.8 – 62.6V _{RMS} , adjustable via I ² C
Load (lens) capacitance:	100 – 200pF
I ² C reference voltage (V_{DD}):	1.70 – 2.95V
I ² C clock:	400kHz max
I ² C address (7-bit):	0100011b
Board dimensions:	35.6mm x 26.2mm

Board Layout and Connections

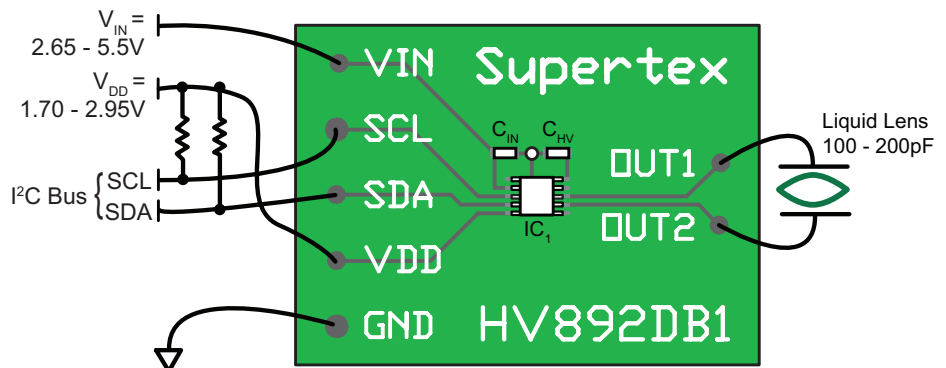

Connections:

VIN

Supply voltage to the HV892. Externally supplied V_{IN} should be between 2.65 and 5.50V.

GND

Circuit common.

VDD

Externally supplied logic reference voltage for the I²C interface. V_{DD} should be between 1.70 and 2.95V.

SCL

I²C clock. Clock frequency should be no greater than 400kHz.

SDA

I²C data.

OUT1 and OUT2

The lens driver output. Connect the lens between these two terminals. Load (lens) capacitance should be between 100 and 200pF, including any stray capacitance.

Note:

The resistors shown in the connection diagram are the normal I²C pull-ups. No additional pull-ups are required.

HV892DB1 Circuit Schematic

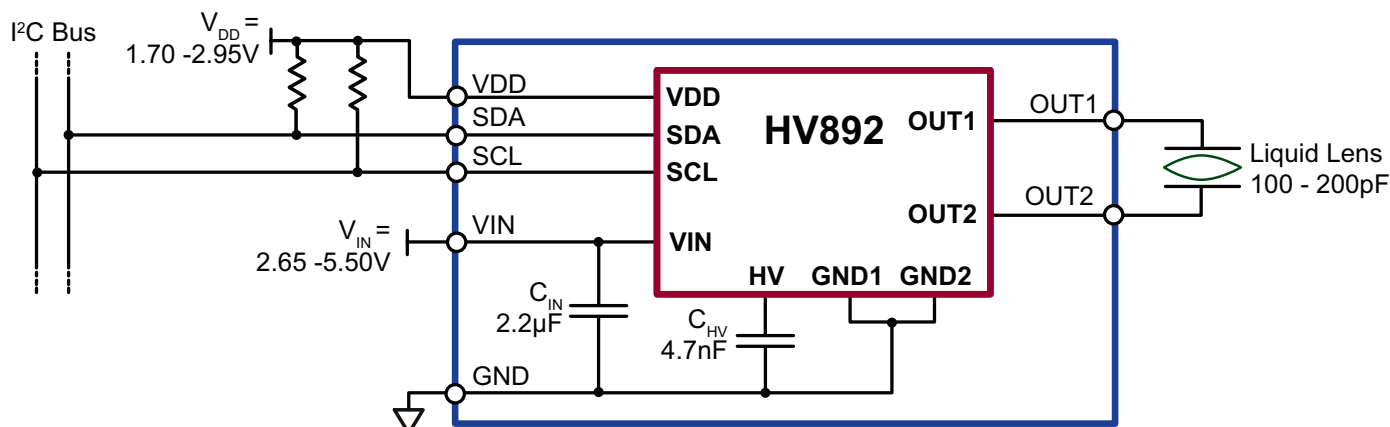

Bill of Materials

Part	Description	Value	Tolerance	Rating	Package	Manufacturer	Part Number
C _{IN}	Ceramic capacitor	2.2µF	20%	6.3V	0603	Any	---
C _{HV}	Ceramic capacitor	4.7nF	10%	100V	0603	Any	---
IC ₁	Lens driver	-	-	-	4x4 DFN	Supertex	HV892K7-G

Operation

A single byte (AMP) written to the HV892 controls the operation of the driver. Setting AMP = 00h causes the HV892 to go into low power standby mode. Setting AMP = 01h to FFh controls output amplitude in 255 monotonic steps.

$$V_{OUT(RMS)} = 9.6V_{RMS} + AMP \cdot 208mV_{RMS}$$

The HV892 is write-only. No readback of the AMP byte is possible.

The HV892's 7-bit address is 0100011b. For large quantity orders, other 7-bit addresses may be obtained.

The resistors shown on the above schematic are the I²C bus' normal pull-ups. No additional pull-ups are required. Externally supplied V_{DD} is the I²C bus' reference voltage.

Externally supplied V_{IN} should be ramped up in less than 2.0ms to ensure the driver starts-up in standby mode. If brought up slower, the driver may not start-up in standby mode, with output amplitude at an indeterminate level. In this case, writing AMP = 00h brings the driver to standby mode. No damage will occur if V_{IN} is brought up slower than 2.0ms.

Light capacitive loads may result in waveform distortion. This is due to the output pins being held at a high-Z state for a portion of the waveform. Without adequate capacitance to hold up the voltage, some droop may be observed when DC-loaded by oscilloscope probes.

To avoid loading down the outputs, use instruments having at least 10MΩ input impedance when taking measurements. While many voltmeters may have a very high input resistance on the DC scale, they frequently have only 1.0MΩ input impedance on the AC scale. Also, be sure to use a voltmeter with true RMS capability.

Supertex inc. does not recommend the use of its products in life support applications, and will not knowingly sell them for use in such applications unless it receives an adequate "product liability indemnification insurance agreement." **Supertex inc.** does not assume responsibility for use of devices described, and limits its liability to the replacement of the devices determined defective due to workmanship. No responsibility is assumed for possible omissions and inaccuracies. Circuitry and specifications are subject to change without notice. For the latest product specifications refer to the **Supertex inc.** (website: <http://www.supertex.com>)



Стандарт Электрон Связь

Мы молодая и активно развивающаяся компания в области поставок электронных компонентов. Мы поставляем электронные компоненты отечественного и импортного производства напрямую от производителей и с крупнейших складов мира.

Благодаря сотрудничеству с мировыми поставщиками мы осуществляем комплексные и плановые поставки широчайшего спектра электронных компонентов.

Собственная эффективная логистика и склад в обеспечивает надежную поставку продукции в точно указанные сроки по всей России.

Мы осуществляем техническую поддержку нашим клиентам и предпродажную проверку качества продукции. На все поставляемые продукты мы предоставляем гарантию .

Осуществляем поставки продукции под контролем ВП МО РФ на предприятия военно-промышленного комплекса России , а также работаем в рамках 275 ФЗ с открытием отдельных счетов в уполномоченном банке. Система менеджмента качества компании соответствует требованиям ГОСТ ISO 9001.

Минимальные сроки поставки, гибкие цены, неограниченный ассортимент и индивидуальный подход к клиентам являются основой для выстраивания долгосрочного и эффективного сотрудничества с предприятиями радиоэлектронной промышленности, предприятиями ВПК и научно-исследовательскими институтами России.

С нами вы становитесь еще успешнее!

Наши контакты:

Телефон: +7 812 627 14 35

Электронная почта: sales@st-electron.ru

Адрес: 198099, Санкт-Петербург,
Промышленная ул, дом № 19, литера Н,
помещение 100-Н Офис 331