

## High voltage fast-switching NPN power transistor

### Features

- High voltage capability
- Low spread of dynamic parameters
- Very high switching speed

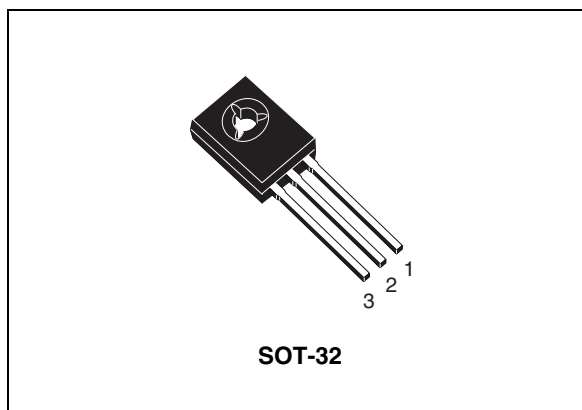
### Applications

- Electronic ballast for fluorescent lighting (CFL)
- SMPS for battery charger

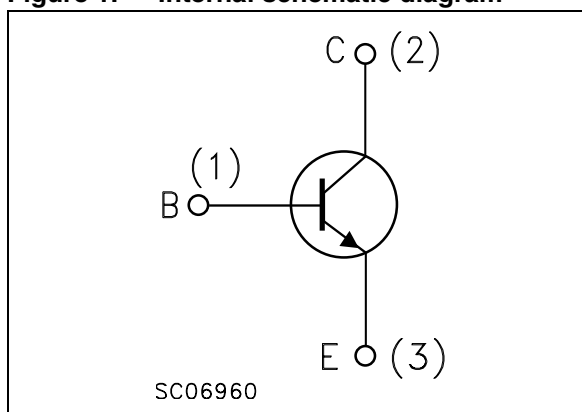
### Description

The device is manufactured using high voltage multi-epitaxial planar technology for high switching speeds and high voltage capability.

It uses a cellular emitter structure with planar edge termination to enhance switching speeds while maintaining the wide RBSOA.



**Figure 1. Internal schematic diagram**



**Table 1. Device summary**

Part number	Marking	Package	Packaging
ST13003-K	13003	SOT-32	Bag

# 1 Electrical ratings

**Table 2. Absolute maximum ratings**

Symbol	Parameter	Value	Unit
$V_{CES}$	Collector-emitter voltage ( $V_{BE} = 0$ )	700	V
$V_{CEO}$	Collector-emitter voltage ( $I_B = 0$ )	400	V
$V_{EBO}$	Emitter-base voltage ( $I_C = 0$ , $I_B = 0.75$ A, $t_P < 10$ $\mu$ s)	$V_{(BR)EBO}$	V
$I_C$	Collector current	1.5	A
$I_{CM}$	Collector peak current ( $t_P < 5$ ms)	3	A
$I_B$	Base current	0.75	A
$I_{BM}$	Base peak current ( $t_P < 5$ ms)	1.5	A
$P_{TOT}$	Total dissipation at $T_C = 25$ °C	40	W
$T_{STG}$	Storage temperature	-55 to 150	°C
$T_J$	Operating junction temperature	-40 to 150	°C

**Table 3. Thermal data**

Symbol	Parameter	Value	Unit
$R_{thJC}$	Thermal resistance junction-case max.	3.1	°C/W

## 2 Electrical characteristics

$T_{\text{case}} = 25\text{ °C}$  unless otherwise specified.

**Table 4. Electrical characteristics**

Symbol	Parameter	Test conditions	Min.	Typ.	Max.	Unit
$I_{\text{CES}}$	Collector cut-off current ( $V_{\text{BE}} = 0$ )	$V_{\text{CE}} = 700\text{ V}$ $V_{\text{CE}} = 700\text{ V}$ $T_{\text{C}} = 125\text{ °C}$			1 5	mA mA
$V_{(\text{BR})\text{EBO}}$	Emitter-Base breakdown voltage ( $I_{\text{C}} = 0$ )	$I_{\text{E}} = 10\text{ mA}$	9		18	V
$V_{\text{CEO(sus)}}^{(1)}$	Collector-emitter sustaining voltage ( $I_{\text{B}} = 0$ )	$I_{\text{C}} = 10\text{ mA}$	400			V
$V_{\text{CE(sat)}}^{(1)}$	Collector-emitter saturation voltage	$I_{\text{C}} = 0.5\text{ A}$ $I_{\text{B}} = 0.1\text{ A}$ $I_{\text{C}} = 1\text{ A}$ $I_{\text{B}} = 0.25\text{ A}$ $I_{\text{C}} = 1.5\text{ A}$ $I_{\text{B}} = 0.5\text{ A}$			0.5 1 1.5	V V V
$V_{\text{BE(sat)}}^{(1)}$	Base-emitter saturation voltage	$I_{\text{C}} = 0.5\text{ A}$ $I_{\text{B}} = 0.1\text{ A}$ $I_{\text{C}} = 1\text{ A}$ $I_{\text{B}} = 0.25\text{ A}$			1 1.2	V V
$h_{\text{FE}}$	DC current gain	$I_{\text{C}} = 0.5\text{ A}$ $V_{\text{CE}} = 2\text{ V}$ $I_{\text{C}} = 1\text{ A}$ $V_{\text{CE}} = 2\text{ V}$	8 5		20 25	
$t_{\text{r}}$ $t_{\text{s}}$ $t_{\text{f}}$	Resistive load Rise time Storage time Fall time	$V_{\text{CC}} = 125\text{ V}$ $I_{\text{C}} = 1\text{ A}$ $I_{\text{B1}} = 0.2\text{ A}$ $I_{\text{B2}} = -0.2\text{ A}$ $T_{\text{p}} = 25\text{ }\mu\text{s}$			1 4 0.7	$\mu\text{s}$ $\mu\text{s}$ $\mu\text{s}$
$t_{\text{s}}$	Inductive load Storage time	$I_{\text{C}} = 1\text{ A}$ $I_{\text{B1}} = 0.2\text{ A}$ $V_{\text{BE}} = -5\text{ V}$ $L = 50\text{ mH}$ $V_{\text{Clamp}} = 300\text{ V}$		0.8		$\mu\text{s}$

1. Pulsed duration = 300  $\mu\text{s}$ , duty cycle  $\leq 1.5\%$

## 2.1 Electrical characteristics (curves)

Figure 2. Safe operating areas

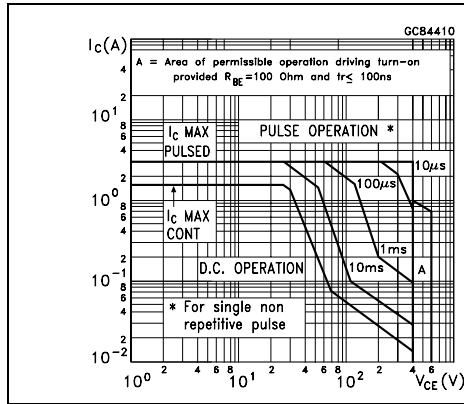


Figure 3. Derating curve

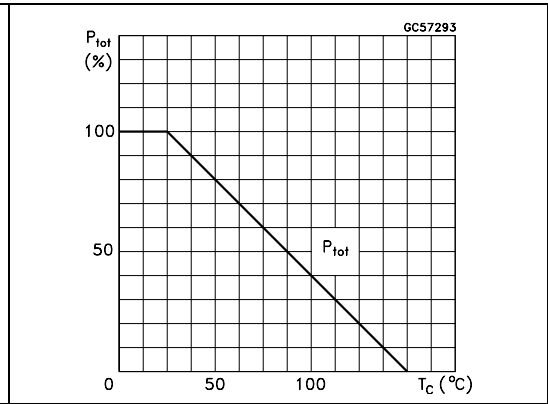


Figure 4. Output characteristics

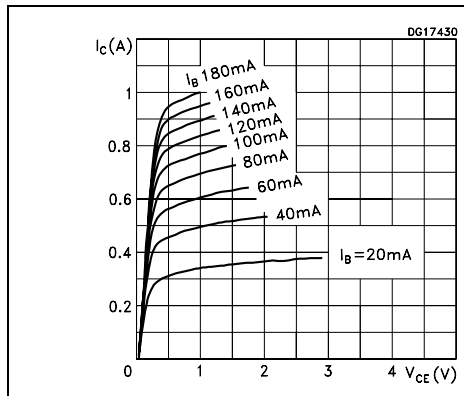


Figure 5. Reverse biased safe operating areas

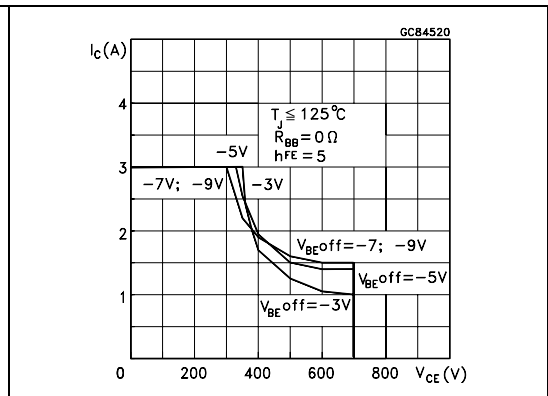


Figure 6. DC current gain ( $V_{CE} = 1 V$ )

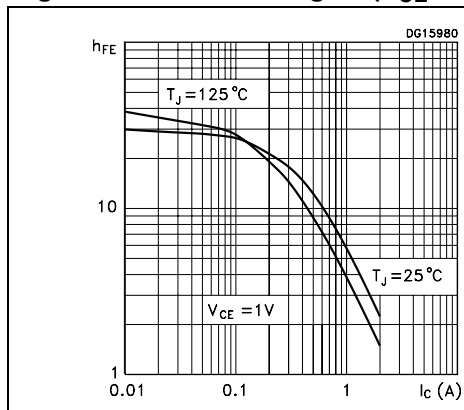
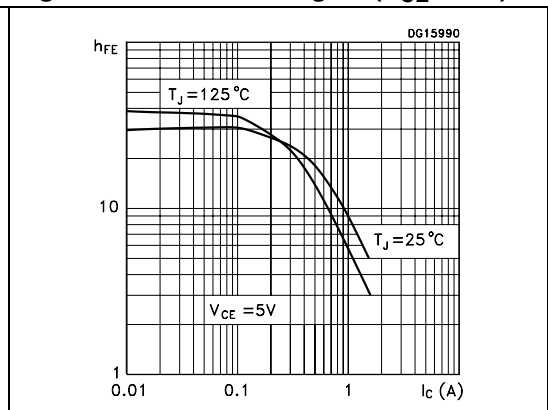
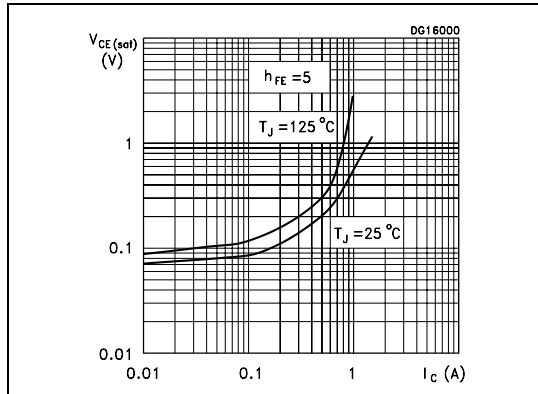


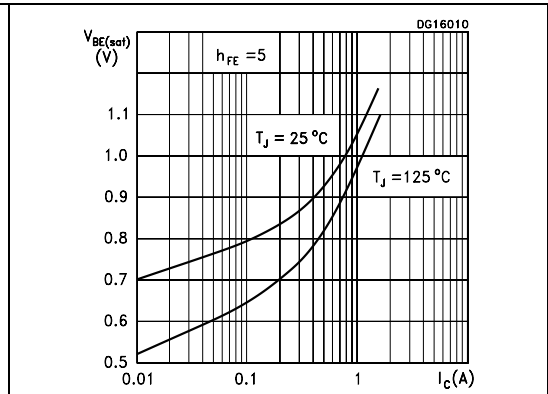
Figure 7. DC current gain ( $V_{CE} = 5 V$ )



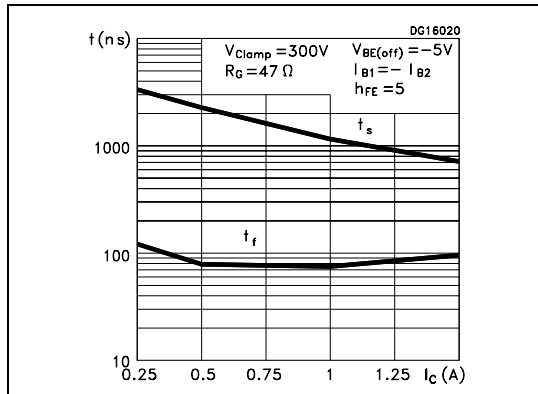
**Figure 8. Collector-emitter saturation voltage**



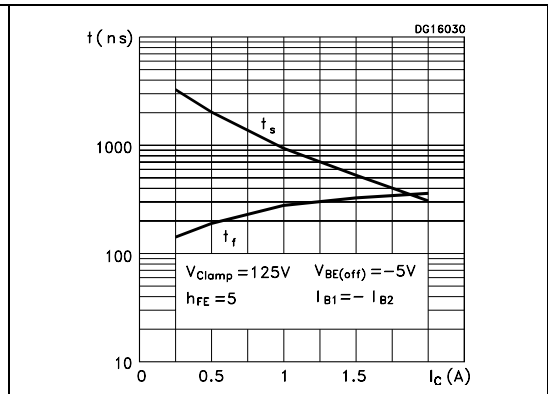
**Figure 9. Base-emitter saturation voltage**



**Figure 10. Inductive load switching time**

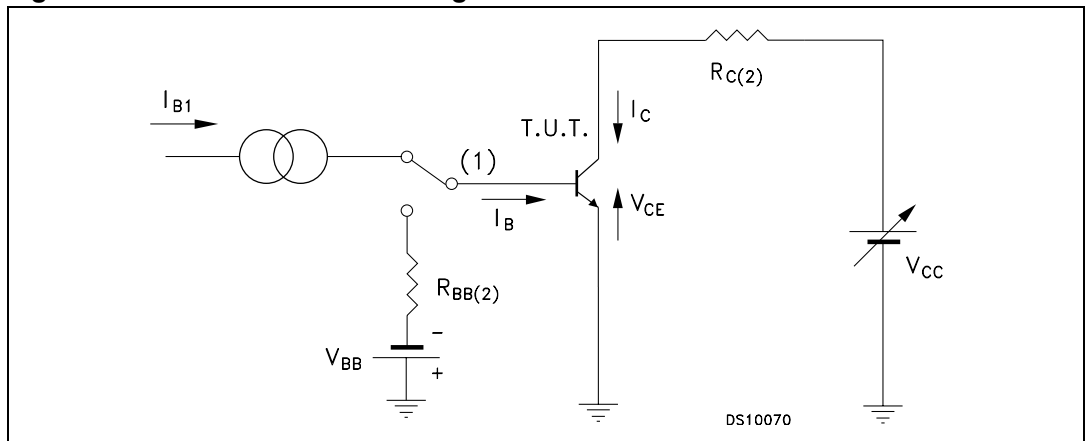


**Figure 11. Resistive load switching time**



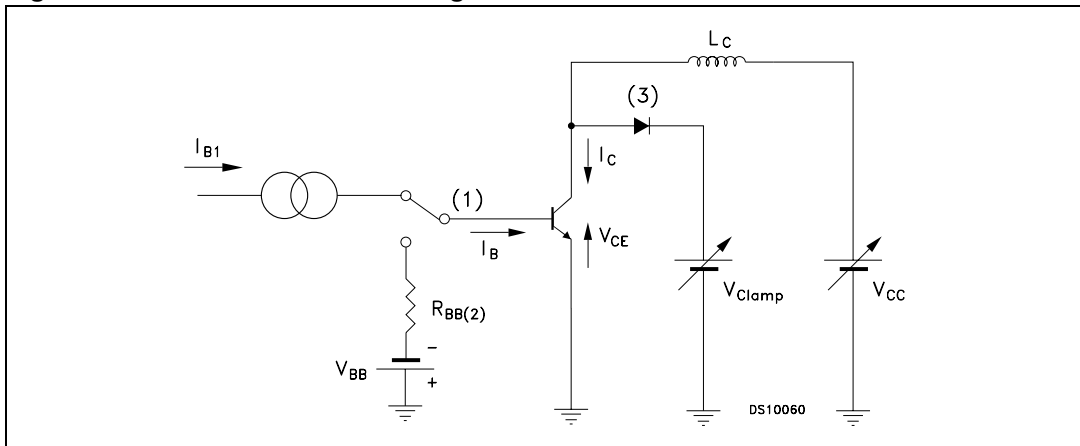
## 2.2 Test circuits

**Figure 12. Resistive load switching test circuit**



1. Fast electronic switch
2. Non-inductive resistor

Figure 13. Inductive load switching test circuit



1. Fast electronic switch
2. Non-inductive resistor
3. Fast recovery rectifier

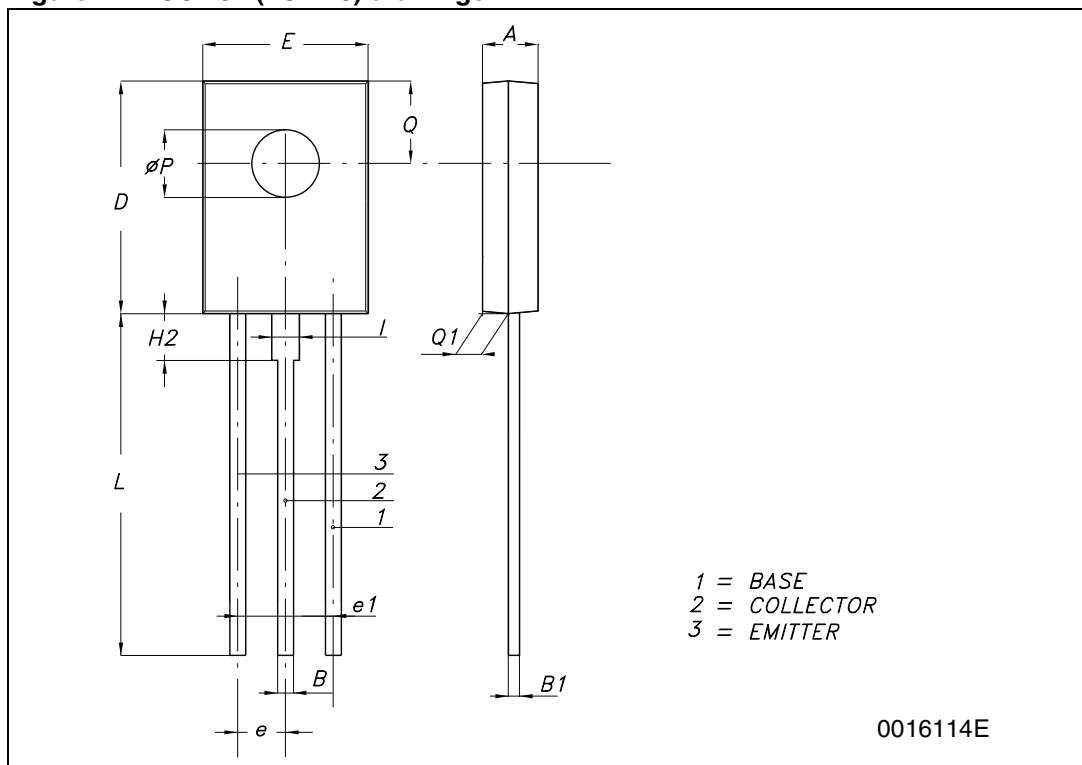
### 3 Package mechanical data

In order to meet environmental requirements, ST offers these devices in different grades of ECOPACK<sup>®</sup> packages, depending on their level of environmental compliance. ECOPACK<sup>®</sup> specifications, grade definitions and product status are available at: [www.st.com](http://www.st.com). ECOPACK<sup>®</sup> is an ST trademark.

Table 5. SOT-32 (TO-126) mechanical data

Dim.	mm.		
	Min.	Typ.	Max.
A	2.4		2.9
B	0.64		0.88
B1	0.39		0.63
D	10.5		11.05
E	7.4		7.8
e	2.04	2.29	2.54
e1	4.07	4.58	5.08
L	15.3		16
P	2.9		3.2
Q		3.8	
Q1	1		1.52
H2		2.15	
I		1.27	

Figure 14. SOT-32 (TO-126) drawings





## 4 Revision history

**Table 6. Document revision history**

Date	Revision	Changes
23-May-2007	1	Initial release.
09-Jul-2008	2	Added <a href="#">Table 1 on page 1</a> .
15-Dec-2009	3	Added <a href="#">Table 3: Thermal data on page 2</a> .
15-Jun-2011	4	Modified: <a href="#">Table 2</a>

**Please Read Carefully:**

Information in this document is provided solely in connection with ST products. STMicroelectronics NV and its subsidiaries ("ST") reserve the right to make changes, corrections, modifications or improvements, to this document, and the products and services described herein at any time, without notice.

All ST products are sold pursuant to ST's terms and conditions of sale.

Purchasers are solely responsible for the choice, selection and use of the ST products and services described herein, and ST assumes no liability whatsoever relating to the choice, selection or use of the ST products and services described herein.

No license, express or implied, by estoppel or otherwise, to any intellectual property rights is granted under this document. If any part of this document refers to any third party products or services it shall not be deemed a license grant by ST for the use of such third party products or services, or any intellectual property contained therein or considered as a warranty covering the use in any manner whatsoever of such third party products or services or any intellectual property contained therein.

**UNLESS OTHERWISE SET FORTH IN ST'S TERMS AND CONDITIONS OF SALE ST DISCLAIMS ANY EXPRESS OR IMPLIED WARRANTY WITH RESPECT TO THE USE AND/OR SALE OF ST PRODUCTS INCLUDING WITHOUT LIMITATION IMPLIED WARRANTIES OF MERCHANTABILITY, FITNESS FOR A PARTICULAR PURPOSE (AND THEIR EQUIVALENTS UNDER THE LAWS OF ANY JURISDICTION), OR INFRINGEMENT OF ANY PATENT, COPYRIGHT OR OTHER INTELLECTUAL PROPERTY RIGHT.**

**UNLESS EXPRESSLY APPROVED IN WRITING BY AN AUTHORIZED ST REPRESENTATIVE, ST PRODUCTS ARE NOT RECOMMENDED, AUTHORIZED OR WARRANTED FOR USE IN MILITARY, AIR CRAFT, SPACE, LIFE SAVING, OR LIFE SUSTAINING APPLICATIONS, NOR IN PRODUCTS OR SYSTEMS WHERE FAILURE OR MALFUNCTION MAY RESULT IN PERSONAL INJURY, DEATH, OR SEVERE PROPERTY OR ENVIRONMENTAL DAMAGE. ST PRODUCTS WHICH ARE NOT SPECIFIED AS "AUTOMOTIVE GRADE" MAY ONLY BE USED IN AUTOMOTIVE APPLICATIONS AT USER'S OWN RISK.**

Resale of ST products with provisions different from the statements and/or technical features set forth in this document shall immediately void any warranty granted by ST for the ST product or service described herein and shall not create or extend in any manner whatsoever, any liability of ST.

ST and the ST logo are trademarks or registered trademarks of ST in various countries.

Information in this document supersedes and replaces all information previously supplied.

The ST logo is a registered trademark of STMicroelectronics. All other names are the property of their respective owners.

© 2011 STMicroelectronics - All rights reserved

STMicroelectronics group of companies

Australia - Belgium - Brazil - Canada - China - Czech Republic - Finland - France - Germany - Hong Kong - India - Israel - Italy - Japan - Malaysia - Malta - Morocco - Philippines - Singapore - Spain - Sweden - Switzerland - United Kingdom - United States of America

[www.st.com](http://www.st.com)



## Стандарт Электрон Связь

Мы молодая и активно развивающаяся компания в области поставок электронных компонентов. Мы поставляем электронные компоненты отечественного и импортного производства напрямую от производителей и с крупнейших складов мира.

Благодаря сотрудничеству с мировыми поставщиками мы осуществляем комплексные и плановые поставки широчайшего спектра электронных компонентов.

Собственная эффективная логистика и склад в обеспечивает надежную поставку продукции в точно указанные сроки по всей России.

Мы осуществляем техническую поддержку нашим клиентам и предпродажную проверку качества продукции. На все поставляемые продукты мы предоставляем гарантию .

Осуществляем поставки продукции под контролем ВП МО РФ на предприятия военно-промышленного комплекса России , а также работаем в рамках 275 ФЗ с открытием отдельных счетов в уполномоченном банке. Система менеджмента качества компании соответствует требованиям ГОСТ ISO 9001.

Минимальные сроки поставки, гибкие цены, неограниченный ассортимент и индивидуальный подход к клиентам являются основой для выстраивания долгосрочного и эффективного сотрудничества с предприятиями радиоэлектронной промышленности, предприятиями ВПК и научно-исследовательскими институтами России.

С нами вы становитесь еще успешнее!

### Наши контакты:

**Телефон:** +7 812 627 14 35

**Электронная почта:** [sales@st-electron.ru](mailto:sales@st-electron.ru)

**Адрес:** 198099, Санкт-Петербург,  
Промышленная ул, дом № 19, литера Н,  
помещение 100-Н Офис 331