

# IFX1050GVIO

High Speed CAN-Transceiver

## Data Sheet

Rev. 1.0, 2011-04-08

Standard Power

## Table of Contents

1	<b>Overview</b> .....	3
2	<b>Pin Configuration</b> .....	4
3	<b>Block Diagram</b> .....	5
4	<b>Electrical Characteristics</b> .....	6
4.1	Operating Range .....	6
5	<b>Diagrams</b> .....	11
6	<b>Application Information</b> .....	13
7	<b>Package Outlines</b> .....	17
8	<b>Revision History</b> .....	18



## 1 Overview

### Features

- CAN data transmission rate up to 1 Mbaud
- Stand-by Mode
- Suitable for 12 V and 24 V applications
- Excellent EMC performance (very high immunity and very low emission)
- Bus pins are short circuit proof to ground and battery voltage
- Versions for 5V and 3.3V microcontrollers
- Overtemperature protection
- Green Product (RoHS compliant)

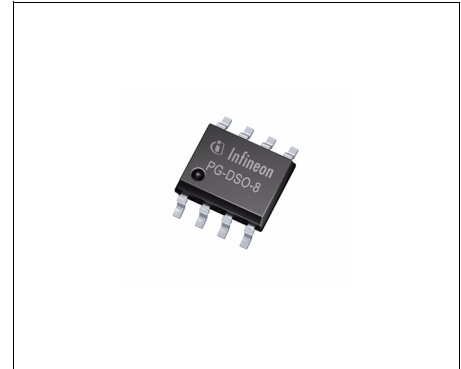

PG-DSO-8

### Description

The HS CAN-transceiver IFX1050GVIO is optimized for high speed differential mode data transmission in industrial applications and is compatible to ISO/DIS 11898. It works as an interface between the CAN protocol controller and the physical differential bus in both, 12 V and 24 V systems.

The IFX1050GVIO is designed to withstand the conditions of industrial applications and provides excellent EMC performance.

### IFX1050GVIO

3.3 V logic I/O version (logic I/O voltage adaptive to  $V_{33}$  pin within the range 3.3 V to 5 V):

RxD, TxD, INH. One control pin (INH) and two operation modes: Normal Mode and Standby Mode.

Type	Package	Marking
IFX1050GVIO	PG-DSO-8	1050IO

## 2 Pin Configuration

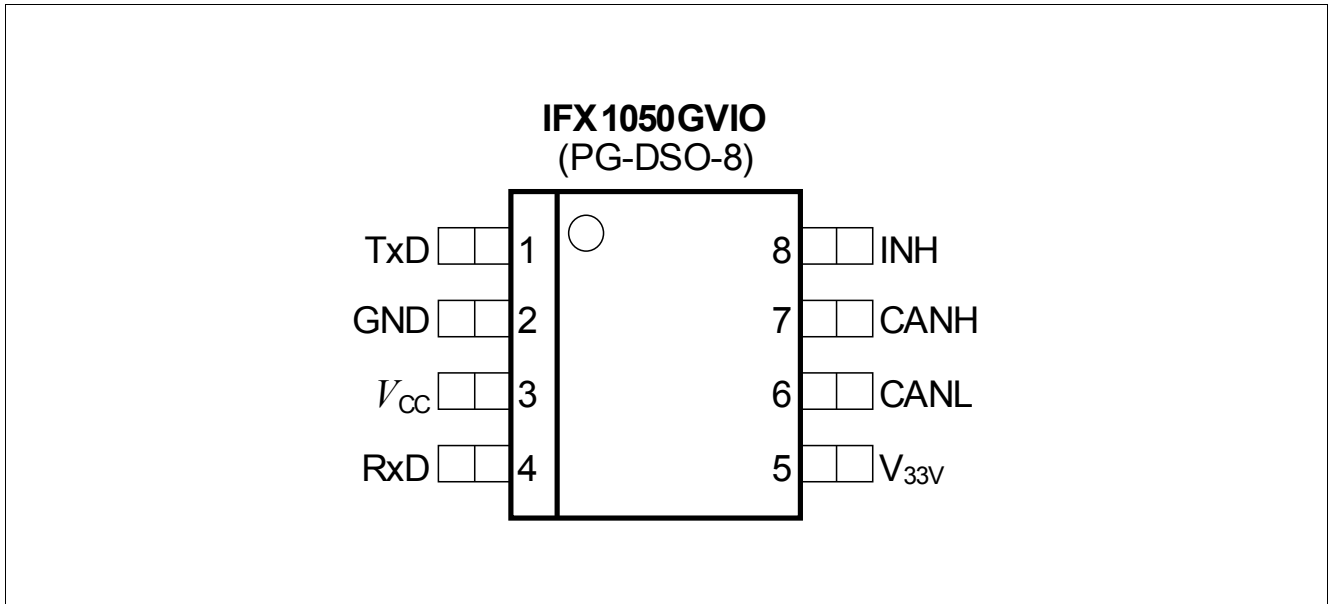

Figure 1 Pin Configuration IFX1050GVIO (top view)

Table 1 Pin Definitions and Functions IFX1050GVIO

Pin No.	Symbol	Function
1	TxD	<b>CAN transmit data input</b> ; 20 k $\Omega$ pull-up, LOW in dominant state
2	GND	<b>Ground</b>
3	$V_{CC}$	<b>5 V Supply input</b>
4	RxD	<b>CAN receive data output</b> ; LOW in dominant state, integrated pull-up
5	$V_{33V}$	<b>Logic supply input</b> ; <b>3.3V or 5V</b> microcontroller logic supply can be connected here! The digital I/Os of the IFX1050GVIO adopt to the connected microcontroller logic supply a $V_{33V}$
6	CANL	<b>Low line I/O</b> ; LOW in dominant state
7	CANH	<b>High line I/O</b> ; HIGH in dominant state
8	INH	<b>Inhibit Input</b> ; control input, 20 k $\Omega$ pull, set LOW for normal mode

### 3 Block Diagram

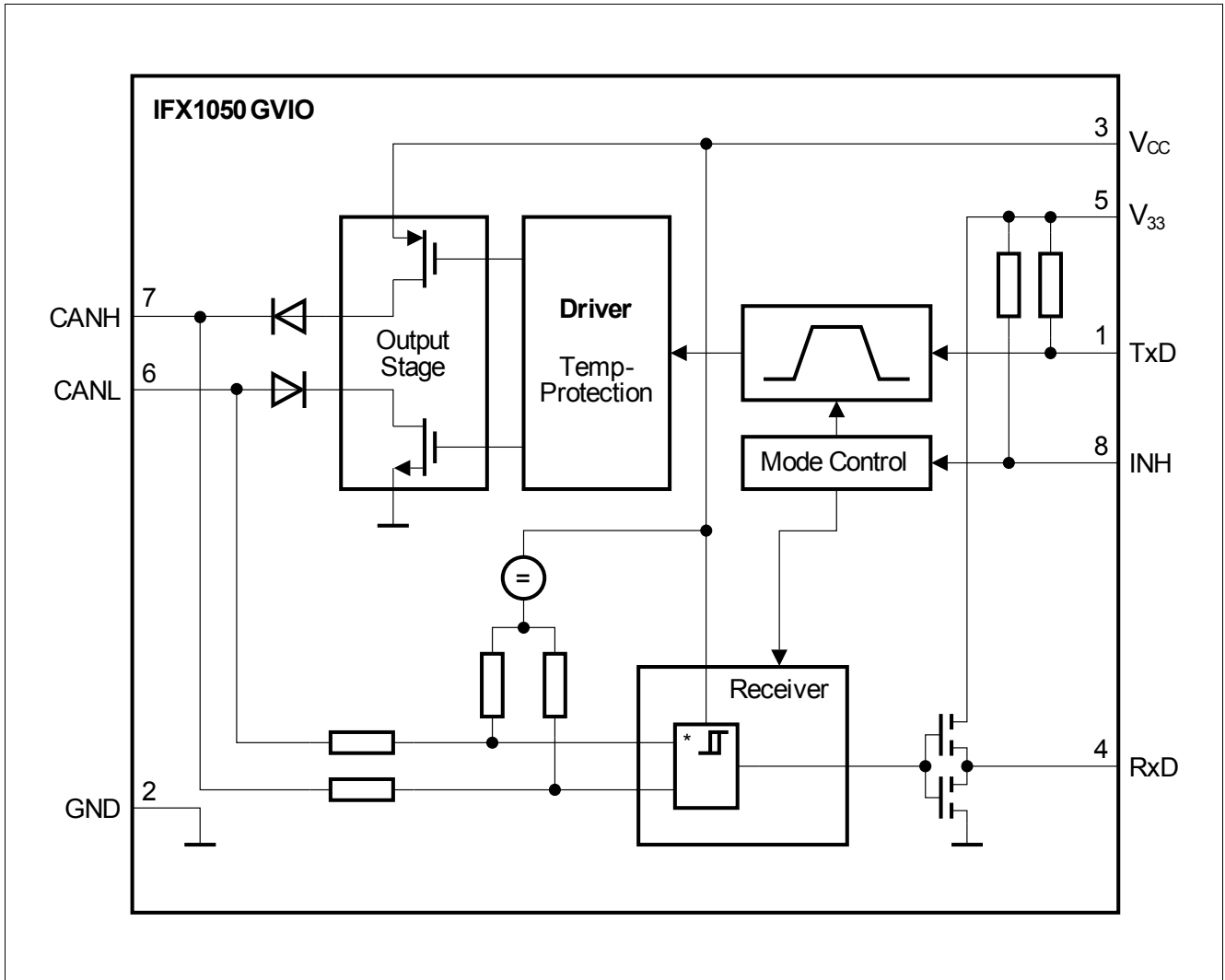

Figure 2 Block Diagram IFX1050GVIO

## 4 Electrical Characteristics

**Table 2 Absolute Maximum Ratings**

Parameter	Symbol	Limit Values		Unit	Remarks
		Min.	Max.		
<b>Voltages</b>					
Supply voltage	$V_{CC}$	-0.3	6.5	V	–
3.3V supply	$V_{33V}$	-0.3	6.5	V	–
CAN input voltage (CANH, CANL)	$V_{CANH/L}$	-40	40	V	–
Logic voltages at INH, RM, TxD, RxD	$V_I$	-0.3	$V_{CC}$	V	$0\text{ V} < V_{CC} < 5.5\text{ V}$
Electrostatic discharge voltage at CANH, CANL	$V_{ESD}$	-6	6	kV	human body model (100 pF via 1.5 k $\Omega$ )
Electrostatic discharge voltage	$V_{ESD}$	-2	2	kV	human body model (100 pF via 1.5 k $\Omega$ )
<b>Temperatures</b>					
Junction temperature	$T_j$	-40	150	$^{\circ}\text{C}$	–

Note: Maximum ratings are absolute ratings; exceeding any one of these values may cause irreversible damage to the integrated circuit.

### 4.1 Operating Range

**Table 3 Operating Range**

Parameter	Symbol	Limit Values		Unit	Remarks
		Min.	Max.		
Supply voltage	$V_{CC}$	4.5	5.5	V	–
3.3V supply voltage	$V_{33V}$	3.0	5.5	V	–
Junction temperature	$T_j$	-40	125	$^{\circ}\text{C}$	–
<b>Thermal Resistances</b>					
Junction ambient	$R_{thj-a}$	–	185	K/W	–
<b>Thermal Shutdown (junction temperature)</b>					
Thermal shutdown temperature	$T_{jsD}$	160	200	$^{\circ}\text{C}$	10 $^{\circ}\text{C}$ hysteresis

**Electrical Characteristics**
**Table 4 Electrical Characteristics**

4.5 V <  $V_{CC}$  < 5.5 V; 3.0 V <  $V_{33V}$  < 5.5 V  $R_L = 60 \Omega$ ;  $V_{INH} < V_{INH,ON}$ ;  $-40 \text{ }^\circ\text{C} < T_j < 125 \text{ }^\circ\text{C}$ ; all voltages with respect to ground; positive current flowing into pin; unless otherwise specified.

Parameter	Symbol	Limit Values			Unit	Remarks
		Min.	Typ.	Max.		
<b>Current Consumption</b>						
Current consumption	$I_{CC+33V}$	–	6	10	mA	recessive state; $V_{TxD} = V_{33V}$
Current consumption	$I_{CC+33V}$	–	45	70	mA	dominant state; $V_{TxD} = 0 \text{ V}$
Current consumption	$I_{33V}$	–	–	2	mA	–
Current consumption	$I_{CC+33V, stb}$	–	1	10	$\mu\text{A}$	stand-by mode; TxD = high
<b>Receiver Output RxD</b>						
HIGH level output current	$I_{RD,H}$	–	-2	-1	mA	$V_{RD} = 0.8 \times V_{33V}$ , $V_{diff} < 0.4 \text{ V}^1)$
LOW level output current	$I_{RD,L}$	1	2	–	mA	$V_{RD} = 0.2 \times V_{33V}$ , $V_{diff} > 1 \text{ V}^1)$
<b>Transmission Input TxD</b>						
HIGH level input voltage threshold	$V_{TD,H}$	–	$0.55 \times V_{33V}$	$0.7 \times V_{33V}$	V	recessive state
LOW level input voltage threshold	$V_{TD,L}$	$0.3 \times V_{33V}$	$0.45 \times V_{33V}$	–	V	dominant state
TxD pull-up resistance	$R_{TD}$	10	25	50	k $\Omega$	–
<b>Inhibit Input (pin INH)</b>						
HIGH level input voltage threshold	$V_{INH,H}$	–	$0.55 \times V_{33V}$	$0.7 \times V_{33V}$	V	stand-by mode;
LOW level input voltage threshold	$V_{INH,L}$	$0.3 \times V_{33V}$	$0.45 \times V_{33V}$	–	V	normal mode
INH pull-up resistance	$R_{INH}$	10	25	50	k $\Omega$	–

**Electrical Characteristics**
**Table 4 Electrical Characteristics (cont'd)**

4.5 V <  $V_{CC}$  < 5.5 V; 3.0 V <  $V_{33V}$  < 5.5 V  $R_L = 60 \Omega$ ;  $V_{INH} < V_{INH,ON}$ ; -40 °C <  $T_j$  < 125 °C; all voltages with respect to ground; positive current flowing into pin; unless otherwise specified.

Parameter	Symbol	Limit Values			Unit	Remarks
		Min.	Typ.	Max.		
<b>Bus Receiver</b>						
Differential receiver threshold voltage, recessive to dominant edge	$V_{diff,d}$	–	0.75	0.90	V	-20 V < ( $V_{CANH}$ , $V_{CANL}$ ) < 25 V $V_{diff} = V_{CANH} - V_{CANL}$
Differential receiver threshold voltage dominant to recessive edge	$V_{diff,r}$	0.50	0.60	–	V	-20 V < ( $V_{CANH}$ , $V_{CANL}$ ) < 25 V $V_{diff} = V_{CANH} - V_{CANL}$
Common Mode Range	CMR	-20	–	25	V	$V_{CC} = 5 V$
Differential receiver hysteresis	$V_{diff,hys}$	–	150	–	mV	–
CANH, CANL input resistance	$R_i$	10	20	30	k $\Omega$	recessive state
Differential input resistance	$R_{diff}$	20	40	60	k $\Omega$	recessive state



**Electrical Characteristics**
**Table 4 Electrical Characteristics (cont'd)**

4.5 V <  $V_{CC}$  < 5.5 V; 3.0 V <  $V_{33V}$  < 5.5 V  $R_L = 60 \Omega$ ;  $V_{INH} < V_{INH,ON}$ ; -40 °C <  $T_j$  < 125 °C; all voltages with respect to ground; positive current flowing into pin; unless otherwise specified.

Parameter	Symbol	Limit Values			Unit	Remarks
		Min.	Typ.	Max.		
<b>Bus Transmitter</b>						
CANL/CANH recessive output voltage	$V_{CANL/H}$	$0.4 \times V_{CC}$	–	$0.6 \times V_{CC}$	V	$V_{TxD} = V_{33V}$
CANH, CANL recessive output voltage difference $V_{diff} = V_{CANH} - V_{CANL}$ , no load <sup>2)</sup>	$V_{diff}$	-1	–	0.05	V	$V_{TxD} = V_{33V}$
CANL dominant output voltage	$V_{CANL}$	–	–	2.0	V	$V_{TxD} = 0 V$ ; $V_{CC} = 5 V$
CANH dominant output voltage	$V_{CANH}$	2.8	–	–	V	$V_{TxD} = 0 V$ ; $V_{CC} = 5 V$
CANH, CANL dominant output voltage difference $V_{diff} = V_{CANH} - V_{CANL}$	$V_{diff}$	1.5	–	3.0	V	$V_{TxD} = 0 V$ ; $V_{CC} = 5 V$
CANL short circuit current	$I_{CANLsc}$	50	120	200	mA	$V_{CANLshort} = 18 V$
		–	150	–	mA	$V_{CANLshort} = 36 V$
CANH short circuit current	$I_{CANHsc}$	-200	-120	-50	mA	$V_{CANHshort} = 0 V$
CANH short circuit current	$I_{CANHsc}$	–	-120	–	mA	$V_{CANHshort} = -5 V$
Output current	$I_{CANH/L,ik}$	-50	-300	-400	$\mu A$	$V_{CC} = 0 V$ , $V_{CANH} = V_{CANL} = -7 V$
		-50	-100	-150	$\mu A$	$V_{CC} = 0 V$ , $V_{CANH} = V_{CANL} = -2 V$
Output current	$I_{CANH/L,ik}$	50	280	400	$\mu A$	$V_{CC} = 0 V$ , $V_{CANH} = V_{CANL} = 7 V$
		50	100	150	$\mu A$	$V_{CC} = 0 V$ , $V_{CANH} = V_{CANL} = 2 V$

## Electrical Characteristics

**Table 4 Electrical Characteristics (cont'd)**

4.5 V <  $V_{CC}$  < 5.5 V; 3.0 V <  $V_{33V}$  < 5.5 V  $R_L = 60 \Omega$ ;  $V_{INH} < V_{INH,ON}$ ;  $-40 \text{ }^\circ\text{C} < T_j < 125 \text{ }^\circ\text{C}$ ; all voltages with respect to ground; positive current flowing into pin; unless otherwise specified.

Parameter	Symbol	Limit Values			Unit	Remarks
		Min.	Typ.	Max.		
<b>Dynamic CAN-Transceiver Characteristics</b>						
Propagation delay TxD-to-RxD LOW (recessive to dominant)	$t_{d(L),TR}$	–	150	280	ns	$C_L = 47 \text{ pF}$ ; $R_L = 60 \Omega$ ; $V_{CC} = 5 \text{ V}$ ; $C_{RxD} = 20 \text{ pF}$
Propagation delay TxD-to-RxD HIGH (dominant to recessive)	$t_{d(H),TR}$	–	150	280	ns	$C_L = 47 \text{ pF}$ ; $R_L = 60 \Omega$ ; $V_{CC} = 5 \text{ V}$ ; $C_{RxD} = 20 \text{ pF}$
Propagation delay TxD LOW to bus dominant	$t_{d(L),T}$	–	100	140	ns	$C_L = 47 \text{ pF}$ ; $R_L = 60 \Omega$ ; $V_{CC} = 5 \text{ V}$
Propagation delay TxD HIGH to bus recessive	$t_{d(H),T}$	–	100	140	ns	$C_L = 47 \text{ pF}$ ; $R_L = 60 \Omega$ ; $V_{CC} = 5 \text{ V}$
Propagation delay bus dominant to RxD LOW	$t_{d(L),R}$	–	50	140	ns	$C_L = 47 \text{ pF}$ ; $R_L = 60 \Omega$ ; $V_{CC} = 5 \text{ V}$ ; $C_{RxD} = 20 \text{ pF}$
Propagation delay bus recessive to RxD HIGH	$t_{d(H),R}$	–	50	140	ns	$C_L = 47 \text{ pF}$ ; $R_L = 60 \Omega$ ; $V_{CC} = 5 \text{ V}$ ; $C_{RxD} = 20 \text{ pF}$

1)  $V_{diff} = V_{CANH} - V_{CANL}$

2) Deviation from ISO/DIS 11898

5 Diagrams

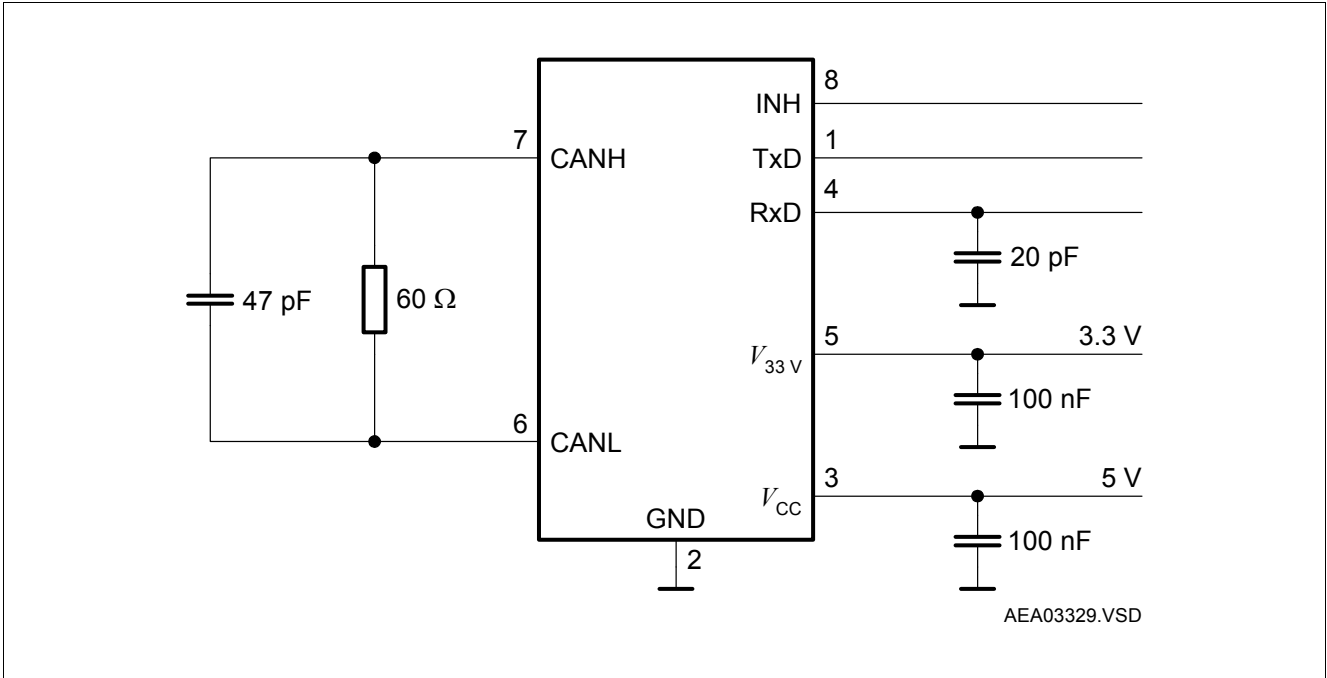

Figure 3 Test Circuit for Dynamic Characteristics

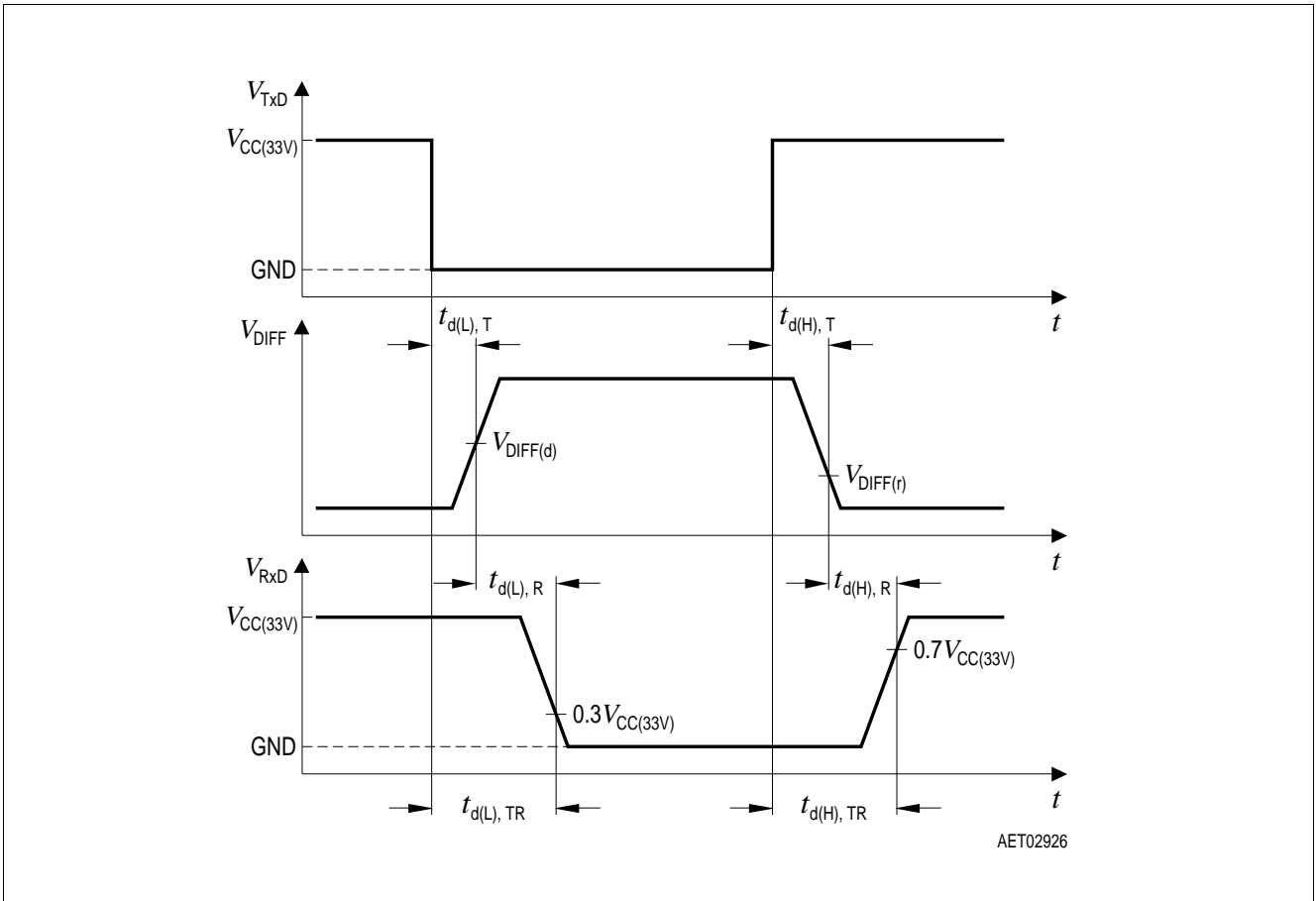
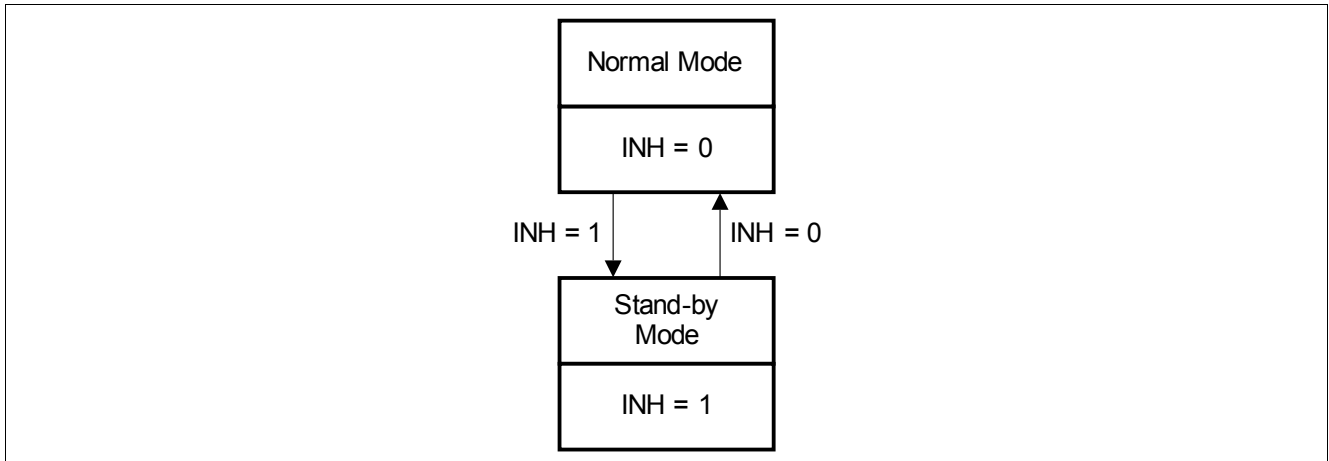

Figure 4 Timing Diagrams for Dynamic Characteristics

## 6 Application Information



**Figure 5 Mode State Diagram**

The IFX1050GVIO offers two different operation modes (see [Figure 5](#)), controlled by the INH pin.

In the normal mode the device is able to receive and to transmit data from the TxD pin to the CAN bus. The stand-by mode is a low power mode that disables both, the receiver as well as the transmitter.

When the stand-by mode is not used the INH pin has to be connected to ground level in order to switch the IFX1050GVIO into normal mode.

### Application Information for the 3.3 V Version

The IFX1050GVIO can be used for both; 3.3 V and 5 V microcontroller logic supply, as shown in [Figure 6](#). Don't apply any external resistors between the power supply and this pin. This may cause a voltage drop and reduce the available voltage at this pin.

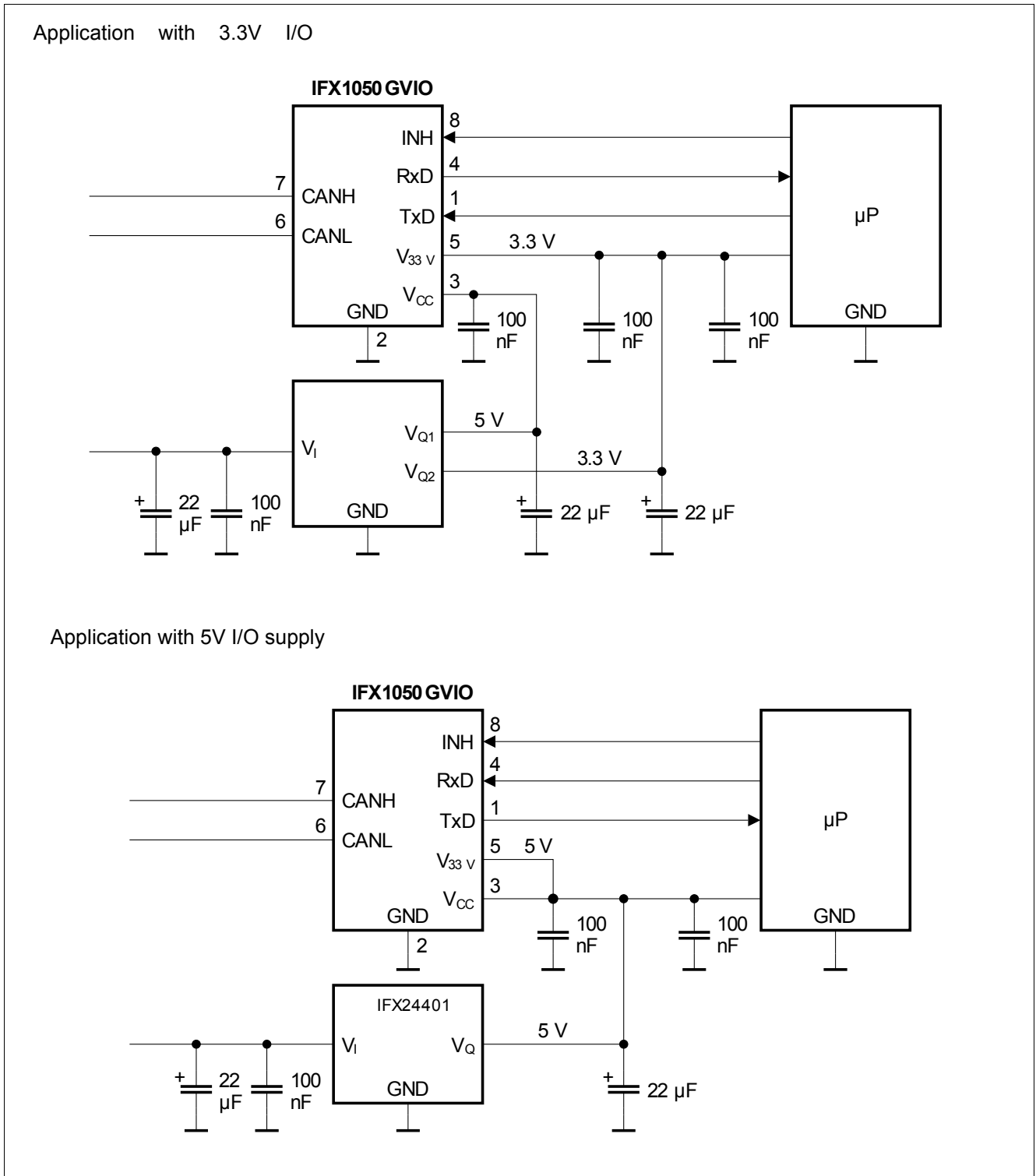

Figure 6 Application Circuit IFX1050GVIO used for 3.3 and 5V Logic

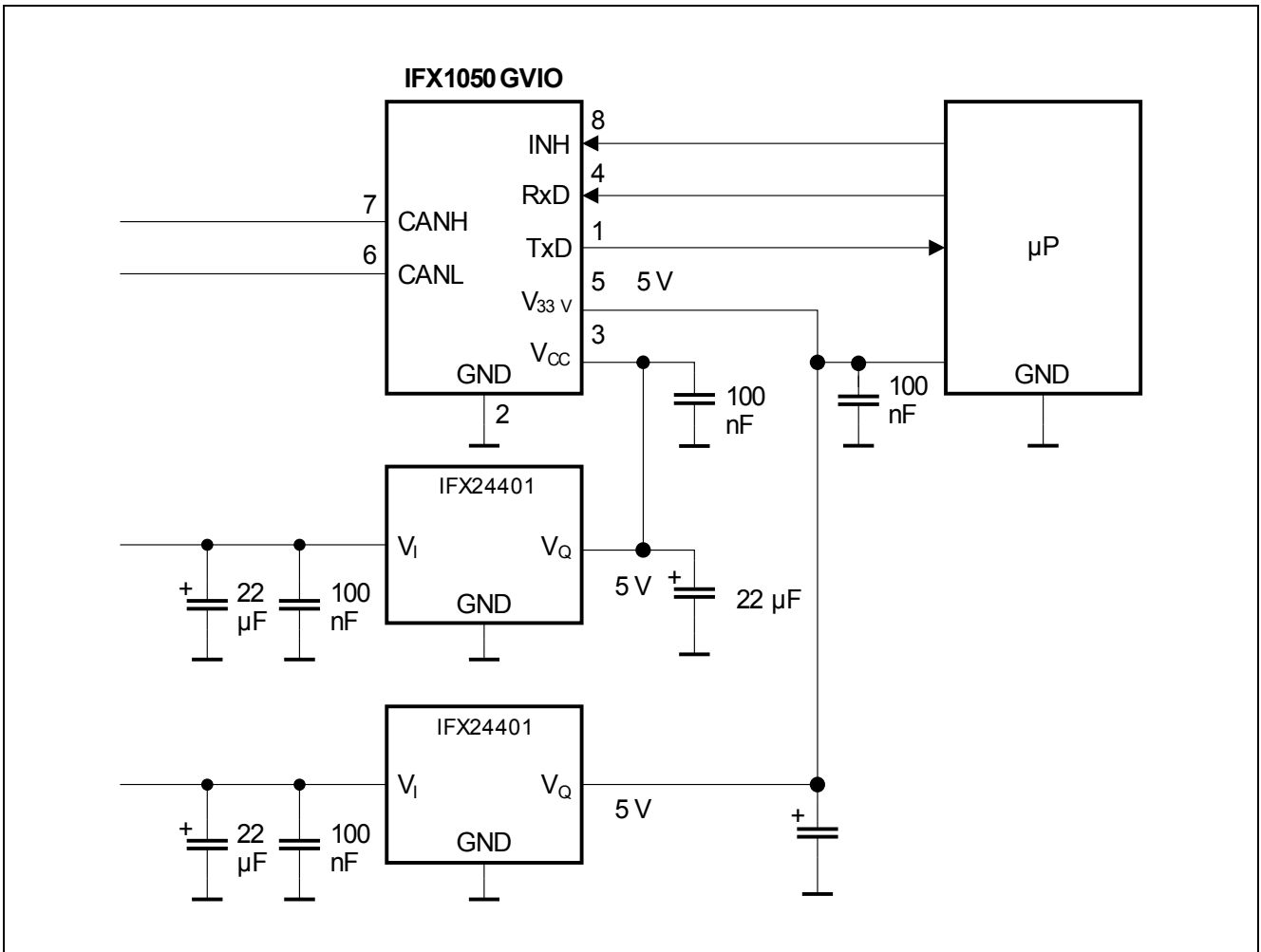

Figure 7 Figure 4 (cont.) Application Circuit IFX1050GVIO used for 3.3 and 5V Logic

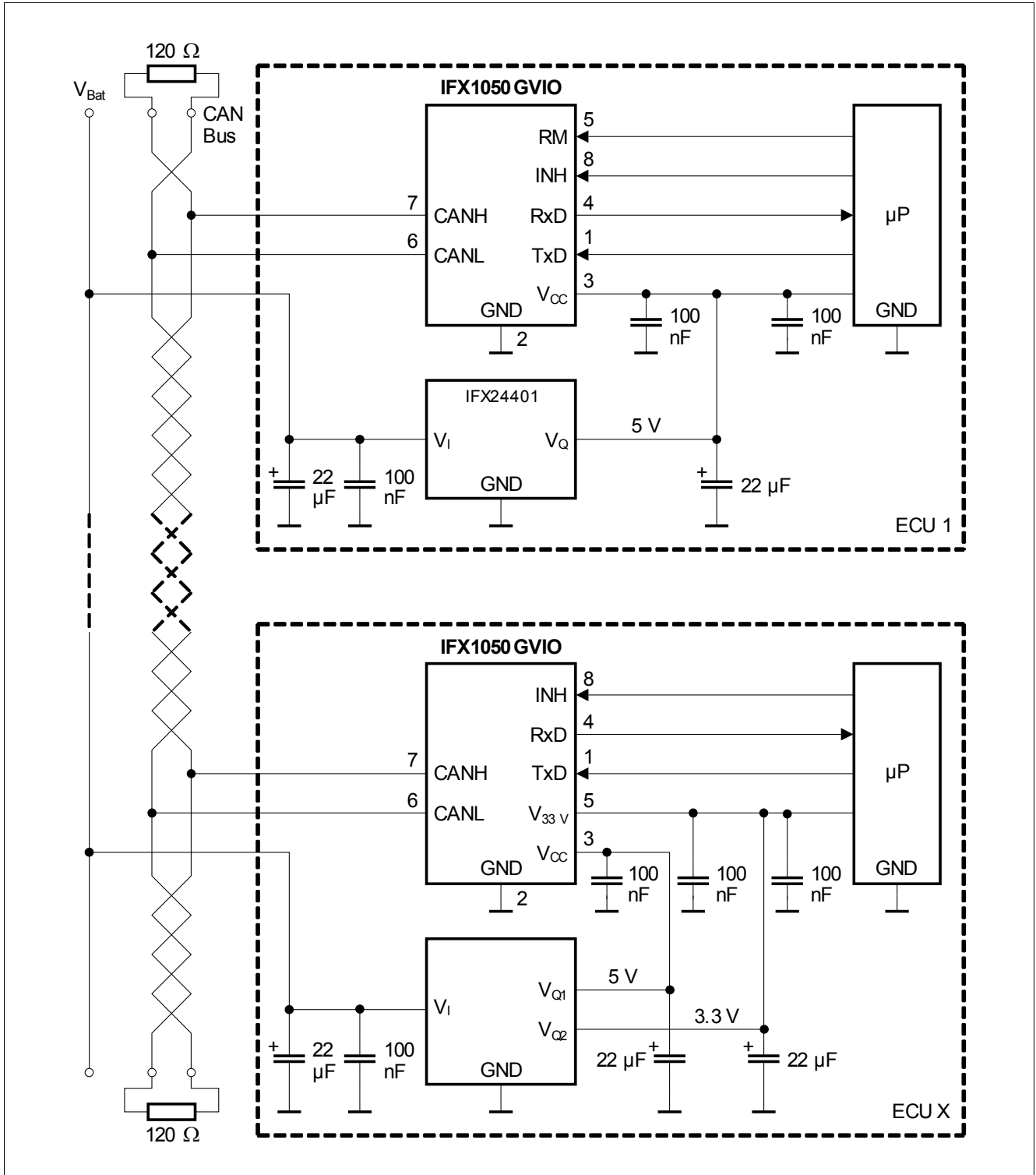
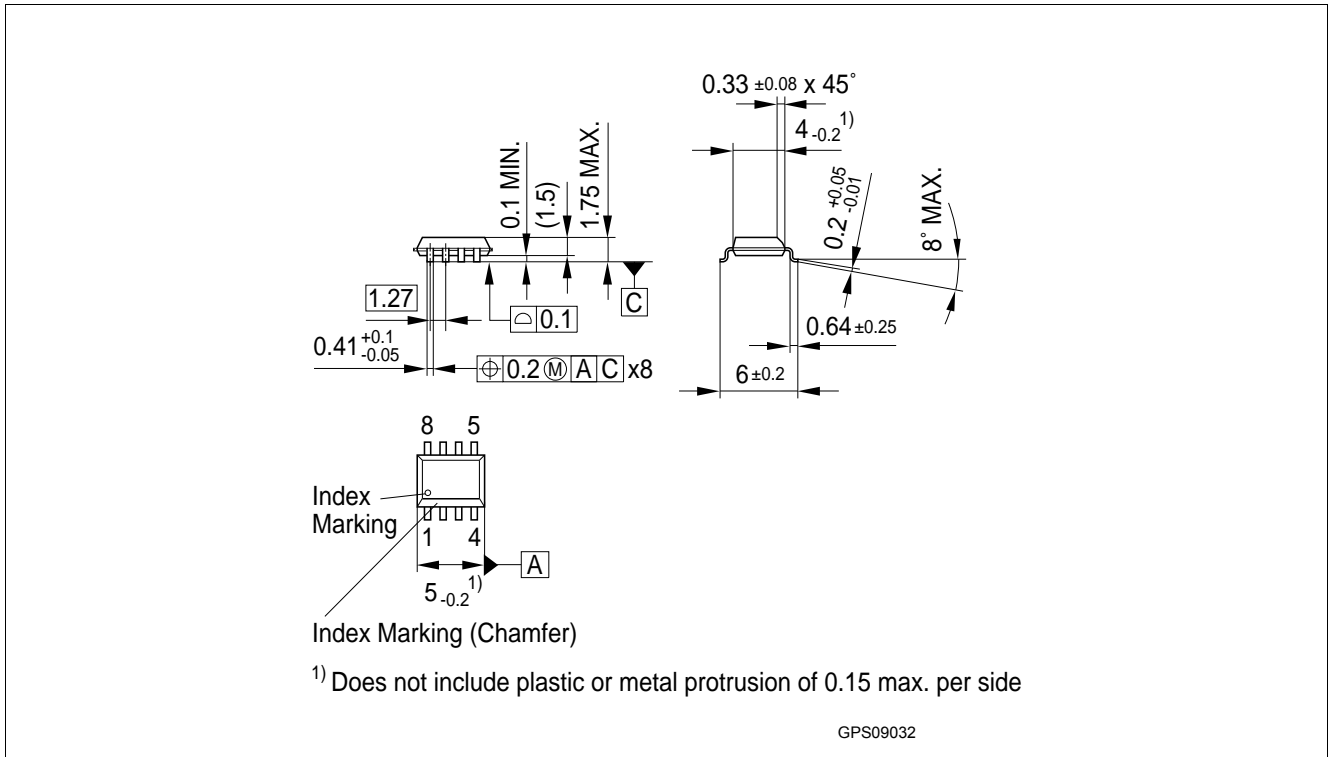

Figure 8 Application Circuit IFX1050GVIO

Applications with separate 5V power supplies,  
for applications with switchable transceiver



## 7 Package Outlines



**Figure 9** PG-DSO-8 (Plastic Dual Small Outline), lead free version

### Green Product (RoHS compliant)

To meet the world-wide customer requirements for environmentally friendly products and to be compliant with government regulations the device is available as a green product. Green products are RoHS-Compliant (i.e Pb-free finish on leads and suitable for Pb-free soldering according to IPC/JEDEC J-STD-020).

## 8 Revision History

Revision	Date	Changes
1.0	2011-04-08	Release Datasheet

**Edition 2011-04-08**

**Published by  
Infineon Technologies AG  
81726 Munich, Germany**

**© 2011 Infineon Technologies AG  
All Rights Reserved.**

### **Legal Disclaimer**

The information given in this document shall in no event be regarded as a guarantee of conditions or characteristics. With respect to any examples or hints given herein, any typical values stated herein and/or any information regarding the application of the device, Infineon Technologies hereby disclaims any and all warranties and liabilities of any kind, including without limitation, warranties of non-infringement of intellectual property rights of any third party.

### **Information**

For further information on technology, delivery terms and conditions and prices, please contact the nearest Infineon Technologies Office ([www.infineon.com](http://www.infineon.com)).

### **Warnings**

Due to technical requirements, components may contain dangerous substances. For information on the types in question, please contact the nearest Infineon Technologies Office.

The Infineon Technologies component described in this Data Sheet may be used in life-support devices or systems and/or automotive, aviation and aerospace applications or systems only with the express written approval of Infineon Technologies, if a failure of such components can reasonably be expected to cause the failure of that life-support automotive, aviation and aerospace device or system or to affect the safety or effectiveness of that device or system. Life support devices or systems are intended to be implanted in the human body or to support and/or maintain and sustain and/or protect human life. If they fail, it is reasonable to assume that the health of the user or other persons may be endangered.



## Стандарт Электрон Связь

Мы молодая и активно развивающаяся компания в области поставок электронных компонентов. Мы поставляем электронные компоненты отечественного и импортного производства напрямую от производителей и с крупнейших складов мира.

Благодаря сотрудничеству с мировыми поставщиками мы осуществляем комплексные и плановые поставки широчайшего спектра электронных компонентов.

Собственная эффективная логистика и склад в обеспечивает надежную поставку продукции в точно указанные сроки по всей России.

Мы осуществляем техническую поддержку нашим клиентам и предпродажную проверку качества продукции. На все поставляемые продукты мы предоставляем гарантию .

Осуществляем поставки продукции под контролем ВП МО РФ на предприятия военно-промышленного комплекса России , а также работаем в рамках 275 ФЗ с открытием отдельных счетов в уполномоченном банке. Система менеджмента качества компании соответствует требованиям ГОСТ ISO 9001.

Минимальные сроки поставки, гибкие цены, неограниченный ассортимент и индивидуальный подход к клиентам являются основой для выстраивания долгосрочного и эффективного сотрудничества с предприятиями радиоэлектронной промышленности, предприятиями ВПК и научно-исследовательскими институтами России.

С нами вы становитесь еще успешнее!

### Наши контакты:

**Телефон:** +7 812 627 14 35

**Электронная почта:** [sales@st-electron.ru](mailto:sales@st-electron.ru)

**Адрес:** 198099, Санкт-Петербург,  
Промышленная ул, дом № 19, литера Н,  
помещение 100-Н Офис 331