



# CFast ArmourDrive™

91 Series

Product Brief

## Product Description

The CFast ArmourDrive™ family consists of high-reliability, industrial flash memory cards in a wide selection of capacities and endurance specifications. To better address customer needs, the 91 Series is available with 1-bit-per-cell (SLC), 2-bit-per-cell (MLC) or 3-bit-per-cell (TLC) 3D NAND configurations. ArmourDrive memory cards designed with Greenliant's EnduroSLC™ Technology can reach ultra-high write endurance of 250K+ program/erase (P/E) cycles. Operating at extreme temperatures, CFast ArmourDrive is ideal for applications requiring removable data storage able to withstand the most demanding environments.

The 91 Series implements advanced NAND flash management technology to preserve data integrity and extend memory card lifespan. Built in the standard CFast form factor and backed by Greenliant's technical support, CFast ArmourDrive gives industrial, medical, gaming, video and imaging customers added flexibility when selecting reliable, hot-swappable solid state storage for space-constrained, embedded systems.



## Key Features

### Form Factor and Interface

- 36.40mm x 42.85mm x 3.60mm
- Supports SATA 6Gb/s, 3Gb/s and 1.5Gb/s
- Compliant with SATA Revision 3.2

### High Performance

- Sequential Read / Write performance up to 550MB/s / 490MB/s
- Native Command Queuing up to 32 commands

### Energy Efficient

- 3.3V low power supply
- Standby Mode less than 325mW
- Sleep Mode less than 180mW
- DevSleep Mode support

### Data Security

- Secure Erase for quick data wipe/factory reset

### Pre-programmed Firmware

- Field-upgradeable firmware to add new features and enhance device performance
- Configurable algorithms optimize data retention based on the usage model
- Embedded FFS enables seamless capacity upgrade with no change to host software

### Advanced Flash Management

- Dynamic and static wear leveling algorithms maximize product lifespan
- Supports TRIM commands to remove invalid data which is no longer in use

### Bad Block Management

- Replaces bad blocks with spare blocks in the NAND flash to prevent uncorrectable errors

### Built-in ECC

- Uses advanced bit error detection and correction optimized for 3D NAND

### SSD Lifespan Monitoring

- Supports SMART command-based alerts indicating the remaining useful product life

### Power Interrupt Data Protection

- Helps prevent data loss during unexpected power failure events

### Wide Range of Capacities

- SLC (EX Series): 8 GB - 128 GB
- MLC (MX Series): 16 GB - 64 GB
- TLC (PX Series): 64 GB - 256 GB

### Full I-temp Capability

- Industrial operation: -40°C to +85°C



## Applications

- Transportation
- Vending machine
- Gaming
- Industrial PC
- Navigation
- Infotainment
- Digital signage
- Point-of-sales
- Security / Surveillance
- Industrial automation & control
- Data logger
- Healthcare
- Test & measurement
- Video conferencing
- Set-top box
- Professional video / photo

### Greenliant Systems

3970 Freedom Circle, Suite 100  
Santa Clara, CA 95054 USA  
Tel: 1-408-200-8000  
Fax: 1-408-200-8099

[www.Greenliant.com](http://www.Greenliant.com)

## CFast ArmourDrive Board Diagrams

36.40mm x 42.80mm x 3.60mm  
Pb-free (RoHS compliant)

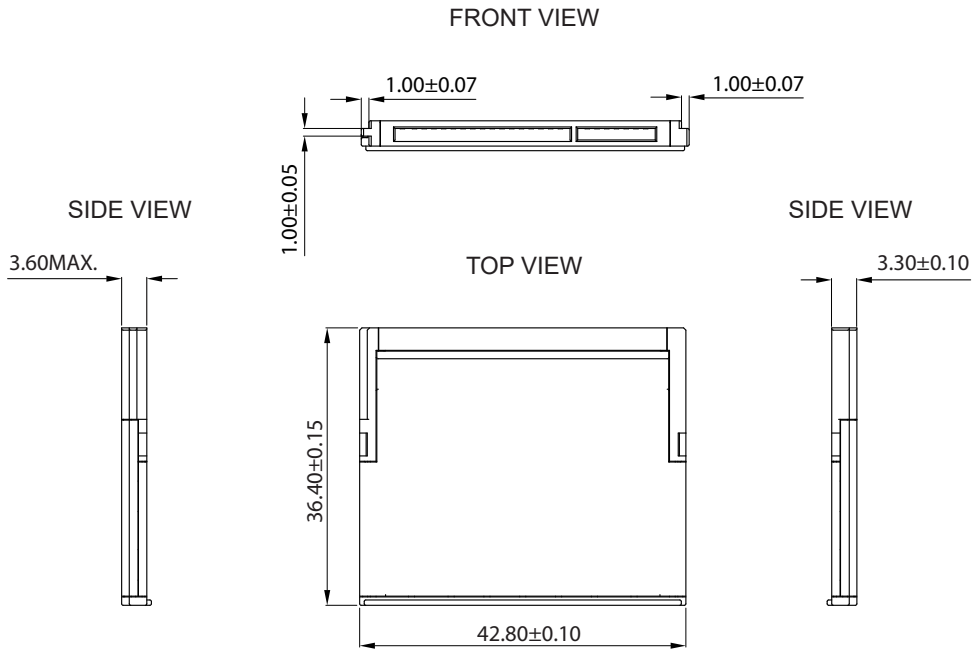

Note: All dimensions are in millimeters, unless otherwise specified.

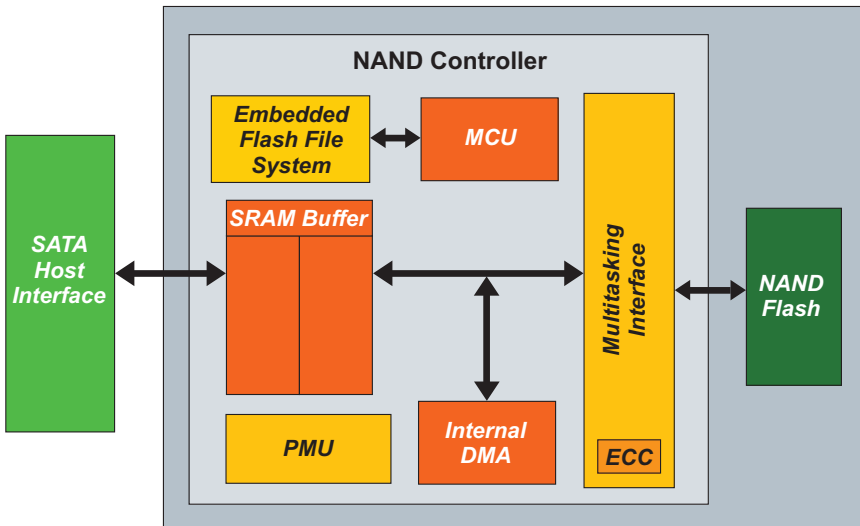

## CFast ArmourDrive Block Diagram



## Product Lineup

91 Series CFast ArmourDrive		
Product Series / Capacity	NAND Configuration / Endurance	Temperature Range
<b>EX</b> 8 GB - 128 GB	1 bit per cell (3D SLC) / 50K, 100K, 250K P/E cycles*	Industrial -40°C to +85°C
<b>MX</b> 16 GB - 64 GB	2 bits per cell (3D MLC) / 5K P/E cycles	
<b>PX</b> 64 GB - 256 GB	3 bits per cell (3D TLC) / 3K P/E cycles	

\*Designed with Greenliant's advanced EnduroSLC Technology **EnduroSLC™**  
250K, or higher, endurance offered up to 64GB  
EX and MX Series planned for production in 3Q19

 [twitter.com/Greenliant](https://twitter.com/Greenliant)  
 [linkedin.com/company/Greenliant-Systems](https://linkedin.com/company/Greenliant-Systems)  
 [facebook.com/Greenliant](https://facebook.com/Greenliant)

**ArmourDrive FAQs:** [www.greenliant.com/armourdrive-faqs](http://www.greenliant.com/armourdrive-faqs)

For more information, contact your Greenliant representative: [www.greenliant.com/sales](http://www.greenliant.com/sales)



© 2019 Greenliant  
Greenliant, the Greenliant logo, EnduroSLC and ArmourDrive are trademarks of Greenliant.  
These specifications are subject to change without notice. 05/2019



## Стандарт Электрон Связь

Мы молодая и активно развивающаяся компания в области поставок электронных компонентов. Мы поставляем электронные компоненты отечественного и импортного производства напрямую от производителей и с крупнейших складов мира.

Благодаря сотрудничеству с мировыми поставщиками мы осуществляем комплексные и плановые поставки широчайшего спектра электронных компонентов.

Собственная эффективная логистика и склад в обеспечивает надежную поставку продукции в точно указанные сроки по всей России.

Мы осуществляем техническую поддержку нашим клиентам и предпродажную проверку качества продукции. На все поставляемые продукты мы предоставляем гарантию .

Осуществляем поставки продукции под контролем ВП МО РФ на предприятия военно-промышленного комплекса России , а также работаем в рамках 275 ФЗ с открытием отдельных счетов в уполномоченном банке. Система менеджмента качества компании соответствует требованиям ГОСТ ISO 9001.

Минимальные сроки поставки, гибкие цены, неограниченный ассортимент и индивидуальный подход к клиентам являются основой для выстраивания долгосрочного и эффективного сотрудничества с предприятиями радиоэлектронной промышленности, предприятиями ВПК и научно-исследовательскими институтами России.

С нами вы становитесь еще успешнее!

### Наши контакты:

**Телефон:** +7 812 627 14 35

**Электронная почта:** [sales@st-electron.ru](mailto:sales@st-electron.ru)

**Адрес:** 198099, Санкт-Петербург,  
Промышленная ул, дом № 19, литера Н,  
помещение 100-Н Офис 331