

C8051F912 DEVELOPMENT KIT USER'S GUIDE

1. Relevant Devices

The C8051F912 Development Kit is intended as a development platform for the microcontrollers in the C8051F91x-C8051F90x MCU family. The members of this MCU family are C8051F912, C8051F911, C8051F902, and C8051F901.

Notes:

1. The target board included in this kit is provided with a pre-soldered C8051F912 MCU (QSOP24 package).
2. Code developed on the C8051F912 can be easily ported to the other members of this MCU family.
3. Refer to the C8051F91x-C8051F90x data sheet for the differences between the members of this MCU family.

2. Kit Contents

The C8051F912 Development Kit contains the following items:

- C8051F912 Target Board
- C8051Fxxx Development Kit Quick-Start Guide
- Silicon Laboratories IDE and Product Information CD-ROM. CD content includes the following:
 - Silicon Laboratories Integrated Development Environment (IDE)
 - Keil 8051 Development Tools (macro assembler, linker, evaluation C compiler)
 - Source code examples and register definition files
 - Documentation
 - C8051F912 Development Kit User's Guide (this document)
- AC to DC Power Adapter
- USB Debug Adapter (USB to Debug Interface)
- 2 USB Cables
- 2 AAA Batteries

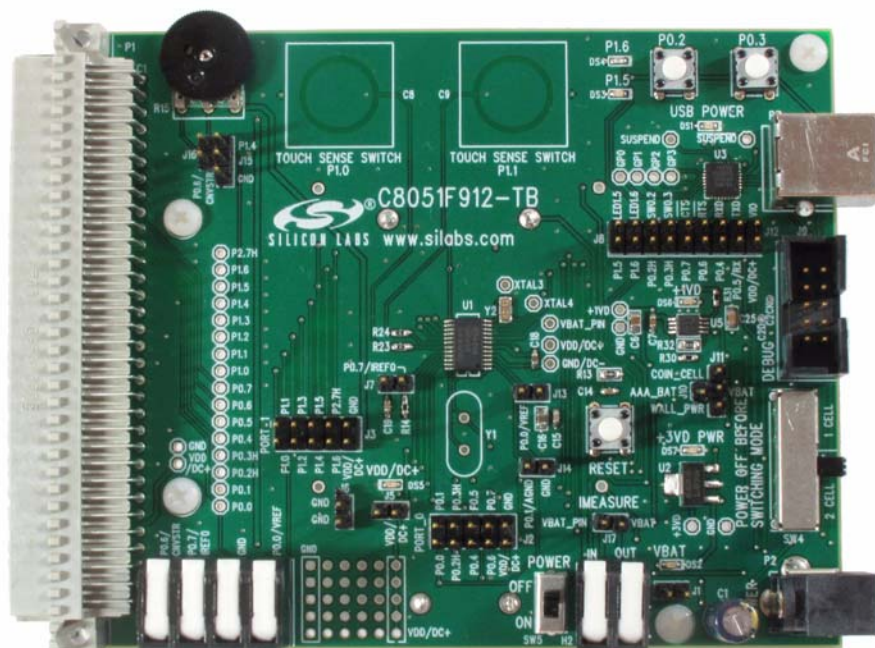

Figure 1. C8051F912 Target Board

C8051F912-DK

3. Software Overview

All software required to develop firmware and communicate with the target microcontroller is included in the CD-ROM. The CD-ROM also includes other useful software.

Below is the software necessary for firmware development and communication with the target microcontroller:

- Silicon Laboratories Integrated Development Environment (IDE)
- Keil 8051 Development Tools (macro assembler, linker, evaluation C compiler)

Other useful software that is provided in the CD-ROM includes the following:

- Configuration Wizard 2
- Keil μ Vision Drivers
- CP210x USB to UART Virtual COM Port (VCP) Drivers

3.1. Software Installation

The included CD-ROM contains the Silicon Laboratories Integrated Development Environment (IDE), Keil software 8051 tools and additional documentation. Insert the CD-ROM into your PC's CD-ROM drive. An installer will automatically launch, allowing you to install the IDE software or read documentation by clicking buttons on the Installation Panel. If the installer does not automatically start when you insert the CD-ROM, run *autorun.exe* found in the root directory of the CD-ROM. Refer to the *ReleaseNotes.txt* file on the CD-ROM for the latest information regarding known problems and restrictions. After installing the software, see the following sections for information regarding the software and running one of the demo applications.

3.2. CP210x USB to UART VCP Driver Installation

The C8051F912 Target Board includes a Silicon Laboratories CP2103 USB-to-UART Bridge Controller. Device drivers for the CP2103 need to be installed before PC software such as HyperTerminal can communicate with the target board over the USB connection. If the "Install CP210x Drivers" option was selected during installation, this will launch a driver "unpacker" utility.

1. Follow the steps to copy the driver files to the desired location. The default directory is *C:\SiLabs\MCU\CP210x*.
2. The final window will give an option to install the driver on the target system. Select the "Launch the CP210x VCP Driver Installer" option if you are ready to install the driver.
3. If selected, the driver installer will now launch, providing an option to specify the driver installation location. After pressing the "Install" button, the installer will search your system for copies of previously installed CP210x Virtual COM Port drivers. It will let you know when your system is up to date. The driver files included in this installation have been certified by Microsoft.
4. If the "Launch the CP210x VCP Driver Installer" option was not selected in step 3, the installer can be found in the location specified in step 2, by default *C:\SiLabs\MCU\CP210x\Windows_2K_XP_S2K3_Vista*. At this location run *CP210xVCPInstaller.exe*.
5. To complete the installation process, connect the included USB cable between the host computer and the USB connector (P3) on the C8051F912 Target Board. Windows will automatically finish the driver installation. Information windows will pop up from the taskbar to show the installation progress.
6. If needed, the driver files can be uninstalled by selecting "Silicon Laboratories CP210x USB to UART Bridge (Driver Removal)" option in the "Add or Remove Programs" window.

3.3. Silicon Laboratories IDE

The Silicon Laboratories IDE integrates a source-code editor, a source-level debugger, and an in-system Flash programmer. See Section 5. "Using the Keil Software 8051 Tools with the Silicon Laboratories IDE," on page 9 for detailed information on how to use the IDE. The Keil Evaluation Toolset includes a compiler, linker, and assembler and easily integrates into the IDE. The use of third-party compilers and assemblers is also supported.

3.3.1. IDE System Requirements

The Silicon Laboratories IDE requirements:

- Pentium-class host PC running Microsoft Windows 2000 or newer
- One available USB port
- 64 MB RAM and 40 MB free HD space recommended

3.3.2. 3rd Party Toolsets

The Silicon Laboratories IDE has native support for many 8051 compilers. The full list of natively supported tools is as follows:

- Keil
- IAR
- Raisonance
- Tasking
- Hi-Tech
- SDCC

The demo applications for the C8051F912 target board are written to work with the Keil and SDCC toolsets.

3.4. Keil Evaluation Toolset

3.4.1. Keil Assembler and Linker

The Keil demonstration toolset assembler and linker place no restrictions on code size.

3.4.2. Keil Evaluation C51 C Compiler

The evaluation version of the C51 compiler is the same as the full version with the following limitations: (1) Maximum 4 kB code generation, (2) There is no floating point library included. When installed from the CD-ROM, the C51 compiler is initially limited to a code size of 2 kB, and programs start at code address 0x0800. Refer to "AN104: Integrating Keil Tools into the Silicon Labs IDE" for instructions to change the limitation to 4 kB and have the programs start at code address 0x0000.

3.6. Silicon Labs Battery Life Estimator

The Battery Life Estimator is a system design tool for battery operated devices. It allows the user to select the type of battery they are using in the system and enter the supply current profile of their application. Using this information, it performs a simulation and provides an estimated system operating time. The Battery Life Estimator is shown in Figure 3.

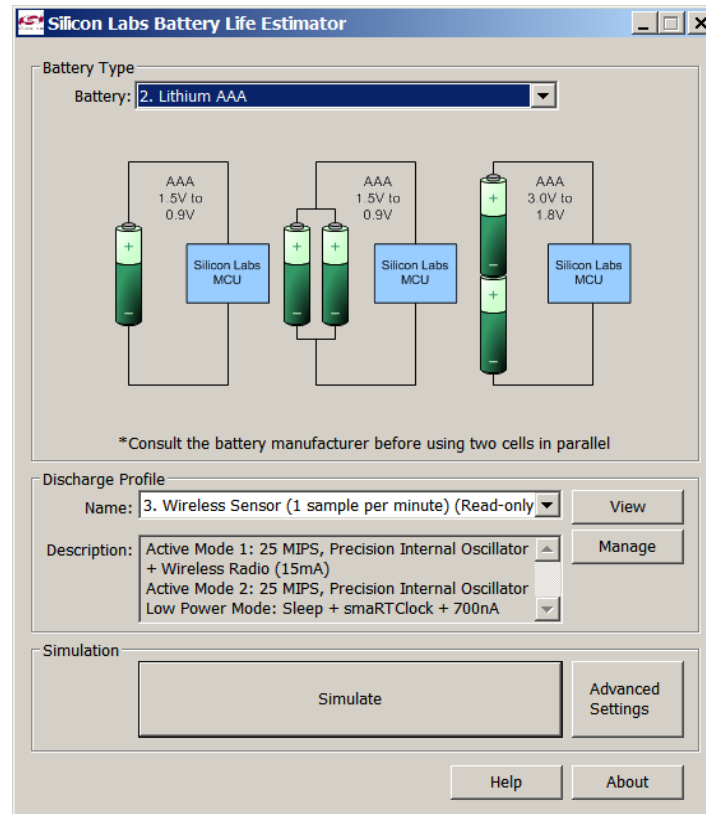

Figure 3. Battery Life Estimator Utility

From Figure 3, the two inputs to the Battery Life Estimator are battery type and discharge profile. The utility includes battery profiles for common battery types such as AAA, AA, A76 Button Cell, and CR2032 coin cell. The discharge profile is application-specific and describes the the supply current requirements of the system under various supply voltages and battery configurations. The discharge profile is independent of the selected power source. Several read-only discharge profiles for common applications are included in the pulldown menu. The user may also create a new profile for their own applications.

To create a new profile:

1. Select the profile that most closely matches the target application or choose the "Custom Profile".
2. Click Manage
3. Click Duplicate
4. Click Edit

Profiles may be edited with the easy-to-use GUI (shown in Figure 4).

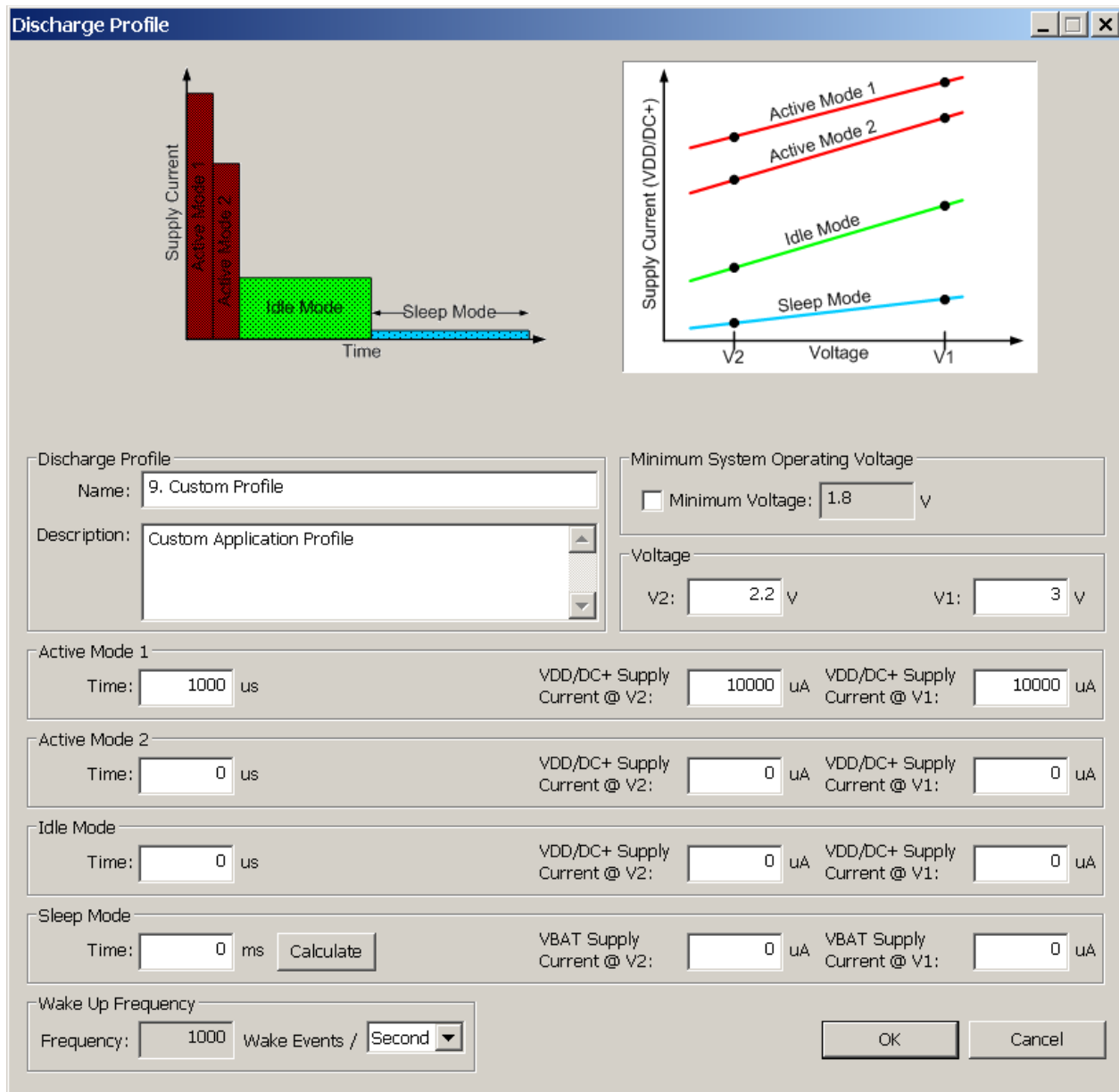

Figure 4. Battery Life Estimator Discharge Profile Editor

The Discharge Profile Editor allows the user to modify the profile name and description. The four text entry boxes on the left hand side of the form allow the user to specify the amount of time the system spends in each power mode. On the right hand side, the user may specify the supply current of the system in each power mode.

Since supply current is typically dependent on supply voltage, the discharge profile editor provides two columns for supply current. The V2 and V1 voltages at the top of the two columns specify the voltages at which the current measurements were taken. The Battery Life Estimator creates a linear approximation based on the input data and is able to feed the simulation engine with an approximate supply current demand for every input voltage.

The minimum system operating voltage input field allows the system operating time to stop increasing when the simulated battery voltage drops below a certain threshold. This is primarily to allow operating time estimates for systems that cannot operate down to 1.8 V, which is the voltage of two fully drained single-cell batteries placed in series.

The wakeup frequency box calculates the period of a single iteration through the four power modes and displays the system wake up frequency. This is typically the "sample rate" in low power analog sensors.

Once the battery type and discharge profile is specified, the user can click the "Simulate" button to start a new simulation. The simulation engine calculates the estimated battery life when using one single-cell battery, two single-cell batteries in series, and two single-cell batteries in parallel. Figure 5 shows the simulation output window.

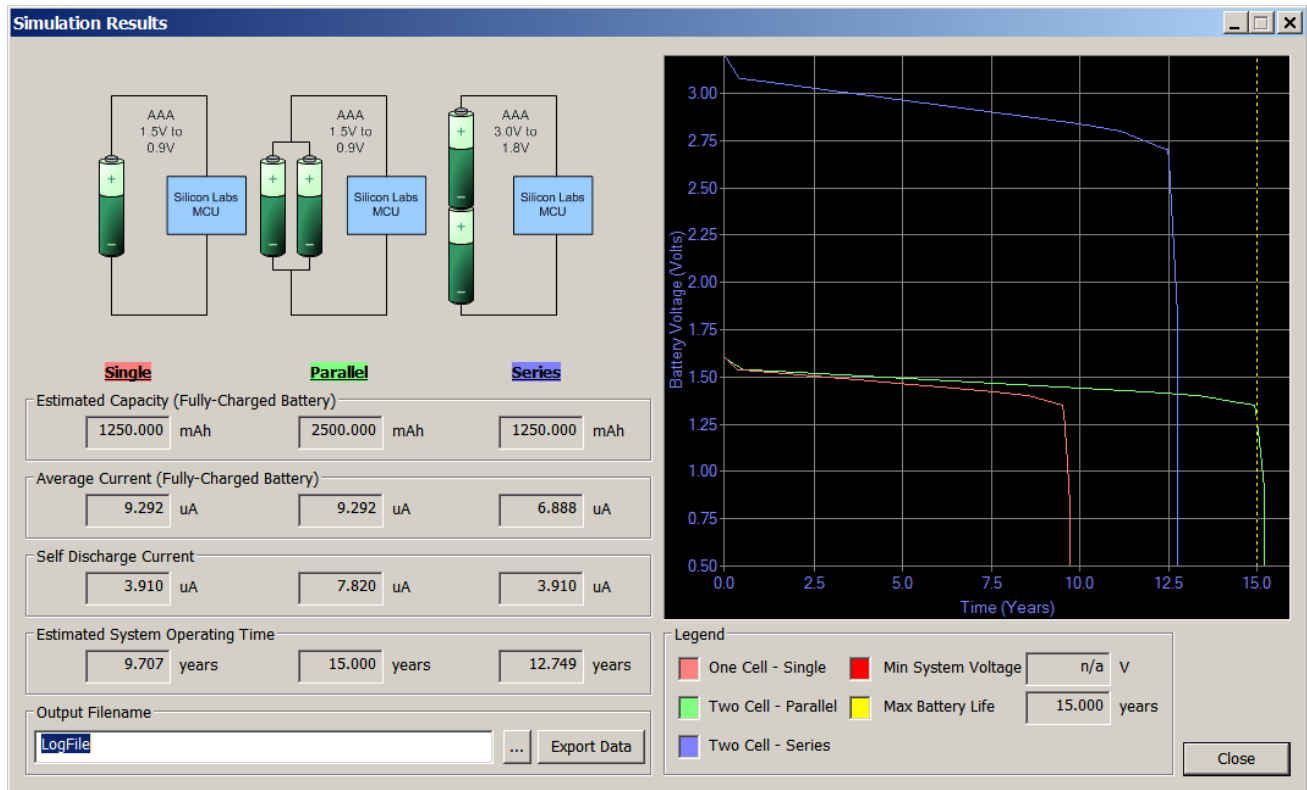

Figure 5. Battery Life Estimator Utility Simulation Results Form

The primary outputs of the Battery Life Estimator are an estimated system operating time and a simulated graph of battery voltage vs. time. Additional outputs include estimated battery capacity, average current, self-discharge current, and the ability to export graph data to a comma delimited text file for plotting in an external graphing application.

3.7. Keil μ Vision2 and μ Vision3 Silicon Laboratories Drivers

As an alternative to the Silicon Laboratories IDE, the μ Vision debug driver allows the Keil μ Vision2 and μ Vision3 IDEs to communicate with Silicon Laboratories' on-chip debug logic. In-system Flash memory programming integrated into the driver allows for rapid updating of target code. The μ Vision2 and μ Vision3 IDEs can be used to start and stop program execution, set breakpoints, check variables, inspect and modify memory contents, and single-step through programs running on the actual target hardware. For more information, refer to the μ Vision driver documentation. The documentation and software are available on the kit CD and from the downloads webpage: www.silabs.com/mcudownloads.

4. Hardware Setup using a USB Debug Adapter

The target board is connected to a PC running the Silicon Laboratories IDE via the USB Debug Adapter as shown in Figure 6.

1. Connect the USB Debug Adapter to the DEBUG connector on the target board with the 10-pin ribbon cable.
2. Connect one end of the USB cable to the USB connector on the USB Debug Adapter.
3. Verify that a shorting block is installed on J17 and that SW5 is in the ON position.
4. Connect the other end of the USB cable to a USB Port on the PC.
5. Connect the ac/dc power adapter to power jack P2 on the target board (Optional).

Notes:

- Use the Reset button in the IDE to reset the target when connected using a USB Debug Adapter.
- Remove power from the target board and the USB Debug Adapter before connecting or disconnecting the ribbon cable from the target board. Connecting or disconnecting the cable when the devices have power can damage the device and/or the USB Debug Adapter.

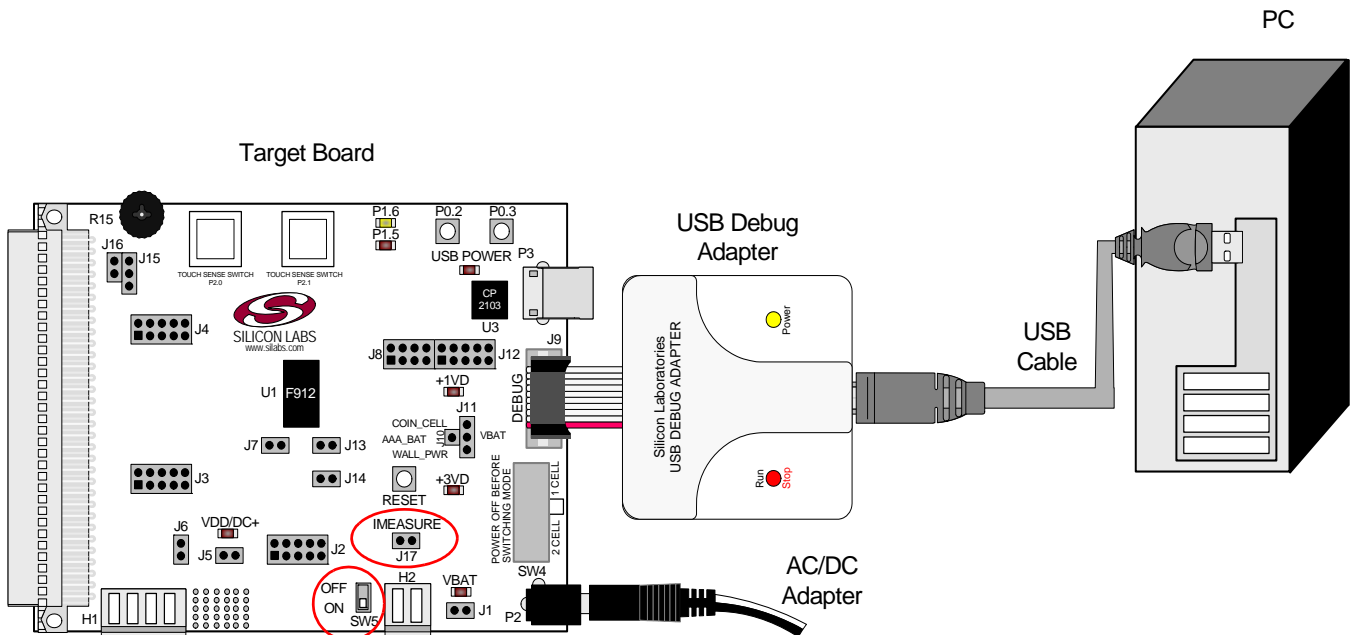

Figure 6. Hardware Setup using a USB Debug Adapter

5. Using the Keil Software 8051 Tools with the Silicon Laboratories IDE

To perform source-level debugging with the IDE, configure the Keil 8051 tools to generate an absolute object file in the OMF-51 format with object extensions and debug records enabled. Build the OMF-51 absolute object file by calling the Keil 8051 tools at the command line (e.g., batch file or make file) or by using the project manager built into the IDE. The default configuration when using the Silicon Laboratories IDE project manager enables object extension and debug record generation. Refer to "AN104: Integrating Keil 8051 Tools into the Silicon Labs IDE" in the "*SiLabs\MCU\Documentation\ApplicationNotes*" directory on the CD-ROM for additional information on using the Keil 8051 tools with the Silicon Laboratories IDE.

To build an absolute object file using the Silicon Laboratories IDE project manager, you must first create a project. A project consists of a set of files, IDE configuration, debug views, and a target build configuration (list of files and tool configurations used as input to the assembler, compiler, and linker when building an output object file).

The following sections illustrate the steps necessary to manually create a project with one or more source files, build a program, and download it to the target in preparation for debugging. (The IDE will automatically create a single-file project using the currently open and active source file if you select Build/Make Project before a project is defined.)

5.1. Creating a New Project

1. Select Project→New Project to open a new project and reset all configuration settings to default.
2. Select File→New File to open an editor window. Create your source file(s) and save the file(s) with a recognized extension, such as .c, .h, or .asm, to enable color syntax highlighting.
3. Right-click on "New Project" in the Project Window. Select Add files to project. Select files in the file browser and click Open. Continue adding files until all project files have been added.
4. For each of the files in the Project Window that you want assembled, compiled and linked into the target build, right-click on the file name and select Add file to build. Each file will be assembled or compiled as appropriate (based on file extension) and linked into the build of the absolute object file.
5. If a project contains a large number of files, the "Group" feature of the IDE can be used to organize. Right-click on "New Project" in the Project Window. Select Add Groups to project. Add pre-defined groups or add customized groups. Right-click on the group name and choose Add file to group. Select files to be added. Continue adding files until all project files have been added.

5.2. Building and Downloading the Program for Debugging

1. Once all source files have been added to the target build, build the project by clicking on the Build/Make Project button in the toolbar or selecting Project→Build/Make Project from the menu.

Note: After the project has been built the first time, the Build/Make Project command will only build the files that have been changed since the previous build. To rebuild all files and project dependencies, click on the Rebuild All button in the toolbar or select Project→Rebuild All from the menu.

2. Before connecting to the target device, several connection options may need to be set. Open the Connection Options window by selecting Options→Connection Options... in the IDE menu. First, select the appropriate adapter in the “Serial Adapter” section. Next, the correct “Debug Interface” must be selected. C8051F91x-C8051F90x family devices use the Silicon Labs 2-wire (C2) debug interface. Once all the selections are made, click the OK button to close the window.
3. Click the Connect button in the toolbar or select Debug→Connect from the menu to connect to the device.
4. Download the project to the target by clicking the Download Code button in the toolbar.

Note: To enable automatic downloading if the program build is successful select Enable automatic connect/download after build in the Project→Target Build Configuration dialog. If errors occur during the build process, the IDE will not attempt the download.

5. Save the project when finished with the debug session to preserve the current target build configuration, editor settings and the location of all open debug views. To save the project, select Project→Save Project As... from the menu. Create a new name for the project and click on Save.

6. Example Source Code

Example source code and register definition files are provided in the “*SiLabs\MCU\Examples\C8051F91x_90x*” default directory during IDE installation. These files may be used as a template for code development. Example applications include a blinking LED example which configures the green LED on the target board to blink at a fixed rate.

6.1. Register Definition Files

Register definition files *C8051F912.inc* and *C8051F912_defs.h* define all SFR registers and bit-addressable control/status bits. A macro definition header file *compiler_defs.h* is also included, and is required to be able to use the *C8051F912_defs.h* header file with various tool chains. These files are installed into the “*SiLabs\MCU\Examples\C8051F91x_90x\Header_Files*” directory during IDE installation by default. The register and bit names are identical to those used in the C8051F91x-C8051F90x data sheet. These register definition files are also installed in the default search path used by the Keil Software 8051 tools. Therefore, when using the Keil 8051 tools included with the development kit (A51, C51), it is not necessary to copy a register definition file to each project’s file directory.

6.2. Blinking LED Example

The example source files *F91x_Blinky.asm* and *F91x_Blinky.c* installed in the default directory “*SiLabs\MCU\Examples\C8051F91x_90x\Blinky*” show examples of several basic C8051F912 functions. These include disabling the watchdog timer (WDT), configuring the Port I/O crossbar, configuring a timer for an interrupt routine, initializing the system clock, and configuring a GPIO port pin. When compiled/assembled and linked this program flashes the green LED on the C8051F912 Target Board about five times a second using the interrupt handler with a C8051F912 timer.

6.3. Touch Sensitive Switch Example

The example source file *F91x_CapTouchSense_Switch.c* demonstrates the configuration and usage of the touch sensitive (contactless) switches located on P1.0 and P1.1. Refer to the source file for step-by-step instructions to build and test this example. This is installed in the “*SiLabs\MCU\Examples\C8051F91x_90x\CapTouchSense_Switch*” directory by default.

The following items are located on the bottom side of the board. See Figure 8.

- BT1 Battery Holder for 1.5 V AAA. Use for one-cell or two-cell mode.
- BT2 Battery Holder for 1.5 V AAA. Use for two-cell mode only.
- BT3 Battery Holder for 3 V Coin Cell (CR2032).
- BT4 Battery Holder for 1.5 V Button Cell (A76 or 357).

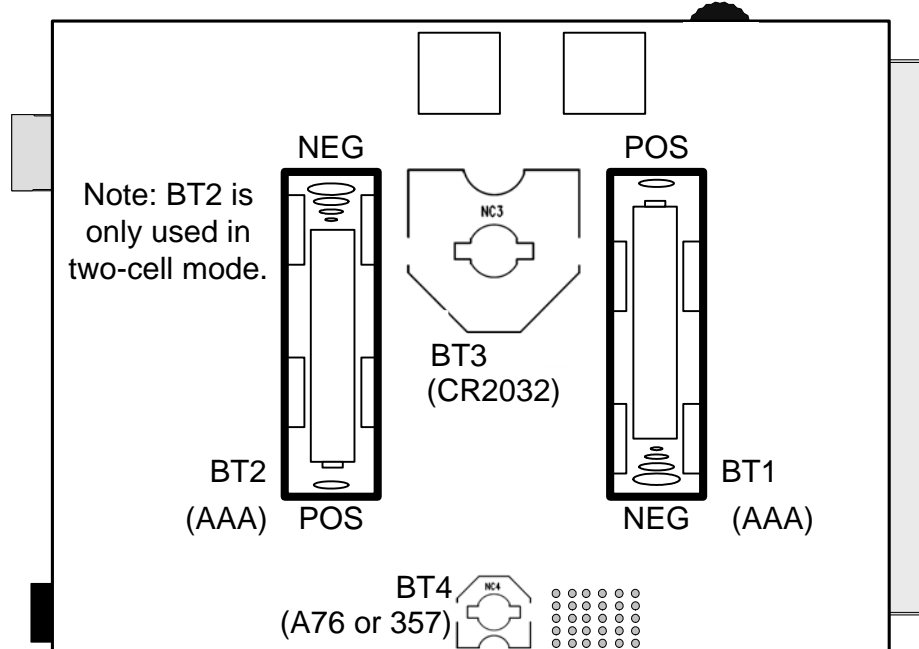

Figure 8. Bottom of C8051F912 Target Board

C8051F912-DK

7.1. Target Board Shorting Blocks: Factory Defaults

The C8051F912 Target Board comes from the factory with pre-installed shorting blocks on many headers. Figure 9 shows the positions of the factory default shorting blocks.

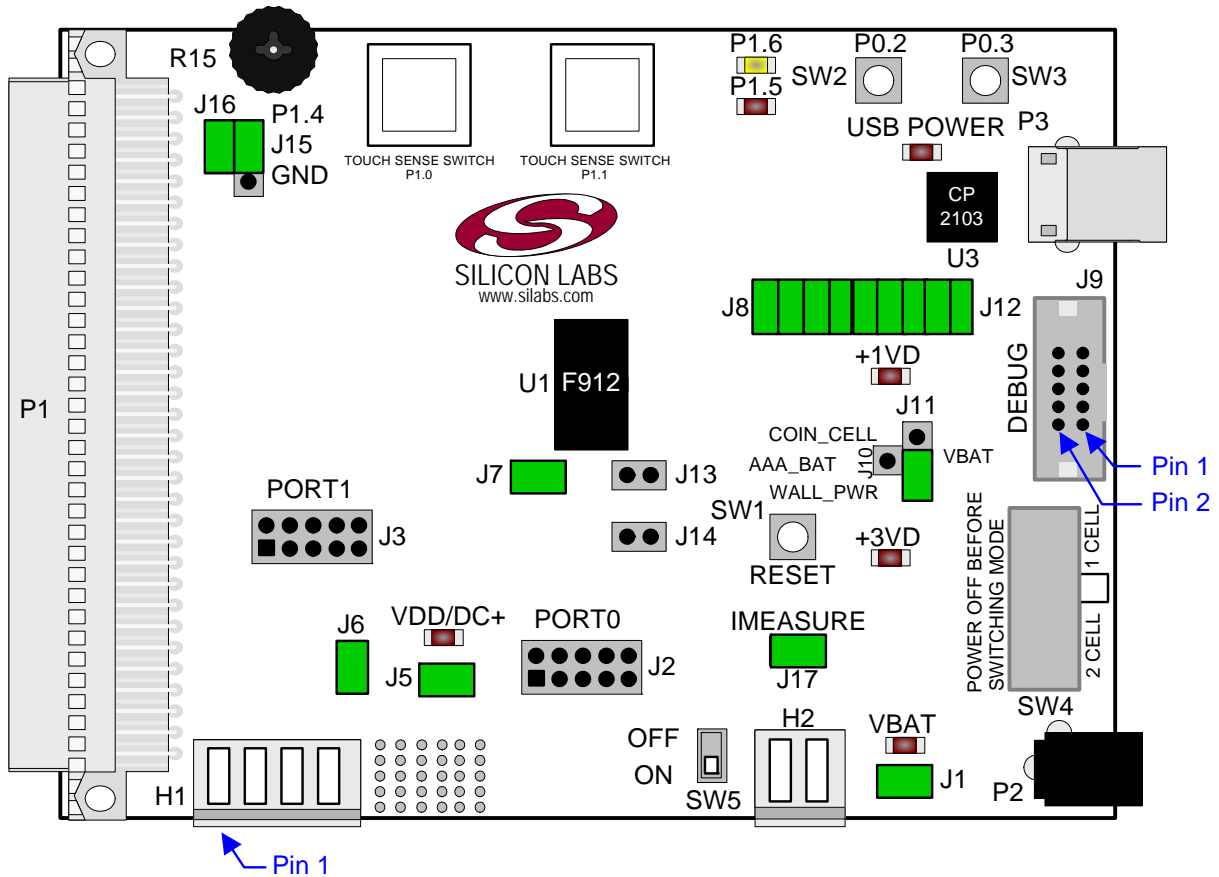

Figure 9. C8051F912 Target Board Shorting Blocks: Factory Defaults

7.2. Target Board Power Options and Current Measurement (J10, J11, J17, H2, P2, P3, SW4, SW5)

The C8051F912 Target Board supports three power options, selectable by the three-way header (J10/J11). The power options vary based on the configuration (one-cell or two-cell mode) selected by SW4. Power to the MCU may be switched on/off using the power switch (SW5). **Important Note: The power switch (SW5) must be in the OFF position prior to switching between one-cell and two-cell mode using SW4.** The power options are described in the paragraphs below.

7.2.1. Wall Power

When the J10/J11 three-way header is set to WALL_PWR, the C8051F912 Target Board may be powered from the following power sources:

- 9 VDC power using the ac to dc power adapter (P2)
- 5 VDC USB VBUS power from PC via the USB Debug Adapter (J9)
- 5 VDC USB VBUS power from PC via the CP2103 USB connector (P3)

All the three power sources are ORed together using reverse-biased diodes (D1, D2, D3), eliminating the need for headers to choose between the sources. The target board will operate as long as any one of the power sources is present. The ORed power is regulated to a 3.3 V dc voltage using a LDO regulator (U2). The output of the regulator powers the +3 VD net on the target board.

If SW4 is configured to select two-cell mode, the VBAT supply net on the target board is powered directly from the +3 VD net. If SW4 is configured to select one-cell mode, the VBAT supply net is powered directly from the +1 VD. This power supply net takes +3 VD and passes it through a 1.65 V LDO. The LDO's output voltage is variable and can be set by changing the value of resistor R32.

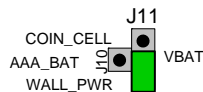

7.2.2. AAA Battery

When the J10/J11 three-way header is set to AAA_BAT, the C8051F912 Target Board may be powered from a single AAA battery inserted in BT1 or from the series combination of the AAA batteries inserted in BT1 and BT2. A single battery is selected when SW4 is configured to one-cell mode. The two AAA batteries configured in series to provide a voltage of ~3 V are selected when SW4 is configured to two-cell mode.

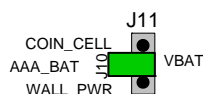

7.2.3. Coin Cell Battery

When the J10/J11 three-way header is set to COIN_CELL, the C8051F912 Target Board may be powered from a single 1.5 V Alkaline (A76) or Silver Oxide (357) button cell inserted in BT4 or from a single 3 V Lithium (CR2032) coin cell inserted in BT3. The button cell (BT4) is selected when SW4 is configured to one-cell mode, and the coin cell (BT3) is selected when SW4 is configured to two-cell mode.

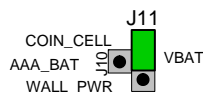

7.2.4. Measuring Current

The header (J17) and terminal block (H2) provide a way to measure the total supply current flowing from the power supply source to the MCU. The measured current does not include any current from the VBAT LED (DS2), the address latch (U4) or the quiescent current from the power supply; however, it does include the current used by any LEDs powered from the VDD/DC+ supply net or sourced through a GPIO pin. See the target board schematic in Figure 10 through Figure 12 for additional information.

7.3. System Clock Sources

7.3.1. Internal Oscillators

The C8051F912 device installed on the target board features a factory calibrated programmable high-frequency internal oscillator (24.5 MHz base frequency, $\pm 2\%$) and a low power internal oscillator (20 MHz $\pm 10\%$). After each reset, the low power oscillator divided by 8 results in a default system clock frequency of 2.5 MHz ($\pm 10\%$). The selected system clock and the system clock divider may be configured by software for operation at other frequencies. For low-frequency operation, the C8051F912 features a smaRTClock real time clock. A 32.768 kHz Watch crystal (Y2) is included on the target board. If you wish to operate the C8051F912 device at a frequency not available with the internal oscillators, an external crystal may be used. Refer to the C8051F91x-C8051F90x data sheet for more information on configuring the system clock source.

7.3.2. External Oscillator Options

The target board is designed to facilitate the installation of an external crystal (Y1). Install a 10 M Ω resistor at R9 and install capacitors at C20 and C21 using values appropriate for the crystal you select. If you wish to operate the external oscillator in capacitor or RC mode, options to install a capacitor or an RC network are also available on the target board. Populate C21 for capacitor mode, and populate R16 and C21 for RC mode. Refer to the C8051F91x-C8051F90x data sheet for more information on the use of external oscillators.

7.4. Port I/O Headers (J2, J3, J6)

Access to all Port I/O on the C8051F912 is provided through the headers J2 and J3. The header J6 provides access to the ground plane for easy clipping of oscilloscope probes.

7.5. Switches and LEDs (J1, J5, J8, J15, J16)

Three push-button switches are provided on the target board. Switch SW1 (RESET) is connected to the reset pin of the C8051F912. Pressing SW1 puts the device into its hardware-reset state. Switches SW2 (P0.2) and SW3 (P0.3) are connected to the C8051F912's general purpose I/O (GPIO) pins through headers. Pressing SW2 or SW3 generates a logic low signal on the port pin. Remove the shorting block from the header (J8) to disconnect the switches from the port pins. The port pin signal is also routed to pins on the J2 and P1 I/O connectors. See Table 1 for the port pins and headers corresponding to each switch.

Two touch sensitive (contactless) switches are provided on the target board. The operation of these switches require appropriate firmware running on the C8051F912 MCU that can sense the state of the switch. See Section 6.3. "Touch Sensitive Switch Example," on page 11 for details about example source code.

Five power LEDs are provided on the target board to serve as indicators. Each of the two regulators has a red LED used to indicate the presence of power at the output of the regulator. A red USB Power LED turns on when a USB cable is plugged into the USB connector P3. One power LED is also added to each of the two primary supply nets powering the MCU (VDD/DC+ and VBAT). The LEDs connected to the supply nets may be disabled by removing the shorting blocks from J1 and J5.

Two LEDs are connected to GPIO pins P1.5 and P1.6 for use by application software. See Table 1 for the port pins and headers corresponding to each LED.

A potentiometer (R15) is also provided on the target board for generating analog signals. Place a shorting block on J16 to connect the wiper to P0.6/CNVSTR. The header J15 allows the negative terminal of the potentiometer to be tied to GND or to P1.4. When tied to GND, the potentiometer is always enabled and will draw a measurable amount of supply current. When tied to P1.4, it only draws current when P1.4 is driving a logic 0 and draws no current when P1.4 is driving a logic 1.

Table 1. Target Board I/O Descriptions

Description	I/O	Header(s)
SW1	Reset	none
SW2	P0.2	J8[5–6]
SW3	P0.3	J8[7–8]
P1.0 (Touch Sense Switch)	P1.0	none
P1.1 (Touch Sense Switch)	P1.1	none
Red LED (P1.5)	P1.5	J8[1–2]
Yellow LED (P1.6)	P1.6	J8[3–4]
Red LED (VDD/DC+)	VDD/DC+ Supply Net	J5
Red LED (VBAT)	VBAT Supply Net	J1
Red LED (USB Power)	USB VBUS	none
Red LED (+1 VD Power)	+1 VD Regulator Output	none
Red LED (+3 VD Power)	+3 VD Regulator Output	none
Potentiometer (R15)	P0.6/P1.4	J15, J16

C8051F912-DK

7.6. Expansion I/O Connector (P1)

The 96-pin Expansion I/O connector P1 provides access to all signal pins of the C8051F912 device (except the C2 debug interface signals). In addition, power supply and ground pins are included. A small through-hole prototyping area is also provided. See Table 2 for a list of pin descriptions for P1.

Table 2. P1 Pin Descriptions

Row A Pin #	Description	Row B Pin #	Description	Row C Pin #	Description
1	+3 VD	1	GND	1	nc
2	nc	2	nc	2	nc
3	nc	3	nc	3	nc
4	nc	4	nc	4	nc
5	nc	5	nc	5	nc
6	nc	6	nc	6	nc
7	nc	7	nc	7	nc
8	nc	8	nc	8	nc
9	nc	9	nc	9	nc
10	nc	10	P0.7/IREF0	10	P0.6/CNVSTR
11	P0.5/RX	11	P0.4/TX	11	P0.3H
12	P0.2H	12	P0.1/AGND	12	P0.0/VREF
13	P2.7H	13	P1.6	13	P1.5
14	P1.4	14	P1.3	14	P1.2
15	P1.1	15	P1.0	15	nc
16	nc	16	nc	16	nc
17	nc	17	nc	17	nc
18	nc	18	nc	18	nc
19	nc	19	nc	19	nc
20	nc	20	nc	20	nc
21	nc	21	nc	21	nc
22	nc	22	nc	22	nc
23	nc	23	nc	23	nc
24	nc	24	nc	24	nc
25	nc	25	GND	25	nc
26	GND	26	nc	26	nc
27	nc	27	nc	27	nc
28	nc	28	VDD/DC+	28	VBAT
29	nc	29	nc	29	nc
30	nc	30	nc	30	nc
31	nc	31	nc	31	nc
32	nc	32	GND	32	nc

7.7. Target Board DEBUG Interface (J9)

The DEBUG connector J9 provides access to the DEBUG (C2) pins of the C8051F912. It is used to connect the Serial Adapter or the USB Debug Adapter to the target board for in-circuit debugging and Flash programming. Table 3 shows the DEBUG pin definitions.

Table 3. DEBUG Connector Pin Descriptions

Pin #	Description
1	+3 VD (+3.3 VDC)
2, 3, 9	GND (Ground)
4	P2.7/C2D
5	$\overline{\text{RST}}$ (Reset)
6	P2.7
7	$\overline{\text{RST}}/\text{C2CK}$
8	Not Connected
10	USB Power (+5 VDC from J9)

7.8. Serial Interface (J12)

A USB-to-UART bridge circuit (U3) and USB connector (P3) are provided on the target board to facilitate serial connections to UART0 of the C8051F912. The Silicon Labs CP2103 (U3) USB-to-UART bridge provides data connectivity between the C8051F912 and the PC via a USB port. The VIO power supply and TX, RX, RTS and CTS signals of UART0 may be connected to the CP2103 by installing shorting blocks on header J12. The shorting block positions for connecting each of these signals to the CP2103 are listed in Table 4. To use this interface, the USB-to-UART device drivers should be installed as described in Section 3.2. "CP210x USB to UART VCP Driver Installation," on page 2.

Table 4. Serial Interface Header (J12) Description

Header Pins	UART0 Pin Description
J12[9–10]	CP2103_VIO (VDD/DC+)
J12[7–8]	TX_MCU (P0.5)
J12[5–6]	RX_MCU (P0.4)
J12[3–4]	RTS (P0.6)
J12[1–2]	CTS (P0.7)

7.9. Analog I/O (H1)

Several of the C8051F912 target device's port pins are connected to the H1 terminal block. Refer to Table 5 for the H1 terminal block connections.

Table 5. H1 Terminal Block Pin Descriptions

Pin #	Description
1	P0.6/CNVSTR
2	P0.7/IREF0
3	GND (Ground)
4	P0.0/ V_{REF} (Voltage Reference)

C8051F912-DK

7.10. IREF Connector (J7)

The C8051F912 Target Board also features a current-to-voltage 1 k Ω load resistor that may be connected to the current reference (IREF0) output that can be enabled on port pin (P0.7). Install a shorting block on J7 to connect port pin P0.7 of the target device to the load resistor. If enabled by software, the IREF0 signal is then routed to the J2[8] and H1[2] connectors.

7.11. VREF and AGND Connector (J13, J14)

The C8051F912 Target Board also features 4.7 μ F capacitor in parallel with a 0.1 μ F that can be connected to P0.0/VREF when using the Precision Voltage Reference. The capacitors are connected to P0.0/VREF when a shorting block is installed on J13. Using the Precision Voltage Reference is optional since 'F91x-'F90x devices have an on-chip High-Speed Voltage Reference.

The shorting block J14 allows P0.1/AGND to be connected to ground. This provides a noise-free ground reference to the analog-to-digital Converter. The use of this dedicated analog ground is optional.

7.12. C2 Pin Sharing

On the C8051F912, the debug pins C2CK and C2D are shared with the pins $\overline{\text{RST}}$ and P2.7, respectively. The target board includes the resistors necessary to enable pin sharing which allow the $\overline{\text{RST}}$ and P2.7 pins to be used normally while simultaneously debugging the device. See Application Note “AN124: Pin Sharing Techniques for the C2 Interface” at www.silabs.com for more information regarding pin sharing.

8. Frequently Asked Questions

1. Should power be turned off when switching between one-cell and two-cell mode?

Yes, power must be turned off by placing SW5 in the OFF position when switching between one-cell and two-cell mode. Switching between modes while power is on may result in increased power consumption and possible damage to low voltage transistors.

2. I have placed the MCU in Sleep Mode. Why is the supply current greater than 1 μA ?

This can be caused by a number of factors. Check the following:

- Verify that the USB Debug Adapter is not connected to the device. When connected, it can draw approximately 2–5 μA from the VDD/DC+ supply net.
- Verify that the P1.5 and P1.6 LEDs are turned off in software (P1.5 and P1.6 set to logic HIGH). Alternatively, the P1.5 and P1.6 LEDs can be disabled by removing the corresponding shorting blocks from J8.
- Verify that the VDD/DC+ Power LED is disabled (remove shorting block from J5).
- Verify that the shorting block on J15 does not connect the potentiometer negative terminal to GND, since this would result in continuous current of $\sim 300 \mu\text{A}$. The shorting block may be removed, or configured to enable the potentiometer when P1.4 is set to logic LOW. When the potentiometer enable is under software control, be sure to set P1.4 to logic HIGH prior to placing the device in Sleep Mode.
- Verify that J7, J13, and J14 do not have shorting blocks installed.

3. I have been measuring the sleep mode current using the “ μA ” setting on my multimeter. Why am I no longer able to connect to the IDE?

When most multimeters are placed in “ μA ” mode, a large resistance is placed in series with the power supply. This “current limiting” resistor prevents the MCU from starting up. To measure current during startup, make sure that the multimeter is configured to its “mA” setting.

Alternatively, a shorting block can be placed on J17 to ensure that the multimeter does not limit current during startup.

4. Where can I find a schematic of the C8051F912 Target Board?

A target board schematic can be found in the C8051F912-DK User's Guide which is available on the Development Tools CD and is installed in the following folder (by default):

C:\SiLabs\MCU\Documentation\UsersGuides

5. Which power LED should I use to determine if the MCU is powered?

The VDD/DC+ LED (DS5) should be used to determine if the MCU is powered. If you have applied power to the board, but the VDD/DC+ LED is not turning on, check the following:

- Verify that the correct power source (J10, J11) is selected.
- Verify that J17 has a shorting block.
- Verify that SW5 is in the ON position.
- Verify that J5 has a shorting block installed.

6. What can I do to reduce active supply current?

Below are some suggestions for reducing the active supply current:

- a. Clear all wake-up sources in the PCU0CF register. This will allow the low power oscillator to be disabled when it is not being used as the system clock. This optimization can reduce the supply current by up to 30 μ A.
- b. When operating at system clock frequencies above 10 MHz, minimize supply current by setting the BYPASS bit (FLSCL.6) to 1. If the system clock needs to decrease below 10 MHz, clear the BYPASS bit to 0.
- c. If the precision oscillator is not being used, turn off the precision oscillator bias by setting the OSCBIAS bit (REG0CN.4) to 0.

7. Why does P0.7/IREF0 have a voltage of 200 mV when IREF0CN is set to 0x00?

When IREF0CN is set to 0x00, the current reference is completely turned off. When a shorting block is installed on J7, the voltage at P0.7/IREF0 should be 0 V unless one of the following conditions is present:

- a. The P0.7/IREF0 pin is not configured for analog I/O (weak pull-up enabled).
- b. The P0.7/IREF0 pin is being used as $\overline{\text{CTS}}$ (a shorting block is installed on J12).

8. I have configured a Port pin as an analog input. Why is it still shorted to ground?

On C8051F91x-C8051F90x devices, configuring a Port pin to analog mode (using PnMDIN) disables the digital input path and the weak pull-up. It does not explicitly disable the output drivers.

Software can ensure that the output drivers are disabled by configuring the Port pin to open-drain output mode (using PnMDOUT) and writing 1 to the port latch.

9. Why does power consumption increase when an analog signal (hovering around mid-supply) is connected to a digital input?

This phenomenon is called the “crowbar” effect and is present in all CMOS circuitry. If the input of a CMOS structure is not a strong 1 or 0, then both the PMOS and NMOS devices are partially turned on causing current flow from VDD to GND.

To prevent the “crowbar” effect, ensure that pins with analog voltage levels are configured for analog I/O.

10. Why does the dc/dc converter stop regulating when the load current exceeds 10 mA?

The default register settings for the dc/dc converter are optimized for low power applications requiring less than 10 mA of supply current. If the application requires additional supply current, the default values may be overridden to provide up to 65 mW of output power.

To configure the dc/dc converter to high power mode, perform the following steps prior to enabling any high power device:

- a. Set DC0CN = 0x01. This selects the high-current switches.
- b. Set DC0CF = 0x04. This sets the peak inductor current limit to 500 mA.

11. When the missing clock detector is enabled, why does the MCU reset if I switch from the default system clock (Low Power Oscillator divided by 8) to smaRTClock divided by 1?

Background:

- The missing clock detector will trigger a reset if the system clock period exceeds 100 μ s.
- Switchover between clock sources occurs in 1 clock cycle of the slowest clock.
- Changing the clock divide value requires up to 128 cycles of the undivided clock source.

Since the **clock source** change occurs in a single cycle and the **clock divide** change can take up to 128 cycles, the system clock will be set to the **new clock source divided by the old divide value** for a brief period of time. In this example, the actual system clock will be 4.096 kHz for up to 128 cycles of the undivided clock source. This causes the missing clock detector to time out and reset the MCU.

The proper way of changing the system clock when both the **clock source** and the **clock divide** value are being changed is as follows:

If switching from a fast “undivided” clock to a slower “undivided” clock:

- a. Change the **clock divide** value.
- b. Poll for $CLKRDY \geq 1$.
- c. Change the **clock source**.

If switching from a fast “undivided” clock to a slower “undivided” clock:

- d. Change the **clock source**.
- e. Change the **clock divide** value.
- f. Poll for $CLKRDY \geq 1$.

12. Why is the MCU pre-maturely released from reset when using a wall supply with a slow rise time?

The maximum VDD Ramp Time is specified at 3 ms. If the power supply ramp takes longer than 3 ms to reach 0.9 V, then the device may be released from reset before the supply has reached the minimum operating voltage. The slow ramp time (>3 ms) can occur when using a bench power supply that does not have an output enable switch.

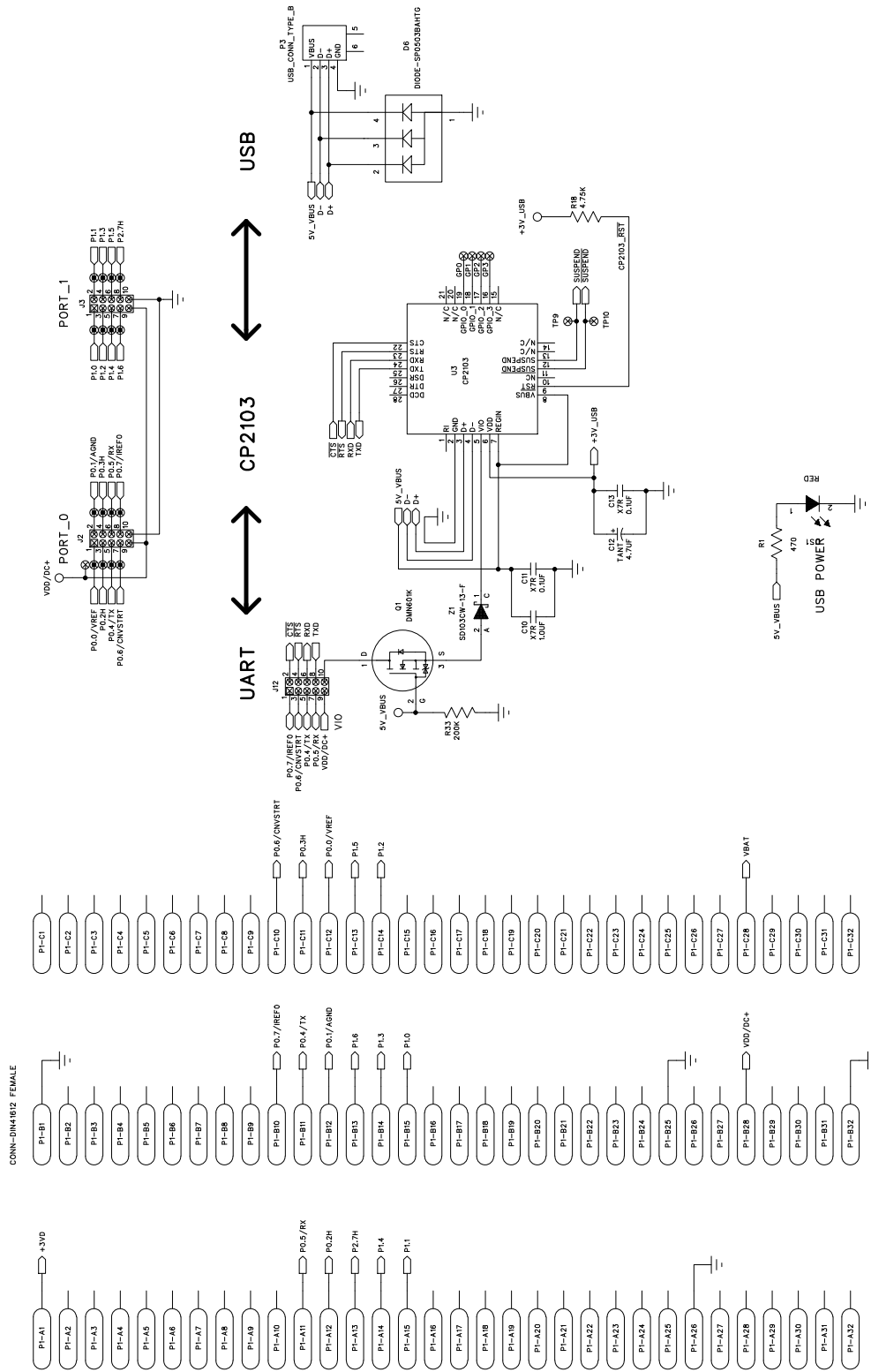

Figure 11. C8051F912 Target Board Schematic (Page 2 of 3)

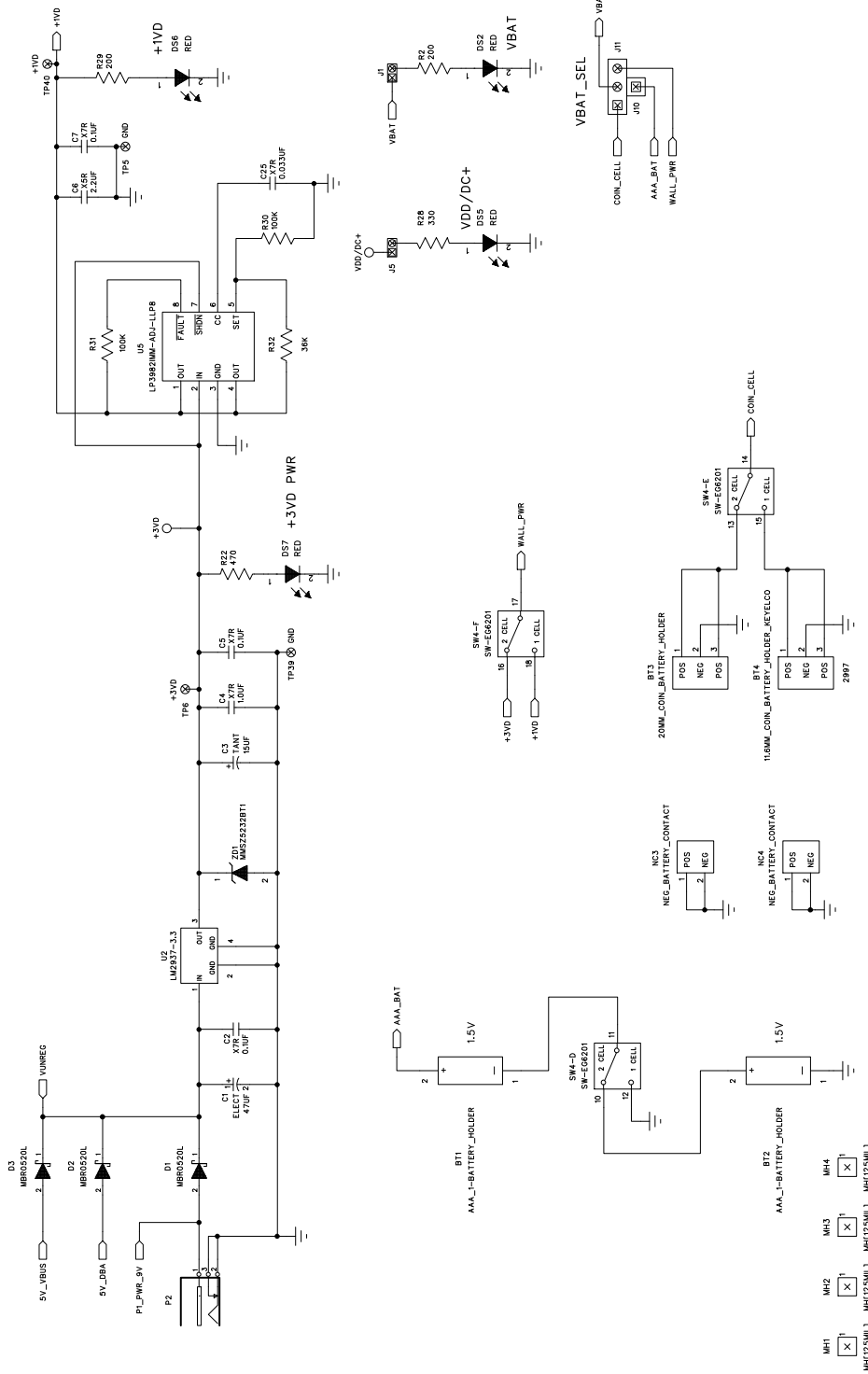

Figure 12. C8051F912 Target Board Schematic (Page 3 of 3)

NOTES:

CONTACT INFORMATION

Silicon Laboratories Inc.
400 West Cesar Chavez
Austin, TX 78701

Please visit the Silicon Labs Technical Support web page:
<https://www.silabs.com/support/pages/contacttechnicalsupport.aspx>
and register to submit a technical support request.

The information in this document is believed to be accurate in all respects at the time of publication but is subject to change without notice. Silicon Laboratories assumes no responsibility for errors and omissions, and disclaims responsibility for any consequences resulting from the use of information included herein. Additionally, Silicon Laboratories assumes no responsibility for the functioning of undescribed features or parameters. Silicon Laboratories reserves the right to make changes without further notice. Silicon Laboratories makes no warranty, representation or guarantee regarding the suitability of its products for any particular purpose, nor does Silicon Laboratories assume any liability arising out of the application or use of any product or circuit, and specifically disclaims any and all liability, including without limitation consequential or incidental damages. Silicon Laboratories products are not designed, intended, or authorized for use in applications intended to support or sustain life, or for any other application in which the failure of the Silicon Laboratories product could create a situation where personal injury or death may occur. Should Buyer purchase or use Silicon Laboratories products for any such unintended or unauthorized application, Buyer shall indemnify and hold Silicon Laboratories harmless against all claims and damages.

Silicon Laboratories and Silicon Labs are trademarks of Silicon Laboratories Inc.

Other products or brandnames mentioned herein are trademarks or registered trademarks of their respective holders.



Стандарт Электрон Связь

Мы молодая и активно развивающаяся компания в области поставок электронных компонентов. Мы поставляем электронные компоненты отечественного и импортного производства напрямую от производителей и с крупнейших складов мира.

Благодаря сотрудничеству с мировыми поставщиками мы осуществляем комплексные и плановые поставки широчайшего спектра электронных компонентов.

Собственная эффективная логистика и склад в обеспечивает надежную поставку продукции в точно указанные сроки по всей России.

Мы осуществляем техническую поддержку нашим клиентам и предпродажную проверку качества продукции. На все поставляемые продукты мы предоставляем гарантию .

Осуществляем поставки продукции под контролем ВП МО РФ на предприятия военно-промышленного комплекса России , а также работаем в рамках 275 ФЗ с открытием отдельных счетов в уполномоченном банке. Система менеджмента качества компании соответствует требованиям ГОСТ ISO 9001.

Минимальные сроки поставки, гибкие цены, неограниченный ассортимент и индивидуальный подход к клиентам являются основой для выстраивания долгосрочного и эффективного сотрудничества с предприятиями радиоэлектронной промышленности, предприятиями ВПК и научно-исследовательскими институтами России.

С нами вы становитесь еще успешнее!

Наши контакты:

Телефон: +7 812 627 14 35

Электронная почта: sales@st-electron.ru

Адрес: 198099, Санкт-Петербург,
Промышленная ул, дом № 19, литера Н,
помещение 100-Н Офис 331