Li-ION/POLYMER 2-CELL PROTECTOR

NO.EA-165-190704

OUTLINE

The R5460x2xxxx Series are high voltage CMOS-based protection ICs for over-charge/discharge of rechargeable two-cell Lithium-ion (Li+) / Lithium polymer, further include a short circuit protection circuit for preventing large external short circuit current and the protection circuits against the excess discharge-current and excess charge current.

Each of these ICs is composed of six voltage detectors, a reference unit, a delay circuit, a short circuit protector, an oscillator, a counter, and a logic circuit. When the over-charge voltage threshold or excess-charge current threshold crosses the each detector threshold from a low value to a high value, the output of C_{OUT} pin switches to "L" level after internal fixed delay time. To release over-charge detector after detecting over-charge, the detector can be reset and the output of C_{OUT} becomes "H" when a kind of load is connected to V_{DD} after a charger is disconnected from the battery pack and the cell voltage becomes lower than over-charge detector threshold. In case that a charger is continuously connected to the battery pack, if the cell voltage becomes lower than the over-charge released voltage, over-charge state is also released.

The output of D_{OUT} pin, the output of the over-discharge detector and the excess discharge-current detector, switches to "L" level after internally fixed delay time, when discharged voltage crosses the detector threshold from a high value to a value lower than V_{DET2}.

The conditions to release over-discharge voltage detector after detecting over-discharge voltage are as follows:

A/D versions: after connecting a charger, when the cell voltage becomes higher than over-discharge detector threshold or, without connecting charger, when the cell voltage becomes equal or higher than over-discharge released voltage.

C version: after connecting a charger, when the cell voltage becomes higher than over-discharge detector threshold voltage.

E version: whether connecting a charger, or not, when the cell voltage becomes higher than released voltage from over-discharge.

F version: after connecting a charger, when the cell voltage becomes higher than released voltage from over-discharge.

In case that connecting a charger, for A/C/D versions, there is no hysteresis for over-discharge detector. E/F versions, even if a charger is connected to the battery pack, the hysteresis of over-discharge detector exists.

To satisfy the release conditions for over-discharge voltage protector, the output voltage of D_{OUT} becomes "H".

Even if a battery is discharged to 0V, charge current is acceptable.

After detecting excess-discharge current or short current, when the load is disconnected, the excess discharged or short condition is released and D_{OUT} becomes "H".

After detecting over-discharge voltage, supply current will be kept extremely low by halting internal circuits' operation.

When the output of C_{OUT} is "H", if V- pin level is set at -1.6V, the delay time of over-charge and over-discharge detector can be shortened. Especially, the delay time of the over-charge detector can be reduced into approximately 1/60 and test time for protection circuit PCB can be reduced. The output type of C_{OUT} and D_{OUT} is CMOS.

R5460x2xx

NO.EA-165-190704

FEATURES

- Manufactured with High Voltage Tolerant Process.....Absolute Maximum Rating 30V
- Low supply current.....Supply current (At normal mode) Typ. 4.0μA
 - Standby current Typ. 1.2μA (A/ D/ E version)
 - Max. 0.1μA (C/ F version)
- High accuracy detector threshold.....Over-charge detector (Ta=25°C) ±25mV
 - (Ta=-5 to 55°C) ±30mV
 - Over-discharge detector ±2.5%
 - Excess discharge-current detector ±15mV
 - Excess charge-current detector ±40mV
- Variety of detector threshold
 - Over-charge detector threshold (A/C/E/F version) 4.1V-4.5V step of 0.005V (VD1U/VD1L)
 - Over-charge detector threshold (D version) 3.5V-4.0V step of 0.005V (VD1U/VD1L)
 - Over-discharge detector threshold 2.0V-3.0V step of 0.005V (VD2U/VD2L)
 - Excess discharge-current threshold 0.05V-0.20V step of 0.005V
 - 3 options of Excess charge-current threshold
 - (1) -0.4V ±40mV
 - (2) -0.2V ±30mV
 - (3) -0.1V ±30mV
 - Over-charge released voltage 0.1V-0.4V step of 0.05V (VH1U/VH1L)
 - Over-discharge released voltage 0.2V-0.7V step of 0.1V (VH2U/VH2L)
- Internal fixed Output delay timeOver-charge detector Output Delay 1.0s
 - Over-discharge detector Output Delay 128ms
 - Excess discharge-current detector Output Delay 12ms
 - Excess charge-current detector Output Delay 8ms
 - Short Circuit detector Output Delay 300μs
- Output Delay Time Shortening Function.....At C_{OUT} is "H", if V- level is set at -1.6V, the Output Delay time of detect the over-charge and over-discharge can be reduced. (Delay Time for over-charge becomes about 1/60 of normal state.)
- 0V-battery charge.....acceptable
- Ultra Small packageSOT-23-6, DFN(PLP)1820-6

APPLICATIONS

- Li+ / Li Polymer protector of over-charge, over-discharge, excess-current for battery pack
- High precision protectors for cell-phones and any other gadgets using on board Li+ / Li Polymer battery

BLOCK DIAGRAMS

A/D/E/F version

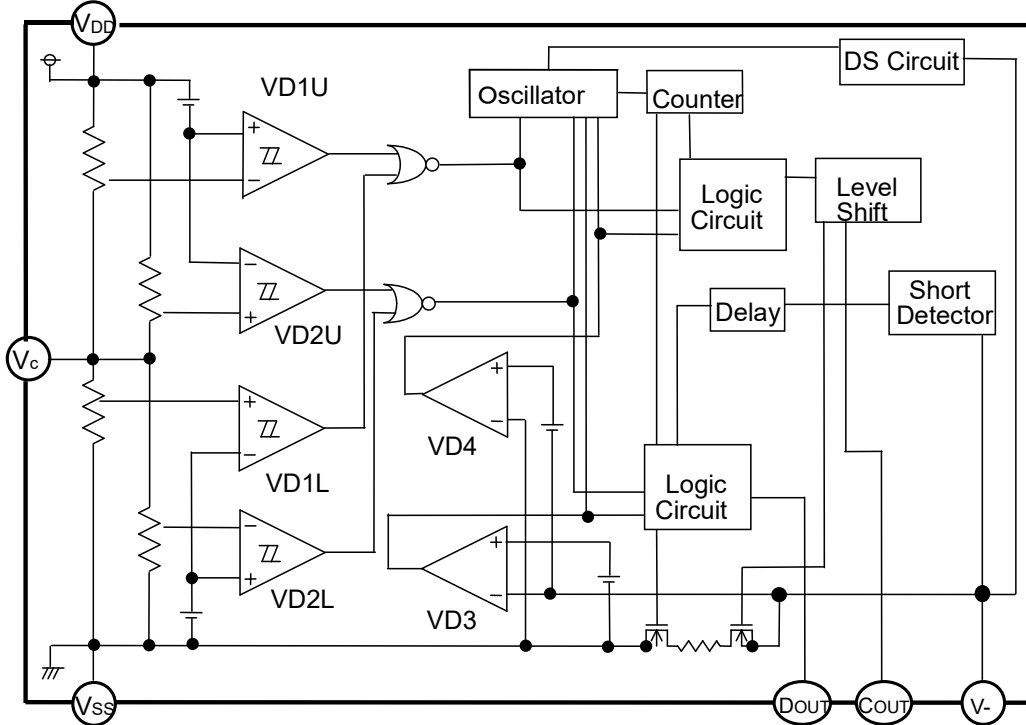

C version

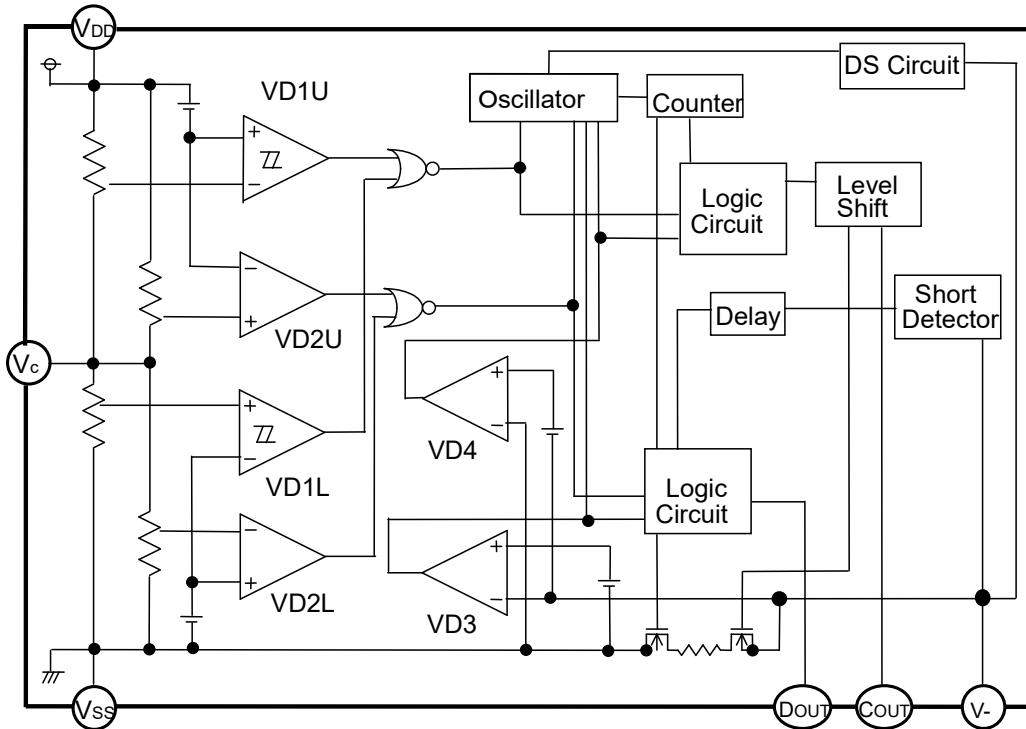

R5460x2xx

NO.EA-165-190704

SELECTION GUIDE

In the R5460x2xxxx Series, input threshold of over-charge, over-discharge, excess discharge current, and the package and taping can be designated.

Part Number is designated as follows:

R5460x2xxxx-xx ←Part Number
↑↑↑↑↑
a b c d e

Code	Contents
a	Package Type N: SOT-23-6 K: DFN(PLP)1820-6
b	Serial Number for the R5460 Series designating input threshold for over-charge, over-discharge, excess discharge-current detectors.
c	Designation of Output delay option of over-charge and excess discharge-current.
d	Designation of version symbols.
e	Taping Type: TR (refer to Taping Specification)

PIN CONFIGURATIONS

SOT-23-6

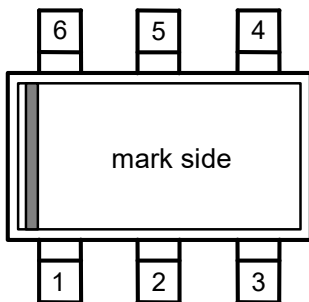

DFN(PLP)1820-6

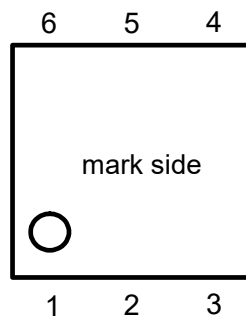

PIN DESCRIPTION

Pin No.		Symbol	Description
SOT-23-6	PLP1820-6		
1	3	D _{OUT}	Output pin of over-discharge detection, CMOS output
2	1	C _{OUT}	Output pin of over-charge detection, CMOS output
3	2	V-	Charger negative Input Pin
4	6	VC	Input Pin of the center voltage between two-cell
5	5	V _{DD}	Power supply pin, the substrate voltage level of the IC.
6	4	V _{SS}	V _{SS} pin. Ground pin for the IC

The backside tab of DFN(PLP)1820-6 package is connected to the substrate level. (V_{DD}) Note that avoiding short with other level.

ABSOLUTE MAXIMUM RATINGS

T_a=25°C, V_{SS}=0V

Item	Symbol	Ratings	Unit
Supply Voltage	V _{DD}	-0.3 to 12	V
Input Voltage			
Middle pin Voltage between 2-cell	V _C	V _{SS} -0.3 to V _{DD} +0.3	V
V- pin Voltage	V-	V _{DD} -30 to V _{DD} +0.3	V
Output Voltage			
C _{OUT} pin Voltage	V _{COUT}	V _{DD} -30 to V _{DD} +0.3	V
D _{OUT} pin Voltage	V _{DOUT}	V _{SS} -0.3 to V _{DD} +0.3	V
Power Dissipation	P _D	150	mW
Operating Temperature	T _a	-40 to 85	°C
Storage Temperature	T _{stg}	-55 to 125	°C

*Note: Exposure to the condition exceeded Absolute Maximum Ratings may cause permanent damage and affects the reliability and safety of both device and systems using the device. The functional operations cannot be guaranteed beyond specified values in the recommended conditions.

R5460x2xx

NO.EA-165-190704

ELECTRICAL CHARACTERISTICS

R5460x2xxAA/AD/AE version

Unless otherwise specified, Ta=25°C

Symbol	Item	Conditions	Min.	Typ.	Max.	Unit
V _{DD1}	Operating input voltage	Voltage defined as V _{DD} -V _{SS}	1.5		10.0	V
V _{st}	Minimum operating Voltage for 0V charging	Voltage defined as V _{DD} -V _{DD} -V _{SS} =0V			1.8	V
V _{DET1U}	CELL1 Over-charge threshold	Detect rising edge of supply voltage R1=330Ω R1=330Ω (Ta=-5 to 55°C)*Note	V _{DET1U} -0.025 V _{DET1U} -0.030	V _{DET1U} V _{DET1U}	V _{DET1U} +0.025 V _{DET1U} +0.030	V V
V _{REL1U}	CELL1 Over-charge released voltage	R1=330Ω	V _{REL1U} -0.05	V _{REL1U}	V _{REL1U} +0.05	V
t _{VDET1}	Output delay of over-charge	V _{DD} =3.2V to 4.5V, V _C -V _{SS} =3.2V	0.7	1.0	1.3	s
t _{VREL1}	Output delay of release from over-charge	V _{DD} =4.5V to 3.2V, V _C -V _{SS} =3.2V	11	16	21	ms
V _{DET1L}	CELL2 Over-charge detector threshold	Detect rising edge of supply voltage R2=330Ω R2=330Ω (Ta=-5 to 55°C)*Note	V _{DET1L} -0.025 V _{DET1L} -0.030	V _{DET1L} V _{DET1L}	V _{DET1L} +0.025 V _{DET1L} +0.030	V V
V _{REL1L}	CELL2 Over-charge released voltage	R2=330Ω	V _{REL1L} -0.05	V _{REL1L}	V _{REL1L} +0.05	V
V _{DET2U}	CELL1 Over-discharge threshold	Detect falling edge of supply voltage	V _{DET2U} ×0.975	V _{DET2U}	V _{DET2U} ×1.025	V
V _{REL2U}	CELL1 Released Voltage from Over-discharge	Detect rising edge of supply voltage	V _{REL2U} ×0.975	V _{REL2U}	V _{REL2U} ×1.025	V
t _{VDET2}	Output delay of over-discharge	V _{DD} -V _C =3.2V to 1.9V V _C -V _{SS} =3.2V	89	128	167	ms
t _{VREL2}	Output delay of release from over-discharge	V _{DD} -V _C =1.9V to 3.2V, V _C -V _{SS} =3.2V	0.7	1.2	1.7	ms
V _{DET2L}	CELL2 Over-discharge threshold	Detect falling edge of supply voltage	V _{DET2L} ×0.975	V _{DET2L}	V _{DET2L} ×1.025	V
V _{REL2L}	CELL2 Released Voltage from Over-discharge	Detect rising edge of supply voltage	V _{REL2L} ×0.975	V _{REL2L}	V _{REL2L} ×1.025	V
V _{DET3}	Excess discharge-current threshold	Detect rising edge of 'V-' pin voltage	V _{DET3} -0.015	V _{DET3}	V _{DET3} +0.015	V
t _{VDET3}	Output delay of excess discharge current	V _{DD} -V _C =V _C -V _{SS} =3.2V, V ₋ =0V to 0.5V	8	12	16	ms
t _{VREL3}	Output delay of release from excess discharge-current	V _{DD} -V _C =V _C -V _{SS} =3.2V, V ₋ =3V to 0V	0.7	1.2	1.7	ms
V _{DET4}	Excess charge-current threshold	Detect falling edge of 'V-' pin voltage	-0.44 -0.23 -0.13	-0.40 -0.20 -0.10	-0.36 -0.17 -0.07	V
t _{VDET4}	Output delay of excess charge-current	V _{DD} -V _C =V _C -V _{SS} =3.2V, V ₋ =0V to -1V	5	8	11	ms
t _{VREL4}	Output delay of release from excess charge-current	V _{DD} -V _C =V _C -V _{SS} =3.2V, V ₋ =-1V to 0V	0.7	1.2	1.7	ms
V _{short}	Short protection voltage	V _{DD} -V _C =V _C -V _{SS} =3.2V	0.7	1.1	1.5	V
t _{short}	Output Delay of Short protection	V _{DD} -V _C =V _C -V _{SS} =3.2V, V ₋ =0V to 6.4V	150	300	500	μs
R _{short}	Reset resistance for Excess discharge-current protection	V _{DD} -V _C =V _C -V _{SS} =3.2V, V ₋ =1V	25	40	75	kΩ
V _{Ds}	Delay Shortening Mode input voltage	V _{DD} -V _C =V _C -V _{SS} =4.0V	-2.2	-1.6	-1.0	V
V _{OL1}	Nch ON voltage of C _{OUT}	I _{OL} =50μA, V _{DD} -V _C =V _C -V _{SS} =4.5V		0.4	0.5	V
V _{OH1}	Pch ON voltage of C _{OUT}	I _{OH} =-50μA, V _{DD} -V _C =V _C -V _{SS} =3.2V	6.8	7.4		V
V _{OL2}	Nch ON voltage of D _{OUT}	I _{OL} =50μA, V _{DD} -V _C =V _C -V _{SS} =1.9V		0.2	0.5	V
V _{OH2}	Pch ON voltage of D _{OUT}	I _{OH} =-50μA, V _{DD} -V _C =V _C -V _{SS} =3.2V	6.8	7.4		V
I _{DD}	Supply current	V _{DD} -V _C =V _C -V _{SS} =3.2V, V ₋ =0V		4.0	8.0	μA
I _s	Standby current	V _{DD} -V _C =V _C -V _{SS} =1.9V		1.2	2.0	μA

*Note: We compensate for this characteristic related to temperature by laser-trim, however, this specification is guaranteed by design, not production tested.

R5460x2xxAC version

Unless otherwise specified, Ta=25°C

Symbol	Item	Conditions	Min.	Typ.	Max.	Unit
V _{DD1}	Operating input voltage	Voltage defined as V _{DD} -V _{SS}	1.50		10.0	V
V _{st}	Minimum operating Voltage for 0V charging	Voltage defined as V _{DD} -V _{DD} -V _{SS} =0V			1.8	V
V _{DET1U}	CELL1 Over-charge threshold	Detect rising edge of supply voltage R1=330Ω R1=330Ω (Ta=-5 to 55°C)*Note	V _{DET1U} -0.025 V _{DET1U} -0.030	V _{DET1U} V _{DET1U}	V _{DET1U} +0.025 V _{DET1U} +0.030	V V
V _{REL1U}	CELL1 Over-charge released voltage	R1=330Ω	V _{REL1U} -0.05	V _{REL1U}	V _{REL1U} +0.05	V
t _{VDET1}	Output delay of over-charge	V _{DD} =3.2V to 4.5V, V _C -V _{SS} =3.2V	0.7	1.0	1.3	s
t _{VREL1}	Output delay of release from over-charge	V _{DD} =4.5V to 3.2V, V _C -V _{SS} =3.2V	11	16	21	ms
V _{DET1L}	CELL2 Over-charge detector threshold	Detect rising edge of supply voltage R2=330Ω R2=330Ω (Ta=-5 to 5°C)*Note	V _{DET1L} -0.025 V _{DET1L} -0.030	V _{DET1L} V _{DET1L}	V _{DET1L} +0.025 V _{DET1L} +0.030	V V
V _{REL1L}	CELL2 Over-charge released voltage	R2=330Ω	V _{REL1L} -0.050	V _{REL1L}	V _{REL1L} +0.050	V
V _{DET2U}	CELL1 Over-discharge threshold	Detect falling edge of supply voltage	V _{DET2U} ×0.975	V _{DET2U}	V _{DET2U} ×1.025	V
t _{VDET2}	Output delay of over-discharge	V _{DD} -V _C =3.2V to 1.9V V _C -V _{SS} =3.2V	89	128	167	ms
t _{VREL2}	Output delay of release from over-discharge	V _{DD} -V _C =1.9V to 3.2V V _C -V _{SS} =3.2V	0.7	1.2	1.7	ms
V _{DET2L}	CELL2 Over-discharge threshold	Detect falling edge of supply voltage	V _{DET2L} ×0.975	V _{DET2L}	V _{DET2L} ×1.025	V
V _{DET3}	Excess discharge-current threshold	Detect rising edge of 'V-' pin voltage	V _{DET3} -0.015	V _{DET3}	V _{DET3} +0.015	V
t _{VDET3}	Output delay of excess discharge current	V _{DD} -V _C =V _C -V _{SS} =3.2V, V ₋ =0V to 0.5V	8	12	16	ms
t _{VREL3}	Output delay of release from excess discharge-current	V _{DD} -V _C =V _C -V _{SS} =3.2V, V ₋ =3V to 0V	0.7	1.2	1.7	ms
V _{DET4}	Excess charge-current threshold	Detect falling edge of 'V-' pin voltage	-0.44 -0.23 -0.13	-0.40 -0.20 -0.10	-0.36 -0.17 -0.07	V
t _{VDET4}	Output delay of excess charge-current	V _{DD} -V _C =V _C -V _{SS} =3.2V, V ₋ =0V to -1V	5	8	11	ms
t _{VREL4}	Output delay of release from excess charge-current	V _{DD} -V _C =V _C -V _{SS} =3.2V, V ₋ =-1V to 0V	0.7	1.2	1.7	ms
V _{short}	Short protection voltage	V _{DD} -V _C =V _C -V _{SS} =3.2V	0.7	1.1	1.5	V
t _{short}	Output Delay of Short protection	V _{DD} -V _C =V _C -V _{SS} =3.2V, V ₋ =0V to 6.4V	150	300	500	μs
R _{short}	Reset resistance for Excess discharge-current protection	V _{DD} -V _{CC} =V _C -V _{SS} =3.2V, V ₋ =1V	25	40	75	kΩ
V _{Ds}	Delay Shortening Mode input voltage	V _{DD} -V _C =V _C -V _{SS} =4.0V	-2.2	-1.6	-1.0	V
V _{OL1}	Nch ON voltage of C _{OUT}	I _{OL} =50μA V _{DD} -V _C =V _C -V _{SS} =4.5V		0.4	0.5	V
V _{OH1}	Pch ON voltage of C _{OUT}	I _{OH} =-50μA V _{DD} -V _C =V _C -V _{SS} =3.2V	6.8	7.4		V
V _{OL2}	Nch ON voltage of D _{OUT}	I _{OL} =50μA V _{DD} -V _C =V _C -V _{SS} =1.9V		0.2	0.5	V
V _{OH2}	Pch ON voltage of D _{OUT}	I _{OH} =-50μA, V _{DD} -V _C =V _C -V _{SS} =3.2V	6.8	7.4		V
I _{DD}	Supply current	V _{DD} -V _C =V _C -V _{SS} =3.2V, V ₋ =0V		4.0	8.0	μA
I _s	Standby current	V _{DD} -V _C =V _C -V _{SS} =1.9V			0.1	μA

*Note: We compensate for this characteristic related to temperature by laser-trim, however, this specification is guaranteed by design, not production tested.

R5460x2xx

NO.EA-165-190704

R5460x2xxAF version

Unless otherwise specified, Ta=25°C

Symbol	Item	Conditions	Min.	Typ.	Max.	Unit
V _{DD1}	Operating input voltage	Voltage defined as V _{DD} -V _{SS}	1.5		10.0	V
V _{st}	Minimum operating Voltage for 0V charging	Voltage defined as V _{DD} -V _{DD} -V _{SS} =0V			1.8	V
V _{DET1U}	CELL1 Over-charge threshold	Detect rising edge of supply voltage R1=330Ω R1=330Ω (Ta=-5 to 55°C)*Note	V _{DET1U} -0.025 V _{DET1U} -0.030	V _{DET1U} V _{DET1U}	V _{DET1U} +0.025V V _{DET1U} +0.030	V V
V _{REL1U}	CELL1 Over-charge released voltage	R1=330Ω	V _{REL1U} -0.05	V _{REL1U}	V _{REL1U} +0.05	V
t _{VDET1}	Output delay of over-charge	V _{DD} =3.2V to 4.5V, V _C -V _{SS} =3.2V	0.7	1.0	1.3	s
t _{VREL1}	Output delay of release from over-charge	V _{DD} =4.5V to 3.2V, V _C -V _{SS} =3.2V	11	16	21	ms
V _{DET1L}	CELL2 Over-charge detector threshold	Detect rising edge of supply voltage R2=330Ω R2=330Ω (Ta=-5 to 55°C)*Note	V _{DET1L} -0.025 V _{DET1L} -0.030	V _{DET1L} V _{DET1L}	V _{DET1L} +0.025 V _{DET1L} +0.030	V V
V _{REL1L}	CELL2 Over-charge released voltage	R2=330Ω	V _{REL1L} -0.050	V _{REL1L}	V _{REL1L} +0.050	V
V _{DET2U}	CELL1 Over-discharge threshold	Detect falling edge of supply voltage	V _{DET2U} ×0.975	V _{DET2U}	V _{DET2U} ×1.025	V
V _{REL2U}	CELL1 Released Voltage from Over-discharge	Detect rising edge of supply voltage	V _{REL2U} ×0.975	V _{REL2U}	V _{REL2U} ×1.025	V
t _{VDET2}	Output delay of over-discharge	V _{DD} -V _C =3.2V to 1.9V V _C -V _{SS} =3.2V	89	128	167	ms
t _{VREL2}	Output delay of release from over-discharge	V _{DD} -V _C =1.9V to 3.2V V _C -V _{SS} =3.2V	0.7	1.2	1.7	ms
V _{DET2L}	CELL2 Over-discharge threshold	Detect falling edge of supply voltage	V _{DET2L} ×0.975	V _{DET2L}	V _{DET2L} ×1.025	V
V _{REL2L}	CELL2 Released Voltage from Over-discharge	Detect rising edge of supply voltage	V _{REL2L} ×0.975	V _{REL2L}	V _{REL2L} ×1.025	V
V _{DET3}	Excess discharge-current threshold	Detect rising edge of 'V-' pin voltage	V _{DET3} -0.015	V _{DET3}	V _{DET3} +0.015	V
t _{VDET3}	Output delay of excess discharge current	V _{DD} -V _C =V _C -V _{SS} =3.2V, V ₋ =0V to 0.5V	8	12	16	ms
t _{VREL3}	Output delay of release from excess discharge-current	V _{DD} -V _C =V _C -V _{SS} =3.2V, V ₋ =3V to 0V	0.7	1.2	1.7	ms
V _{DET4}	Excess charge-current threshold	Detect falling edge of 'V-' pin voltage	-0.44 -0.23 -0.13	-0.40 -0.20 -0.10	-0.36 -0.17 -0.07	V
t _{VDET4}	Output delay of excess charge-current	V _{DD} -V _C =V _C -V _{SS} =3.2V, V ₋ =0V to -1V	5	8	11	ms
t _{VREL4}	Output delay of release from excess charge-current	V _{DD} -V _C =V _C -V _{SS} =3.2V, V ₋ =-1V to 0V	0.7	1.2	1.7	ms
V _{short}	Short protection voltage	V _{DD} -V _C =V _C -V _{SS} =3.2V	0.7	1.1	1.5	V
t _{short}	Output Delay of Short protection	V _{DD} -V _C =V _C -V _{SS} =3.2V, V ₋ =0V to 6.4V	150	300	500	μs
R _{short}	Reset resistance for Excess discharge-current protection	V _{DD} -V _C =V _C -V _{SS} =3.2V, V ₋ =1V	25	40	75	kΩ
V _{DS}	Delay Shortening Mode input voltage	V _{DD} -V _C =V _C -V _{SS} =4.0V	-2.2	-1.6	-1.0	V
V _{OL1}	Nch ON voltage of C _{OUT}	I _{OL} =50μA V _{DD} -V _C =V _C -V _{SS} =4.5V		0.4	0.5	V
V _{OH1}	Pch ON voltage of C _{OUT}	I _{OH} =-50μA V _{DD} -V _C =V _C -V _{SS} =3.2V	6.8	7.4		V
V _{OL2}	Nch ON voltage of D _{OUT}	I _{OL} =50μA V _{DD} -V _C =V _C -V _{SS} =1.9V		0.2	0.5	V
V _{OH2}	Pch ON voltage of D _{OUT}	I _{OH} =-50μA, V _{DD} -V _C =V _C -V _{SS} =3.2V	6.8	7.4		V
I _{DD}	Supply current	V _{DD} -V _C =V _C -V _{SS} =3.2V V ₋ =0V		4.0	8.0	μA
I _S	Standby current	V _{DD} -V _C =V _C -V _{SS} =1.9V			0.1	μA

*Note: We compensate for this characteristic related to temperature by laser-trim, however, this specification is guaranteed by design, not production tested.

OPERATION

● V_{DET1U}, V_{DET1L} / Over-Charge Detectors

The V_{DET1U} and V_{DET1L} monitor the voltage between V_{DD} pin and V_C pin (the voltage of Cell1) and the voltage between V_C pin and V_{SS} pin (the voltage of Cell2), if either voltage becomes equal or more than the over-charge detector threshold, the over-charge is detected, and an external charge control Nch MOSFET turns off with C_{OUT} pin being at "L" level.

V_{DET1U} is the detector of Cell1, and the V_{DET1L} is the detector of Cell2.

To reset the over-charge and make the C_{OUT} pin level to "H" again after detecting over-charge, in such conditions that a time when the both Cell1 and Cell2 are down to a level lower than over-charge voltage, by connecting a kind of load to V_{DD} after disconnecting a charger from the battery pack. Then, the output voltage of C_{OUT} pin becomes "H" and it makes an external Nch MOSFET turn on, and charge cycle is available. In case of the charger is continuously connected and over-charge is detected, both battery voltages of Cell1 and Cell2 become lower than the released voltage from over-charge, charge becomes possible. Therefore there is a specific hysteresis for over-charge detectors. To judge whether or not load is connected, the built-in excess-discharge current detector is used. By connecting some load, V₋ pin voltage becomes equal or more than excess-discharge current detector threshold, and reset the over-charge detecting state.

Further, either or both voltage of Cell1 and Cell2 is higher than the over-charge detector threshold, if a charger is removed and some load is connected, C_{OUT} outputs "L", however, load current can flow through the parasitic diode of the external charge control Nch MOSFET. After that, when both voltages of Cell1 and Cell2 become lower than the over-charge detector threshold, C_{OUT} becomes "H".

Internal fixed output delay times for over-charge detection and release from over-charge exist. If either or both of the voltage of Cell1 or Cell2 keeps its level more than the over-charge detector threshold, and output delay time passes, over-charge voltage is detected. Even when the voltage of Cell1 or Cell2 pin level becomes equal or higher level than V_{DET1} if these voltages would be back to a level lower than the over-charge detector threshold within a time period of the output delay time, the over-charge is not detected. Besides, after detecting over-charge, while the both of Cell1 and Cell2 voltages are lower than the over-charge detector threshold, even if a charger is removed and a load is connected, if the voltage is recovered within output delay time of release from over-charge, over-charge state is not released.

A level shifter incorporated in a buffer driver for the C_{OUT} pin makes the "L" level of C_{OUT} pin to the V₋ pin voltage and the "H" level of C_{OUT} pin is set to V_{DD} voltage with CMOS buffer.

● V_{DET2U}, V_{DET2L} / Over-Discharge Detectors

The V_{DET2U} and V_{DET2L} monitor the voltage between V_{DD} pin and V_C pin (Cell1 voltage) and the voltage between V_C pin and V_{SS} pin (Cell2 voltage). When either of the cell1 or cell2 voltage becomes equal or less than the over-discharge detector threshold, the over-discharge is detected and discharge stops by the external discharge control Nch MOSFET turning off with the D_{OUT} pin being at "L" level.

The conditions to release over-discharge voltage detector after detecting over-discharge voltage are as follows:

A/D versions: after connecting a charger, when the cell voltage becomes higher than over-discharge detector threshold or, without connecting charger, when the cell voltage becomes equal or higher than over-discharge released voltage.

C version: after connecting a charger, when the cell voltage becomes higher than over-discharge detector threshold voltage.

E version: whether connecting a charger, or not, when the cell voltage becomes higher than released voltage from over-discharge.

F version: after connecting a charger, when the cell voltage becomes higher than released voltage from over-discharge.

In case that connecting a charger, for A/C/D versions, there is no hysteresis for over-discharge detector. For E/F versions, even if a charger is connected to the battery pack, the hysteresis of over-discharge detector exists.

When a cell voltage equals to zero, if the voltage of a charger is equal or more than 0V-charge minimum voltage (V_{st}), C_{OUT} pin becomes "H" and a system is allowable to charge.

The output delay time for over-discharge detect is fixed internally. Even if either voltage of Cell1 or Cell2 is down to equal or lower than the over-discharge detector threshold, if the both voltages of Cell1 or Cell2 would be back to a level higher than the over-discharge detector threshold within a time period of the output delay time, the over-discharge is not detected. Output delay time for release from over-discharge is also set.

After detecting over-discharge, supply current would be reduced and be into standby by halting unnecessary circuits and

R5460x2xx

NO.EA-165-190704

consumption current of the IC itself is made as small as possible.

C/F version: after detecting over-discharge, all the circuits are halted and the R5460 will be into standby mode.

Others: after detecting over-discharge, whole circuits except over-discharge released detector function are halted, and the R5460 will be into standby mode.

The output type of D_{OUT} pin is CMOS having "H" level of V_{DD} and "L" level of V_{SS}.

● V_{DET3} /Excess discharge-current Detector, Short Circuit Protector

Both of the excess current detector and short circuit protection can work when the both of control FETs are in "ON" state.

When the V- pin voltage is up to a value between the short protection voltage (V_{short}) and excess discharge-current threshold V_{DET3}, V_{DET3} operates and further soaring of V- pin voltage higher than V_{short} makes the short circuit protector enabled. This leads the external discharge control Nch MOSFET turns off with the D_{OUT} pin being at "L" level.

An output delay time for the excess discharge-current detector is internally fixed.

A quick recovery of V- pin level from a value between V_{short} and V_{DET3} within the delay time keeps the discharge control FET staying "H" state. Output delay time for Release from excess discharge-current detection is also set.

When the short circuit protector is enabled, the D_{OUT} would be "L" and the delay time is also set.

The V- pin has a built-in pull-down resistor to the V_{SS} pin, that is, the resistance to release from excess-discharge current.

After an excess discharge-current or short circuit protection is detected, removing a cause of excess discharge-current or external short circuit makes an external discharge control FET to an "ON" state automatically with the V- pin level being down to the V_{SS} level through the built-in pulled down resistor. The reset resistor of excess discharge-current is off at normal state.

Only when detecting excess discharge-current or short circuit, the resistor is on.

Output delay time of excess discharge-current is set shorter than the delay time for over-discharge detector. Therefore, if V_{DD} voltage would be lower than V_{DET2} at the same time as the excess discharge-current is detected, the R5460x is at excess discharge-current detection mode. By disconnecting a load, V_{DET3} is automatically released from excess discharge-current.

● V_{DET4} / Excess charge-current detector

When the battery pack is chargeable and discharge is also possible, V_{DET4} senses V- pin voltage. For example, in case that a battery pack is charged by an inappropriate charger, an excess current flows, then the voltage of V- pin becomes equal or less than excess charge-current detector threshold. Then, the output of C_{OUT} becomes "L", and prevents from flowing excess current in the circuit by turning off the external Nch MOSFET.

Output delay of excess charge current is internally fixed. Even the voltage level of V- pin becomes equal or lower than the excess charge-current detector threshold, the voltage is higher than the V_{DET4} threshold within the delay time, the excess charge current is not detected. Output delay for the release from excess charge current is also set.

V_{DET4} can be released with disconnecting a charger and connecting a load.

● DS (Delay Shorten) function

Output delay time of over-charge, over-discharge can be shorter than those setting value by forcing equal or less than the delay shortening mode voltage to V- pin when the C_{OUT} is "H".

● Operation against 2-Cell Unbalance

A/D/E version: If one of the cells detects over-charge and the output of C_{OUT} becomes "L" and keeps the status, even if the other cell detects over-charge or over-discharge or short, the over-charge status is maintained and the output of C_{OUT} keeps "L". If one of the cell detects over-charge and the output of C_{OUT} becomes "L", the other cell detects over-discharge and the former cell is released from over-charge, after the delay time of the released from over-charge, the output of C_{OUT} becomes "H", and after the delay time of detecting over-discharge, the output of D_{OUT} becomes "L". After detecting over-discharge, A/D/E version halts internal unnecessary circuits and be into the standby mode. (Supply current Max. 2.0μA)

C/F version: If one of the cells detects over-charge, and when the C_{OUT} becomes "L", even if the other cell would detect over-discharge or short, the over-charge detector will be dominant and C_{OUT} keeps the "L" level. If one of the cell detects the over-discharge, and when the D_{OUT} becomes "L", in case that a charger is connected to the battery pack and the other cell detects over-charge, the internal counter will start and after the delay time of over-discharge detector, D_{OUT} will become "H". After the delay time of over-charge release from when the internal counter starts, C_{OUT} will be "L". If the over-discharge is detected, internal unnecessary circuits will be cut off and the standby mode will be realized. (Standby current Max. 0.1μA)

In any versions, the external FETs do not turn off at the same time.

TIMING CHART

(1) Timing diagram of Over-charge, Excess charge current

AA/AC/AD version

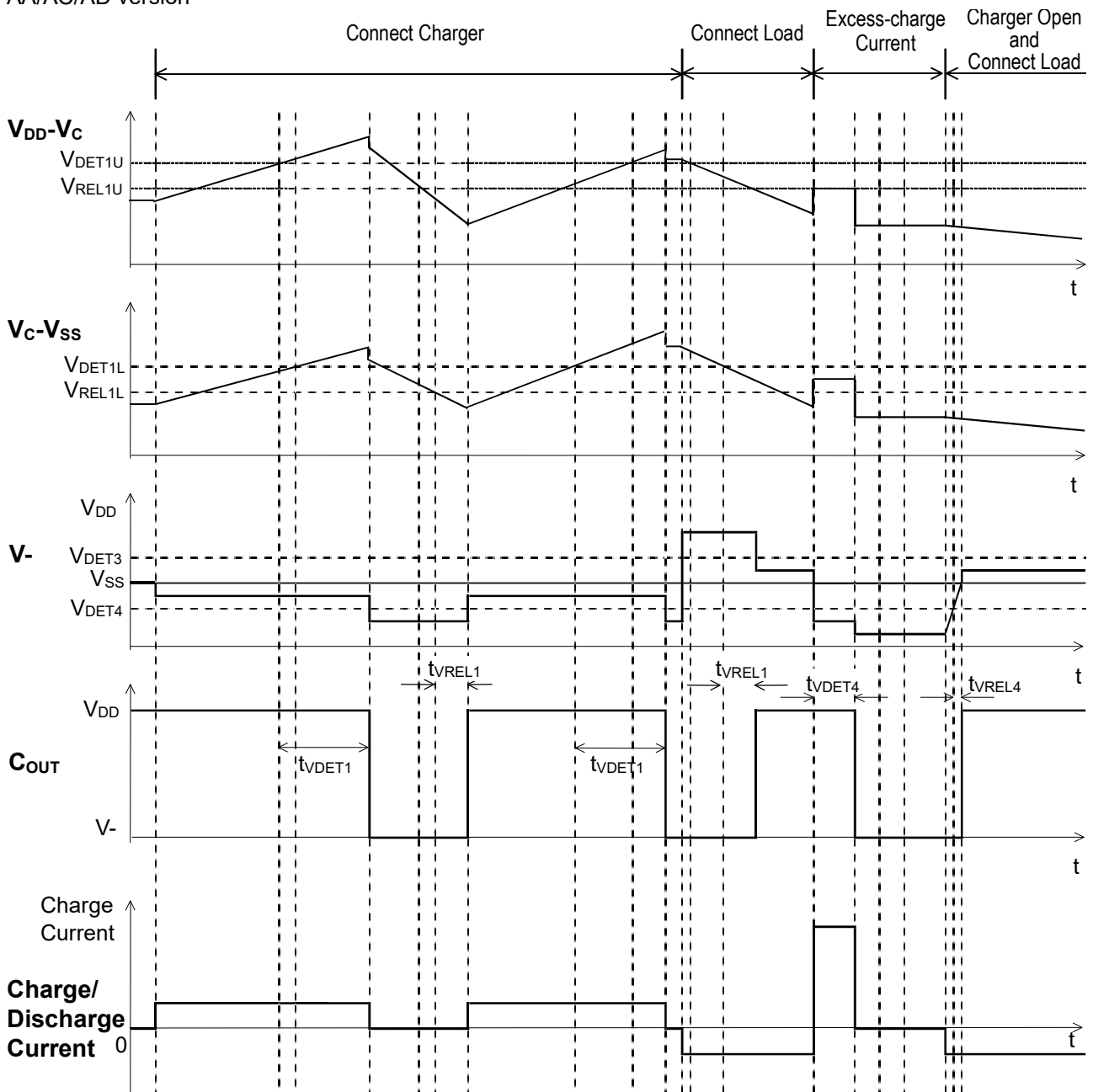

R5460x2xx

NO.EA-165-190704

AE / AF version

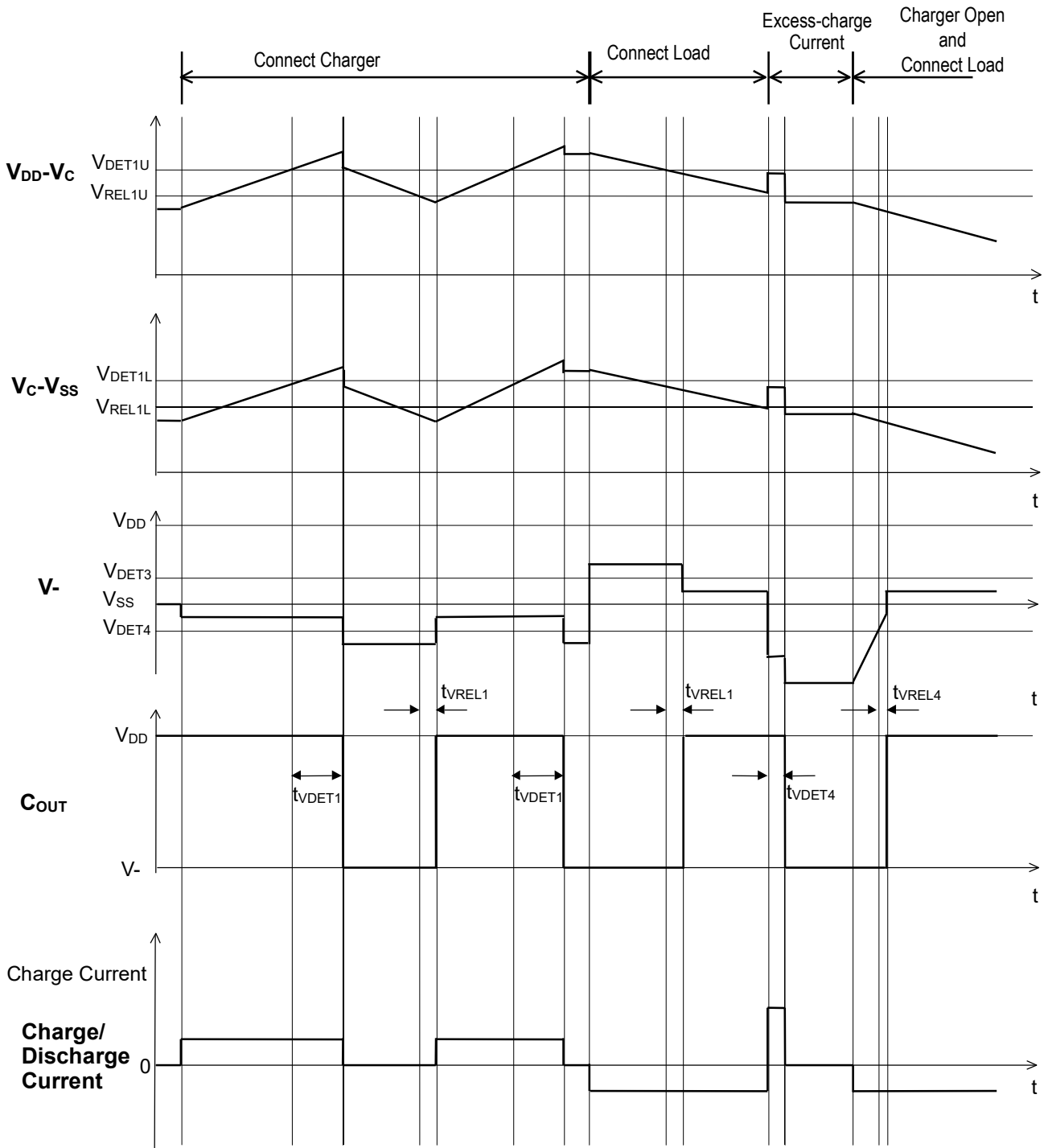

(2) Over-discharge, Excess discharge current, short circuit
AA/AD version

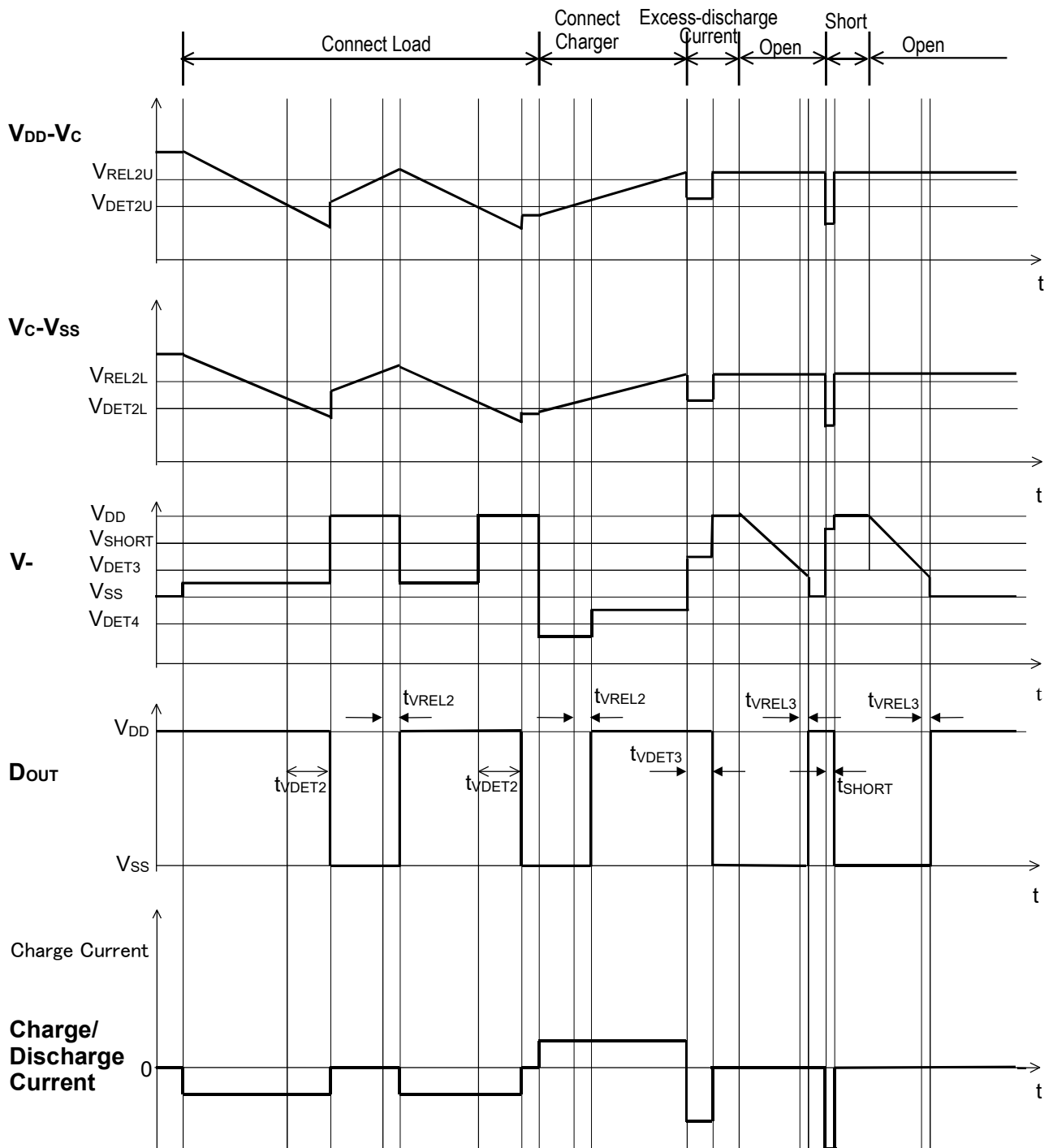

R5460x2xx

NO.EA-165-190704

AC version

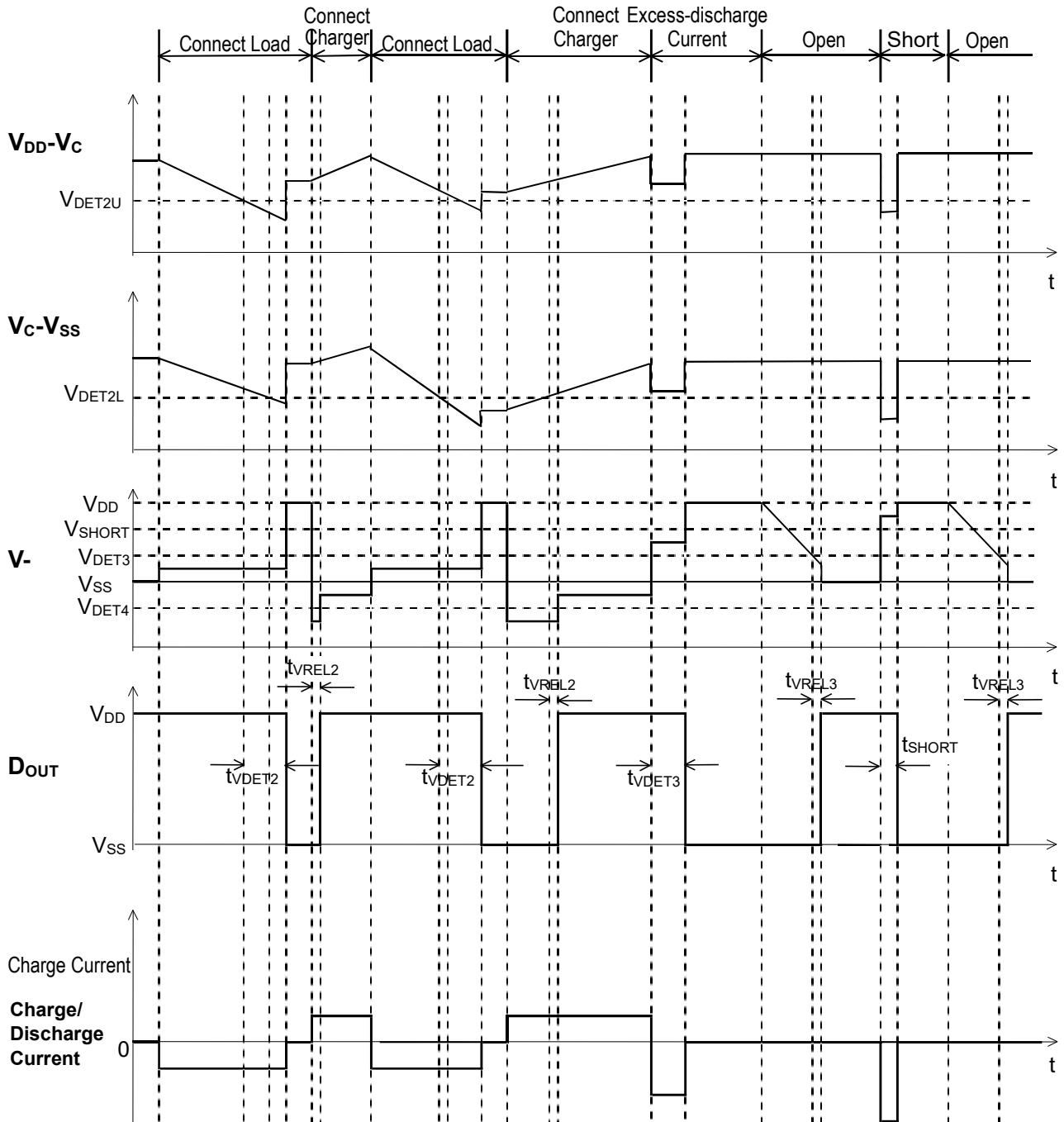

AE version

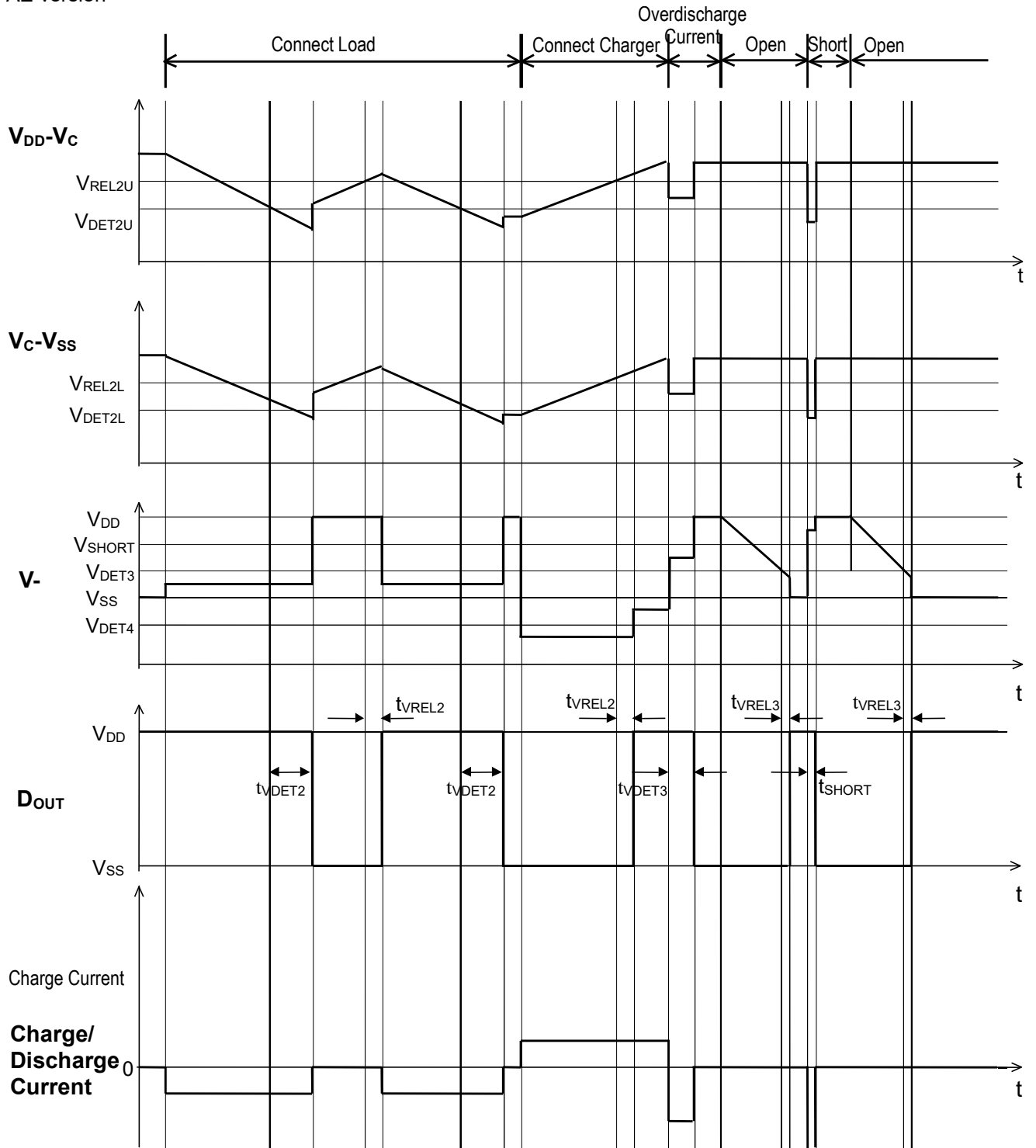

R5460x2xx

NO.EA-165-190704

AF version

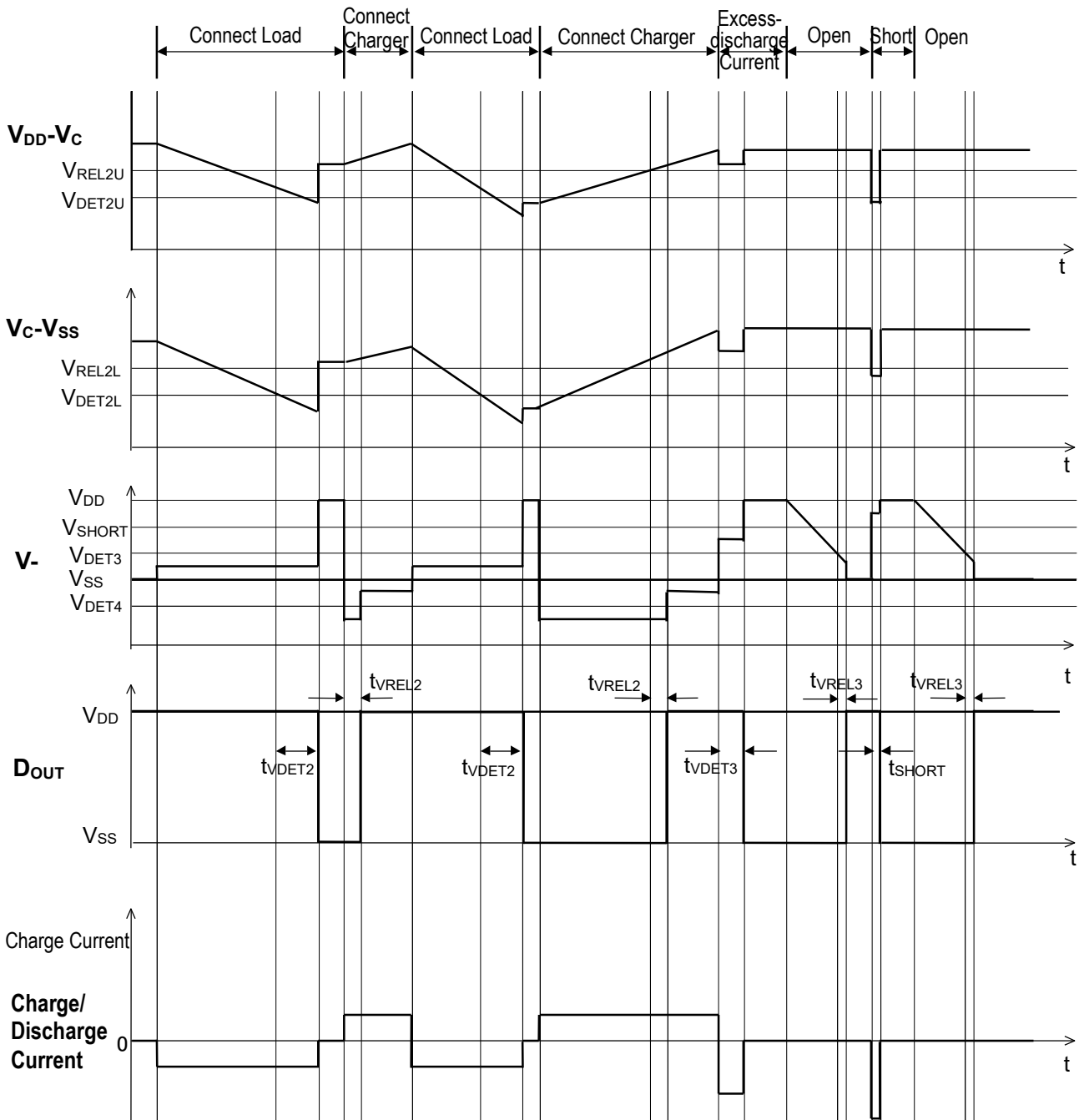

(3) Operation with unbalanced cells
AC version

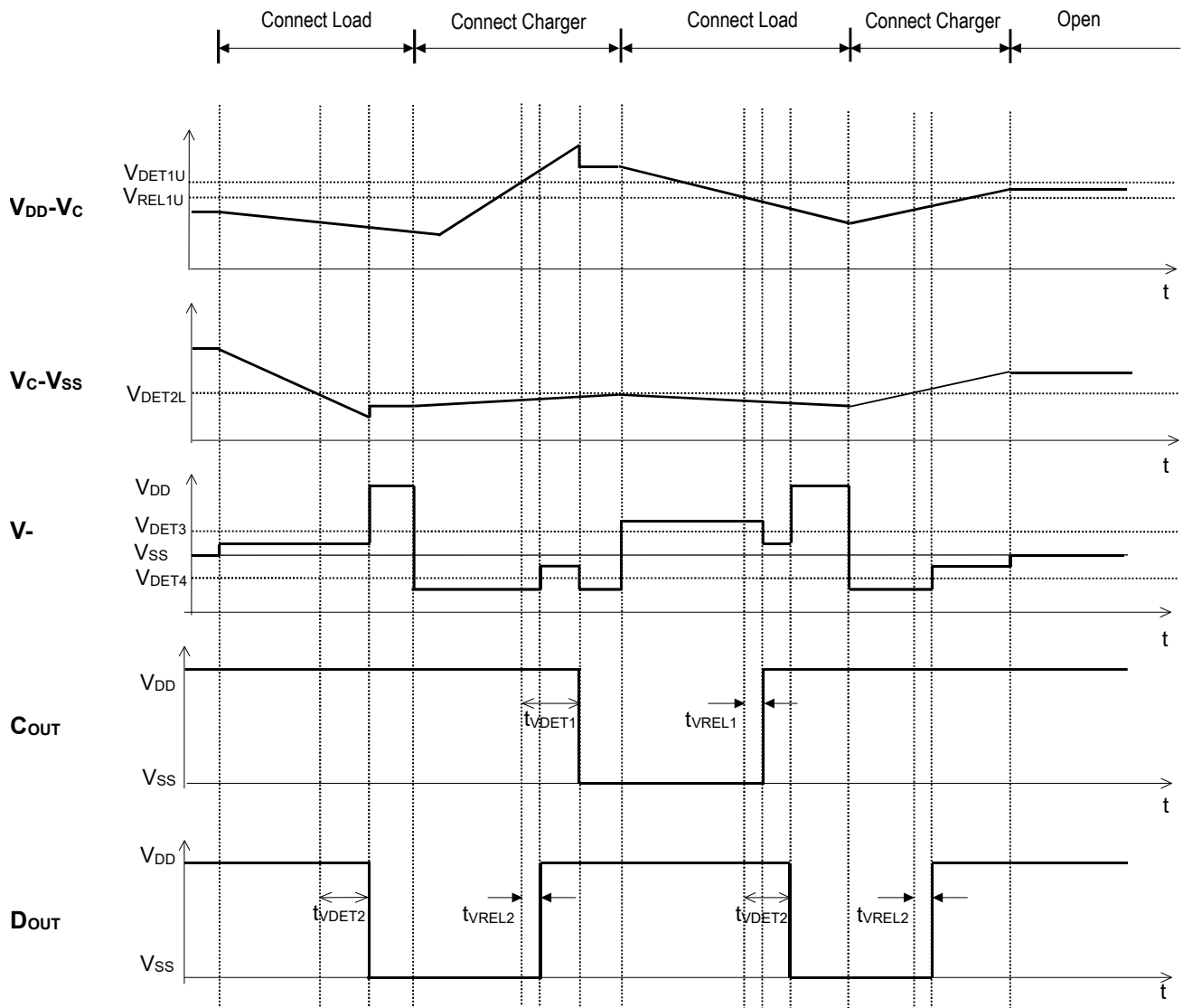

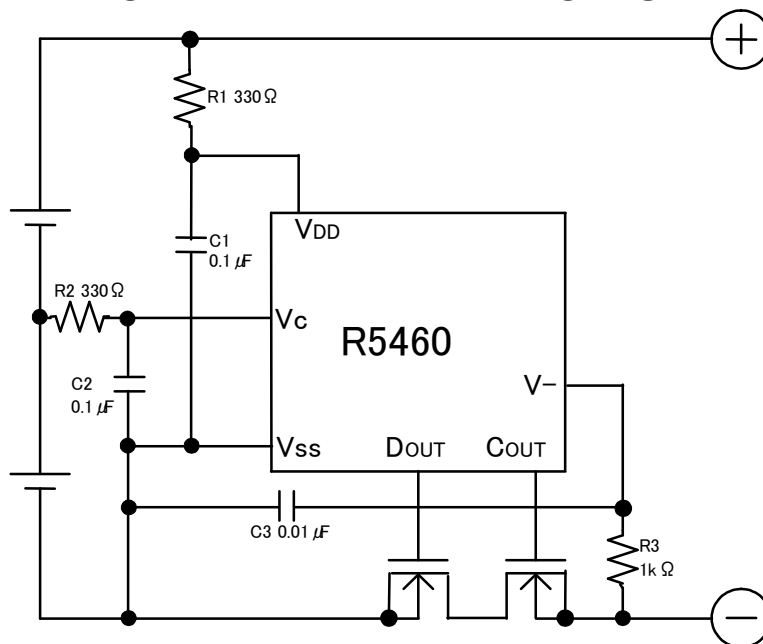
TYPICAL APPLICATION AND TECHNICAL NOTES**TECHNICAL NOTES**

R1, R2, C1 and C2 stabilize a supply voltage to the R5460xxxxx. A recommended R1, R2 value is less than 1kΩ. A larger value of R1 and R2 makes the detection voltage shift higher because of some conduction current in the R5460x2xxxx.

To stabilize the operation, the value of C1 and C2 should be equal or more than 0.01μF.

R1 and R3 can operate also as parts for current limit circuit against reverse charge or applying a charger with excess charging voltage beyond the absolute maximum rating of the R5460xxxxx, the battery pack. Small value of R1 and R3 may cause over-power consumption rating of power dissipation of the R5460xxxxx. Thus, the total value of 'R1+R3' should be equal or more than 1kΩ. If a large value R3 is set, after detecting over-discharge, the release by connecting a charger may not be possible. Therefore, recommendation value of R3 is equal or less than 3kΩ.

To stabilize the operation of the IC, make sure to mount 0.01μF or more capacitor as C3.

The typical application circuit diagram is just an example. This circuit performance largely depends on the PCB layout and external components. In the actual application, fully evaluation is necessary.

Over-voltage and the over current beyond the absolute maximum rating should not be forced to the protection IC and external components. Although the short protection circuit is built in the IC, if the positive terminal and the negative terminal of the battery pack are short, during the delay time of short limit detector, large current flows through the FET. Select an appropriate FET with large enough current capacity to prevent the IC from burning damage.

We are making our continuous effort to improve the quality and reliability of our products, but semiconductor products are likely to fail with certain probability. In order to prevent any injury to humans or damages to property resulting from such failure, users should be careful enough to incorporate safe measures in design, such as redundancy feature, fire-containment feature and fail-safe feature. We do not assume any liability or responsibility for any loss or damage arising from misuse or inappropriate use of the products.

TEST CIRCUITS

A

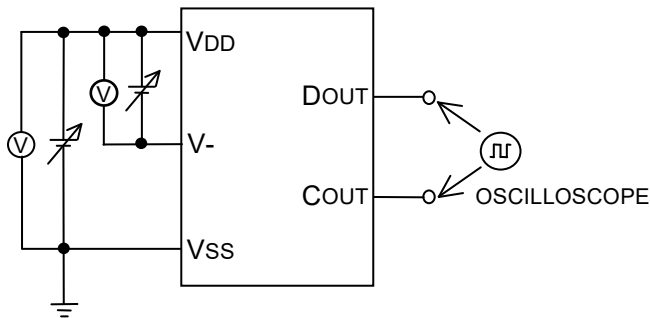

E

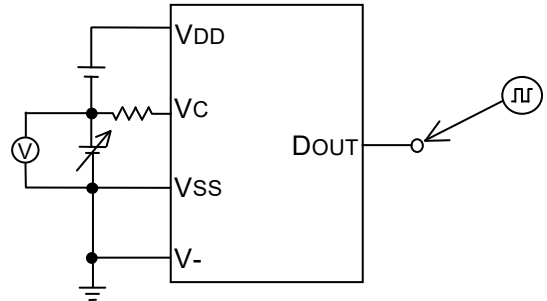

B

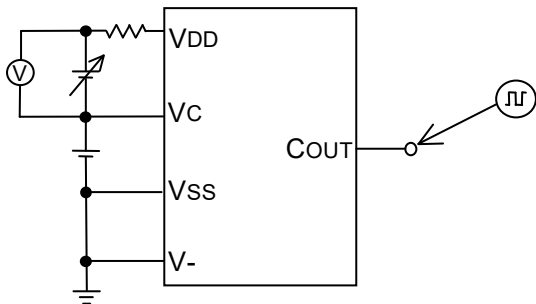

F

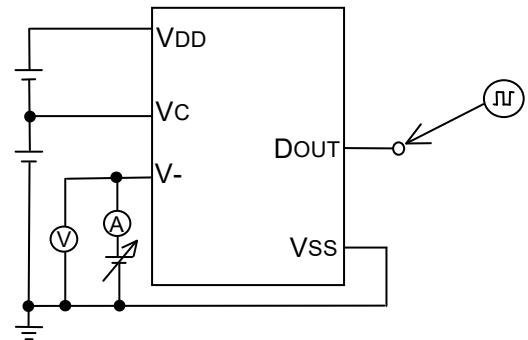

C

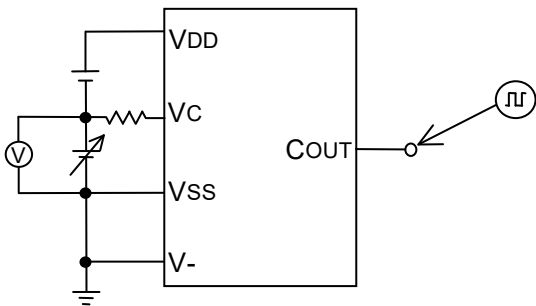

G

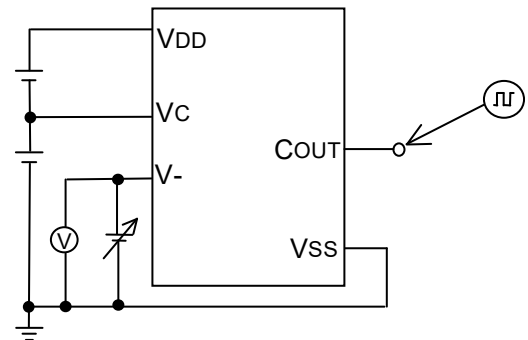

D

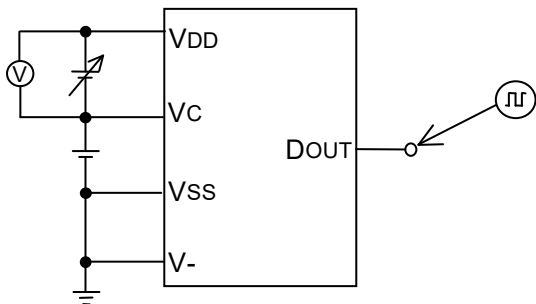

H

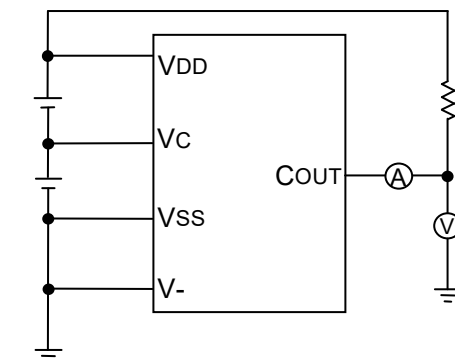

I

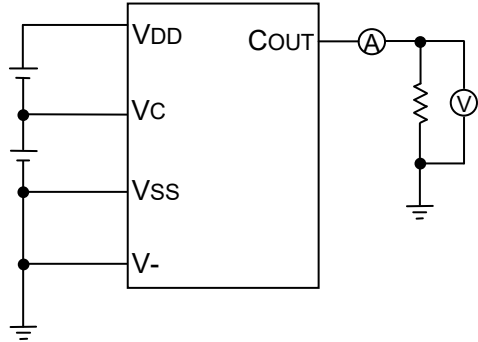

J

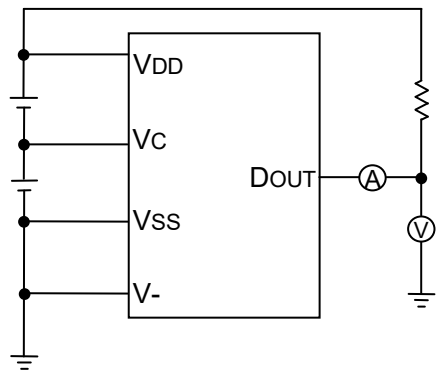

K

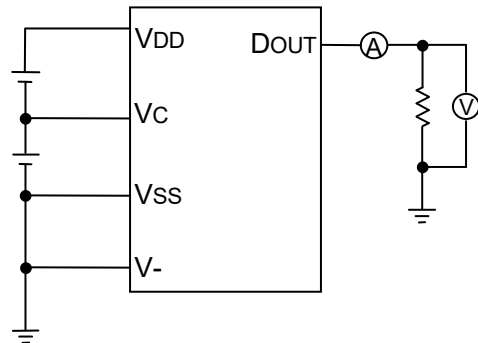

L

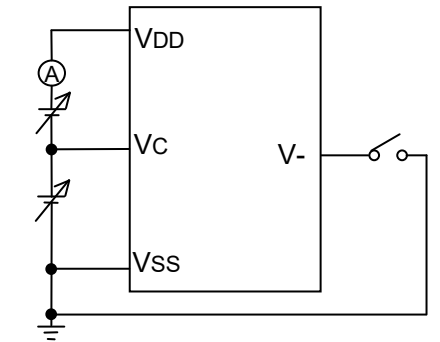

Typical Characteristics were obtained with using those above circuits:

Test Circuit A:	Part1: Typical characteristics 1)
Test Circuit B:	Part1: Typical characteristics 2) 4) 6) 7)
Test Circuit C:	Part1: Typical characteristics 3) 5)
Test Circuit D:	Part1: Typical characteristics 8) 10) 12) 13)
Test Circuit E:	Part1: Typical characteristics 9) 11)
Test Circuit F:	Part1: Typical characteristics 14) 15) 16) 17) 18) 19)
Test Circuit G:	Part1: Typical characteristics 20) 21) 22) 23)
Test Circuit H:	Part1: Typical characteristics 24)
Test Circuit I:	Part1: Typical characteristics 25)
Test Circuit J:	Part1: Typical characteristics 26)
Test Circuit K:	Part1: Typical characteristics 27)
Test Circuit L:	Part1: Typical characteristics 28) 29) 30)

TYPICAL CHARACTERISTICS (Part 1)

1) Minimum Operating Voltage for 0V Cell Charging
R5460x201AC
VDD=VSS=0V

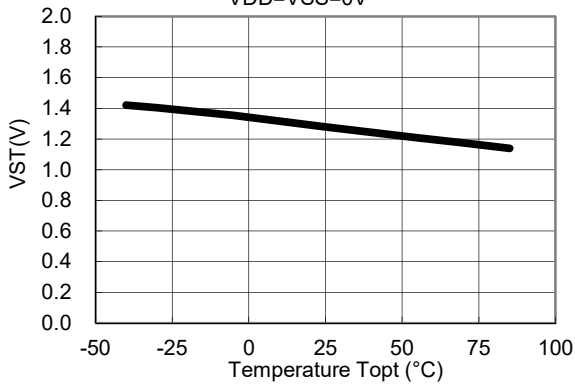

2) Over-charge voltage threshold (Cell1) vs. Temperature
R5460x201AC
Vc-Vss=3.5V

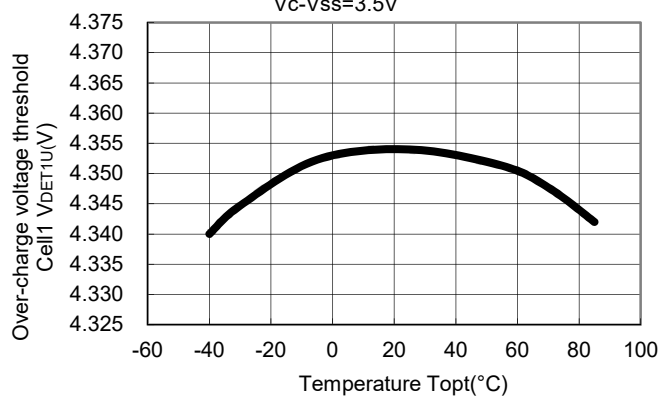

3) Over-Charge Voltage Threshold (Cell2) vs. Temperature
R5460x201AC
VDD-VC=3.5V

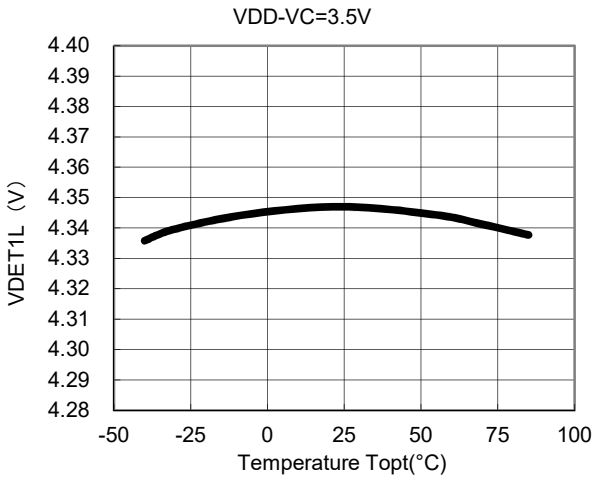

4) Release Voltage from Over-charge (Cell1) vs. Temperature
R5460x201AC
Vc-Vss=3.5V

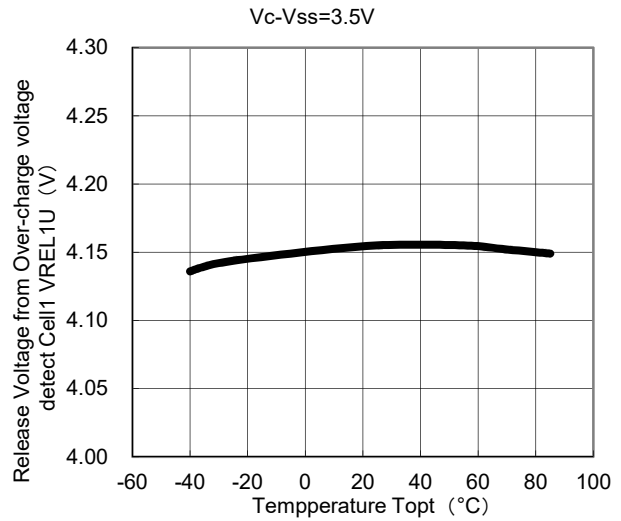

5) Release Voltage from Over-charge (Cell2) vs. Temperature

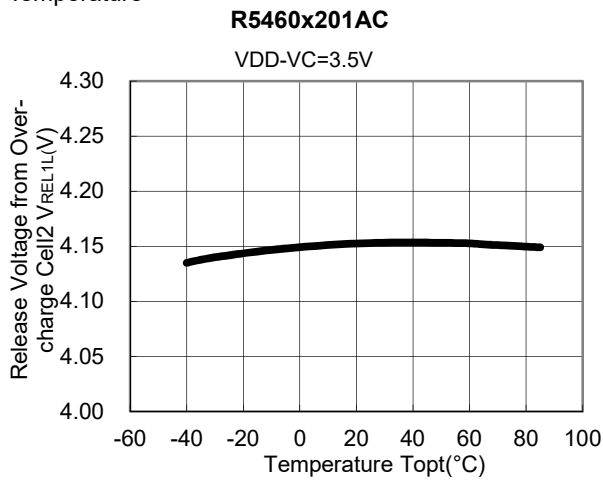

6) Output Delay of Over-charge Detector vs. Temperature

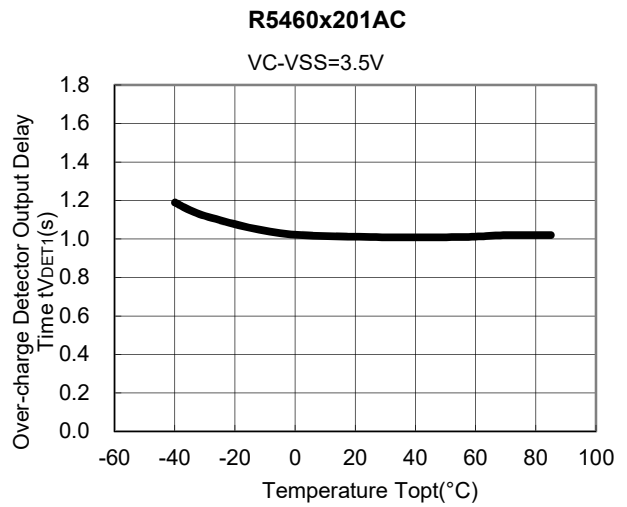

7) Output Delay of Release from Over-charge vs. Temperature

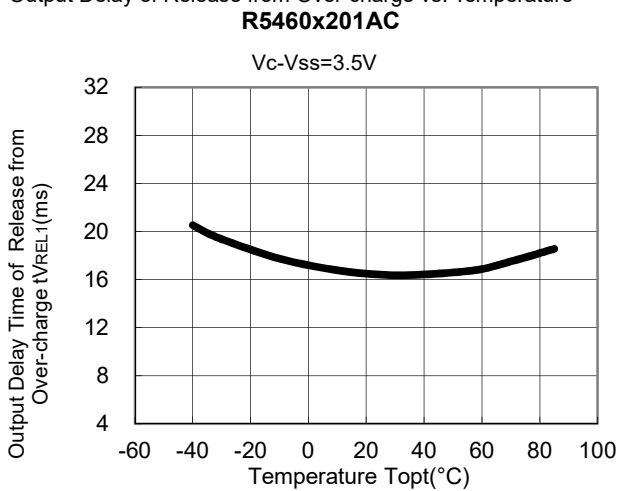

8) Over-discharge Detector Threshold (Cell1) vs. Temperature

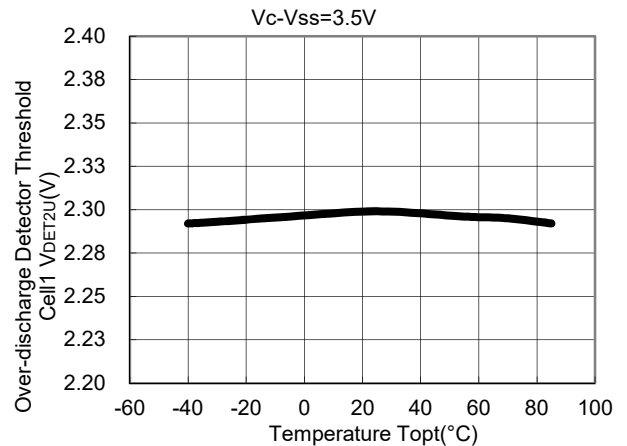

9) Over-discharge Detector Threshold (Cell2) vs. Temperature

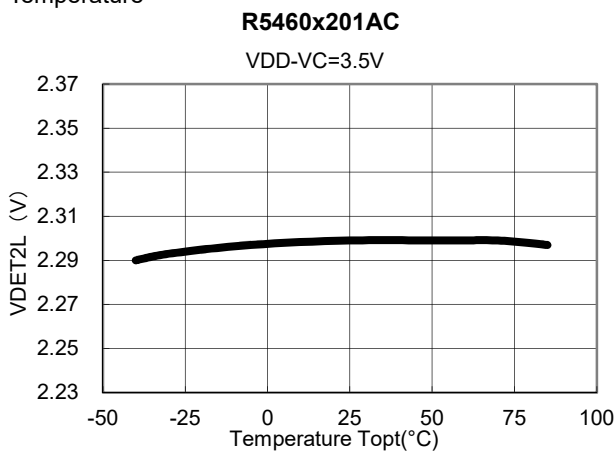

10) Release Voltage from Over-discharge (Cell1) vs. Temperature

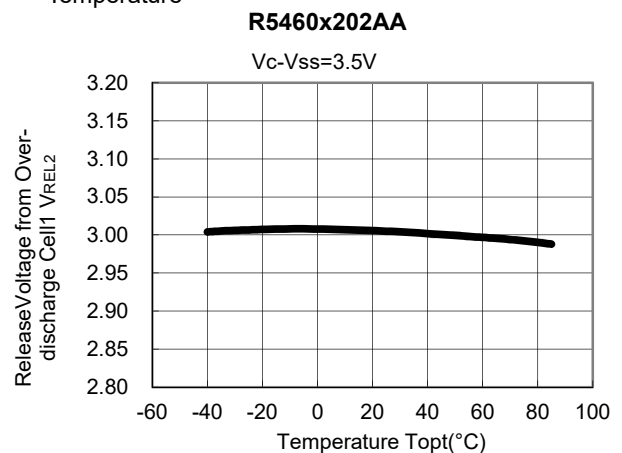

R5460x2xx

NO.EA-165-190704

11) Release Voltage from Over-discharge (Cell2) vs. Temperature

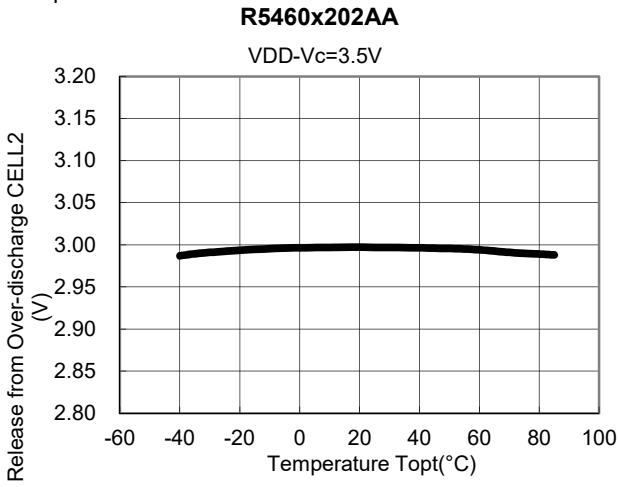

12) Output Delay Time for Over-discharge vs. Temperature

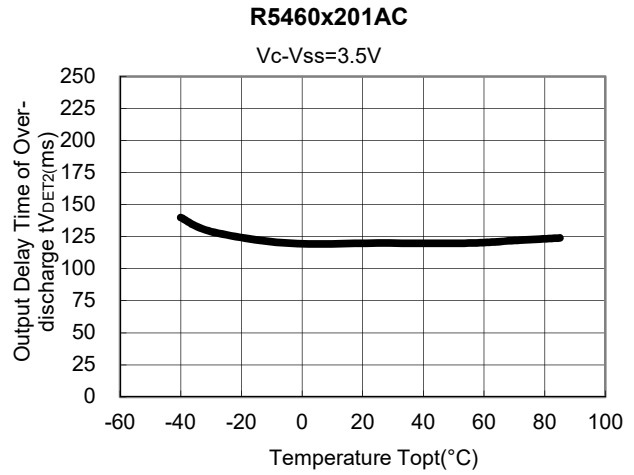

13) Output Delay of Release from Over-discharge vs. Temperature

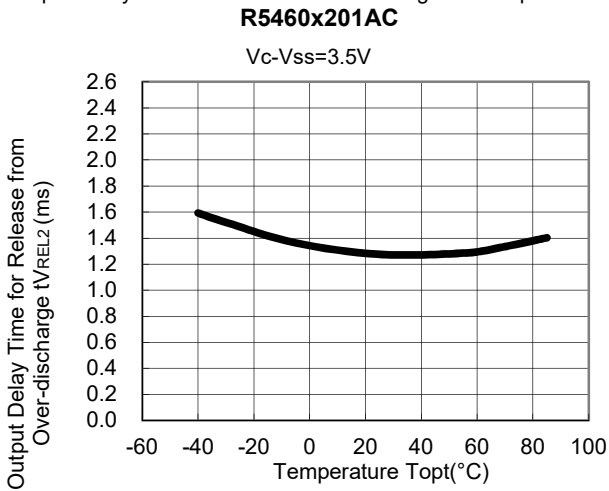

14) Excess discharge Current Detector Threshold vs. Temperature

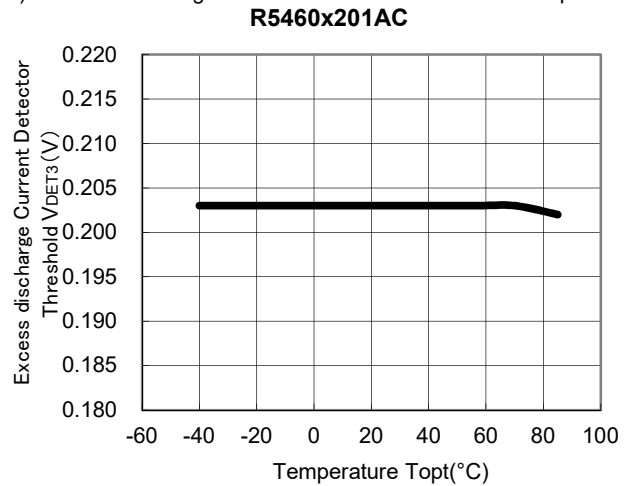

15) Output Delay Time for Excess discharge-current Detector vs. Temperature

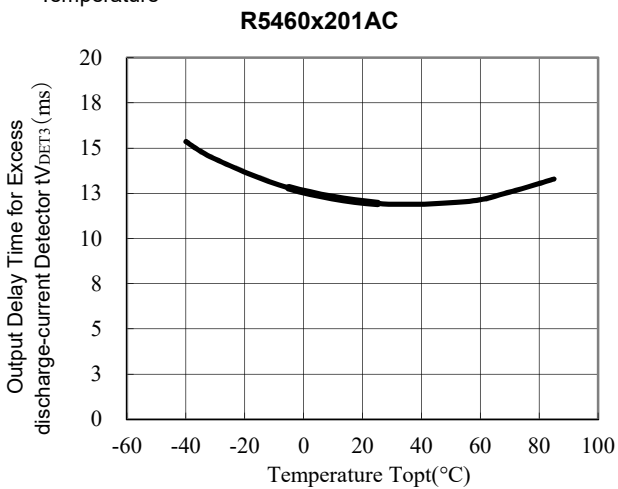

16) Output Delay for Release from Excess discharge-current vs. Temperature

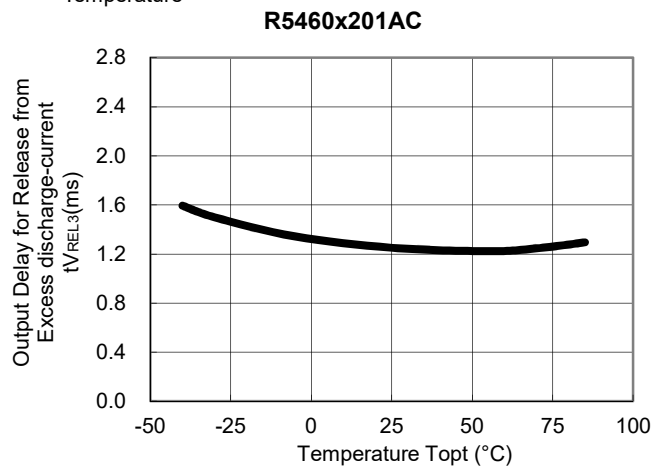

17) Short Detector Voltage Threshold vs. Temperature
R5460x201AC

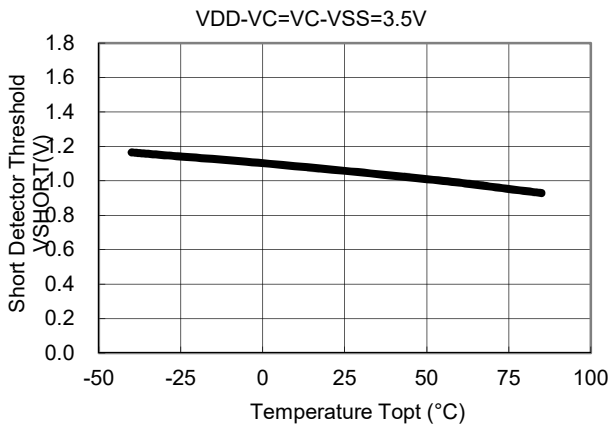

18) Output Delay for Short Detector vs. Temperature
R5460x201AC

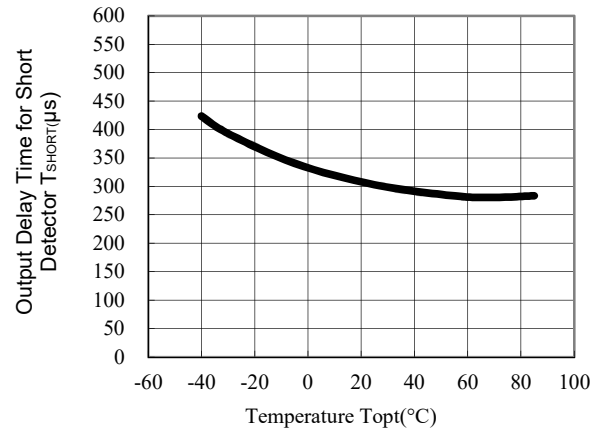

19) Release resistance from Excess-discharge current vs. Temperature

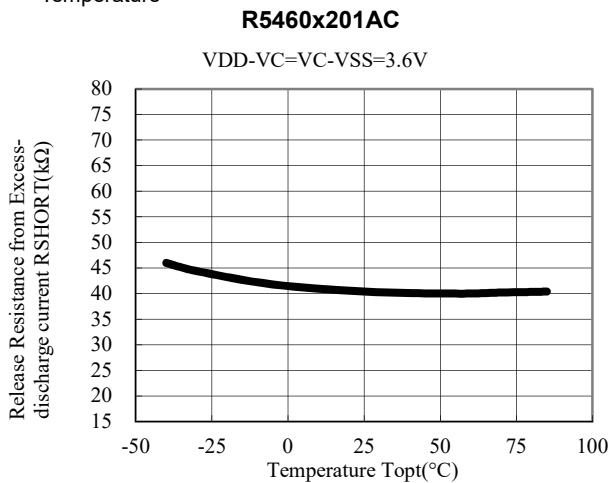

20) Excess-charge current Detector Threshold vs. Temperature

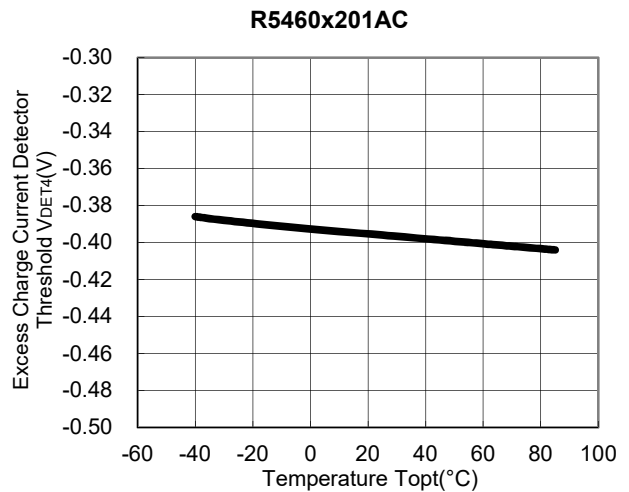

21) Output Delay Time of Excess-charge current Detector Threshold vs. Temperature

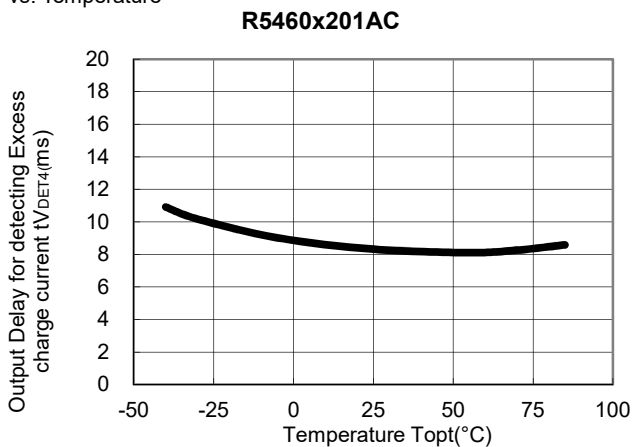

22) Output Delay Time for Release from Excess-charge current vs. Temperature

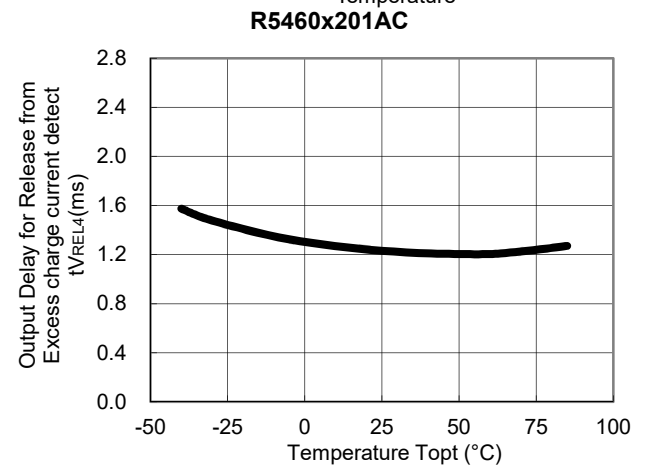

R5460x2xx

NO.EA-165-190704

23) Delay Shortening Mode Voltage vs. Temperature
R5460x201AC

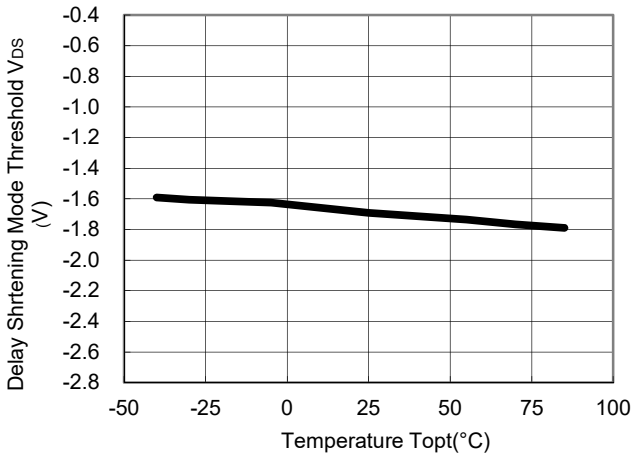

24) Nch ON Voltage of C_{OUT} vs. Temperature
R5460x201AC

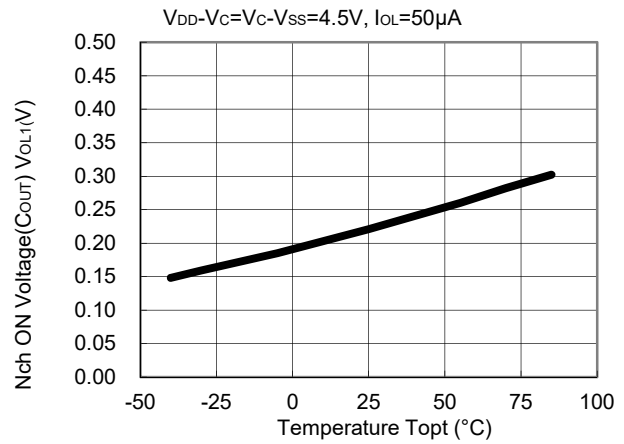

25) Pch ON Voltage of C_{OUT} vs. Temperature
R5460x201AC

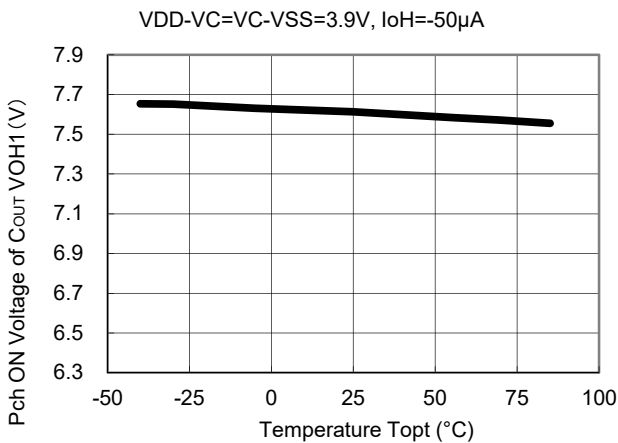

26) Nch ON Voltage of D_{OUT} vs. Temperature
R5460x201AC

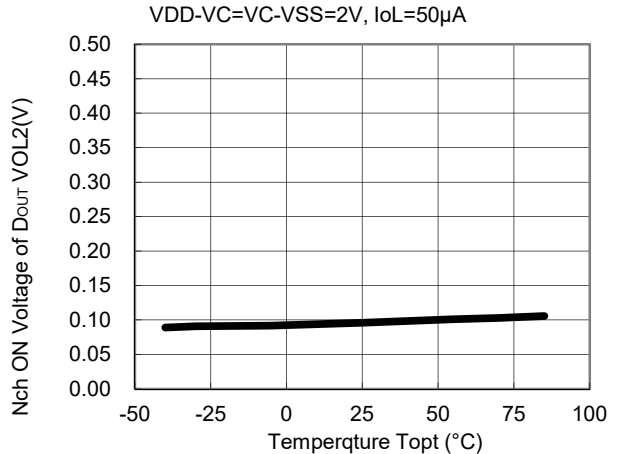

27) Pch ON Voltage of D_{OUT} vs. Temperature
R5460x201AC

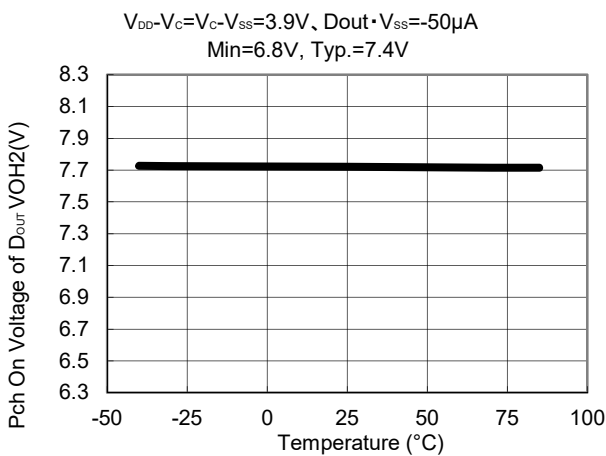

28) Supply Current vs. Temperature
R5460x201AC

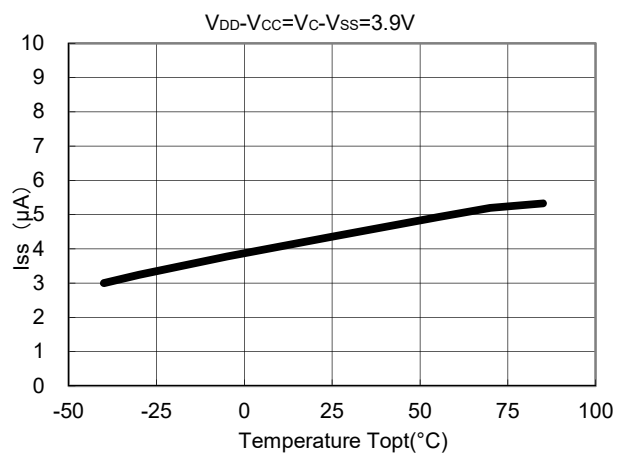

29) Standby Current vs. Temperature (Ver. A.)

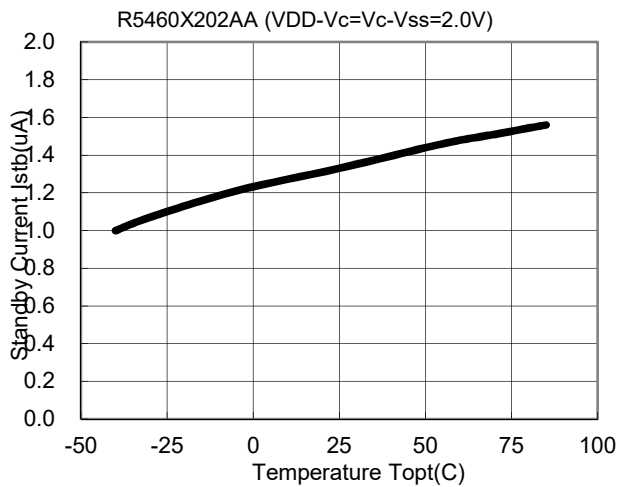

30) Standby Current vs. Temperature (Ver. B.)

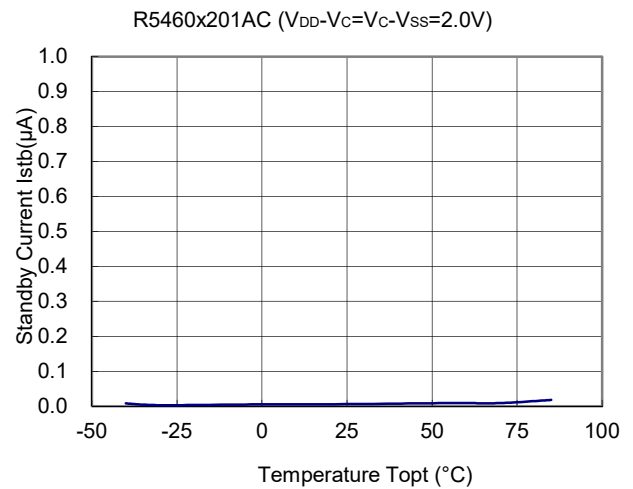

Part 2 Delay Time dependence on V_{DD}

1) Delay Time for Over-charge detector vs. V_{DD}

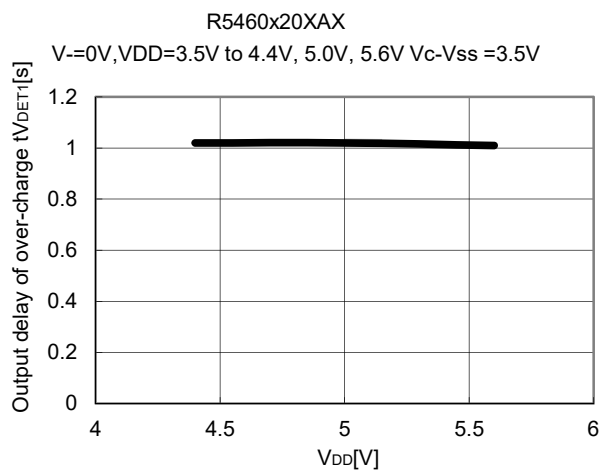

2) Delay Time for Release from Over-charge vs. V_{DD}

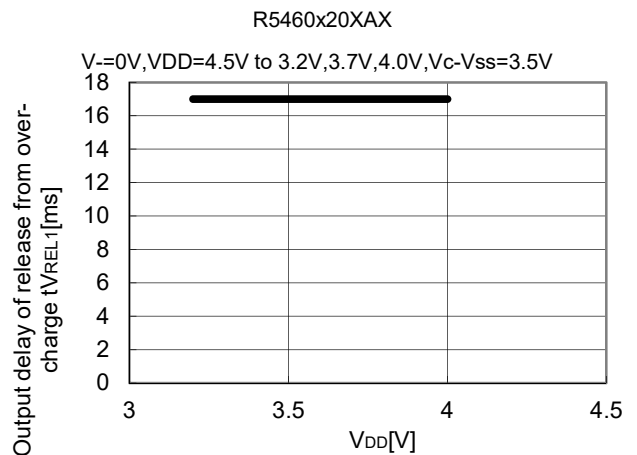

3) Output Delay of Over-discharge detector vs. V_{DD}

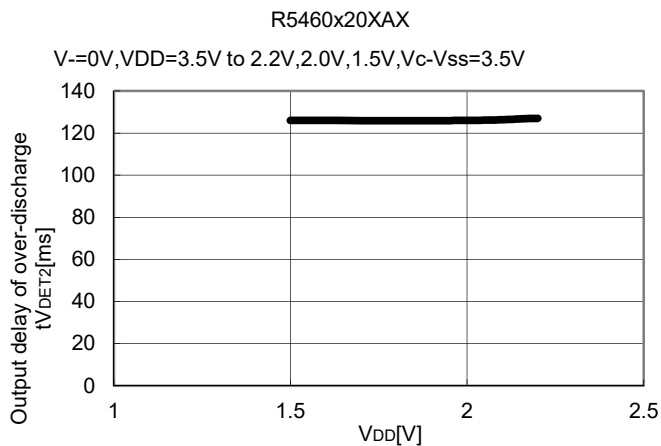

4) Output Delay for Release from Over-discharge vs. V_{DD}

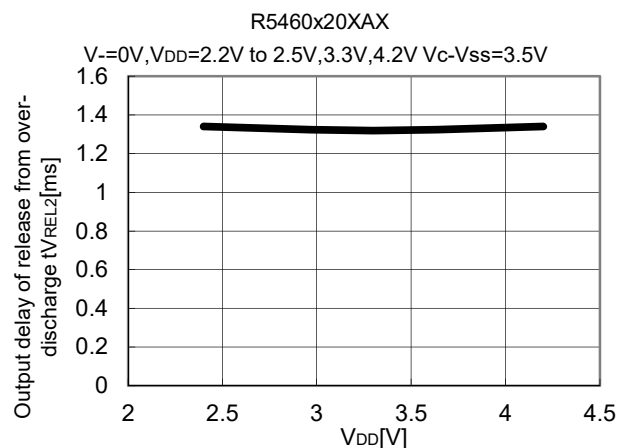

R5460x2xx

NO.EA-165-190704

- 5) Output Delay for Excess Discharge Current vs. V_{DD}

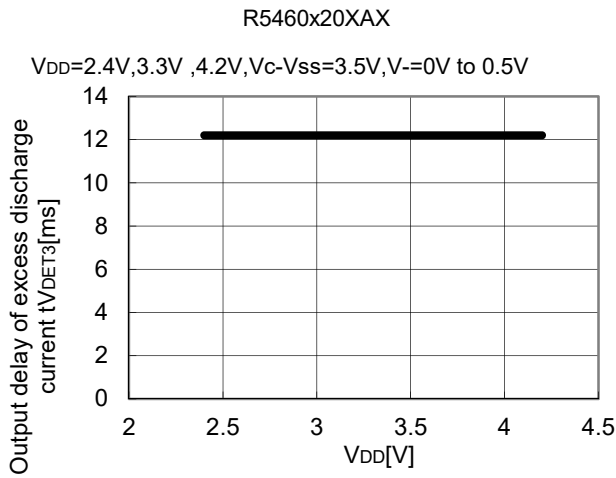

- 6) Output Delay for Release from Excess Discharge Current Detect vs. V_{DD}

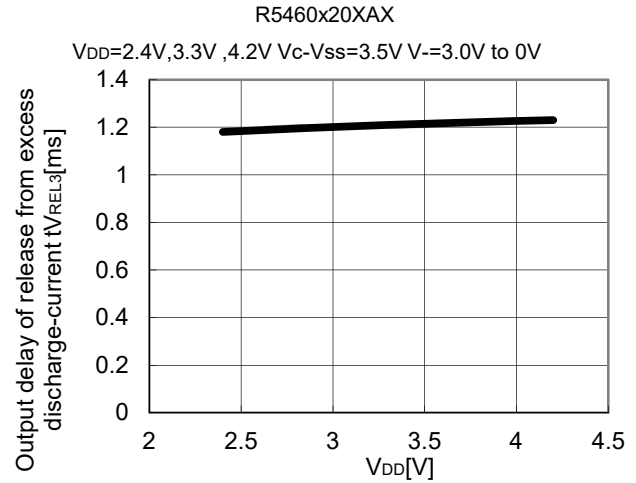

- 7) Delay Time for Excess Charge Current Detector vs. V_{DD}

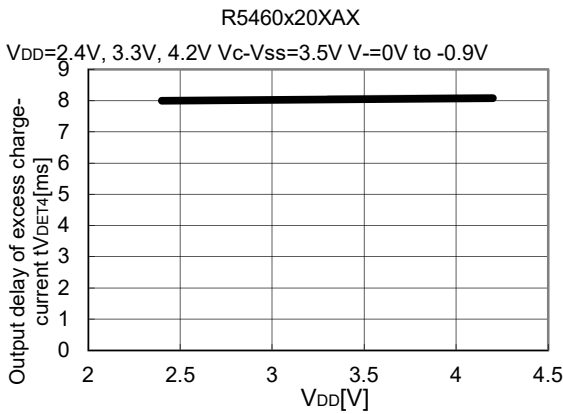

- 8) Delay Time for release from Excess charge current detect vs. V_{DD}

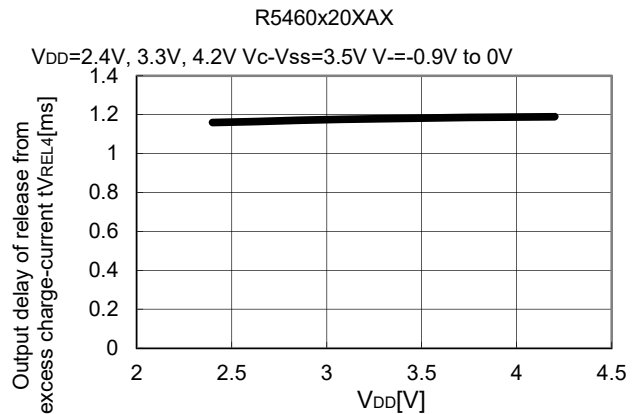

- 9) Output Delay for Short vs. V_{DD}

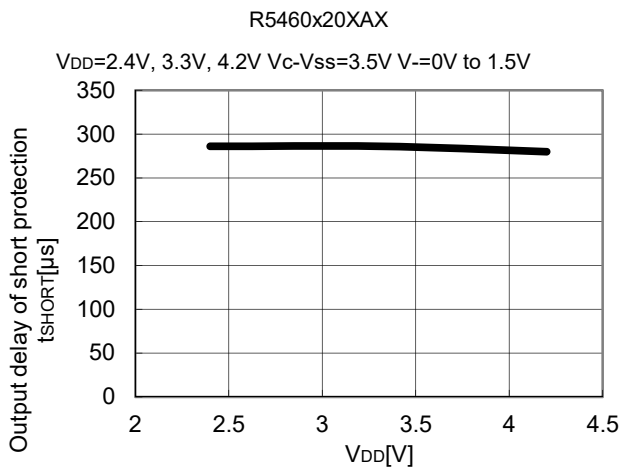

Part 3 Supply Current dependence on V_{DD}

Test Circuit

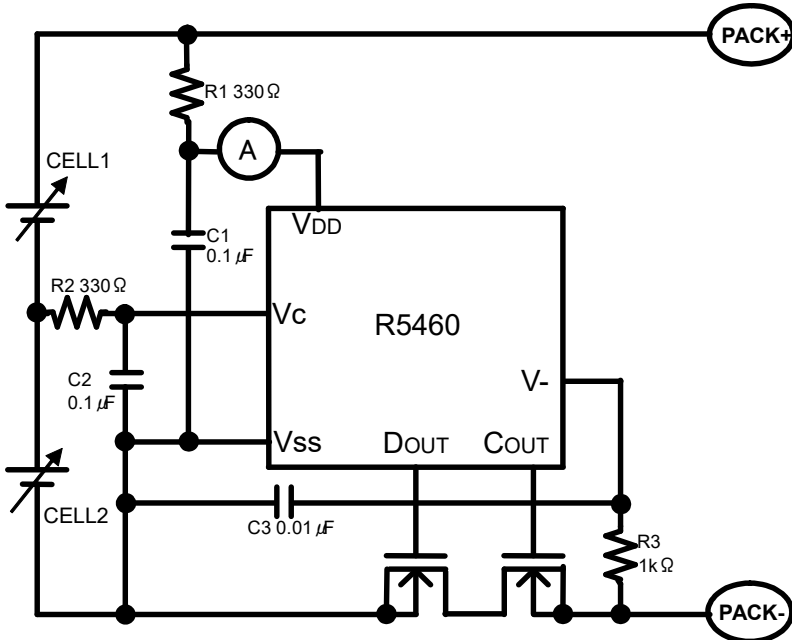

Supply Current vs. V_{DD}

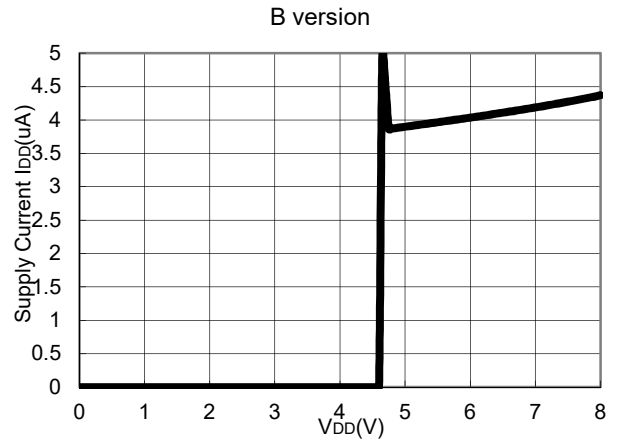
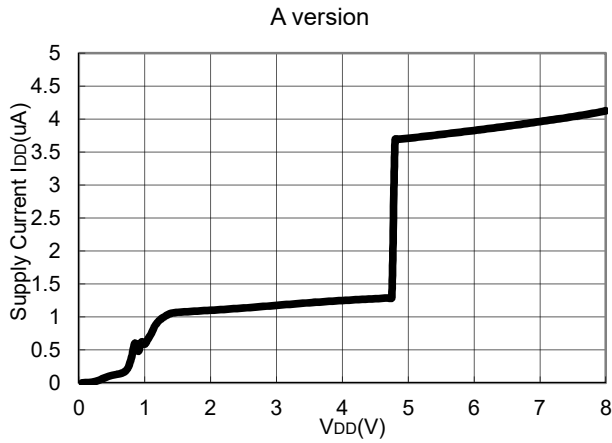

R5460x2xx

NO.EA-165-190704

Part 4 Over-charge detector, Release voltage from Over-charge, Over-discharge detector, Release voltage from Over-discharge dependence on External Resistance value

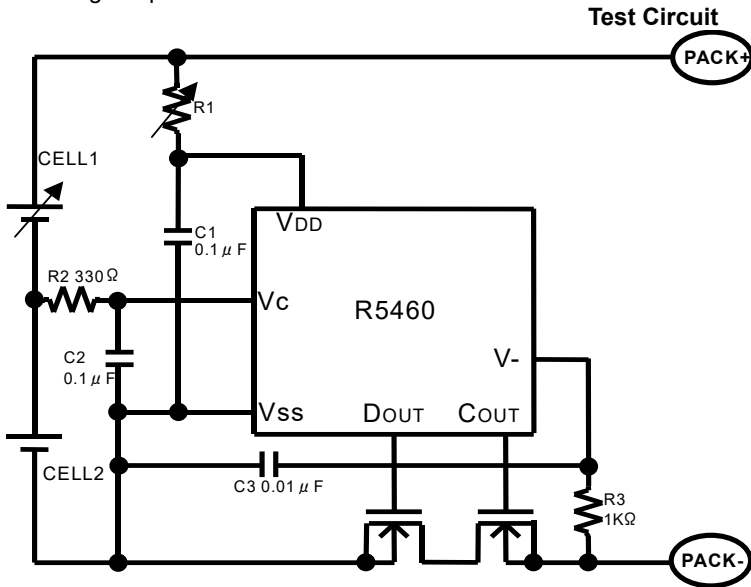

Over-charge Detector Threshold / Released Voltage from Over-discharge vs. R1

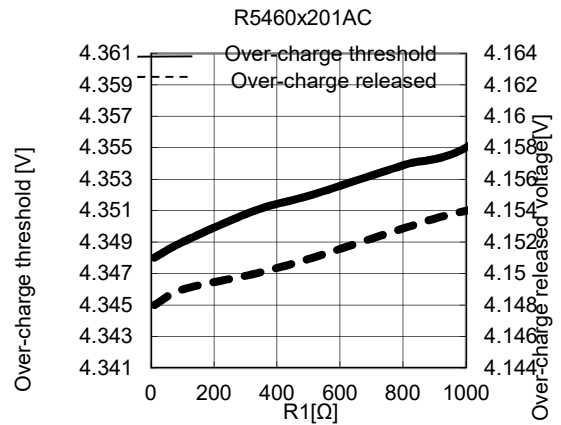
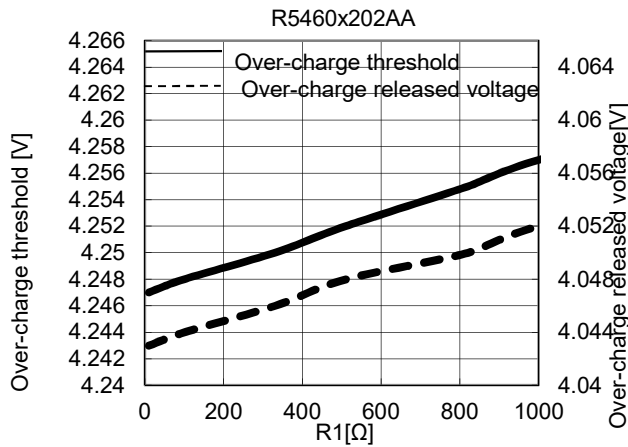

Over-discharge / Released from Over-charge Threshold vs. R1

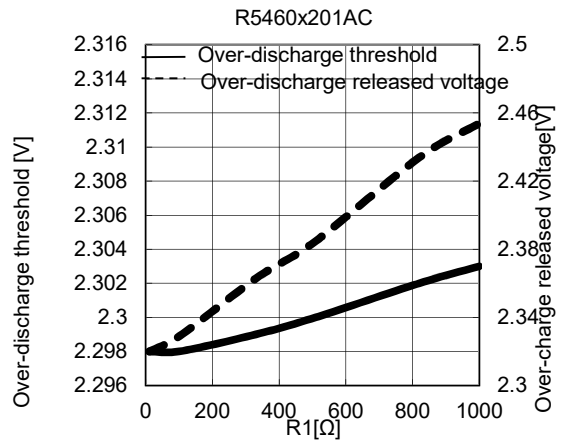
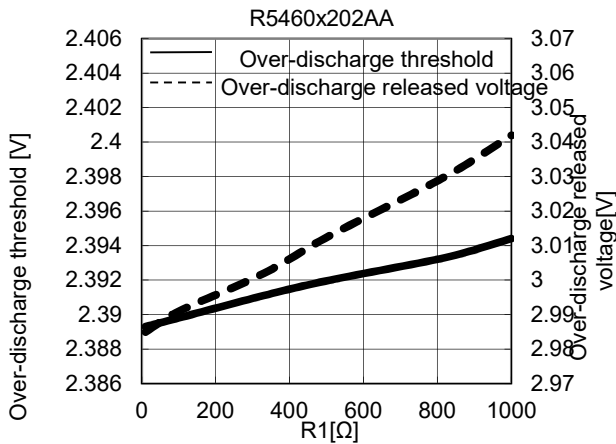

Part 5 Charger Voltage at Released from Over-discharge with a Charger dependence on R2

Test Circuit

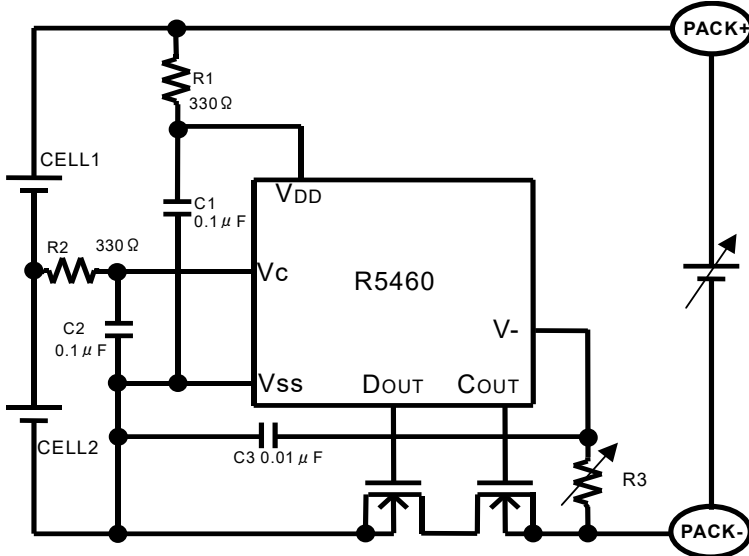

Charger Voltage at Release from Over-discharge with a charger vs. R2

R5460x201AC

CELL1=4.25V,CELL2=4.25V

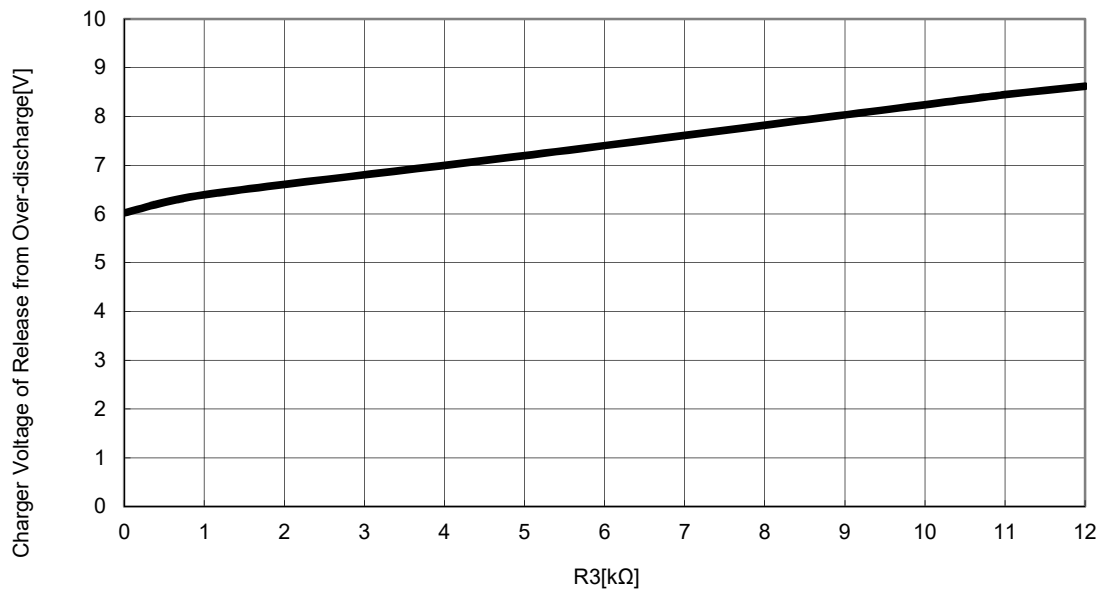

R5460x2xx

NO.EA-165-190704

R5460x2xxxx CODE LIST

2016.05

Product Name	Code Name	CELL1 Overcharge Detector Threshold VDET1U (V)	CELL1 Overcharge Release Threshold VREL1U (V)	CELL2 Overcharge Detector Threshold VDET1L (V)	CELL2 Overcharge Release Threshold VREL1L (V)	CELL1 Overdischarge Detector Threshold VDET2U (V)	CELL1 Overdischarge Release Threshold VREL2U (V)	CELL2 Overdischarge Detector Threshold VDET2L (V)	CELL2 Overdischarge Release threshold VREL2L (V)	Excess discharge-current Threshold VDET3 (V)	Excess charge-current Threshold VDET4 (V)	Overcharge Output Delay Time tVDET1 (s)	Overdischarge Output Delay Time tVDET2 (ms)
R5460N	201AC	4.350	4.150	4.350	4.150	2.300	-	2.300	-	0.200	-0.400	1	128
R5460N	202AA	4.250	4.050	4.250	4.050	2.400	3.000	2.400	3.000	0.150	-0.400	1	128
R5460N	203AA	4.350	4.150	4.350	4.150	2.300	3.000	2.300	3.000	0.200	-0.400	1	128
R5460N	204AA	4.350	4.150	4.350	4.150	2.300	3.000	2.300	3.000	0.150	-0.200	1	128
R5460N	205AA	4.250	4.050	4.250	4.050	2.400	3.000	2.400	3.000	0.100	-0.200	1	128
R5460N	206AA	4.290	4.050	4.290	4.050	2.900	3.100	2.900	3.100	0.150	-0.200	1	128
R5460N	207AA	4.350	4.150	4.350	4.150	2.300	3.000	2.300	3.000	0.200	-0.200	1	128
R5460N	207AE	4.350	4.150	4.350	4.150	2.300	3.000	2.300	3.000	0.200	-0.200	1	128
R5460N	207AF	4.350	4.150	4.350	4.150	2.300	3.000	2.300	3.000	0.200	-0.200	1	128
R5460N	208AA	4.250	4.050	4.250	4.050	2.400	3.000	2.400	3.000	0.200	-0.200	1	128
R5460N	208AE	4.250	4.050	4.250	4.050	2.400	3.000	2.400	3.000	0.200	-0.200	1	128
R5460N	208AF	4.250	4.050	4.250	4.050	2.400	3.000	2.400	3.000	0.200	-0.200	1	128
R5460N	209AD	3.650	3.450	3.650	3.450	2.500	3.000	2.500	3.000	0.200	-0.200	1	128
R5460N	210AD	3.650	3.450	3.650	3.450	2.000	2.500	2.000	2.500	0.200	-0.200	1	128
R5460N	211AA	4.250	4.050	4.250	4.050	3.000	3.200	3.000	3.200	0.150	-0.200	1	128
R5460N	212AA	4.290	4.050	4.290	4.050	3.000	3.200	3.000	3.200	0.200	-0.200	1	128
R5460N	212AE	4.290	4.050	4.290	4.050	3.000	3.200	3.000	3.200	0.200	-0.200	1	128
R5460N	212AF	4.290	4.050	4.290	4.050	3.000	3.200	3.000	3.200	0.200	-0.200	1	128
R5460N	213AD	3.900	3.450	3.900	3.450	2.000	2.500	2.000	2.500	0.200	-0.200	1	128
R5460N	214AC	4.250	4.050	4.250	4.050	2.800	-	2.800	-	0.200	-0.200	1	128
R5460N	214AE	4.250	4.050	4.250	4.050	2.800	3.000	2.800	3.000	0.200	-0.200	1	128
R5460N	214AF	4.250	4.050	4.250	4.050	2.800	3.000	2.800	3.000	0.200	-0.200	1	128
R5460N	215AF	4.300	4.100	4.300	4.100	3.200	3.400	3.200	3.400	0.150	-0.200	1	128
R5460N	218AF	4.250	4.050	4.250	4.050	2.800	3.000	2.800	3.000	0.200	-0.100	1	128
R5460N	222AA	4.200	4.100	4.200	4.100	2.700	2.850	2.700	2.850	0.200	-0.200	1	128
R5460N	223AA	4.250	4.100	4.250	4.100	2.500	3.000	2.500	3.000	0.100	-0.100	1	128
R5460N	225AF	4.300	4.100	4.300	4.100	3.000	3.200	3.000	3.200	0.200	-0.150	1	128
R5460N	227AA	4.425	4.000	4.425	4.000	2.800	3.000	2.800	3.000	0.150	-0.150	1	128
R5460N	229AD	3.650	3.300	3.650	3.300	2.000	2.500	2.000	2.500	0.200	-0.200	1	128
R5460N	230AA	4.375	4.175	4.375	4.175	2.500	2.700	2.500	2.700	0.100	-0.100	1	128
R5460N	233AF	4.100	3.950	4.100	3.950	2.800	3.000	2.800	3.000	0.200	-0.200	1	128
R5460N	235AA	4.475	4.275	4.475	4.275	2.600	2.900	2.600	2.900	0.200	-0.200	1	128

R5460x 2xx A x

Package Type
N: SOT-23-6
K: PLP1820-6

Function Version

- A: Over-Charge = Auto-Release, Over-Discharge = Auto Release
- C: Over-Charge = Auto-Release, Over-Discharge = Latch
- D: Over-Charge = Auto-Release, Over-Discharge = Auto Release, VDET1UIL < 4.0V
- E: Over-Charge = Auto-Release, Over-Discharge = Auto Release (No Hysteresis Cancellation)
- F: Over-Charge = Auto-Release, Over-Discharge = Latch (Hysteresis)

Delay Time Version

Ver.	tVdet1(s)	tVdet2(ms)	tVdet3(ms)	tVdet4(ms)	tSHORT(μA)
A	1	128	12	8	300



1. The products and the product specifications described in this document are subject to change or discontinuation of production without notice for reasons such as improvement. Therefore, before deciding to use the products, please refer to Ricoh sales representatives for the latest information thereon.
2. The materials in this document may not be copied or otherwise reproduced in whole or in part without prior written consent of Ricoh.
3. Please be sure to take any necessary formalities under relevant laws or regulations before exporting or otherwise taking out of your country the products or the technical information described herein.
4. The technical information described in this document shows typical characteristics of and example application circuits for the products. The release of such information is not to be construed as a warranty of or a grant of license under Ricoh's or any third party's intellectual property rights or any other rights.
5. The products listed in this document are intended and designed for use as general electronic components in standard applications (office equipment, telecommunication equipment, measuring instruments, consumer electronic products, amusement equipment etc.). Those customers intending to use a product in an application requiring extreme quality and reliability, for example, in a highly specific application where the failure or misoperation of the product could result in human injury or death (aircraft, spacevehicle, nuclear reactor control system, traffic control system, automotive and transportation equipment, combustion equipment, safety devices, life support system etc.) should first contact us.
6. We are making our continuous effort to improve the quality and reliability of our products, but semiconductor products are likely to fail with certain probability. In order to prevent any injury to persons or damages to property resulting from such failure, customers should be careful enough to incorporate safety measures in their design, such as redundancy feature, fire containment feature and fail-safe feature. We do not assume any liability or responsibility for any loss or damage arising from misuse or inappropriate use of the products.
7. Anti-radiation design is not implemented in the products described in this document.
8. The X-ray exposure can influence functions and characteristics of the products. Confirm the product functions and characteristics in the evaluation stage.
9. WLCSP products should be used in light shielded environments. The light exposure can influence functions and characteristics of the products under operation or storage.
10. There can be variation in the marking when different AOI (Automated Optical Inspection) equipment is used. In the case of recognizing the marking characteristic with AOI, please contact Ricoh sales or our distributor before attempting to use AOI.
11. Please contact Ricoh sales representatives should you have any questions or comments concerning the products or the technical information.



Ricoh is committed to reducing the environmental loading materials in electrical devices with a view to contributing to the protection of human health and the environment.

Ricoh has been providing RoHS compliant products since April 1, 2006 and Halogen-free products since April 1, 2012.

RICOH RICOH ELECTRONIC DEVICES CO., LTD.

<https://www.e-devices.ricoh.co.jp/en/>

Sales & Support Offices

Ricoh Electronic Devices Co., Ltd.

Shin-Yokohama Office (International Sales)

2-3, Shin-Yokohama 3-chome, Kohoku-ku, Yokohama-shi, Kanagawa, 222-8530, Japan
Phone: +81-50-3814-7687 Fax: +81-45-474-0074

Ricoh Americas Holdings, Inc.

675 Campbell Technology Parkway, Suite 200 Campbell, CA 95008, U.S.A.
Phone: +1-408-610-3105

Ricoh Europe (Netherlands) B.V.

Semiconductor Support Centre

Prof. W.H. Keesomlaan 1, 1183 DJ Amstelveen, The Netherlands
Phone: +31-20-5474-309

Ricoh International B.V. - German Branch

Semiconductor Sales and Support Centre

Oberrather Strasse 6, 40472 Düsseldorf, Germany
Phone: +49-211-6546-0

Ricoh Electronic Devices Korea Co., Ltd.

3F, Haesung Bldg, 504, Teheran-ro, Gangnam-gu, Seoul, 135-725, Korea
Phone: +82-2-2135-5700 Fax: +82-2-2051-5713

Ricoh Electronic Devices Shanghai Co., Ltd.

Room 403, No.2 Building, No.690 Bibo Road, Pu Dong New District, Shanghai 201203,
People's Republic of China
Phone: +86-21-5027-3200 Fax: +86-21-5027-3299

Ricoh Electronic Devices Shanghai Co., Ltd.

Shenzhen Branch

1205, Block D (Jinlong Building), Kingkey 100, Hongbao Road, Luohu District,
Shenzhen, China
Phone: +86-755-8348-7600 Ext 225

Ricoh Electronic Devices Co., Ltd.

Taipei office

Room 109, 10F-1, No.51, Hengyang Rd., Taipei City, Taiwan
Phone: +886-2-2313-1621/1622 Fax: +886-2-2313-1623

Mouser Electronics

Authorized Distributor

Click to View Pricing, Inventory, Delivery & Lifecycle Information:

Ricoh Electronics:

[R5460N206AA-TR-FE](#) [R5460N207AA-TR-FE](#) [R5460N208AA-TR-FE](#) [R5460N208AF-TR-FE](#) [R5460N209AD-TR-FE](#)
[R5460N210AD-TR-FE](#) [R5460N212AF-TR-FE](#) [R5460N222AA-TR-FE](#) [R5460N229AD-TR-FE](#)



Стандарт Электрон Связь

Мы молодая и активно развивающаяся компания в области поставок электронных компонентов. Мы поставляем электронные компоненты отечественного и импортного производства напрямую от производителей и с крупнейших складов мира.

Благодаря сотрудничеству с мировыми поставщиками мы осуществляем комплексные и плановые поставки широчайшего спектра электронных компонентов.

Собственная эффективная логистика и склад в обеспечивает надежную поставку продукции в точно указанные сроки по всей России.

Мы осуществляем техническую поддержку нашим клиентам и предпродажную проверку качества продукции. На все поставляемые продукты мы предоставляем гарантию .

Осуществляем поставки продукции под контролем ВП МО РФ на предприятия военно-промышленного комплекса России , а также работаем в рамках 275 ФЗ с открытием отдельных счетов в уполномоченном банке. Система менеджмента качества компании соответствует требованиям ГОСТ ISO 9001.

Минимальные сроки поставки, гибкие цены, неограниченный ассортимент и индивидуальный подход к клиентам являются основой для выстраивания долгосрочного и эффективного сотрудничества с предприятиями радиоэлектронной промышленности, предприятиями ВПК и научно-исследовательскими институтами России.

С нами вы становитесь еще успешнее!

Наши контакты:

Телефон: +7 812 627 14 35

Электронная почта: sales@st-electron.ru

Адрес: 198099, Санкт-Петербург,
Промышленная ул, дом № 19, литера Н,
помещение 100-Н Офис 331