

256-Kbit (32 K × 8) nvSRAM with Real Time Clock

Features

- 256-Kbit nonvolatile static random access memory (nvSRAM)
 - 25 ns and 45 ns access times
 - Internally organized as 32 K × 8 (CY14B256KA)
 - Hands off automatic STORE on power-down with only a small capacitor
 - STORE to QuantumTrap nonvolatile elements is initiated by software, hardware, or AutoStore on power-down
 - RECALL to SRAM initiated on power-up or by software
- High reliability
 - Infinite Read, Write, and RECALL cycles
 - 1 million STORE cycles to QuantumTrap
 - 20 year data retention
- Real time clock (RTC)
 - Full-featured real time clock
 - Watchdog timer
 - Clock alarm with programmable interrupts
 - Capacitor or battery backup for RTC
 - Backup current of 0.35 μ A (Typ)

Industry standard configurations

- Single 3 V +20%, -10% operation
- Industrial temperature
- 48-pin shrink small-outline package (SSOP)
- Pb-free and Restriction of hazardous substances (RoHS) compliant

Functional Description

The Cypress CY14B256KA combines a 256-Kbit nonvolatile static RAM with a full featured real time clock in a monolithic integrated circuit. The embedded nonvolatile elements incorporate QuantumTrap technology producing the world's most reliable nonvolatile memory. The SRAM is read and written an infinite number of times, while independent nonvolatile data resides in the nonvolatile elements.

The real time clock function provides an accurate clock with leap year tracking and a programmable, high accuracy oscillator. The alarm function is programmable for periodic minutes, hours, days, or months alarms. There is also a programmable watchdog timer for process control.

Logic Block Diagram

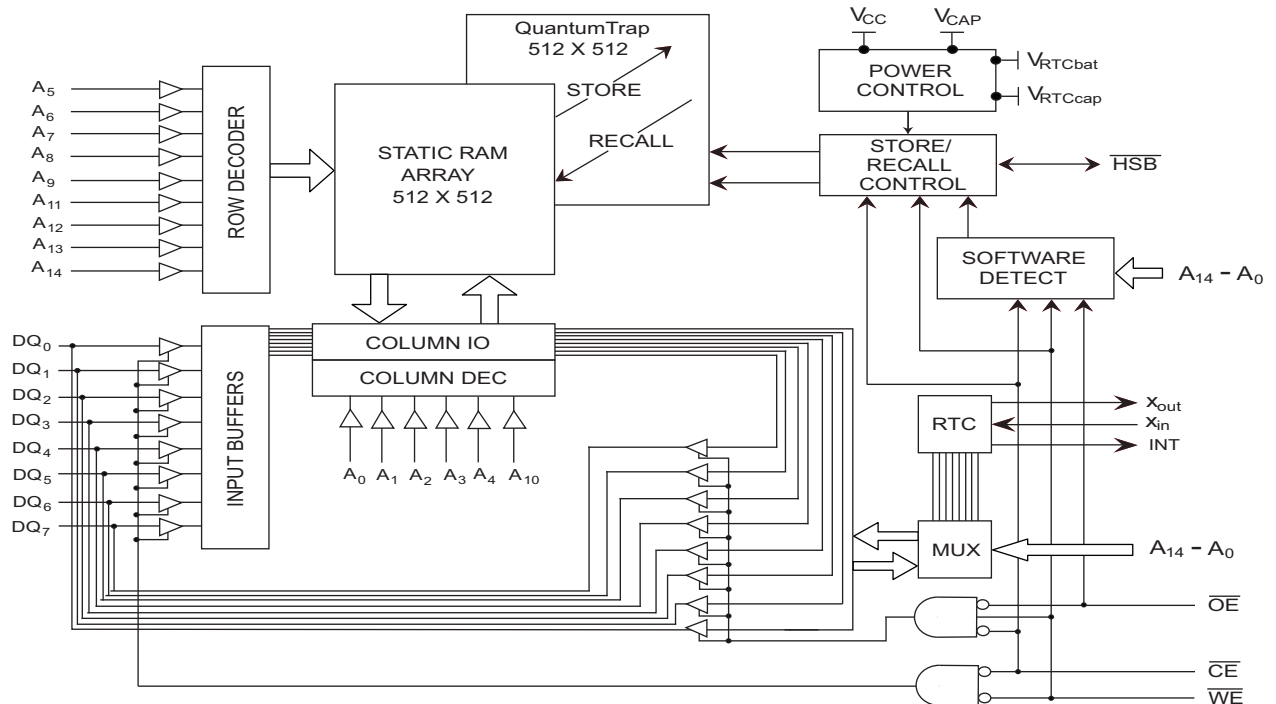

Contents

Pinouts	3	Data Retention and Endurance	16
Pin Definitions	3	Capacitance	16
Device Operation	4	Thermal Resistance	16
SRAM Read	4	AC Test Loads	17
SRAM Write	4	AC Test Conditions	17
AutoStore Operation	4	RTC Characteristics	17
Hardware STORE (HSB) Operation	4	AC Switching Characteristics	18
Hardware RECALL (Power-Up)	5	SRAM Read Cycle	18
Software STORE	5	SRAM Write Cycle	18
Software RECALL	5	AutoStore/Power-Up RECALL	20
Preventing AutoStore	7	Switching Waveforms	20
Data Protection	7	Software Controlled STORE/RECALL Cycle	21
Real Time Clock Operation	7	Switching Waveforms	21
nvTIME Operation	7	Hardware STORE Cycle	22
Clock Operations	7	Switching Waveforms	22
Reading the Clock	7	Truth Table For SRAM Operations	23
Setting the Clock	7	Ordering Information	23
Backup Power	7	Ordering Code Definitions	23
Stopping and Starting the Oscillator	8	Package Diagram	24
Calibrating the Clock	8	Acronyms	25
Alarm	8	Document Conventions	25
Watchdog Timer	9	Units of Measure	25
Power Monitor	9	Document History Page	26
Interrupts	9	Sales, Solutions, and Legal Information	27
Flags Register	10	Worldwide Sales and Design Support	27
Maximum Ratings	15	Products	27
Operating Range	15	PSoC Solutions	27
DC Electrical Characteristics	15		

Pinouts

Figure 1. 48-pin SSOP pinout

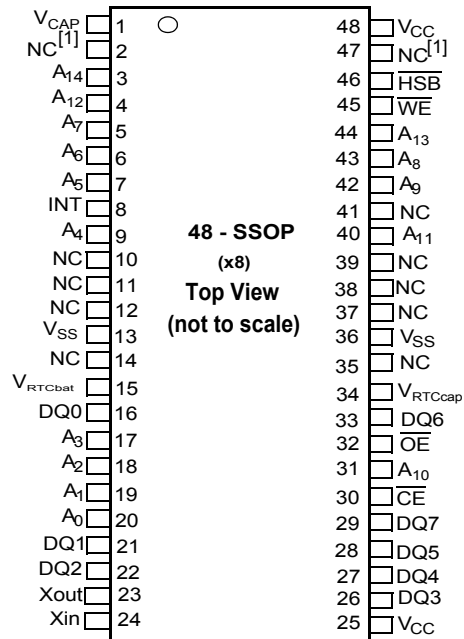

Pin Definitions

Pin Name	I/O Type	Description
A ₀ –A ₁₄	Input	Address inputs. Used to select One of the 32,768 bytes of the nvSRAM.
DQ ₀ –DQ ₇	Input/Output	Bidirectional data I/O Lines. Used as input or output lines depending on operation.
NC	No connect	No connect. This pin is not connected to the die.
\overline{WE}	Input	Write Enable input, Active LOW. When the chip is enabled and WE is LOW, data on the I/O pins is written to the specific address location.
\overline{CE}	Input	Chip Enable input, Active LOW. When LOW, selects the chip. When HIGH, deselects the chip.
\overline{OE}	Input	Output Enable, Active LOW. The active LOW OE input enables the data output buffers during read cycles. Deasserting OE HIGH causes the I/O pins to tristate.
X _{out} ^[2]	Output	Crystal connection. Drives crystal on start up.
X _{in} ^[2]	Input	Crystal connection. For 32.768 kHz crystal.
V _{RTccap} ^[2]	Power supply	Capacitor supplied backup RTC supply voltage. Left unconnected if V _{RTcbat} is used.
V _{RTcbat} ^[2]	Power supply	Battery supplied backup RTC supply voltage. Left unconnected if V _{RTccap} is used.
INT ^[2]	Output	Interrupt output. Programmable to respond to the clock alarm, the watchdog timer, and the power monitor. Also programmable to either active HIGH (push or pull) or LOW (open drain).
V _{SS}	Ground	Ground for the device. Must be connected to the ground of the system.
V _{CC}	Power supply	Power supply inputs to the Device. 3.0 V +20%, –10%
\overline{HSB}	Input/Output	Hardware STORE Busy (HSB). When LOW, this output indicates that a Hardware STORE is in progress. When pulled LOW, external to the chip, it initiates a nonvolatile STORE operation. After each Hardware and Software STORE operation HSB is driven HIGH for a short time (t _{HHHD}) with standard output high current and then a weak internal pull-up resistor keeps this pin HIGH (external pull-up resistor connection optional).
V _{CAP}	Power supply	AutoStore capacitor. Supplies power to the nvSRAM during power loss to store data from SRAM to nonvolatile elements.

Notes

1. Address expansion for 1-Mbit. NC pin not connected to die.
2. Left unconnected if RTC feature is not used.

Device Operation

The CY14B256KA nvSRAM is made up of two functional components paired in the same physical cell. These are a SRAM memory cell and a nonvolatile QuantumTrap cell. The SRAM memory cell operates as a standard fast static RAM. Data in the SRAM is transferred to the nonvolatile cell (the STORE operation), or from the nonvolatile cell to the SRAM (the RECALL operation). Using this unique architecture, all cells are stored and recalled in parallel. During the STORE and RECALL operations SRAM read and write operations are inhibited. The CY14B256KA supports infinite reads and writes similar to a typical SRAM. In addition, it provides infinite RECALL operations from the nonvolatile cells and up to 1 million STORE operations. Refer the [Truth Table For SRAM Operations on page 23](#) for a complete description of read and write modes.

SRAM Read

The CY14B256KA performs a read cycle whenever \overline{CE} and \overline{OE} are LOW, and \overline{WE} and \overline{HSB} are HIGH. The address specified on pins A_{0-14} determines which of the 32,768 data bytes are accessed. When the read is initiated by an address transition, the outputs are valid after a delay of t_{AA} (read cycle #1). If the read is initiated by \overline{CE} or \overline{OE} , the outputs are valid at t_{ACE} or at t_{DOE} , whichever is later (read cycle #2). The data output repeatedly responds to address changes within the t_{AA} access time without the need for transitions on any control input pins. This remains valid until another address change or until \overline{CE} or \overline{OE} is brought HIGH, or \overline{WE} or \overline{HSB} is brought LOW.

SRAM Write

A write cycle is performed when \overline{CE} and \overline{WE} are LOW and \overline{HSB} is HIGH. The address inputs must be stable before entering the write cycle and must remain stable until \overline{CE} or \overline{WE} goes HIGH at the end of the cycle. The data on the common I/O pins IO_{0-7} are written into the memory if it is valid t_{SD} before the end of a \overline{WE} -controlled write, or before the end of an \overline{CE} -controlled write. It is recommended that \overline{OE} be kept HIGH during the entire write cycle to avoid data bus contention on common I/O lines. If \overline{OE} is left LOW, internal circuitry turns off the output buffers t_{HZWE} after \overline{WE} goes LOW.

AutoStore Operation

The CY14B256KA stores data to the nvSRAM using one of three storage operations. These three operations are: Hardware STORE, activated by the \overline{HSB} ; Software STORE, activated by an address sequence; AutoStore, on device power-down. The AutoStore operation is a unique feature of QuantumTrap technology and is enabled by default on the CY14B256KA.

During normal operation, the device draws current from V_{CC} to charge a capacitor connected to the V_{CAP} pin. This stored charge is used by the chip to perform a single STORE operation. If the voltage on the V_{CC} pin drops below V_{SWITCH} , the part automatically disconnects the V_{CAP} pin from V_{CC} . A STORE operation is initiated with power provided by the V_{CAP} capacitor.

Note If the capacitor is not connected to V_{CAP} pin, AutoStore must be disabled using the soft sequence specified in [Preventing AutoStore on page 7](#). In case AutoStore is enabled without a capacitor on V_{CAP} pin, the device attempts an AutoStore operation without sufficient charge to complete the Store. This corrupts the data stored in nvSRAM.

Figure 2. AutoStore Mode

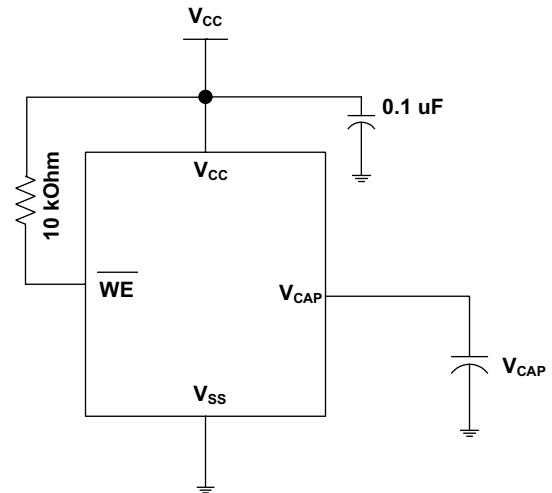

Figure 2 shows the proper connection of the storage capacitor (V_{CAP}) for automatic STORE operation. Refer to [DC Electrical Characteristics on page 15](#) for the size of the V_{CAP} . The voltage on the V_{CAP} pin is driven to V_{CC} by a regulator on the chip. Place a pull-up on \overline{WE} to hold it inactive during power-up. This pull-up is only effective if the \overline{WE} signal is tristate during power-up. Many MPUs tristate their controls on power-up. This must be verified when using the pull-up. When the nvSRAM comes out of power-on-RECALL, the MPU must be active or the \overline{WE} held inactive until the MPU comes out of reset.

To reduce unnecessary nonvolatile stores, AutoStore and Hardware STORE operations are ignored unless at least one write operation has taken place since the most recent STORE or RECALL cycle. Software initiated STORE cycles are performed regardless of whether a write operation has taken place.

The \overline{HSB} signal is monitored by the system to detect if an AutoStore cycle is in progress.

Hardware STORE (\overline{HSB}) Operation

The CY14B256KA provides the \overline{HSB} pin to control and acknowledge the STORE operations. The \overline{HSB} pin is used to request a Hardware STORE cycle. When the \overline{HSB} pin is driven LOW, the CY14B256KA conditionally initiates a STORE operation after t_{DELAY} . An actual STORE cycle begins only if a write to the SRAM has taken place since the last STORE or RECALL cycle. The \overline{HSB} pin also acts as an open drain driver (internal 100 k Ω weak pull-up resistor) that is internally driven LOW to indicate a busy condition when the STORE (initiated by any means) is in progress.

Note After each Hardware and Software STORE operation \overline{HSB} is driven HIGH for a short time (t_{HHHD}) with standard output high current and then remains HIGH by internal 100 k Ω pull-up resistor.

SRAM write operations that are in progress when \overline{HSB} is driven LOW by any means are given time (t_{DELAY}) to complete before the STORE operation is initiated. However, any SRAM write cycles requested after \overline{HSB} goes LOW are inhibited until \overline{HSB} returns HIGH. In case the write latch is not set, \overline{HSB} is not driven LOW by the CY14B256KA. But any SRAM read and write cycles are inhibited until \overline{HSB} is returned HIGH by MPU or other external source.

During any STORE operation, regardless of how it is initiated, the CY14B256KA continues to drive the HSB pin LOW, releasing it only when the STORE is complete. Upon completion of the STORE operation, the nvSRAM memory access is inhibited for t_{LZHSB} time after HSB pin returns HIGH. Leave the HSB unconnected if it is not used.

Hardware RECALL (Power-Up)

During power-up or after any low power condition ($V_{CC} < V_{SWITCH}$), an internal RECALL request is latched. When V_{CC} again exceeds the V_{SWITCH} on powerup, a RECALL cycle is automatically initiated and takes $t_{HRECALL}$ to complete. During this time, the HSB pin is driven LOW by the HSB driver and all reads and writes to nvSRAM are inhibited.

Software STORE

Data is transferred from the SRAM to the nonvolatile memory by a software address sequence. The CY14B256KA Software STORE cycle is initiated by executing sequential \overline{CE} or \overline{OE} controlled read cycles from six specific address locations in exact order. During the STORE cycle, an erase of the previous nonvolatile data is first performed, followed by a program of the nonvolatile elements. After a STORE cycle is initiated, further input and output are disabled until the cycle is completed.

Because a sequence of reads from specific addresses is used for STORE initiation, it is important that no other read or write accesses intervene in the sequence, or the sequence is aborted and no STORE or RECALL takes place.

To initiate the Software STORE cycle, the following read sequence must be performed:

1. Read address 0x0E38 Valid READ
2. Read address 0x31C7 Valid READ

3. Read address 0x03E0 Valid READ
4. Read address 0x3C1F Valid READ
5. Read address 0x303F Valid READ
6. Read address 0x0FC0 Initiate STORE cycle

The software sequence may be clocked with \overline{CE} controlled reads or \overline{OE} controlled reads, with \overline{WE} kept HIGH for all the six READ sequences. After the sixth address in the sequence is entered, the STORE cycle commences and the chip is disabled. HSB is driven LOW. After the t_{STORE} cycle time is fulfilled, the SRAM is activated again for the read and write operation.

Software RECALL

Data is transferred from the nonvolatile memory to the SRAM by a software address sequence. A Software RECALL cycle is initiated with a sequence of read operations in a manner similar to the Software STORE initiation. To initiate the RECALL cycle, the following sequence of \overline{CE} or \overline{OE} controlled read operations must be performed:

1. Read address 0x0E38 Valid READ
2. Read address 0x31C7 Valid READ
3. Read address 0x03E0 Valid READ
4. Read address 0x3C1F Valid READ
5. Read address 0x303F Valid READ
6. Read address 0x0C63 Initiate RECALL cycle

Internally, RECALL is a two step procedure. First, the SRAM data is cleared. Next, the nonvolatile information is transferred into the SRAM cells. After the t_{RECALL} cycle time, the SRAM is again ready for read and write operations. The RECALL operation does not alter the data in the nonvolatile elements.

Table 1. Mode Selection

$\overline{\text{CE}}$	$\overline{\text{WE}}$	$\overline{\text{OE}}$	$\text{A}_{14}\text{-A}_0$ ^[3]	Mode	I/O	Power
H	X	X	X	Not Selected	Output High Z	Standby
L	H	L	X	Read SRAM	Output Data	Active
L	L	X	X	Write SRAM	Input Data	Active
L	H	L	0x0E38 0x31C7 0x03E0 0x3C1F 0x303F 0x0B45	Read SRAM Read SRAM Read SRAM Read SRAM Read SRAM AutoStore Disable	Output Data Output Data Output Data Output Data Output Data Output Data Output Data	Active ^[4]
L	H	L	0x0E38 0x31C7 0x03E0 0x3C1F 0x303F 0x0B46	Read SRAM Read SRAM Read SRAM Read SRAM Read SRAM AutoStore Enable	Output Data Output Data Output Data Output Data Output Data Output Data	Active ^[4]
L	H	L	0x0E38 0x31C7 0x03E0 0x3C1F 0x303F 0x0FC0	Read SRAM Read SRAM Read SRAM Read SRAM Read SRAM Nonvolatile STORE	Output Data Output Data Output Data Output Data Output Data Output High Z	Active I _{CC2} ^[4]
L	H	L	0x0E38 0x31C7 0x03E0 0x3C1F 0x303F 0x0C63	Read SRAM Read SRAM Read SRAM Read SRAM Read SRAM Nonvolatile RECALL	Output Data Output Data Output Data Output Data Output Data Output High Z	Active ^[4]

Notes

3. While there are 15 address lines on the CY14B256KA, only the lower 14 are used to control software modes.
4. The six consecutive address locations must be in the order listed. WE must be HIGH during all six cycles to enable a nonvolatile cycle.

Preventing AutoStore

The AutoStore function is disabled by initiating an AutoStore disable sequence. A sequence of read operations is performed in a manner similar to the Software STORE initiation. To initiate the AutoStore disable sequence, the following sequence of \overline{CE} or \overline{OE} controlled read operations must be performed:

1. Read address 0x0E38 Valid READ
2. Read address 0x31C7 Valid READ
3. Read address 0x03E0 Valid READ
4. Read address 0x3C1F Valid READ
5. Read address 0x303F Valid READ
6. Read address 0x0B45 AutoStore Disable

The AutoStore is reenabled by initiating an AutoStore enable sequence. A sequence of read operations is performed in a manner similar to the Software RECALL initiation.

To initiate the AutoStore enable sequence, the following sequence of \overline{CE} or \overline{OE} controlled read operations must be performed:

1. Read address 0x0E38 Valid READ
2. Read address 0x31C7 Valid READ
3. Read address 0x03E0 Valid READ
4. Read address 0x3C1F Valid READ
5. Read address 0x303F Valid READ
6. Read address 0x0B46 AutoStore Enable

If the AutoStore function is disabled or re-enabled, a manual STORE operation (Hardware or Software) issued to save the AutoStore state through subsequent power-down cycles. The part comes from the factory with AutoStore enabled and 0x00 written in all cells.

Data Protection

The CY14B256KA protects data from corruption during low voltage conditions by inhibiting all externally initiated STORE and write operations. The low voltage condition is detected when V_{CC} is less than V_{SWITCH} . If the CY14B256KA is in a write mode (both \overline{CE} and \overline{WE} are LOW) at power-up, after a RECALL or STORE, the write is inhibited until the SRAM is enabled after t_{LZHSB} (HSB to output active). This protects against inadvertent writes during power-up or brown out conditions.

Real Time Clock Operation

nvTIME Operation

The CY14B256KA offers internal registers that contain clock, alarm, watchdog, interrupt, and control functions. RTC registers use the last 16 address locations of the SRAM. Internal double buffering of the clock and timer information registers prevents accessing transitional internal clock data during a read or write operation. Double buffering also circumvents disrupting normal timing counts or the clock accuracy of the internal clock when accessing clock data. Clock and alarm registers store data in BCD format.

RTC functionality is described in the following sections. The RTC register addresses for CY14B256KA range from 0x7FF0 to 0x7FFF. Refer to [Table 3 on page 11](#) and [Table 4 on page 12](#) for a detailed Register Map description.

Clock Operations

The clock registers maintain time up to 9,999 years in one-second increments. The time can be set to any calendar time and the clock automatically keeps track of days of the week and month, leap years, and century transitions. There are eight registers dedicated to the clock functions, which are used to set time with a write cycle and to read time with a read cycle. These registers contain the time of day in BCD format. Bits defined as '0' are currently not used and are reserved for future use by Cypress.

Reading the Clock

The double buffered RTC register structure reduces the chance of reading incorrect data from the clock. Internal updates to the CY14B256KA time keeping registers are stopped when the read bit 'R' (in the flags register at 0x7FF0) is set to '1' before reading clock data to prevent reading of data in transition. Stopping the register updates does not affect clock accuracy.

When a read sequence of RTC device is initiated, the update of the user timekeeping registers stops and does not restart until a '0' is written to the read bit 'R' (in the flags register at 0x7FF0). After the end of read sequence, all the RTC registers are simultaneously updated within 20 ms.

Setting the Clock

A write access to the RTC device stops updates to the time keeping registers and enables the time to be set when the write bit 'W' (in the flags register at 0x7FF0) is set to '1'. The correct day, date, and time is then written into the registers and must be in 24 hour BCD format. The time written is referred to as the "Base Time". This value is stored in nonvolatile registers and used in the calculation of the current time. When the write bit 'W' is cleared by writing '0' to it, the values of timekeeping registers are transferred to the actual clock counters after which the clock resumes normal operation.

If the time written to the timekeeping registers is not in the correct BCD format, each invalid nibble of the RTC registers continue counting to 0xF before rolling over to 0x0 after which RTC resumes normal operation.

Note After 'W' bit is set to '0', values written into the timekeeping, alarm, calibration, and interrupt registers are transferred to the RTC time keeping counters in t_{RTCD} time. These counter values must be saved to nonvolatile memory either by initiating a Software/Hardware STORE or AutoStore operation. While working in AutoStore disabled mode, perform a STORE operation after t_{RTCD} time while writing into the RTC registers for the modifications to be correctly recorded.

Backup Power

The RTC in the CY14B256KA is intended for permanently powered operation. The V_{RTCcap} or V_{RTCbat} pin is connected depending on whether a capacitor or battery is chosen for the application. When the primary power, V_{CC} , fails and drops below V_{SWITCH} the device switches to the backup power supply.

The clock oscillator uses very little current, which maximizes the backup time available from the backup source. Regardless of the clock operation with the primary source removed, the data stored in the nvSRAM is secure, having been stored in the nonvolatile elements when power was lost.

During backup operation, the CY14B256KA consumes a 0.35 μA (Typ) at room temperature. The user must choose capacitor or battery values according to the application.

Backup time values based on maximum current specifications are shown in the following Table 2. Nominal backup times are approximately two times longer.

Table 2. RTC Backup Time

Capacitor Value	Backup Time
0.1 F	72 hours
0.47 F	14 days
1.0 F	30 days

Using a capacitor has the obvious advantage of recharging the backup source each time the system is powered up. If a battery is used, a 3 V lithium is recommended and the CY14B256KA sources current only from the battery when the primary power is removed. However, the battery is not recharged at any time by the CY14B256KA. The battery capacity must be chosen for total anticipated cumulative down time required over the life of the system.

Stopping and Starting the Oscillator

The OSCEN bit in the calibration register at 0x7FF8 controls the enable and disable of the oscillator. This bit is nonvolatile and is shipped to customers in the “enabled” (set to ‘0’) state. To preserve the battery life when the system is in storage, OSCEN must be set to ‘1’. This turns off the oscillator circuit, extending the battery life. If the OSCEN bit goes from disabled to enabled, it takes approximately one second (two seconds maximum) for the oscillator to start.

While system power is off, if the voltage on the backup supply (V_{RTCcap} or V_{RTCbat}) falls below their respective minimum level, the oscillator may fail. The CY14B256KA has the ability to detect oscillator failure when system power is restored. This is recorded in the Oscillator Fail Flag (OSCF) of the flags register at the address 0x7FF0. When the device is powered on (V_{CC} goes above V_{SWITCH}) the OSCEN bit is checked for the ‘enabled’ status. If the OSCEN bit is enabled and the oscillator is not active within the first 5 ms, the OSCF bit is set to ‘1’. The system must check for this condition and then write ‘0’ to clear the flag.

Note that in addition to setting the OSCF flag bit, the time registers are reset to the ‘Base Time’, which is the value last written to the timekeeping registers. The control or calibration registers and the OSCEN bit are not affected by the ‘oscillator failed’ condition.

The value of OSCF must be reset to ‘0’ when the time registers are written for the first time. This initializes the state of this bit which may have become set when the system was first powered on.

To reset OSCF, set the write bit ‘W’ (in the flags register at 0x7FF0) to a ‘1’ to enable writes to the flags register. Write a ‘0’ to the OSCF bit and then reset the write bit to ‘0’ to disable writes.

Calibrating the Clock

The RTC is driven by a quartz controlled crystal with a nominal frequency of 32.768 kHz. Clock accuracy depends on the quality of the crystal and calibration. The crystals available in market typically have an error of ± 20 ppm to ± 35 ppm. However,

CY14B256KA employs a calibration circuit that improves the accuracy to ± 1 – 2 ppm at 25 °C. This implies an error of ± 2.5 seconds to -5 seconds per month.

The calibration circuit adds or subtracts counts from the oscillator divider circuit to achieve this accuracy. The number of pulses that are suppressed (subtracted, negative calibration) or split (added, positive calibration) depends upon the value loaded into the five calibration bits found in Calibration register at 0x7FF8. The calibration bits occupy the five lower order bits in the Calibration register. These bits are set to represent any value between ‘0’ and 31 in binary form. Bit D5 is a sign bit, where a ‘1’ indicates positive calibration and a ‘0’ indicates negative calibration. Adding counts speeds the clock up and subtracting counts slows the clock down. If a binary ‘1’ is loaded into the register, it corresponds to an adjustment of 4.068 or -2.034 ppm offset in oscillator error, depending on the sign.

Calibration occurs within a 64-minute cycle. The first 62 minutes in the cycle may, once every minute, have one second shortened by 128 or lengthened by 256 oscillator cycles. If a binary ‘1’ is loaded into the register, only the first two minutes of the 64-minute cycle are modified. If a binary 6 is loaded, the first 12 are affected, and so on. Therefore, each calibration step has the effect of adding 512 or subtracting 256 oscillator cycles for every 125,829,120 actual oscillator cycles, that is, 4.068 or -2.034 ppm of adjustment per calibration step in the Calibration register.

To determine the required calibration, the CAL bit in the flags register (0x7FF0) must be set to ‘1’. This causes the INT pin to toggle at a nominal frequency of 512 Hz. Any deviation measured from the 512 Hz indicates the degree and direction of the required correction. For example, a reading of 512.01024 Hz indicates a $+20$ ppm error. Hence, a decimal value of -10 (001010b) must be loaded into the Calibration register to offset this error.

Note Setting or changing the Calibration register does not affect the test output frequency.

To set or clear CAL, set the write bit ‘W’ (in the flags register at 0x7FF0) to ‘1’ to enable writes to the flags register. Write a value to CAL, and then reset the write bit to ‘0’ to disable writes.

Alarm

The alarm function compares user programmed values of alarm time and date (stored in the registers 0x7FF1-5) with the corresponding time of day and date values. When a match occurs, the alarm internal flag (AF) is set and an interrupt is generated on INT pin if Alarm Interrupt Enable (AIE) bit is set.

There are four alarm match fields – date, hours, minutes, and seconds. Each of these fields has a match bit that is used to determine if the field is used in the alarm match logic. Setting the match bit to ‘0’ indicates that the corresponding field is used in the match process. Depending on the match bits, the alarm occurs as specifically as once a month or as frequently as once every minute. Selecting none of the match bits (all 1s) indicates that no match is required and therefore, alarm is disabled. Selecting all match bits (all 0s) causes an exact time and date match.

There are two ways to detect an alarm event: by reading the AF flag or monitoring the INT pin. The AF flag in the flags register at 0x7FF0 indicates that a date or time match has occurred. The AF bit is set to ‘1’ when a match occurs. Reading the flags

register clears the alarm flag bit (and all others). A hardware interrupt pin may also be used to detect an alarm event.

To set, clear or enable an alarm, set the 'W' bit (in flags register – 0x7FF0) to '1' to enable writes to Alarm Registers. After writing the alarm value, clear the 'W' bit back to '0' for the changes to take effect.

Note CY14B256KA requires the alarm match bit for seconds (bit 'D7' in Alarm-Seconds register 0x7FF2) to be set to '0' for proper operation of Alarm Flag and Interrupt.

Watchdog Timer

The watchdog timer is a free running down counter that uses the 32 Hz clock (31.25 ms) derived from the crystal oscillator. The oscillator must be running for the watchdog to function. It begins counting down from the value loaded in the watchdog timer register.

The timer consists of a loadable register and a free running counter. On power-up, the watchdog time out value in register 0x7FF7 is loaded into the counter load register. Counting begins on power-up and restarts from the loadable value any time the watchdog strobe (WDS) bit is set to '1'. The counter is compared to the terminal value of '0'. If the counter reaches this value, it causes an internal flag and an optional interrupt output. You can prevent the time out interrupt by setting WDS bit to '1' prior to the counter reaching '0'. This causes the counter to reload with the watchdog time out value and to be restarted. As long as the user sets the WDS bit prior to the counter reaching the terminal value, the interrupt and WDT flag never occur.

New time out values are written by setting the watchdog write bit to '0'. When the WDW is '0', new writes to the watchdog time out value bits D5–D0 are enabled to modify the time out value. When WDW is '1', writes to bits D5–D0 are ignored. The WDW function enables a user to set the WDS bit without concern that the watchdog timer value is modified. A logical diagram of the watchdog timer is shown in Figure 3. Note that setting the watchdog time out value to '0' disables the watchdog function.

The output of the watchdog timer is the flag bit WDF that is set if the watchdog is allowed to time out. If the watchdog interrupt enable (WIE) bit in the interrupt register is set, a hardware interrupt on INT pin is also generated on watchdog timeout. The flag and the hardware interrupt are both cleared when user reads the flags register.

Figure 3. Watchdog Timer Block Diagram

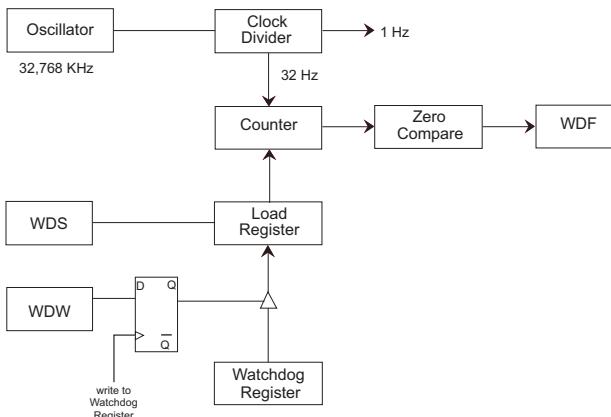

Power Monitor

The CY14B256KA provides a power management scheme with power fail interrupt capability. It also controls the internal switch to backup power for the clock and protects the memory from low V_{CC} access. The power monitor is based on an internal band gap reference circuit that compares the V_{CC} voltage to V_{SWITCH} threshold.

As described in the [AutoStore Operation on page 4](#), when V_{SWITCH} is reached as V_{CC} decays from power loss, a data STORE operation is initiated from SRAM to the nonvolatile elements, securing the last SRAM data state. Power is also switched from V_{CC} to the backup supply (battery or capacitor) to operate the RTC oscillator.

When operating from the backup source, read and write operations to nvSRAM are inhibited and the RTC functions are not available to the user. The RTC clock continues to operate in the background. The updated RTC time keeping registers data are available to the user after V_{CC} is restored to the device (see [AutoStore/Power-Up RECALL on page 20](#)).

Interrupts

The CY14B256KA has flags register, interrupt register and interrupt logic that can signal interrupt to the microcontroller. There are three potential sources for interrupt: watchdog timer, power monitor, and alarm timer. Each of these can be individually enabled to drive the INT pin by appropriate setting in the interrupt register (0x7FF6). In addition, each has an associated flag bit in the flags register (0x7FF0) that the host processor uses to determine the cause of the interrupt. The INT pin driver has two bits that specify its behavior when an interrupt occurs.

An interrupt is raised only if both a flag is raised by one of the three sources and the respective interrupt enable bit in interrupts register is enabled (set to '1'). After an interrupt source is active, two programmable bits, H/L and P/L, determine the behavior of the output pin driver on INT pin. These two bits are located in the interrupt register and can be used to drive level or pulse mode output from the INT pin. In pulse mode, the pulse width is internally fixed at approximately 200 ms. This mode is intended to reset a host microcontroller. In the level mode, the pin goes to its active polarity until the flags register is read by the user. This mode is used as an interrupt to a host microcontroller. The control bits are summarized in the following section.

Interrupts are only generated while working on normal power and are not triggered when system is running in backup power mode.

Note CY14B256KA generates valid interrupts only after the Powerup RECALL sequence is completed. All events on INT pin must be ignored for t_{HRECALL} duration after powerup.

Interrupt Register

Watchdog Interrupt Enable (WIE). When set to '1', the watchdog timer drives the INT pin and an internal flag when a watchdog time out occurs. When WIE is set to '0', the watchdog timer only affects the WDF flag in flags register.

Alarm Interrupt Enable (AIE). When set to '1', the alarm match drives the INT pin and an internal flag. When AIE is set to '0', the alarm match only affects the AF flag in flags register.

Power Fail Interrupt Enable (PFE). When set to '1', the power fail monitor drives the pin and an internal flag. When PFE is set

to '0', the power fail monitor only affects the PF flag in flags register.

High/Low (H/L). When set to a '1', the INT pin is active HIGH and the driver mode is push pull. The INT pin drives high only when V_{CC} is greater than V_{SWITCH} . When set to a '0', the INT pin is active LOW and the drive mode is open drain. The INT pin must be pulled up to V_{CC} by a 10 k resistor while using the interrupt in active LOW mode.

Pulse/Level (P/L). When set to a '1' and an interrupt occurs, the INT pin is driven for approximately 200 ms. When P/L is set to a

'0', the INT pin is driven high or low (determined by H/L) until the flags register is read.

When an enabled interrupt source activates the INT pin, an external host reads the flags register to determine the cause. All flags are cleared when the register is read. If the INT pin is programmed for level mode, then the condition clears and the INT pin returns to its inactive state. If the pin is programmed for pulse mode, then reading the flag also clears the flag and the pin. The pulse does not complete its specified duration if the flags register is read. If the INT pin is used as a host reset, then the flags register is not read during a reset.

Flags Register

The flags register has three flag bits: WDF, AF, and PF, which can be used to generate an interrupt. These flags are set by the watchdog timeout, alarm match, or power fail monitor respectively. The processor can either poll this register or enable interrupts to be informed when a flag is set. These flags are automatically reset when the register is read. The flags register is automatically loaded with the value 0x00 on power-up (except for the OSCF bit; see [Stopping and Starting the Oscillator on page 8](#)).

Figure 4. RTC Recommended Component Configuration [5]

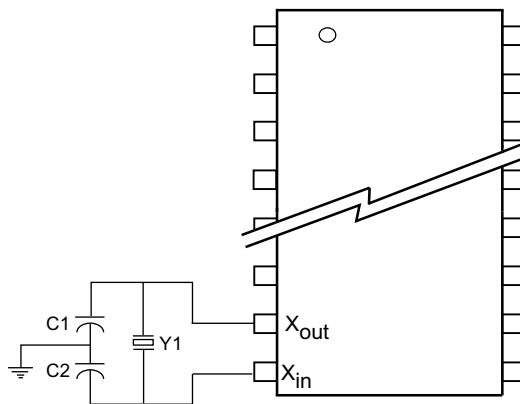

Recommended Values

$Y_1 = 32.768 \text{ kHz (12.5 pF)}$

$C_1 = 10 \text{ pF}$

$C_2 = 67 \text{ pF}$

Note: The recommended values for C1 and C2 include board trace capacitance.

Figure 5. Interrupt Block Diagram

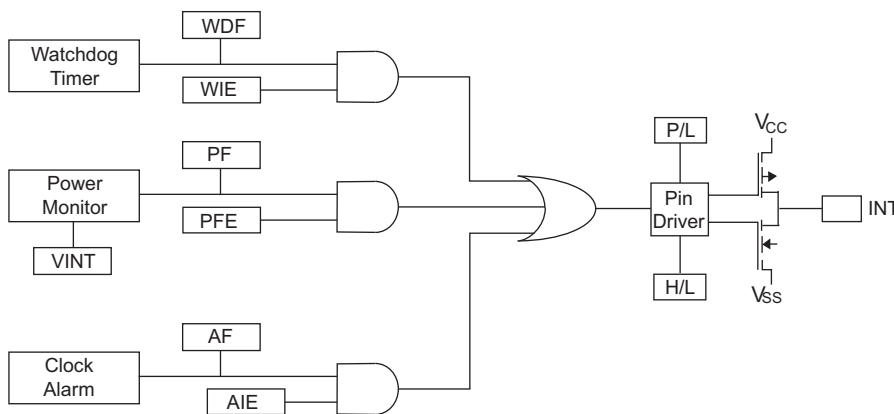

WDF - Watchdog Timer Flag
 WIE - Watchdog Interrupt Enable
 PF - Power Fail Flag
 PFE - Power Fail Enable
 AF - Alarm Flag
 AIE - Alarm Interrupt Enable
 P/L - Pulse Level
 H/L - High/Low

Note

5. For nonvolatile static random access memory (nvSRAM) real time clock (RTC) design guidelines and best practices, see application note [AN61546](#).

Table 3. RTC Register Map ^[6, 7]

Register	BCD Format Data ^[6]								Function/Range
	D7	D6	D5	D4	D3	D2	D1	D0	
0x7FFF	10s years				Years				Years: 00–99
0x7FFE	0	0	0	10s months	Months				Months: 01–12
0x7FFD	0	0	10s day of month		Day of month				Day of month: 01–31
0x7FFC	0	0	0	0	0	Day of week			Day of week: 01–07
0x7FFB	0	0	10s hours		Hours				Hours: 00–23
0x7FFA	0	10s minutes			Minutes				Minutes: 00–59
0x7FF9	0	10s seconds			Seconds				Seconds: 00–59
0x7FF8	OSCEEN (0)	0	Cal sign (0)	Calibration (00000)					Calibration values ^[8]
0x7FF7	WDS (0)	WDW (0)	WDT (000000)						Watchdog ^[8]
0x7FF6	WIE (0)	AIE (0)	PFE (0)	0	H/L (1)	P/L (0)	0	0	Interrupts ^[8]
0x7FF5	M (1)	0	10s alarm date		Alarm day				Alarm, Day of month: 01–31
0x7FF4	M (1)	0	10s alarm hours		Alarm hours				Alarm, hours: 00–23
0x7FF3	M (1)	10s alarm minutes			Alarm minutes				Alarm, minutes: 00–59
0x7FF2	M (1)	10s alarm seconds			Alarm, seconds				Alarm, seconds: 00–59
0x7FF1	10s centuries				Centuries				Centuries: 00–99
0x7FF0	WDF	AF	PF	OSCF ^[9]	0	CAL (0)	W (0)	R (0)	Flags ^[8]

Notes

- 6. The unused bits of RTC registers are reserved for future use and should be set to '0'.
- 7. () designates values shipped from the factory.
- 8. This is a binary value, not a BCD value.
- 9. When the user resets OSCF flag bit, the flags register will be updated after t_{RTC0} time.

Table 4. Register Map Detail

Register	Description							
CY14B256KA								
0x7FFF	Time Keeping - Years							
	D7	D6	D5	D4	D3	D2	D1	D0
	10s years				Years			
	Contains the lower two BCD digits of the year. Lower nibble (four bits) contains the value for years; upper nibble (four bits) contains the value for 10s of years. Each nibble operates from 0 to 9. The range for the register is 0–99.							
0x7FFE	Time Keeping - Months							
	D7	D6	D5	D4	D3	D2	D1	D0
	0	0	0	10s month	Months			
	Contains the BCD digits of the month. Lower nibble (four bits) contains the lower digit and operates from 0 to 9; upper nibble (one bit) contains the upper digit and operates from 0 to 1. The range for the register is 1–12.							
0x7FFD	Time Keeping - Date							
	D7	D6	D5	D4	D3	D2	D1	D0
	0	0	10s day of month		Day of month			
	Contains the BCD digits for the date of the month. Lower nibble (four bits) contains the lower digit and operates from 0 to 9; upper nibble (two bits) contains the 10s digit and operates from 0 to 3. The range for the register is 1–31. Leap years are automatically adjusted for.							
0x7FFC	Time Keeping - Day							
	D7	D6	D5	D4	D3	D2	D1	D0
	0	0	0	0	0	Day of week		
	Lower nibble (three bits) contains a value that correlates to day of the week. Day of the week is a ring counter that counts from 1 to 7 then returns to 1. The user must assign meaning to the day value, because the day is not integrated with the date.							
0x7FFB	Time Keeping - Hours							
	D7	D6	D5	D4	D3	D2	D1	D0
	0	0	10s hours		Hours			
	Contains the BCD value of hours in 24 hour format. Lower nibble (four bits) contains the lower digit and operates from 0 to 9; upper nibble (two bits) contains the upper digit and operates from 0 to 2. The range for the register is 0–23.							
0x7FFA	Time Keeping - Minutes							
	D7	D6	D5	D4	D3	D2	D1	D0
	0	10s minutes			Minutes			
	Contains the BCD value of minutes. Lower nibble (four bits) contains the lower digit and operates from 0 to 9; upper nibble (three bits) contains the upper minutes digit and operates from 0 to 5. The range for the register is 0–59.							
0x7FF9	Time Keeping - Seconds							
	D7	D6	D5	D4	D3	D2	D1	D0
	0	10s seconds			Seconds			
	Contains the BCD value of seconds. Lower nibble (four bits) contains the lower digit and operates from 0 to 9; upper nibble (three bits) contains the upper digit and operates from 0 to 5. The range for the register is 0–59.							

Table 4. Register Map Detail (continued)

Register	Description							
CY14B256KA								
0x7FF8	Calibration/Control							
	D7	D6	D5	D4	D3	D2	D1	D0
	OSCEN	0	Calibration sign	Calibration				
OSCEN	Oscillator Enable. When set to '1', the oscillator is stopped. When set to '0', the oscillator runs. Disabling the oscillator saves battery or capacitor power during storage.							
Calibration Sign	Determines if the calibration adjustment is applied as an addition (1) to or as a subtraction (0) from the time-base.							
Calibration	These five bits control the calibration of the clock.							
0x7FF7	WatchDog Timer							
	D7	D6	D5	D4	D3	D2	D1	D0
	WDS	WDW	WDT					
WDS	Watchdog strobe. Setting this bit to '1' reloads and restarts the watchdog timer. Setting the bit to '0' has no effect. The bit is cleared automatically after the watchdog timer is reset. The WDS bit is write only. Reading it always returns a 0.							
WDW	Watchdog write enable. Setting this bit to '1' disables any WRITE to the watchdog timeout value (D5–D0). This allows the user to set the watchdog strobe bit without disturbing the timeout value. Setting this bit to '0' allows bits D5–D0 to be written to the watchdog register when the next write cycle is complete. This function is explained in more detail in Watchdog Timer on page 9 .							
WDT	Watchdog timeout selection. The watchdog timer interval is selected by the 6-bit value in this register. It represents a multiplier of the 32 Hz count (31.25 ms). The range of timeout value is 31.25 ms (a setting of 1) to 2 seconds (setting of 3 Fh). Setting the watchdog timer register to 0 disables the timer. These bits can be written only if the WDW bit was set to 0 on a previous cycle.							
0x7FF6	Interrupt Status/Control							
	D7	D6	D5	D4	D3	D2	D1	D0
	WIE	AIE	PFE	0	H/L	P/L	0	0
WIE	Watchdog interrupt enable. When set to '1' and a watchdog timeout occurs, the watchdog timer drives the INT pin and the WDF flag. When set to '0', the watchdog timeout affects only the WDF flag.							
AIE	Alarm interrupt enable. When set to '1', the alarm match drives the INT pin and the AF flag. When set to '0', the alarm match only affects the AF flag.							
PFE	Power fail enable. When set to '1', the power fail monitor drives the INT pin and the PF flag. When set to '0', the power fail monitor affects only the PF flag.							
0	Reserved for future use							
H/L	High/Low. When set to '1', the INT pin is driven active HIGH. When set to '0', the INT pin is open drain, active LOW.							
P/L	Pulse/Level. When set to '1', the INT pin is driven active (determined by H/L) by an interrupt source for approximately 200 ms. When set to '0', the INT pin is driven to an active level (as set by H/L) until the flags register is read.							
0x7FF5	Alarm - Day							
	D7	D6	D5	D4	D3	D2	D1	D0
	M	0	10s alarm date		Alarm date			
	Contains the alarm value for the date of the month and the mask bit to select or deselect the date value.							
M	Match. When this bit is set to '0', the date value is used in the alarm match. Setting this bit to '1' causes the match circuit to ignore the date value.							

Table 4. Register Map Detail (continued)

Register	Description							
CY14B256KA								
0x7FF4	Alarm - Hours							
	D7	D6	D5	D4	D3	D2	D1	D0
	M	0	10s alarm hours		Alarm hours			
	Contains the alarm value for the hours and the mask bit to select or deselect the hours value.							
M	Match. When this bit is set to '0', the hours value is used in the alarm match. Setting this bit to '1' causes the match circuit to ignore the hours value.							
0x7FF3	Alarm - Minutes							
	D7	D6	D5	D4	D3	D2	D1	D0
	M	10s alarm minutes			Alarm minutes			
	Contains the alarm value for the minutes and the mask bit to select or deselect the minutes value.							
M	Match. When this bit is set to '0', the minutes value is used in the alarm match. Setting this bit to '1' causes the match circuit to ignore the minutes value.							
0x7FF2	Alarm - Seconds							
	D7	D6	D5	D4	D3	D2	D1	D0
	M	10s alarm seconds			Alarm seconds			
	Contains the alarm value for the seconds and the mask bit to select or deselect the seconds' value.							
M	Match. When this bit is set to '0', the seconds value is used in the alarm match. Setting this bit to '1' causes the match circuit to ignore the seconds value.							
0x7FF1	Time Keeping - Centuries							
	D7	D6	D5	D4	D3	D2	D1	D0
	10s centuries				Centuries			
	Contains the BCD value of centuries. Lower nibble (four bits) contains the lower digit and operates from 0 to 9; upper nibble (four bits) contains the upper digit and operates from 0 to 9. The range for the register is 0–99 centuries.							
0x7FF0	Flags							
	D7	D6	D5	D4	D3	D2	D1	D0
	WDF	AF	PF	OSCF	0	CAL	W	R
WDF	Watchdog timer flag. This read only bit is set to '1' when the watchdog timer is allowed to reach 0 without being reset by the user. It is cleared to '0' when the flags register is read or on power-up.							
AF	Alarm flag. This read only bit is set to '1' when the time and date match the values stored in the alarm registers with the match bits = 0. It is cleared when the flags register is read or on power-up.							
PF	Power fail flag. This read only bit is set to 1 when power falls below the power fail threshold V_{SWITCH} . It is cleared to 0 when the flags register is read or on power-up.							
OSCF	Oscillator fail flag. Set to '1' on power-up if the oscillator is enabled and not running in the first 5 ms of operation. This indicates that RTC backup power failed and clock value is no longer valid. This bit survives the power cycle and is never cleared internally by the chip. The user must check for this condition and write '0' to clear this flag. When user resets OSCF flag bit, the bit will be updated after t_{RTCp} time.							
CAL	Calibration mode. When set to '1', a 512 Hz square wave is output on the INT pin. When set to '0', the INT pin resumes normal operation. This bit defaults to 0 (disabled) on power-up.							
W	Write enable: Setting the 'W' bit to '1' freezes updates of the RTC registers. The user can then write to RTC registers, alarm registers, calibration register, interrupt register and flags register. Setting the 'W' bit to '0' causes the contents of the RTC registers to be transferred to the time keeping counters if the time has changed. This transfer process takes t_{RTCp} time to complete. This bit defaults to 0 on power-up.							
R	Read enable: Setting 'R' bit to '1', stops clock updates to user RTC registers so that clock updates are not seen during the reading process. Set 'R' bit to '0' to resume clock updates to the holding register. Setting this bit does not require 'W' bit to be set to '1'. This bit defaults to 0 on power-up.							

Maximum Ratings

Exceeding maximum ratings may shorten the useful life of the device. These user guidelines are not tested.

Storage temperature -65 °C to +150 °C
Maximum accumulated storage time	
At 150 °C ambient temperature 1000 h
At 85 °C ambient temperature 20 Years
Maximum junction temperature 150 °C
Supply voltage on V_{CC} relative to V_{SS} -0.5 V to 4.1 V
Voltage applied to outputs in High Z state -0.5 V to $V_{CC} + 0.5$ V
Input voltage -0.5 V to $V_{CC} + 0.5$ V

Transient voltage (< 20 ns) on any pin to ground potential -2.0 V to $V_{CC} + 2.0$ V
Package power dissipation capability ($T_A = 25$ °C) 1.0 W
Surface mount Pb soldering temperature (3 seconds) +260 °C
DC output current (1 output at a time, 1s duration) 15 mA
Static discharge voltage (per MIL-STD-883, Method 3015) > 2001 V
Latch up current > 200 mA

Operating Range

Range	Ambient Temperature	V_{CC}
Industrial	-40 °C to +85 °C	2.7 V to 3.6 V

DC Electrical Characteristics

Over the [Operating Range](#)

Parameter	Description	Test Conditions	Min	Typ ^[10]	Max	Unit
V_{CC}	Power supply voltage		2.7	3.0	3.6	V
I_{CC1}	Average V_{CC} current	$t_{RC} = 25$ ns $t_{RC} = 45$ ns Values obtained without output loads ($I_{OUT} = 0$ mA)	-	-	70 52	mA mA
I_{CC2}	Average V_{CC} current during STORE	All inputs don't care, $V_{CC} = \text{Max}$. Average current for duration t_{STORE}	-	-	10	mA
I_{CC3} ^[10]	Average V_{CC} current at $t_{RC} = 200$ ns, $V_{CC(Typ)}$, 25 °C	All inputs cycling at CMOS levels. Values obtained without output loads ($I_{OUT} = 0$ mA).	-	35	-	mA
I_{CC4}	Average V_{CAP} current during AutoStore cycle	All inputs don't care. Average current for duration t_{STORE}	-	-	5	mA
I_{SB}	V_{CC} standby current	$CE \geq (V_{CC} - 0.2$ V). $V_{IN} \leq 0.2$ V or $\geq (V_{CC} - 0.2$ V). W bit set to '0'. Standby current level after nonvolatile cycle is complete. Inputs are static. $f = 0$ MHz.	-	-	5	mA
I_{IX} ^[11]	Input leakage current (except HSB)	$V_{CC} = \text{Max}$, $V_{SS} \leq V_{IN} \leq V_{CC}$	-1	-	+1	μ A
	Input leakage current (for HSB)	$V_{CC} = \text{Max}$, $V_{SS} \leq V_{IN} \leq V_{CC}$	-100	-	+1	μ A
I_{OZ}	Off state output leakage current	$V_{CC} = \text{Max}$, $V_{SS} \leq V_{OUT} \leq V_{CC}$, CE or $OE \geq V_{IH}$ or $WE \leq V_{IL}$	-1	-	+1	μ A
V_{IH}	Input HIGH voltage		2.0	-	$V_{CC} + 0.5$	V
V_{IL}	Input LOW voltage		$V_{SS} - 0.5$	-	0.8	V
V_{OH}	Output HIGH voltage	$I_{OUT} = -2$ mA	2.4	-	-	V
V_{OL}	Output LOW voltage	$I_{OUT} = 4$ mA	-	-	0.4	V

Notes

10. Typical values are at 25 °C, $V_{CC} = V_{CC(Typ)}$. Not 100% tested.

11. The HSB pin has $I_{OUT} = -2$ μ A for V_{OH} of 2.4 V when both active HIGH and low drivers are disabled. When they are enabled standard V_{OH} and V_{OL} are valid. This parameter is characterized but not tested.

DC Electrical Characteristics (continued)

 Over the [Operating Range](#)

Parameter	Description	Test Conditions	Min	Typ ^[10]	Max	Unit
$V_{CAP}^{[12]}$	Storage capacitor	Between V_{CAP} pin and V_{SS}	61	68	180	μF
$V_{VCAP}^{[13, 14]}$	Maximum voltage driven on V_{CAP} pin by the device	$V_{CC} = \text{Max}$	–	–	V_{CC}	V

Data Retention and Endurance

 Over the [Operating Range](#)

Parameter	Description	Min	Unit
DATA_R	Data retention	20	Years
NV_C	Nonvolatile STORE operations	1,000	K

Capacitance

Parameter ^[14]	Description	Test Conditions	Max	Unit
C_{IN}	Input capacitance (except $\overline{\text{HSB}}$)	$T_A = 25\text{ }^\circ\text{C}$, $f = 1\text{ MHz}$, $V_{CC} = V_{CC(\text{Typ})}$	7	pF
	Input capacitance (for $\overline{\text{HSB}}$)		8	pF
C_{OUT}	Output capacitance (except $\overline{\text{HSB}}$)		7	pF
	Output capacitance (for $\overline{\text{HSB}}$)		8	pF

Thermal Resistance

Parameter ^[14]	Description	Test Conditions	48-pin SSOP	Unit
Θ_{JA}	Thermal resistance (Junction to ambient)	Test conditions follow standard test methods and procedures for measuring thermal impedance, in accordance with EIA/JESD51.	37.47	$^\circ\text{C/W}$
Θ_{JC}	Thermal resistance (Junction to case)		24.71	$^\circ\text{C/W}$

Notes

12. Min V_{CAP} value guarantees that there is a sufficient charge available to complete a successful AutoStore operation. Max V_{CAP} value guarantees that the capacitor on V_{CAP} is charged to a minimum voltage during a Power-Up RECALL cycle so that an immediate power-down cycle can complete a successful AutoStore. Therefore it is always recommended to use a capacitor within the specified min and max limits. Refer application note [AN43593](#) for more details on V_{CAP} options.
13. Maximum voltage on V_{CAP} pin (V_{VCAP}) is provided for guidance when choosing the V_{CAP} capacitor. The voltage rating of the V_{CAP} capacitor across the operating temperature range should be higher than the V_{VCAP} voltage.
14. These parameters are guaranteed by design and are not tested.

AC Test Loads

Figure 6. AC Test Loads

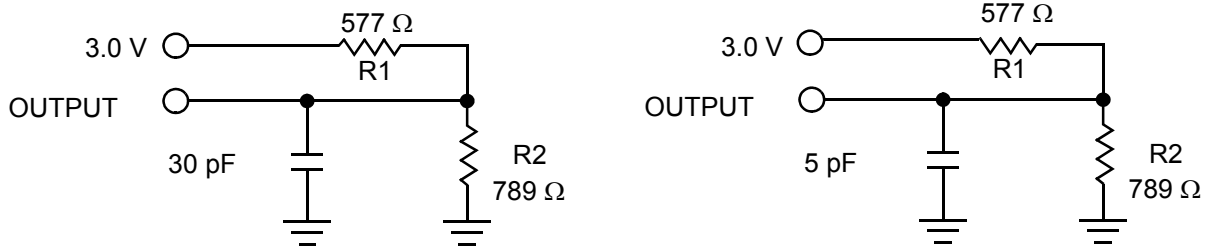

AC Test Conditions

Input pulse levels0 V to 3 V
 Input rise and fall times (10%–90%) ≤3 ns
 Input and output timing reference levels 1.5 V

RTC Characteristics

Over the [Operating Range](#)

Parameter	Description	Min	Typ ^[15]	Max	Units	
V _{RTCbat}	RTC battery pin voltage	1.8	3.0	3.6	V	
I _{BAK} ^[16]	RTC backup current	T _A (Min)	–	–	0.35	μA
		25 °C	–	0.35	–	μA
		T _A (Max)	–	–	0.5	μA
V _{RTCcap} ^[17]	RTC capacitor pin voltage	T _A (Min)	1.6	–	3.6	V
		25 °C	1.5	3.0	3.6	V
		T _A (Max)	1.4	–	3.6	V
t _{OCS}	RTC oscillator time to start	–	1	2	sec	
t _{RTCP}	RTC processing time from end of 'W' bit set to '0'	–	–	350	μs	
R _{BKCHG}	RTC backup capacitor charge current-limiting resistor	350	–	850	Ω	

Notes

15. Typical values are at 25 °C, V_{CC} = V_{CC(Typ)}. Not 100% tested.

16. From either V_{RTCcap} or V_{RTCbat}.

17. If V_{RTCcap} > 0.5 V or if no capacitor is connected to V_{RTCcap} pin, the oscillator starts in t_{OCS} time. If a backup capacitor is connected and V_{RTCcap} < 0.5 V, the capacitor must be allowed to charge to 0.5 V for oscillator to start.

AC Switching Characteristics

Over the [Operating Range](#)

Parameters ^[18]		Description	25 ns		45 ns		Unit
Cypress Parameter	Alt Parameter		Min	Max	Min	Max	
SRAM Read Cycle							
t _{ACE}	t _{ACS}	Chip enable access time	–	25	–	45	ns
t _{RC} ^[19]	t _{RC}	Read cycle time	25	–	45	–	ns
t _{AA} ^[20]	t _{AA}	Address access time	–	25	–	45	ns
t _{DOE}	t _{OE}	Output enable to data valid	–	12	–	20	ns
t _{OHA} ^[20]	t _{OH}	Output hold after address change	3	–	3	–	ns
t _{LZCE} ^[21, 22]	t _{LZ}	Chip enable to output active	3	–	3	–	ns
t _{HZCE} ^[21, 22]	t _{HZ}	Chip disable to output Inactive	–	10	–	15	ns
t _{LZOE} ^[21, 22]	t _{OLZ}	Output enable to output active	0	–	0	–	ns
t _{HZOE} ^[21, 22]	t _{OHZ}	Output disable to output inactive	–	10	–	15	ns
t _{PU} ^[21]	t _{PA}	Chip enable to power active	0	–	0	–	ns
t _{PD} ^[21]	t _{PS}	Chip disable to power standby	–	25	–	45	ns
SRAM Write Cycle							
t _{WC}	t _{WC}	Write cycle time	25	–	45	–	ns
t _{PWE}	t _{WP}	Write pulse width	20	–	30	–	ns
t _{SCE}	t _{CW}	Chip enable to end of write	20	–	30	–	ns
t _{SD}	t _{DW}	Data setup to end of write	10	–	15	–	ns
t _{HD}	t _{DH}	Data hold after end of write	0	–	0	–	ns
t _{AW}	t _{AW}	Address setup to end of write	20	–	30	–	ns
t _{SA}	t _{AS}	Address setup to start of write	0	–	0	–	ns
t _{HA}	t _{WR}	Address hold after end of write	0	–	0	–	ns
t _{HZWE} ^[21, 22, 23]	t _{WZ}	Write enable to output disable	–	10	–	15	ns
t _{LZWE} ^[21, 22]	t _{OW}	Output active after end of write	3	–	3	–	ns

Switching Waveforms

Figure 7. SRAM Read Cycle #1 (Address Controlled) ^[19, 20, 24]

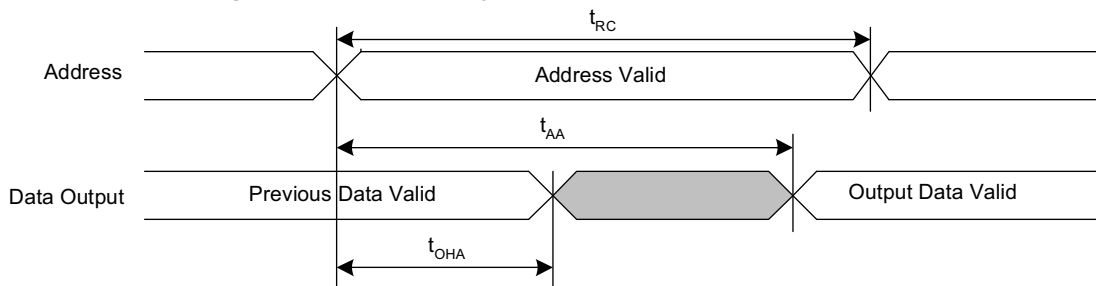

Notes

18. Test conditions assume signal transition time of 3 ns or less, timing reference levels of V_{CC}/2, input pulse levels of 0 to V_{CC}(typ), and output loading of the specified I_{OL}/I_{OH} and load capacitance shown in [Figure 6 on page 17](#).
19. WE must be HIGH during SRAM read cycles.
20. Device is continuously selected with CE and OE LOW.
21. These parameters are guaranteed by design and are not tested.
22. Measured ±200 mV from steady state output voltage.
23. If WE is low when CE goes low, the outputs remain in the high impedance state.
24. HSB must remain HIGH during Read and Write cycles.

Switching Waveforms (continued)

Figure 8. SRAM Read Cycle #2 (\overline{CE} and \overline{OE} Controlled) [25, 26]

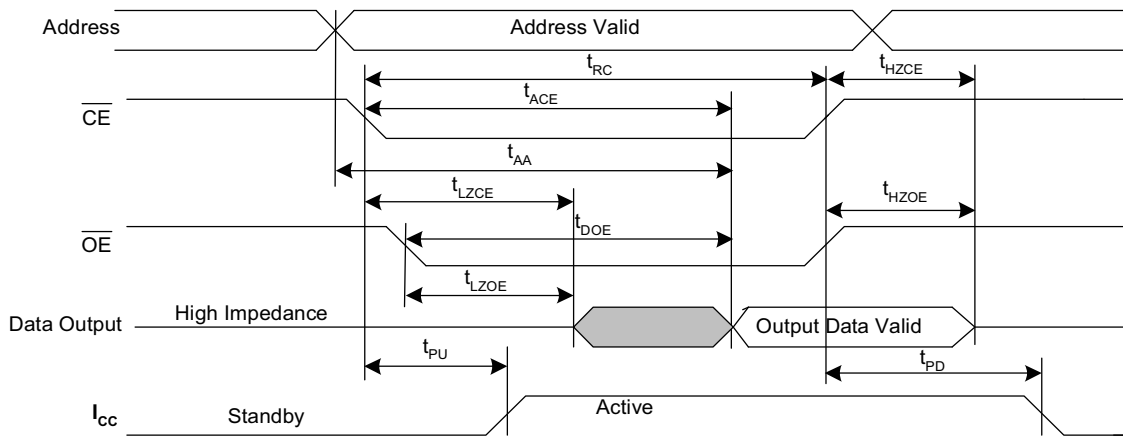

Figure 9. SRAM Write Cycle #1 (\overline{WE} Controlled) [26, 27, 28]

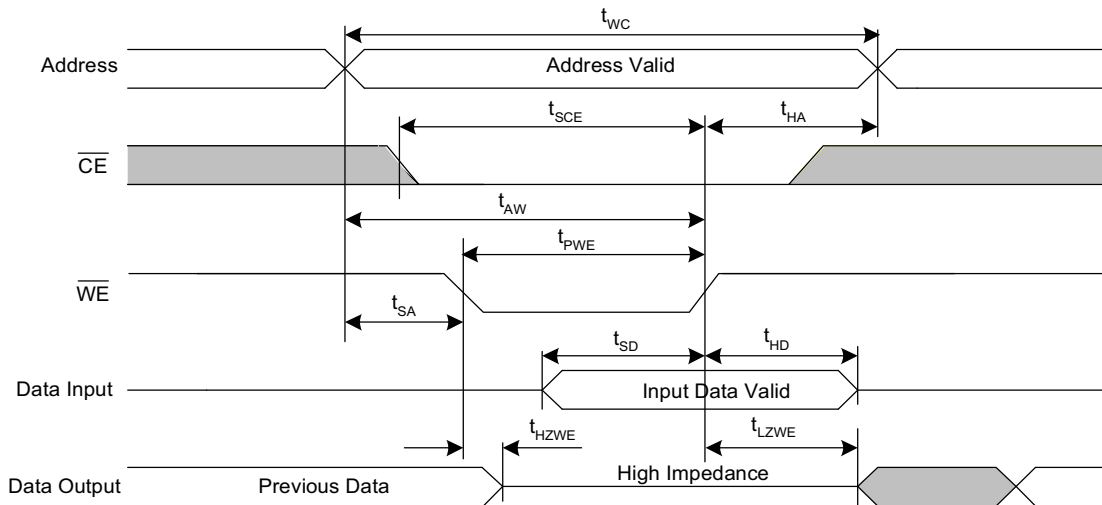
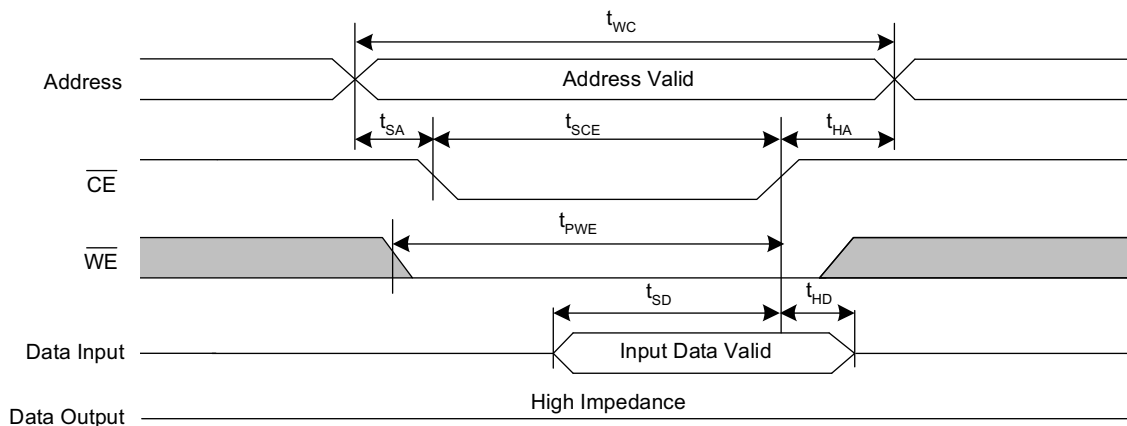

Figure 10. SRAM Write Cycle #2 (\overline{CE} Controlled) [26, 27, 28]



Notes

- 25. \overline{WE} must be HIGH during SRAM read cycles.
- 26. \overline{HSB} must remain HIGH during Read and Write cycles.
- 27. If \overline{WE} is low when \overline{CE} goes low, the outputs remain in the high impedance state.
- 28. \overline{CE} or \overline{WE} must be $\geq V_{IH}$ during address transitions.

AutoStore/Power-Up RECALL

Over the [Operating Range](#)

Parameter	Description	Min	Max	Unit
$t_{HRECALL}^{[29]}$	Power-Up RECALL duration	–	20	ms
$t_{STORE}^{[30]}$	STORE cycle duration	–	8	ms
$t_{DELAY}^{[31]}$	Time allowed to complete SRAM write cycle	–	25	ns
V_{SWITCH}	Low voltage trigger level	–	2.65	V
$t_{VCCRRISE}^{[32]}$	V_{CC} rise time	150	–	μ s
$V_{HDIS}^{[32]}$	HSB output disable voltage	–	1.9	V
$t_{LZHSB}^{[32]}$	HSB to output active time	–	5	μ s
$t_{HHHD}^{[32]}$	HSB high active time	–	500	ns

Switching Waveforms

Figure 11. AutoStore or Power-Up RECALL [33]

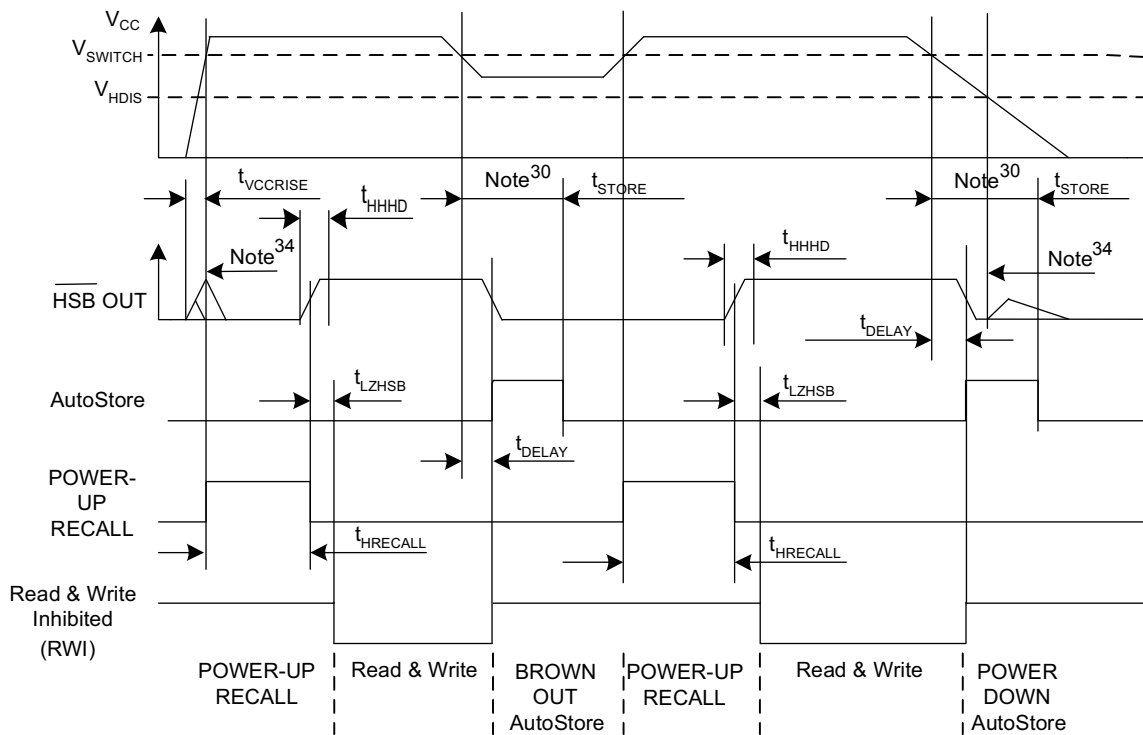

Notes

29. $t_{HRECALL}$ starts from the time V_{CC} rises above V_{SWITCH} .
30. If an SRAM write has not taken place since the last nonvolatile cycle, no AutoStore or Hardware STORE takes place.
31. On a Hardware STORE and AutoStore initiation, SRAM write operation continues to be enabled for time t_{DELAY} .
32. These parameters are guaranteed by design and are not tested.
33. Read and Write cycles are ignored during STORE, RECALL, and while V_{CC} is below V_{SWITCH} .
34. During power-up and power-down, HSB glitches when HSB pin is pulled up through an external resistor.

Software Controlled STORE/RECALL Cycle

Over the [Operating Range](#)

Parameter ^[35, 36]	Description	25 ns		45 ns		Unit
		Min	Max	Min	Max	
t_{RC}	STORE/RECALL initiation cycle time	25	–	45	–	ns
t_{SA}	Address setup time	0	–	0	–	ns
t_{CW}	Clock pulse width	20	–	30	–	ns
t_{HA}	Address hold time	0	–	0	–	ns
t_{RECALL}	RECALL duration	–	200	–	200	μ s
t_{SS} ^[37, 38]	Soft sequence processing time	–	100	–	100	μ s

Switching Waveforms

Figure 12. \overline{CE} & \overline{OE} Controlled Software STORE/RECALL Cycle ^[36]

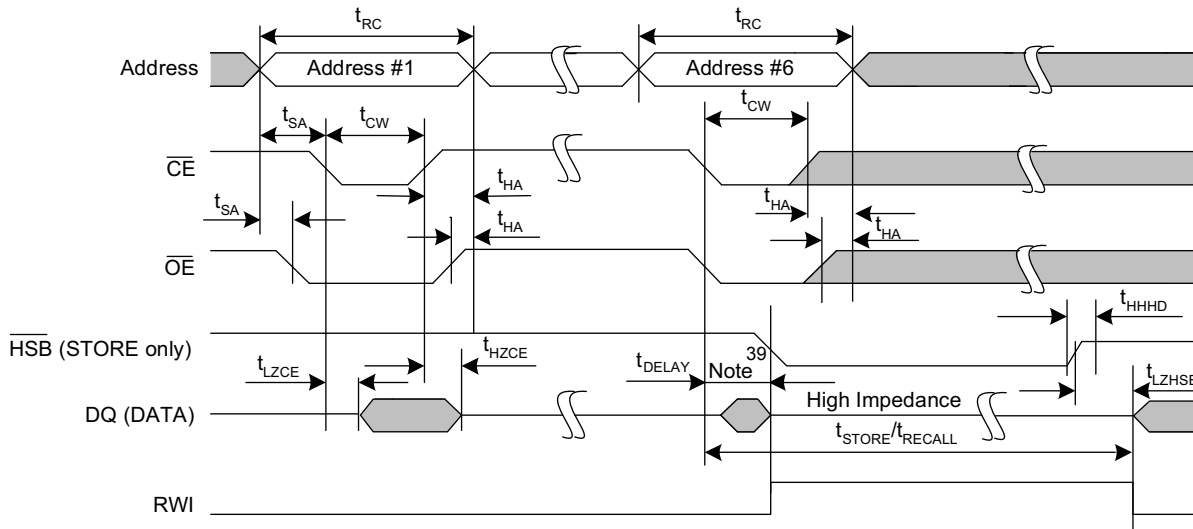
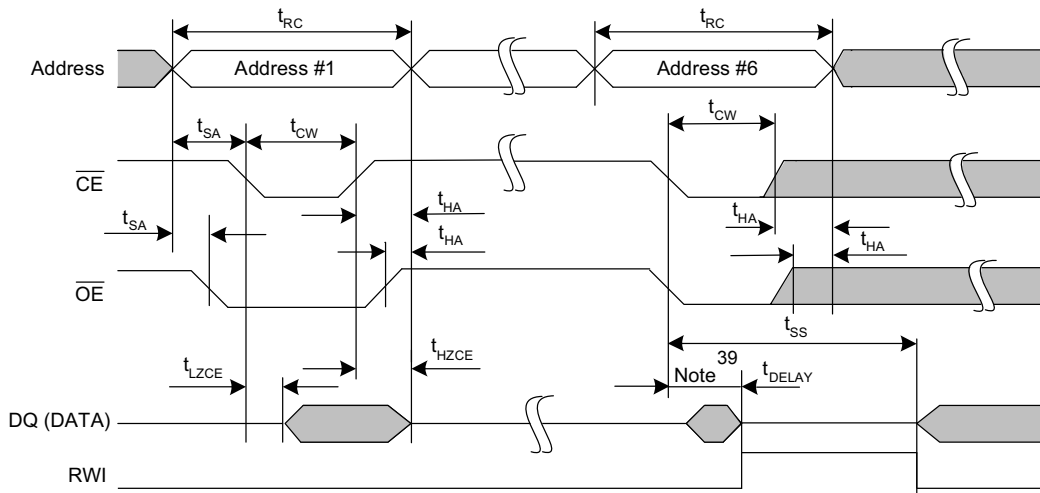

Figure 13. AutoStore Enable/Disable Cycle ^[36]



Notes

- 35. The software sequence is clocked with \overline{CE} controlled or \overline{OE} controlled reads.
- 36. The six consecutive addresses must be read in the order listed in [Table 1](#). \overline{WE} must be HIGH during all six consecutive cycles.
- 37. This is the amount of time it takes to take action on a soft sequence command. V_{CC} power must remain HIGH to effectively register command.
- 38. Commands such as STORE and RECALL lock out I/O until operation is complete which further increases this time. See the specific command.
- 39. DQ output data at the sixth read may be invalid since the output is disabled at t_{DELAY} time.

Hardware STORE Cycle

Over the [Operating Range](#)

Parameter	Description	Min	Max	Unit
t_{DHSB}	HSB to output active time when write latch not set	-	25	ns
t_{PHSB}	Hardware STORE pulse width	15	-	ns

Switching Waveforms

Figure 14. Hardware STORE Cycle [40]

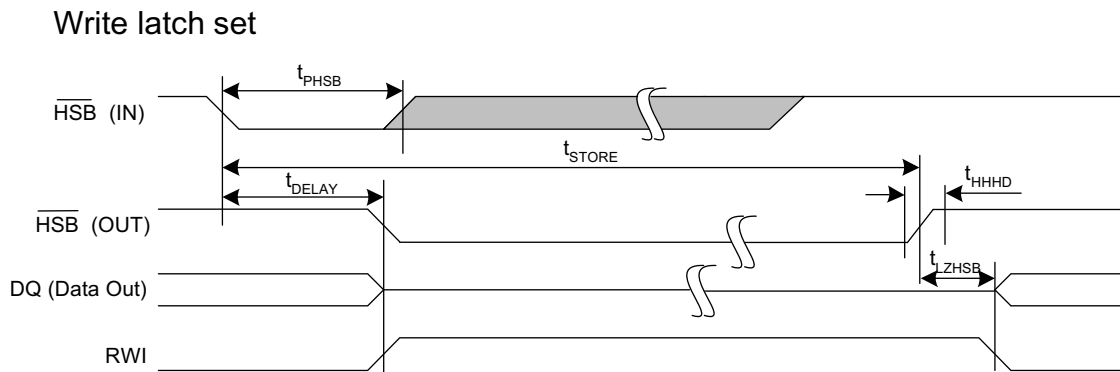

Write latch not set

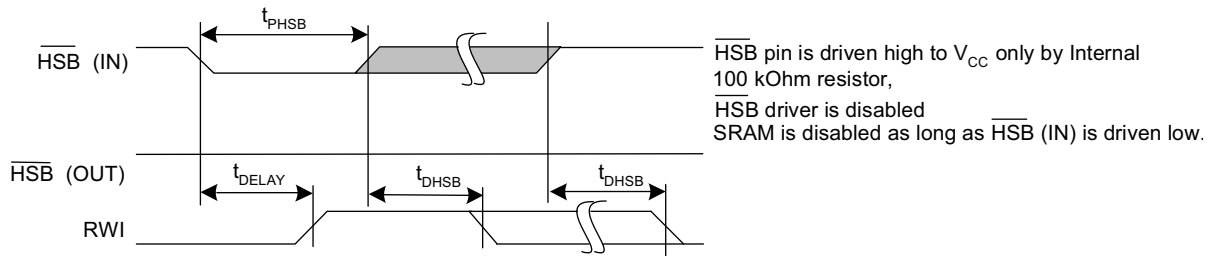
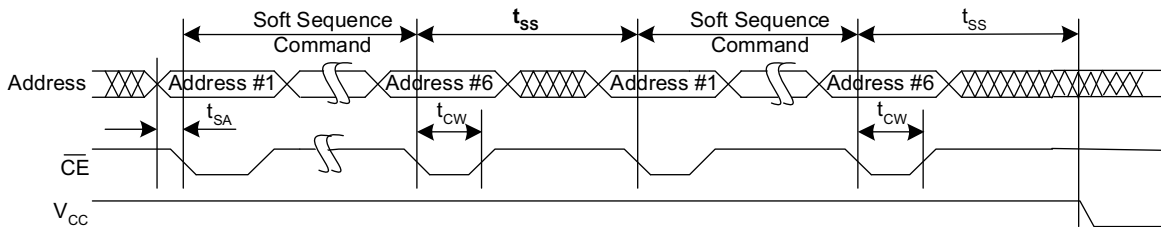

Figure 15. Soft Sequence Processing [41, 42]



Notes

- 40. If an SRAM write has not taken place since the last nonvolatile cycle, no AutoStore or Hardware STORE takes place.
- 41. This is the amount of time it takes to take action on a soft sequence command. V_{CC} power must remain HIGH to effectively register command.
- 42. Commands such as STORE and RECALL lock out I/O until operation is complete which further increases this time. See the specific command.

Truth Table For SRAM Operations

HSB must remain HIGH for SRAM operations.

Table 5. Truth Table

\overline{CE}	\overline{WE}	\overline{OE}	Inputs/Outputs	Mode	Power
H	X	X	High Z	Deselect/Power-down	Standby
L	H	L	Data out (DQ ₀ -DQ ₇)	Read	Active
L	H	H	High Z	Output disabled	Active
L	L	X	Data in (DQ ₀ -DQ ₇)	Write	Active

Ordering Information

Speed (ns)	Ordering Code	Package Diagram	Package Type	Operating Range
25	CY14B256KA-SP25XIT	51-85061	48-pin SSOP	Industrial
	CY14B256KA-SP25XI			
45	CY14B256KA-SP45XIT			
	CY14B256KA-SP45XI			

All the above parts are Pb-free.

Ordering Code Definitions

CY 14 B 256 K A - SP 25 X I T

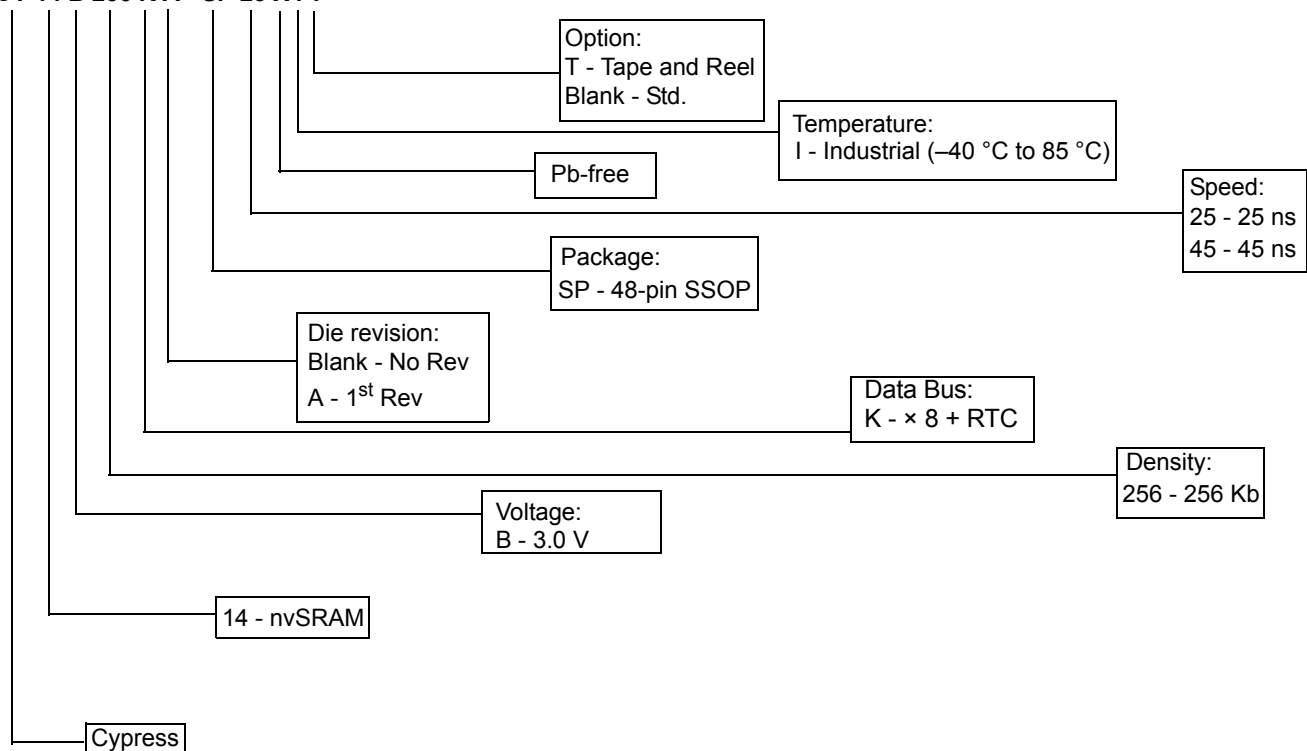

Package Diagram

Figure 16. 48-pin SSOP (300 Mils) Package Outline, 51-85061

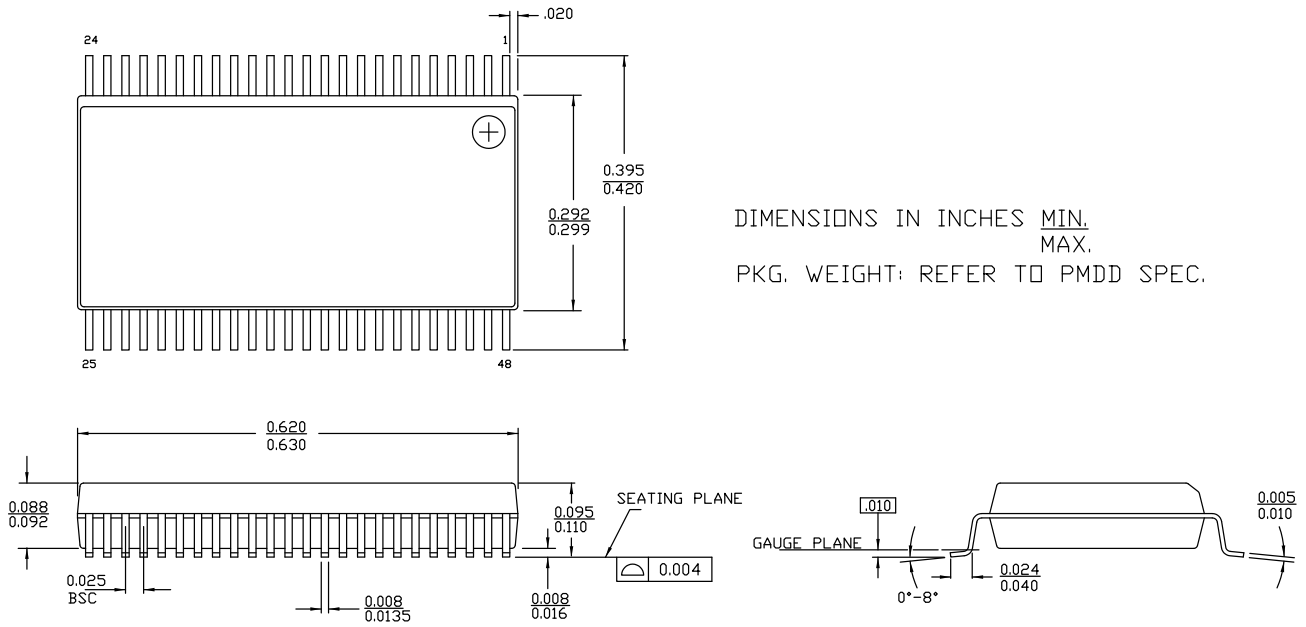

51-85061 *F

Acronyms

Acronym	Description
BCD	binary coded decimal
\overline{CE}	chip enable
CMOS	complementary metal oxide semiconductor
EIA	electronic industries alliance
\overline{HSB}	hardware store busy
I/O	input/output
nvSRAM	non-volatile static random access memory
\overline{OE}	output enable
RoHS	restriction of hazardous substances
RTC	real time clock
RWI	read and write inhibited
SRAM	static random access memory
SSOP	shrink small outline package
WE	write enable

Document Conventions

Units of Measure

Symbol	Unit of Measure
%	percent
°C	degree celsius
F	farad
Hz	hertz
kHz	kilohertz
k Ω	kiloohm
μ A	microampere
mA	milliampere
μ F	microfarad
MHz	megahertz
μ s	microsecond
ms	millisecond
ns	nanosecond
pF	picofarad
ppm	parts per million
V	volt
Ω	ohm
W	watt

Document History Page

Document Title: CY14B256KA, 256-Kbit (32 K × 8) nvSRAM with Real Time Clock				
Document Number: 001-55720				
Rev.	ECN No.	Orig. of Change	Submission Date	Description of Change
**	2763469	GVCH	09/14/09	New data sheet.
*A	2829117	GVCH	12/16/09	Added data retention and endurance table Updated STORE cycles to QuantumTrap from 200K to 1 Million Updated I _{BAK} RTC backup current spec unit from nA to μA Added Contents . Moved to external web
*B	2922858	GVCH	04/26/10	Pin Definitions : Added more clarity on HSB pin operation Hardware STORE (HSB) Operation : Added more clarity on HSB pin operation Updated HSB pin operation in Figure 11 and updated footnote 34 . Updated package diagram.
*C	3143855	GVCH	01/17/2011	Updated Setting the Clock description Added footnote 7 Updated 'W' bit description in Register Map Detail table Updated Maximum Ratings Added t _{RTCp} parameter to RTC Characteristics table Figure 11 : Typo error fixed Added Acronyms table and Units of Measure table
*D	3315247	GVCH	07/15/2011	Updated DC Electrical Characteristics (Added Note 12 and referred the same note in V _{CAP} parameter). Updated Capacitance (Included Input capacitance (for $\overline{\text{HSB}}$) and Output capacitance (for HSB)). Updated AC Switching Characteristics (Added Note 18 and referred the same note in Parameters).
*E	3587664	GVCH	04/16/2012	Updated Pin Definitions (Added Note 2 and referred the same note in V _{RTCCap} , V _{RTCbat} , Xout, Xin, INT pins). Added Note 5 and referred the same note in Figure 4 . Updated Package Diagram .
*F	3660966	GVCH	06/29/2012	Updated DC Electrical Characteristics (Added V _{V_{CAP}} parameter and its details, added Note 13 and referred the same note in V _{V_{CAP}} parameter, also referred Note 14 in V _{V_{CAP}} parameter).
*G	3759143	GVCH	09/28/2012	Updated Real Time Clock Operation (description). Updated Maximum Ratings (Removed "Ambient temperature with power applied" and included "Maximum junction temperature"). Updated Package Diagram (spec 51-85061 (Changed revision from *E to *F)).

Sales, Solutions, and Legal Information

Worldwide Sales and Design Support

Cypress maintains a worldwide network of offices, solution centers, manufacturer's representatives, and distributors. To find the office closest to you, visit us at [Cypress Locations](#).

Products

Automotive	cypress.com/go/automotive
Clocks & Buffers	cypress.com/go/clocks
Interface	cypress.com/go/interface
Lighting & Power Control	cypress.com/go/powerpsoc cypress.com/go/plc
Memory	cypress.com/go/memory
Optical & Image Sensing	cypress.com/go/image
PSoC	cypress.com/go/psoc
Touch Sensing	cypress.com/go/touch
USB Controllers	cypress.com/go/USB
Wireless/RF	cypress.com/go/wireless

PSoC Solutions

psoc.cypress.com/solutions
[PSoC 1](#) | [PSoC 3](#) | [PSoC 5](#)

© Cypress Semiconductor Corporation, 2009-2012. The information contained herein is subject to change without notice. Cypress Semiconductor Corporation assumes no responsibility for the use of any circuitry other than circuitry embodied in a Cypress product. Nor does it convey or imply any license under patent or other rights. Cypress products are not warranted nor intended to be used for medical, life support, life saving, critical control or safety applications, unless pursuant to an express written agreement with Cypress. Furthermore, Cypress does not authorize its products for use as critical components in life-support systems where a malfunction or failure may reasonably be expected to result in significant injury to the user. The inclusion of Cypress products in life-support systems application implies that the manufacturer assumes all risk of such use and in doing so indemnifies Cypress against all charges.

Any Source Code (software and/or firmware) is owned by Cypress Semiconductor Corporation (Cypress) and is protected by and subject to worldwide patent protection (United States and foreign), United States copyright laws and international treaty provisions. Cypress hereby grants to licensee a personal, non-exclusive, non-transferable license to copy, use, modify, create derivative works of, and compile the Cypress Source Code and derivative works for the sole purpose of creating custom software and or firmware in support of licensee product to be used only in conjunction with a Cypress integrated circuit as specified in the applicable agreement. Any reproduction, modification, translation, compilation, or representation of this Source Code except as specified above is prohibited without the express written permission of Cypress.

Disclaimer: CYPRESS MAKES NO WARRANTY OF ANY KIND, EXPRESS OR IMPLIED, WITH REGARD TO THIS MATERIAL, INCLUDING, BUT NOT LIMITED TO, THE IMPLIED WARRANTIES OF MERCHANTABILITY AND FITNESS FOR A PARTICULAR PURPOSE. Cypress reserves the right to make changes without further notice to the materials described herein. Cypress does not assume any liability arising out of the application or use of any product or circuit described herein. Cypress does not authorize its products for use as critical components in life-support systems where a malfunction or failure may reasonably be expected to result in significant injury to the user. The inclusion of Cypress' product in a life-support systems application implies that the manufacturer assumes all risk of such use and in doing so indemnifies Cypress against all charges.

Use may be limited by and subject to the applicable Cypress software license agreement.



Стандарт Электрон Связь

Мы молодая и активно развивающаяся компания в области поставок электронных компонентов. Мы поставляем электронные компоненты отечественного и импортного производства напрямую от производителей и с крупнейших складов мира.

Благодаря сотрудничеству с мировыми поставщиками мы осуществляем комплексные и плановые поставки широчайшего спектра электронных компонентов.

Собственная эффективная логистика и склад в обеспечивает надежную поставку продукции в точно указанные сроки по всей России.

Мы осуществляем техническую поддержку нашим клиентам и предпродажную проверку качества продукции. На все поставляемые продукты мы предоставляем гарантию .

Осуществляем поставки продукции под контролем ВП МО РФ на предприятия военно-промышленного комплекса России , а также работаем в рамках 275 ФЗ с открытием отдельных счетов в уполномоченном банке. Система менеджмента качества компании соответствует требованиям ГОСТ ISO 9001.

Минимальные сроки поставки, гибкие цены, неограниченный ассортимент и индивидуальный подход к клиентам являются основой для выстраивания долгосрочного и эффективного сотрудничества с предприятиями радиоэлектронной промышленности, предприятиями ВПК и научно-исследовательскими институтами России.

С нами вы становитесь еще успешнее!

Наши контакты:

Телефон: +7 812 627 14 35

Электронная почта: sales@st-electron.ru

Адрес: 198099, Санкт-Петербург,
Промышленная ул, дом № 19, литера Н,
помещение 100-Н Офис 331