

# **Analog 120-Pin Probing Board Manual**

**an EZ-Extender<sup>®</sup> product**

Revision 1.0, September 2013

Part Number  
82-000388-01

Analog Devices, Inc.  
One Technology Way  
Norwood, Mass. 02062-9106



## Copyright Information

©2013 Analog Devices, Inc., ALL RIGHTS RESERVED. This document may not be reproduced in any form without prior, express written consent from Analog Devices, Inc.

Printed in the USA.

## Disclaimer

Analog Devices, Inc. reserves the right to change this product without prior notice. Information furnished by Analog Devices is believed to be accurate and reliable. However, no responsibility is assumed by Analog Devices for its use; nor for any infringement of patents or other rights of third parties which may result from its use. No license is granted by implication or otherwise under the patent rights of Analog Devices, Inc.

## Trademark and Service Mark Notice

The Analog Devices logo, EngineerZone, EZ-Extender, and EZ-KIT Lite are registered trademarks of Analog Devices, Inc.

All other brand and product names are trademarks or service marks of their respective owners.

## Regulatory Compliance

The Analog 120-Pin Probing Board is designed to be used solely in a laboratory environment. The board is not intended for use as a consumer end product or as a portion of a consumer end product. The board is an open system design which does not include a shielded enclosure and therefore may cause interference to other electrical devices in close proximity. This board should not be used in or near any medical equipment or RF devices.

The Analog 120-Pin Probing Board is in the process of being certified to comply with the essential requirements of the European EMC directive 2004/108/EC and therefore carries the “CE” mark.



The probing board contains ESD (electrostatic discharge) sensitive devices. Electrostatic charges readily accumulate on the human body and equipment and can discharge without detection. Permanent damage may occur on devices subjected to high-energy discharges. Proper ESD precautions are recommended to avoid performance degradation or loss of functionality. Store unused probing boards in the protective shipping package.





# CONTENTS

## PREFACE

Product Overview .....	vii
Purpose of This Manual .....	viii
Intended Audience .....	viii
Manual Contents .....	ix
What's New in This Manual .....	ix
Technical Support .....	x
Supported Products .....	x
Product Information .....	xi
Analog Devices Web Site .....	xi
EngineerZone .....	xii
Notation Conventions .....	xii

# Contents

## USING ANALOG 120-PIN PROBING BOARD

Package Contents .....	1-1
Analog 120-Pin Probing Board Installation .....	1-2
Expansion Interface .....	1-3
Reference Design Information .....	1-4

## ANALOG 120-PIN PROBING BOARD HARDWARE REFERENCE

System Architecture .....	2-1
Connectors .....	2-2
Connector (J1) .....	2-3
Connector (P1) .....	2-3
Connector (P2–P5) .....	2-3
Connector (P7–P14) .....	2-3

## ANALOG 120-PIN PROBING BOARD BILL OF MATERIALS

## ANALOG 120-PIN PROBING BOARD SCHEMATIC

## INDEX

# PREFACE

Thank you for purchasing the Analog 120-Pin Probing Board, Analog Devices, Inc. probing board for the ADSP-CM40x family of mixed-signal control processors.

The ADSP-CM408F mixed-signal control processor is based on the ARM<sup>®</sup> Cortex<sup>®</sup>-M4 processor core and is designed for motor control and industrial applications. The probing board is shipped with all of the necessary hardware—you can start the evaluation immediately.

## Product Overview

The Analog 120-Pin Probing Board is a separately sold extender board that plugs onto the ADSP-CM403F and ADSP-CM408F EZ-KIT Lite<sup>®</sup> evaluation systems. The extender board aids the design and prototyping phases of processor-targeted applications.

The board extends the capabilities of the evaluation system by providing a point for probing any signal of the 120-pin asynchronous bus and PWM expansion interface connectors.

The board features:

- Two 120-pin connectors
  - Samtec QSH-060-01-F-D-A
  - Samtec QTH-060-01-F-D-A

## Purpose of This Manual

- Four probing headers
  - Samtec TSW-115-07-L-D
- Eight GND headers
  - FCI 90726-402HLF

For information about the hardware components of the product, refer to [Analog 120-Pin Probing Board Bill Of Materials](#).

## Purpose of This Manual

The *Analog 120-Pin Probing Board Manual* provides instructions for installing the product hardware (board). A schematic and a bill of materials are provided for reference.

## Intended Audience

The primary audience for this manual is a programmer who is familiar with an ARM Cortex-M4-based core.

The ADSP-CM40x family of mixed-signal control processors is based on the ARM Cortex-M4 processor core with floating-point unit and integrated SRAM memory, flash memory, accelerators, and peripherals.

The applicable documentation for programming the ARM Cortex-M4 processor core includes:

- *Cortex-M4 Devices Generic User Guide*
- *CoreSight ETM-M4 Technical Reference Manual*
- *Cortex-M4 Technical Reference Manual*



For additional information on this Analog Devices processor, see the *ADSP-CM40x Mixed-Signal Control Processor Hardware Reference*. This document describes the ARM Cortex-M4 processor core and memory architecture used on the ADSP-CM40x processor, but does not provide detailed programming information for the ARM core.

For more information about programming the ARM core, visit the ARM Information Center:

<http://infocenter.arm.com/help/>

## Manual Contents

The manual consists of:

- Chapter 1, [Using Analog 120-Pin Probing Board](#)  
Describes the product functionality.
- Chapter 2, [Analog 120-Pin Probing Board Hardware Reference](#)  
Provides information about the board's hardware components.
- Appendix A, [Analog 120-Pin Probing Board Bill Of Materials](#)  
Lists the hardware components used to manufacture the board.
- Appendix B, [Analog 120-Pin Probing Board Schematic](#)  
Lists the resources for board-level debugging.

## What's New in This Manual

This is the first edition (Revision 1.0) of the *Analog 120-Pin Probing Board Manual*.

# Technical Support

You can reach Analog Devices processors and DSP technical support in the following ways:

- Post your questions in the processors and DSP support community at EngineerZone®:  
<http://ez.analog.com/community/dsp>
- Submit your questions to technical support directly at:  
<http://www.analog.com/support>
- E-mail your questions about processors and processor applications to:  
[processor.support@analog.com](mailto:processor.support@analog.com) or  
[processor.china@analog.com](mailto:processor.china@analog.com) (Greater China support)
- In the **USA only**, call **1-800-ANALOGD** (1-800-262-5643)
- Contact your Analog Devices sales office or authorized distributor. Locate one at:  
[www.analog.com/adi-sales](http://www.analog.com/adi-sales)
- Send questions by mail to:  
Processors and DSP Technical Support  
Analog Devices, Inc.  
Three Technology Way  
P.O. Box 9106  
Norwood, MA 02062-9106  
USA

## Supported Products

This board supports Analog Devices ADSP-CM403F and ADSP-CM408F EZ-KIT Lites.

## Product Information

Product information can be obtained from the Analog Devices Web site and the online help system.

## Analog Devices Web Site

The Analog Devices Web site, [www.analog.com](http://www.analog.com), provides information about a broad range of products—analogue integrated circuits, amplifiers, converters, and digital signal processors.

To access a complete technical library for each processor family, go to [http://www.analog.com/processors/technical\\_library](http://www.analog.com/processors/technical_library). The manuals selection opens a list of current manuals related to the product as well as a link to the previous revisions of the manuals. When locating your manual title, note a possible errata check mark next to the title that leads to the current correction report against the manual.

Also note, [myAnalog.com](http://myAnalog.com) is a free feature of the Analog Devices Web site that allows customization of a Web page to display only the latest information about products you are interested in. You can choose to receive weekly e-mail notifications containing updates to the Web pages that meet your interests, including documentation errata against all manuals. [myAnalog.com](http://myAnalog.com) provides access to books, application notes, data sheets, code examples, and more.

Visit [myAnalog.com](http://myAnalog.com) (found on the Analog Devices home page) to sign up. If you are a registered user, just log on. Your user name is your e-mail address.

## Notation Conventions

### EngineerZone



EngineerZone is a technical support forum from Analog Devices. It allows you direct access to ADI technical support engineers. You can search FAQs and technical information to get quick answers to your embedded processing and DSP design questions.

Use EngineerZone to connect with other DSP developers who face similar design challenges. You can also use this open forum to share knowledge and collaborate with the ADI support team and your peers. Visit <http://ez.analog.com> to sign up.

## Notation Conventions

Text conventions used in this manual are identified and described as follows.

Example	Description
<b>File &gt; Close</b>	Titles in reference sections indicate the location of an item within the CCES environment's menu system (for example, the <b>Close</b> command appears on the <b>File</b> menu).
{this   that}	Alternative required items in syntax descriptions appear within curly brackets and separated by vertical bars; read the example as <i>this</i> or <i>that</i> . One or the other is required.
[this   that]	Optional items in syntax descriptions appear within brackets and separated by vertical bars; read the example as an optional <i>this</i> or <i>that</i> .
[this,...]	Optional item lists in syntax descriptions appear within brackets delimited by commas and terminated with an ellipse; read the example as an optional comma-separated list of <i>this</i> .
.SECTION	Commands, directives, keywords, and feature names are in text with letter gothic font.
<i>filename</i>	Non-keyword placeholders appear in text with italic style format.

Example	Description
	<p><b>Note:</b> For correct operation, ...</p> <p>A Note provides supplementary information on a related topic. In the online version of this book, the word <b>Note</b> appears instead of this symbol.</p>
	<p><b>Caution:</b> Incorrect device operation may result if ...</p> <p><b>Caution:</b> Device damage may result if ...</p> <p>A Caution identifies conditions or inappropriate usage of the product that could lead to undesirable results or product damage. In the online version of this book, the word <b>Caution</b> appears instead of this symbol.</p>
	<p><b>Warning:</b> Injury to device users may result if ...</p> <p>A Warning identifies conditions or inappropriate usage of the product that could lead to conditions that are potentially hazardous for the devices users. In the online version of this book, the word <b>Warning</b> appears instead of this symbol.</p>

## Notation Conventions

# 1 USING ANALOG 120-PIN PROBING BOARD

This chapter provides information about using the Analog 120-Pin Probing Board.

The following topics are covered.

- [Package Contents](#)
- [Analog 120-Pin Probing Board Installation](#)
- [Expansion Interface](#)
- [Reference Design Information](#)

For detailed information on how to program the ADSP-CM40x processors, refer to the documents listed in the [Preface](#).

For detailed information about the specific evaluation system, refer to the *ADSP-CM403F EZ-KIT Lite Evaluation System Manual* or the *ADSP-CM408F EZ-KIT Lite Evaluation System Manual*.

## Package Contents

Your Analog 120-Pin Probing Board package contains the following items:

- Analog 120-Pin Probing Board
- Hardware for securing the extender board onto the EK-KIT Lite

## Analog 120-Pin Probing Board Installation

Contact the vendor where you purchased your EZ-KIT Lite or contact Analog Devices, Inc. if any item is missing.

# Analog 120-Pin Probing Board Installation

Follow these instructions to ensure correct operation of the product hardware.

1. Attach the extender board to the EZ-KIT Lite.

The P1 connector on the extender board can be connected to the corresponding 120-pin connector on the EZ-KIT Lite.

2. Use the provided hardware to secure the extender to the EZ-KIT Lite.



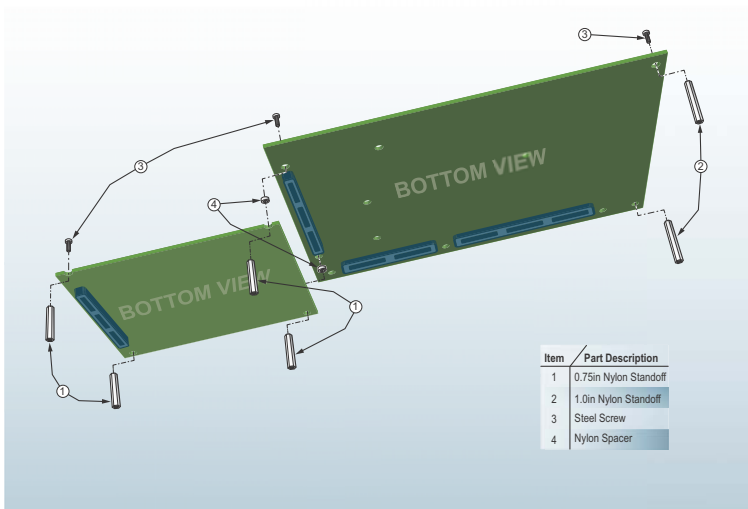

Figure 1-1. Mechanical Mating Details

**i** This image shows the PWM 180-Pin Probing Board, but this is the same attachment setup for the Analog 120-Pin Probing Board.

## Expansion Interface

The expansion interface allows a custom-designed daughter board to be tested across various hardware platforms that have the same expansion interface.

The expansion interface implemented on the ADSP-CM40x EZ-KIT Lites consists of two 180-pin connectors. The connectors contain a majority of the processor's signals. There is also a 120-pin connector for Analog signals. The Analog 120-Pin Probing Board should not be connected to the 180-pin connectors.

**⊘** Analog Devices does not support and is not responsible for the effects of additional circuitry.

# Reference Design Information

A reference design info package is available for download on the Analog Devices Web site. The package provides information on the design, layout, fabrication, and assembly of the probing board.

The information can be found at:

<http://www.analog.com/MCEI1-AnalogProbingBoard>

# 2 ANALOG 120-PIN PROBING BOARD HARDWARE REFERENCE

This chapter describes the hardware design of the Analog 120-Pin Probing Board.

The following topics are covered.

- [System Architecture](#)  
Describes the board's configuration and explains how the board components interface with the processor.
- [Connectors](#)  
Shows the locations and provides part numbers for the on-board connectors. In addition, the manufacturer and part number information is provided for the mating parts.

## System Architecture

The Analog 120-Pin Probing Board allows all signals to be probed. Silkscreen on the board corresponds with the pin number of the QTH-060-01-F-D-A (P1) connector. These numbers also match one-to-one with the QSH-060-01-F-D-A (JX) connector located on the attached EZ-KIT Lite.

It is also possible to connect the Analog 120-Pin Probing Board in between the EZ-KIT Lite and an extender card with additional circuitry. To do this, connect P1 of the extender card to the EZ-KIT Lite and attach the extender card to J1 of the Analog 120-Pin Probing Board.

## Connectors

This section describes connector functionality and provides information about mating connectors. The connector locations are shown in [Figure 2-1](#).

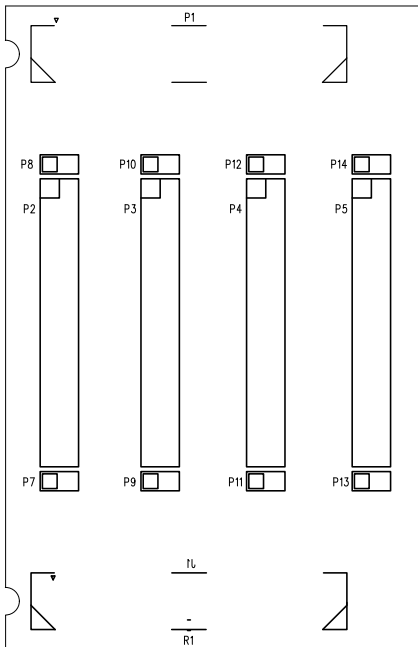

Figure 2-1. Connector Locations

## Connector (J1)

Part Description	Manufacturer	Part Number
120-pin high speed socket	SAMTEC	QSH-060-01-F-D-A
<b>Mating Connector</b>		
120-pin high speed header	SAMTEC	QTH-060-01-F-D-A

## Connector (P1)

Part Description	Manufacturer	Part Number
120-pin high speed header	SAMTEC	QTH-060-01-F-D-A
<b>Mating Connector</b>		
120-pin high speed socket	SAMTEC	QSH-060-01-F-D-A

## Connector (P2–P5)

Part Description	Manufacturer	Part Number
IDC 15x2 0.1"	SAMTEC	TSW-115-07-L-D
<b>Mating Connector</b>		
0.1" female connector with wire or oscilloscope probe		

## Connector (P7–P14)

Part Description	Manufacturer	Part Number
IDC 2x1 0.1"	FCI	90726-402HLF
<b>Mating Connector</b>		
0.1" oscilloscope probe GND		

## Connectors

# A ANALOG 120-PIN PROBING BOARD BILL OF MATERIALS

The bill of materials corresponds to [Analog 120-Pin Probing Board Schematic](#).

Ref.	Qty	Description	Reference Designator	Manufacturer	Part Number
1	8	IDC 2X1 IDC2X1	P7-P14	FCI	90726-402HLF
2	1	0.5MM 120PIN SAMTEC_ QSH-060-F-D-A	J1	SAMTEC	QSH-060-01-F-D-A
3	1	0.5MM 120PIN SAMTEC_ QTH-060-F-D-A	P1	SAMTEC	QTH-060-01-F-D-A
4	4	IDC 15X2 SAMTEC_ TSW-115-07-L-D	P2-P5	SAMTEC	TSW-115-07-L-D



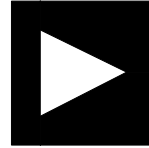

# ANALOG 120-PIN PROBING BOARD

	<b>ANALOG DEVICES</b>	20 Cotton Road Nashua, NH 03063 PH: 1-800-ANALOGD
<b>Title</b>	ANALOG 120-PIN PROBING BOARD Title	
<b>Size</b> C	<b>Board No.</b> A0388-2012	<b>Rev</b> 0.2
<b>Date</b>	01/23/2013	<b>Sheet</b> 1 <b>of</b> 2

A

B

C

D

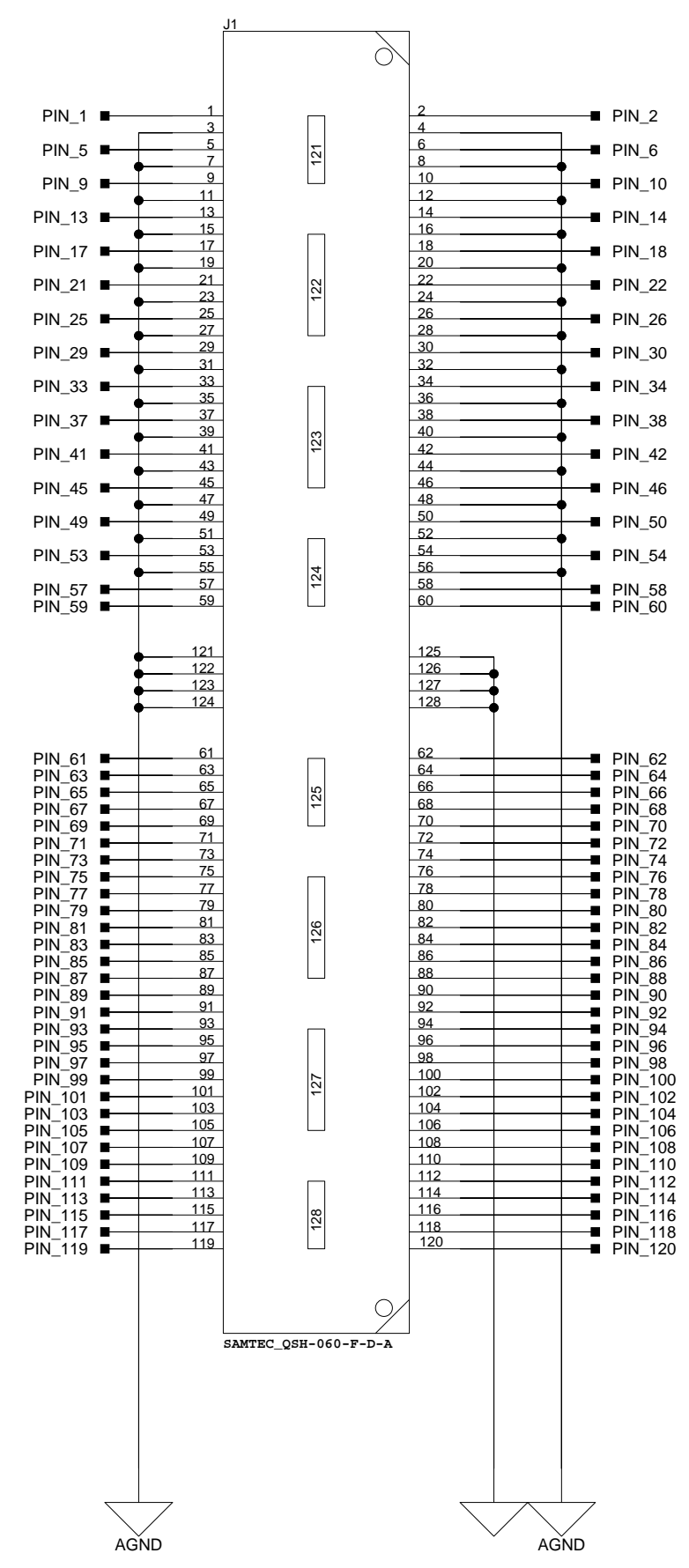
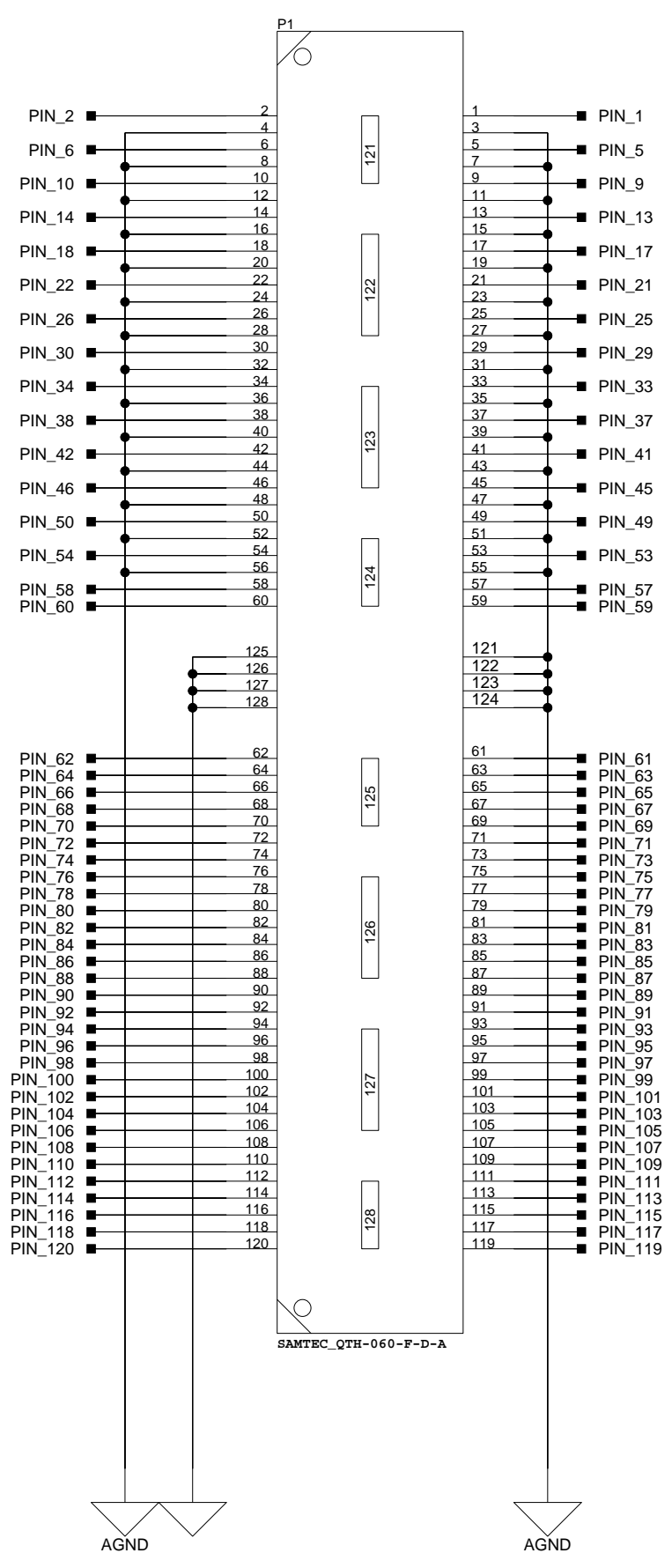
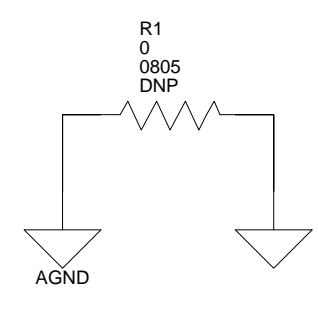
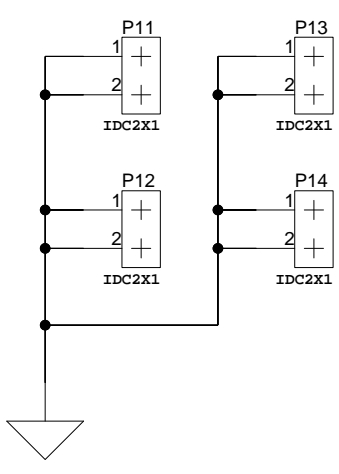
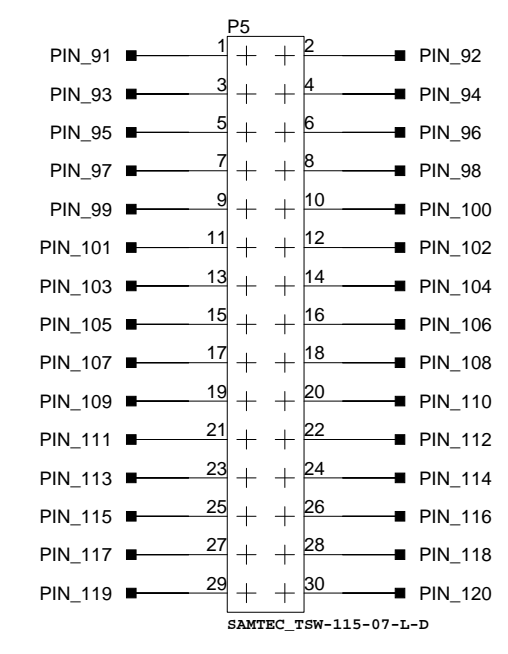
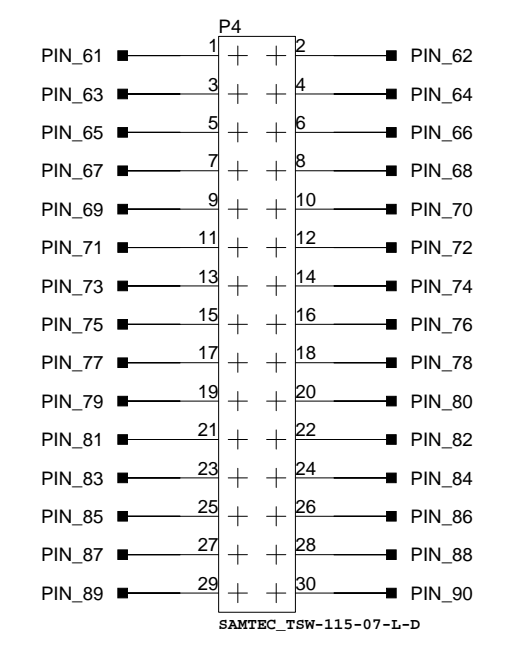
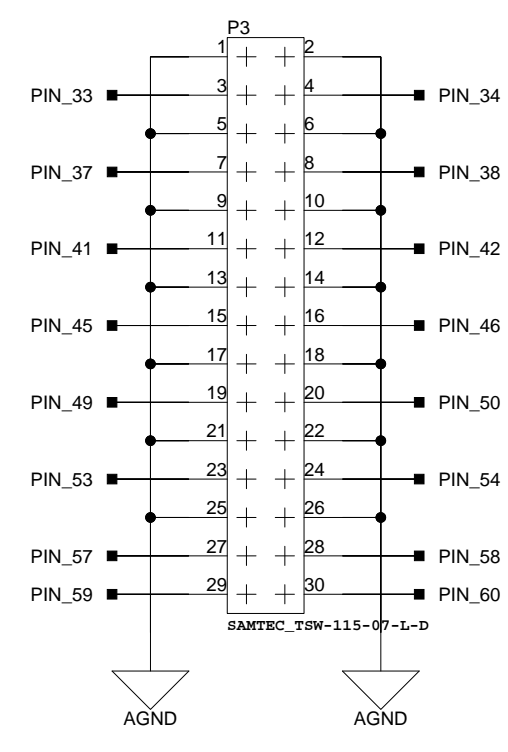
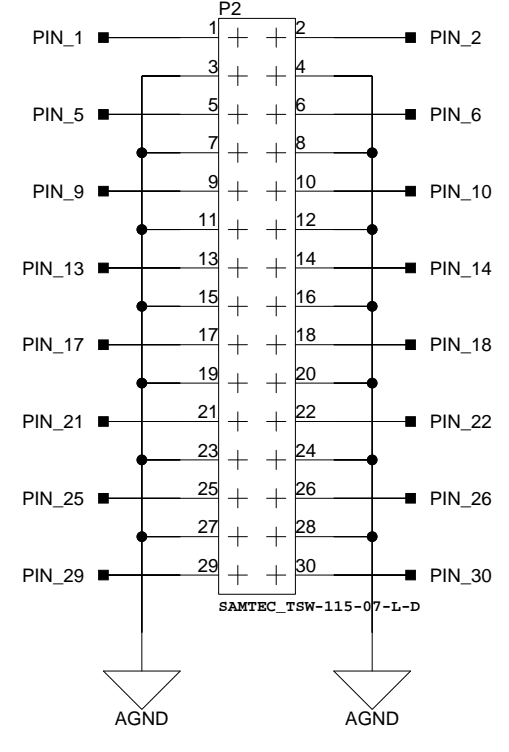
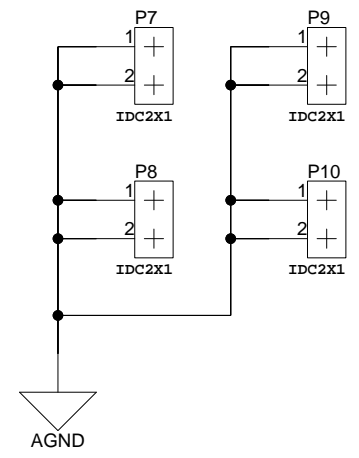

		20 Cotton Road Nashua, NH 03063 PH: 1-800-ANALOGD	
<b>Title</b> ANALOG 120-PIN PROBING BOARD Connectors			
<b>Size C</b>	<b>Board No.</b>	A0388-2012	<b>Rev</b> 0.2
<b>Date</b>	01/23/2013	<b>Sheet</b> 2	<b>of</b> 2

# I INDEX

## A

architecture, of this probing board, [2-1](#)

## B

bill of materials, [A-1](#)  
board installation, [1-2](#)  
    mechanical mating details, [1-3](#)  
board schematic, [B-1](#)

## C

connector (J1), [2-3](#)  
connectors, [2-2](#)  
    diagram of locations, [2-2](#)  
    J1, [2-3](#)  
    P1, [2-3](#)  
    P2-P5, [2-3](#)  
    P7-P14, [2-3](#)  
contents, of this probing board package,  
    [1-1](#)

## E

EngineerZone, [xii](#)  
expansion interface, [1-3](#)

## I

installation of board, [1-2](#)  
    mechanical mating details, [1-3](#)

## N

notation conventions, [xii](#)

## P

P1 connector, [2-3](#)  
P2-P5 connector, [2-3](#)  
P7-P14 connector, [2-3](#)  
package contents, [1-1](#)  
product overview, [vii](#)

## R

reference design information, [1-4](#)

## S

schematic of board, [B-1](#)  
system architecture, of this probing board,  
    [2-1](#)

## T

technical support, [x](#)

# Index



## Стандарт Электрон Связь

Мы молодая и активно развивающаяся компания в области поставок электронных компонентов. Мы поставляем электронные компоненты отечественного и импортного производства напрямую от производителей и с крупнейших складов мира.

Благодаря сотрудничеству с мировыми поставщиками мы осуществляем комплексные и плановые поставки широчайшего спектра электронных компонентов.

Собственная эффективная логистика и склад в обеспечивает надежную поставку продукции в точно указанные сроки по всей России.

Мы осуществляем техническую поддержку нашим клиентам и предпродажную проверку качества продукции. На все поставляемые продукты мы предоставляем гарантию .

Осуществляем поставки продукции под контролем ВП МО РФ на предприятия военно-промышленного комплекса России , а также работаем в рамках 275 ФЗ с открытием отдельных счетов в уполномоченном банке. Система менеджмента качества компании соответствует требованиям ГОСТ ISO 9001.

Минимальные сроки поставки, гибкие цены, неограниченный ассортимент и индивидуальный подход к клиентам являются основой для выстраивания долгосрочного и эффективного сотрудничества с предприятиями радиоэлектронной промышленности, предприятиями ВПК и научно-исследовательскими институтами России.

С нами вы становитесь еще успешнее!

### Наши контакты:

**Телефон:** +7 812 627 14 35

**Электронная почта:** [sales@st-electron.ru](mailto:sales@st-electron.ru)

**Адрес:** 198099, Санкт-Петербург,  
Промышленная ул, дом № 19, литера Н,  
помещение 100-Н Офис 331