

MINI MCR-RTD-UI-NC

Temperature transducers for resistance thermometers and remote resistance-type sensors



Data sheet
105446_en_00

© PHOENIX CONTACT 2013-01-14

1 Description

Configurable 3-way isolated temperature transducer. The device is suitable for the connection of resistance thermometers and remote resistance-type sensors in 2, 3 and 4-wire connection technology.

The measured values are converted into a linear current or voltage signal.

The device can either be configured via DIP switches or, with extended functionality, via the S port using the software (FDT/DTM).

The device supports fault monitoring.

Features

- Configurable 3-way temperature transducer
- Configurable via DIP switches for Pt 100 and Pt 1000 (IEC 751)
- Extended functionality configurable with free software
- Approval for Ex-zone 2 (nA)
- Screw or spring-cage connection can be provided

**WARNING: Correct usage in potentially explosive areas**

The module is a category 3 item of electrical equipment. It is absolutely vital to follow the instructions provided here during installation and observe the information in the "Safety regulations and installation notes".



Make sure you always use the latest documentation.

It can be downloaded from the product at www.phoenixcontact.net/products.



This data sheet is valid for all products listed on the following page:

2	Table of contents	
1	Description	1
2	Table of contents	2
3	Ordering data	3
4	Technical data	4
5	Safety regulations and installation notes.....	6
	5.1 Installation notes	6
	5.2 Installation in the Ex area (zone 2).....	6
6	Installation	7
	6.1 Connection notes	7
	6.2 Structure	7
	6.3 Block diagram.....	7
	6.4 Power supply.....	8
	6.5 Assembly.....	8
	6.6 Connecting the wires	9
7	Fault monitoring FM.....	10
8	Configuration	11
	8.1 Configuration via DIP switches	11
	8.2 Connectable sensors	11
	8.3 Configuration via software (FDT/DTM)	14
9	Diagnostic indicator	14

3 Ordering data

Description	Type	Order No.	Pcs. / Pkt.
Configurable temperature transducer for the connection of 2, 3, and 4-conductor resistance thermometers and resistance-type sensors. Can be configured via DIP switches or, with extended functionality, using the software. Screw connection, standard configuration.	MINI MCR-RTD-UI-NC	2902849	1
Configurable temperature transducer for the connection of 2, 3, and 4-conductor resistance thermometers and resistance-type sensors. Can be configured via DIP switches or, with extended functionality, using the software. Spring-cage connection, standard configuration.	MINI MCR-RTD-UI-SP-NC	2902850	1
Accessories			
Programming adapter with USB interface, for programming with software.	IFS-USB-PROG-ADAPTER	2811271	1
The MINI MCR-SL-PTB-FM(-SP) power terminal block is used to supply the supply voltage to the T-connector. The FM power terminal block offers the additional function of monitoring in combination with the fault monitoring module. Screw connection.	MINI MCR-SL-PTB-FM	2902958	1
The MINI MCR-SL-PTB-FM(-SP) power terminal block is used to supply the supply voltage to the T-connector. The FM power terminal block offers the additional function of monitoring in combination with the fault monitoring module. Spring-cage connection.	MINI MCR-SL-PTB-FM-SP	2902959	1
The fault monitoring module is used to evaluate and report group errors from the fault monitoring system and to monitor the supply voltages. The error is reported via an N/O contact. Screw connection, standard configuration.	MINI MCR-SL-FM-RC-NC	2902961	1
The fault monitoring module is used to evaluate and report group errors from the fault monitoring system and to monitor the supply voltages. The error is reported via an N/O contact. Spring-cage connection, standard configuration.	MINI MCR-SL-FM-RC-SP-NC	2902962	1
DIN rail connector (TBUS), 5-pos., for bridging the supply voltage, can be snapped onto NS 35/... DIN rails according to EN 60715	ME 6,2 TBUS-2 1,5/5-ST-3,81 GN	2869728	10
DIN rail power supply unit, primary-switched mode, slim design, output: 24 V DC / 1.5 A	MINI-SYS-PS-100-240AC/24DC/1.5	2866983	1
Eight MINI analog signal converters with screw connection method can be connected to a control system using a system adapter and system cabling with a minimum of wiring and very low error risk.	MINI MCR-SL-V8-FLK 16-A	2811268	1
MINI analog multiplexer, generates one analog output from 8 analog input signals, for MINI analog module with screw connection.	MINI MCR-SL-MUX-V8-FLK 16	2811815	1
Fold up transparent cover for MINI MCR modules with additional labeling option using insert strips and flat Zack marker strip 6.2 mm	MINI MCR DKL	2308111	10
Label for extended marking of MINI MCR modules in connection with the MINI MCR-DKL	MINI MCR-DKL-LABEL	2810272	10

4 Technical data

Input

Configurable/programmable	Yes
Sensor type	Pt, Ni, Cu sensors
Sensor input current	Approx. 200 μ A
Max. permissible overall conductor resistance	$\leq 25 \Omega$ (Per cable)
Linear resistance measuring range	0 Ω ... 4000 Ω (Minimum measuring span: 10% of the selected measuring range)
Temperature measuring range	-200 $^{\circ}$ C ... 850 $^{\circ}$ C (Range depending on the sensor type)
Measuring range span	min. 50 K
Connection method	2, 3, 4-wire

Output

Voltage output signal	0 V ... 10 V 10 V ... 0 V 0 V ... 5 V 1 V ... 5 V
Max. voltage output signal	Approx. 12.3 V
Current output signal	0 mA ... 20 mA 4 mA ... 20 mA 20 mA ... 0 mA 20 mA ... 4 mA
Max. current output signal	24.6 mA
Configurable/programmable	Yes
Load/output load voltage output	10 k Ω
Ripple	< 20 mV _{pp}
Load/output load current output	500 Ω (at 20 mA)

Supply

Supply voltage range	9.6 V DC ... 30 V DC (The T connector (ME 6,2 TBUS-2 1,5/5-ST-3,81 GN, Order No. 2869728) can be used to bridge the supply voltage. It can be snapped onto a 35 mm DIN rail according to EN 60715))
Typical current consumption	< 27 mA (at 24 V DC)
Power consumption	≤ 700 mW (at I _{OUT} = 20 mA, 9.6 V DC, load 500 Ω)

Diagnostic and status indicators

Status display	LED red
----------------	---------

General data

Transmission error resistance thermometer	0.1% * 350 K / set measuring range; 0.1% > 350 K (Pt/Ni) 0.3% * 200 K / set measuring range; 0.3% > 200 K (Cu)
Transmission error resistance-type sensor	2 Ω
Maximum temperature coefficient	0.01 %/K
Step response (0–99%)	Typ. 200 ms (2-wire) Typ. 500 ms (3-wire) Typ. 500 ms (4-wire)
Electrical isolation	Basic insulation according to EN 61010
Surge voltage category	II
Mounting position	Any
Degree of protection	IP20
Pollution degree	2
Rated insulation voltage	50 V AC/DC

General data [...]

Test voltage, input/output/supply	1.5 kV (50 Hz, 1 min.)
Dimensions W / H / D	6.2 mm / 93.1 mm / 102.5 mm
Type of housing	PBT green

Connection data

Screw connection

Spring-cage conn.

Conductor cross section, solid	0.2 mm ² ... 2.5 mm ²	0.2 mm ² ... 2.5 mm ²
Conductor cross section, stranded	0.2 mm ² ... 2.5 mm ²	0.2 mm ² ... 2.5 mm ²
Stripping length	12 mm	8 mm

Ambient conditions

Ambient temperature (operation)	-20 °C ... 65 °C
Ambient temperature (storage/transport)	-40 °C ... 85 °C
Permissible humidity (operation)	5 % ... 95 % (no condensation)

Conformance with EMC Directive 2004/108/EC

Noise immunity according to EN 61000-6-2
 When being exposed to interference, there may be minimal deviations.

Noise emission according to EN 61000-6-4

Conformance / approvals

Conformance	CE-compliant
ATEX	⊕ II 3 G Ex nA IIC T4 Gc X
UL, USA / Canada	UL 508 Recognized applied for
UL, USA / Canada	Class I, Div. 2, Groups A, B, C, D T5 applied for
Shipbuilding	GL applied for

5 Safety regulations and installation notes

5.1 Installation notes

- The category 3 device is suitable for installation in the zone 2 potentially explosive area. It fulfills the requirements of EN 60079-0:2009 and EN 60079-15:2010.
- Installation, operation, and maintenance may only be carried out by qualified electricians. Follow the installation instructions described. When installing and operating the device, the applicable regulations and safety directives (including national safety directives), as well as general technical regulations, must be observed. The technical data is provided in this package slip and on the certificates (conformity assessment, additional approvals where applicable).
- It is not permissible to open or modify the device. Do not repair the device yourself but replace it with an equivalent device. Repairs may only be carried out by the manufacturer. The manufacturer is not liable for damage resulting from violation.
- The IP20 degree of protection (IEC 60529/EN 60529) of the device is intended for use in a clean and dry environment. Do not subject the device to any load that exceeds the described limits.
- The device is not designed for use in atmospheres with a danger of dust explosions.

5.2 Installation in the Ex area (zone 2)

- Observe the specified conditions for use in potentially explosive areas.
- The device must be installed in a housing (control or distributor box) which meets the requirements of EN 60079-15 and provides at least IP54 (EN 60529) degree of protection.
- During installation and when connecting the supply and signal circuits, observe the requirements of EN 60079-14. Devices may only be connected to circuits in zone 2 if they are suitable for operation in Ex zone 2 and for the prevailing conditions at the place of use.
- In potentially explosive areas, terminals may only be snapped onto or off the DIN rail connector and wires may only be connected or disconnected when the power is switched off.
- The device must be stopped and immediately removed from the Ex area if it is damaged, has been subjected to an impermissible load, has been stored incorrectly, or if it malfunctions.
- You can download the latest documents for these devices from www.phoenixcontact.net/products.

6 Installation

6.1 Connection notes



NOTE: Electrostatic discharge!

The device contains components that can be damaged or destroyed by electrostatic discharge. When handling the device, observe the necessary safety precautions against electrostatic discharge (ESD) according to EN 61340-5-1 and EN 61340-5-2.

6.2 Structure

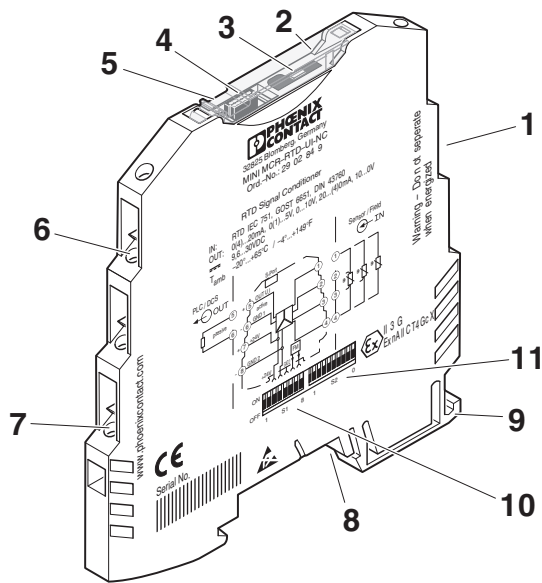

Figure 1 Structure

1. Input: resistance thermometer and remote resistance-type sensor
2. Cover
3. Diagnostics LED
4. S-PORT
5. Groove for ZBF 6 zack marker strip
6. Output: Standard signals
7. Supply voltage
8. Connection for DIN rail connector
9. Universal snap-on foot for EN DIN rails
10. DIP switch S1
11. DIP switch S2

6.3 Block diagram

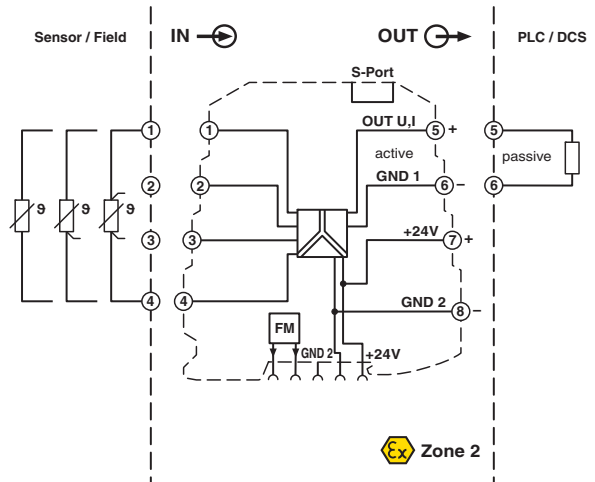

Figure 2 Block diagram

6.4 Power supply



NOTE: Never connect the supply voltage directly to the DIN rail connector. It is not permitted to draw power from the DIN rail connector or from individual modules.

Supply via the MINI Analog Module

Where the total current consumption of the aligned modules does not exceed 400 mA, the power can be supplied directly at the connection terminal blocks of the module.

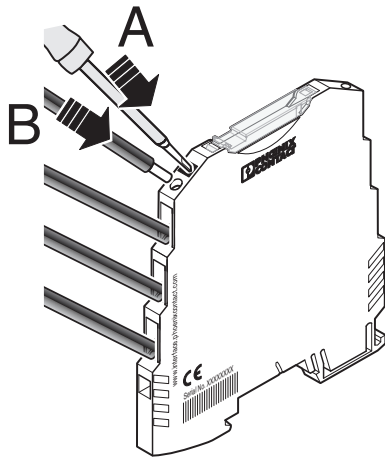

Figure 3 Spring-cage connection

A 400 mA fuse should be connected upstream.

Supply via a Power Terminal Block

The MINI MCR-SL-PTB-FM power terminal block (Order No. 2902958) or the MINI MCR-SL-PTB-FM-SP power terminal block (Order No. 2902959), which are the same shape, are used to feed the supply voltage to the DIN rail connector.

We recommend connecting a 2.5 A slow-blow fuse (e.g., SIBA 179 120.2,5 20x5).

Supply via a system power supply unit

The system power supply unit with 1.5 A output current connects the DIN rail connector to the supply voltage and can therefore be used to supply several modules from the mains.

- MINI-SYS-PS-100-240AC/24DC/1.5 (Order No. 2866983)
- Potentially explosive areas:
MINI-PS-100-240AC/24DC/1.5/EX (Order No. 2866653)

6.5 Assembly

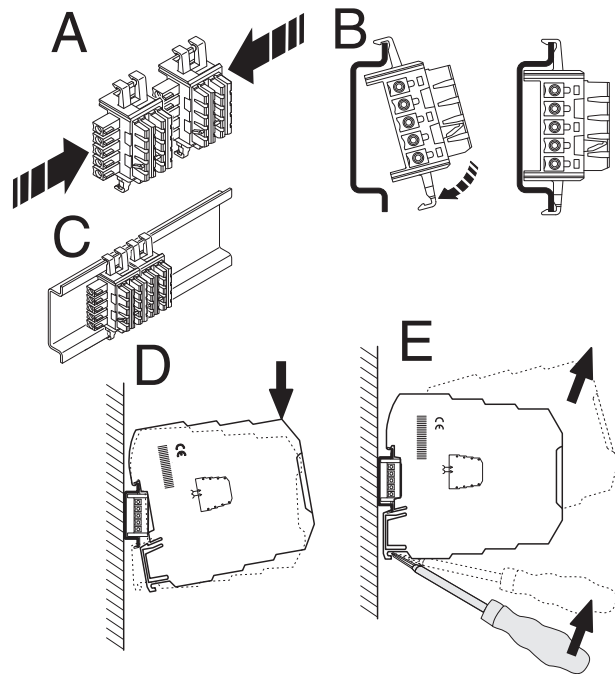

Figure 4 Mounting and removing

- Mount the module on a 35 mm DIN rail according to EN 60715.
- When using the DIN rail connector, first place it into the DIN rail (see A – C). It is used to bridge the power supply. It is also absolutely vital that you snap the module and the DIN rail connector into position in the correct direction: the snap-on foot should be at the bottom and the connector on the left.

6.6 Connecting the wires

The module is available in two connection versions:

- Screw terminal blocks (for MINI MCR-RTD-UI-NC)
- "Spring-cage terminal blocks (for MINI MCR-RTD-UI-SP-NC)

Screw connection:

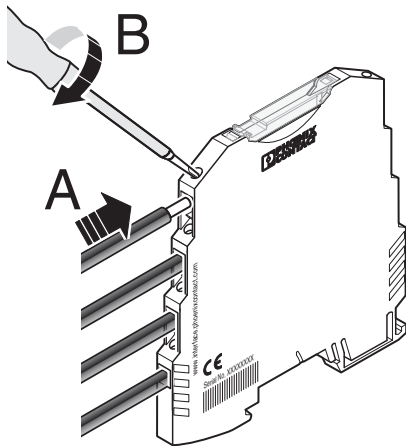

Figure 5 Screw connection

- Insert the wire into the corresponding connection terminal block.
- Use a screwdriver to tighten the screw in the opening above the connection terminal block.

Spring-cage connection:

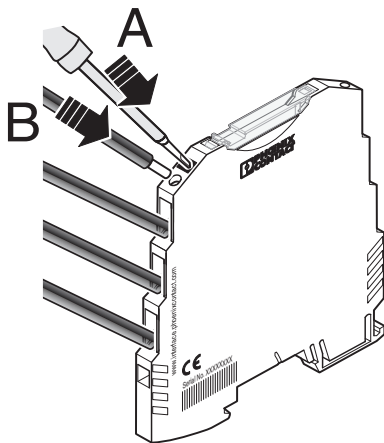

Figure 6 Spring-cage connection

- Insert a screwdriver into the opening above the connection terminal block.
- Insert the wire into the corresponding connection terminal block.

7 Fault monitoring FM

Detected errors on the signal input or in the device are reported via the DIN rail connector to the MINI MCR-SL-FM-RC-NC (Order No. 2902961) or MINI MCR-SL-FM-RC-SP-NC (Order No. 2902962), which are the same shape. The module reports the error centrally via an N/C contact.

In one group, a fault monitoring module is only required once. Individual evaluation of the up to 80 Phoenix Contact isolation amplifiers can be omitted.

The fault monitoring module can also be used to monitor the supply voltage.

- For the behavior of the fault monitoring contact for the different DIP switch configurations, please refer to the table.

Error response		Fault monitoring: N/C contact			
		Measuring range overrange	Measuring range underrange	Cable break	Short-circuit
A		activated	deactivated	activated	deactivated
B		activated	activated	activated	activated
C		deactivated	deactivated	activated	activated
D		deactivated	deactivated	deactivated	deactivated
NE43	Upscale	activated	activated	activated	activated
	Downscale				
	0 mA				
	Upscale/downscale				
Module error		Activated (error is always reported)			
Invalid DIP switch configuration		Activated (error is always reported)			

8 Configuration

The modules have the standard configuration:

- Sensor Pt 100 IEC 751
- 3-wire
- -50...150°C
- Output 4...20 mA
- Error evaluation according to NE43 (downscale)
- Fault monitoring contact reacts to all errors



The module can also be configured with the supply voltage not connected.

8.1 Configuration via DIP switches

At delivery, all DIP switches are in the "OFF" position.

Configure the DIP switches according to the planned application using the configuration tables.

DIP switch S1 is used to specify the configuration method, connection method, output signal range, and measuring range start value.

DIP switch S2 is used to specify the measuring range final value, sensor type (Pt 100/Pt 1000, IEC 751), and the error contact behavior.

8.2 Connectable sensors

Sensor type	Standard	Measuring range	Smallest measuring range span
Pt 100	IEC 751 = GOST 6651-2009 ($\alpha = 0.00385$)	-200°C ... +850°C	50 K
Pt 200	IEC 751 = GOST 6651-2009 ($\alpha = 0.00385$)	-200°C ... +850°C	50 K
Pt 500	IEC 751 = GOST 6651-2009 ($\alpha = 0.00385$)	-200°C ... +850°C	50 K
Pt 1000	IEC 751 = GOST 6651-2009 ($\alpha = 0.00385$)	-200°C ... +850°C	50 K
Pt 100	GOST 6651-2009 ($\alpha = 0.00391$)	-200°C ... +850°C	50 K
Pt 1000	GOST 6651-2009 ($\alpha = 0.00391$)	-200°C ... +850°C	50 K
Pt 100	JIS C1604-1997	-200°C ... +850°C	50 K
Pt 1000	JIS C1604-1997	-200°C ... +850°C	50 K
Ni 100	DIN 43760	-60°C ... +250°C	50 K
Ni 1000	DIN 43760	-60°C ... +250°C	50 K
Cu 50	GOST 6651-2009 ($\alpha = 1.428$)	-180°C ... +200°C	50 K
Cu 100	GOST 6651-2009 ($\alpha = 1.428$)	-180°C ... +200°C	50 K
Cu 53	GOST 6651-2009 ($\alpha = 1.426$)	-50°C ... +180°C	50 K
Customer-specific characteristic curves			

Configuration tables

		• ≙ ON DIP S1							
		1	2	3	4	5	6	7	8
Connection technology	Configuration via software								
	2-wire	•							
	3-wire		•						
	4-wire	•	•						
Analog output signal	0...20 mA								
	20...0 mA			•					
	4...20 mA				•				
	20...4 mA			•	•				
	0...10 V							•	
	10...0 V				•			•	
	0...5 V					•		•	
1...5 V				•	•		•		
Start temperature	0°C ≙ 32°F								
	-10°C ≙ 14°F							•	
	-20°C ≙ -4°F								•
	-30°C ≙ -22°F							•	•
	-40°C ≙ -40°F								•
	-50°C ≙ -58°F							•	•
	-100°C ≙ -148°F								•
	-150°C ≙ -238°F								•

Measuring range final value	DIP S2						• ≙ ON DIP S2										
	1	2	3	4	5	6	1	2	3	4	5	6	7	8	9	0	
0°C ≙ 32°F																	•
5°C ≙ 41°F	•																•
10°C ≙ 50°F		•															•
15°C ≙ 59°F	•	•															•
20°C ≙ 68°F			•														•
25°C ≙ 77°F	•	•	•														•
30°C ≙ 86°F		•	•														•
35°C ≙ 95°F	•	•	•														•
40°C ≙ 104°F				•													•
45°C ≙ 113°F	•			•													•
50°C ≙ 122°F		•		•													•
55°C ≙ 131°F	•	•		•													•
60°C ≙ 140°F			•	•													•
65°C ≙ 149°F	•		•	•													•
70°C ≙ 158°F		•	•	•													•
75°C ≙ 167°F	•	•	•	•													•
80°C ≙ 176°F					•												•
85°C ≙ 185°F	•				•												•
90°C ≙ 194°F		•			•												•
95°C ≙ 203°F	•	•			•												•
100°C ≙ 212°F			•		•												•
105°C ≙ 221°F	•		•		•												•
110°C ≙ 230°F		•			•												•
115°C ≙ 239°F	•	•			•												•
120°C ≙ 248°F				•													•
125°C ≙ 257°F	•			•	•												•
130°C ≙ 266°F		•		•	•												•
135°C ≙ 275°F	•	•		•	•												•
140°C ≙ 284°F			•		•												•
145°C ≙ 293°F	•		•	•	•												•
150°C ≙ 302°F		•	•	•	•												•
155°C ≙ 311°F	•	•	•	•	•												•
160°C ≙ 320°F																	•
165°C ≙ 329°F	•																•
170°C ≙ 338°F		•															•
175°C ≙ 347°F	•	•															•
180°C ≙ 356°F			•														•
185°C ≙ 365°F	•	•	•														•
190°C ≙ 374°F		•	•														•
195°C ≙ 383°F	•	•	•														•
200°C ≙ 392°F				•													•
210°C ≙ 410°F	•			•													•
220°C ≙ 428°F		•		•													•
230°C ≙ 446°F	•	•		•													•
240°C ≙ 464°F		•	•														•
250°C ≙ 482°F	•	•	•														•
260°C ≙ 500°F		•	•	•													•
270°C ≙ 518°F	•	•	•	•													•
280°C ≙ 536°F						•											•
290°C ≙ 554°F	•					•											•
300°C ≙ 572°F		•				•											•
325°C ≙ 617°F	•	•				•											•
350°C ≙ 662°F			•			•											•
375°C ≙ 707°F	•		•			•											•
400°C ≙ 752°F		•	•			•											•
425°C ≙ 797°F	•	•	•			•											•
450°C ≙ 842°F				•		•											•
475°C ≙ 887°F	•			•		•											•
500°C ≙ 932°F		•		•		•											•
550°C ≙ 1022°F	•	•		•		•											•
600°C ≙ 1112°F			•			•											•
650°C ≙ 1202°F	•	•	•			•											•
700°C ≙ 1292°F		•	•	•		•											•
850°C ≙ 1562°F	•	•	•	•		•											•

Fault evaluation	Analog OUT								• ≙ ON			
	0...20 mA	20...0 mA	4...20 mA	20...4 mA	0...10 V	10...0 V	0...5 V	1...5 V	DIP S2			
									7	8	9	0
A Cable break	21 mA	21 mA	21 mA	21 mA	10.5 V	10.5 V	5.25 V	5.25 V				
Overrange	20.5 mA	20.5 mA	20.5 mA	20.5 mA	10.25 V	10.25 V	5.125 V	5.125 V				
Underrange	0 mA	0 mA	4 mA	4 mA	0 V	0 V	0 V	1 V				
Short circuit	0 mA	0 mA	4 mA	4 mA	0 V	0 V	0 V	1 V				
B Cable break	21 mA	21 mA	21 mA	21 mA	10.5 V	10.5 V	5.25 V	5.25 V				
Overrange	20.5 mA	20.5 mA	20.5 mA	20.5 mA	10.25 V	10.25 V	5.125 V	5.125 V	•			
Underrange	0 mA	0 mA	3.5 mA	3.5 mA	0 V	0 V	0 V	0.875 V				
Short circuit	0 mA	0 mA	3 mA	3 mA	0 V	0 V	0 V	0.75 V				
C Cable break	21 mA	21 mA	21 mA	21 mA	10.5 V	10.5 V	5.25 V	5.25 V				
Overrange	20 mA	20 mA	20 mA	20 mA	10 V	10 V	5 V	5 V		•		
Underrange	0 mA	0 mA	4 mA	4 mA	0 V	0 V	0 V	1 V				
Short circuit	21 mA	21 mA	21 mA	21 mA	10.5 V	10.5 V	5.25 V	5.25 V				
D Cable break	0 mA	0 mA	4 mA	4 mA	0 V	0 V	0 V	1 V				
Overrange	20 mA	20 mA	20 mA	20 mA	10 V	10 V	5 V	5 V		•	•	
Underrange	0 mA	0 mA	4 mA	4 mA	0 V	0 V	0 V	1 V				
Short circuit	0 mA	0 mA	4 mA	4 mA	0 V	0 V	0 V	1 V				
NE43	(Only OUT = 4...20 mA or 20...4 mA)											
Upscale	Cable break, overrange, underrange, short circuit = 21.5 mA											•
Downscale	Cable break, overrange, underrange, short circuit = 3.5 mA									•		•
0 mA	Cable break, overrange, underrange, short circuit = 0 mA										•	•
Up/downscale	Cable break, short circuit = 3.5 mA											
	Overrange, underrange = 21.5 mA									•	•	•
Sensor type	Pt 100 (IEC 751)											
	Pt 1000 (IEC 751)											•

8.3 Configuration via software (FDT/DTM)



Use the IFS-USB-PROG-ADAPTER (Order No.: 2811271) for connecting the device to the PC.

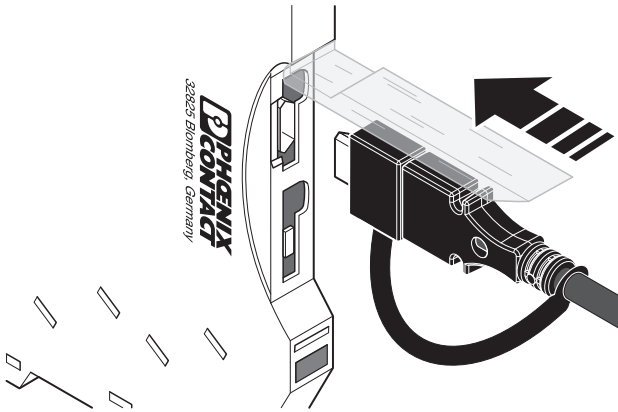

Figure 7 Connection for programming adapter

Software configuration provides advantages such as 13 different sensor types, customer-specific characteristic curves, free adjustment of signal output, temperature ranges, and error indication.

The software consists of the FDT framework application and a driver (DTM) for every device. The software is available free of charge on the Internet at www.phoenixcontact.com.

- Enter the order number of your measuring transducer in the search field. The installation packages can be found under Downloads.
- If you are already using an FDT framework application, only download the DTMs.
- In any other case, download the IFS-CONF software package. It contains both the framework application and the pre-installed DTMs.

ANALOG-CONF standard software

- If you do not require an FDT/DTM-based software solution, you can use the ANALOG-CONF standard software. This software also allows for performing all the settings on the device. The software is available free of charge on the Internet at www.phoenixcontact.com.



The USB driver for the programming adapter is part of the IFS-CONF, ANALOG-CONF, and of the DTM installation package.

9 Diagnostic indicator

The red LED indicates the following error states:

- LED flashes at 2.8 Hz: sensor error or invalid DIP switch configuration
- LED flashes at 1.4 Hz: simulation mode
- LED is permanently on: internal device error



Стандарт Электрон Связь

Мы молодая и активно развивающаяся компания в области поставок электронных компонентов. Мы поставляем электронные компоненты отечественного и импортного производства напрямую от производителей и с крупнейших складов мира.

Благодаря сотрудничеству с мировыми поставщиками мы осуществляем комплексные и плановые поставки широчайшего спектра электронных компонентов.

Собственная эффективная логистика и склад в обеспечивает надежную поставку продукции в точно указанные сроки по всей России.

Мы осуществляем техническую поддержку нашим клиентам и предпродажную проверку качества продукции. На все поставляемые продукты мы предоставляем гарантию .

Осуществляем поставки продукции под контролем ВП МО РФ на предприятия военно-промышленного комплекса России , а также работаем в рамках 275 ФЗ с открытием отдельных счетов в уполномоченном банке. Система менеджмента качества компании соответствует требованиям ГОСТ ISO 9001.

Минимальные сроки поставки, гибкие цены, неограниченный ассортимент и индивидуальный подход к клиентам являются основой для выстраивания долгосрочного и эффективного сотрудничества с предприятиями радиоэлектронной промышленности, предприятиями ВПК и научно-исследовательскими институтами России.

С нами вы становитесь еще успешнее!

Наши контакты:

Телефон: +7 812 627 14 35

Электронная почта: sales@st-electron.ru

Адрес: 198099, Санкт-Петербург,
Промышленная ул, дом № 19, литера Н,
помещение 100-Н Офис 331