



Eval Kit Manual

AS7265x Multispectral Chipset Evaluation Kit User Guide

Content Guide

1	Introduction.....	3
1.1	Kit Content.....	3
2	Getting Started	3
3	Hardware Description	4
3.1	Hardware Architecture	4
3.2	Power Supply	5
3.3	Interface to Controller	5
3.4	LEDs.....	6
4	Software Description.....	7
5	AS7265x Multispectral Chipset Schematics.....	8
6	Ordering & Contact Information	9
7	Copyrights & Disclaimer	10
8	Revision Information	11

1 Introduction

AS7265x Multispectral Chipset Evaluation Kit provides a platform to evaluate ams AS7265x Multispectral Chipset products with the Spectral Sensor Dashboard software running on a Windows personal computer. This user guide describes the features and functions of AS7265x Multispectral Chipset evaluation kit.

Note, the described Kit with the hardware release 1V1 is based on the generation 1 of the Multispectral Chipset. Therefore, please check in case of any firmware update if the firmware release is compatible to this hardware release For more details see the application note “AS7265x Design considerations”.

1.1 Kit Content

The following items are delivered with this Evaluation Kit.

Figure 1. Kit Content

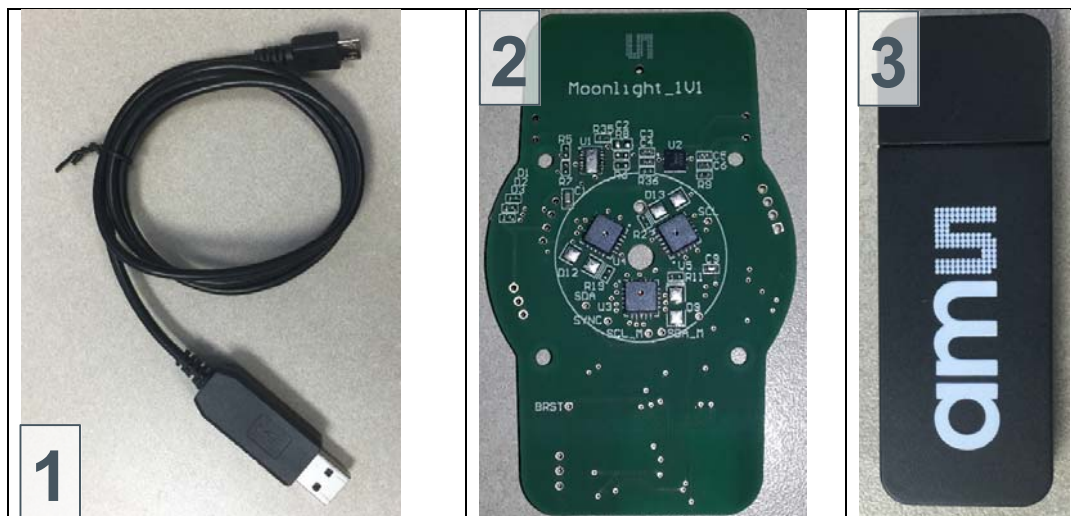

Pos.	Item	Comment
1	USB Cable	USB – UART Cable with MicroUSB Connector
2	AS7265x Multispectral Chipset Board	Evaluation Board
3	USB Data Stick	Documents and Software

2 Getting Started

The demo kit requires one time installation of FTDI Virtual COM Port Driver for the USB cable as well as ActiveState ActiveTcl Community Edition for the dashboard software if both are not already installed on the computer. Both installation files can be found in the USB Data Stick. If there is an issue about the installation, please refer to www.ftdichip.com and www.activestate.com for more information.

The Dashboard software does not require an installation. Please copy the following files to any folder you would like to work with and double click the “.tbc” file to start the GUI.

Figure 2. Dashboard Software Files

#	File	Comment
1	ams_Spectral_Sensor_Dashboard_x.x.xx.tbc	Tcl file with revision x.x.xx
2	ams_logo_xparent_h30.gif	ams logo

3 Hardware Description

The AS7265x Multispectral Chipset board by default consists of the UART interface, the LDO for 3.3V supply, AS72651/AS72652/AS72653 devices with associated flash memory, and the programming header for the flash memory.

If you would like to evaluate AS7265x Multispectral Chipset products with an I²C interface, the board also has the option for that. Please refer to the next section.

3.1 Hardware Architecture

Figure 3. Board Block Diagram

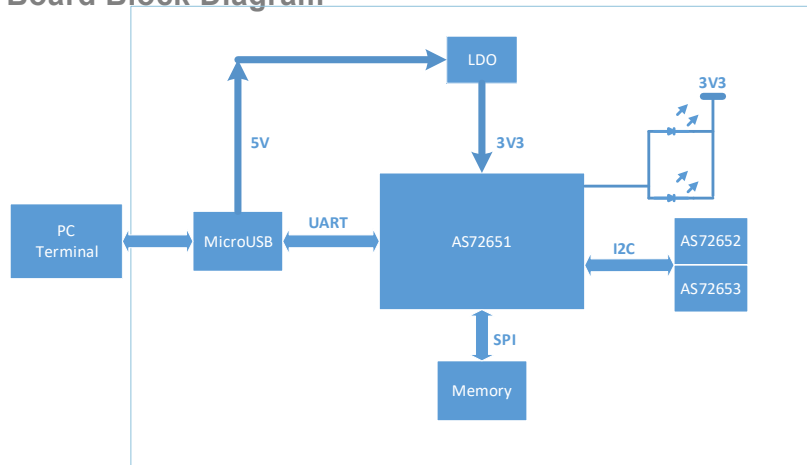
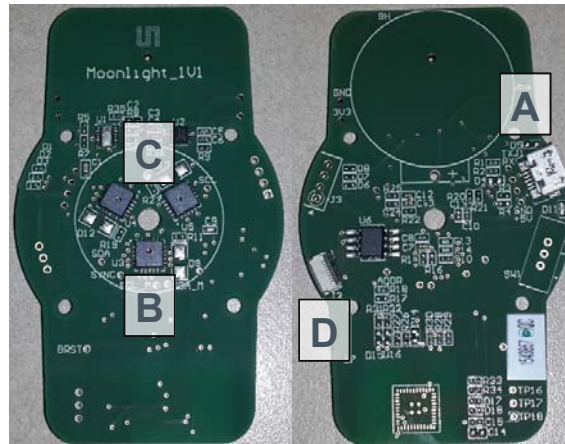

Figure 4. Connectors and LEDs



Pos.	Designator	Comment
A	J1	MicroUSB Connector; Connect to a personal computer;
B	AS72651, D9	AS72651 with Place Holders for the LED;
C	AS72652/3, D12/13	AS72652/3 with Place Holders for the LEDs;
D	J2	Flash Memory Programming Header;

3.2 Power Supply

The AS7265x Multispectral Chipset board will be powered up from the MicroUSB cable that connects to personal computer. The onboard LDO converts 5V USB power to 3.3V for the chipsets.

3.3 Interface to Controller

AS7265x Multispectral Chipset board by default has UART interface to a controller. A user could get the sensors data with the Dashboard software. J1 is the MicroUSB connector that connects the cable to a computer for UART interface. The cable has an internal USB-UART converter.

With a minor modification, I²C interface can be supported. The test points in next Figure could be used for I²C connection. The test point, TX, should be connected to SDA and the test point, RX, should be connected to SCL. Also R3/R4 are for I²C pull up resistors.

R17 and R18 would pull I²C_ENB pin of AS72651 up or down for selecting UART or I2C interfaces. Install R17 for I²C interface and install R18 for UART interface.

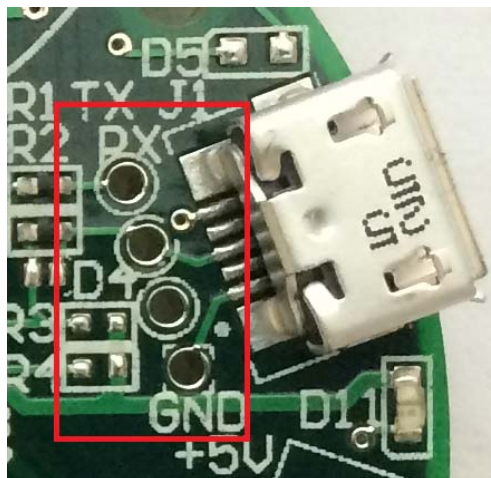

3.4 LEDs

Some of customer applications require external LEDs as the light source. The AS7265x Multispectral Chipset demo board has some place holders for this purpose. Each LED is series with a current limit resistor. By default, the LEDs and the resistors are not populated.

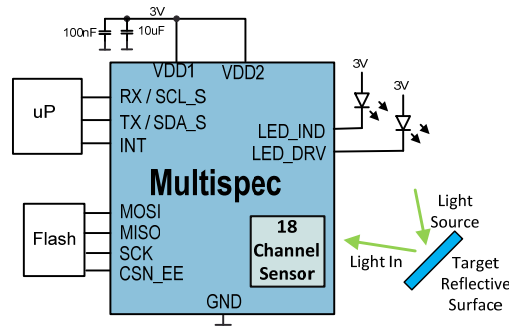

A generic application of AS7265x is to shine light rays to a target and AS7265x produces outputs based on the reflected light rays as shown in the above figure. So LED selection is determined by the spectral responsivity of reflected light and characteristics of the target. For example, if the target is expected to absorb 680nm light and the application needs to distinguish the target from others, a broadband white LED might be used as the light source with AS72651 and the 680nm channel should be checked. Various applications may require different light sources. The place holders for LEDs are D9, D12, and D13. D9 is connected to AS72651 and ATLED0 = 100/0 turns D9 ON/OFF. D12 is controlled by AS72652 and ATLED2 = 100/0 turns it ON/OFF. D13 is controlled by AS72653 and ATLEDE = 100/0 turns it ON/OFF. The AS7265x device supports various LED currents, 12.5mA, 25mA, 50mA, or 100mA. ATLEDC = 0/16/32/48 (decimal) sets the current through D9 to 12.5mA/25mA/50mA/100mA. Similarly ATLEDD sets the current of D12 and ATLEDE sets the current of D13.

The LED currents can be also controlled and configured with the virtual I²C registers, 0x07 (the register address 0x87 for write) for D9, 0x2E (the register address 0xAE for write) for D12, and 0x2F (the register address 0xAF for write) for D13.

Addr: 0x07/0x87		LED Control		
Bit	Bit Name	Default	Access	Bit Description
7:6	RSVD	0	R	Reserved
5:4	ICL_DRV	00	R/W	LED_DRV current limit 'b00=12.5mA; 'b01=25mA; 'b10=50mA; 'b11=100mA;
3	LED_DRV	0	R/W	Enable LED_DRV 1: Enabled; 0: Disabled
2:1	ICL_IND	00	R/W	LED_IND current limit 'b00=1mA; 'b01=2mA; 'b10=4mA; 'b11=8mA;

Addr: 0x07/0x87		LED Control		
0	LED_IND	0	R/W	Enable LED_IND 1: Enabled; 0: Disabled

Since the power to the LEDs is 5V, the actual current through LEDs might be smaller if the forward of LED is high. If this is the case, please connect the LED with an external power and pick the serial resistor value based on the forward voltage of the LED and the desired LED current. Please refer to the LED I-V curve specification. If the forward of LED is low, the current limit resistor can be installed with 0Ω.

4 Software Description

It would be easier to evaluate AS7265x Multispectral Chipset solution with AT commands through UART interface. The Spectral Sensor Dashboard software running on a Windows computer would be ideal. The USB Data Stick has the application note for the Spectral Sensor Dashboard software.

For I²C interface, the platform provides the option to connect to I²C interface and a customer would need to develop a program to read the sensors data.

6 Ordering & Contact Information

Ordering Code	Description
AS7265x Demo Kit	AS7265x Multispectral Chipset i-SPI-B Evaluation Kit

Buy our products or get free samples online at:

www.ams.com/ICdirect

Technical Support is available at:

www.ams.com/Technical-Support

Provide feedback about this document at:

www.ams.com/Document-Feedback

For further information and requests, e-mail us at:

ams_sales@ams.com

For sales offices, distributors and representatives, please visit:

www.ams.com/contact

Headquarters

ams AG

Tobelbaderstrasse 30

8141 Unterpremstaetten

Austria, Europe

Tel: +43 (0) 3136 500 0

Website: www.ams.com

7 Copyrights & Disclaimer

Copyright ams AG, Tobelbader Strasse 30, 8141 Unterpremstaetten, Austria-Europe. Trademarks Registered. All rights reserved. The material herein may not be reproduced, adapted, merged, translated, stored, or used without the prior written consent of the copyright owner.

Demo Kits, Evaluation Kits and Reference Designs are provided to recipient on an “as is” basis for demonstration and evaluation purposes only and are not considered to be finished end-products intended and fit for general consumer use, commercial applications and applications with special requirements such as but not limited to medical equipment or automotive applications. Demo Kits, Evaluation Kits and Reference Designs have not been tested for compliance with electromagnetic compatibility (EMC) standards and directives, unless otherwise specified. Demo Kits, Evaluation Kits and Reference Designs shall be used by qualified personnel only.

ams AG reserves the right to change functionality and price of Demo Kits, Evaluation Kits and Reference Designs at any time and without notice.

Any express or implied warranties, including, but not limited to the implied warranties of merchantability and fitness for a particular purpose are disclaimed. Any claims and demands and any direct, indirect, incidental, special, exemplary or consequential damages arising from the inadequacy of the provided Demo Kits, Evaluation Kits and Reference Designs or incurred losses of any kind (e.g. loss of use, data or profits or business interruption however caused) as a consequence of their use are excluded.

ams AG shall not be liable to recipient or any third party for any damages, including but not limited to personal injury, property damage, loss of profits, loss of use, interruption of business or indirect, special, incidental or consequential damages, of any kind, in connection with or arising out of the furnishing, performance or use of the technical data herein. No obligation or liability to recipient or any third party shall arise or flow out of ams AG rendering of technical or other services.

8 Revision Information

Changes from previous version to current revision 1-07 (2018-May-23)

Updated LED Section – ATLEDx functions in text

Multispectral Sensor Kit Generation 1 and limitations

Note: Page numbers for the previous version may differ from page numbers in the current revision.
Correction of typographical errors is not explicitly mentioned.



Стандарт Электрон Связь

Мы молодая и активно развивающаяся компания в области поставок электронных компонентов. Мы поставляем электронные компоненты отечественного и импортного производства напрямую от производителей и с крупнейших складов мира.

Благодаря сотрудничеству с мировыми поставщиками мы осуществляем комплексные и плановые поставки широчайшего спектра электронных компонентов.

Собственная эффективная логистика и склад в обеспечивает надежную поставку продукции в точно указанные сроки по всей России.

Мы осуществляем техническую поддержку нашим клиентам и предпродажную проверку качества продукции. На все поставляемые продукты мы предоставляем гарантию .

Осуществляем поставки продукции под контролем ВП МО РФ на предприятия военно-промышленного комплекса России , а также работаем в рамках 275 ФЗ с открытием отдельных счетов в уполномоченном банке. Система менеджмента качества компании соответствует требованиям ГОСТ ISO 9001.

Минимальные сроки поставки, гибкие цены, неограниченный ассортимент и индивидуальный подход к клиентам являются основой для выстраивания долгосрочного и эффективного сотрудничества с предприятиями радиоэлектронной промышленности, предприятиями ВПК и научно-исследовательскими институтами России.

С нами вы становитесь еще успешнее!

Наши контакты:

Телефон: +7 812 627 14 35

Электронная почта: sales@st-electron.ru

Адрес: 198099, Санкт-Петербург,
Промышленная ул, дом № 19, литера Н,
помещение 100-Н Офис 331