

MAX14890E

Incremental Encoder Interface for RS-422, HTL, and TTL with Digital Inputs

General Description

The MAX14890E incremental encoder receiver contains four differential receivers and two single-ended receivers.

The differential receivers can be operated in RS-422 or differential high-threshold logic (HTL) modes and are optionally configurable for single-ended TTL/HTL operation. The MAX14890E features a wide common mode input range of -20V to +20V in RS-422 mode.

The auxiliary IEC 61131-2 Type-1/Type-3 digital inputs are designed for operation with switches or proximity sensors and can be individually configured for TTL operation.

All receiver input signals are fault protected to voltage shorts in the ±40V range. Per channel fault detection provides warning of irregular conditions such as small differential signals, shorts, opens, overvoltages, and undervoltages.

The MAX14890E features a pin-selectable SPI or parallel-logic interface. SPI control provides detailed diagnostics and individual configurations for receivers.

The MAX14890E is available in a 32-pin TQFN-EP (5mm x 5mm) and operates over the -40°C to +125°C temperature range.

Ordering Information appears at end of data sheet.

Typical Operating Circuit

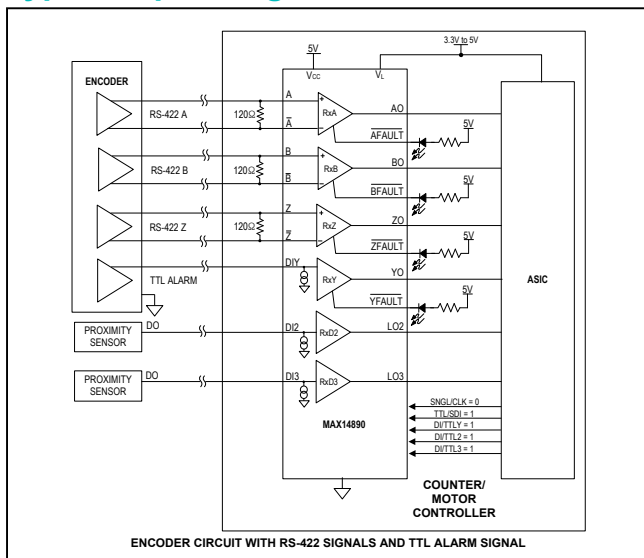

Benefits and Features

- High Flexibility Supports All Encoder Types
 - Selectable RS-422/HTL/TTL/DI Receivers
 - RS-422/TTL Switching Rates Up to 35Mbps
 - HTL Switching Rates Up to 400kHz
 - SPI or Pin-Controlled Operation
 - SPI Interface Allows Per-Receiver Configuration
 - 1.62V to 5.5V Logic Interface
- Integrated Fault Detection Reduces Down-Time
 - Open-Wire and Short-Circuit Detection
 - Overvoltage and Undervoltage Fault Detection
- Integrated Protection Ensures Robust Communication
 - ±40V Fault Protection Range
 - ±20V RS-422 Common Mode Range
 - DI Glitch Filters
 - ±25kV HBM ESD
 - ±7kV Air-Gap per IEC 61000-4-2 ESD
 - ±10kV Contact per IEC 61000-4-2 ESD
 - -40°C to +125°C Operating Temperature Range

Applications

- Encoder Interfaces
- Motor Controllers
- Pulse Counters
- Servo Control Commutation

Input Receiver Modes

| MODE | RxA | RxB | RxZ | RxY | RxDI2 | RxDI3 |
|--------|-----|-----|-----|-----|-------|-------|
| RS-422 | √ | √ | √ | √ | | |
| D-HTL | √ | √ | √ | | | |
| SE-HTL | √ | √ | √ | | | |
| TTL | √ | √ | √ | √ | √ | √ |
| DI | | | √ | √ | √ | √ |

Absolute Maximum Ratings

(All voltages referenced to GND)

| | |
|---|-----------------------------------|
| V _{CC} | -0.3V to +6V |
| V _L | -0.3V to (V _{CC} + 0.3V) |
| AO, BO, ZO, YO, LO, LO2, LO3 | -0.3V to (V _L + 0.3V) |
| <u>FAULT</u> , D2FAULT/IRQ..... | -0.3V to +6V |
| D3FAULT/ SDO (SPI is High)..... | -0.3V to (V _L + 0.3V) |
| D3FAULT/SDO (SPI is Low) | -0.3V to +6V |
| TTL/SDI, SNGL/SCLK, HITH/ <u>CS</u> , DI/TTLY, DI/TTL2, DI/TTL3, SPI | -0.3V to +6V |
| A, <u>A</u> , B, <u>B</u> , Z, <u>Z</u> , DIY, <u>Y</u> , DI2, DI3..... | -40V to +40V |

| | |
|--|-----------------|
| Short-Circuit Duration (<u>O</u> , <u>FAULT</u> , LO2, D2FAULT/IRQ, LO3, D3FAULT/SDO to GND) | Continuous |
| Continuous Power Dissipation (T _A = +70°C) Thin QFN (derate 19mW/°C above +70°C)..... | 1520mW |
| Operating Temperature Range..... | -40°C to +125°C |
| Junction Temperature..... | +150°C |
| Storage Temperature Range..... | -65°C to +150°C |
| Lead Temperature (Soldering, 10s)..... | +300°C |
| Soldering Temperature (Reflow)..... | +260°C |

Stresses beyond those listed under "Absolute Maximum Ratings" may cause permanent damage to the device. These are stress ratings only, and functional operation of the device at these or any other conditions beyond those indicated in the operational sections of the specifications is not implied. Exposure to absolute maximum rating conditions for extended periods may affect device reliability.

Package Thermal Characteristics (Note 1)

| | | | |
|---|--------|---|-------|
| Junction-to-Ambient Thermal Resistance (θ _{JA}) | 36°C/W | Junction-to-Case Thermal Resistance (θ _{JC})..... | 3°C/W |
|---|--------|---|-------|

Note 1: Package thermal resistances were obtained using the method described in JEDEC specification JESD51-7, using a four-layer board. For detailed information on package thermal considerations, refer to www.maximintegrated.com/thermal-tutorial.

Electrical Characteristics

(V_{CC} = 5V±10%, V_L = 1.62V to V_{CC}, T_A = -40°C to +125°C unless otherwise noted. Typical values are at V_{CC} = 5V, V_L = 3.3V, T_A = +25°C.) (Notes 2, 3)

| PARAMETER | SYMBOL | CONDITIONS | MIN | TYP | MAX | UNITS |
|---|-----------------------|---|------------------------|------|------|-------|
| POWER SUPPLY | | | | | | |
| Supply Voltage | V _{CC} | | 4.5 | | 5.5 | V |
| Supply Current | I _{CC} | Outputs not switching, no load | | 9 | 14 | mA |
| Logic Supply Voltage | V _L | | 1.62 | | 5.5 | V |
| RS-422 RECEIVERS (RxA, RxB, RxZ, RxY) | | | | | | |
| Differential Threshold Voltage | V _{TH} | -20V ≤ V _{CM} ≤ +20V | -200 | | +200 | mV |
| Differential Input Hysteresis | ΔV _{TH} | -20V ≤ V _{CM} ≤ +20V | | 230 | | mV |
| Single-Ended Input Current | I _{IN} | V _{CC} = 0V or 5V | V _{IN} = +10V | +100 | +160 | μA |
| | | | V _{IN} = -10V | -270 | -170 | |
| Low Differential Voltage Fault Threshold | V _{TH_DFP} | -20V ≤ V _{CM} ≤ +20V, positive | +270 | | +460 | mV |
| | V _{TH_DFN} | -20V ≤ V _{CM} ≤ +20V, negative | -460 | | -270 | |
| Single-Ended Input Fault Threshold | V _{TH_SEL P} | Positive | +15 | | +18 | V |
| | V _{TH_SEL N} | Negative | -18 | | -15 | |
| DIFFERENTIAL HTL RECEIVERS (RxA, RxB, RxZ) | | | | | | |
| Differential Threshold Voltage | V _{TH} | 0V ≤ V _{CM} ≤ +25V | -900 | | +900 | mV |
| Differential Input Hysteresis | ΔV _{TH} | 0V ≤ V _{CM} ≤ +25V | | 1 | | V |
| Single-Ended Input Current | I _{IN} | V _{TH} = +24V | | +280 | +460 | μA |
| | | V _{TH} = -10V | -270 | -170 | | |

Electrical Characteristics (continued)

($V_{CC} = 5V \pm 10\%$, $V_L = 1.62V$ to V_{CC} , $T_A = -40^\circ C$ to $+125^\circ C$ unless otherwise noted. Typical values are at $V_{CC} = 5V$, $V_L = 3.3V$, $T_A = +25^\circ C$.) (Notes 2, 3)

| PARAMETER | SYMBOL | CONDITIONS | MIN | TYP | MAX | UNITS |
|---|----------------------|---|------|------|------|---------|
| Low Differential Voltage Fault Threshold | V_{TH_DFP} | $0V \leq V_{CM} \leq +24V$, Positive | +1.2 | | +2.0 | V |
| | V_{TH_DFN} | $0V \leq V_{CM} \leq +24V$, Negative | -2.0 | | -1.2 | |
| Single-Ended Input Fault Threshold | V_{TH_SEN} | Negative | -18 | | -15 | V |
| SINGLE-ENDED HTL RECEIVERS (RxA, RxB, RxZ) | | | | | | |
| Input Logic High Voltage | V_{IH_SE} | HITH is low | 8 | | 40 | V |
| | | HITH is high | 13 | | 40 | |
| Input Logic Low Voltage | V_{IL_SE} | HITH is low | -40 | | 6 | V |
| | | HITH is high | -40 | | 11 | |
| Input Hysteresis | ΔV_{ITH_SE} | | | 270 | | mV |
| Input Current (A, B, Z) | $I_{_HTL}$ | $V_{CC} = 0V$ or normally powered, $V_{IN} = 24V$ | | | 460 | μA |
| Input Current (\bar{A} , \bar{B} , \bar{Z}) | $I_{_HTL}$ | $V_{CC} = 0V$ or normally powered, $V_{IN} = 24V$ | | | 460 | μA |
| Fault Threshold Voltage | V_{TH_HTLF} | | -18 | | -15 | V |
| TTL RECEIVERS (RxA, RxB, RxZ, RxY, RxD2, RxD3) | | | | | | |
| Input High Voltage | V_{IH_TTL} | TTL mode | 2.0 | | 40 | V |
| Input Low Voltage | V_{IL_TTL} | TTL mode | -40 | | 0.8 | V |
| Input Hysteresis | V_{HY_TTL} | TTL mode | | 0.53 | | V |
| Input Current (A, B, Z, DIY, DI2, DI3) | $I_{_TTL}$ | TTL mode, $V_{CC} = 0V$ or $5V$, $V_{IN} = 5V$ | | | 85 | μA |
| Input Current (\bar{A} , \bar{B} , \bar{Z} , \bar{Y}) | $I_{_TTL}$ | TTL mode, $V_{CC} = 0V$ or $5V$, $V_{IN} = 5V$ | | | 85 | |
| Fault Threshold Voltage | V_{TH_TTLF} | Negative | -18 | | -15 | V |
| | | Positive | +15 | | +18 | |
| DIGITAL INPUT RECEIVERS (DI2, DI3, RxY, RxZ) | | | | | | |
| Input High Voltage | V_{IH_DI} | DI mode, HITH is high or low | 8 | | 40 | V |
| Input Low Voltage | V_{IL_DI} | DI mode, HITH is high or low | -40 | | 5.5 | V |
| Input Hysteresis | V_{HY_DI} | DI mode, HITH is high or low | | 1.2 | | V |

Electrical Characteristics (continued)

(V_{CC} = 5V±10%, V_L = 1.62V to V_{CC}, T_A = -40°C to +125°C unless otherwise noted. Typical values are at V_{CC} = 5V, V_L = 3.3V, T_A = +25°C.) (Notes 2, 3)

| PARAMETER | SYMBOL | CONDITIONS | MIN | TYP | MAX | UNITS |
|---|---------------------|---|-----------------------|------|----------------------|-------|
| Current Sink | I _{DI} | DI mode, 0V ≤ V _{DI} ≤ 5V | 0 | | 2.6 | mA |
| | | DI mode, 8V ≤ V _{DI} ≤ 40V | 2 | 2.5 | 3.3 | |
| Fault Threshold Voltage | V _{TH_DIF} | DI mode | -18 | | -15 | V |
| LOGIC INTERFACE (AO, $\overline{\text{AFAULT}}$, BO, $\overline{\text{BFAULT}}$, ZO, $\overline{\text{ZFAULT}}$, YO, $\overline{\text{YFAULT}}$, LO2, $\overline{\text{D2FAULT/IRQ}}$, LO3, $\overline{\text{D3FAULT/SDO}}$, DI/TTL2, DI/TTL3, SPI, TTL/SDI, SNGL/CLK, HITH/$\overline{\text{CS}}$) | | | | | | |
| Input High Voltage | V _{IH} | DI/TTL2, DI/TTL3, SPI, TTL/SDI, SNGL/CLK, HITH/ $\overline{\text{CS}}$ | 2/3 x V _L | | | V |
| Input Low Voltage | V _{IL} | DI/TTL2, DI/TTL3, SPI, TTL/SDI, SNGL/CLK, HITH/ $\overline{\text{CS}}$ | | | 1/3 x V _L | V |
| Input Current | I _{IN} | DI/TTL2, DI/TTL3, SPI, TTL/SDI, SNGL/CLK, HITH/ $\overline{\text{CS}}$ | -1 | | +1 | µA |
| Output High Voltage | V _{OH} | AO, BO, ZO, YO, LO2, LO3, AO, BO, ZO, YO, LO2, LO3, $\overline{\text{D2FAULT/IRQ}}$, $\overline{\text{D3FAULT/SDO}}$, I _{OUT} = -3mA (Note 4) | V _L - 0.4V | | | V |
| Output Low Voltage | V _{OL} | AO, BO, ZO, YO, LO2, LO3, $\overline{\text{D3FAULT/SDO}}$, $\overline{\text{AFAULT}}$, $\overline{\text{BFAULT}}$, $\overline{\text{ZFAULT}}$, $\overline{\text{YFAULT}}$, $\overline{\text{D2FAULT/IRQ}}$, I _{OUT} = +3mA | | | 0.4 | V |
| PROTECTION | | | | | | |
| Thermal-Shutdown Threshold | T _{SHDN} | Temperature rising | | +160 | | °C |
| Thermal-Shutdown Hysteresis | T _{HYST} | | | 10 | | °C |
| Fault-Protected Input Voltage Range (A, $\overline{\text{A}}$, B, $\overline{\text{B}}$, Z, $\overline{\text{Z}}$, DIY, $\overline{\text{Y}}$, DI2, DI3) | V _{IN_F} | | -40 | | +40 | V |
| ESD Protection (A, $\overline{\text{A}}$, B, $\overline{\text{B}}$, Z, $\overline{\text{Z}}$, DIY, $\overline{\text{Y}}$, DI2, DI3) | | IEC 61000-4-2 Air-Gap Discharge to GND | ±7 | | | kV |
| | | IEC 61000-4-2 Contact Discharge to GND | ±10 | | | |
| | | Human body model | ±25 | | | |
| ESD Protection (all other pins) | | Human body model | ±2 | | | kV |

Switching Characteristics

($V_{CC} = 5V \pm 10\%$, $V_L = 1.62V$ to V_{CC} , $T_A = -40^\circ C$ to $+125^\circ C$ unless otherwise noted. Typical values are at $V_{CC} = 5V$, $V_L = 3.3V$, $T_A = +25^\circ C$.) (Notes 2, 3)

| PARAMETER | SYMBOL | CONDITIONS | | MIN | TYP | MAX | UNITS | |
|--|----------------------|--|--|--------------|-----|-----|-------|-----|
| RECEIVER (RxA, RxB, RxZ) (Note 4) | | | | | | | | |
| RS-422 Maximum Data Rate | DR_{MAX422} | RS-422 mode | | 35 | | | Mbps | |
| RS-422 Receiver Propagation Delay | t_{DPLH_422} | RS-422 mode, $C_L = 15pF$, $V_{ID} = \pm 3V$, Figures 1, 2 | | | | 25 | ns | |
| | t_{DPHL_422} | | | | | 25 | | |
| RS-422 Receiver Propagation Delay Skew $ t_{DPLH_422} - t_{DPHL_422} $ | $t_{HL-SKEW_422}$ | RS-422 mode, $C_L = 15pF$, $V_{ID} = \pm 3V$, Figures 1, 2 | | 0 | | 5 | ns | |
| RS-422 Receiver Channel-to-Channel Skew | $ t_{C-SKEW_422} $ | RS-422 mode, $C_L = 15pF$, $V_{ID} = \pm 3V$, Figures 1, 2 | | 0 | | 8 | ns | |
| Differential HTL (D-HTL) Maximum Differential Data Rate | DR_{DHTL} | D-HTL mode | | 1 | | | Mbps | |
| D-HTL Receiver Propagation Delay | t_{DPLH_DHTL} | D-HTL mode, $C_L = 15pF$, $V_{ID} = \pm 24V$, Figures 1, 2 | | | | 100 | ns | |
| | t_{DPHL_DHTL} | | | | | 100 | | |
| D-HTL Differential Receiver Propagation Delay Skew $ t_{DPLH_DHTL} - t_{DPHL_DHTL} $ | t_{HLSKEW_DHTL} | D-HTL mode, $C_L = 15pF$, $V_{ID} = \pm 24V$, Figures 1, 2 | | 0 | | 20 | ns | |
| D-HTL Differential Receiver Channel-to-Channel Skew | $ t_{CSKEW_DHTL} $ | D-HTL mode, $C_L = 15pF$, $V_{ID} = \pm 24V$, Figures 1, 2 | | 0 | | 8 | ns | |
| Single-Ended (SE-HTL) Maximum Switching Rate | SR_{SEHTL} | SE-HTL mode, HITH is high or low | | 400 | | | kHz | |
| SE-HTL Receiver Propagation Delay | t_{DPLH_SEHTL} | SE-HTL mode, HITH is high or low, $C_L = 15pF$, $0V \leq V_{IN} \leq +24V$, Figures 1, 2 | | | | 0 | ns | |
| | t_{DPHL_SEHTL} | | | | | 0 | | 100 |
| SE-HTL Receiver Propagation Delay Skew $ t_{DPLH_SEHTL} - t_{DPHL_SEHTL} $ | t_{HLSKEW_SEHTL} | SE-HTL mode, $C_L = 15pF$, $0V \leq V_{IN} \leq +24V$ | | HITH is low | | 0 | 28 | ns |
| | | | | HITH is high | | 0 | 20 | |
| SE-HTL Receiver Channel-to-Channel Skew | $ t_{CSKEW_SEHTL} $ | SE-HTL mode, HITH is high or low, $C_L = 15pF$, $0V \leq V_{IN} \leq +24V$, Figures 1, 2 | | 0 | | 11 | ns | |
| TTL Maximum Switching Rate | SR_{TTL} | TTL mode | | 400 | | | kHz | |
| TTL Receiver Propagation Delay | t_{DPLH_TTL} | TTL mode, $C_L = 15pF$, $0V \leq V_{IN} \leq +5V$, Figures 1, 2 | | | | 100 | ns | |
| | t_{DPHL_TTL} | | | | | 100 | | |
| TTL Receiver Propagation Delay Skew $(t_{DPLH_TTL} - t_{DPHL_TTL})$ | t_{HLSKEW_TTL} | TTL mode, $C_L = 15pF$, $0V \leq V_{IN} \leq +5V$, Figures 1, 2 | | 0 | | 52 | ns | |

Switching Characteristics (continued)

($V_{CC} = 5V \pm 10\%$, $V_L = 1.62V$ to V_{CC} , $T_A = -40^\circ C$ to $+125^\circ C$ unless otherwise noted. Typical values are at $V_{CC} = 5V$, $V_L = 3.3V$, $T_A = +25^\circ C$.) (Notes 2, 3)

| PARAMETER | SYMBOL | CONDITIONS | MIN | TYP | MAX | UNITS |
|--|---------------------|---|-----|-----|-----|-------|
| TTL Receiver Channel-to-Channel Skew | $ t_{CSKEW_TTL} $ | TTL mode, $C_L = 15pF$, $0V \leq V_{IN} \leq +5V$, Figures 1, 2 | 0 | | 11 | ns |
| Digital Input (DI) Maximum Switching Rate | SR_{DZ} | RxZ only, DI mode, SPI = high | 400 | | | kHz |
| DI Propagation Delay | t_{DPLH_DZ} | RxZ only, DI mode, SPI = high, $C_L = 15pF$, $0V \leq V_{IN} \leq +24V$, Figures 1, 2 | | | 300 | ns |
| | t_{DPHL_DZ} | | | | 300 | |
| DI Receiver Propagation Delay Skew $ t_{DPLH_DZ} - t_{DPHL_DZ} $ | t_{RSKEW_DZ} | RxZ only, DI mode, SPI = high, $C_L = 15pF$, $0V \leq V_{IN} \leq +24V$, Figures 1, 2 | 0 | | 28 | ns |
| DI Maximum Glitch Duration for Glitch Rejection | t_{GL} | RxZ only, DI mode, SPI = high | | | 80 | ns |
| DI Admitted Pulse Duration | t_{PASS} | RxZ only, DI mode, SPI = high | 300 | | | ns |
| RECEIVER (RxY) (Note 5) | | | | | | |
| RS-422 Maximum Data Rate | DR_{MAX422} | RS-422 mode | 35 | | | Mbps |
| RS-422 Receiver Propagation Delay | t_{DPLH_422} | RS-422 mode, $C_L = 15pF$, $V_{ID} = \pm 3V$, Figures 1, 2 | | | 25 | ns |
| | t_{DPHL_422} | | | | 25 | ns |
| RS-422 Receiver Propagation Delay Skew $ t_{DPLH_422} - t_{DPHL_422} $ | $t_{HL-SKEW_422}$ | RS-422 mode, $C_L = 15pF$, $V_{ID} = \pm 3V$, Figures 1, 2 | 0 | | 5 | ns |
| RS-422 Receiver Channel-to-Channel Skew | $ t_{C-SKEW_422} $ | RS-422 mode, $C_L = 15pF$, $V_{ID} = \pm 3V$, Figures 1, 2 | 0 | | 8 | ns |
| TTL Maximum Switching Rate | SR_{TTL} | TTL mode | 400 | | | kHz |
| TTL Receiver Propagation Delay | t_{DPLH_TTL} | TTL mode, $C_L = 15pF$, $0V \leq V_{IN} \leq +5V$, Figures 1, 2 | | | 100 | ns |
| | t_{DPHL_TTL} | | | | 100 | |
| TTL Receiver Propagation Delay Skew $ t_{DPLH_TTL} - t_{DPHL_TTL} $ | t_{HLSKEW_TTL} | TTL mode, $C_L = 15pF$, $0V \leq V_{IN} \leq +5V$, Figures 1, 2 | 0 | | 52 | ns |
| Digital Input (DI) Maximum Switching Rate | SR_{DY} | DI mode | 400 | | | kHz |
| DI Propagation Delay | t_{DPLH_DY} | DI mode, $C_L = 15pF$, $0V \leq V_{IN} \leq +24V$, Figures 1, 2 | | | 300 | ns |
| | t_{DPHL_DY} | | | | 300 | |

Switching Characteristics (continued)

(V_{CC} = 5V±10%, V_L = 1.62V to V_{CC}, T_A = -40°C to +125°C unless otherwise noted. Typical values are at V_{CC} = 5V, V_L = 3.3V, T_A = +25°C.) (Notes 2, 3)

| PARAMETER | SYMBOL | CONDITIONS | MIN | TYP | MAX | UNITS |
|--|---------------------------|---|----------|------|------|-------|
| DI Receiver Propagation Delay Skew t _{DPLH_DY} - t _{DPHL_DY} | t _{RSKEW_DY} | DI mode, C _L = 15pF, 0V ≤ V _{IN} ≤ +24V, Figures 1, 2 | 0 | | 100 | ns |
| DI Maximum Glitch Duration for Glitch Rejection | t _{GL} | DI/TTL _I is high or low | | | 80 | ns |
| DI Admitted Pulse Duration | t _{PASS} | DI/TTL _I is high or low | 300 | | | ns |
| RECEIVER (DI2, DI3) (Note 5) | | | | | | |
| Digital Input (DI) Maximum Switching Rate | SR _{DI} | DI mode | 20 | | | kHz |
| DI Propagation Delay | t _{DPLH_DI} | DI mode, C _L = 15pF, 0V ≤ V _{IN} ≤ +24V, Figures 1, 2 | | | 5 | μs |
| | t _{DPHL_DI} | | | | 5 | |
| DI Receiver Propagation Delay Skew (t _{DPLH_DI} - t _{DPHL_DI}) | t _{RSKEW_DI} | DI mode, C _L = 15pF | | 60 | | ns |
| Maximum Glitch Duration for Glitch Rejection | t _{GL} | DI mode, DI/TTL _I is high or low | | | 80 | ns |
| Admitted Pulse Length | t _{PASS} | DI mode, DI/TTL _I is high or low | 350 | | | ns |
| TTL Maximum Switching Rate | SR _{DI_TTL} | TTL mode | 20 | | | kHz |
| TTL Receiver Propagation Delay | t _{DPLH_DITTL} | TTL mode, C _L = 15pF, 0V ≤ V _{IN} ≤ +5V, Figures 1, 2 | | | 5 | μs |
| | t _{DPHL_DITTL} | | | | 5 | |
| TTL Receiver Propagation Delay Skew (t _{DPLH_DITTL} - t _{DPHL_DITTL}) | t _{HLSKEW_DITTL} | TTL mode, C _L = 15pF, Figures 1, 2 | | 80 | | ns |
| FAULT DETECTION (AFAULT, BFAULT, ZFAULT, D2FAULT/IRQ, D3FAULT/SDO) (Note 5) | | | | | | |
| Differential Fault Propagation Delay to <u>FAULT</u> Output Active | t _{DFLH} | R _{FAULT} = 5kΩ, C _{FAULT} = 15pF, RS-422 and DHTL modes, Figures 1, 4 | FLTR = 0 | | 18 | μs |
| | | | FLTR = 1 | | 1400 | |
| | FLTR = 0 | | | 6 | | |
| | FLTR = 1 | | | 1400 | | |
| Differential Slew Rate to Avoid Fault Alarm Output | | R _{FAULT} = 5kΩ, C _{FAULT} = 15pF, FLTR = 0, RS-422 and D-HTL modes, Figures 1, 4 | 1 | | | V/μs |
| Single Ended Propagation Delay to <u>FAULT</u> Output Active | t _{SEFLH} | R _{FAULT} = 5kΩ, C _{FAULT} = 15pF, all modes | | | 1.4 | ms |
| | t _{SEFHL} | | | | 1.4 | |

Switching Characteristics (continued)

($V_{CC} = 5V \pm 10\%$, $V_L = 1.62V$ to V_{CC} , $T_A = -40^\circ C$ to $+125^\circ C$ unless otherwise noted. Typical values are at $V_{CC} = 5V$, $V_L = 3.3V$, $T_A = +25^\circ C$.) (Notes 2, 3)

| PARAMETER | SYMBOL | CONDITIONS | MIN | TYP | MAX | UNITS |
|--|-------------|--|------------------|-----|-----|-------|
| SPI TIMING (Figure 5) | | | | | | |
| SNGL/CLK Clock Period | t_{CH+CL} | | 80 | | | ns |
| SNGL/CLK Pulse-Width High | t_{CH} | | 25 | | | ns |
| SNGL/CLK Pulse-Width Low | t_{CL} | | 25 | | | ns |
| HITH/ \overline{CS} Fall to SNGL/CLK Rise Time | t_{CSS} | | 15 | | | ns |
| TTL/SDI Hold Time | t_{DH} | | 15 | | | ns |
| TTL/SDI Setup Time | t_{DS} | | 15 | | | ns |
| Output Data Propagation Delay | t_{DO} | $C_L = 10pF$, SNGL/CLK falling-edge to $\overline{D3FAULT}/SDO$ stable. | $V_L \geq 1.62V$ | | 32 | ns |
| | | | $V_L \geq 3.3V$ | | 28 | |
| $\overline{D3FAULT}/SDO$ Rise and Fall Times | t_{FT} | Rising | $V_L = 1.62V$ | 24 | | ns |
| | | | $V_L = 3.3V$ | 2 | | |
| | | Falling | $V_L = 1.62V$ | 11 | | |
| | | | $V_L = 3.3V$ | 1 | | |
| HITH/ \overline{CS} Hold Time | t_{CSH} | $V_L = 1.62V$ or $3.3V$ | 10 | | ns | |
| | | $V_L = 5.5V$ | 5 | | | |
| HITH/ \overline{CS} Pulse-Width High | t_{CSPW} | $V_L = 1.62V$ or $3.3V$ | 10 | | ns | |
| | | $V_L = 5.5V$ | 5 | | | |

Note 2: All devices are 100% production tested at $T_A = +25^\circ C$. Specifications over temperature are guaranteed by design.

Note 3: Currents into the device are positive; all currents out the device are negative. All voltages are referenced to ground, unless otherwise noted.

Note 4: In pin-control mode, $\overline{D3FAULT}/SDO$ is open-drain. In SPI mode, $\overline{D3FAULT}/SDO$ is a push-pull output.

Note 5: Capacitive load includes test probe and fixture capacitance.

Test Circuits and Waveforms

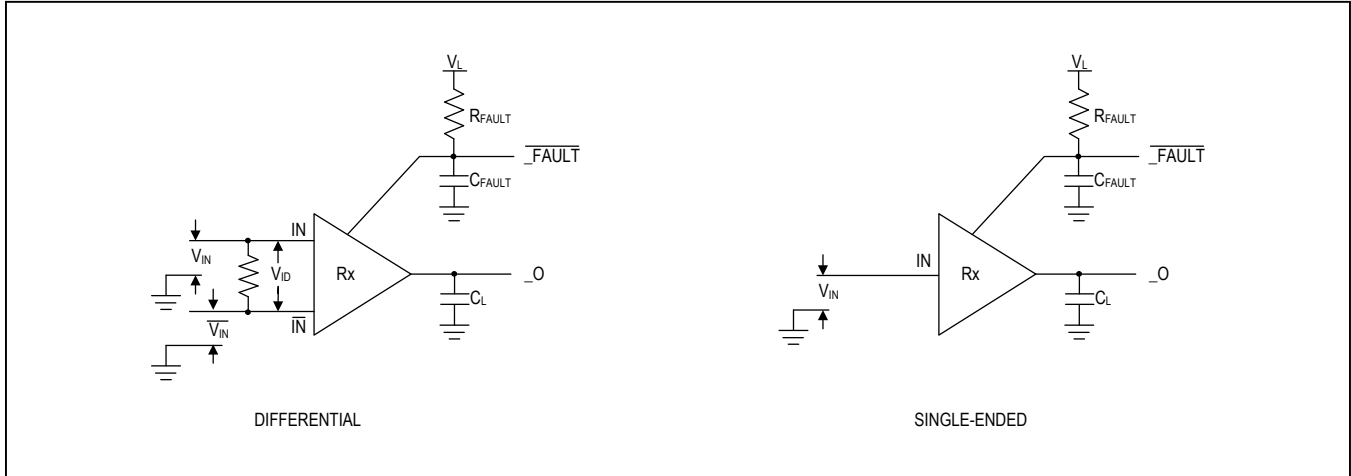

Figure 1. Receiver Test Circuit

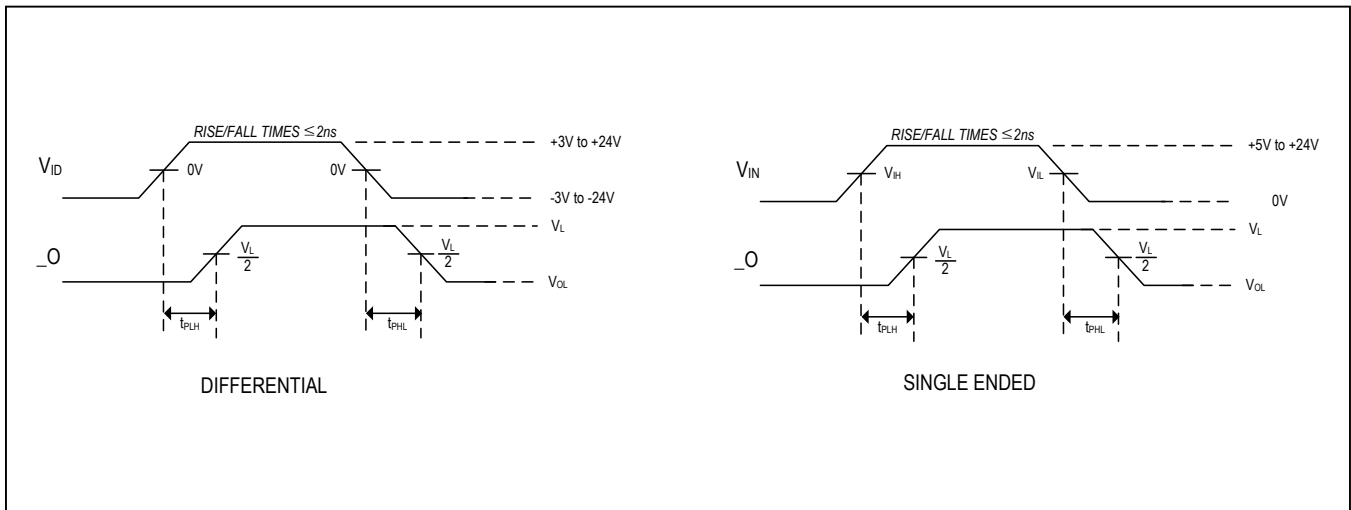

Figure 2. Receiver Propagation Delay

Test Circuits and Waveforms (continued)

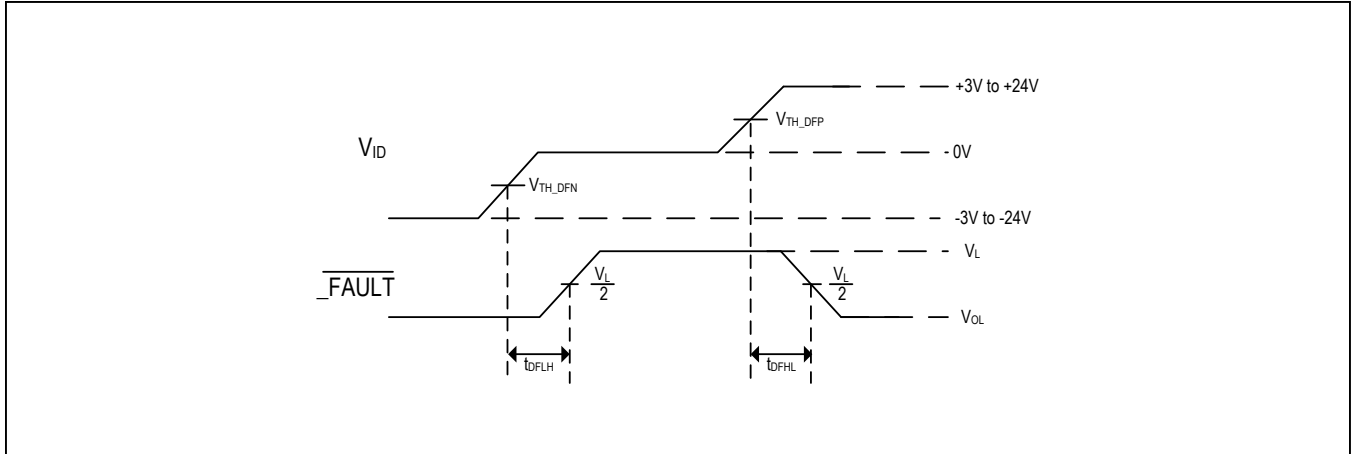

Figure 3. Fault Detection Timing

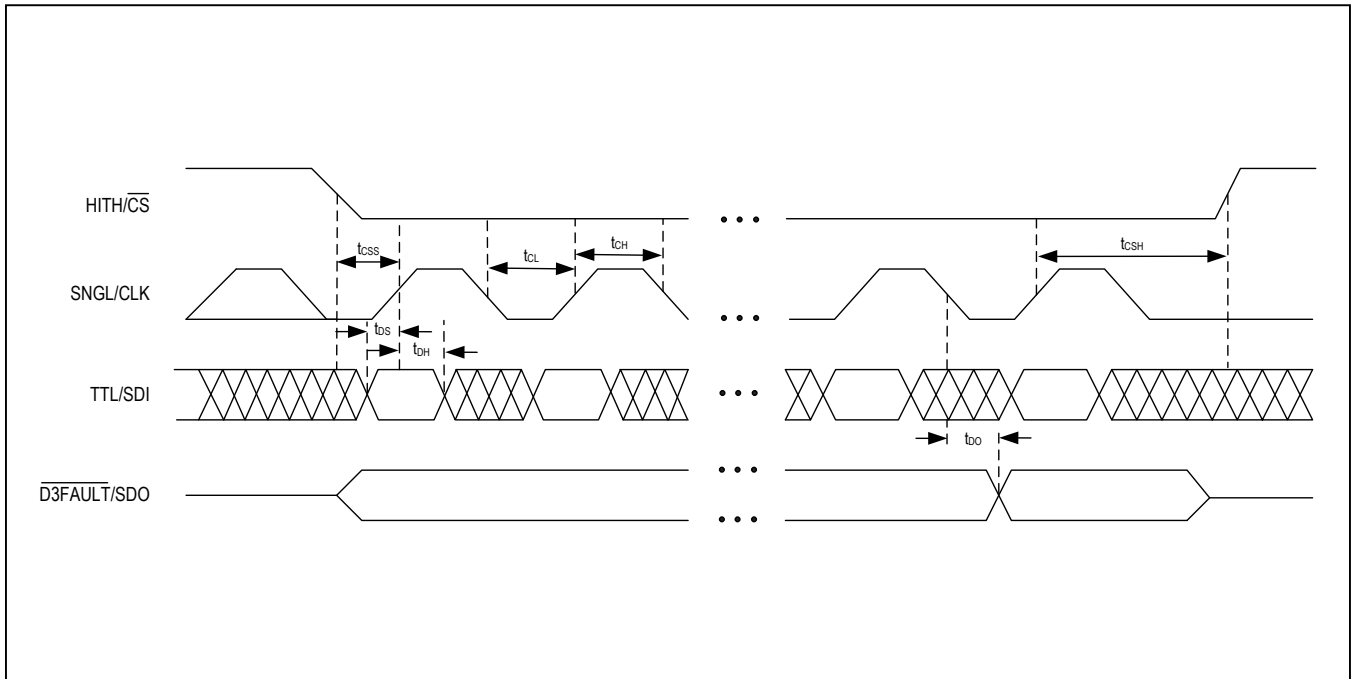
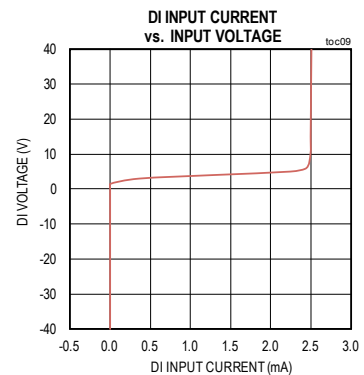
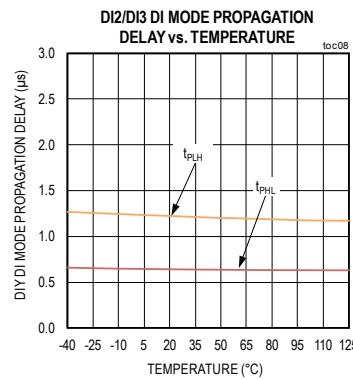
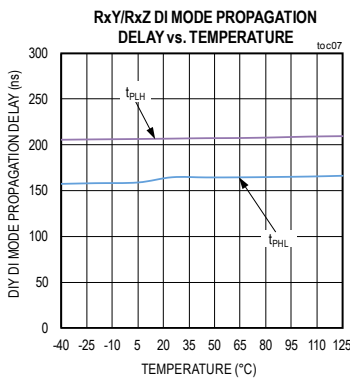
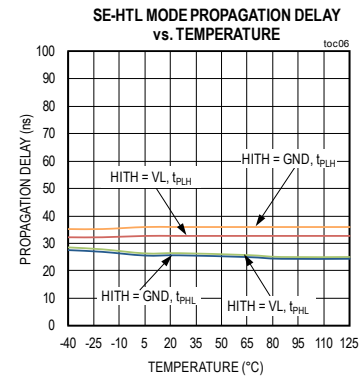
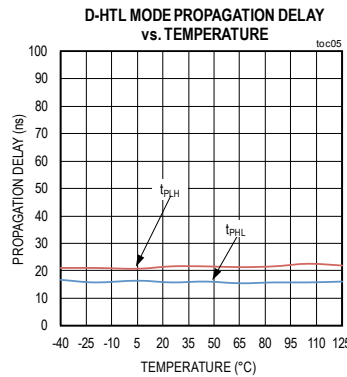
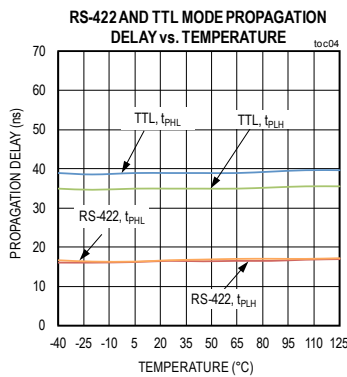
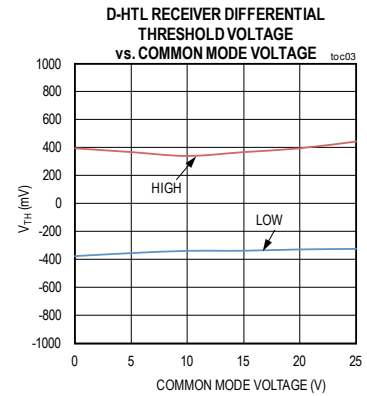
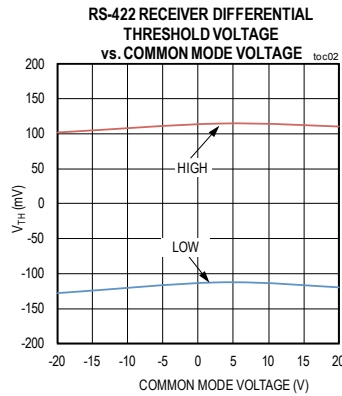
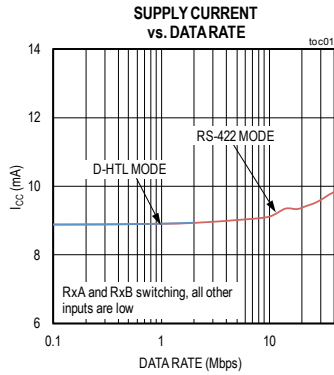

Figure 4. SPI Timing Diagram

Typical Operating Characteristics

($V_{CC} = 5V$, $V_L = 3.3V$, $T_A = +25^\circ C$, unless otherwise noted.)



Typical Operating Characteristics (continued)

(V_{CC} = 5V, V_L = 3.3V, T_A = +25°C, unless otherwise noted.)

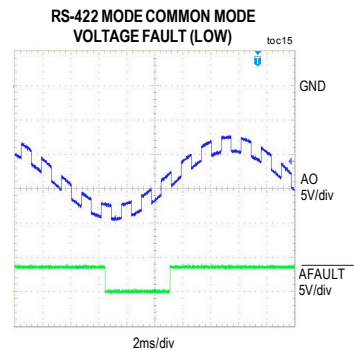
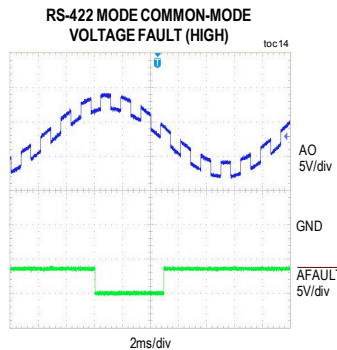
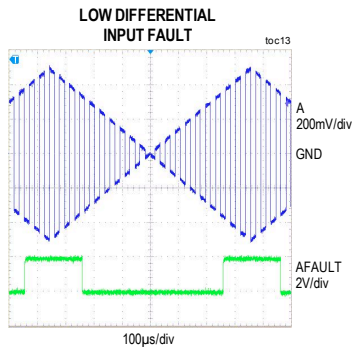
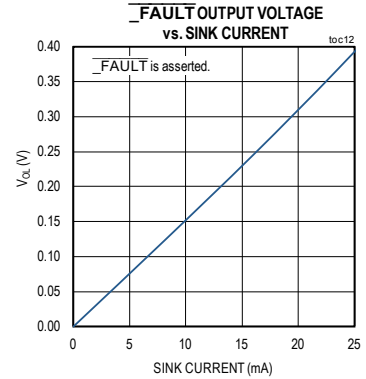
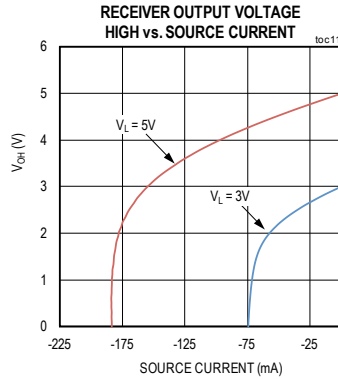
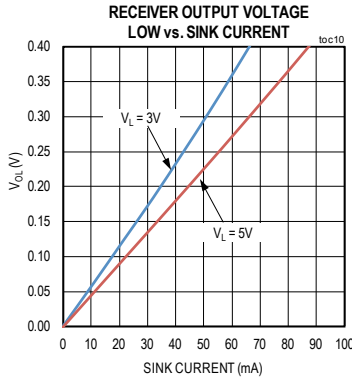

Pin Configuration

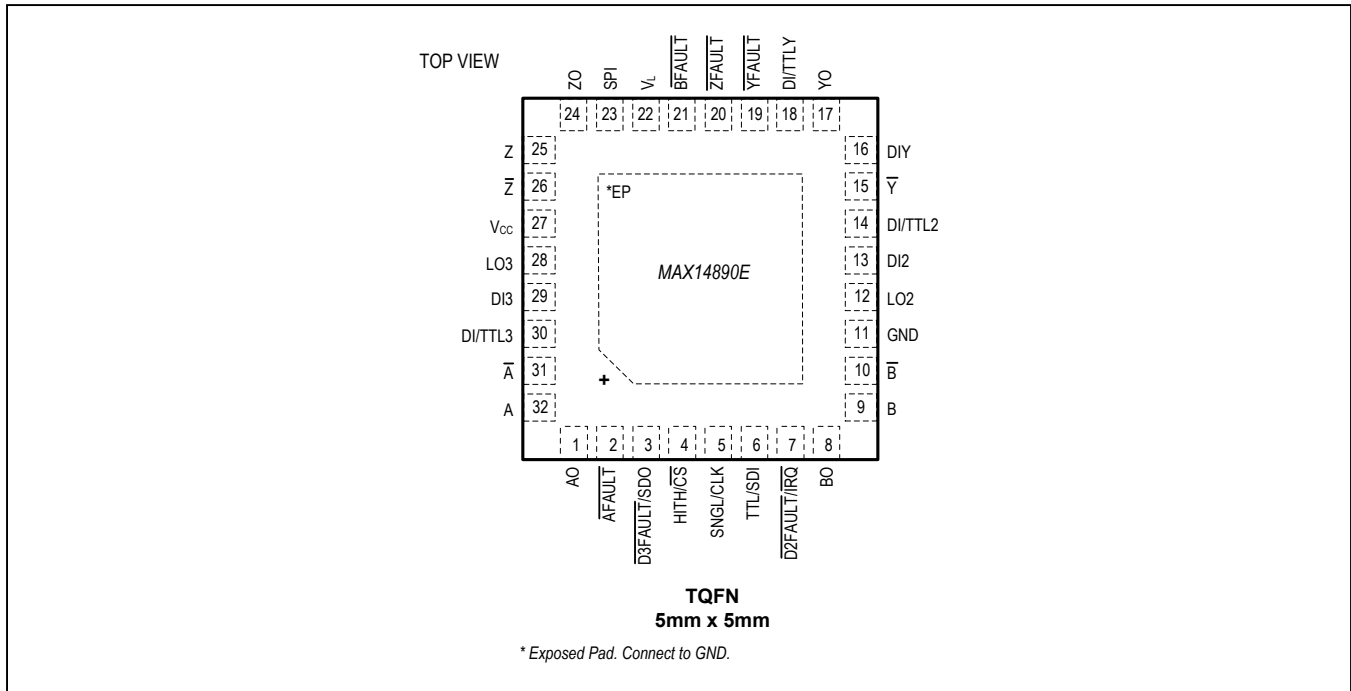

Pin Description

| PIN | NAME | FUNCTION |
|-----|--|---|
| 1 | AO | Noninverting RS-422/HTL/TTL Receiver Input A. |
| 2 | $\overline{\text{AFAULT}}$ | Open-Drain Fault Output for Receiver A. $\overline{\text{AFAULT}}$ asserts low during a fault condition on receiver A (RxA) . See the <i>Detecting Faults</i> section for more information. |
| 3 | $\overline{\text{D3FAULT}}/\text{SDO}$ | Receiver D3 Open-Drain Fault Output/SPI Serial Data Out. In pin mode (SPI is low), $\overline{\text{D3FAULT}}/\text{SDO}$ asserts low during a fault condition on the D3 receiver. See the <i>Detecting Faults</i> section for more information. In SPI mode (SPI is high), $\overline{\text{D3FAULT}}/\text{SDO}$ is the SPI serial data output and is in a push-pull configuration. $\overline{\text{D3FAULT}}/\text{SDO}$ is high-impedance in SPI mode with HITH/ $\overline{\text{CS}}$ is high. |
| 4 | HITH/ $\overline{\text{CS}}$ | Single-Ended HTL Threshold Select Input/SPI Chip Select. In pin mode (SPI is low), HITH/ $\overline{\text{CS}}$ sets the input thresholds for the single-ended HTL signals. In this mode, drive HITH/ $\overline{\text{CS}}$ high to enable the 12V (typ) thresholds or drive HITH/ $\overline{\text{CS}}$ low to enable the 7V (typ) thresholds. In SPI mode (SPI is high), HITH/ $\overline{\text{CS}}$ is the SPI chip select input. |
| 5 | SNGL/CLK | Single-Ended Receiver Input Select/SPI Clock Input. In pin mode (SPI is low), SNGL/CLK selects the mode for the inputs of receivers A,B, and Z. In this mode, drive SNGL/CLK high to enable the receivers for single-ended TTL or HTL operation. Drive SNGL/CLK low for differential (RS-422 or DHTL) operation. See the <i>Truth Tables</i> for more information. In SPI mode (SPI is high), SNGL/CLK is the SPI clock input. |
| 6 | TTL/SDI | TTL Mode Select Input/SPI Serial Data Input. In pin mode (SPI is low), enables TTL operation for receivers A, B, and Z. In this mode, drive TTL/SDI high to enable TTL or RS-422 operation. Drive TTL/SDI low to select DHTL or SEHTL operation for those receivers. In SPI mode (SPI is high), TTL/SDI is the serial data input. |

Pin Description (continued)

| PIN | NAME | FUNCTION |
|-----|-------------------------------------|--|
| 7 | $\overline{D2FAULT}/\overline{IRQ}$ | Receiver D2 Open-Drain Fault Output/SPI IRQ Output. In pin mode (SPI is low), $\overline{D2FAULT}/\overline{IRQ}$ asserts low during a fault condition on the D2 receiver (RxD2). In SPI mode (SPI is high), $\overline{D2FAULT}/\overline{IRQ}$ asserts low when a fault bit is set. See the <i>Serial SPI Control</i> section for more information. |
| 8 | BO | Receiver B Output. |
| 9 | B | Non-Inverting RS-422/HTL/TTL Input for Receiver B. |
| 10 | \overline{B} | Inverting Input for Receiver B. \overline{B} is only used when differential mode is enabled. |
| 11 | GND | Ground |
| 12 | LO2 | Receiver DI2 Output. |
| 13 | DI2 | Digital/TTL Input for DI2 Receiver. |
| 14 | DI/TTL2 | Digital Input/TTL Select Input for DI2 Receiver. See the <i>Truth Tables</i> for more information. DI/TTL2 has no function in SPI mode (SPI is high). |
| 15 | \overline{Y} | Inverting RS-422 Input for Receiver Y. \overline{Y} is used only when differential mode is enabled. |
| 16 | DIY | Digital/TTL/Non-inverting RS-422 Input for Receiver Y. |
| 17 | YO | Receiver Y Output. |
| 18 | DI/TTLY | Digital Input/TTL/RS-422 Select Input for Receiver Y. See the <i>Truth Tables</i> for more information. DI/TTLY has no function in SPI mode (SPI is high). |
| 19 | \overline{YFAULT} | Open-Drain Fault Output for Receiver Y. \overline{YFAULT} asserts low during a fault condition on receiver Y. See the Fault Conditions section for more information. |
| 20 | \overline{ZFAULT} | Open-Drain Fault Output for Receiver Z. \overline{ZFAULT} asserts low during a fault condition on receiver Z. See the Fault Conditions section for more information. |
| 21 | \overline{BFAULT} | Open-Drain Fault Output for Receiver B. \overline{BFAULT} asserts low during a fault condition on receiver B. See the Fault Conditions section for more information. |
| 22 | V_L | Logic Interface Supply Input. V_{CC} must always be greater than or equal to V_L . |
| 23 | SPI | Serial/Parallel Select Input. Drive SPI low to enable pin-mode operation. Drive SPI high to enable SPI mode operation. |
| 24 | ZO | Receiver Z Output. |
| 25 | Z | Non-Inverting RS-422/HTL/TTL Input for Receiver Z. |
| 26 | \overline{Z} | Inverting Input for Receiver Z. \overline{Z} is only used when the receiver is configured for differential mode. |
| 27 | V_{CC} | Supply Input. Bypass V_{CC} to ground through a 0.1 μ F capacitor as close to the device as possible. V_{CC} must always be greater than or equal to V_L . |
| 28 | LO3 | Receiver D3 Output. |
| 29 | DI3 | Digital/TTL Input for the D3 Receiver. |
| 30 | DI/TTL3 | Digital Input/TTL Select Input for the D3 Receiver. See the <i>Truth Tables</i> for more information. DI/TTL3 has no function in SPI mode (SPI is high). |
| 31 | \overline{A} | Inverting Input for Receiver A. \overline{A} is used only when differential mode is enabled. |
| 32 | A | Non-inverting RS-422/HTL/TTL Input for Receiver A. |
| - | EP | Exposed pad. Connect EP to ground. Not intended as the primary ground connection. |

Truth Tables

Table 1. RxA, RxB, RxZ and RxY Receiver Settings (Pin-Control Mode)

| INPUTS | | | RECEIVER OPERATION | |
|----------|---------|---------|--------------------|--------|
| SNGL/CLK | TTL/SDI | DI/TTLY | RxA, RxB, RxZ | RxY |
| L | L | L | D-HTL | TTL |
| L | L | H | D-HTL | DI |
| L | H | L | RS-422 | RS-422 |
| L | H | H | RS-422 | DI |
| H | L | L | SE-HTL | TTL |
| H | L | H | SE-HTL | DI |
| H | H | L | TTL | TTL |
| H | H | H | TTL | DI |

Table 2. RxD2 Receiver Settings (Pin-Control Mode)

| DI/TTL2 | RxD2 MODE OF OPERATION |
|---------|------------------------|
| L | TTL |
| H | DI |

Table 3. RxD3 Receiver Input Settings (Pin-Control Mode)

| DI/TTL3 | RxD3 MODE OF OPERATION |
|---------|------------------------|
| L | TTL |
| H | DI |

Table 4. DI Mode Receiver Logic (RxY, RxD2, RxD3)

| DI ₁ , DI ₂ , DI ₃ | YO, LO ₂ , LO ₃ | $\overline{\text{FAULT}}$ |
|---|---------------------------------------|---------------------------|
| $-40V < V_{IN} \leq -18V$ | L | L |
| $-18V < V_{IN} < -15V$ | L | Indeterminate |
| $-15V < V_{IN} < +6V$ | L | H |
| $+6V < V_{IN} < +8V$ | Indeterminate | H |
| $+8V \leq V_{IN} < +40V$ | H | H |

Table 5. Single-Ended TTL Mode Receiver Logic

| INPUT (A, B, Z, DI1, DI2, DI3) | OUTPUT (AO, BO, ZO, YO, LO2, LO3) | $\overline{\text{FAULT}}$ | FAULT CONDITION |
|-----------------------------------|--------------------------------------|---------------------------|------------------|
| $-40V < V_{IN} < -18V$ | L | L | Low Input Fault |
| $-18V < V_{IN} < -15V$ | L | Indeterminate | Indeterminate |
| $-15V < V_{IN} < +0.8V$ | L | H | No Fault |
| $+0.8V < V_{IN} < +2.0V$ | Indeterminate | H | No Fault |
| $+2.0V \leq V_{IN} < +15V$ | H | H | No Fault |
| $+15V \leq V_{IN} < +18V$ | H | Indeterminate | Indeterminate |
| $+18V \leq V_{IN} < +40V$ | H | L | High Input Fault |

Table 6. SE-HTL Mode Receiver Logic (RxA, RxB, RxZ)

| HITH | INPUT VOLTAGE (A, B, Z) | OUTPUT STATE (AO, BO, ZO) | $\overline{\text{FAULT}}$ | FAULT CONDITION |
|------|----------------------------|------------------------------|---------------------------|-----------------|
| L | $-40V < V_{IN} < -18V$ | L | L | Low Input Fault |
| L | $-18V < V_{IN} < -15V$ | L | Indeterminate | Indeterminate |
| L | $-15V < V_{IN} < +6V$ | L | H | No Fault |
| L | $+6V < V_{IN} < +8V$ | Indeterminate | H | No Fault |
| L | $+8V \leq V_{IN} < +40V$ | H | H | No Fault |
| H | $-40V < V_{IN} < -18V$ | L | L | Low Input Fault |
| H | $-18V < V_{IN} < -15V$ | L | Indeterminate | Indeterminate |
| H | $-15V < V_{IN} < +11V$ | L | H | No Fault |
| H | $+11V < V_{IN} < +13V$ | Indeterminate | H | No Fault |
| H | $+13V \leq V_{IN} < +40V$ | H | H | No Fault |

Table 7. D-HTL Mode Receiver Logic (RxA, RxB, RxZ)

| DIFFERENTIAL INPUT VOLTAGE | SINGLE-ENDED INPUT VOLTAGE (A, \bar{A} , B, \bar{B} , Z, \bar{Z}) | OUTPUT STATE (AO, BO, ZO) | $\overline{\text{FAULT}}$ | FAULT CONDITION |
|--------------------------------|--|---------------------------|---------------------------|--------------------------------------|
| $V_{ID} > +2V$ | $-10V < V_{SE}$ | H | H | No Fault |
| $+1.2V < V_{ID} < +2V$ | | H | Indeterminate | Indeterminate |
| $-0.9V \leq V_{ID} \leq +0.9V$ | | Indeterminate | L | Low Differential Input Voltage Fault |
| $-2V \leq V_{ID} \leq -1.2V$ | | L | Indeterminate | Indeterminate |
| $V_{ID} \leq -2V$ | | L | H | No Fault |
| X | $-18V < V_{SE} < -15V$ | VALID* | Indeterminate | Single-Ended Voltage Fault |
| X | $-40V < V_{SE} < -18V$ | VALID* | L | Single-Ended Voltage Fault |

X = Don't care

*Receiver operates normally, although thresholds may deviate from limits in Electrical Characteristics Table

Table 8. RS-422 Mode Receiver Logic (RxA, RxB, RxZ, RxY)

| DIFFERENTIAL INPUT VOLTAGE | SINGLE-ENDED INPUT VOLTAGE (A, \bar{A} , B, \bar{B} , Z, \bar{Z} , Y, \bar{Y}) | OUTPUT STATE (AO, BO, ZO, YO) | $\overline{\text{FAULT}}$ | FAULT CONDITION |
|-----------------------------------|---|-------------------------------|---------------------------|--------------------------------------|
| $V_{ID} > +0.45V$ | $-20V \leq V_{SE} \leq +20V$ | H | H | No Fault |
| $+0.27V < V_{ID} < +0.45V +0.45V$ | | H | Indeterminate | Indeterminate |
| $-0.2V \leq V_{ID} \leq +0.2V$ | | Indeterminate | L | Low Differential Input Voltage Fault |
| $-0.45V \leq V_{ID} \leq -0.27V$ | | L | Indeterminate | Indeterminate |
| $V_{ID} \leq -0.45V$ | | L | H | No Fault |
| X | $-40V < V_{SE} < -18V$ | VALID* | L | Single-Ended Voltage Fault |
| X | $-18V < V_{SE} < -15V$ | VALID* | Indeterminate | Single-Ended Indeterminate Voltage |
| X | $+15V < V_{SE} < +18V$ | VALID* | Indeterminate | Single-Ended Indeterminate Voltage |
| X | $+18V < V_{SE} < +40V$ | VALID* | L | Single-Ended Voltage Fault |

X = Don't care

*Receiver operates normally, although thresholds may deviate from limits in Electrical Characteristics Table

Detailed Description

The MAX14890E is an incremental encoder receiver containing four differential receivers and two single-ended receivers. All four differential receivers support RS-422 and TTL operation. Three of these differential receivers can be configured for differential and single-ended HTL operation. In RS-422 mode, these receivers feature a wide common mode input range of -20V to +20V making it resilient to common mode noise.

The auxiliary IEC 61131-2 Type-1/Type-3 24V digital inputs allow connection of proximity sensors. The digital inputs can be individually configured for TTL operation.

All receiver input signals are fault protected to voltage shorts in the $\pm 40V$ range. Per channel fault detection provides warning of irregular conditions, like small differential signals, shorts, opens, over- and undervoltages.

SPI or Pin-Control Mode Selection

The MAX14890E provides a selectable SPI or pin interface to set the input thresholds and functionality of the receivers. Drive SPI high to use the SPI interface. Drive SPI low to use the pin interface.

SPI mode allows for higher flexibility by allowing individual receiver configuration. See the [Serial SPI Control](#) section for more information.

TTL Operation

All 6 of the receivers can be configured for single-ended TTL operation. Complimentary/unused inputs can be left unconnected in all single-ended modes like TTL, DI, and SE-HTL.

In pin-control mode, drive the TTL/SDI and SNGL/CLK inputs high to enable TTL operation on the RxA, RxB, and RxZ receivers. To enable TTL operation on RxY receiver, set DI/TTL1 low. To enable TTL operation on the RxD2 or RxD3 receivers, drive the DI/TTL2 or DI/TTL3 inputs low. See the [Truth Tables](#) section for more information.

In SPI mode, each receiver can be enabled for TTL operation individually. Set the associated `_SNGL` and `_TTL` bits to enable TTL mode for each receiver. See the [Serial SPI Control](#) section for more information.

Single-Ended HTL Operation (SE-HTL)

The RxA, RxB, and RxZ receivers can be configured for single-ended HTL operation. Complimentary/unused inputs can be left unconnected in all single-ended modes (TTL, DI, and SE-HTL).

In pin-control mode, drive the TTL/SDI input low and the SNGL/CLK input high to enable SE-HTL mode on the RxA, RxB, and RxZ receivers.

In SPI mode, each of the RxA, RxB, and RxZ receivers can be individually enabled for SE-HTL functionality. See the [Serial SPI Control](#) section for more information.

Differential HTL (D-HTL) Operation

The RxA, RxB, and RxZ receivers can be configured for D-HTL operation. Input signals up to $\pm 40V$ can be accepted in D-HTL mode.

In pin-control mode, set the SNGL/CLK and TTL/SDI inputs low to enable D-HTL functionality for the RxA, RxB, and RxZ receivers. See the [Truth Tables](#) section for more information.

In SPI mode, each of the RxA, RxB, and RxZ receivers can be individually enabled for D-HTL functionality. See the [Serial SPI Control](#) section for more information.

RS-422 Operation

The RxA, RxB, RxZ, and RxY receivers can be configured for RS-422 operation. These receivers include a wide common-mode input range (-20V to +20V) in this mode.

In pin-control mode, set the SNGL/CLK input low and the TTL/SDI input high to enable RS-422 functionality for the RxA, RxB, RxZ, and RxY receivers. See the [Truth Tables](#) section for more information.

In SPI mode, each receiver can be individually enabled for RS-422 functionality. See the [Serial SPI Control](#) section for more information.

Equivalent Input Circuit

In RS-422, TTL, SE-HTL, and D-HTL modes, the inputs pins have the equivalent circuit shown in Figure 5. When the RxA, RxB, RxZ, and/or RxY inputs are configured for TTL mode and are open/not connected, the input is pulled up to 2.64V (typ), resulting in a logic high on the receiver output.

RxD2 and RxD3 have high impedance inputs in TTL mode ([Figure 6](#)). Leaving DI2 or DI3 unconnected in this mode will result in an unknown logic state on the receiver output.

Detecting Faults

Signal integrity from the encoder is essential for reliable system operation. Degraded signals could cause problems ranging from simple miscounts to loss of position. The MAX14890E detects common RS-422/HTL/TTL/DI faults. These faults include low differential input signals,

open-wire, short-circuits and input voltages that are outside normal operating voltage ranges (below -18V and above +18V). See the [Truth Tables](#) for more information.

Detecting Small Differential Signals

In RS-422 and differential HTL (D-HTL) modes, the receivers detect small DC and AC signals. Small DC signals can occur due to open wires or shorts, both of which are explained in the following sections. Small differential AC signals can result due to cable attenuation of long or inadequate cables, or due to poor wiring.

Detecting Short Circuit and Open-Circuit Faults (RS-422 and D-HTL Operation)

The MAX14890E receivers detect short circuits on the inputs in RS-422 and D-HTL modes. When the A and \bar{A} inputs are shorted together, the differential input voltage is 0V, generating a low differential input voltage fault (Figure 7). Open-circuit detection is similar to detecting a short-circuit condition and relies on the differential termination resistor across the receiver inputs. When an input is open, the termination resistor pulls the non-inverting and inverting inputs to the same voltage, generating a fault condition.

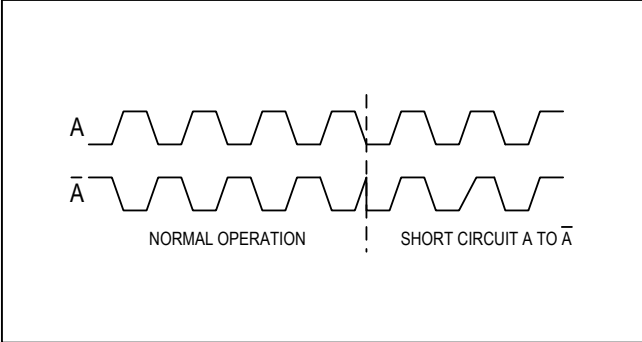

Figure 7. Short Circuit Detection

The $\overline{\text{FAULT}}$ output asserts when either a short-circuit or open-circuit conditions is detected.

Thermal Shutdown

The MAX14890E enters thermal shutdown when the chip temperature rises to above 160°C (typ). Receiver outputs are undefined and the $\overline{\text{FAULT}}$ outputs are off when the device is in thermal shutdown.

Serial SPI Control

SPI Interface

The MAX14890E can be configured and monitored through an SPI interface. The SPI interface allows for greater flexibility for independent receiver mode configuration.

Drive the SPI input high to enable SPI functionality. The $\overline{\text{AFAULT}}$, $\overline{\text{BFAULT}}$, $\overline{\text{ZFAULT}}$, $\overline{\text{YFAULT}}$ and receiver outputs (AO, BO, ZO, YO, LO2 and LO3) are operational in SPI mode. All configuration bits are 0 (default) when SPI is pulled high, setting RxA, RxB, and RxZ in D-HTL mode, RxY in RS-422 mode, and Rx $\overline{\text{D2}}$ and Rx $\overline{\text{D3}}$ in TTL mode. After SPI is pulled high, all $\overline{\text{D3FAULT}}/\text{SDO}$ data is 0s during the first SPI cycle.

The MAX14890E samples the TTL/SDI input on the rising edge of the SNGL/CLK signal, while $\overline{\text{D3FAULT}}/\text{SDO}$ is generated on the falling edge of the SNGL/CLK.

The HITH/ $\overline{\text{CS}}$ SPI chip select input signal features a glitch filter that improves robustness against EMI, requiring a longer setup time.

The MAX14890E must receive at least 16 clock pulses on SNGL/CLK between the HITH/ $\overline{\text{CS}}$ falling edge and the HITH/ $\overline{\text{CS}}$ rising edge (SPI command transfer). If less than 16 pulses are received, the device ignores the TTL/SDI data received. If more than 16 pulses are received, only the last 16 bits of data before HITH/ $\overline{\text{CS}}$ rises are utilized. Figure 8 shows a standard SPI cycle.

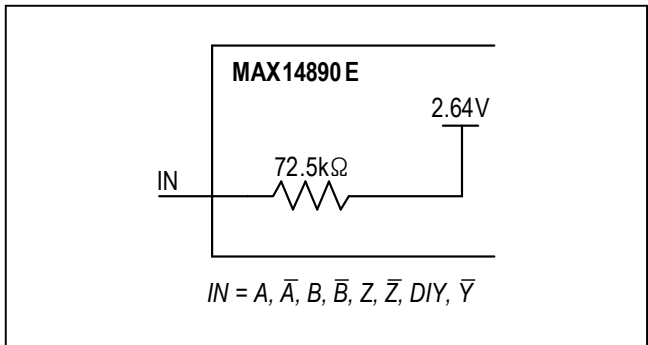

Figure 5. Equivalent Input Circuit for TTL, RS-422, SE-HTL and D-HTL Modes (Rx $\overline{\text{A}}$, Rx $\overline{\text{B}}$, Rx $\overline{\text{Z}}$, Rx $\overline{\text{Y}}$)

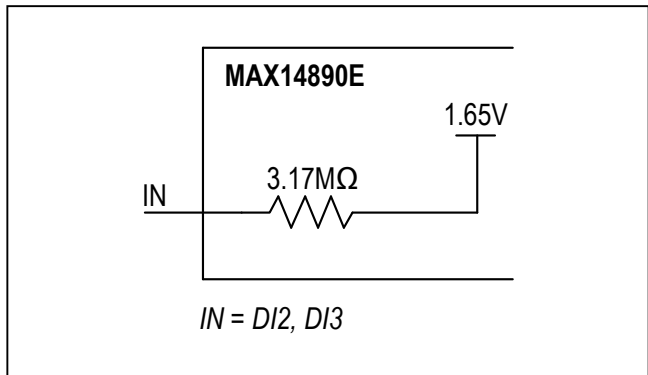

Figure 6. Equivalent Input Circuit for Rx $\overline{\text{D2}}$ and Rx $\overline{\text{D3}}$ in TTL Mode

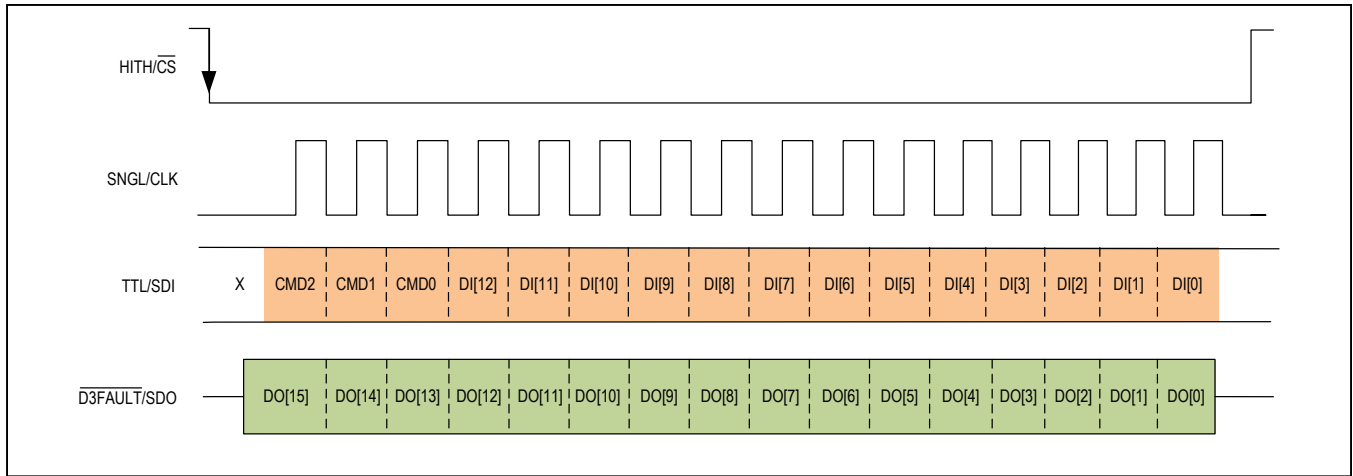

Figure 8. Standard SPI Cycle

The 16 bits of $\overline{D3FAULT}/SDO$ data generated by the MAX14890E depend on the previously received SPI command. If more than 16 SNGL/CLK cycles are present during an SPI cycle, $\overline{D3FAULT}/SDO$ will output the data received on TTL/SDI with a 16 bit latency, allowing for daisy-chain transfers.

Register Functionality

Three command bits (CMD[2:0]) and 13 mode selection bits control the individual receiver input thresholds and output behavior on the MAX14890E in SPI mode. Table 10 shows the functionality of the CMD[2:0] bits.

Change Configuration with Detailed Fault Readback Command (CMD[2:0] = 101)

Write 101 to bits CMD[2:0] to enable configuring the individual receivers through the SPI interface (Figure 9). Bit settings are equivalent to the hardware inputs, HITH/ \overline{CS} ,

TTL/SDI, SNGL/CLK, and DI. See Tables 11-14 for more information.

The HITH bit enables/disables the single-ended HTL thresholds for all receivers set in HTL mode.

See the *Fault Filtering* section for more information on the FLTR bit.

The detailed fault readback consists of 16 $\overline{D3FAULT}/SDO$ bits. The ADFLT, BDFLT, ZDFLT, YDFLT bits are set when a differential fault error occurs for each receiver. The AFLT, AFLT, BFLT, BFLT, ZFLT, ZFLT, YFLT, DIYFLT, D2LFLT, D2HFLT, D3LFLT, D3HFLT bits are set when a single-ended voltage fault occurs for each input. See Table 15.

Table 10. SPI Command Bit Settings

| CMD2 | CMD1 | CMD0 | CHANGES CONFIGURATION? | FUNCTION |
|-------------------------|------|------|------------------------|---|
| 1 | 0 | 1 | YES | Change configuration. New configuration is set by bits DI[13:0]. Read detailed fault status is the next SPI cycle. See the <i>Change Configuration with Detailed Fault Readback Command</i> section for more information. |
| 0 | 1 | 0 | NO | Read current fault output and receiver outputs in next SPI cycle. See the <i>Fault and Receiver Status Command</i> section for more information. |
| 1 | 1 | 1 | NO | Read current configuration in next SPI cycle. Do not change configuration. See the <i>Readback Current Receiver Command</i> section for more information. |
| 000, 001, 011, 100, 110 | | | NO | Read detailed fault status in next SPI cycle. Do not change configuration. See the <i>Detailed Fault Readback</i> section for more information. |

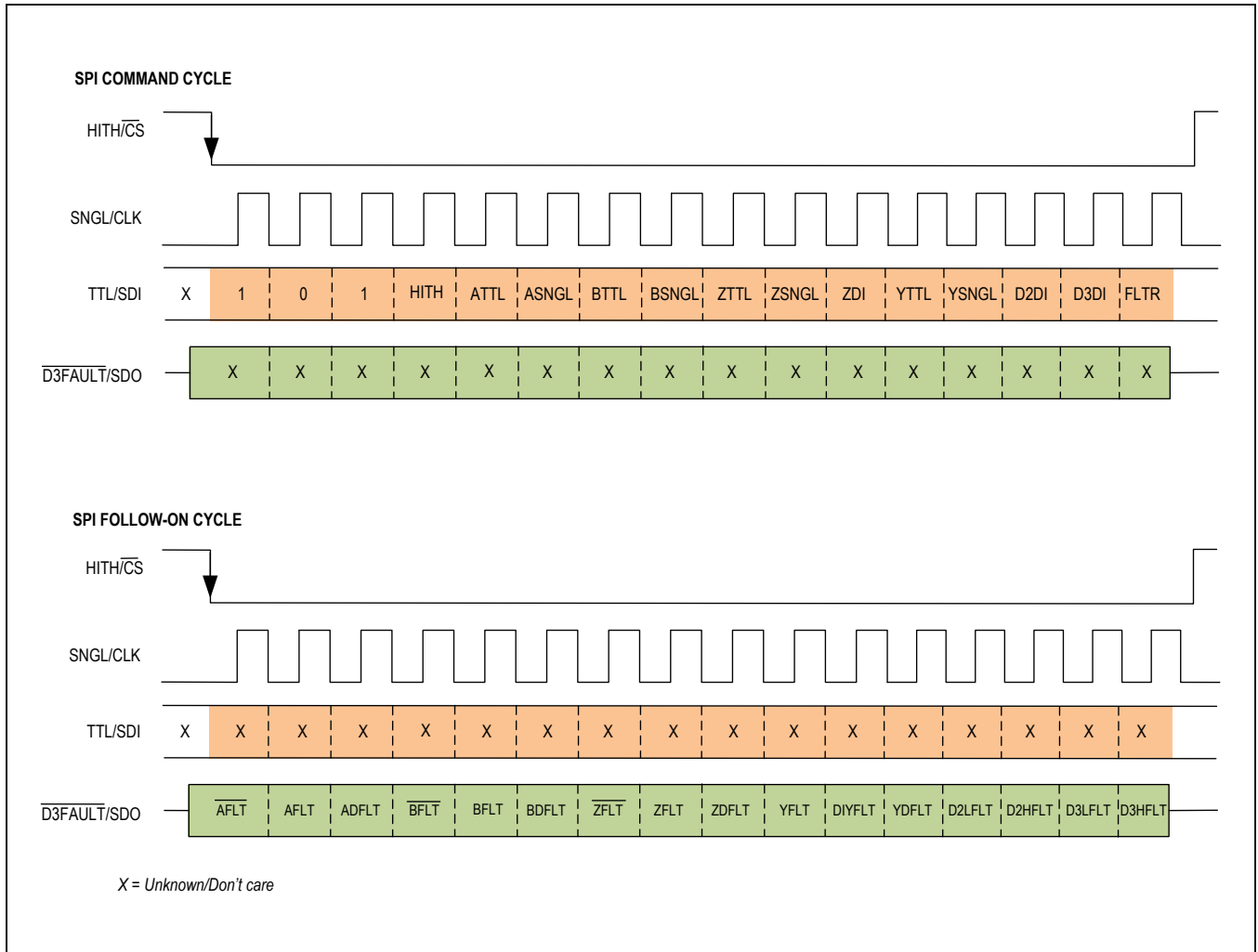

Figure 9. Change Configuration with Detailed Fault Readback SPI Command

Fault and Receiver Status Command (CMD[2:0] = 010)

Write 010 to bits CMD[2:0] to read the fault and receiver output status (Figure 10). The fault and receiver status is latched at the high-to-low transition on HITH/ \overline{CS} of the following SPI cycle and is output on that SPI cycle. The

$_FAULT$ bits are set when a differential or single-ended fault occurs on a receiver. See the [Fault Diagnostics](#) section for more information.

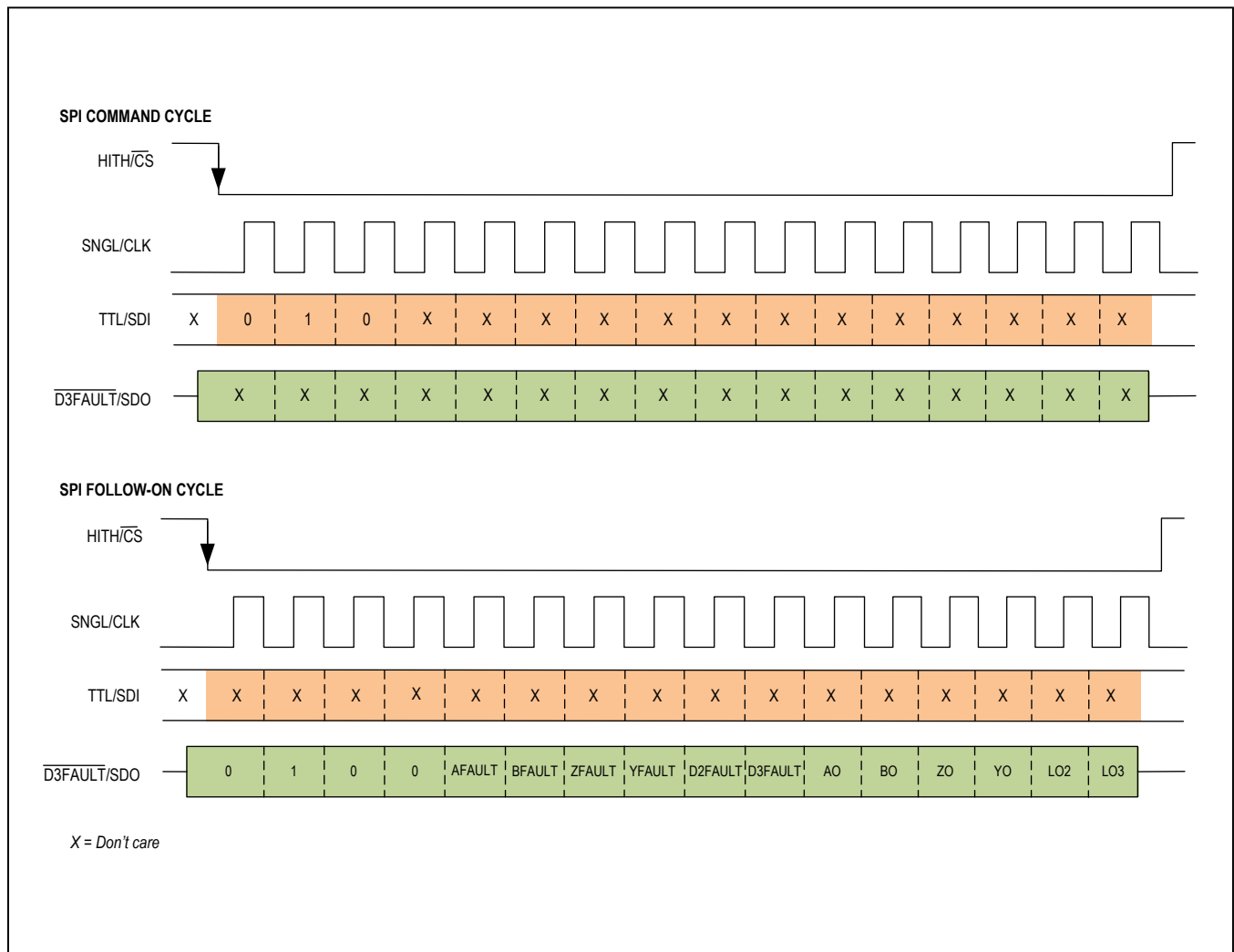

Figure 10. Current Fault and Receiver Status Readback SPI Command

Readback Current Receiver Command (CMD[2:0] = 111)

Write 111 to bits CMD[2:0] to read the current receiver configuration (Figure 11). See Table 11 thru Table 14 for more information.

Fault Filtering

In SPI mode, the interrupt output ($\overline{D3FAULT/IRQ}$) asserts when a fault is detected on any receiver. $\overline{D3FAULT/IRQ}$

and the receiver's \overline{FAULT} output assert 1ms (typ) after the fault is detected.

The 1ms filter is always active for single-ended faults, but can be enabled or disabled for differential faults. Set the global configuration filter bit, FLTR, to 1 to enable the fault filter for differential ($_DFLT$) faults.

Set FLTR = 0 to disable the filter. $\overline{D3FAULT/IRQ}$ and \overline{FAULT} assert 10µs (typ) after the fault is detected when the filter is disabled.

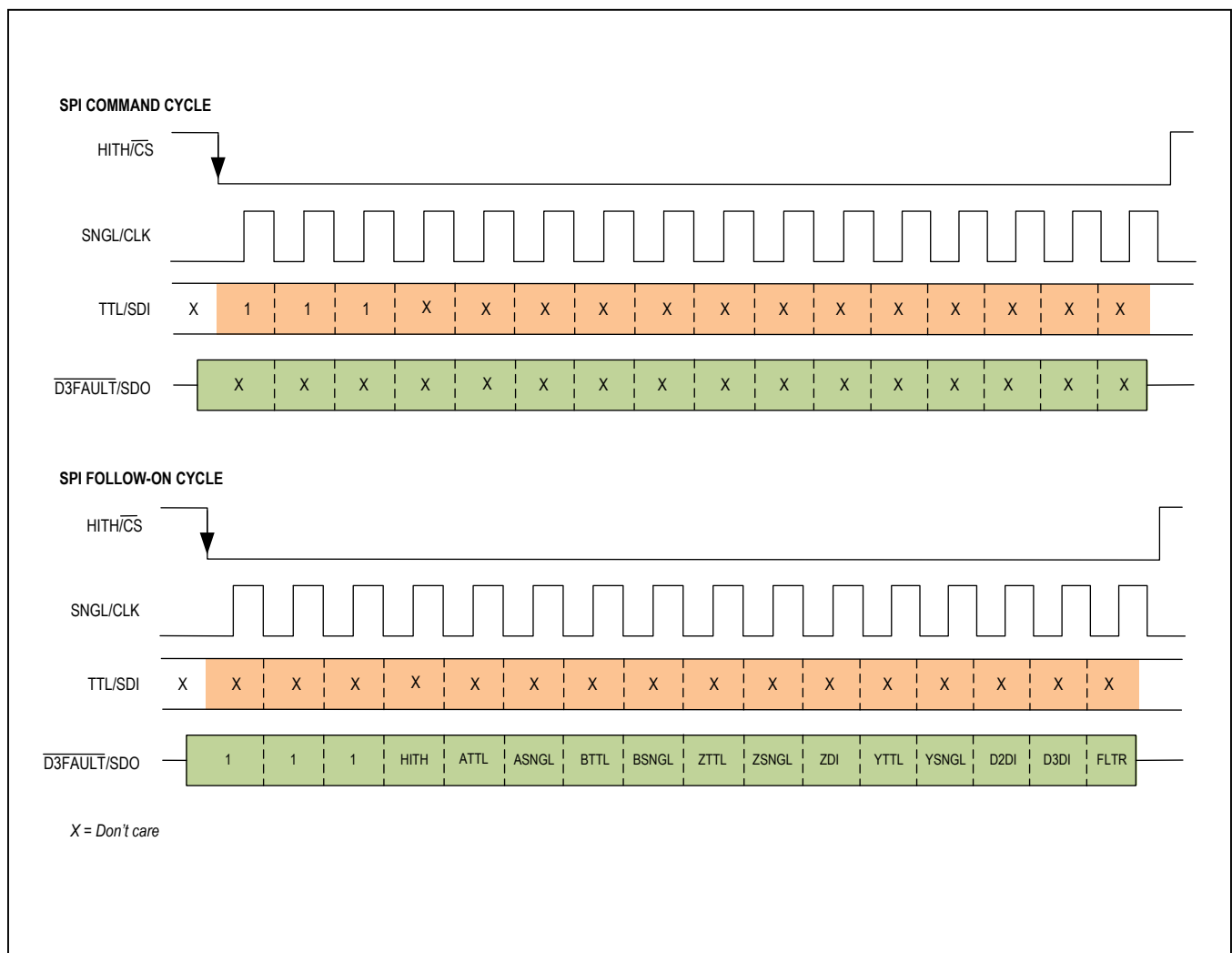

Figure 11. Receiver Configuration Readback SPI Command

Table 11. SPI Mode RxA, RxB Selection Bits

| _SNGL | _TTL | RxA, RxB RECEIVER OPERATION |
|-------|------|-----------------------------|
| 0 | 0 | D-HTL |
| 0 | 1 | RS-422 |
| 1 | 0 | SE-HTL |
| 1 | 1 | TTL |

Table 12. SPI Mode RxZ Selection Bits

| ZTTL | ZSNGL | ZDI | RxZ RECEIVER OPERATION |
|------|-------|-----|------------------------|
| 0 | 0 | 0 | D-HTL |
| 0 | 1 | 0 | SE-HTL |
| 1 | 0 | 0 | RS-422 |
| 1 | 1 | 0 | TTL |
| X | X | 1 | DI |

X = Don't care

Table 13. SPI Mode RxY Selection Bits

| YTTL | YSNGL | RxY RECEIVER OPERATION |
|------|-------|------------------------|
| 0 | 0 | RS-422 |
| 0 | 1 | DI |
| 1 | 0 | RS-422 |
| 1 | 1 | TTL |

Table 14. SPI Mode RxD2, RxD3 Selection Bits

| D_DI | RxD2, RxD3 RECEIVER OPERATION |
|------|-------------------------------|
| 0 | TTL |
| 1 | DI |

Fault Diagnostics

In SPI mode, the interrupt output ($\overline{D3FAULT/IRQ}$) and associated \overline{FAULT} output asserts when a fault is detected on any receiver. \overline{FAULT} deasserts when the fault is removed, but $\overline{D3FAULT/IRQ}$ remains latched until the fault status is read through the SPI interface.

If the fault is not cleared, $\overline{D3FAULT/IRQ}$ deasserts after the SPI read command, but the associated fault bit and \overline{FAULT} output remain asserted.

Applications Information

Cable Termination

Transmission line termination is required for RS-422, HTL, and TTL high-speed signals on long cables. For RS-422 and TTL signal levels, 120Ω termination is commonly used to match the characteristic impedance of the cable. For HTL signals, 270Ω/100pF AC-termination with a series RC can be applied to reduce power dissipation.

Figure 12 shows a sample circuit of a termination scheme to suit all of these operating modes. The 270Ω termination can be permanently left in for all operating modes. For high-speed RS-422 and TTL signals, the cable should be terminated by its characteristic impedance to reduce reflections. This can be done by switching in the parallel resistor in these modes using a beyond-the-rails switch like the MAX14777.

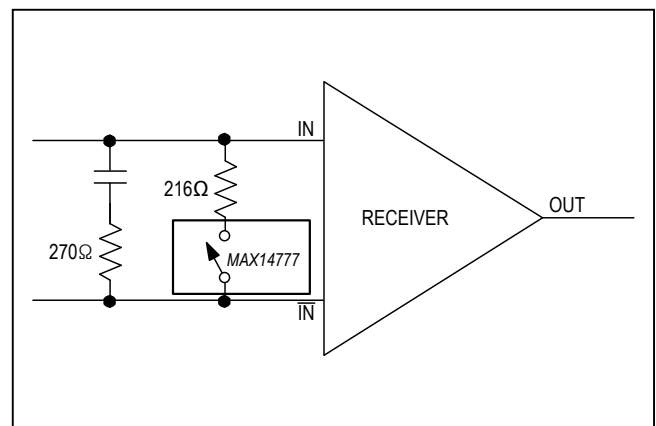

Figure 12. Sample Termination Scheme for HTL, RS-422, and TTL modes

Table 15. Detailed Fault Readback Bit Status

| BIT | NAME | DESCRIPTION |
|-----|--------------------------|---|
| 15 | $\overline{\text{AFLT}}$ | 0 = No fault asserted. 1 = Single-ended fault on $\overline{\text{A}}$ detected by the RxA receiver. |
| 14 | AFLT | 0 = No fault asserted. 1 = Single-ended fault on A detected by the RxA receiver. |
| 13 | ADFLT | 0 = No fault asserted. 1 = Differential fault detected on RxA. |
| 12 | $\overline{\text{BFLT}}$ | 0 = No fault asserted. 1 = Single-ended fault on $\overline{\text{B}}$ detected by the RxB receiver. |
| 11 | BFLT | 0 = No fault asserted. 1 = Single-ended fault on B detected by the RxB receiver. |
| 10 | BDFLT | 0 = No fault asserted. 1 = Differential fault detected on RxB. |
| 9 | $\overline{\text{ZFLT}}$ | 0 = No fault asserted. 1 = Single-ended fault on $\overline{\text{Z}}$ detected by the RxZ receiver. |
| 8 | ZFLT | 0 = No fault asserted. 1 = Single-ended fault on Z detected by the RxZ receiver. |
| 7 | ZDFLT | 0 = No fault asserted. 1 = Differential fault detected on RxZ. |
| 6 | $\overline{\text{YFLT}}$ | 0 = No fault asserted. 1 = Single-ended fault on $\overline{\text{Y}}$ detected by the RxY receiver. |
| 5 | DIYFLT | 0 = No fault asserted. 1 = Single-ended fault on DIY detected by the RxY receiver. |
| 4 | YDFLT | 0 = No fault asserted. 1 = Differential fault detected on RxY. |
| 3 | D2LFLT | 0 = No fault asserted. 1 = Single-ended low-voltage fault on DI2 detected by the RxD2 receiver. |
| 2 | D2HFLT | 0 = No fault asserted. 1 = Single-ended high-voltage fault on DI2 detected by the RxD2 receiver. Only in TTL mode. |
| 1 | D3LFLT | 0 = No fault asserted. 1 = Single-ended low-voltage fault on DI3 detected by the RxD3 receiver. |
| 0 | D3HFLT | 0 = No fault asserted. 1 = Single-ended high-voltage fault on DI3 detected by the RxD3 receiver. Only in TTL mode. |

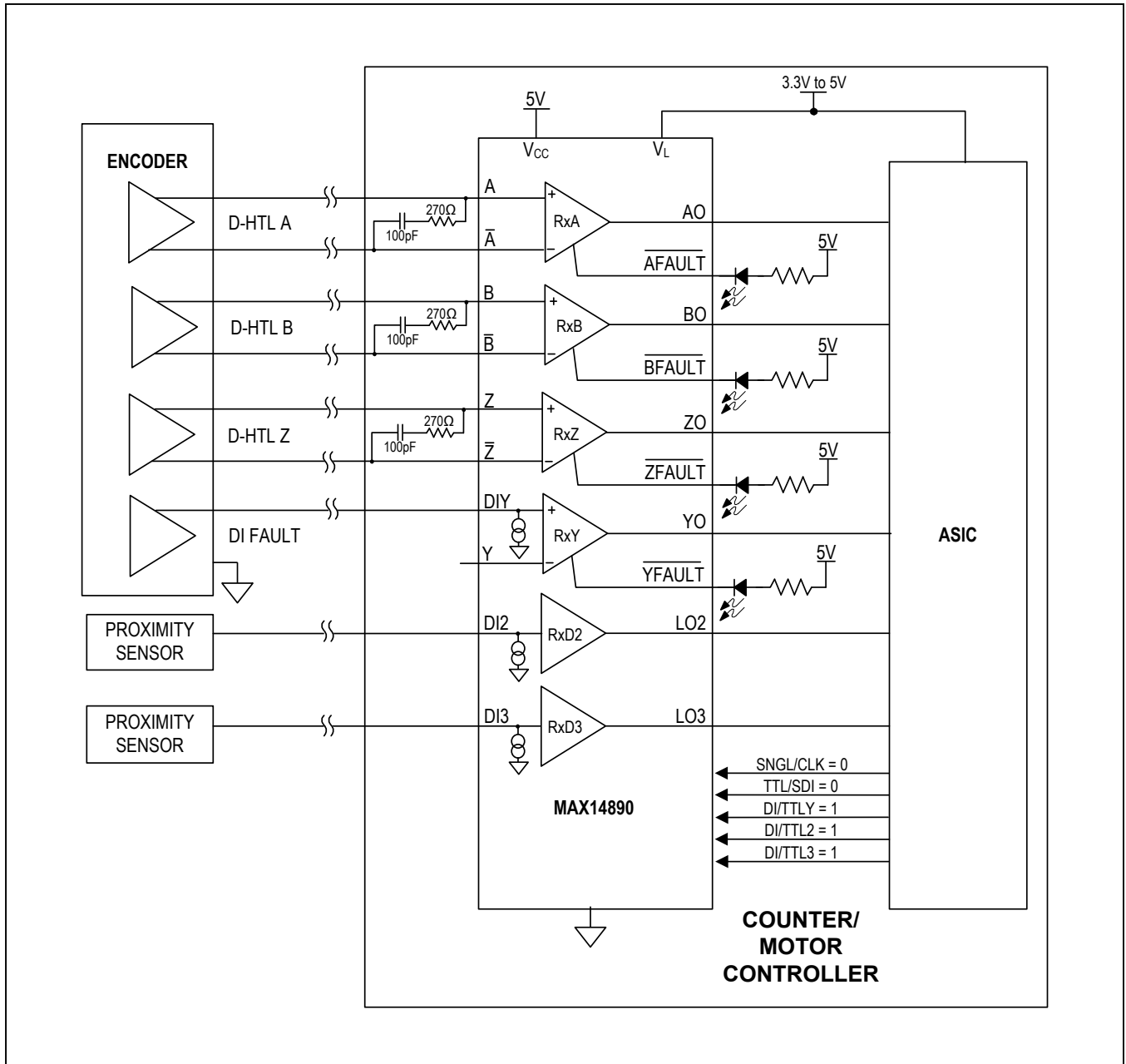

Figure 13. Encoder Circuit with Differential HTL (D-HTL) Signals and DI Alarm Signal

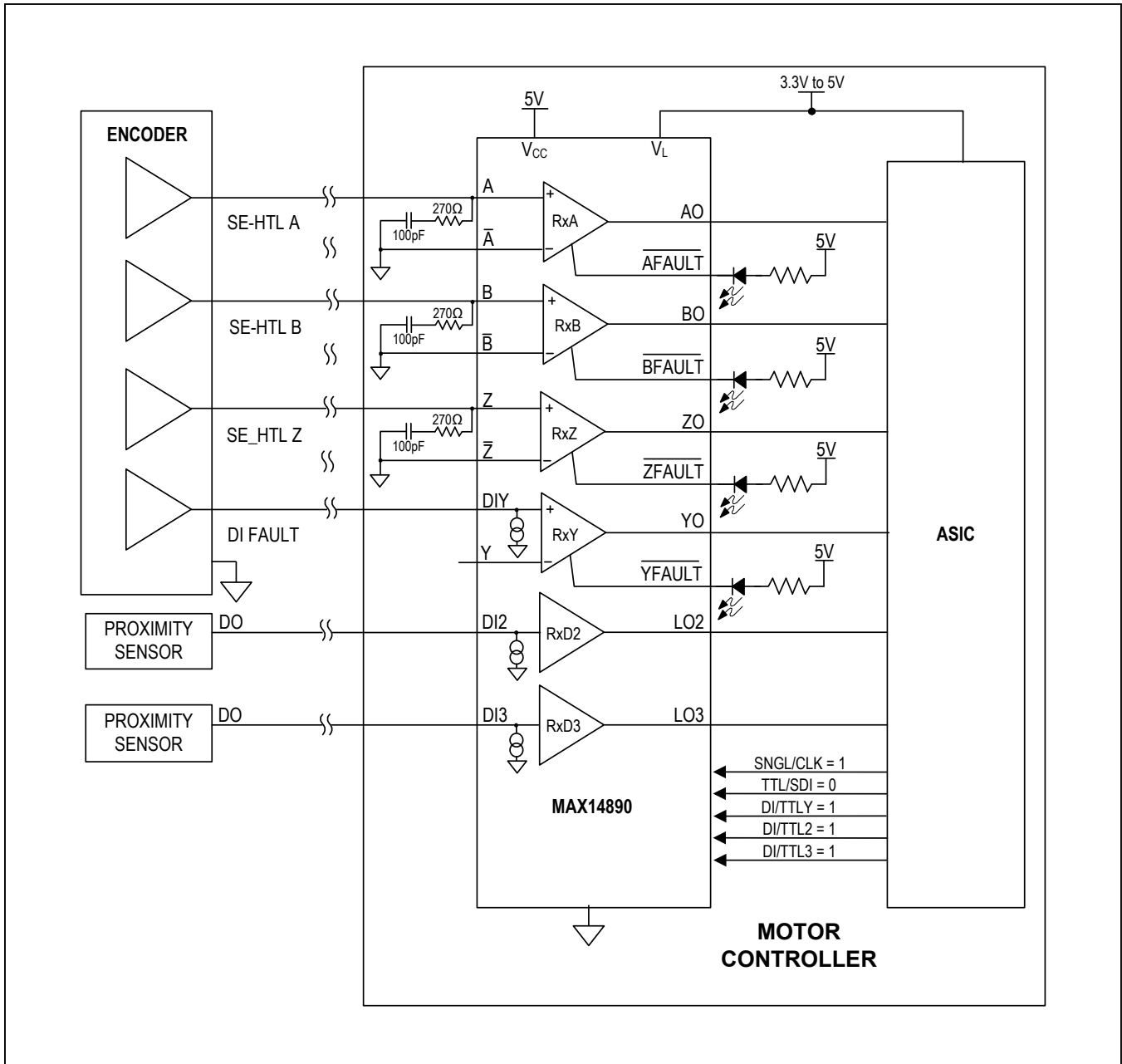

Figure 14. Encoder Circuit with Single-Ended HTL (SE-HTL) Signals and DI Alarm Signal

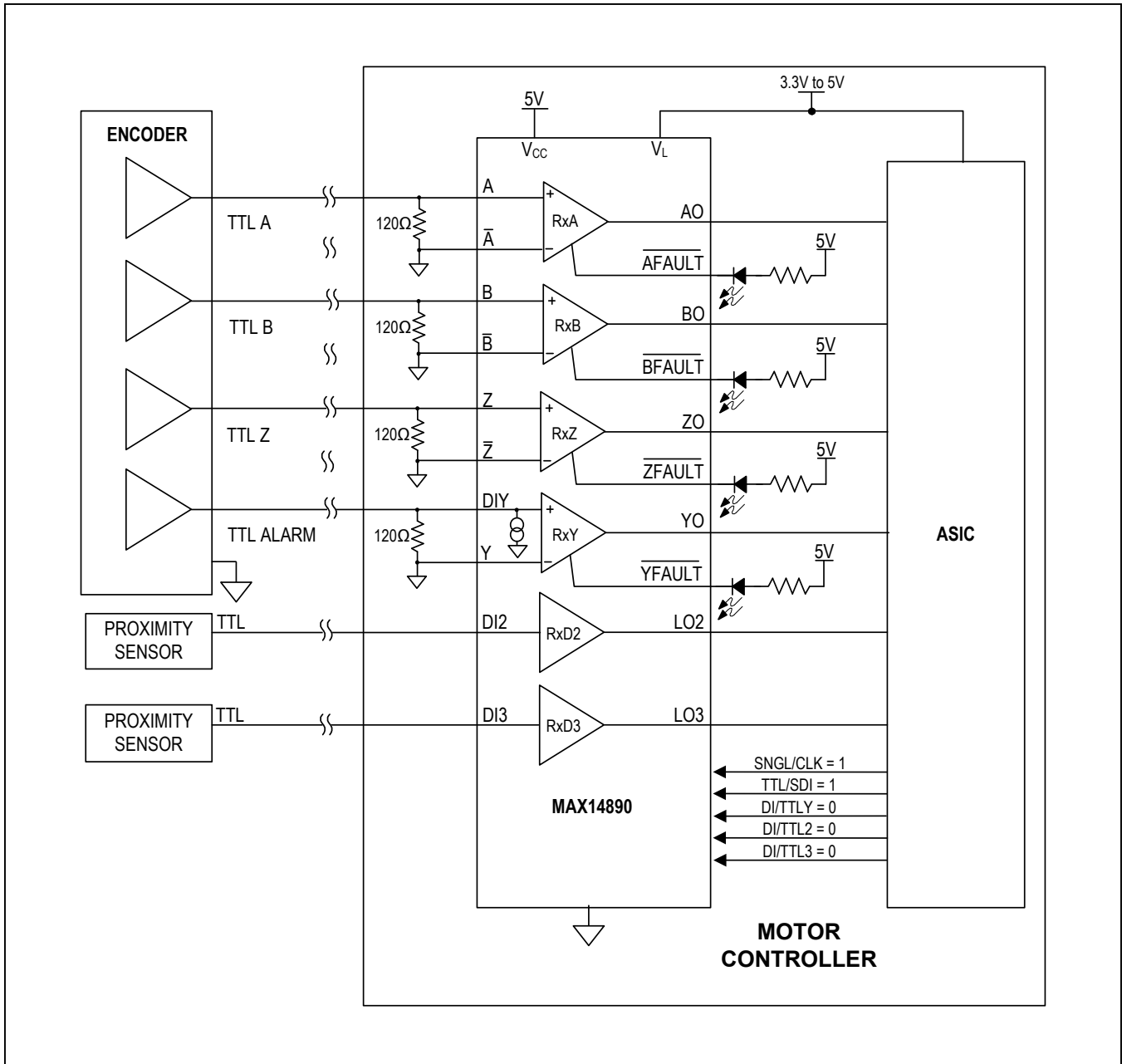
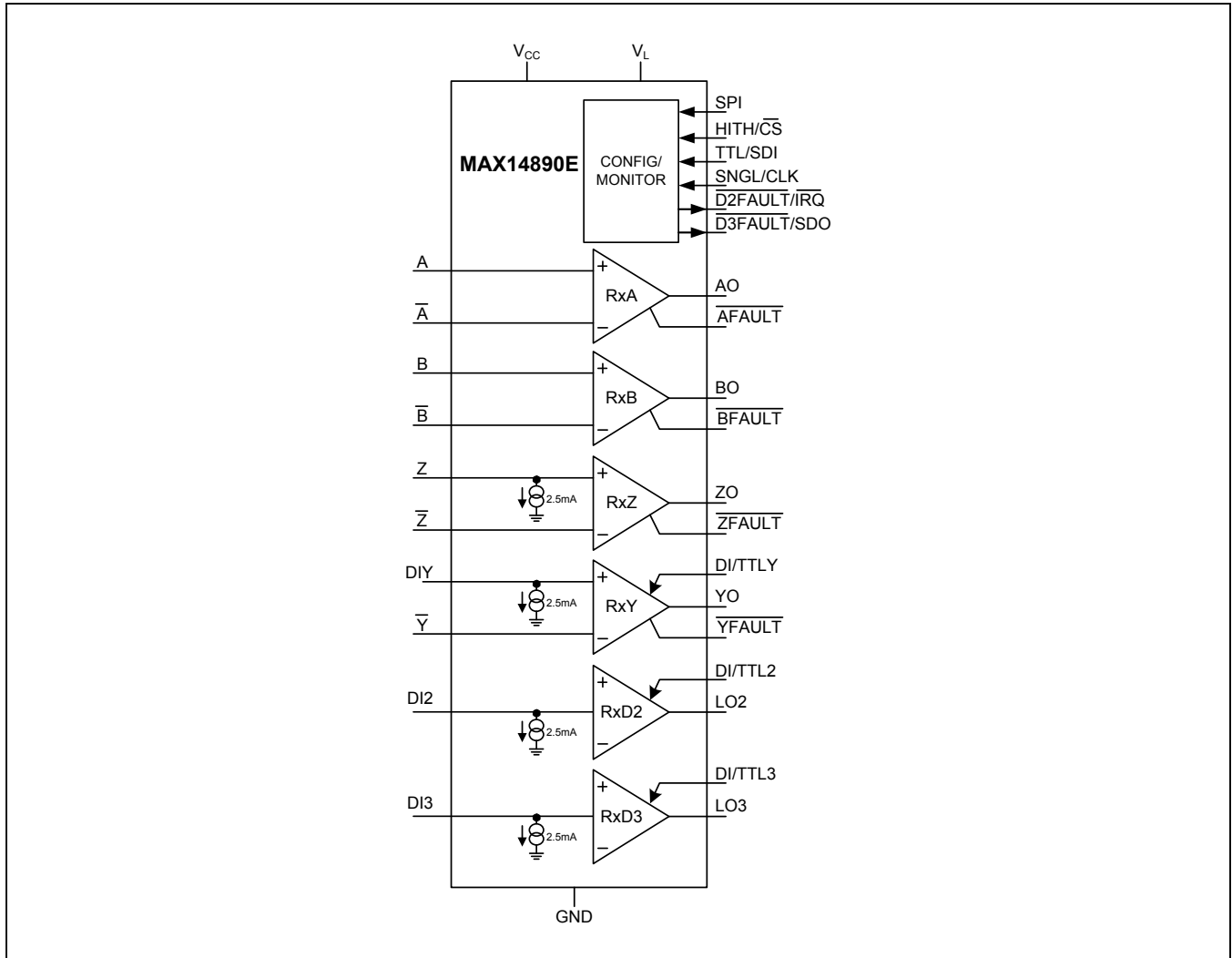

Figure 15. Encoder Circuit with TTL Signals and DI Alarm Signal

Functional Diagram



Ordering Information

| PART | TEMP RANGE | PIN PACKAGE |
|----------------|-----------------|-------------|
| MAX14890EATJ+ | -40°C to +125°C | 32 TQFN-EP |
| MAX14890EATJ+T | -40°C to +125°C | 32 TQFN-EP |

+Denotes a lead(Pb)-free/RoHS-compliant package.

T = Tape and reel.

*EP = Exposed pad.

Chip Information

PROCESS: BiCMOS

Package Information

For the latest package outline information and land patterns (footprints), go to www.maximintegrated.com/packages. Note that a "+", "#", or "-" in the package code indicates RoHS status only. Package drawings may show a different suffix character, but the drawing pertains to the package regardless of RoHS status.

| PACKAGE TYPE | PACKAGE CODE | OUTLINE NO. | LAND PATTERN NO. |
|--------------|--------------|-------------------------|-------------------------|
| 32 TQFN-EP | T3255+6 | 21-0140 | 90-0603 |

Revision History

| REVISION NUMBER | REVISION DATE | DESCRIPTION | PAGES CHANGED |
|-----------------|---------------|-----------------|---------------|
| 0 | 3/15 | Initial release | — |

For pricing, delivery, and ordering information, please contact Maxim Direct at 1-888-629-4642, or visit Maxim Integrated's website at www.maximintegrated.com.

Maxim Integrated cannot assume responsibility for use of any circuitry other than circuitry entirely embodied in a Maxim Integrated product. No circuit patent licenses are implied. Maxim Integrated reserves the right to change the circuitry and specifications without notice at any time. The parametric values (min and max limits) shown in the Electrical Characteristics table are guaranteed. Other parametric values quoted in this data sheet are provided for guidance.



Стандарт Электрон Связь

Мы молодая и активно развивающаяся компания в области поставок электронных компонентов. Мы поставляем электронные компоненты отечественного и импортного производства напрямую от производителей и с крупнейших складов мира.

Благодаря сотрудничеству с мировыми поставщиками мы осуществляем комплексные и плановые поставки широчайшего спектра электронных компонентов.

Собственная эффективная логистика и склад в обеспечивает надежную поставку продукции в точно указанные сроки по всей России.

Мы осуществляем техническую поддержку нашим клиентам и предпродажную проверку качества продукции. На все поставляемые продукты мы предоставляем гарантию .

Осуществляем поставки продукции под контролем ВП МО РФ на предприятия военно-промышленного комплекса России , а также работаем в рамках 275 ФЗ с открытием отдельных счетов в уполномоченном банке. Система менеджмента качества компании соответствует требованиям ГОСТ ISO 9001.

Минимальные сроки поставки, гибкие цены, неограниченный ассортимент и индивидуальный подход к клиентам являются основой для выстраивания долгосрочного и эффективного сотрудничества с предприятиями радиоэлектронной промышленности, предприятиями ВПК и научно-исследовательскими институтами России.

С нами вы становитесь еще успешнее!

Наши контакты:

Телефон: +7 812 627 14 35

Электронная почта: sales@st-electron.ru

Адрес: 198099, Санкт-Петербург,
Промышленная ул, дом № 19, литера Н,
помещение 100-Н Офис 331