

NHD-7.0-800480EF-ATXL#-T

TFT (Thin-Film-Transistor) Color Liquid Crystal Display Module

NHD-	Newhaven Display
7.0-	7.0" Diagonal
800480-	800xRGBx480 Pixels
EF-	Model
A-	Built-in Driver / No Controller
T-	White LED Backlight
X-	TFT
L-	12:00 Optimal View, Wide Temperature
#-	RoHS Compliant
T-	Resistive Touch Panel

Newhaven Display International, Inc.

2661 Galvin Ct.

Elgin IL, 60124

Ph: 847-844-8795

Fax: 847-844-8796

www.newhavendisplay.com

nhtech@newhavendisplay.com

nhsales@newhavendisplay.com

Document Revision History

Revision	Date	Description	Changed by
0	8/29/2013	Initial Release	ML
1	8/12/2014	Touch Panel Characteristics updated	ML
2	4/1/2015	Mechanical drawing updated	AK

Functions and Features

- 800xRGBx480 resolution
- LED backlight
- 24-bit digital RGB interface
- 16.7M colors
- 4-wire resistive Touch Panel

Mechanical Drawing

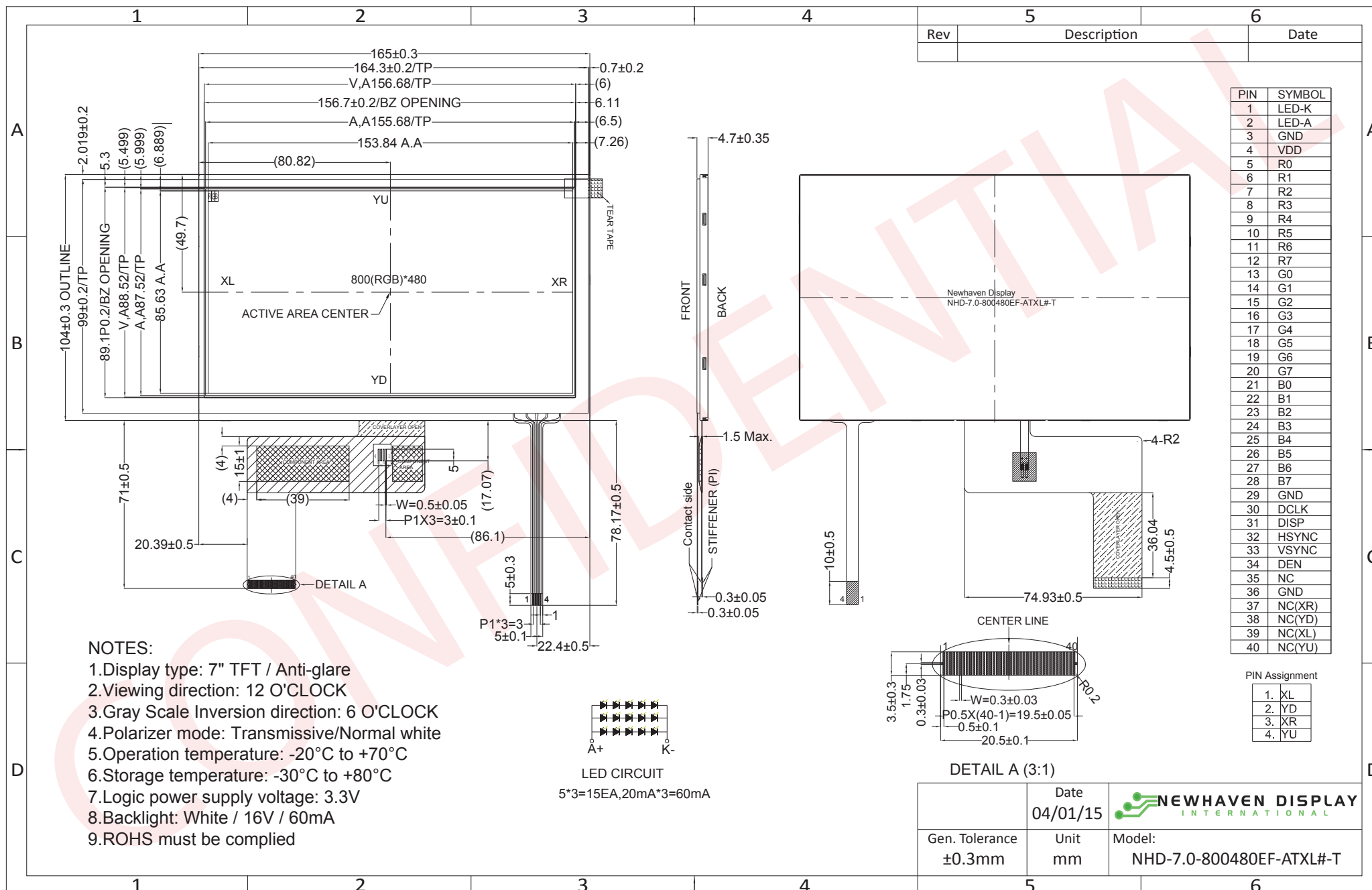

The drawing contained herein is the exclusive property of Newhaven Display International, Inc. and shall not be copied, reproduced, and/or disclosed in any format without permission.

Pin Description

TFT:

Pin No.	Symbol	Connection	Function Description
1	LED-K	Power Supply	Backlight Cathode
2	LED-A	Power Supply	Backlight Anode (60mA @ 16V)
3	GND	Power Supply	Ground
4	VDD	Power Supply	Supply Voltage for LCD (+3.3V)
5-12	[R0-R7]	MPU	Red Data signals
13-20	[G0-G7]	MPU	Green Data signals
21-28	[B0-B7]	MPU	Blue Data signals
29	GND	Power Supply	Ground
30	CLKIN	MPU	Clock for Input data
31	DISP	MPU	Display ON/OFF DISP=1:Display ON
32	HSD	MPU	Line Synchronization signal
33	VSD	MPU	Frame Synchronization signal
34	DEN	MPU	Data Enable signal
35	NC	-	No Connect
36	GND	Power Supply	Ground
37	NC(XR)	-	No Connect
38	NC(YD)	-	No Connect
39	NC(XL)	-	No Connect
40	NC(YU)	-	No Connect

Recommended connector: 0.5mm pitch 40-Conductor FFC. Molex p/n: 54104-4031 (top contact)

Touch Panel:

Pin No.	Symbol	Connection	Function Description
1	XL	Touch Panel	Touch Panel – LEFT
2	YD	Touch Panel	Touch Panel – DOWN
3	XR	Touch Panel	Touch Panel – RIGHT
4	YU	Touch Panel	Touch Panel – UP

Recommended connector: 1.0mm pitch 4-Conductor FFC. Molex p/n: 52207-0485 (top contact)

Driver/Controller Information

Built-in HX8264-D02 Source Driver: http://www.newhavendisplay.com/app_notes/HX8264-D02.pdf

Built-in HX8664-B Gate Driver: http://www.newhavendisplay.com/app_notes/HX8664-B.pdf

Electrical Characteristics

Item	Symbol	Condition	Min.	Typ.	Max.	Unit
Operating Temperature Range	Top	Absolute Max	-20	-	+70	°C
Storage Temperature Range	Tst	Absolute Max	-30	-	+80	°C
Supply Voltage	VDD	-	3.0	3.3	3.6	V
Supply Current	IDD	VDD=3.3V, 25°C	60	85	120	mA
"H" Level Input	VIH	-	0.7*VDD	-	VDD	V
"L" Level Input	VIL	-	GND	-	0.3*VDD	V
"H" Level Output	VOH	-	VDD-0.4	-	-	V
"L" Level Output	VOL	-	-	-	GND+0.4	V
Backlight Supply Voltage	VLED	-	14.5	16	16.5	V
Backlight Supply Current	ILED	VLED=16V	45	60	75	mA

Optical Characteristics

Item	Symbol	Condition	Min.	Typ.	Max.	Unit
Viewing Angle – Top	-	Cr ≥ 10	-	55	-	°
Viewing Angle – Bottom	-		-	65	-	°
Viewing Angle – Left	-		-	70	-	°
Viewing Angle – Right	-		-	70	-	°
Contrast Ratio	Cr	-	-	400	-	-
Luminance	L	-	170	220	-	cd/m ²
Response Time	Tr+Tf	-	-	25	35	ms

Viewing angles based on 6:00 gray scale inversion

Touch Panel Characteristics

Item	Min.	Typ.	Max.	Unit
Linearity	-3	-	3	%
Terminal Resistance – X-Axis	50	-	400	Ω
Terminal Resistance – Y-Axis	350	-	1100	Ω
Insulation Resistance	20	-	-	MΩ
Operating Voltage	-	-	10	V
Chattering	-	-	10	ms
Activation Force	10	-	100	g
Pen Writing Durability	20,000	-	-	Characters
Pitting Durability	1,000,000	-	-	Touches
Surface Hardness	3	-	-	H

Timing Characteristics

Parameter	Symbol	Spec.			Unit
		Min.	Typ.	Max.	
HS setup time	T_{hst}	8	-	-	ns
HS hold time	T_{hhd}	8	-	-	ns
VS setup time	T_{vst}	8	-	-	ns
VS hold time	T_{vhd}	8	-	-	ns
Data setup time	T_{dsu}	8	-	-	ns
Data hold time	T_{dhd}	8	-	-	ns
DE setup time	T_{esu}	8	-	-	ns
DE hold time	T_{ehd}	8	-	-	ns
VDD Power On Slew rate	T_{POR}	-	-	20	ms
RSTB pulse width	T_{Rst}	10	-	-	us
CLKIN cycle time	T_{cph}	20	-	-	ns
CLKIN pulse duty	T_{cwh}	40	50	60	%
Output stable time	T_{sst}	-	-	6	us

Horizontal Timing

Parameter	Symbol	Spec.			Unit
		Min.	Typ.	Max.	
Horizontal Display Area	thd	800			DCLK
DCLK frequency	fclk	-	30	50	MHz
One Horizontal Line	th	889	928	1143	DCLK
HS pulse width	thpw	1	48	255	DCLK
HS Back Porch (Blanking)	thb	88			DCLK
HS Front Porch	thfp	1	40	255	DCLK
DE mode Blanking	th-thd	85	128	512	DCLK

Vertical Timing

Parameter	Symbol	Spec.			Unit
		Min.	Typ.	Max.	
Vertical Display Area	tvd	480			T_H
VS period time	tv	513	525	767	T_H
VS pulse width	tvpw	3	3	255	T_H
VS Back Porch (Blanking)	tvb	32			T_H
VS Front Porch	tvfp	1	13	255	T_H
DE mode Blanking	tv-tvd	4	45	255	T_H

Horizontal Timing

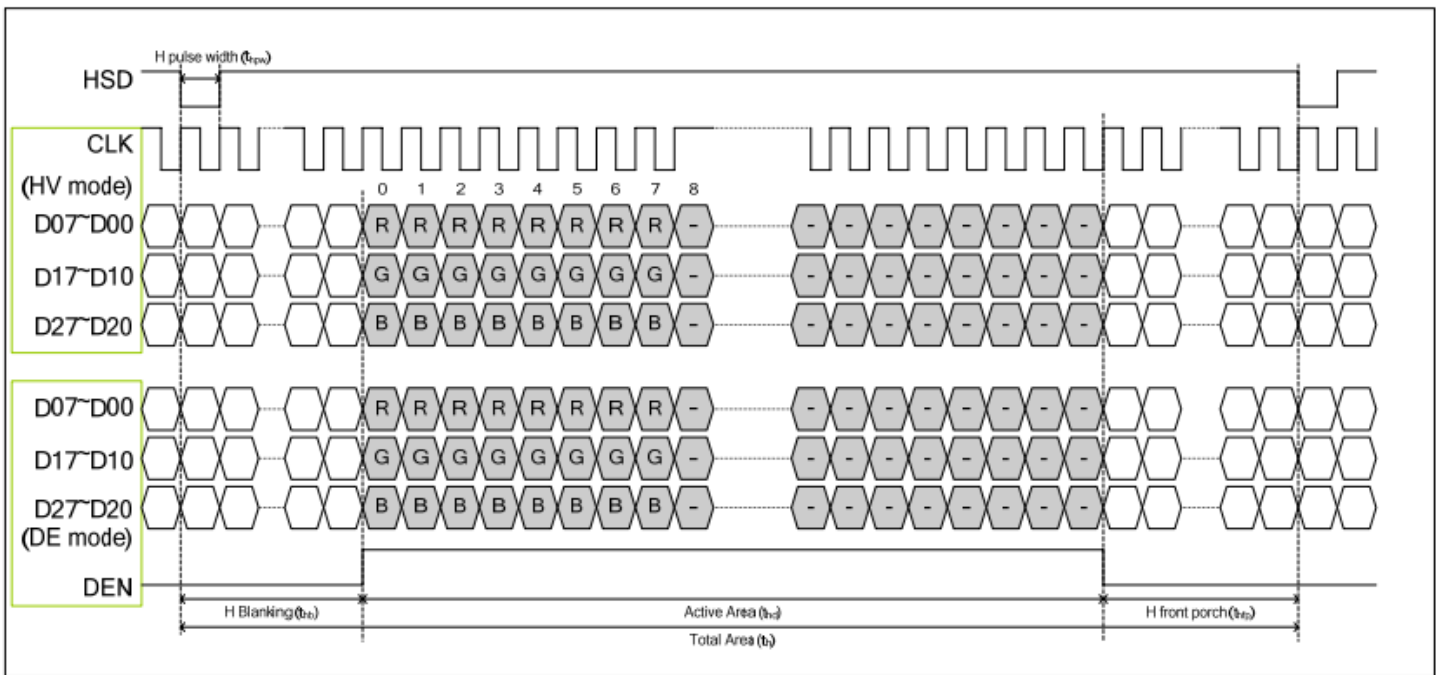

Vertical Timing

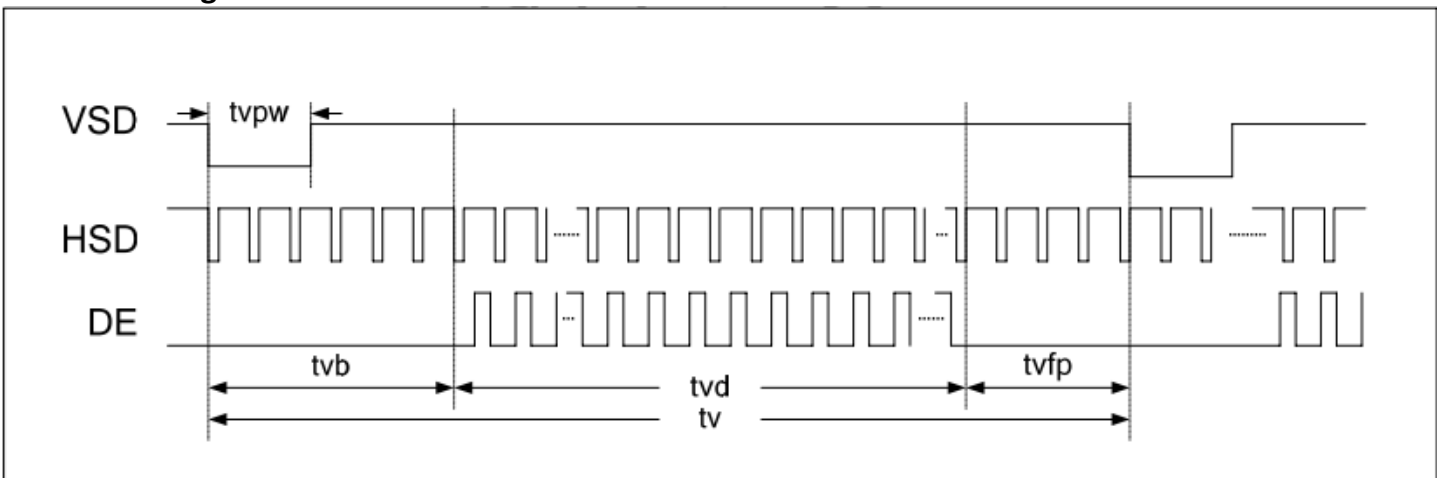

Parallel 24-bit RGB mode

Parameter	Symbol	Min.	Typ.	Max.	Unit	Conditions
CLKIN Frequency	Fclk	-	40	50	MHz	VDD=3.0V~3.6V
CLKIN Cycle Time	Tclk	20	25	-	ns	-
CLKIN Pulse Duty	Tcwh	40	50	60	%	Tclk
Time from HSD to Source Output	Thso		64		CLKIN	-
Time from HSD to LD	Thld		64		CLKIN	-
Time from HSD to STV	Thstv		2		CLKIN	-
Time from HSD to CKV	Thckv		20		CLKIN	-
Time from HSD to OEV	Thoev		4		CLKIN	-
LD Pulse Width	Twld		10		CLKIN	-
CKV Pulse Width	Twckv		66		CLKIN	-
OEV Pulse Width	Twoev		74		CLKIN	-

Input Clock and Data Timing

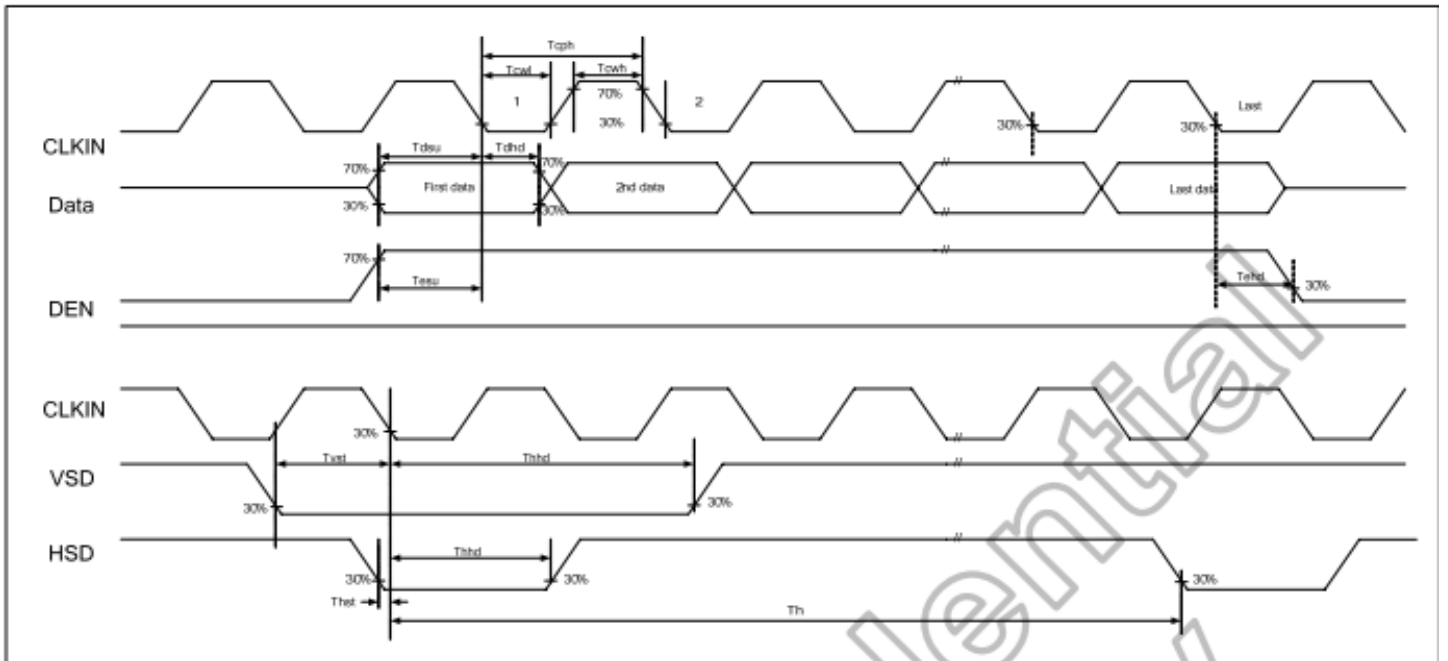

Source Output Timing

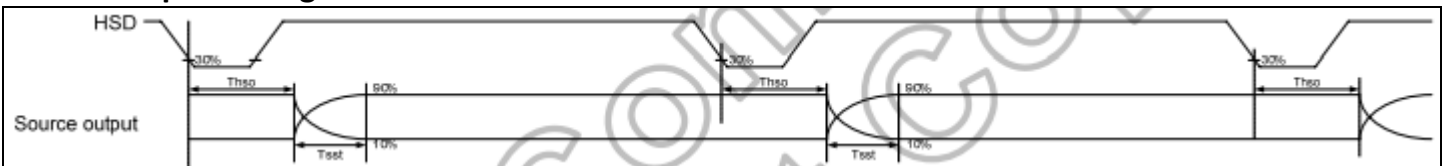

Vertical Timing HV (Cascade)

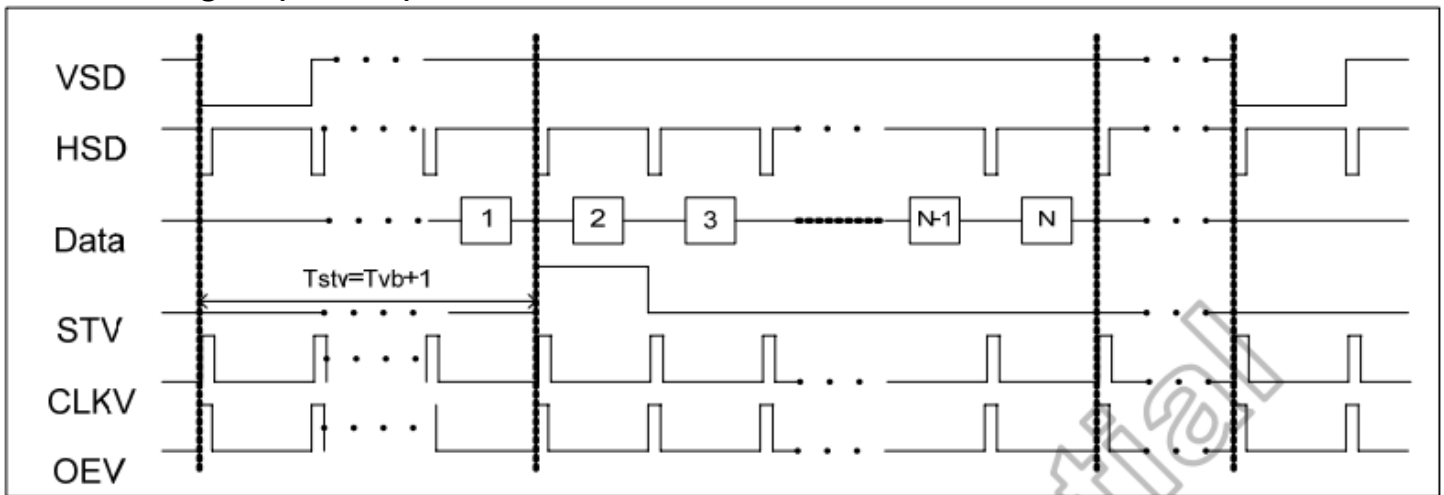

Vertical Timing DE (Cascade)

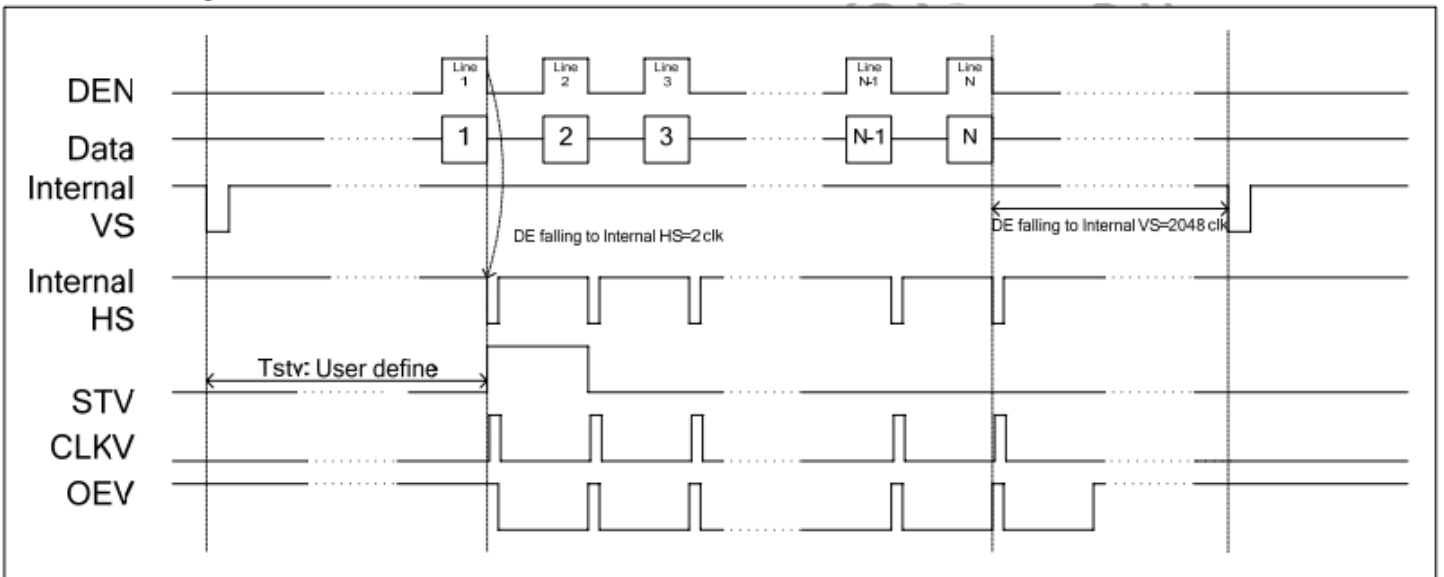

Gate Output Timing (Cascade)

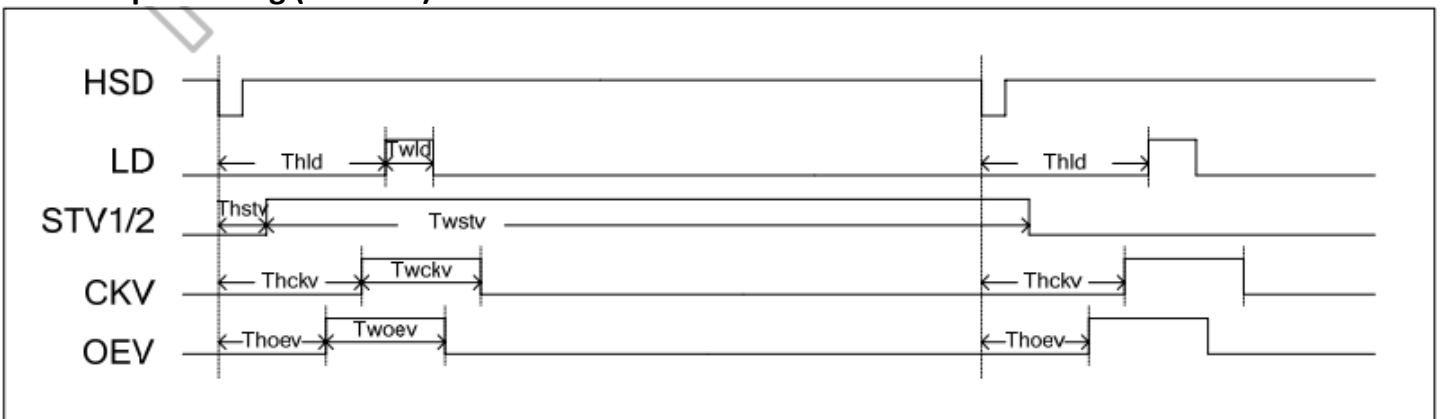

Vertical Timing HV (Dual Gate)

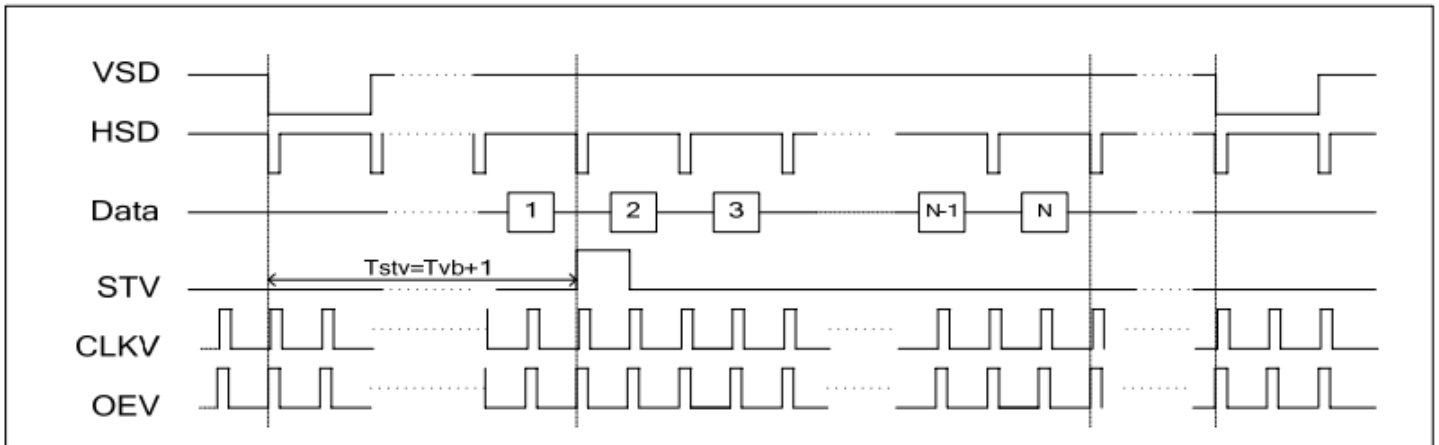

Vertical Timing DE (Dual Gate)

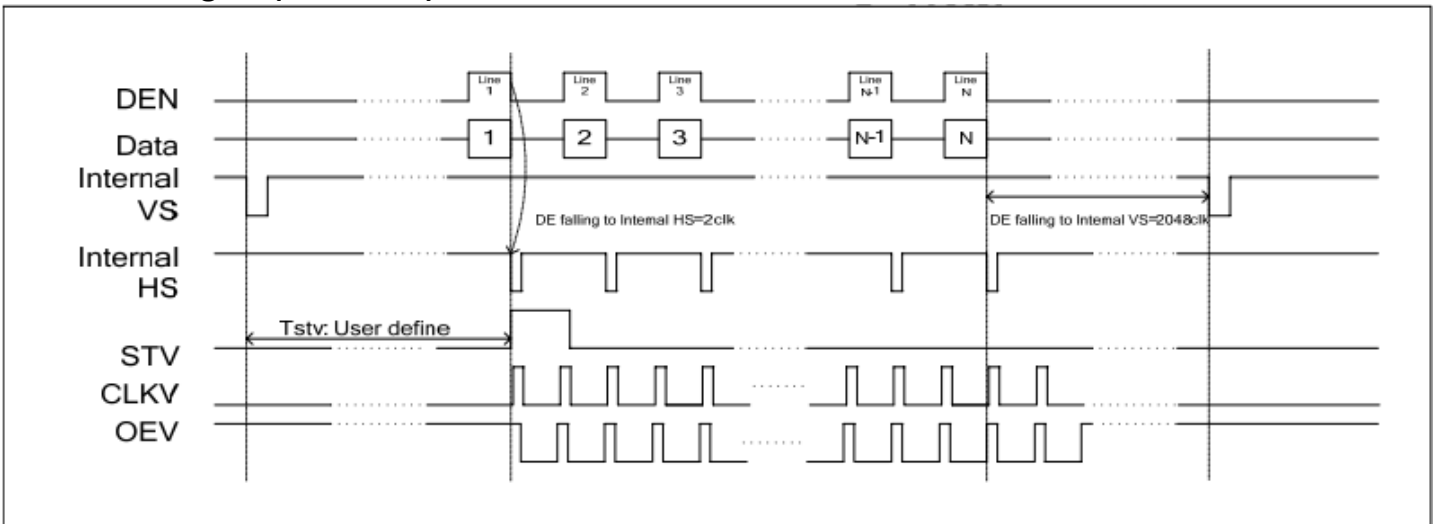

Gate Output Timing (Dual Gate)

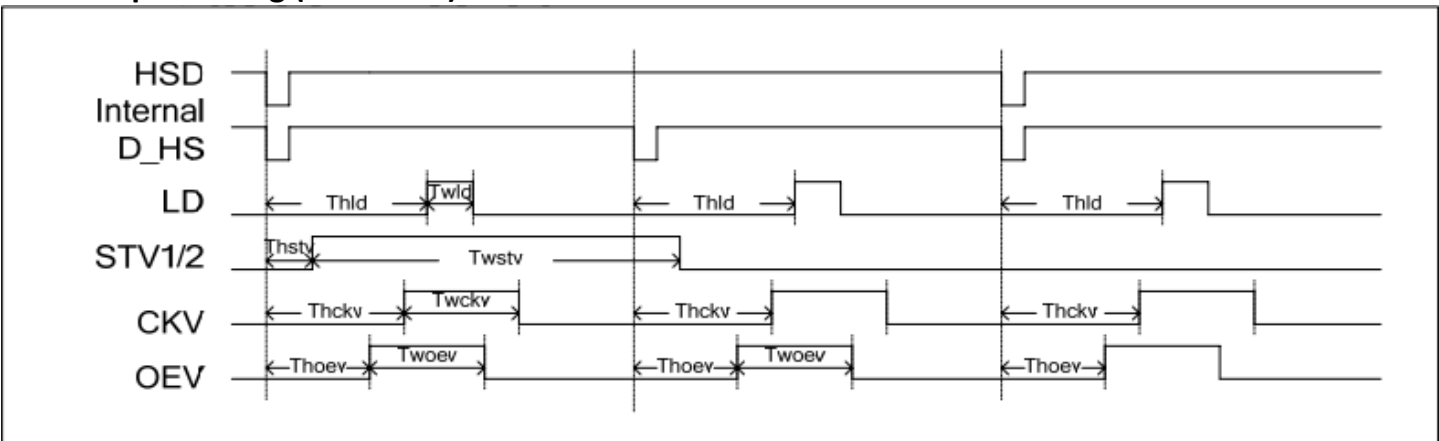

Power ON/OFF Sequence

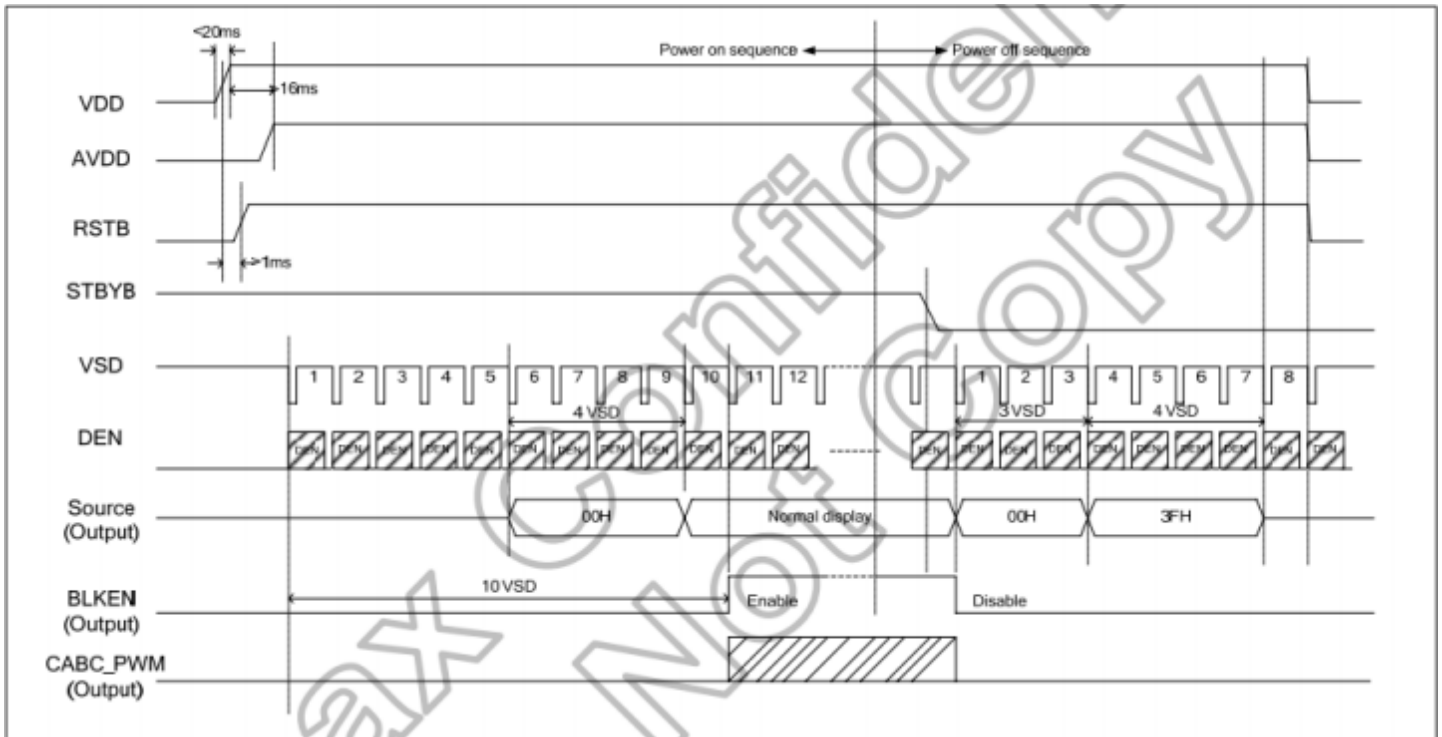

Enter/Exit Standby Mode Sequence

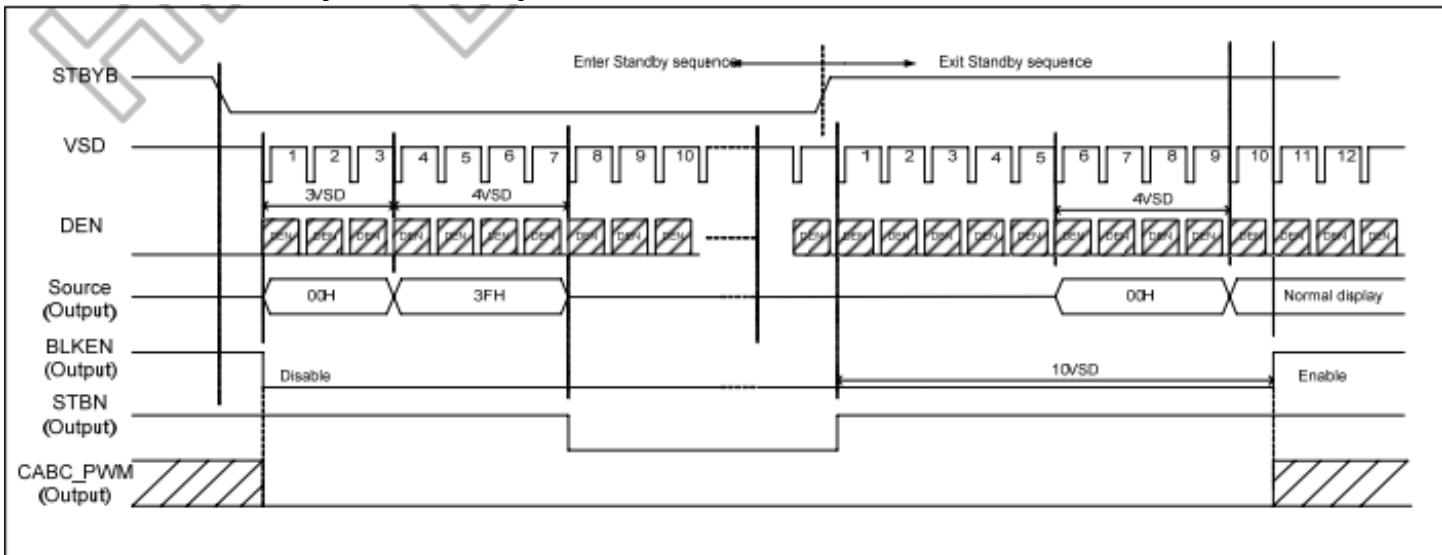

Quality Information

Test Item	Content of Test	Test Condition	Note
High Temperature storage	Endurance test applying the high storage temperature for a long time.	+80°C , 96hrs	2
Low Temperature storage	Endurance test applying the low storage temperature for a long time.	-30°C , 96hrs	1,2
High Temperature Operation	Endurance test applying the electric stress (voltage & current) and the high thermal stress for a long time.	+70°C, 96hrs	2
Low Temperature Operation	Endurance test applying the electric stress (voltage & current) and the low thermal stress for a long time.	-20°C , 96hrs	1,2
High Temperature / Humidity Operation	Endurance test applying the electric stress (voltage & current) and the high thermal with high humidity stress for a long time.	+50°C , 90% RH , 96hrs	1,2
Thermal Shock resistance	Endurance test applying the electric stress (voltage & current) during a cycle of low and high thermal stress.	-30°C, 30min -> 80°C, 30min, Change time: 5min, 10 cycles	
Vibration test	Endurance test applying vibration to simulate transportation and use.	10-55Hz , 1.5mm amplitude. 60 sec in each of 3 directions X,Y,Z For 15 minutes	3
Static electricity test	Endurance test applying electric static discharge.	VS=800V, RS=1.5kΩ, CS=100pF One time	

Note 1: No condensation to be observed.

Note 2: Conducted after 4 hours of storage at 25°C, 0%RH.

Note 3: Test performed on product itself, not inside a container.

Precautions for using LCDs/LCMs

See Precautions at www.newhavendisplay.com/specs/precautions.pdf

Warranty Information and Terms & Conditions

http://www.newhavendisplay.com/index.php?main_page=terms



Стандарт Электрон Связь

Мы молодая и активно развивающаяся компания в области поставок электронных компонентов. Мы поставляем электронные компоненты отечественного и импортного производства напрямую от производителей и с крупнейших складов мира.

Благодаря сотрудничеству с мировыми поставщиками мы осуществляем комплексные и плановые поставки широчайшего спектра электронных компонентов.

Собственная эффективная логистика и склад в обеспечивает надежную поставку продукции в точно указанные сроки по всей России.

Мы осуществляем техническую поддержку нашим клиентам и предпродажную проверку качества продукции. На все поставляемые продукты мы предоставляем гарантию .

Осуществляем поставки продукции под контролем ВП МО РФ на предприятия военно-промышленного комплекса России , а также работаем в рамках 275 ФЗ с открытием отдельных счетов в уполномоченном банке. Система менеджмента качества компании соответствует требованиям ГОСТ ISO 9001.

Минимальные сроки поставки, гибкие цены, неограниченный ассортимент и индивидуальный подход к клиентам являются основой для выстраивания долгосрочного и эффективного сотрудничества с предприятиями радиоэлектронной промышленности, предприятиями ВПК и научно-исследовательскими институтами России.

С нами вы становитесь еще успешнее!

Наши контакты:

Телефон: +7 812 627 14 35

Электронная почта: sales@st-electron.ru

Адрес: 198099, Санкт-Петербург,
Промышленная ул, дом № 19, литера Н,
помещение 100-Н Офис 331