

# ESP32-WROOM-32 Datasheet

Version 2.5



**Espressif Systems**

# About This Document

This document provides the specifications for the ESP32-WROOM-32 module.

## Revision History

For revision history of this document, please refer to the [last page](#).

## Documentation Change Notification

Espressif provides email notifications to keep customers updated on changes to technical documentation. Please subscribe [here](#).

## Certification

Download certificates for Espressif products from [here](#).

## Disclaimer and Copyright Notice

Information in this document, including URL references, is subject to change without notice. THIS DOCUMENT IS PROVIDED AS IS WITH NO WARRANTIES WHATSOEVER, INCLUDING ANY WARRANTY OF MERCHANTABILITY, NON-INFRINGEMENT, FITNESS FOR ANY PARTICULAR PURPOSE, OR ANY WARRANTY OTHERWISE ARISING OUT OF ANY PROPOSAL, SPECIFICATION OR SAMPLE.

All liability, including liability for infringement of any proprietary rights, relating to use of information in this document is disclaimed. No licenses express or implied, by estoppel or otherwise, to any intellectual property rights are granted herein. The Wi-Fi Alliance Member logo is a trademark of the Wi-Fi Alliance. The Bluetooth logo is a registered trademark of Bluetooth SIG.

All trade names, trademarks and registered trademarks mentioned in this document are property of their respective owners, and are hereby acknowledged.

Copyright © 2018 Espressif Inc. All rights reserved.

# Contents

<b>1 Overview</b>	1
<b>2 Pin Definitions</b>	3
2.1 Pin Layout	3
2.2 Pin Description	3
2.3 Strapping Pins	4
<b>3 Functional Description</b>	6
3.1 CPU and Internal Memory	6
3.2 External Flash and SRAM	6
3.3 Crystal Oscillators	6
3.4 RTC and Low-Power Management	7
<b>4 Peripherals and Sensors</b>	8
<b>5 Electrical Characteristics</b>	9
5.1 Absolute Maximum Ratings	9
5.2 Recommended Operating Conditions	9
5.3 DC Characteristics (3.3V, 25°C)	9
5.4 Wi-Fi Radio	10
5.5 BLE Radio	10
5.5.1 Receiver	10
5.5.2 Transmitter	11
5.6 Reflow Profile	12
<b>6 Schematics</b>	13
<b>7 Peripheral Schematics</b>	14
<b>8 Physical Dimensions</b>	16
<b>9 Recommended PCB Land Pattern</b>	17
<b>10 Learning Resources</b>	18
10.1 Must-Read Documents	18
10.2 Must-Have Resources	18
<b>Revision History</b>	19

## List of Tables

1	ESP32-WROOM-32 Specifications	1
2	Pin Definitions	3
3	Strapping Pins	5
4	Power Consumption by Power Modes	7
5	Absolute Maximum Ratings	9
6	Recommended Operating Conditions	9
7	DC Characteristics	9
8	Wi-Fi Radio Characteristics	10
9	Receiver Characteristics – BLE	10
10	Transmitter Characteristics – BLE	11

## List of Figures

1	ESP32-WROOM-32 Pin layout	3
2	Reflow Profile	12
3	ESP32-WROOM-32 Schematics	13
4	ESP32-WROOM-32 Peripheral Schematics	14
5	Discharge Circuit for VDD33 Rail	14
6	Reset Circuit	15
7	Physical Dimensions of ESP32-WROOM-32	16
8	Recommended PCB Land Pattern	17

# 1. Overview

ESP32-WROOM-32 is a powerful, generic Wi-Fi+BT+BLE MCU module that targets a wide variety of applications, ranging from low-power sensor networks to the most demanding tasks, such as voice encoding, music streaming and MP3 decoding.

At the core of this module is the ESP32-D0WDQ6 chip\*. The chip embedded is designed to be scalable and adaptive. There are two CPU cores that can be individually controlled, and the CPU clock frequency is adjustable from 80 MHz to 240 MHz. The user may also power off the CPU and make use of the low-power co-processor to constantly monitor the peripherals for changes or crossing of thresholds. ESP32 integrates a rich set of peripherals, ranging from capacitive touch sensors, Hall sensors, SD card interface, Ethernet, high-speed SPI, UART, I2S and I2C.

**Note:**

\* For details on the part number of the ESP32 series, please refer to the document [ESP32 Datasheet](#).

The integration of Bluetooth, Bluetooth LE and Wi-Fi ensures that a wide range of applications can be targeted, and that the module is future proof: using Wi-Fi allows a large physical range and direct connection to the internet through a Wi-Fi router, while using Bluetooth allows the user to conveniently connect to the phone or broadcast low energy beacons for its detection. The sleep current of the ESP32 chip is less than 5  $\mu$ A, making it suitable for battery powered and wearable electronics applications. ESP32 supports a data rate of up to 150 Mbps, and 20.5 dBm output power at the antenna to ensure the widest physical range. As such the chip does offer industry-leading specifications and the best performance for electronic integration, range, power consumption, and connectivity.

The operating system chosen for ESP32 is freeRTOS with LwIP; TLS 1.2 with hardware acceleration is built in as well. Secure (encrypted) over the air (OTA) upgrade is also supported, so that developers can continually upgrade their products even after their release.

Table 1 provides the specifications of ESP32-WROOM-32.

**Table 1: ESP32-WROOM-32 Specifications**

Categories	Items	Specifications
Certification	RF certification	FCC/CE/IC/TELEC/KCC/SRRC/NCC
	Wi-Fi certification	Wi-Fi Alliance
	Bluetooth certification	BQB
	Green certification	RoHS/REACH
Wi-Fi	Protocols	802.11 b/g/n (802.11n up to 150 Mbps) A-MPDU and A-MSDU aggregation and 0.4 $\mu$ s guard interval support
	Frequency range	2.4 GHz ~ 2.5 GHz
Bluetooth	Protocols	Bluetooth v4.2 BR/EDR and BLE specification
	Radio	NZIF receiver with -97 dBm sensitivity
		Class-1, class-2 and class-3 transmitter
		AFH
Audio	CVSD and SBC	

Categories	Items	Specifications
Hardware	Module interface	SD card, UART, SPI, SDIO, I2C, LED PWM, Motor PWM, I2S, IR
		GPIO, capacitive touch sensor, ADC, DAC
	On-chip sensor	Hall sensor
	On-board clock	40 MHz crystal
	Operating voltage/Power supply	2.7 ~ 3.6V
	Operating current	Average: 80 mA
	Minimum current delivered by power supply	500 mA
	Recommended operating temperature range	-40°C ~ +85°C
	Package size	(18±0.2) mm x (25.5±0.2) mm x (3.1±0.15) mm
Software	Wi-Fi mode	Station/SoftAP/SoftAP+Station/P2P
	Wi-Fi Security	WPA/WPA2/WPA2-Enterprise/WPS
	Encryption	AES/RSA/ECC/SHA
	Firmware upgrade	UART Download / OTA (download and write firmware via network or host)
	Software development	Supports Cloud Server Development / SDK for custom firmware development
	Network protocols	IPv4, IPv6, SSL, TCP/UDP/HTTP/FTP/MQTT
	User configuration	AT instruction set, cloud server, Android/iOS app

## 2. Pin Definitions

### 2.1 Pin Layout

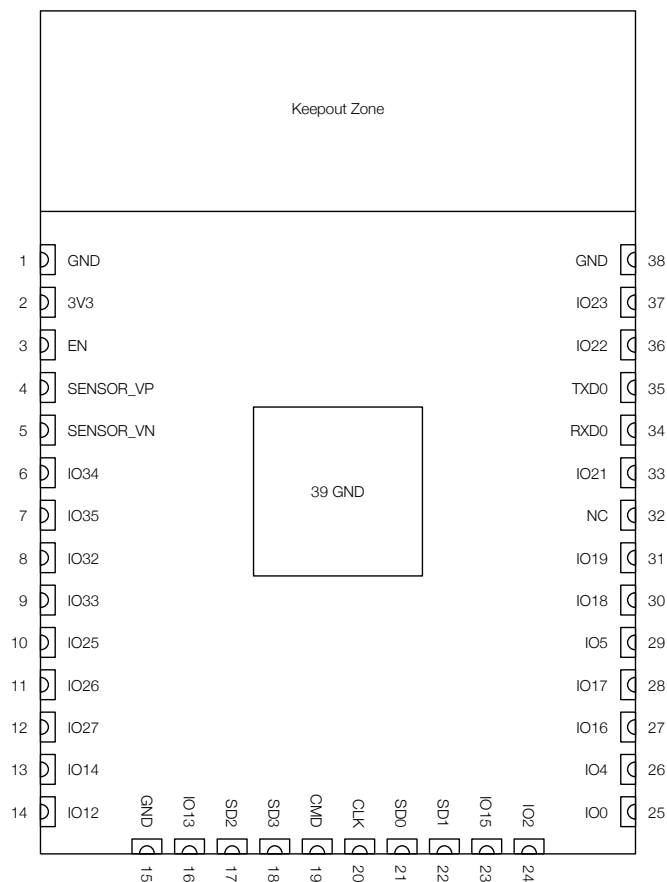

Figure 1: ESP32-WROOM-32 Pin layout

### 2.2 Pin Description

ESP32-WROOM-32 has 38 pins. See pin definitions in Table 2.

Table 2: Pin Definitions

Name	No.	Type	Function
GND	1	P	Ground
3V3	2	P	Power supply
EN	3	I	Module-enable signal. Active high.
SENSOR_VP	4	I	GPIO36, ADC1_CH0, RTC_GPIO0
SENSOR_VN	5	I	GPIO39, ADC1_CH3, RTC_GPIO3
IO34	6	I	GPIO34, ADC1_CH6, RTC_GPIO4
IO35	7	I	GPIO35, ADC1_CH7, RTC_GPIO5
IO32	8	I/O	GPIO32, XTAL_32K_P (32.768 kHz crystal oscillator input), ADC1_CH4, TOUCH9, RTC_GPIO9
IO33	9	I/O	GPIO33, XTAL_32K_N (32.768 kHz crystal oscillator output), ADC1_CH5, TOUCH8, RTC_GPIO8



Name	No.	Type	Function
IO25	10	I/O	GPIO25, DAC_1, ADC2_CH8, RTC_GPIO6, EMAC_RXD0
IO26	11	I/O	GPIO26, DAC_2, ADC2_CH9, RTC_GPIO7, EMAC_RXD1
IO27	12	I/O	GPIO27, ADC2_CH7, TOUCH7, RTC_GPIO17, EMAC_RX_DV
IO14	13	I/O	GPIO14, ADC2_CH6, TOUCH6, RTC_GPIO16, MTMS, HSPICLK, HS2_CLK, SD_CLK, EMAC_TXD2
IO12	14	I/O	GPIO12, ADC2_CH5, TOUCH5, RTC_GPIO15, MTDI, HSPIQ, HS2_DATA2, SD_DATA2, EMAC_TXD3
GND	15	P	Ground
IO13	16	I/O	GPIO13, ADC2_CH4, TOUCH4, RTC_GPIO14, MTCK, HSPID, HS2_DATA3, SD_DATA3, EMAC_RX_ER
SHD/SD2*	17	I/O	GPIO9, SD_DATA2, SPIHD, HS1_DATA2, U1RXD
SWP/SD3*	18	I/O	GPIO10, SD_DATA3, SPIWP, HS1_DATA3, U1TXD
SCS/CMD*	19	I/O	GPIO11, SD_CMD, SPICS0, HS1_CMD, U1RTS
SCK/CLK*	20	I/O	GPIO6, SD_CLK, SPICLK, HS1_CLK, U1CTS
SDO/SD0*	21	I/O	GPIO7, SD_DATA0, SPIQ, HS1_DATA0, U2RTS
SDI/SD1*	22	I/O	GPIO8, SD_DATA1, SPID, HS1_DATA1, U2CTS
IO15	23	I/O	GPIO15, ADC2_CH3, TOUCH3, MTDO, HSPICS0, RTC_GPIO13, HS2_CMD, SD_CMD, EMAC_RXD3
IO2	24	I/O	GPIO2, ADC2_CH2, TOUCH2, RTC_GPIO12, HSPIWP, HS2_DATA0, SD_DATA0
IO0	25	I/O	GPIO0, ADC2_CH1, TOUCH1, RTC_GPIO11, CLK_OUT1, EMAC_TX_CLK
IO4	26	I/O	GPIO4, ADC2_CH0, TOUCH0, RTC_GPIO10, HSPIHD, HS2_DATA1, SD_DATA1, EMAC_TX_ER
IO16	27	I/O	GPIO16, HS1_DATA4, U2RXD, EMAC_CLK_OUT
IO17	28	I/O	GPIO17, HS1_DATA5, U2TXD, EMAC_CLK_OUT_180
IO5	29	I/O	GPIO5, VSPICS0, HS1_DATA6, EMAC_RX_CLK
IO18	30	I/O	GPIO18, VSPICLK, HS1_DATA7
IO19	31	I/O	GPIO19, VSPIQ, U0CTS, EMAC_TXD0
NC	32	-	-
IO21	33	I/O	GPIO21, VSPIHD, EMAC_TX_EN
RXD0	34	I/O	GPIO3, U0RXD, CLK_OUT2
TXD0	35	I/O	GPIO1, U0TXD, CLK_OUT3, EMAC_RXD2
IO22	36	I/O	GPIO22, VSPIWP, U0RTS, EMAC_TXD1
IO23	37	I/O	GPIO23, VSPID, HS1_STROBE
GND	38	P	Ground

**Important:**

\* Pins SCK/CLK, SDO/SD0, SDI/SD1, SHD/SD2, SWP/SD3 and SCS/CMD, namely, GPIO6 to GPIO11 are connected to the integrated SPI flash integrated on the module and are not recommended for other uses.

## 2.3 Strapping Pins

ESP32 has five strapping pins, which can be seen in Chapter 6 Schematics:

- MTDI
- GPIO0
- GPIO2
- MTDO
- GPIO5

Software can read the values of these five bits from register "GPIO\_STRAPPING".

During the chip's system reset (power-on-reset, RTC watchdog reset and brownout reset), the latches of the strapping pins sample the voltage level as strapping bits of "0" or "1", and hold these bits until the chip is powered down or shut down. The strapping bits configure the device's boot mode, the operating voltage of VDD\_SDIO and other initial system settings.

Each strapping pin is connected to its internal pull-up/pull-down during the chip reset. Consequently, if a strapping pin is unconnected or the connected external circuit is high-impedance, the internal weak pull-up/pull-down will determine the default input level of the strapping pins.

To change the strapping bit values, users can apply the external pull-down/pull-up resistances, or use the host MCU's GPIOs to control the voltage level of these pins when powering on ESP32.

After reset, the strapping pins work as normal-function pins.

Refer to Table 3 for a detailed boot-mode configuration by strapping pins.

**Table 3: Strapping Pins**

Voltage of Internal LDO (VDD_SDIO)					
Pin	Default	3.3V		1.8V	
MTDI	Pull-down	0		1	
Bootling Mode					
Pin	Default	SPI Boot		Download Boot	
GPIO0	Pull-up	1		0	
GPIO2	Pull-down	Don't-care		0	
Enabling/Disabling Debugging Log Print over U0TXD During Bootling					
Pin	Default	U0TXD Toggling		U0TXD Silent	
MTDO	Pull-up	1		0	
Timing of SDIO Slave					
Pin	Default	Falling-edge Input Falling-edge Output	Falling-edge Input Rising-edge Output	Rising-edge Input Falling-edge Output	Rising-edge Input Rising-edge Output
MTDO	Pull-up	0	0	1	1
GPIO5	Pull-up	0	1	0	1

**Note:**

- Firmware can configure register bits to change the settings of "Voltage of Internal LDO (VDD\_SDIO)" and "Timing of SDIO Slave" after bootling.
- The module integrates a 3.3V SPI flash, so the pin MTDI cannot be set to 1 when the module is powered up.

## 3. Functional Description

This chapter describes the modules and functions integrated in ESP32-WROOM-32.

### 3.1 CPU and Internal Memory

ESP32-D0WDQ6 contains two low-power Xtensa® 32-bit LX6 microprocessors. The internal memory includes:

- 448 kB of ROM for booting and core functions.
- 520 kB of on-chip SRAM for data and instructions.
- 8 kB of SRAM in RTC, which is called RTC FAST Memory and can be used for data storage; it is accessed by the main CPU during RTC Boot from the Deep-sleep mode.
- 8 kB of SRAM in RTC, which is called RTC SLOW Memory and can be accessed by the co-processor during the Deep-sleep mode.
- 1 kbit of eFuse: 256 bits are used for the system (MAC address and chip configuration) and the remaining 768 bits are reserved for customer applications, including flash-encryption and chip-ID.

### 3.2 External Flash and SRAM

ESP32 supports multiple external QSPI flash and SRAM chips. More details can be found in Chapter SPI in the [ESP32 Technical Reference Manual](#). ESP32 also supports hardware encryption/decryption based on AES to protect developers' programs and data in flash.

ESP32 can access the external QSPI flash and SRAM through high-speed caches.

- Up to 16 MB of external flash can be mapped into CPU instruction memory space and read-only memory space simultaneously.
  - When external flash is mapped into CPU instruction memory space, up to 11 MB+248 KB can be mapped at a time. Note that if more than 3 MB+248 KB are mapped, cache performance will be reduced due to speculative reads by the CPU.
  - When external flash is mapped into read-only data memory space, up to 4 MB can be mapped at a time. 8-bit, 16-bit and 32-bit reads are supported.
- External SRAM can be mapped into CPU data memory space. SRAM up to 8 MB is supported and up to 4 MB can be mapped at a time. 8-bit, 16-bit and 32-bit reads and writes are supported.

ESP32-WROOM-32 integrates 4 MB of external SPI flash. The 4-MB SPI flash can be memory-mapped onto the CPU code space, supporting 8, 16 and 32-bit access. Code execution is supported. The integrated SPI flash is connected to GPIO6, GPIO7, GPIO8, GPIO9, GPIO10 and GPIO11. These six pins cannot be used as regular GPIOs.

### 3.3 Crystal Oscillators

The module uses a 40-MHz crystal oscillator.

### 3.4 RTC and Low-Power Management

With the use of advanced power-management technologies, ESP32 can switch between different power modes.

- Power modes
  - Active mode: The chip radio is powered on. The chip can receive, transmit, or listen.
  - Modem-sleep mode: The CPU is operational and the clock is configurable. The Wi-Fi/Bluetooth base-band and radio are disabled.
  - Light-sleep mode: The CPU is paused. The RTC memory and RTC peripherals, as well as the ULP co-processor are running. Any wake-up events (MAC, host, RTC timer, or external interrupts) will wake up the chip.
  - Deep-sleep mode: Only RTC memory and RTC peripherals are powered on. Wi-Fi and Bluetooth connection data are stored in the RTC memory. The ULP co-processor is functional.
  - Hibernation mode: The internal 8-MHz oscillator and ULP co-processor are disabled. The RTC recovery memory is powered down. Only one RTC timer on the slow clock and certain RTC GPIOs are active. The RTC timer or the RTC GPIOs can wake up the chip from the Hibernation mode.

The power consumption varies with different power modes and work statuses of functional modules. Please see Table 4 for details.

**Table 4: Power Consumption by Power Modes**

Power mode	Description	Power consumption
Active (RF working)	Wi-Fi Tx packet	Please refer to <a href="#">ESP32 Datasheet</a> .
	Wi-Fi / BT Tx packet	
	Wi-Fi / BT Rx and listening	
Modem-sleep	The CPU is powered on.	Max speed 240 MHz: 30 mA ~ 50 mA
		Normal speed 80 MHz: 20 mA ~ 25 mA
		Slow speed 2 MHz: 2 mA ~ 4 mA
Light-sleep	-	0.8 mA
Deep-sleep	The ULP co-processor is powered on.	150 $\mu$ A
	ULP sensor-monitored pattern	100 $\mu$ A @1% duty
	RTC timer + RTC memory	10 $\mu$ A
Hibernation	RTC timer only	5 $\mu$ A
Power off	CHIP_PU is set to low level, the chip is powered off	0.1 $\mu$ A

**Note:**

- When Wi-Fi is enabled, the chip switches between Active and Modem-sleep mode. Therefore, power consumption changes accordingly.
- In Modem-sleep mode, the CPU frequency changes automatically. The frequency depends on the CPU load and the peripherals used.
- During Deep-sleep, when the ULP co-processor is powered on, peripherals such as GPIO and I2C are able to operate.
- When the system works in the ULP sensor-monitored pattern, the ULP co-processor works with the ULP sensor periodically; ADC works with a duty cycle of 1%, so the power consumption is 100  $\mu$ A.

## 4. Peripherals and Sensors

Please refer to Section Peripherals and Sensors in [ESP32 Datasheet](#).

**Note:**

External connections can be made to any GPIO except for GPIOs in the range 6-11. These six GPIOs are connected to the module's integrated SPI flash. For details, please see Section 6 Schematics.

## 5. Electrical Characteristics

### 5.1 Absolute Maximum Ratings

Stresses beyond the absolute maximum ratings listed in the table below may cause permanent damage to the device. These are stress ratings only, and do not refer to the functional operation of the device.

**Table 5: Absolute Maximum Ratings**

Symbol	Parameter	Min	Max	Unit
VDD33	-	-0.3	3.6	V
T <sub>store</sub>	Storage temperature	-40	150	°C

### 5.2 Recommended Operating Conditions

**Table 6: Recommended Operating Conditions**

Symbol	Parameter	Min	Typical	Max	Unit
VDD33	-	2.7	3.3	3.6	V
I <sub>VDD</sub>	Current delivered by external power supply	0.5	-	-	A
T	Operating temperature	-40	-	85	°C

### 5.3 DC Characteristics (3.3V, 25°C)

**Table 7: DC Characteristics**

Symbol	Parameter	Min	Typ	Max	Unit
C <sub>IN</sub>	Pin capacitance	-	2	-	pF
V <sub>IH</sub>	High-level input voltage	0.75 × VDD <sup>1</sup>	-	VDD + 0.3	V
V <sub>IL</sub>	Low-level input voltage	-0.3	-	0.25 × VDD	V
I <sub>IH</sub>	High-level input current	-	-	50	nA
I <sub>IL</sub>	Low-level input current	-	-	50	nA
V <sub>OH</sub>	High-level output voltage	0.8 × VDD	-	-	V
V <sub>OL</sub>	Low-level output voltage	-	-	0.1 × VDD	V
I <sub>OH</sub>	High-level source current (VDD = 3.3V, V <sub>OH</sub> = 2.64V, PAD_DRIVER = 3)	-	40	-	mA
I <sub>OL</sub>	Low-level sink current (VDD = 3.3V, V <sub>OL</sub> = 0.495V, PAD_DRIVER = 3)	-	28	-	mA
R <sub>PU</sub>	Pull-up resistor	-	45	-	kΩ
R <sub>PD</sub>	Pull-down resistor	-	45	-	kΩ
V <sub>IL_nRST</sub>	Low-level input voltage of EN to reset the module	-	-	0.6	V

1. VDD is the I/O voltage for a particular power domain of pins. More details can be found in Appendix IO\_MUX of [ESP32 Datasheet](#).

## 5.4 Wi-Fi Radio

**Table 8: Wi-Fi Radio Characteristics**

Description	Min	Typical	Max	Unit
Input frequency	2412	-	2484	MHz
Output impedance*	-	*	-	$\Omega$
Tx power				
Output power of PA for 72.2 Mbps	13	14	15	dBm
Output power of PA for 11b mode	19.5	20	20.5	dBm
Sensitivity				
DSSS, 1 Mbps	-	-98	-	dBm
CCK, 11 Mbps	-	-91	-	dBm
OFDM, 6 Mbps	-	-93	-	dBm
OFDM, 54 Mbps	-	-75	-	dBm
HT20, MCS0	-	-93	-	dBm
HT20, MCS7	-	-73	-	dBm
HT40, MCS0	-	-90	-	dBm
HT40, MCS7	-	-70	-	dBm
MCS32	-	-89	-	dBm
Adjacent channel rejection				
OFDM, 6 Mbps	-	37	-	dB
OFDM, 54 Mbps	-	21	-	dB
HT20, MCS0	-	37	-	dB
HT20, MCS7	-	20	-	dB

\*For the modules that use IPEX antennas, the output impedance is 50 $\Omega$ . For other modules without IPEX antennas, users do not need to concern about the output impedance.

## 5.5 BLE Radio

### 5.5.1 Receiver

**Table 9: Receiver Characteristics – BLE**

Parameter	Conditions	Min	Typ	Max	Unit
Sensitivity @30.8% PER	-	-	-97	-	dBm
Maximum received signal @30.8% PER	-	0	-	-	dBm
Co-channel C/I	-	-	+10	-	dB
Adjacent channel selectivity C/I	F = F0 + 1 MHz	-	-5	-	dB
	F = F0 - 1 MHz	-	-5	-	dB
	F = F0 + 2 MHz	-	-25	-	dB
	F = F0 - 2 MHz	-	-35	-	dB
	F = F0 + 3 MHz	-	-25	-	dB
	F = F0 - 3 MHz	-	-45	-	dB

Parameter	Conditions	Min	Typ	Max	Unit
Out-of-band blocking performance	30 MHz ~ 2000 MHz	-10	-	-	dBm
	2000 MHz ~ 2400 MHz	-27	-	-	dBm
	2500 MHz ~ 3000 MHz	-27	-	-	dBm
	3000 MHz ~ 12.5 GHz	-10	-	-	dBm
Intermodulation	-	-36	-	-	dBm

## 5.5.2 Transmitter

Table 10: Transmitter Characteristics – BLE

Parameter	Conditions	Min	Typ	Max	Unit
RF transmit power	-	-	0	-	dBm
Gain control step	-	-	3	-	dBm
RF power control range	-	-12	-	+12	dBm
Adjacent channel transmit power	$F = F_0 \pm 2 \text{ MHz}$	-	-52	-	dBm
	$F = F_0 \pm 3 \text{ MHz}$	-	-58	-	dBm
	$F = F_0 \pm > 3 \text{ MHz}$	-	-60	-	dBm
$\Delta f_{1\text{avg}}$	-	-	-	265	kHz
$\Delta f_{2\text{max}}$	-	247	-	-	kHz
$\Delta f_{2\text{avg}}/\Delta f_{1\text{avg}}$	-	-	-0.92	-	-
ICFT	-	-	-10	-	kHz
Drift rate	-	-	0.7	-	kHz/50 $\mu\text{s}$
Drift	-	-	2	-	kHz



## 5.6 Reflow Profile

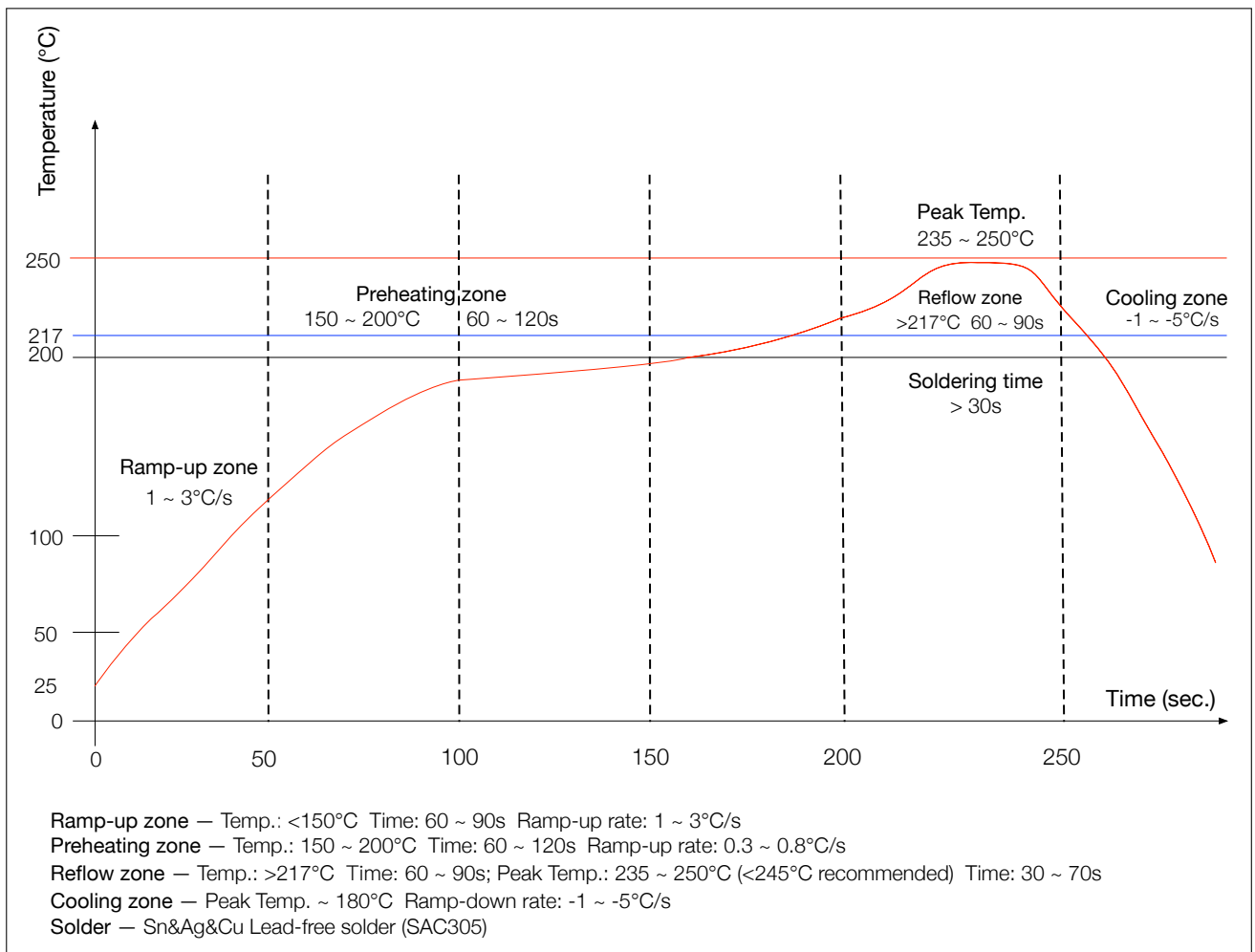

Figure 2: Reflow Profile

# 6. Schematics

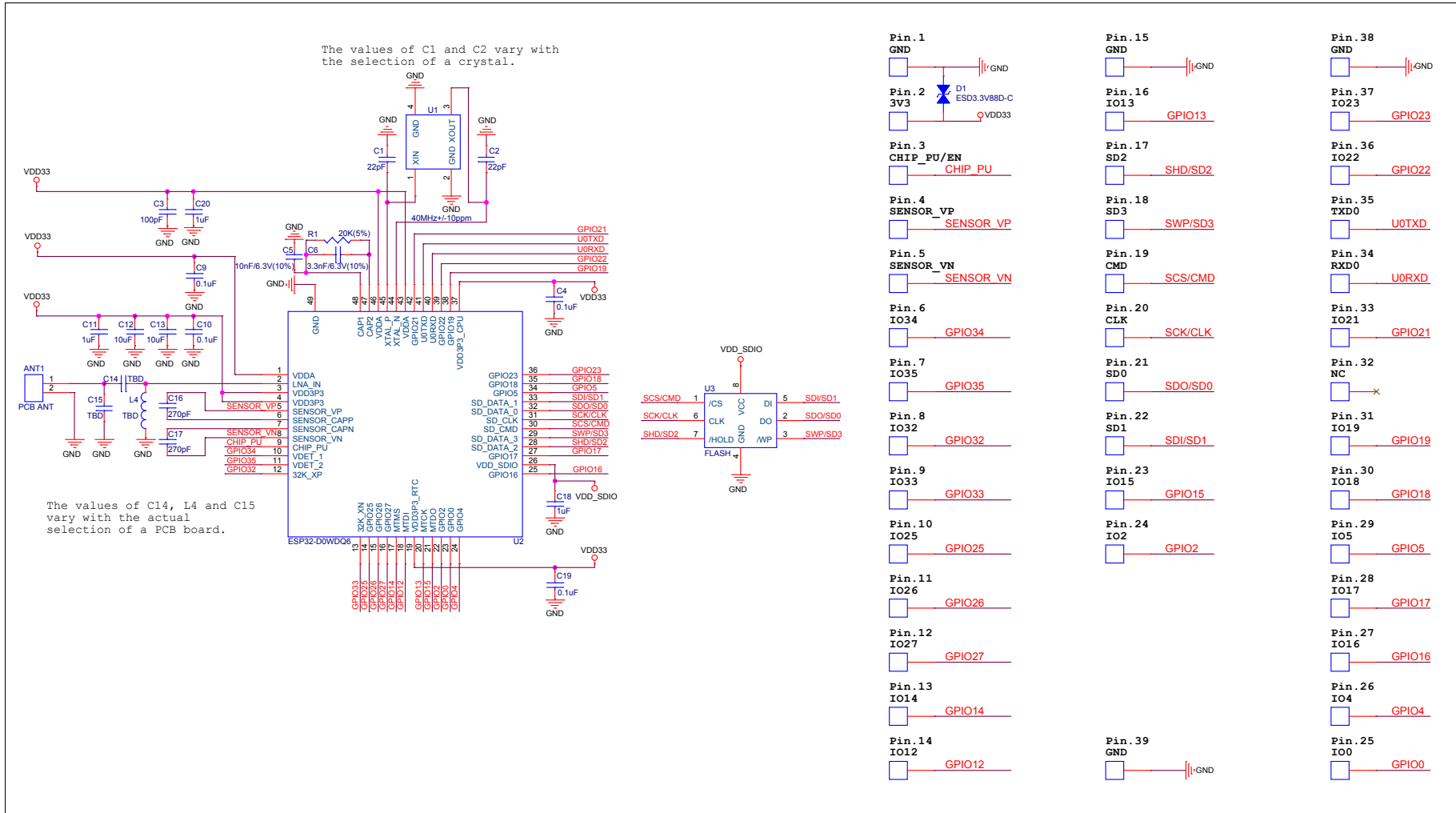

Figure 3: ESP32-WROOM-32 Schematics

## 7. Peripheral Schematics

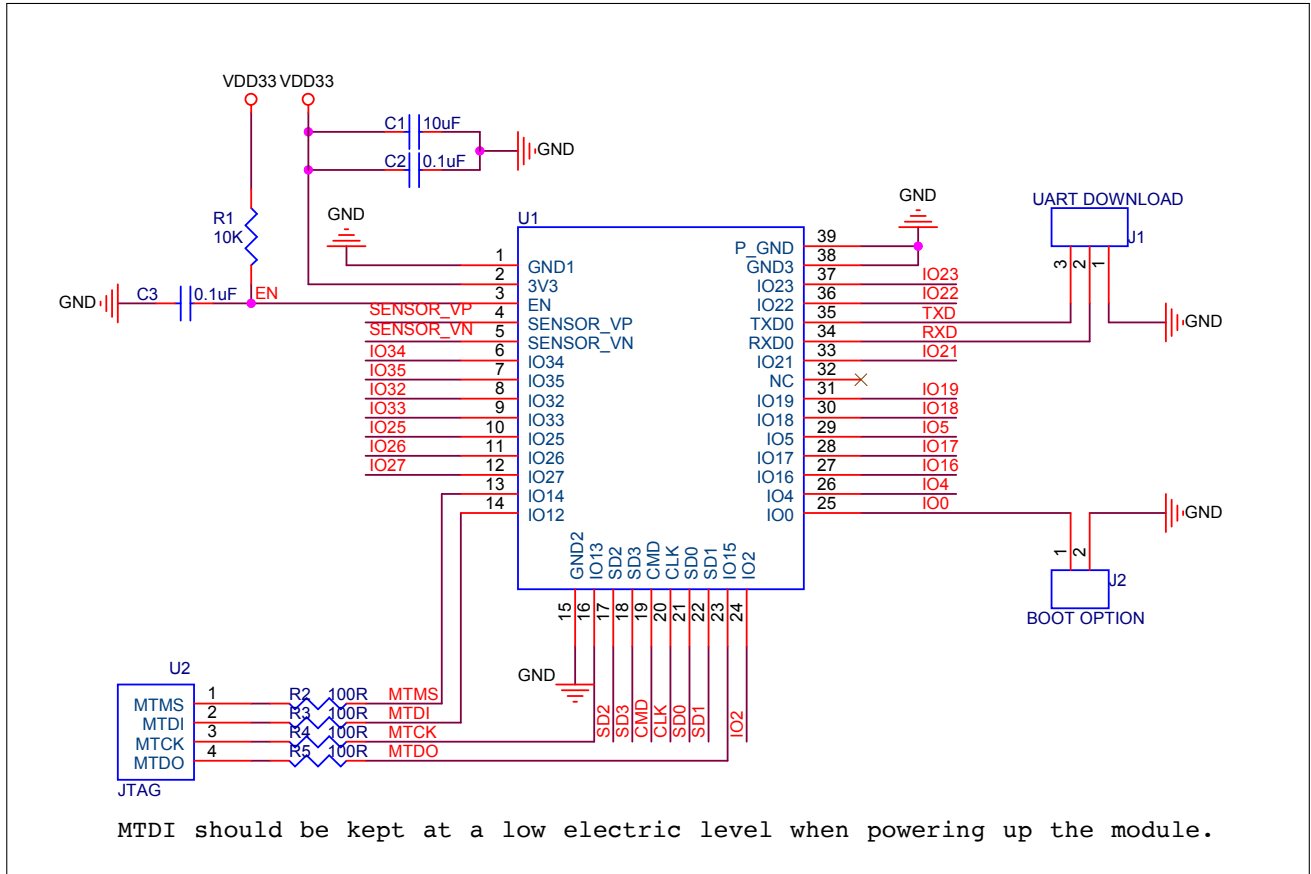

Figure 4: ESP32-WROOM-32 Peripheral Schematics

**Note:**

Soldering Pad 39 to the Ground of the base board is not necessary for a satisfactory thermal performance. If users do want to solder it, they need to ensure that the correct quantity of soldering paste is applied.

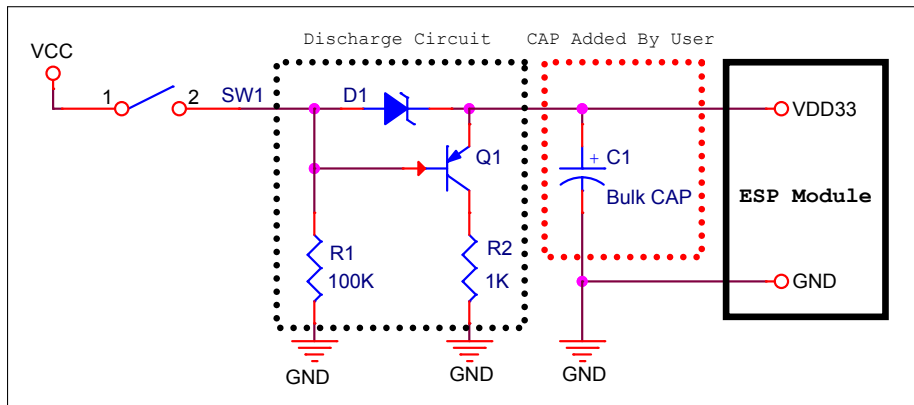
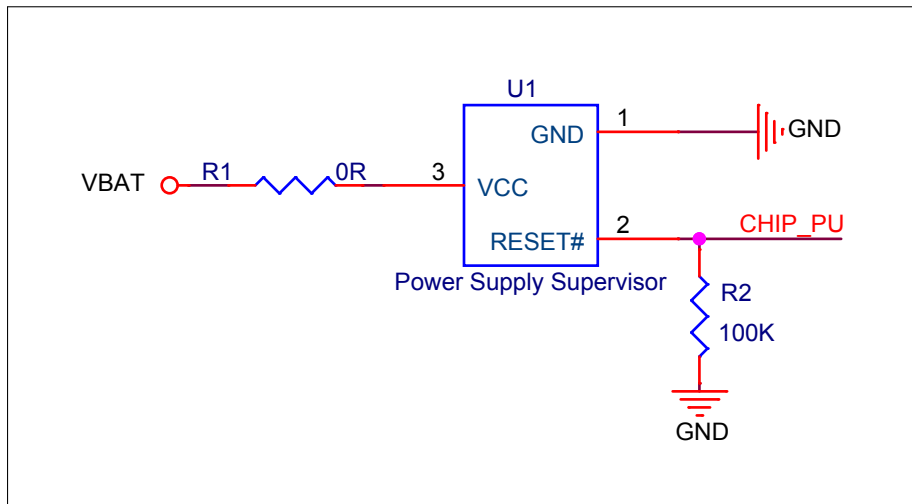

Figure 5: Discharge Circuit for VDD33 Rail

**Note:**

The discharge circuit can be applied in scenarios where ESP32 is powered on and off repeatedly by switching the power rails, and there is a large capacitor on the VDD33 rail. For details, please refer to Section **Power Scheme** in [ESP32 Datasheet](#).

**Figure 6: Reset Circuit****Note:**

When battery is used as the power supply for ESP32 series of chips and modules, a supply voltage supervisor is recommended to avoid boot failure due to low voltage. Users are recommended to pull CHIP\_PU low if the power supply for ESP32 is below 2.3V.

## 8. Physical Dimensions

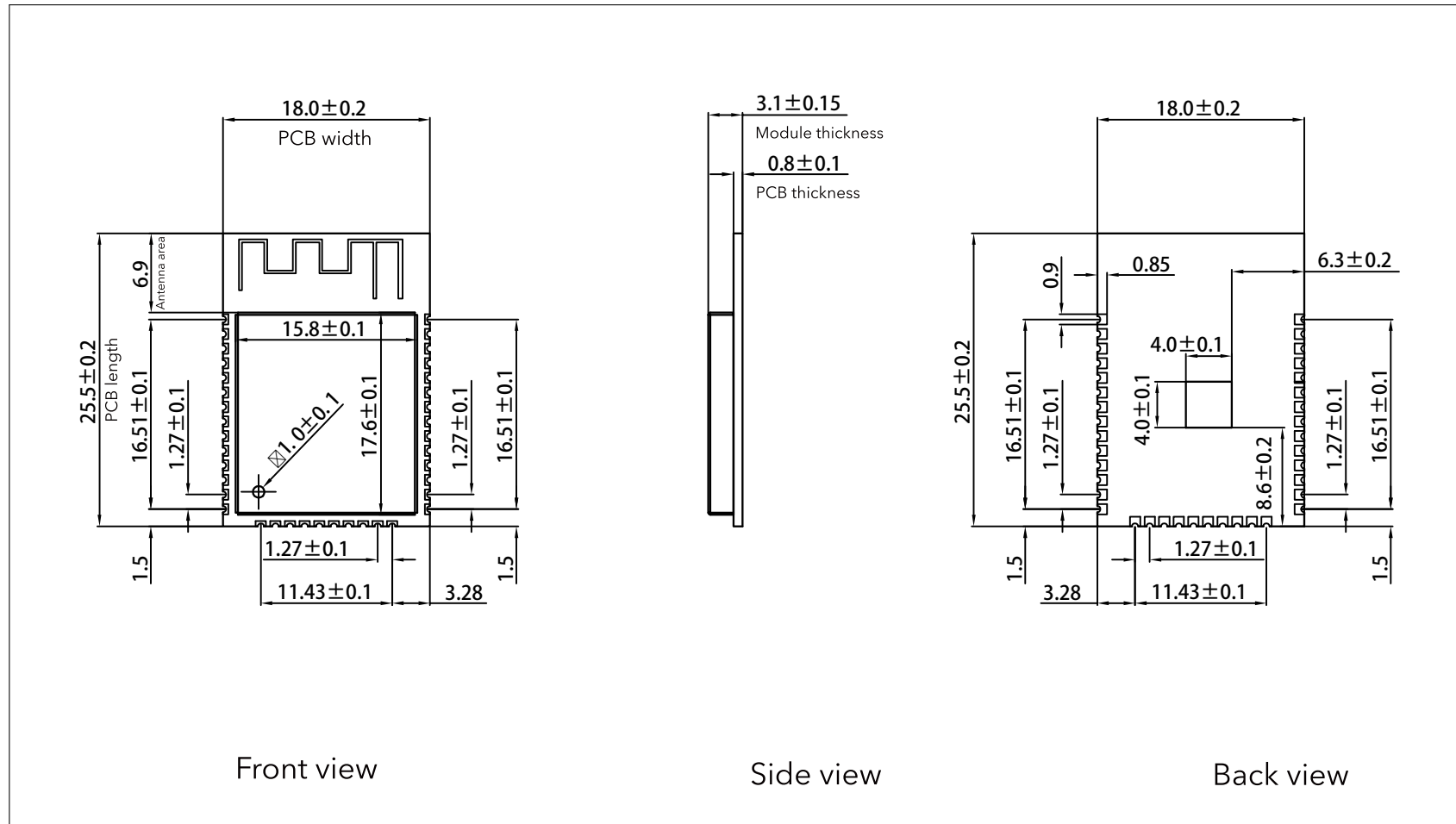

Figure 7: Physical Dimensions of ESP32-WROOM-32

**Note:**

All dimensions are in millimeters.

## 9. Recommended PCB Land Pattern

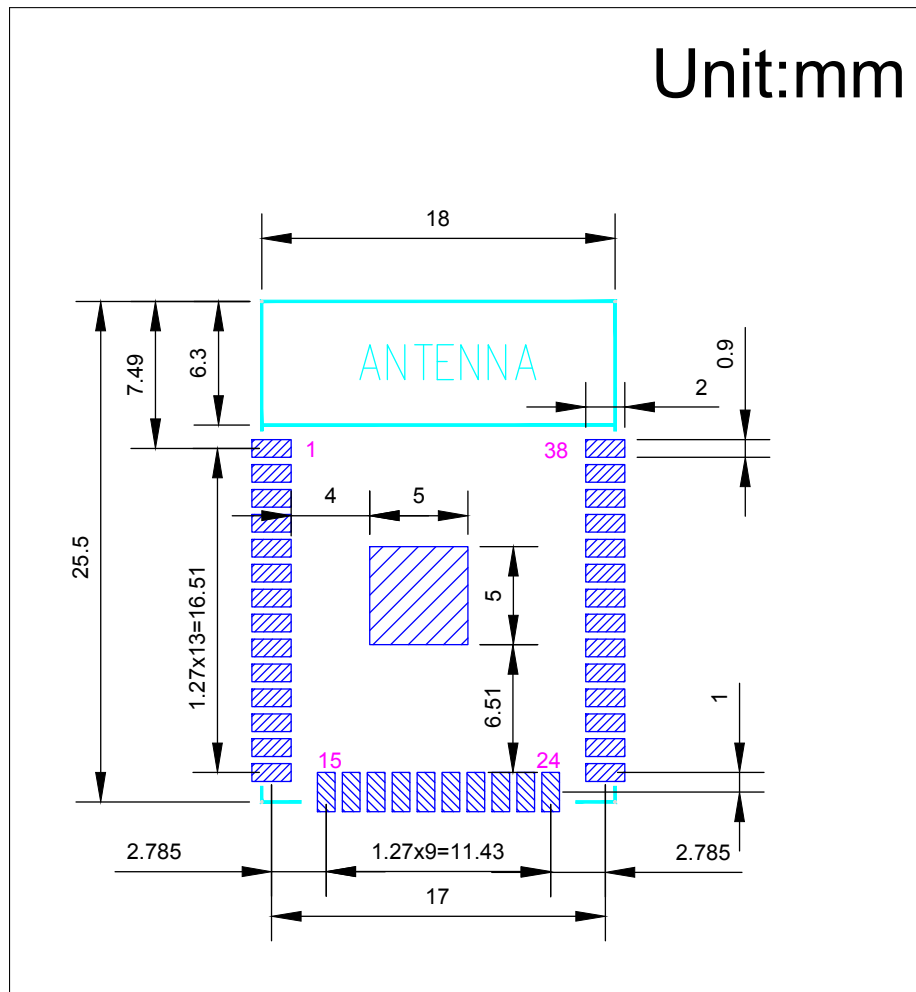

Figure 8: Recommended PCB Land Pattern

## 10. Learning Resources

### 10.1 Must-Read Documents

The following link provides documents related to ESP32.

- [ESP32 Datasheet](#)  
This document provides an introduction to the specifications of the ESP32 hardware, including overview, pin definitions, functional description, peripheral interface, electrical characteristics, etc.
- [ESP-IDF Programming Guide](#)  
It hosts extensive documentation for ESP-IDF ranging from hardware guides to API reference.
- [ESP32 Technical Reference Manual](#)  
The manual provides detailed information on how to use the ESP32 memory and peripherals.
- [ESP32 Hardware Resources](#)  
The zip files include the schematics, PCB layout, Gerber and BOM list of ESP32 modules and development boards.
- [ESP32 Hardware Design Guidelines](#)  
The guidelines outline recommended design practices when developing standalone or add-on systems based on the ESP32 series of products, including the ESP32 chip, the ESP32 modules and development boards.
- [ESP32 AT Instruction Set and Examples](#)  
This document introduces the ESP32 AT commands, explains how to use them, and provides examples of several common AT commands.
- [Espressif Products Ordering Information](#)

### 10.2 Must-Have Resources

Here are the ESP32-related must-have resources.

- [ESP32 BBS](#)  
This is an Engineer-to-Engineer (E2E) Community for ESP32 where you can post questions, share knowledge, explore ideas, and help solve problems with fellow engineers.
- [ESP32 GitHub](#)  
ESP32 development projects are freely distributed under Espressif's MIT license on GitHub. It is established to help developers get started with ESP32 and foster innovation and the growth of general knowledge about the hardware and software surrounding ESP32 devices.
- [ESP32 Tools](#)  
This is a webpage where users can download ESP32 Flash Download Tools and the zip file "ESP32 Certification and Test".
- [ESP-IDF](#)  
This webpage links users to the official IoT development framework for ESP32.
- [ESP32 Resources](#)  
This webpage provides the links to all available ESP32 documents, SDK and tools.

## Revision History

Date	Version	Release notes
2018.06	V2.5	<ul style="list-style-type: none"> <li>• Changed the module name to ESP32-WROOM-32;</li> <li>• Deleted Temperature Sensor in Table 1: ESP32-WROOM-32 Specifications;</li> <li>• Updated Chapter 3: Functional Description;</li> <li>• Added Chapter 8: Recommended PCB Land Pattern;</li> </ul> Changes to electrical characteristics: <ul style="list-style-type: none"> <li>• Updated Table 5: Absolute Maximum Ratings;</li> <li>• Added Table 6: Recommended Operating Conditions;</li> <li>• Added Table 7: DC Characteristics;</li> <li>• Updated the values of "Gain control step", "Adjacent channel transmit power" in Table 10: Transmitter Characteristics - BLE.</li> </ul>
2018.03	V2.4	Updated Table 1 in Chapter 1.
2018.01	V2.3	Deleted information on LNA pre-amplifier; Updated section 3.4 RTC and Low-Power Management; Added reset circuit in Chapter 7 and a note to it.
2017.10	V2.2	Updated the description of the chip's system reset in Section 2.3 Strapping Pins; Deleted "Association sleep pattern" in Table 4 and added notes to Active sleep and Modem-sleep; Updated the note to Figure 4 Peripheral Schematics; Added discharge circuit for VDD33 rail in Chapter 7 and a note to it.
2017.09	V2.1	Updated operating voltage/power supply range updated to 2.7 ~ 3.6V; Updated Chapter 7.
2017.08	V2.0	Changed the sensitivity of NZIF receiver to -97 dBm in Table 1; Updated the dimensions of the module; Updated Table 4 Power Consumption by Power Modes, and added two notes to it; Updated Table 5, 8, 9, 10; Added Chapter 8; Added the link to <a href="#">certification download</a> .
2017.06	V1.9	Added a note to Section 2.1 Pin Layout; Updated Section 3.3 Crystal Oscillators; Updated Figure 3 ESP-WROOM-32 Schematics; Added Documentation Change Notification.
2017.05	V1.8	Updated Figure 1 Top and Side View of ESP32-WROOM-32 (ESP-WROOM-32).
2017.04	V1.7	Added the module's dimensional tolerance; Changed the input impedance value of 50Ω in Table 8 Wi-Fi Radio Characteristics to output impedance value of 30+j10 Ω.
2017.04	V1.6	Added Figure 2 Reflow Profile.
2017.03	V1.5	Updated Section 2.2 Pin Description; Updated Section 3.2 External Flash and SRAM; Updated Section 4 Peripherals and Sensors Description.
2017.03	V1.4	Updated Chapter 1 Preface; Updated Chapter 2 Pin Definitions; Updated Chapter 3 Functional Description; Updated Table Recommended Operating Conditions;



Date	Version	Release notes
		Updated Table 8 Wi-Fi Radio Characteristics; Updated Section 5.6 Reflow Profile; Added Chapter 10 Learning Resources.
2016.12	V1.3	Updated Section 2.1 Pin Layout.
2016.11	V1.2	Added Figure 7 Peripheral Schematics.
2016.11	V1.1	Updated Chapter 6 Schematics.
2016.08	V1.0	First release.



## Стандарт Электрон Связь

Мы молодая и активно развивающаяся компания в области поставок электронных компонентов. Мы поставляем электронные компоненты отечественного и импортного производства напрямую от производителей и с крупнейших складов мира.

Благодаря сотрудничеству с мировыми поставщиками мы осуществляем комплексные и плановые поставки широчайшего спектра электронных компонентов.

Собственная эффективная логистика и склад в обеспечивает надежную поставку продукции в точно указанные сроки по всей России.

Мы осуществляем техническую поддержку нашим клиентам и предпродажную проверку качества продукции. На все поставляемые продукты мы предоставляем гарантию .

Осуществляем поставки продукции под контролем ВП МО РФ на предприятия военно-промышленного комплекса России , а также работаем в рамках 275 ФЗ с открытием отдельных счетов в уполномоченном банке. Система менеджмента качества компании соответствует требованиям ГОСТ ISO 9001.

Минимальные сроки поставки, гибкие цены, неограниченный ассортимент и индивидуальный подход к клиентам являются основой для выстраивания долгосрочного и эффективного сотрудничества с предприятиями радиоэлектронной промышленности, предприятиями ВПК и научно-исследовательскими институтами России.

С нами вы становитесь еще успешнее!

### Наши контакты:

**Телефон:** +7 812 627 14 35

**Электронная почта:** [sales@st-electron.ru](mailto:sales@st-electron.ru)

**Адрес:** 198099, Санкт-Петербург,  
Промышленная ул, дом № 19, литера Н,  
помещение 100-Н Офис 331