



**MCP43XXEV**  
**Evaluation Board**  
**User's Guide**

---

**Note the following details of the code protection feature on Microchip devices:**

- Microchip products meet the specification contained in their particular Microchip Data Sheet.
- Microchip believes that its family of products is one of the most secure families of its kind on the market today, when used in the intended manner and under normal conditions.
- There are dishonest and possibly illegal methods used to breach the code protection feature. All of these methods, to our knowledge, require using the Microchip products in a manner outside the operating specifications contained in Microchip's Data Sheets. Most likely, the person doing so is engaged in theft of intellectual property.
- Microchip is willing to work with the customer who is concerned about the integrity of their code.
- Neither Microchip nor any other semiconductor manufacturer can guarantee the security of their code. Code protection does not mean that we are guaranteeing the product as "unbreakable."

Code protection is constantly evolving. We at Microchip are committed to continuously improving the code protection features of our products. Attempts to break Microchip's code protection feature may be a violation of the Digital Millennium Copyright Act. If such acts allow unauthorized access to your software or other copyrighted work, you may have a right to sue for relief under that Act.

---

Information contained in this publication regarding device applications and the like is provided only for your convenience and may be superseded by updates. It is your responsibility to ensure that your application meets with your specifications. MICROCHIP MAKES NO REPRESENTATIONS OR WARRANTIES OF ANY KIND WHETHER EXPRESS OR IMPLIED, WRITTEN OR ORAL, STATUTORY OR OTHERWISE, RELATED TO THE INFORMATION, INCLUDING BUT NOT LIMITED TO ITS CONDITION, QUALITY, PERFORMANCE, MERCHANTABILITY OR FITNESS FOR PURPOSE. Microchip disclaims all liability arising from this information and its use. Use of Microchip devices in life support and/or safety applications is entirely at the buyer's risk, and the buyer agrees to defend, indemnify and hold harmless Microchip from any and all damages, claims, suits, or expenses resulting from such use. No licenses are conveyed, implicitly or otherwise, under any Microchip intellectual property rights.

**Trademarks**

The Microchip name and logo, the Microchip logo, dsPIC, KEELOQ, KEELOQ logo, MPLAB, PIC, PICmicro, PICSTART, PIC<sup>32</sup> logo, rPIC and UNI/O are registered trademarks of Microchip Technology Incorporated in the U.S.A. and other countries.


FilterLab, Hampshire, HI-TECH C, Linear Active Thermistor, MXDEV, MXLAB, SEEVAL and The Embedded Control Solutions Company are registered trademarks of Microchip Technology Incorporated in the U.S.A.

Analog-for-the-Digital Age, Application Maestro, CodeGuard, dsPICDEM, dsPICDEM.net, dsPICworks, dsSPEAK, ECAN, ECONOMONITOR, FanSense, HI-TIDE, In-Circuit Serial Programming, ICSP, Mindi, MiWi, MPASM, MPLAB Certified logo, MPLIB, MPLINK, mTouch, Octopus, Omniscient Code Generation, PICC, PICC-18, PICDEM, PICDEM.net, PICKit, PICtail, PIC<sup>32</sup> logo, REAL ICE, rLAB, Select Mode, Total Endurance, TSHARC, UniWinDriver, WiperLock and ZENA are trademarks of Microchip Technology Incorporated in the U.S.A. and other countries.

SQTP is a service mark of Microchip Technology Incorporated in the U.S.A.

All other trademarks mentioned herein are property of their respective companies.

© 2010, Microchip Technology Incorporated, Printed in the U.S.A., All Rights Reserved.

 Printed on recycled paper.

ISBN: 978-1-60932-397-4

**QUALITY MANAGEMENT SYSTEM**  
**CERTIFIED BY DNV**  
**== ISO/TS 16949:2002 ==**

*Microchip received ISO/TS-16949:2002 certification for its worldwide headquarters, design and wafer fabrication facilities in Chandler and Tempe, Arizona; Gresham, Oregon and design centers in California and India. The Company's quality system processes and procedures are for its PIC<sup>®</sup> MCUs and dsPIC<sup>®</sup> DSCs, KEELOQ<sup>®</sup> code hopping devices, Serial EEPROMs, microperipherals, nonvolatile memory and analog products. In addition, Microchip's quality system for the design and manufacture of development systems is ISO 9001:2000 certified.*



# MCP43XXEV EVALUATION BOARD USER'S GUIDE

---

---

## Table of Contents

---

---

<b>Preface</b> .....	<b>5</b>
<b>Chapter 1. Product Overview</b>	
1.1 Introduction .....	9
1.2 What is the MCP43XXEV Evaluation Board? .....	9
1.3 What the MCP43XXEV Evaluation Board Kit Includes .....	10
<b>Chapter 2. Installation and Operation</b>	
2.1 Introduction .....	11
2.2 Features .....	12
2.3 Getting Started .....	13
2.4 MCP43XXEV Evaluation Board Description .....	13
2.5 Configuring The PICkit Serial Analyzer .....	19
2.6 MCP4361 Demo Steps .....	28
<b>Appendix A. Schematic and Layouts</b>	
A.1 Introduction .....	33
A.2 Schematics and PCB Layout .....	33
A.3 Board – Schematic .....	34
A.4 Board – Top Trace, Silk and Pads .....	35
A.5 Board – Bottom Trace and Pads .....	36
A.6 Board – Layer 2 Ground Plane .....	37
A.7 Board – Layer 3 Power Plane .....	38
A.8 Board Layout – Top Components .....	39
A.9 Board – Bottom Silk, Trace and Pads .....	40
<b>Appendix B. Bill of Materials (BOM)</b>	
<b>Worldwide Sales and Service</b> .....	<b>42</b>

# MCP43XXEV Evaluation Board User's Guide

---

---

NOTES:



# MCP43XXEV EVALUATION BOARD USER'S GUIDE

---

---

## Preface

---

---

### NOTICE TO CUSTOMERS

All documentation becomes dated, and this manual is no exception. Microchip tools and documentation are constantly evolving to meet customer needs, so some actual dialogs and/or tool descriptions may differ from those in this document. Please refer to our web site ([www.microchip.com](http://www.microchip.com)) to obtain the latest documentation available.

Documents are identified with a "DS" number. This number is located on the bottom of each page, in front of the page number. The numbering convention for the DS number is "DSXXXXA", where "XXXX" is the document number and "A" is the revision level of the document.

For the most up-to-date information on development tools, see the MPLAB® IDE on-line help. Select the Help menu, and then Topics to open a list of available on-line help files.

## INTRODUCTION

This chapter contains general information that will be useful to know before using the MCP43XXEV Evaluation Board. Items discussed in this chapter include:

- Document Layout
- Conventions Used in this Guide
- The Microchip Web Site
- Customer Support
- Document Revision History

## DOCUMENT LAYOUT

This document describes how to use the MCP43XXEV Evaluation Board as a development tool to emulate and debug firmware on a target board. The manual layout is as follows:

- **Chapter 1. "Product Overview"** – Important information about the MCP43XXEV Evaluation Board.
- **Chapter 2. "Installation and Operation"** – Includes instructions on how to get started with this evaluation board.
- **Appendix A. "Schematic and Layouts"** – Shows the schematic and layout diagrams for the MCP43XXEV Evaluation Board.
- **Appendix B. "Bill of Materials (BOM)"** – Lists the parts used to build the MCP43XXEV Evaluation Board.

## CONVENTIONS USED IN THIS GUIDE

This manual uses the following documentation conventions:

### DOCUMENTATION CONVENTIONS

Description	Represents	Examples
<b>Arial font:</b>		
Italic characters	Referenced books	<i>MPLAB<sup>®</sup> IDE User's Guide</i>
	Emphasized text	...is the <i>only</i> compiler...
Initial caps	A window	the Output window
	A dialog	the Settings dialog
	A menu selection	select Enable Programmer
Quotes	A field name in a window or dialog	"Save project before build"
Underlined, italic text with right angle bracket	A menu path	<u><i>File&gt;Save</i></u>
Bold characters	A dialog button	Click <b>OK</b>
	A tab	Click the <b>Power</b> tab
N'Rnnnn	A number in verilog format, where N is the total number of digits, R is the radix and n is a digit.	4'b0010, 2'hF1
Text in angle brackets < >	A key on the keyboard	Press <Enter>, <F1>

## RECOMMENDED READING

This User's Guide describes how to use the MCP43XXEV Evaluation Board. Other useful documents are listed below. The following Microchip documents are available and recommended as supplemental reference resources.

**AN1080 Application Note, “Understanding Digital Potentiometer Resistor Variations”, DS01080**

**AN1316 Application Note, “Using Digital Potentiometers for Programmable Amplifier Gain”, DS01316**

These data sheets provide detailed information regarding the MCP43xx product family:

**MCP433X/5X Data Sheet, “7/8-Bit Quad SPI Digital POT with Volatile Memory”, DS22242**

**MCP434X/6X Data Sheet, “7/8-Bit Quad SPI Digital POT with Non-Volatile Memory”, DS22233**

## THE MICROCHIP WEB SITE

Microchip provides online support via our web site at [www.microchip.com](http://www.microchip.com). This web site is used as a means to make files and information easily available to customers. Accessible by using your favorite Internet browser, the web site contains the following information:

- **Product Support** – Data sheets and errata, application notes and sample programs, design resources, user's guides and hardware support documents, latest software releases and archived software
- **General Technical Support** – Frequently Asked Questions (FAQs), technical support requests, online discussion groups, Microchip consultant program member listing
- **Business of Microchip** – Product selector and ordering guides, latest Microchip press releases, listing of seminars and events, listings of Microchip sales offices, distributors and factory representatives

## CUSTOMER SUPPORT

Users of Microchip products can receive assistance through several channels:

- Distributor or Representative
- Local Sales Office
- Field Application Engineer (FAE)
- Technical Support
- Development Systems Information Line

Customers should contact their distributor, representative or field application engineer (FAE) for support. Local sales offices are also available to help customers. A listing of sales offices and locations is included in the back of this document.

Technical support is available through the web site at: <http://support.microchip.com>

In addition, there is a Development Systems Information Line which lists the latest versions of Microchip's development systems software products. This line also provides information on how customers can receive currently available upgrade kits.

The Development Systems Information Line numbers are:

1-800-755-2345 – United States and most of Canada

1-480-792-7302 – Other International Locations

## DOCUMENT REVISION HISTORY

### Revision A (July 2010)

- Initial Release of this Document.



---

---

## Chapter 1. Product Overview

---

---

### 1.1 INTRODUCTION

This chapter provides an overview of the MCP43XXEV Evaluation Board and covers the following topics:

- What is the MCP43XXEV Evaluation Board?
- What the MCP43XXEV Evaluation Board kit includes

### 1.2 WHAT IS THE MCP43XXEV EVALUATION BOARD?

The MCP43XXEV Evaluation Board allows the system designer to quickly evaluate the operation of Microchip Technology's MCP4361 Digital Potentiometer device. This device is similar to the following devices:

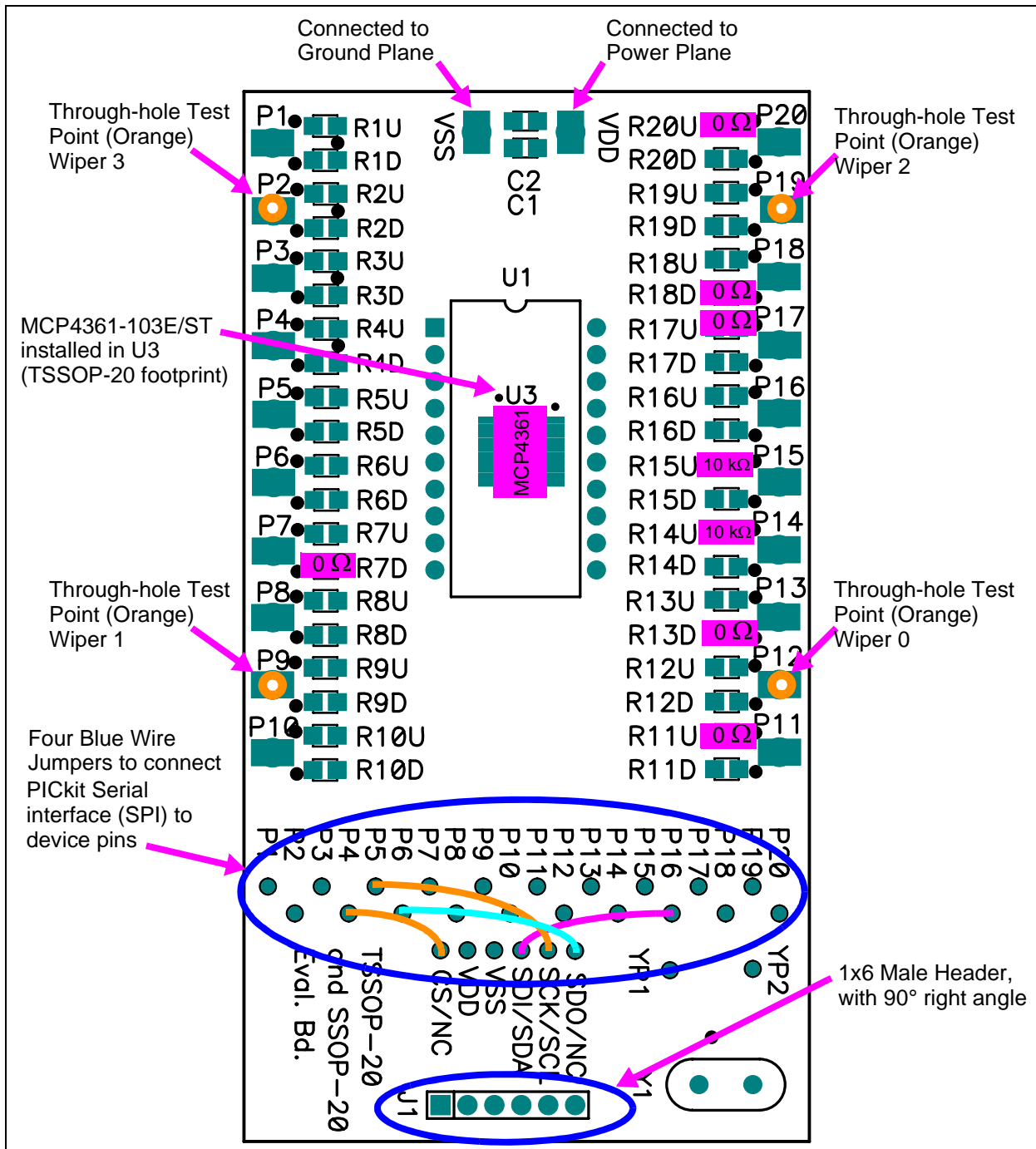
- MCP4331
- MCP4332
- MCP4341
- MCP4342
- MCP4351
- MCP4352
- MCP4362
- MCP4231
- MCP4232
- MCP4241
- MCP4242
- MCP4251
- MCP4252
- MCP4261
- MCP4262

The board uses the TSSOP20EV Generic PCB and has been populated for the MCP4361. The 6-pin header (PICkit Serial) has been jumpered to the MCP4361's appropriate pins. This allows the PICkit Serial to communicate with the device.

Additional blank PCBs may be ordered by using the order number: TSSOP20EV. Each TSSOP20EV kit contains 5 PCBs.

Figure 1-1 shows the top view of the populated TSSOP20EV PCB, which creates the MCP43XXEV Evaluation Board.

# MCP43XXEV Evaluation Board User's Guide



**FIGURE 1-1:** MCP43XXEV Evaluation Board Using the TSSOP20EV Evaluation Board (MCP4361 installed in U3).

## 1.3 WHAT THE MCP43XXEV EVALUATION BOARD KIT INCLUDES

This MCP43XXEV Evaluation Board kit includes:

- MCP43XXEV Evaluation Board
- One TSSOP-20 and SSOP-20 Evaluation Board blank PCB, 102-00272. Extra blank PCBs can be ordered (order #: TSSOP20EV)
- Important Information Sheet

---

---

## Chapter 2. Installation and Operation

---

---

### 2.1 INTRODUCTION

The MCP43XXEV Evaluation Board allows the system designer to quickly evaluate the operation of the MCP4361 10 k $\Omega$  (-103) Digital Potentiometer device using the PICkit Serial Analyzer. The PICkit Serial Analyzer is available separately (order number: DV164122).

This board is a minimum configuration for the device. As well as the device, other desired passive components (resistors and capacitors) and connection posts may be installed.

The board can also be very easily jumpered into a customer's existing circuit. This gives an indication of the MCP4361 device performance, but is affected by the jumper lead length and the EM noise that the jumpers pick up.

The device's resistor networks 0 and 2 have been configured in a potentiometer mode with the A terminal connected to  $V_{DD}$  through a 0 $\Omega$  resistor and the B terminal connected to  $V_{SS}$  with a 0 $\Omega$  resistor. Resistor networks 1 and 3 can be evaluated for rheostat operation.

The MCP43XXEV Evaluation Board uses the generic TSSOP20EV Evaluation Board PCB. The kit includes a second PCB which is blank for the user to populate as desired. Additional PCBs may be ordered (order number: TSSOP20EV). The TSSOP20EV kit includes 5 blank PCBs.

Other boards can easily be built up using the TSSOP20EV PCB to allow evaluation of other resistance options (5 k $\Omega$ , 50 k $\Omega$ , or 100 k $\Omega$ ) or any of the other digital potentiometer devices in the following packages:

- TSSOP-20 package
  - MCP4331, MCP4341, MCP4351, or MCP4361
- TSSOP-14 package
  - MCP4332, MCP4342, MCP4352, MCP4362, MCP4231, MCP4241, MCP4251, MCP4261, MCP4631, MCP4641, MCP4651, MCP4661, MCP42010, MCP42050, or MCP42100

The board also has a 6-pin interface (PICkit Serial, ICSP, etc.) whose signals can easily be jumpered to any of the device's pins.

Additional information on using the TSSOP20EV Evaluation Board PCB or for modifying the MCP43XXEV board is available in the TSSOP20EV User's Guide (DS51875).

**Appendix A. "Schematic and Layouts"** has information of the PCB schematic and layout while Figure 2-2 shows components that are installed on the PCB.

## 2.2 FEATURES

The MCP43XXEV Evaluation Board has the following features:

- MCP4361-103E/ST is installed
- $0\Omega$  resistors connect MCP4361  $V_{DD}$  and  $V_{SS}$  signals to the appropriate Power or Ground plane (see Figure 2-2)
- $0\Omega$  resistors connect MCP4361's Resistor Network 0 and 2 A terminal signal to Power plane, Resistor Network is in a voltage divider configuration (see Figure 2-2)
- $0\Omega$  resistors connect MCP4361's Resistor Network 0 and 2 B terminal signal to Ground plane, Resistor Network is in a voltage divider configuration (see Figure 2-2)
- Through-hole connection terminal (Orange) for all Wiper pins
- Connection terminal points for all device pins (either through-hole or surface-mount)
- Footprints for optional passive components (SMT 805 footprint) for:
  - Power supply filtering ( $C_1$  and  $C_2$  footprints)
  - Device bypass capacitor (RxD footprint for device pin connected to  $V_{DD}$ )
- Silk-screen area to write specifics of implemented circuit (on back of PCB), such as MCP4361 10 k $\Omega$
- PICKit Serial Analyzer Header

The included TSSOP20EV Board has the following features:

- Connection terminals may be either through-hole or surface-mount
- Three package type footprints supported:
  - TSSOP-20
  - TSSOP-14
  - TSSOP-8
  - SSOP-20
  - DIP-20 (600 mil body)
- Footprints for optional passive components (SMT 805 footprint) for:
  - Power supply filtering ( $C_1$  and  $C_2$  footprints)
  - Device bypass capacitor (RxD footprint for device pin connected to  $V_{DD}$ )
  - Output filtering (RxD footprint)
  - Output pull-up resistor (RxU footprint)
  - Output pull-down resistor (RxD footprint)
  - Output loading resistor (RxD footprint)
- Silk-screen area to write specifics of implemented circuit (on back of PCB), such as MCP4361 10 k $\Omega$
- PICKit Serial Analyzer / PICKit 2 Programming (ICSP) Header

## 2.3 GETTING STARTED

The MCP43XXEV Evaluation Board allows quick evaluation of the MCP4361-103E/ST device. The understanding of the device characteristics (such as the resistor network) is applicable to any of the devices in the MCP43XX family. The MCP4361-103 device has a typically  $R_{AB}$  resistance of 10 k $\Omega$ . Evaluation can be done by:

- Using the PICkit Serial Analyzer for interface communication
- Jumpering the MCP43XXEV Evaluation Board into your application circuit to control the MCP4361-103 device

This User Guide will discuss the steps needed to evaluate the MCP4361-103E/ST device using the PICkit Serial Analyzer (order number: DV164122).

**Section 2.5 “Configuring The PICkit Serial Analyzer”** shows the steps to configure the PICkit Serial Analyzer as well as create User Script files which are used to communicate with the MCP4361, based on the devices SPI communication protocol format.

## 2.4 MCP43XXEV EVALUATION BOARD DESCRIPTION

The MCP43XXEV Evaluation Board uses the flexible TSSOP20EV Evaluation Board PCB. This simple Evaluation Board allows the system designer to quickly evaluate the operation of the MCP4361-103 device ( $R_{AB(TYP)} = 10 \text{ k}\Omega$ ) using the PICkit Serial Analyzer or by jumpering the board into their application system. The PICkit Serial Analyzer is available separately (order number: DV164122).

### 2.4.1 The Hardware

Figure 2-2 shows the component layout of the MCP43XXEV Evaluation Board. This is a small four-layer board ( 3.9" x 2.1" (99.06 mm x 53.34 mm)). There are twenty two connection points/pads that can use either through-hole or surface-mount connector posts.

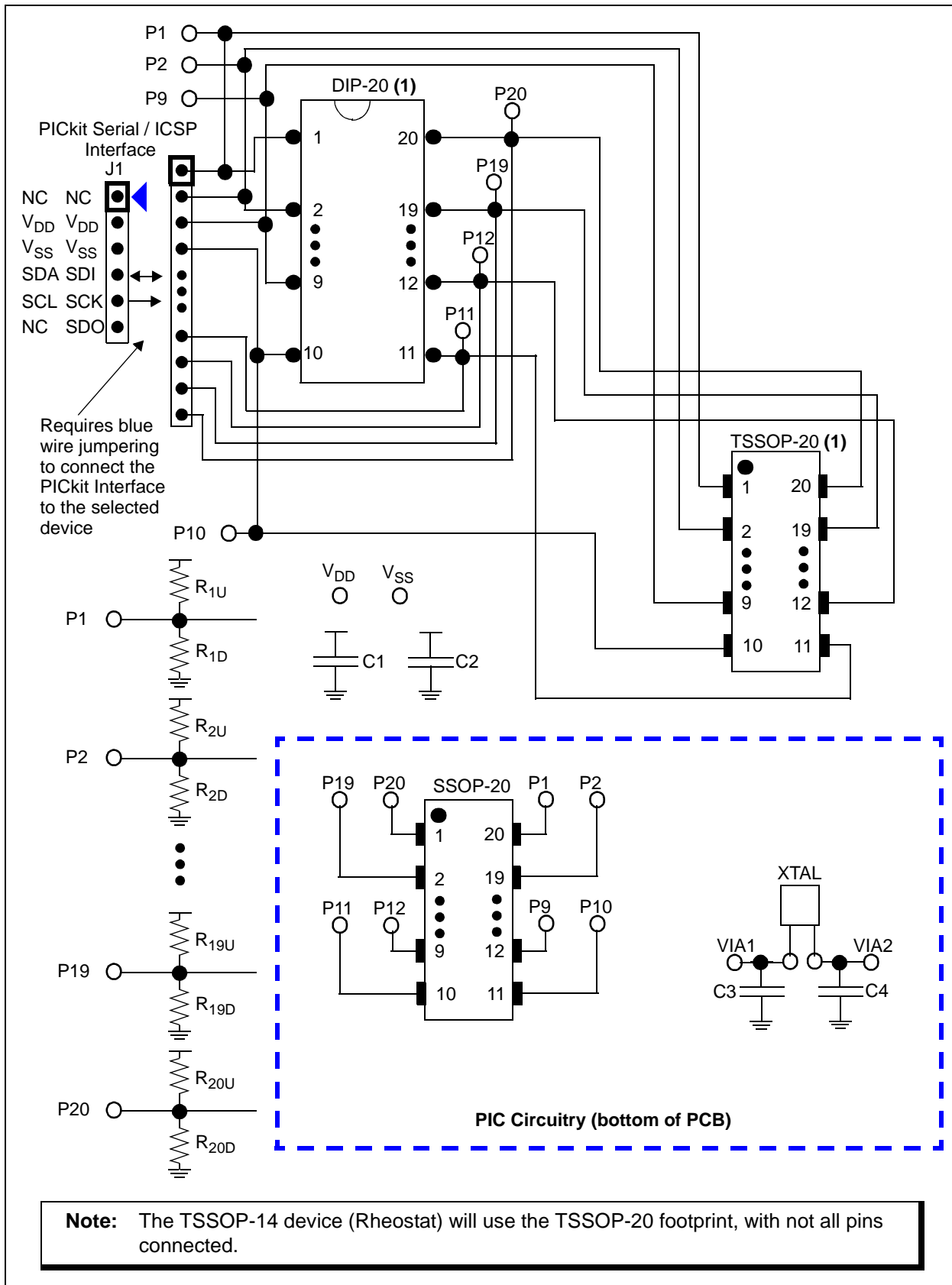
The pad labeled  $V_{DD}$  is connected to the PCB power plane, while the pad labeled  $V_{SS}$  is connected to the PCB ground plane. All the passive components that are connected to  $V_{DD}$  or  $V_{SS}$  are connected to either the power plane or ground plane.

The twenty remaining PCB pads correspond to the device pins (i.e.; pad 1 connects to pin 1).

Each pad has two passive components associated with them: a pull-up resistor and a pull-down resistor. The pull-up resistor is always RXU and the pull-down resistor is RXD. The “X” is a numeric value that corresponds to a particular pad (1 to 8). As an example, Pad 5’s pull-up resistor is R5U. Capacitor C1 and C2 are the power supply filtering capacitors. For whichever pin is the device’s  $V_{DD}$ , the RxD component footprint can be used for the device’s bypass capacitor. Table 2-2 describes the components.

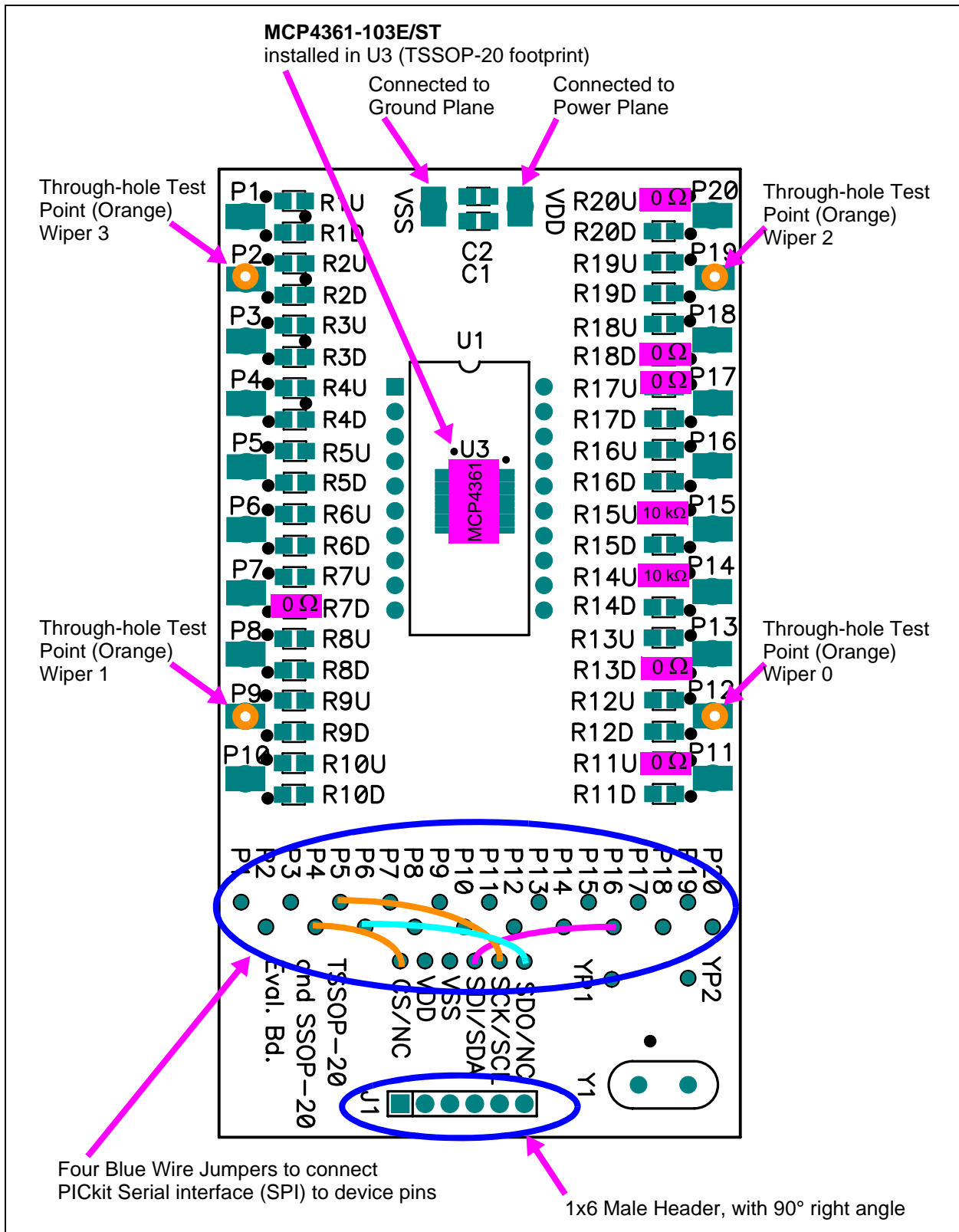
A 6-pin header interface is available to support the PICkit Serial or the PIC MCU In-Circuit Serial Programming (ICSP) interface.

# MCP43XXEV Evaluation Board User's Guide



**FIGURE 2-1:** TSSOP20EV Evaluation Board Circuit.

# Installation and Operation



**FIGURE 2-2:** MCP43XXEV Evaluation Board Component Placement Using the TSSOP20EV Evaluation Board (Top).

# MCP43XXEV Evaluation Board User's Guide

**TABLE 2-1: INSTALLED PASSIVE COMPONENTS (2)**

Component	Description	Comment
R11U, R17U, R20U	0Ω SMT 805	Pull-up resistor
R14U, R15U	10 kΩ SMT 805	Pull-up resistor
R7D, R13D, R18D	0Ω SMT 805	Pull-down resistor (1)
U3	MCP4361-103E/ST	$R_{AB(TYP)} = 10\text{ k}\Omega$
P2, P9, P12, P19	Test Point - through-hole connector (Orange)	
J1	1x6 Male Header, 100 mil spacing 90° angle.	PICkit Serial / ICSP header
—	Blue Wire: J1 CS/NC via to P4 via J1 SDI/SDA via to P16 via J1 SCK/SCL via to P5 via J1 SDO/NC via to P6 via	See Figure 2-2

- Note 1:** Whichever pin is the device's  $V_{DD}$  pin, that corresponding RXD footprint can be used for the device's bypass capacitor. So if Pin 8 is the device's  $V_{DD}$  pin, then install the bypass capacitor in the R8D footprint.
- 2:** All passive components use the surface mount 805 footprint.



**TABLE 2-2: OPTIONAL PASSIVE COMPONENTS - NOT INSTALLED <sup>(2)</sup>**

Component	Comment
C1, C2	Power supply bypass capacitors <sup>(3)</sup>
C3, C4	PIC Crystal capacitors
R1U, R2U, R3U, R4U, R5U, R6U, R7U, R8U, R9U, R12U, R13U, R16U, R18U, R19U	Pull-up resistor
R1D, R2D, R3D, R4D, R5D, R6D, R8D, R9D, R10D, R11D, R12D, R14D, R15D, R16D, R17D, R19D, R20D	Pull-down resistor <sup>(1)</sup>
U1, U2	Alternate package footprints
VDD, GND	Power and Ground plane connection points
Y1	Can connect to either PIC' main oscillator or to the Timer oscillator circuit.
P1, P3, P4, P5, P6, P8, P10, P11, P13, P14, P15, P16, P17, P18, P20	Test Point connectors

**Note 1:** Whichever pin is the device's  $V_{DD}$  pin, that corresponding RXD footprint can be used for the device's bypass capacitor. So if Pin 8 is the device's  $V_{DD}$  pin, then install the bypass capacitor in the R8D footprint.

**2:** All passive components use the surface mount 805 footprint.

**3:** If the board is powered via the  $V_{DD}$  and GND connection points, the use of bypass capacitors on C1 and C2 may improve performance. The benefit is reduced if the board is powered via the PICKit Serial interface.

# MCP43XXEV Evaluation Board User's Guide

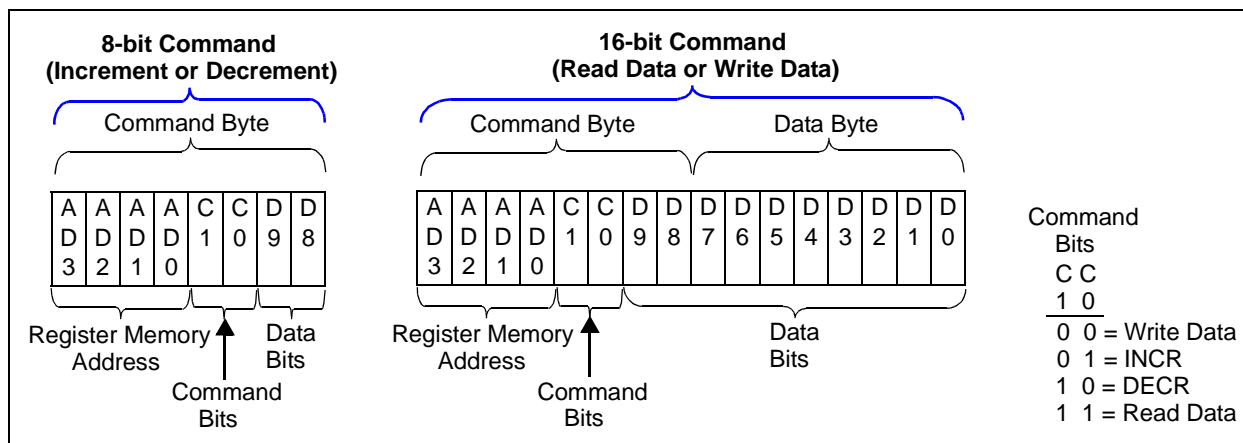
## 2.4.2 The MCP4361 Device

To make variations to the commands sent to the MCP4361 device (from the commands shown in the demo section), one must know the device memory map (see Table 2-3) and the command formats (see Figure 2-3). For additional device operational information, refer to the MCP4361 device data sheet (DS22233).

**TABLE 2-3: MEMORY MAP AND THE SUPPORTED COMMANDS**

Address	Function	Memory Type	Allowed Commands	Disallowed Commands <sup>(2)</sup>
00h	Volatile Wiper 0	RAM	Read, Write, Increment, Decrement	—
01h	Volatile Wiper 1	RAM	Read, Write, Increment, Decrement	—
02h	Non-Volatile Wiper 0	EEPROM	Read, Write <sup>(1)</sup>	Increment, Decrement
03h	Non-Volatile Wiper 1	EEPROM	Read, Write <sup>(1)</sup>	Increment, Decrement
04h	Volatile TCON0 Register	RAM	Read, Write	Increment, Decrement
05h	Status Register	RAM	Read	Write, Increment, Decrement
06h	Volatile Wiper 2	RAM	Read, Write, Increment, Decrement	—
07h	Volatile Wiper 3	RAM	Read, Write, Increment, Decrement	—
08h	Non-Volatile Wiper 2	EEPROM	Read, Write <sup>(1)</sup>	Increment, Decrement
09h	Non-Volatile Wiper 3	EEPROM	Read, Write <sup>(1)</sup>	Increment, Decrement
0Ah	Volatile TCON1 Register	RAM	Read, Write	Increment, Decrement
0Bh - 0Fh	Data EEPROM	EEPROM	Read, Write <sup>(1)</sup>	Increment, Decrement

- Note 1:** When an EEPROM write is active, these are invalid commands and will generate an error condition. The user should use a read of the Status register to determine when the write cycle has completed. To exit the error condition, the user must take the  $\overline{CS}$  pin to the  $V_{IH}$  level and then back to the active state ( $V_{IL}$  or  $V_{IHH}$ ).
- 2:** This command on this address will generate an error condition. To exit the error condition, the user must take the  $\overline{CS}$  pin to the  $V_{IH}$  level and then back to the active state ( $V_{IL}$  or  $V_{IHH}$ ).



**FIGURE 2-3:** MCP43XX SPI Command Formats.

## 2.5 CONFIGURING THE PICKIT SERIAL ANALYZER

### 2.5.1 Modifying the “CommScripts.txt” file

Example 2-1 shows the User Scripts that need to be added to the PICkit Serial’s “CommScripts.txt” file. The default install location of this file is:

C:\Program Files\Microchip\PICkit Serial Analyzer

Once these are saved in the “CommScripts.txt” file and the Master SPI mode is selected as the communication mode, these user scripts will be available to select from.

#### NOTICE

**Note 1:** It is recommended that you make a backup of your “CommScript.txt” file before making any edits with a text editor.

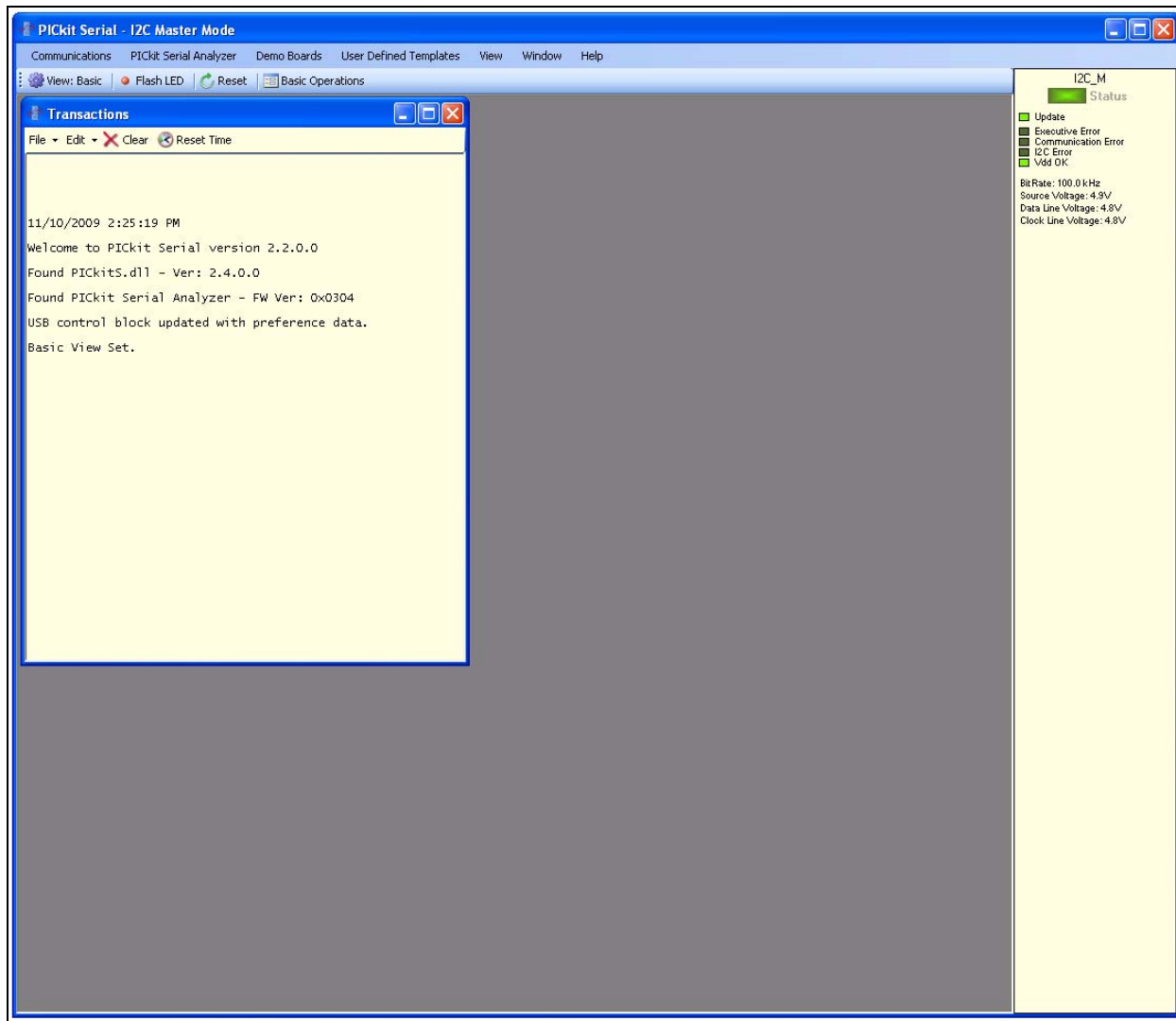
**2:** It has been observed that copying the text from this PDF and pasting into the PICkit Serial’s “CommScript.txt” file will cause errors due to the blank spacing used in the PDF file. Please copy from the “MCP43XX Com-mScript.txt” file available from the Microchip web site.

#### EXAMPLE 2-1: MCP43XX SCRIPT FILE (COMMSRIPTS.TXT)

WriteWiper0	SPI	SPICSON	SPIDATOUT	0x02	0x00	0x3F	SPICSOFF
ReadWiper0	SPI	SPICSON	SPIDATIO	0x02	0x0C	0xA5	SPICSOFF
WriteWiper1	SPI	SPICSON	SPIDATOUT	0x02	0x10	0x3F	SPICSOFF
ReadWiper1	SPI	SPICSON	SPIDATIO	0x02	0x1C	0xA5	SPICSOFF
WriteWiper2	SPI	SPICSON	SPIDATOUT	0x02	0x60	0x3F	SPICSOFF
ReadWiper2	SPI	SPICSON	SPIDATIO	0x02	0x6C	0xA5	SPICSOFF
WriteWiper3	SPI	SPICSON	SPIDATOUT	0x02	0x70	0x3F	SPICSOFF
ReadWiper3	SPI	SPICSON	SPIDATIO	0x02	0x7C	0xA5	SPICSOFF
WriteWiper0NV	SPI	SPICSON	SPIDATOUT	0x02	0x20	0x3F	SPICSOFF
ReadWiper0NV	SPI	SPICSON	SPIDATIO	0x02	0x2C	0xA5	SPICSOFF
WriteTCON0	SPI	SPICSON	SPIDATOUT	0x02	0x40	0xFF	SPICSOFF
ReadTCON0	SPI	SPICSON	SPIDATIO	0x02	0x4C	0xA5	SPICSOFF
WriteTCON1	SPI	SPICSON	SPIDATOUT	0x02	0xA0	0xFF	SPICSOFF
ReadTCON1	SPI	SPICSON	SPIDATIO	0x02	0xAC	0xA5	SPICSOFF
ReadSTATUS	SPI	SPICSON	SPIDATIO	0x02	0x5C	0xA5	SPICSOFF
INCRWiper0	SPI	SPICSON	SPIDATIO	0x01	0x04	SPICSOFF	
DECRWiper0	SPI	SPICSON	SPIDATIO	0x01	0x08	SPICSOFF	

## 2.5.2 Working With the PICKit Serial Analyzer

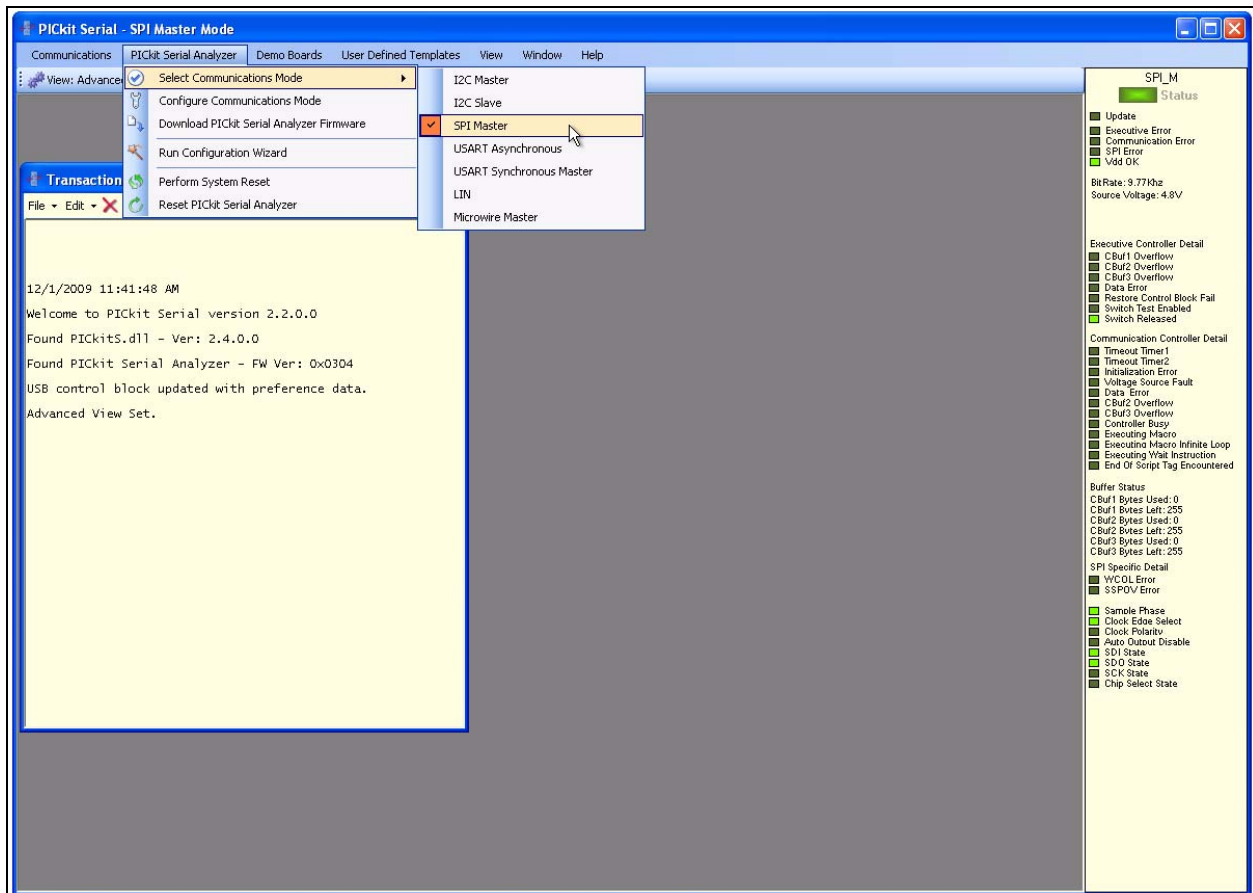
Figure 2-4 shows the PICKit Serial Window after the program has started. The Transaction window indicates if the PICKit Serial GUI located the PICKit Serial Analyzer Hardware. When starting the PICKit Serial Analyzer for the first time, some setup questions may be asked. If you have any questions, please refer to the PICKit Serial Analyzer documentation, available at [www.Microchip.com/PICKitSerial](http://www.Microchip.com/PICKitSerial).



**FIGURE 2-4:** PICKit Serial Main Window at Startup.

# Installation and Operation

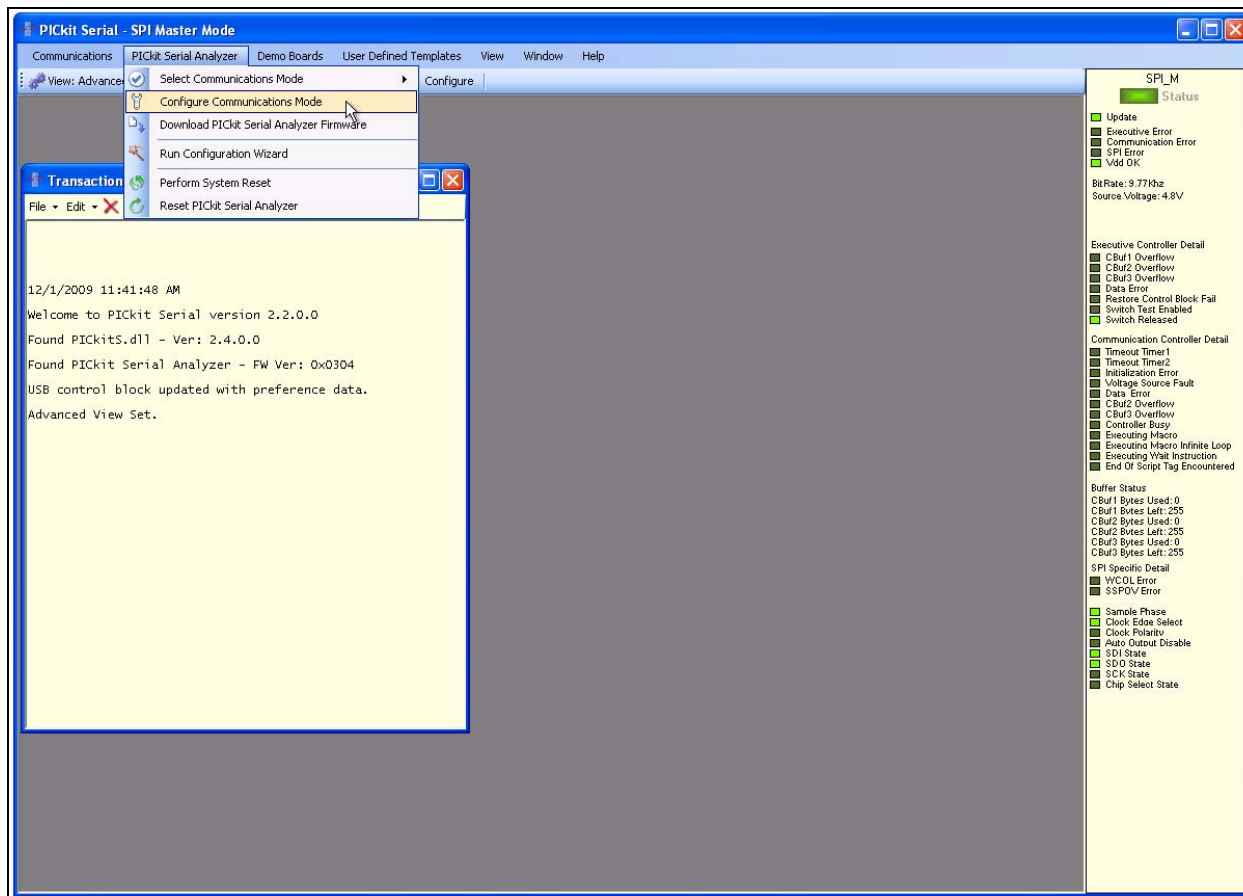
We need to select the PICkit Serial Analyzer GUI to be in SPI Master mode. Figure 2-5 shows how to select the proper mode. Select *PICkit Serial Analyzer* -> *Select Communications Mode* -> *SPI Master* menu item (make sure the SPI Master item is checked).



**FIGURE 2-5:** PICkit Serial Selecting Communications Mode.

# MCP43XXEV Evaluation Board User's Guide

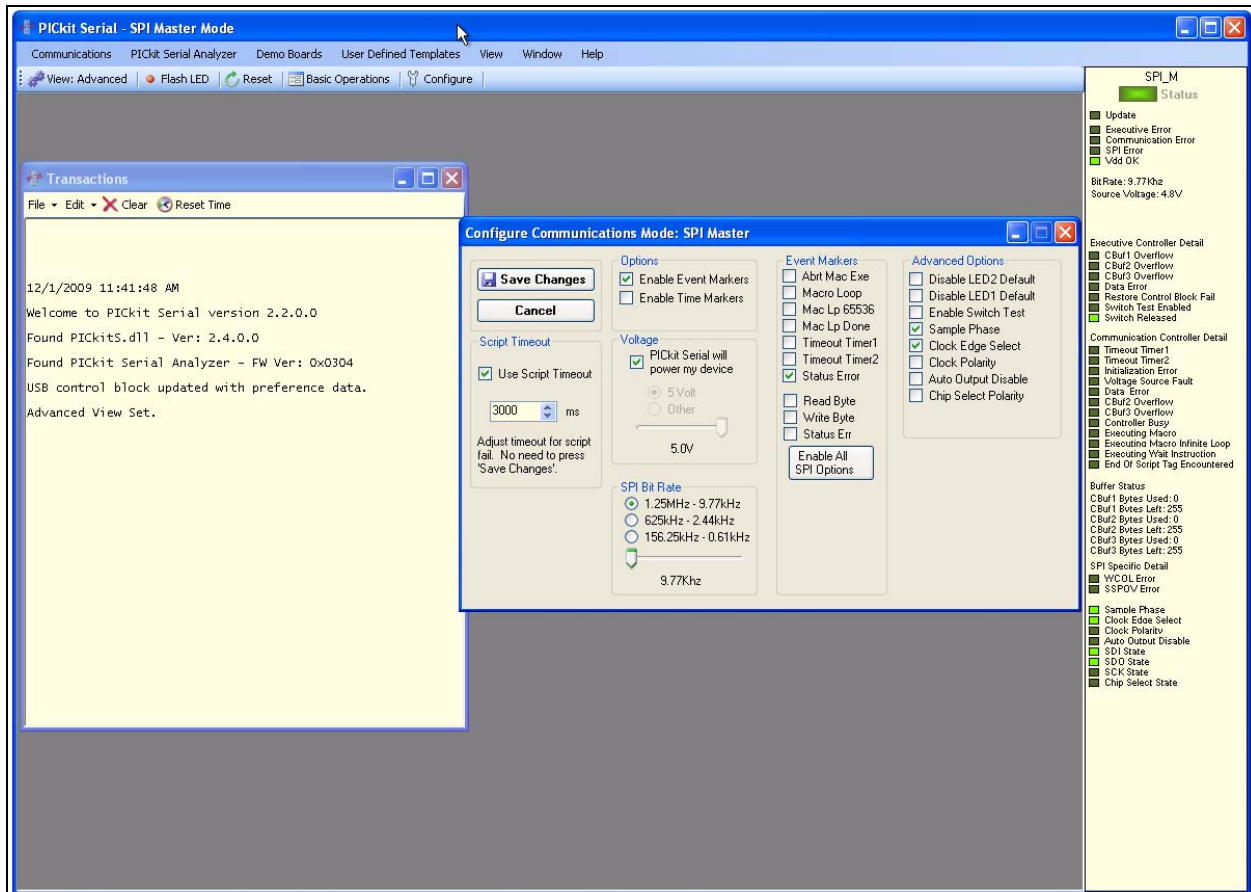
Now we need to configure the mode that we selected. Figure 2-6 shows how to configure the communications mode. Select *PICKit Serial Analyzer -> Configure Communications Mode* menu item. This will open a new window:



**FIGURE 2-6:** *PICKit Serial Main Window at Startup.*

# Installation and Operation

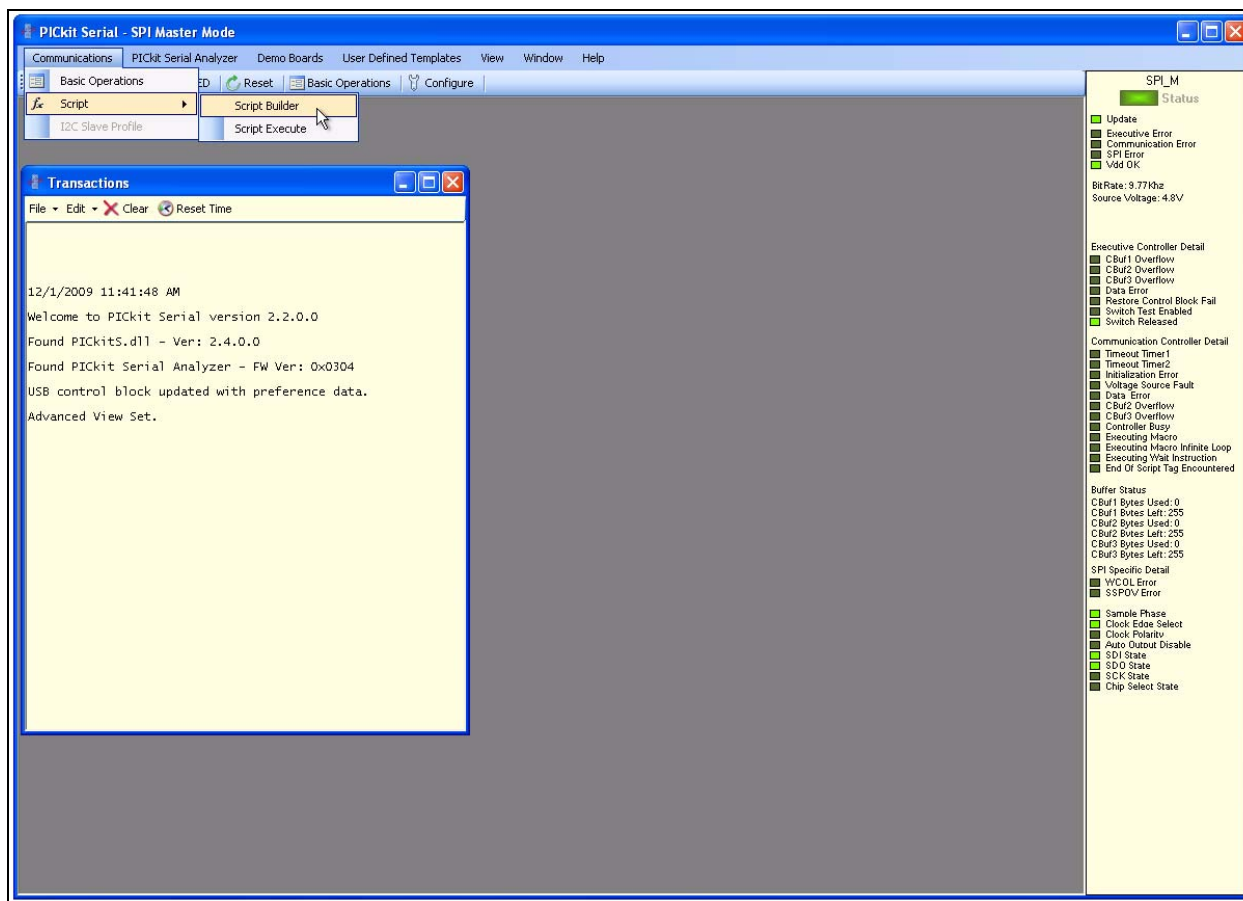
Figure 2-7 shows the Configure Communications Mode window. Ensure that your window options and settings are the same as this window, and then select the “Save Changes” button. The “Configure Communications Mode” window may now be closed.



**FIGURE 2-7:** PICkit Serial Configure Communications Mode Window.

# MCP43XXEV Evaluation Board User's Guide

Now we are going to open the Script Builder window, select the Communications -> Script -> Script Builder menu item (see Figure 2-8).

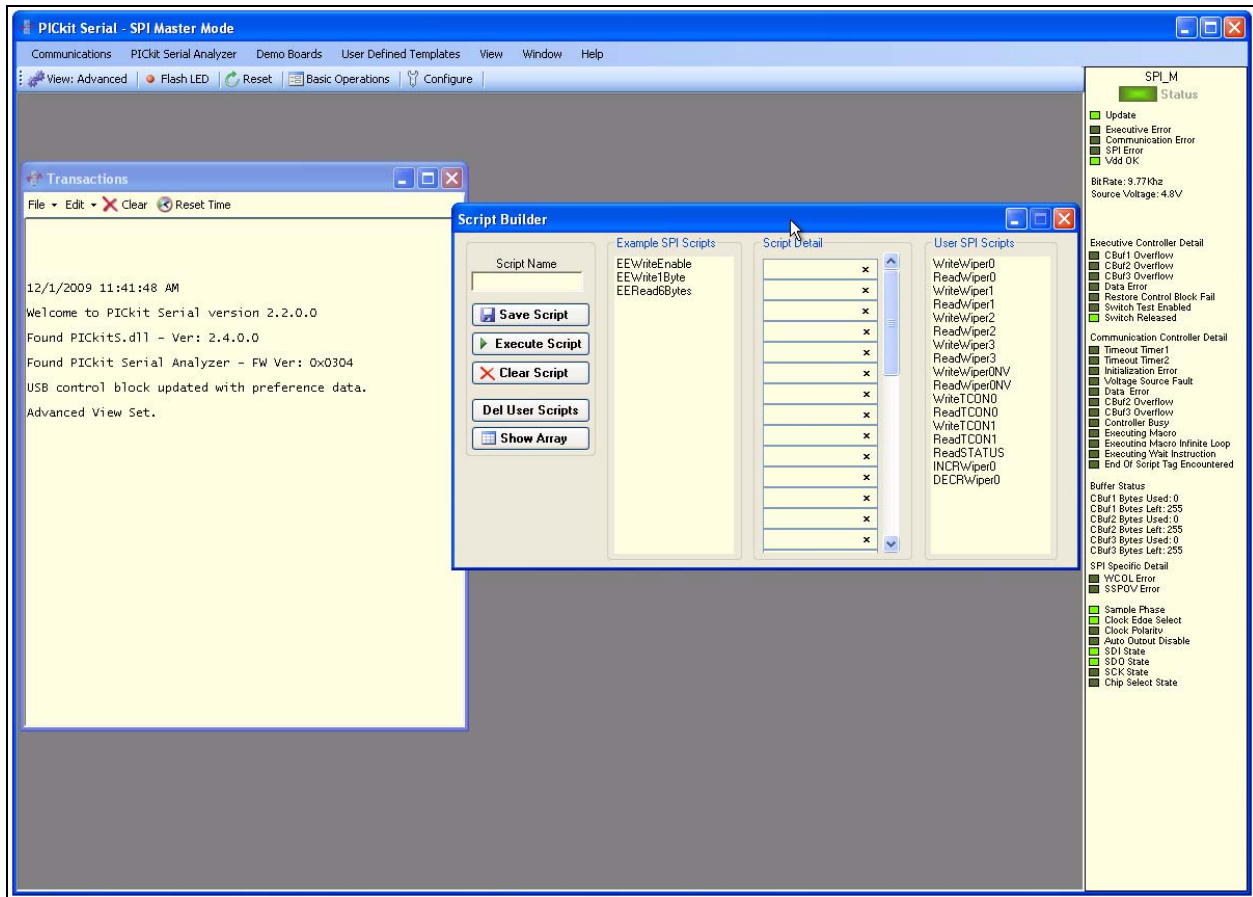


**FIGURE 2-8:** PICKit Serial - Script Builder Menu Selection.



# Installation and Operation

The Script Builder window is shown in Figure 2-9. In this window we see the User SPI Scripts including the ones that were added to the “CommScripts.txt “ file.



**FIGURE 2-9:** PICKit Serial Main Window at Startup.

# MCP43XXEV Evaluation Board User's Guide

Double clicking on the WriteWiper0 User SPI Script will load the Script Details. Figure 2-10 shows what the values mean in the Script Details. These values are hex numbers.

The first value (02h), is the number of bytes that will be written. The second byte is a data byte and contains the Device Register Address, the Device Command, and the two Most Significant bits (MSb) of the write data. The third byte is the second data byte and contains the remaining 8 bits of the write data.

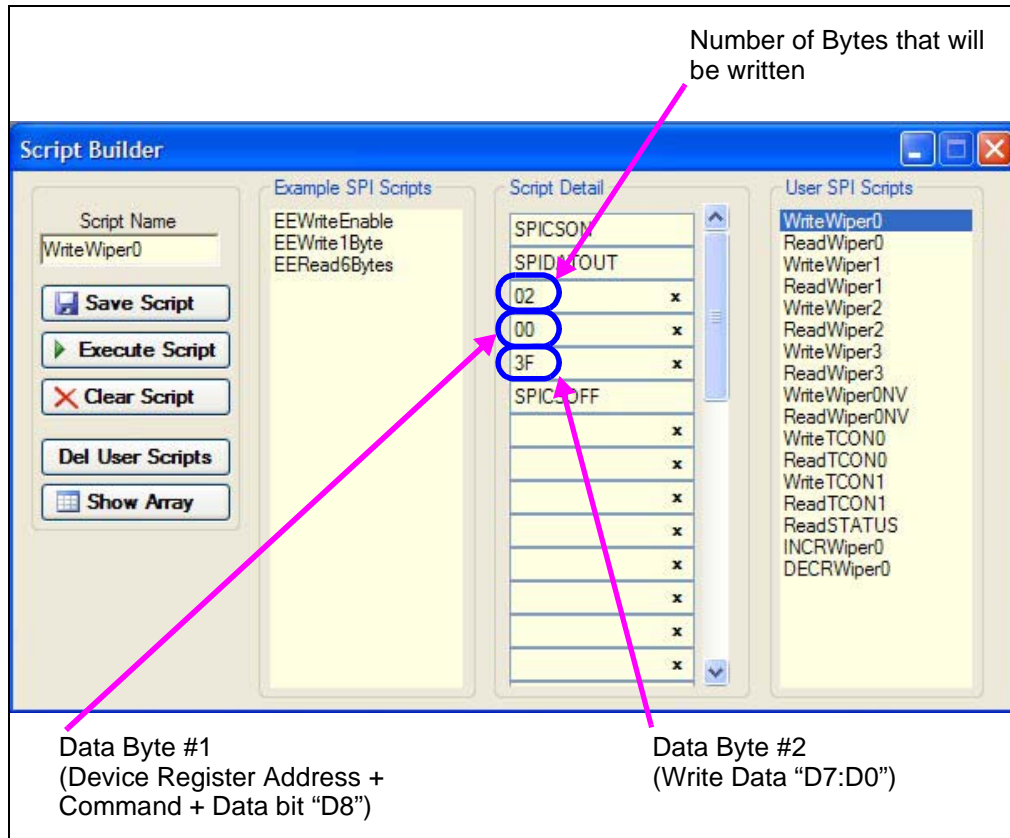


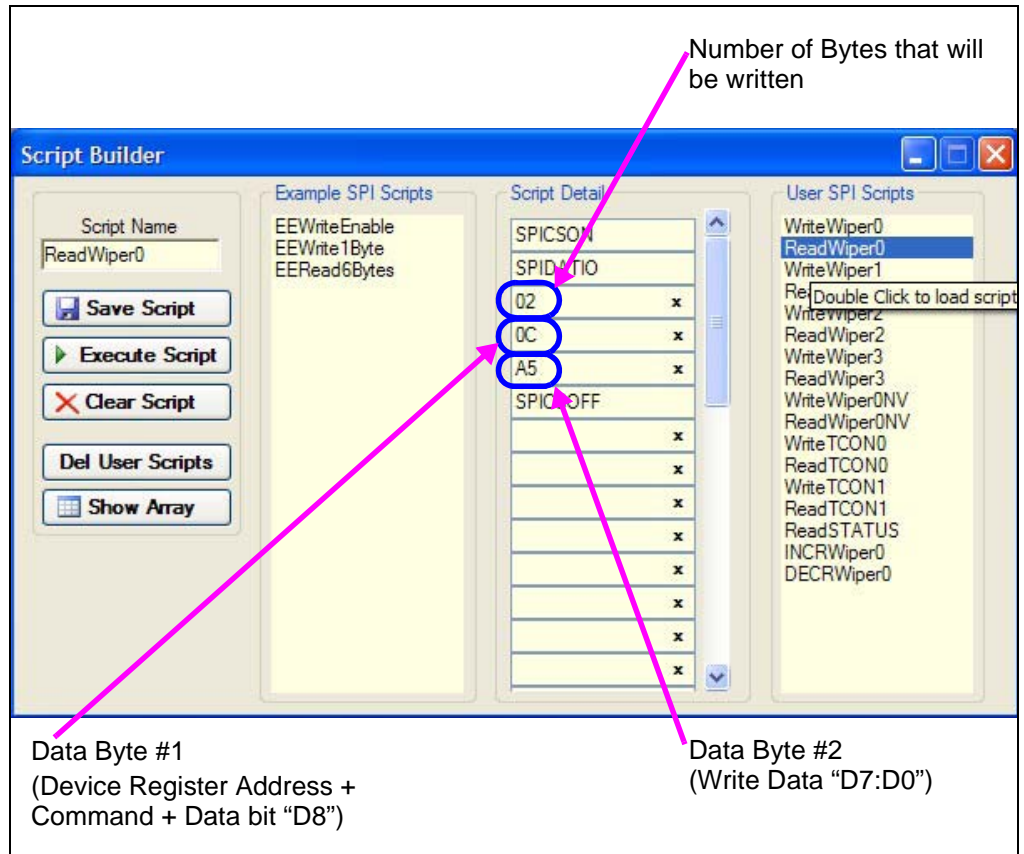
FIGURE 2-10: Example Write Script.

# Installation and Operation

Double clicking on the ReadWiper0 User SPI Script will load the Script Details. Figure 2-11 shows what the values mean in the Script Details. These values are hex numbers.

The first value (02h), is the number of bytes that will be written. The second byte is a data byte and contains the Device Register Address, the Device Command, and the two Most Significant bits (MSb) of the read data. The third byte is the second data byte and contains the remaining 8 bits of the read data.

During read commands, the value of the two LSBs of Data Byte #1 and all of the bits of Data Byte #2 are not important. The bytes are required for the SPI clock generation.



**FIGURE 2-11:** Example Read Script.

## 2.6 MCP4361 DEMO STEPS

This demo assumes that you know how to configure the PICKit Serial Analyzer for Master SPI operation. See **Section 2.5 “Configuring The PICKit Serial Analyzer”** or the PICKit Serial Analyzer User's Guide (DS51647) for additional information.

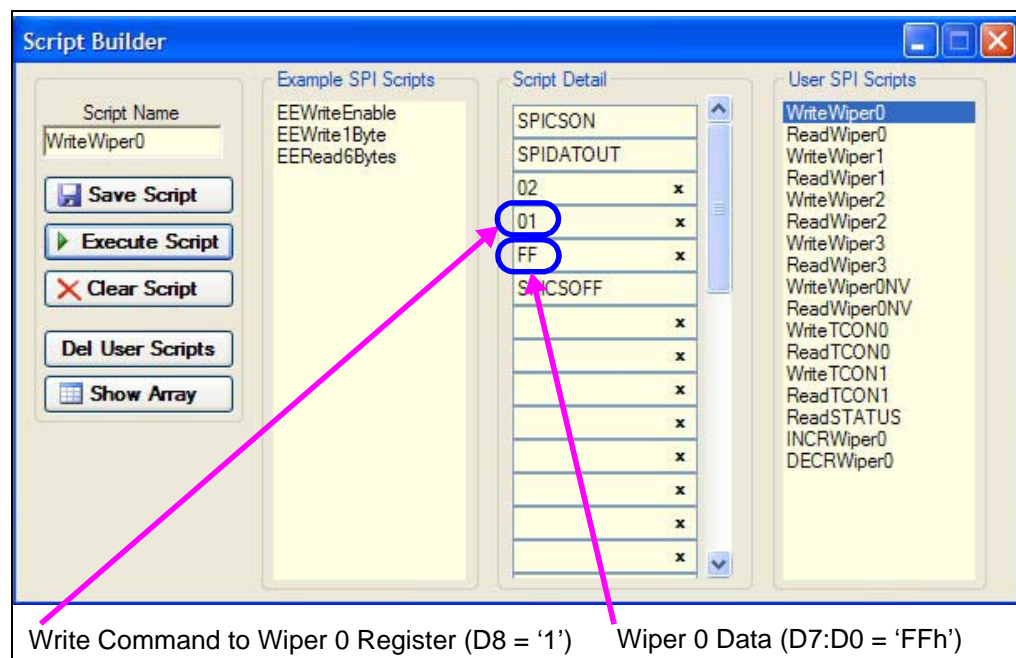
1. Plug the PICKit Serial device into the PC's USB port.
2. Plug the MCP43XXEV board into the PICKit Serial.
3. Add the User Scripts (see Example 2-1) to the “CommScripts.TXT” file.
4. Start the PICKit Serial GUI.
5. Ensure the GUI is in Master SPI communication mode (see Figure 2-5).
6. Ensure that the Master SPI configuration is appropriately configured (see Figure 2-7).
7. Measure the Wiper 0 voltage on the MCP43XXEV board (see Figure 2-2) using an oscilloscope or digital multimeter. Measure voltage from the ground plane (GND) to the Wiper (P12). The voltage on the Wiper should be  $\sim V_{DD}/2$  ( $\sim 2.5V$ ).
8. Open the Script Builder window (see Figure 2-8).
9. Double click on the “WriteWiper0” script in the “Example SPI Scripts” column. This loads the Script Detail column (see Figure 2-10).
10. Click on the **Execute Script** button. This executes the script shown in the script detail column, which will update the Wiper value to 3Fh. The Wiper voltage will now be  $\sim V_{DD}/4$  ( $\sim 1.25V$ ). The Transaction window (see Figure 2-14) will be updated to indicate the execution of the script.
11. Select the “ReadWiper0” script in the User SPI Scripts column. It should look like Figure 2-11.
12. Click on the **Execute Script** button. This executes the script shown in the script detail column. The Transaction window (see Figure 2-14) will be updated to indicate the execution of the script. The Data read is shown in the last line.
13. Double click on the “WriteWiper0” script in the “Example SPI Scripts” column. This loads the Script Detail column and modifies the Wiper 0 data to 1FFh (see Figure 2-12).
14. Click on the **Execute Script** button. This executes the script shown in the script detail column, which will update the Wiper value to 1FFh. The Wiper voltage will now be  $\sim V_{DD}$  ( $\sim 5V$ ). The Transaction window (see Figure 2-14) will be updated to indicate the execution of the script.
15. Select the “ReadWiper0” script in the User SPI Scripts column. It should look like Figure 2-11.
16. Click on the **Execute Script** button. This executes the script shown in the script detail column. The Transaction window (see Figure 2-14) will be updated to indicate the execution of the script. The Data read is shown in the last line.
17. Double click on the “WriteTCON1” script in the “Example SPI Scripts” column. This loads the Script Detail column.
18. Click on the **Execute Script** button. This executes the script shown in the script detail column. The Transaction window (see Figure 2-15) will be updated to indicate the execution of the script.
19. Select the “ReadTCON1” script in the User SPI Scripts column. It should look like Figure 2-13.
20. Click on the **Execute Script** button. This executes the script shown in the script detail column. The Transaction window (see Figure 2-15) will be updated to indicate the execution of the script. The Data read is shown in the last line.
21. In the Transaction window, click the **Clear** button.
22. On the PICKit Serial Analyzer command bar, click the **Reset** button.

# Installation and Operation

23. Select the "WriteWiper0" script in the User SPI Scripts column and then click on the **Execute Script** button.
24. Select the "ReadWiper0" script in the User SPI Scripts column and then click on the **Execute Script** button.
25. Select the "DECRWiper0" script in the User SPI Scripts column and then click on the **Execute Script** button three times.
26. Select the "ReadWiper0" script in the User SPI Scripts column and then click on the **Execute Script** button. The Transaction window shows the scripts that were executed and the current value of the Wiper 0 (see Figure 2-16).
27. In the Transaction window, click the **Clear** button.
28. On the PICkit Serial Analyzer command bar, click the **Reset** button.
29. Select the "WriteWiper0" script in the User SPI Scripts column and then click on the **Execute Script** button.
30. Select the "ReadWiper0" script in the User SPI Scripts column and then click on the **Execute Script** button.
31. Select the "INCRWiper0" script in the User SPI Scripts column and then click on the **Execute Script** button three times.
32. Select the "ReadWiper0" script in the User SPI Scripts column and then click on the **Execute Script** button. The Transaction window shows the scripts that were executed and the current value of the Wiper 0 (see Figure 2-17).
33. You can repeat the sequence of writing values to the Wiper register, or by Writing then Reading the values back.

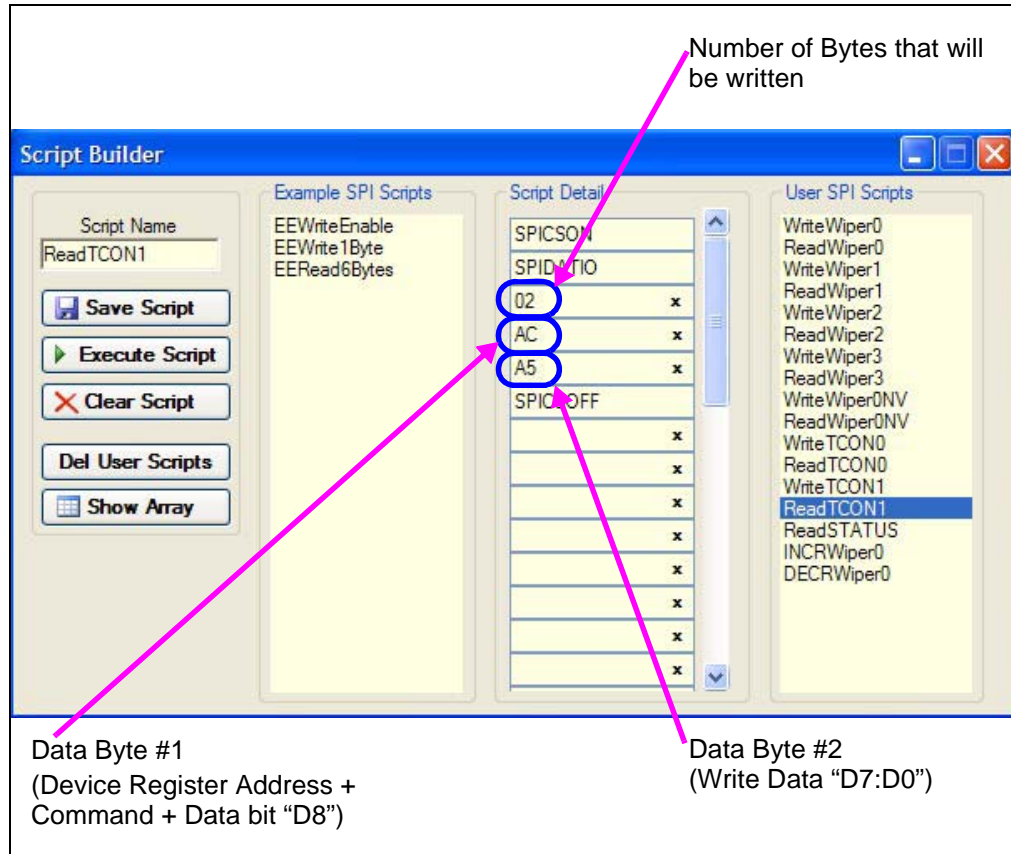
## NOTICE

If at any time during script execution, an error message is generated in the transaction window, it is good practice to reset the PICkit Serial Analyzer (PKSA). The PKSA can be reset using the "Reset" toolbar icon. Verify that subsequent script operations do not generate errors.

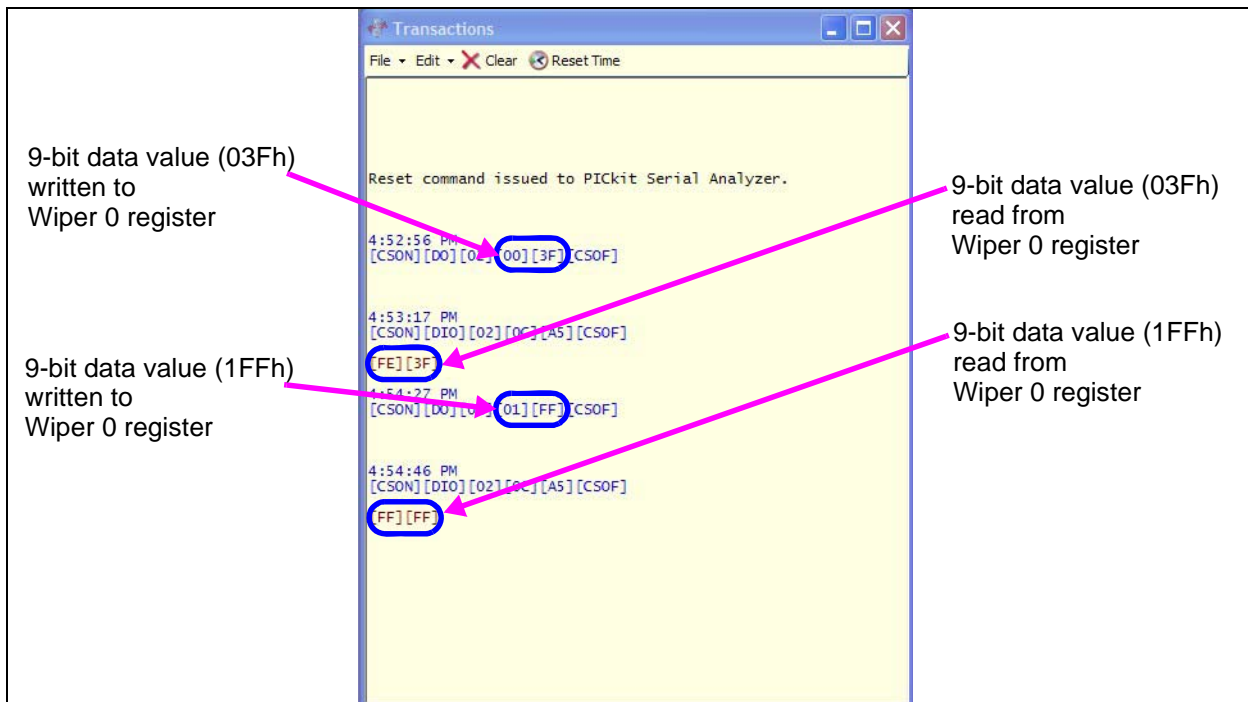


**FIGURE 2-12:** MCP43XX Write Wiper 0 Script File - Updating Wiper Value.

# MCP43XXEV Evaluation Board User's Guide

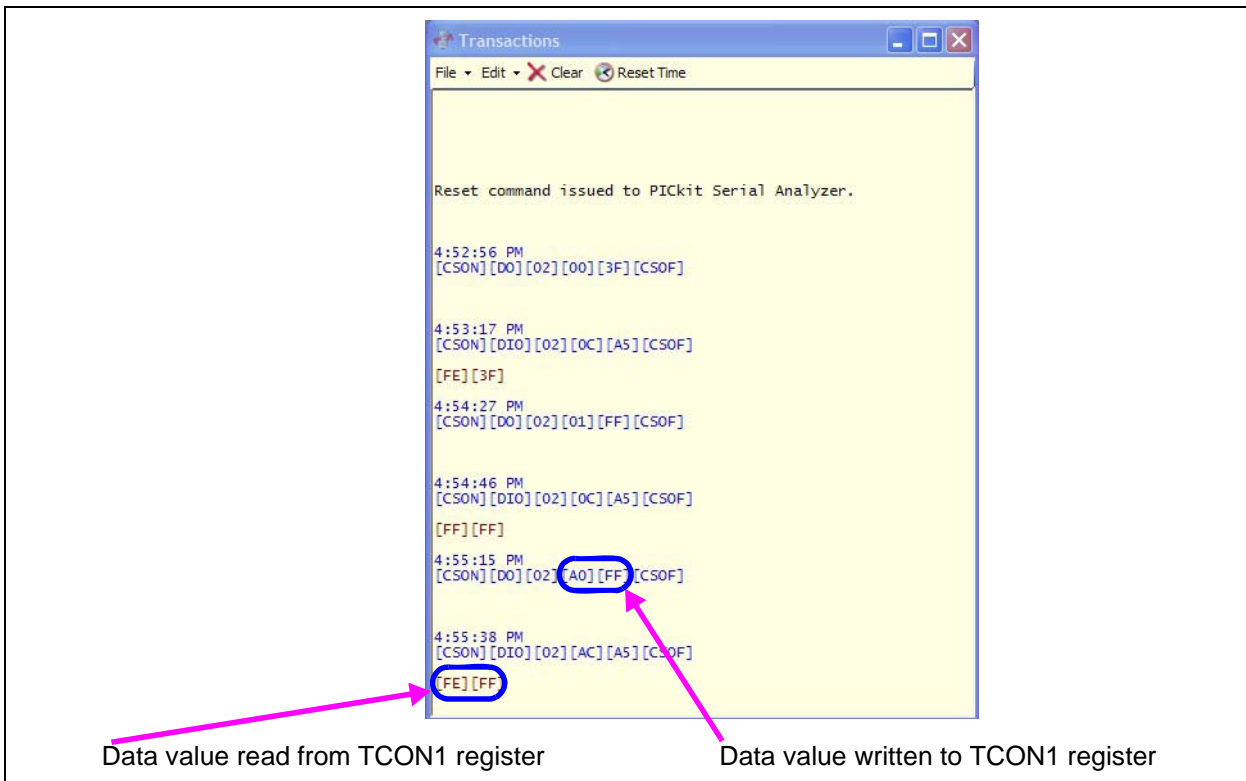


**FIGURE 2-13:** MCP43XX Read TCON1 Script.

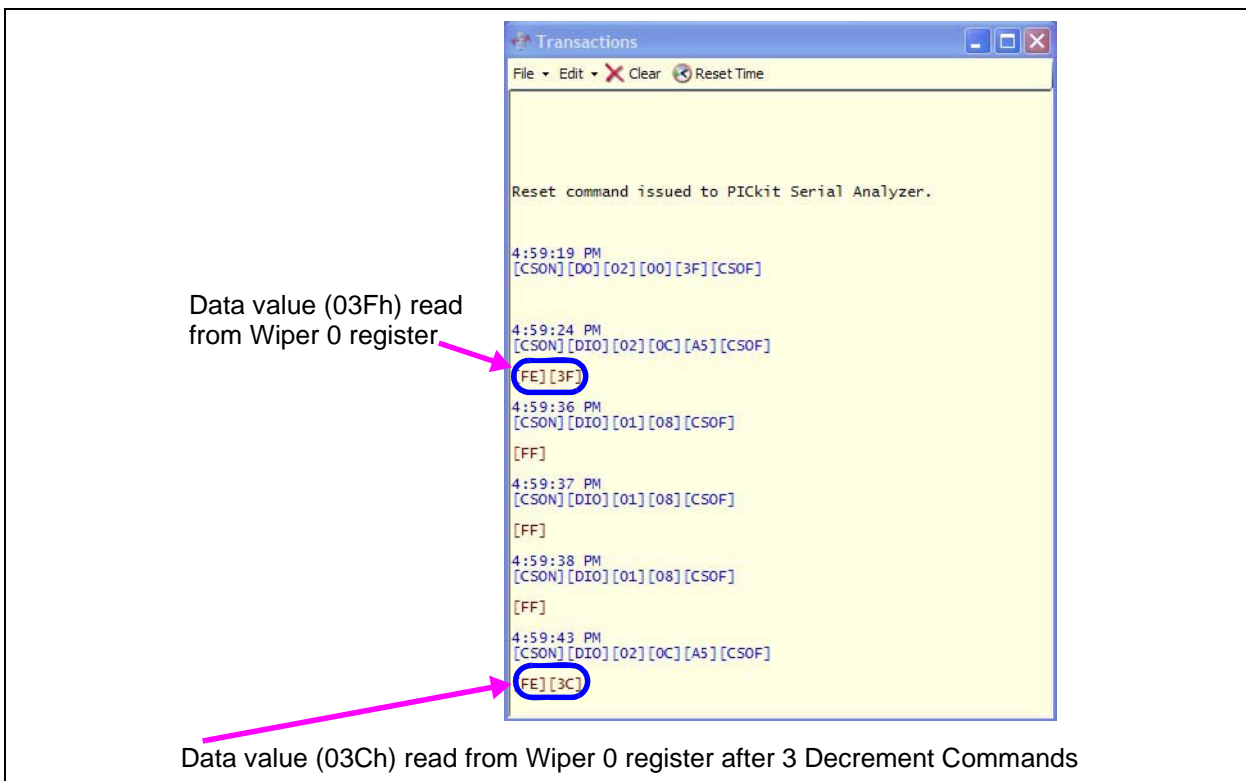


**FIGURE 2-14:** MCP4361 Transaction Window - Wiper 0 Writes and Reads.

# Installation and Operation

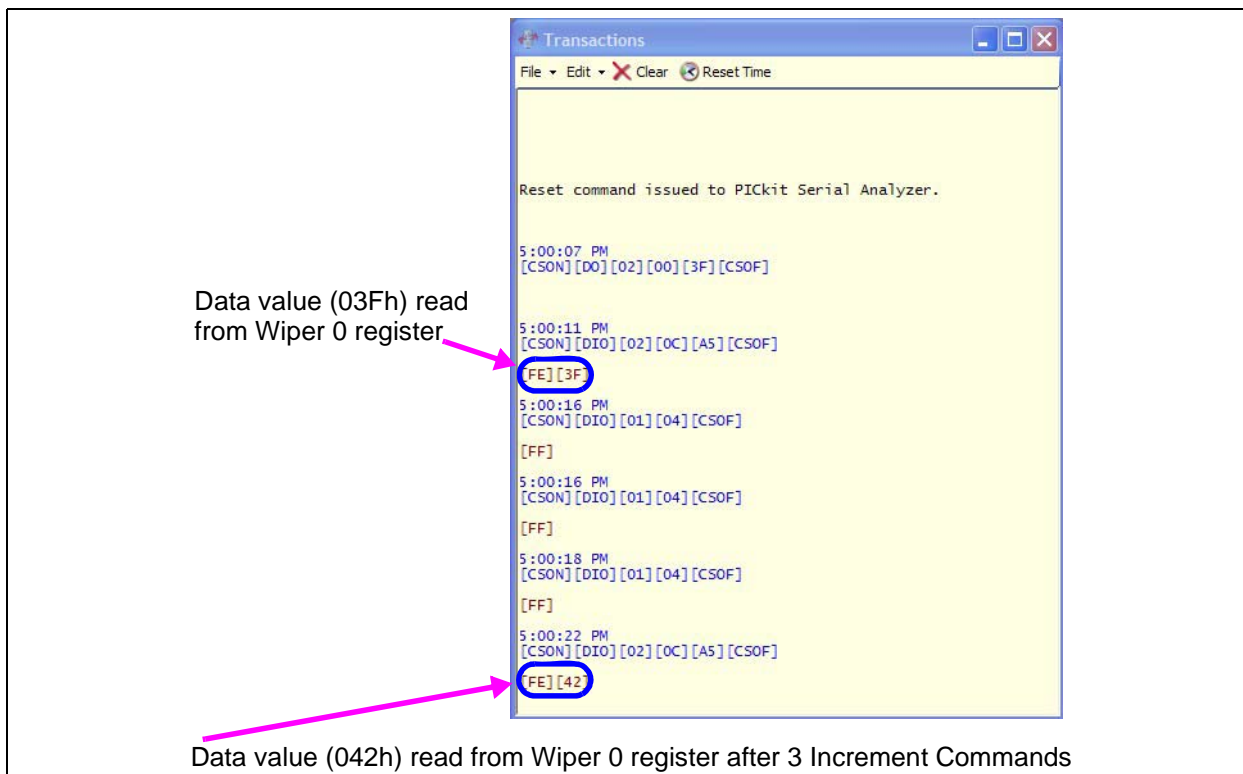


**FIGURE 2-15:** MCP4361 Transaction Window - TCON1 Writes and Reads.



**FIGURE 2-16:** MCP4361 Transaction Window - Wiper 0 Decrements.





**FIGURE 2-17:** MCP4361 Transaction Window - Wiper 0 Increments.

## 2.6.1 The TSSOP20EV PCB and Supported Digital Potentiometers

Table 2-4 shows the current Digital Potentiometers that are supported by the TSSOP20EV PCB.

**TABLE 2-4: TSSOP20EV PCB SUPPORTED DIGITAL POTENTIOMETERS**

Device	TSSOP-20	TSSOP-14	Comment
MCP4231	—	Yes	Dual Pot, SPI Interface
MCP4241	—	Yes	Dual Pot, SPI Interface
MCP4251	—	Yes	Dual Pot, SPI Interface
MCP4261	—	Yes	Dual Pot, SPI Interface
MCP4331	Yes	—	Quad Pot, SPI Interface
MCP4341	Yes	—	Quad Pot, SPI Interface
MCP4351	Yes	—	Quad Pot, SPI Interface
MCP4361	Yes	—	Quad Pot, SPI Interface
MCP4631	—	Yes	Dual Pot, I <sup>2</sup> C Interface
MCP4641	—	Yes	Dual Pot, I <sup>2</sup> C Interface
MCP4651	—	Yes	Dual Pot, I <sup>2</sup> C Interface
MCP4661	—	Yes	Dual Pot, I <sup>2</sup> C Interface
MCP42010	—	Yes	Dual Pot, SPI Interface
MCP42050	—	Yes	Dual Pot, SPI Interface
MCP42100	—	Yes	Dual Pot, SPI Interface



---

---

## Appendix A. Schematic and Layouts

---

---

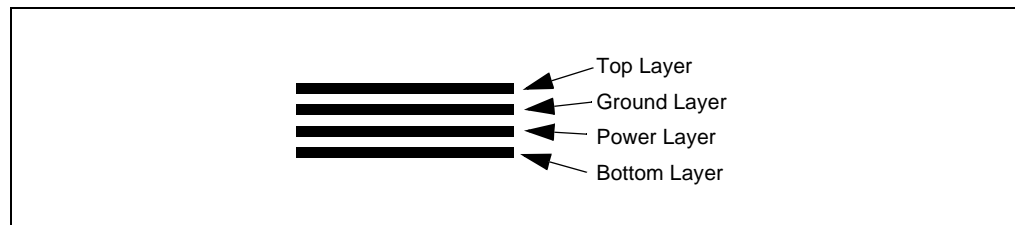
### A.1 INTRODUCTION

This appendix contains the schematics and layouts for the MCP43XXEV Evaluation Board. Diagrams included in this appendix:

- Board – Schematic
- Board – Top Trace, Silk and Pads
- Board – Bottom Trace and Pads
- Board – Layer 2 Ground Plane
- Board – Layer 3 Power Plane
- Board Layout – Top Components
- Board – Bottom Silk, Trace and Pads

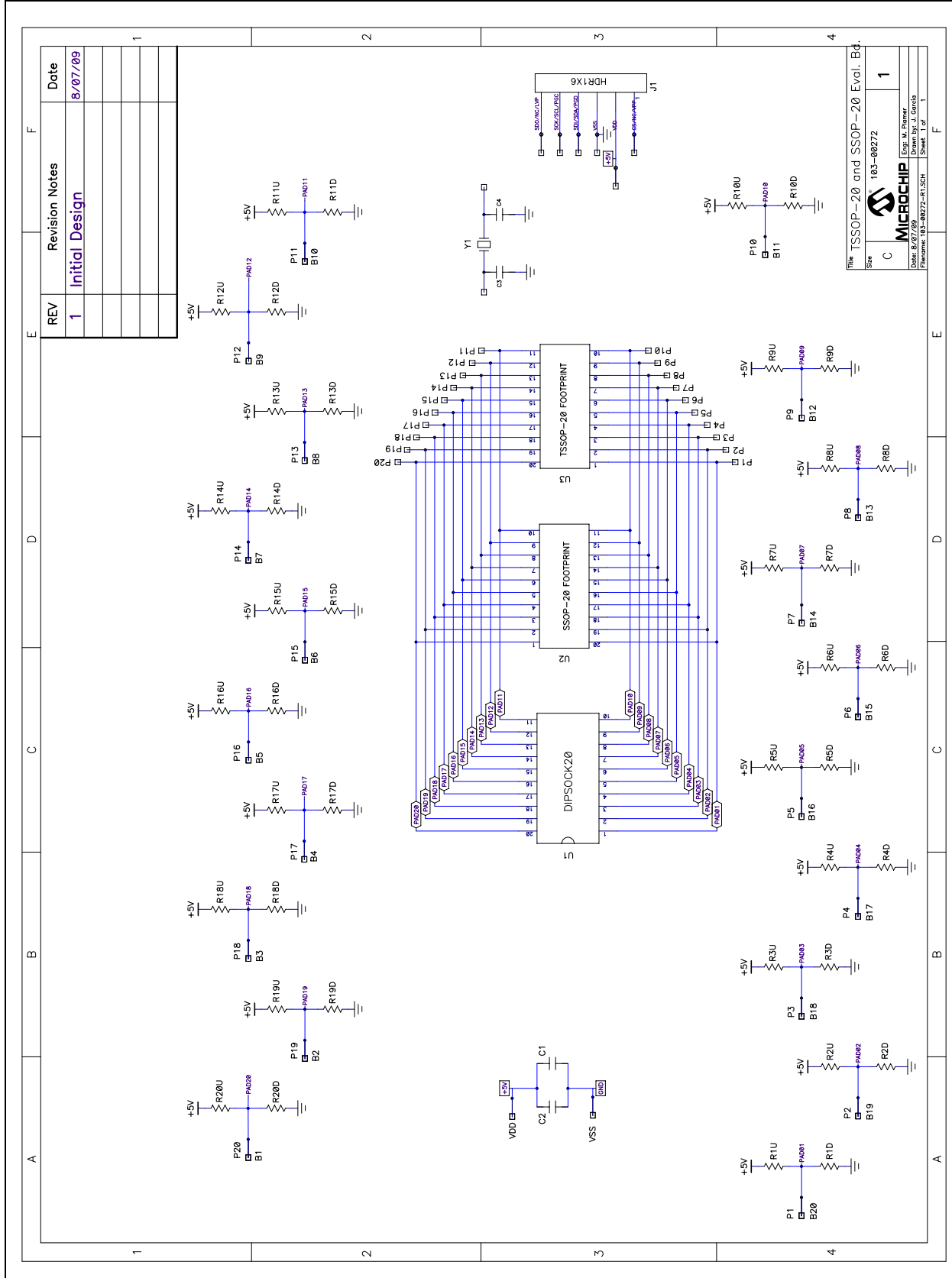
### A.2 SCHEMATICS AND PCB LAYOUT

Board – Schematic shows the schematic of the MCP43XXEV Evaluation Board. The layer order is shown in Figure A-1.

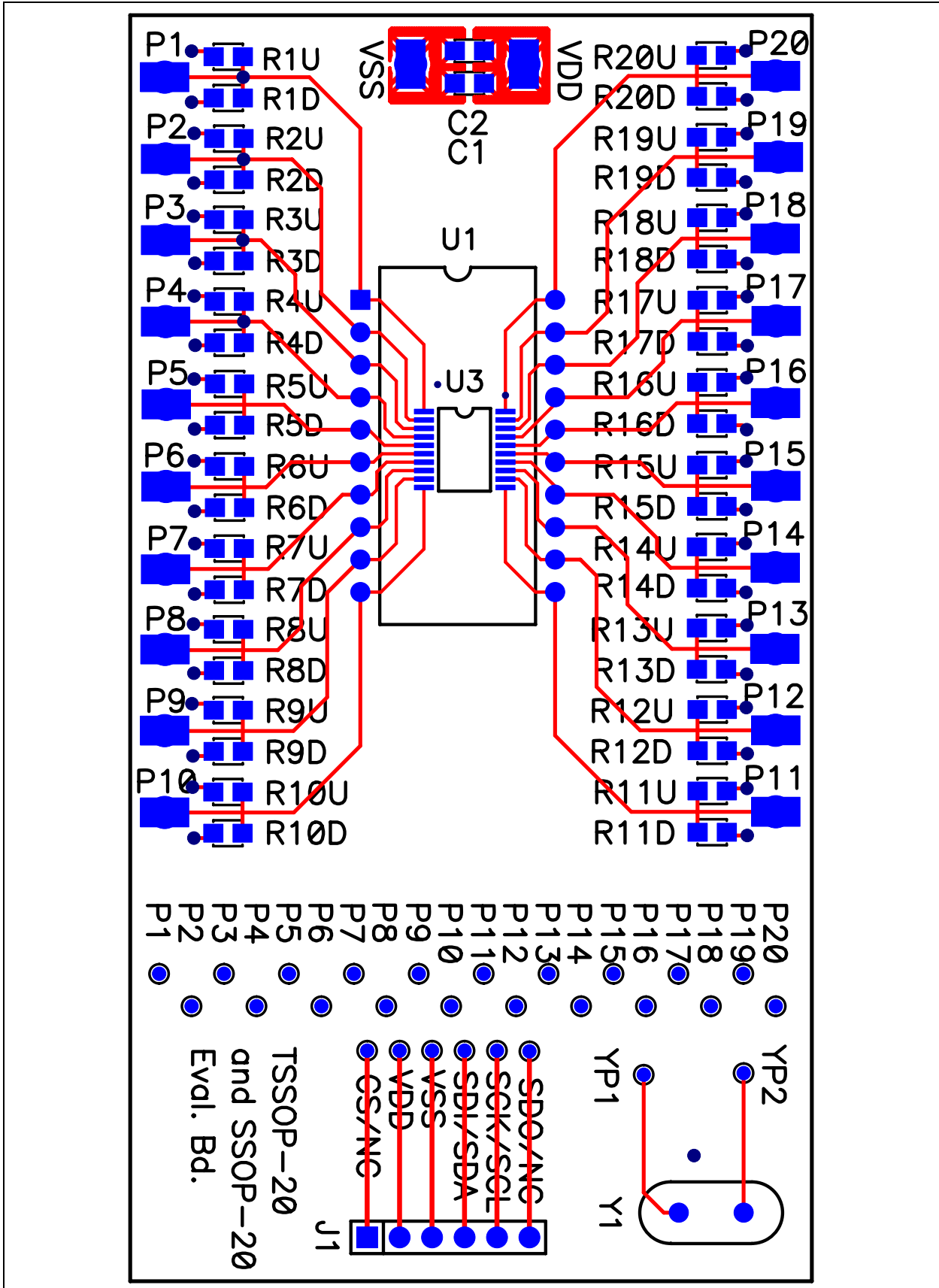


**FIGURE A-1:** *Layer Order.*

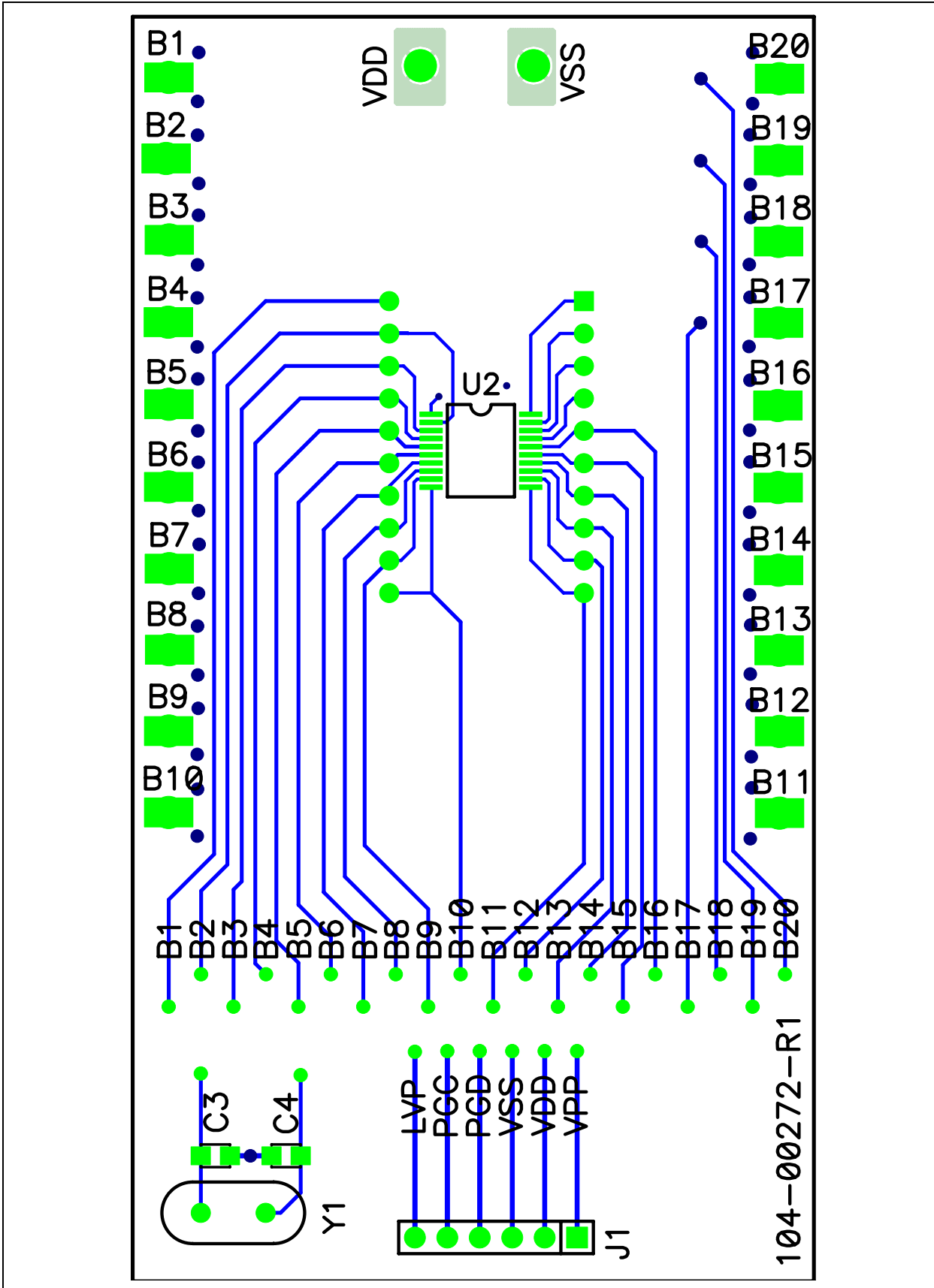
## A.3 BOARD – SCHEMATIC



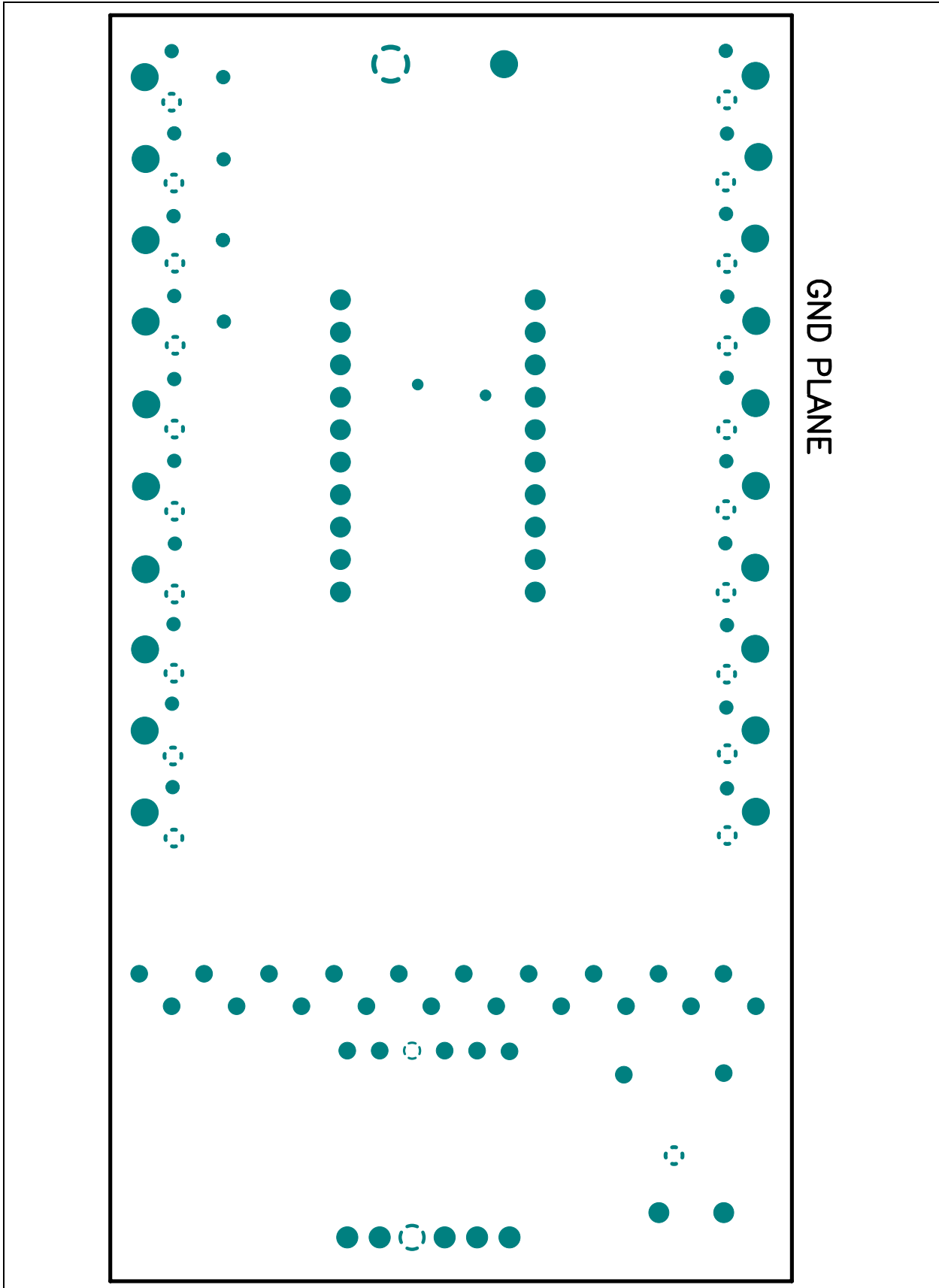
## A.4 BOARD – TOP TRACE, SILK AND PADS



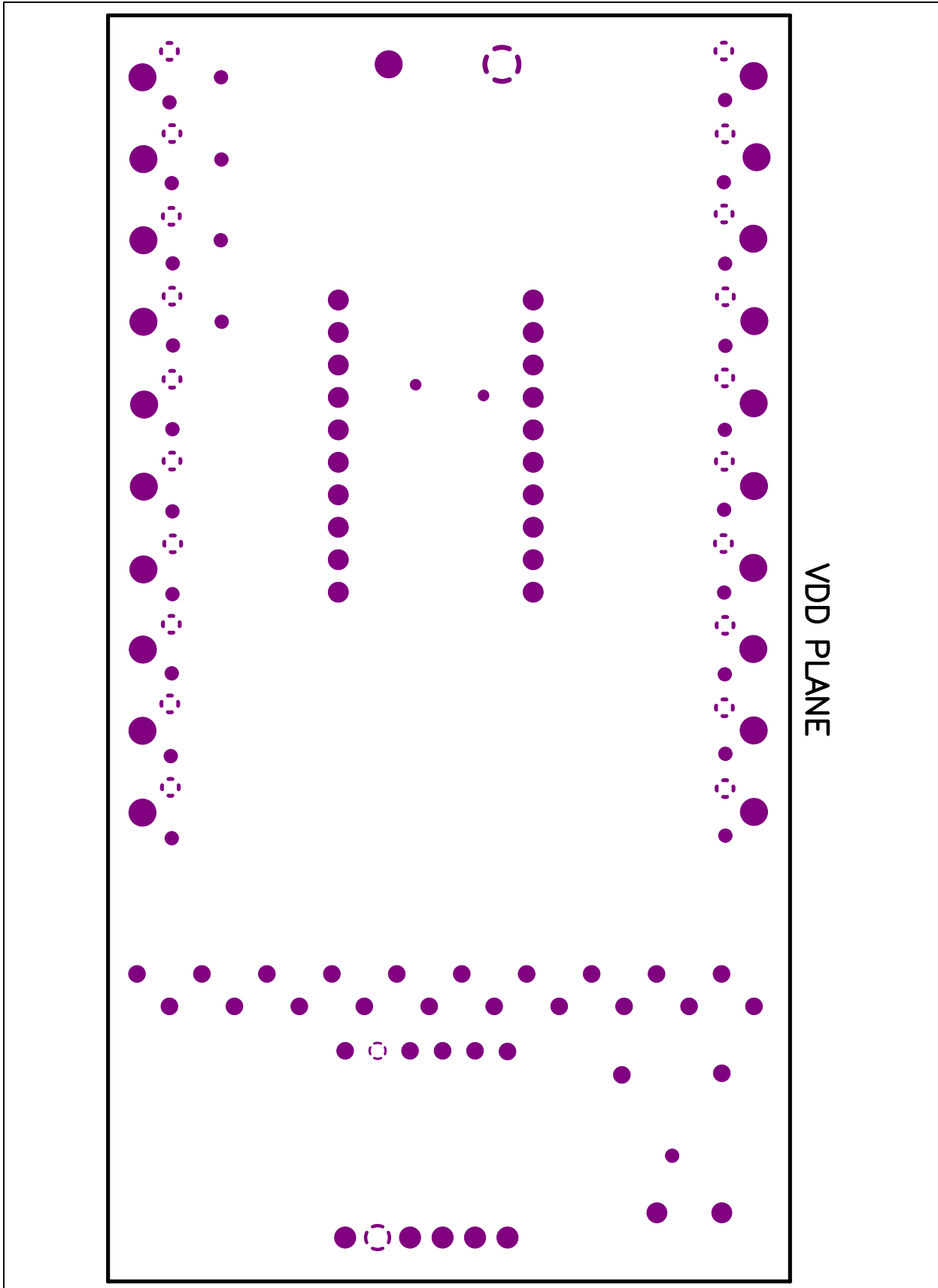
A.5 BOARD – BOTTOM TRACE AND PADS



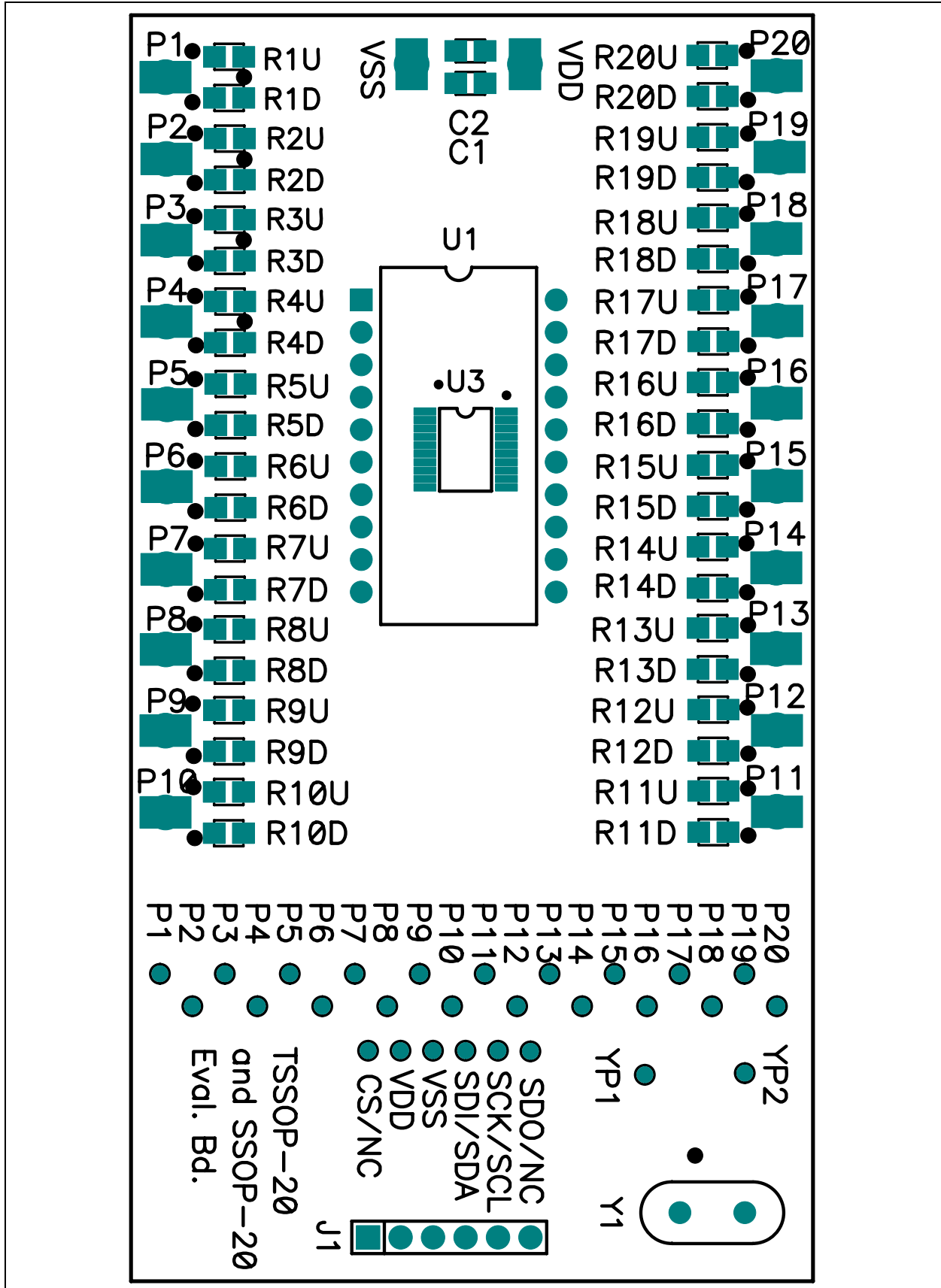
## A.6 BOARD – LAYER 2 GROUND PLANE



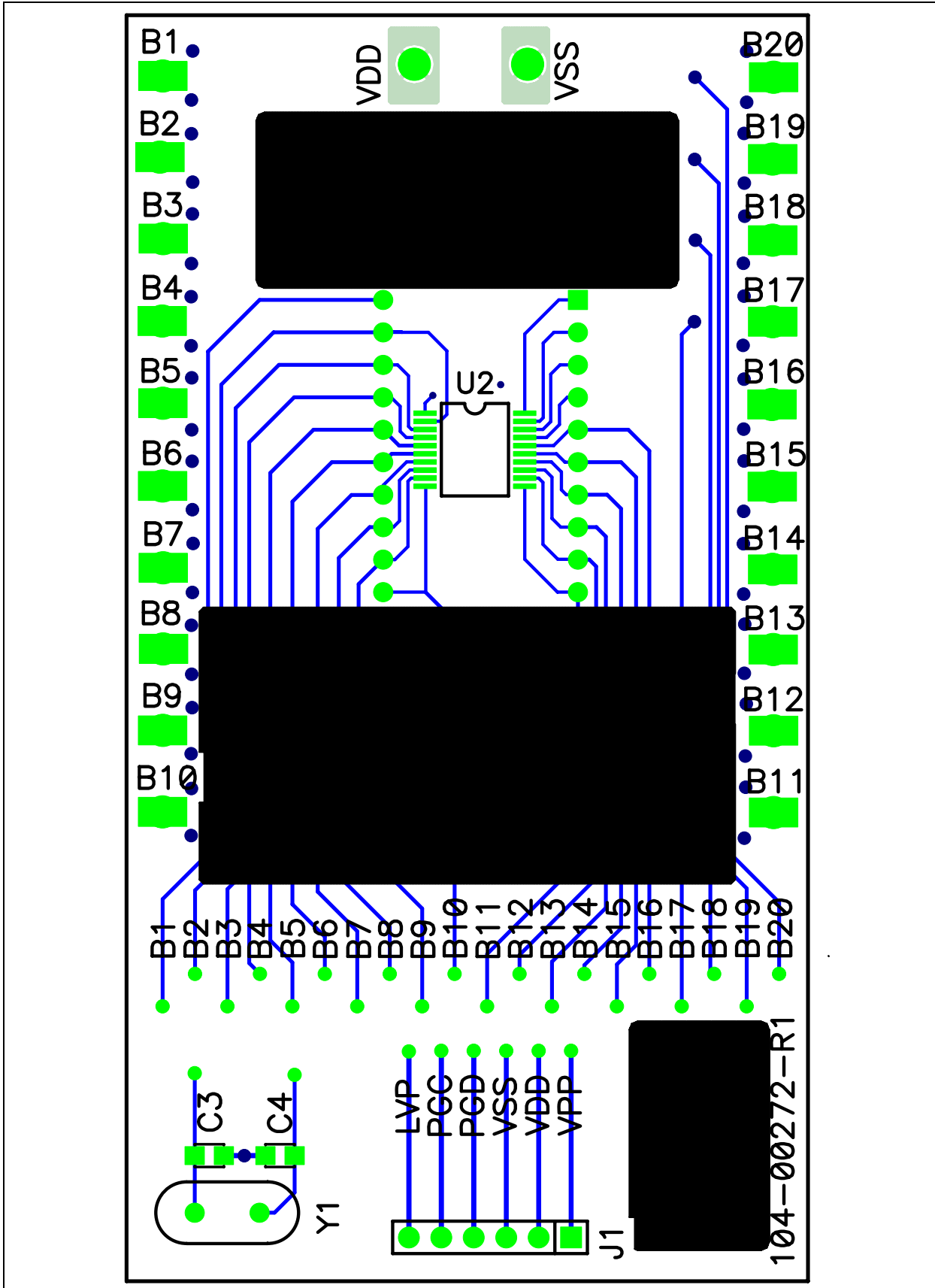
## A.7 BOARD – LAYER 3 POWER PLANE



## A.8 BOARD LAYOUT – TOP COMPONENTS



A.9 BOARD – BOTTOM SILK, TRACE AND PADS







# MCP43XXEV EVALUATION BOARD USER'S GUIDE

## Appendix B. Bill of Materials (BOM)

**TABLE B-1: BILL OF MATERIALS**

Qty	Reference	Description	Manufacturer	Part Number
1	PCB	<b>Note 1</b>	Microchip Technology Inc.	104-00272
8	R1U, R3D, R7D R8D, R10U, R17U R15U, R14U	RES 0.0 OHM 1/8W 5% 0805 SMD	Panasonic® - ECG	ERJ-6GEY0R00V
2	R14U, R15U	RES 10.0K OHM 1/8W 1% 0805 SMD	Panasonic - ECG	ERJ-6ENF1002V
1	U3	MCP4361 Quad SPI Digi-Pot (10K Ohm version )	Microchip Technology Inc.	MCP4361-103E/ST
4	P2, P9, P12, P19	TEST POINT PC MULTI PURPOSE ORG	Keystone Electronics®	5013
1	J1	CONN HEADER 6POS .100 R/A GOLD	Molex/Waldom Electronics Corp.	22-28-8062

**Note 1:** This assembly uses RoHS Compliant TSSOP-20 to DIP-20 Evaluation Board.

**2:** The components listed in this Bill of Materials are representative of the PCB assembly. The released BOM used in manufacturing uses all RoHS-compliant components.



## WORLDWIDE SALES AND SERVICE

### AMERICAS

**Corporate Office**  
2355 West Chandler Blvd.  
Chandler, AZ 85224-6199  
Tel: 480-792-7200  
Fax: 480-792-7277  
Technical Support:  
<http://support.microchip.com>  
Web Address:  
[www.microchip.com](http://www.microchip.com)

**Atlanta**  
Duluth, GA  
Tel: 678-957-9614  
Fax: 678-957-1455

**Boston**  
Westborough, MA  
Tel: 774-760-0087  
Fax: 774-760-0088

**Chicago**  
Itasca, IL  
Tel: 630-285-0071  
Fax: 630-285-0075

**Cleveland**  
Independence, OH  
Tel: 216-447-0464  
Fax: 216-447-0643

**Dallas**  
Addison, TX  
Tel: 972-818-7423  
Fax: 972-818-2924

**Detroit**  
Farmington Hills, MI  
Tel: 248-538-2250  
Fax: 248-538-2260

**Kokomo**  
Kokomo, IN  
Tel: 765-864-8360  
Fax: 765-864-8387

**Los Angeles**  
Mission Viejo, CA  
Tel: 949-462-9523  
Fax: 949-462-9608

**Santa Clara**  
Santa Clara, CA  
Tel: 408-961-6444  
Fax: 408-961-6445

**Toronto**  
Mississauga, Ontario,  
Canada  
Tel: 905-673-0699  
Fax: 905-673-6509

### ASIA/PACIFIC

**Asia Pacific Office**  
Suites 3707-14, 37th Floor  
Tower 6, The Gateway  
Harbour City, Kowloon  
Hong Kong  
Tel: 852-2401-1200  
Fax: 852-2401-3431

**Australia - Sydney**  
Tel: 61-2-9868-6733  
Fax: 61-2-9868-6755

**China - Beijing**  
Tel: 86-10-8528-2100  
Fax: 86-10-8528-2104

**China - Chengdu**  
Tel: 86-28-8665-5511  
Fax: 86-28-8665-7889

**China - Chongqing**  
Tel: 86-23-8980-9588  
Fax: 86-23-8980-9500

**China - Hong Kong SAR**  
Tel: 852-2401-1200  
Fax: 852-2401-3431

**China - Nanjing**  
Tel: 86-25-8473-2460  
Fax: 86-25-8473-2470

**China - Qingdao**  
Tel: 86-532-8502-7355  
Fax: 86-532-8502-7205

**China - Shanghai**  
Tel: 86-21-5407-5533  
Fax: 86-21-5407-5066

**China - Shenyang**  
Tel: 86-24-2334-2829  
Fax: 86-24-2334-2393

**China - Shenzhen**  
Tel: 86-755-8203-2660  
Fax: 86-755-8203-1760

**China - Wuhan**  
Tel: 86-27-5980-5300  
Fax: 86-27-5980-5118

**China - Xian**  
Tel: 86-29-8833-7252  
Fax: 86-29-8833-7256

**China - Xiamen**  
Tel: 86-592-2388138  
Fax: 86-592-2388130

**China - Zhuhai**  
Tel: 86-756-3210040  
Fax: 86-756-3210049

### ASIA/PACIFIC

**India - Bangalore**  
Tel: 91-80-3090-4444  
Fax: 91-80-3090-4123

**India - New Delhi**  
Tel: 91-11-4160-8631  
Fax: 91-11-4160-8632

**India - Pune**  
Tel: 91-20-2566-1512  
Fax: 91-20-2566-1513

**Japan - Yokohama**  
Tel: 81-45-471- 6166  
Fax: 81-45-471-6122

**Korea - Daegu**  
Tel: 82-53-744-4301  
Fax: 82-53-744-4302

**Korea - Seoul**  
Tel: 82-2-554-7200  
Fax: 82-2-558-5932 or  
82-2-558-5934

**Malaysia - Kuala Lumpur**  
Tel: 60-3-6201-9857  
Fax: 60-3-6201-9859

**Malaysia - Penang**  
Tel: 60-4-227-8870  
Fax: 60-4-227-4068

**Philippines - Manila**  
Tel: 63-2-634-9065  
Fax: 63-2-634-9069

**Singapore**  
Tel: 65-6334-8870  
Fax: 65-6334-8850

**Taiwan - Hsin Chu**  
Tel: 886-3-6578-300  
Fax: 886-3-6578-370

**Taiwan - Kaohsiung**  
Tel: 886-7-213-7830  
Fax: 886-7-330-9305

**Taiwan - Taipei**  
Tel: 886-2-2500-6610  
Fax: 886-2-2508-0102

**Thailand - Bangkok**  
Tel: 66-2-694-1351  
Fax: 66-2-694-1350

### EUROPE

**Austria - Wels**  
Tel: 43-7242-2244-39  
Fax: 43-7242-2244-393

**Denmark - Copenhagen**  
Tel: 45-4450-2828  
Fax: 45-4485-2829

**France - Paris**  
Tel: 33-1-69-53-63-20  
Fax: 33-1-69-30-90-79

**Germany - Munich**  
Tel: 49-89-627-144-0  
Fax: 49-89-627-144-44

**Italy - Milan**  
Tel: 39-0331-742611  
Fax: 39-0331-466781

**Netherlands - Drunen**  
Tel: 31-416-690399  
Fax: 31-416-690340

**Spain - Madrid**  
Tel: 34-91-708-08-90  
Fax: 34-91-708-08-91

**UK - Wokingham**  
Tel: 44-118-921-5869  
Fax: 44-118-921-5820

07/15/10



## Стандарт Электрон Связь

Мы молодая и активно развивающаяся компания в области поставок электронных компонентов. Мы поставляем электронные компоненты отечественного и импортного производства напрямую от производителей и с крупнейших складов мира.

Благодаря сотрудничеству с мировыми поставщиками мы осуществляем комплексные и плановые поставки широчайшего спектра электронных компонентов.

Собственная эффективная логистика и склад в обеспечивает надежную поставку продукции в точно указанные сроки по всей России.

Мы осуществляем техническую поддержку нашим клиентам и предпродажную проверку качества продукции. На все поставляемые продукты мы предоставляем гарантию .

Осуществляем поставки продукции под контролем ВП МО РФ на предприятия военно-промышленного комплекса России , а также работаем в рамках 275 ФЗ с открытием отдельных счетов в уполномоченном банке. Система менеджмента качества компании соответствует требованиям ГОСТ ISO 9001.

Минимальные сроки поставки, гибкие цены, неограниченный ассортимент и индивидуальный подход к клиентам являются основой для выстраивания долгосрочного и эффективного сотрудничества с предприятиями радиоэлектронной промышленности, предприятиями ВПК и научно-исследовательскими институтами России.

С нами вы становитесь еще успешнее!

### Наши контакты:

**Телефон:** +7 812 627 14 35

**Электронная почта:** [sales@st-electron.ru](mailto:sales@st-electron.ru)

**Адрес:** 198099, Санкт-Петербург,  
Промышленная ул, дом № 19, литера Н,  
помещение 100-Н Офис 331