

PTRA082808NF

Thermally-Enhanced High Power RF LDMOS FET 280 W, 48 V, 790 – 820 MHz

Description

The PTRA082808NF is a 280-watt LDMOS FET intended for use in multi-standard cellular power amplifier applications in the 790 to 820 MHz frequency band. Features include input and output matching, high gain and thermally-enhanced package with earless flanges. Manufactured with Wolfspeed's advanced LDMOS process, this device provides excellent thermal performance and superior reliability.



PTRA082808NF
Package PG-HBSOF-6-2

Features

- Broadband internal input and output matching
- Asymmetrical design
 - Main : $P_{1dB} = 115\text{ W Typ}$
 - Peak : $P_{1dB} = 165\text{ W Typ}$
- Typical Pulsed CW performance, 820 MHz, 48 V, Doherty configuration
 - Output power at $P_{3dB} = 250\text{ W}$
 - Efficiency = 55.6 %
 - Gain = 16.2 dB
- Capable of handling 10:1 VSWR @ 48 V, 56.2 W (CW) output power
- Human Body Model Class 1C (per ANSI/ESDA/ JEDEC JS-001)
- Integrated ESD protection
- Low thermal resistance
- Pb-free and RoHS compliant

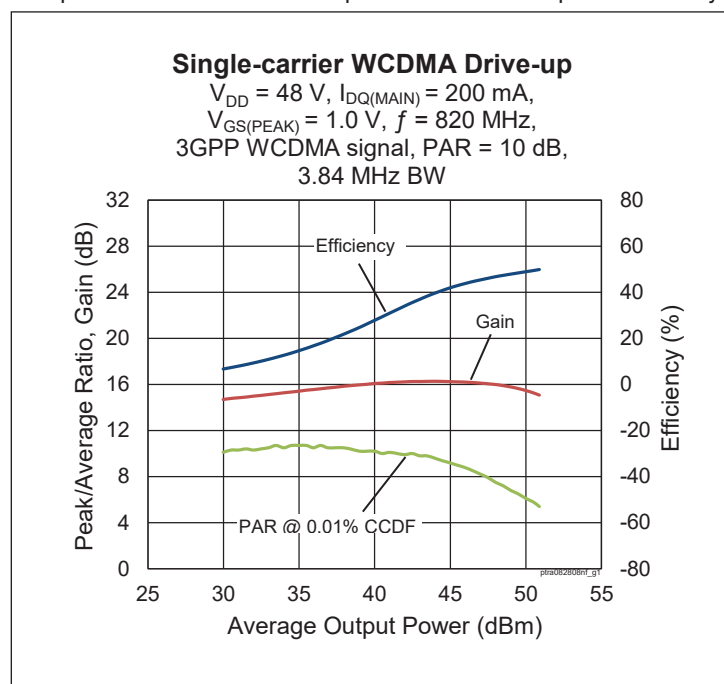

RF Characteristics

Single-carrier WCDMA Specifications (tested in Wolfspeed Doherty test fixture)

$V_{DD} = 48\text{ V}$, $I_{DQ} = 200\text{ mA}$, $V_{GS(PEAK)} = 1.0\text{ V}$, $P_{OUT} = 56.2\text{ W avg}$, $f = 820\text{ MHz}$, 3GPP, channel bandwidth = 3.84 MHz, peak/average = 10 dB @ 0.01% CCDF

Characteristic	Symbol	Min	Typ	Max	Unit
Gain	G_{ps}	15.2	15.5	—	dB
Drain Efficiency	η_D	42.7	44.5	—	%
Adjacent Channel Power Ratio	ACPR	—	-36.4	-33.5	dBc
Output PAR @ 0.01% CCDF	OPAR	6.6	7.3	—	dB

All published data at $T_{CASE} = 25^\circ\text{C}$ unless otherwise indicated

ESD: Electrostatic discharge sensitive device—observe handling precautions!



DC Characteristics (each side)

Characteristic	Conditions	Symbol	Min	Typ	Max	Unit
Drain-Source Breakdown Voltage	$V_{GS} = 0\text{ V}, I_{DS} = 10\text{ mA}$	$V_{(BR)DSS}$	105	—	—	V
Drain Leakage Current	$V_{DS} = 50\text{ V}, V_{GS} = 0\text{ V}$	I_{DSS}	—	—	1	μA
	$V_{DS} = 105\text{ V}, V_{GS} = 0\text{ V}$	I_{DSS}	—	—	10	μA
Gate Leakage Current	$V_{GS} = 10\text{ V}, V_{DS} = 0\text{ V}$	I_{GSS}	—	—	1	μA
On-State Resistance (Main)	$V_{GS} = 10\text{ V}, V_{DS} = 0.1\text{ V}$	$R_{DS(on)}$	—	0.3	—	Ω
	(Peak) $V_{GS} = 10\text{ V}, V_{DS} = 0.1\text{ V}$	$R_{DS(on)}$	—	0.12	—	Ω
Operating Gate Voltage (Main)	$V_{DS} = 3.6\text{ V}, I_{DQ} = 0.2\text{ A}$	V_{GS}	3.0	3.6	4.1	V
	(Peak) $V_{DS} = 1.0\text{ V}, I_{DQ} = 0\text{ A}$	V_{GS}	—	1	—	V

Maximum Ratings

Parameter	Symbol	Value	Unit
Drain-Source Voltage	V_{DSS}	105	V
Gate-Source Voltage	V_{GS}	-6 to +12	V
Operating Voltage	V_{DD}	0 to +55	V
Junction Temperature	T_J	225	$^{\circ}\text{C}$
Storage Temperature Range	T_{STG}	-65 to +150	$^{\circ}\text{C}$

Thermal Characteristics

Parameter	Symbol	Value	Unit
Thermal Resistance (Main, $T_{CASE} = 70^{\circ}\text{C}, 56.2\text{ W CW}$)	$R_{\theta JC}$	0.766	$^{\circ}\text{C/W}$
(Peak, $T_{CASE} = 70^{\circ}\text{C}, 200\text{ W CW}$)	$R_{\theta JC}$	0.208	$^{\circ}\text{C/W}$

Ordering Information

Type and Version	Order Code	Package Description	Shipping
PTRA082808NF V1 R5	PTRA082808NF-V1-R5	PG-HBSOF-6-2	Tape & Reel, 500 pcs

Typical Performance (data taken in a production test fixture)

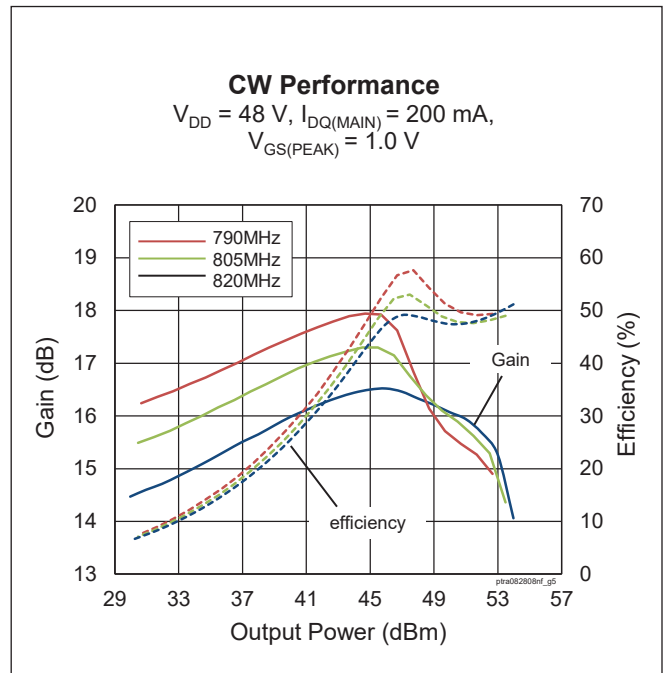
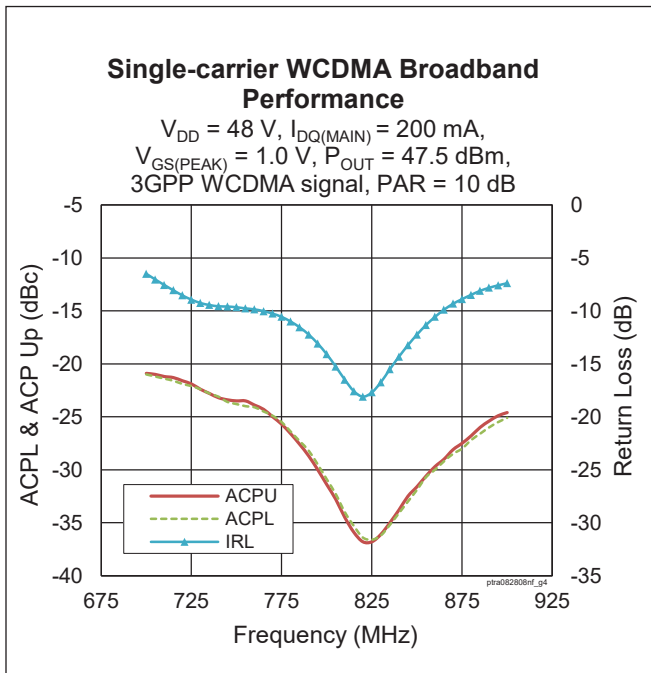
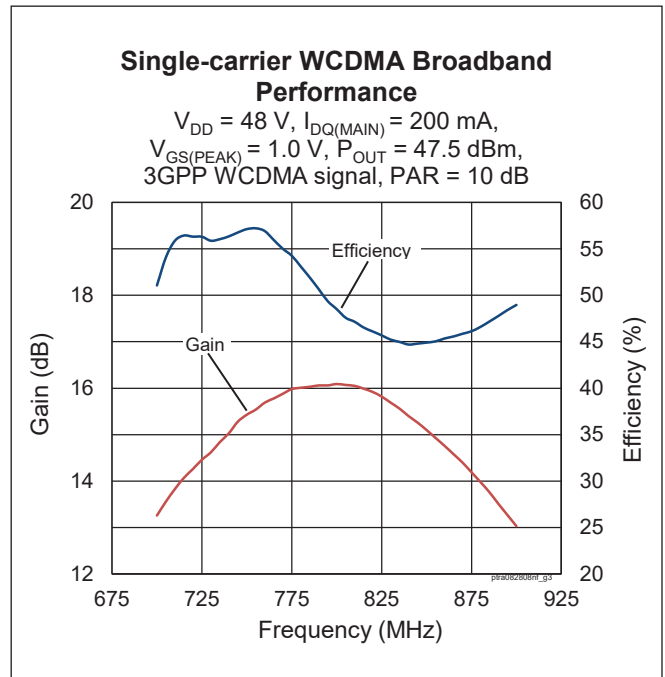
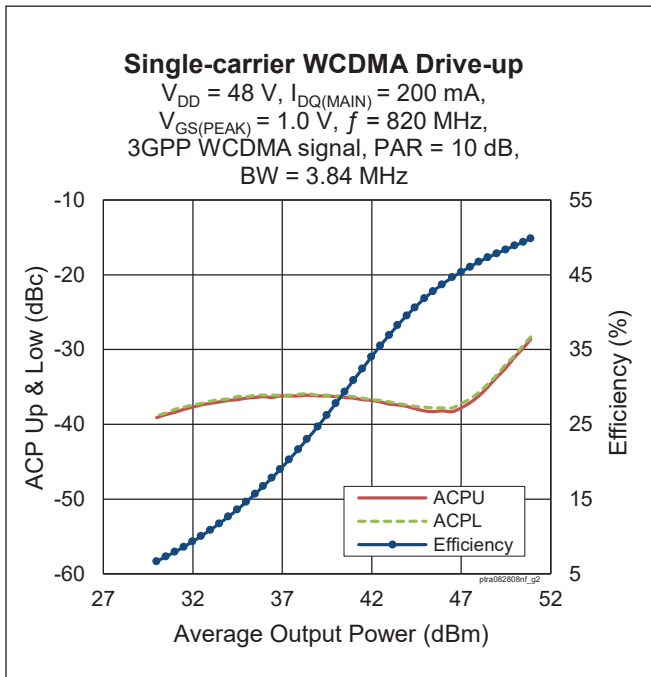



Typical Performance (cont.)

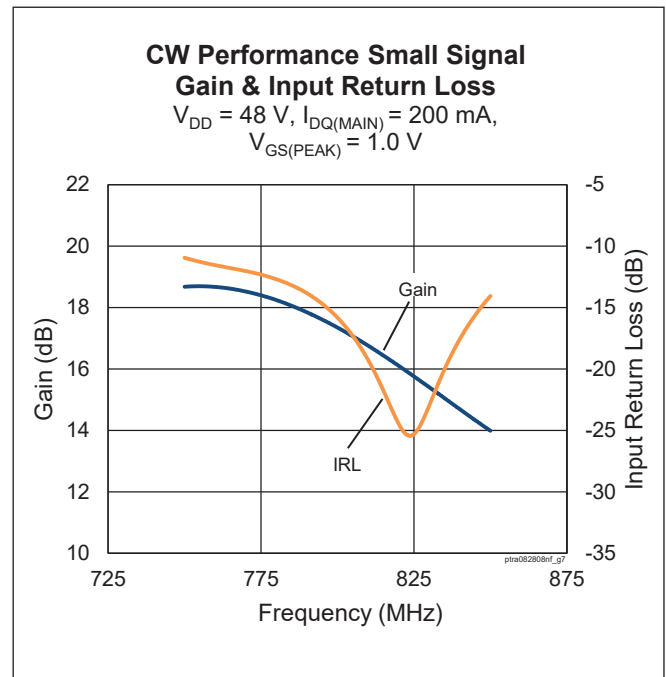
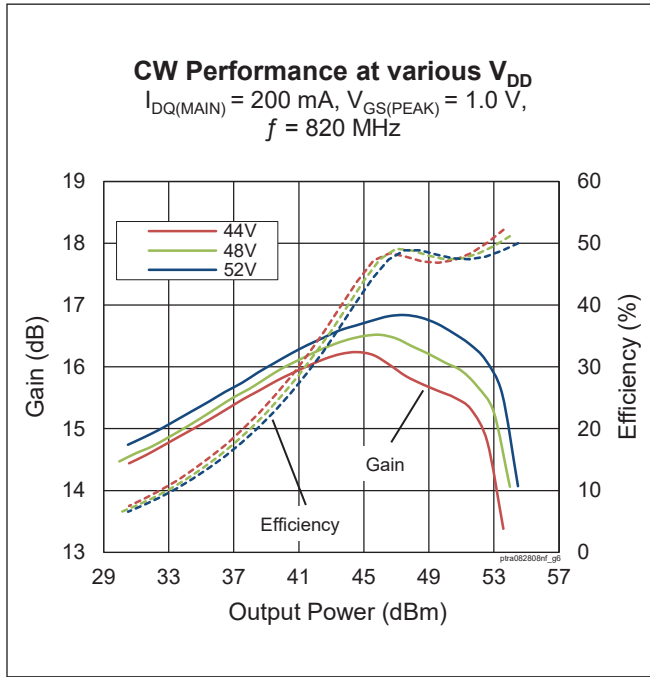



Load Pull Performance

Main Side Load Pull Performance – Pulsed CW signal: 10 μs, 10% duty cycle, 48 V, I_{DQ} = 250 mA

		P _{1dB}									
		Max Output Power					Max Drain Efficiency				
Freq [MHz]	Z _s [Ω]	Z _l [Ω]	Gain [dB]	P _{1dB} [dBm]	P _{1dB} [W]	η _D [%]	Z _l [Ω]	Gain [dB]	P _{1dB} [dBm]	P _{1dB} [W]	η _D [%]
790	1.8 – j4.4	2.4 – j1.6	20.24	51.73	149	58.9	5.4 + j2.6	22.49	48.72	74	69.8
805	1.8 – j5.2	2.6 – j1.8	20.28	51.47	140	58.6	5.4 + j2.5	22.41	48.74	75	70.2
820	1.8 – j5.2	2.9 – j1.8	20.65	51.41	138	60.9	5.3 + j1.9	22.51	48.97	79	70.4

		P _{3dB}									
		Max Output Power					Max Drain Efficiency				
Freq [MHz]	Z _s [Ω]	Z _l [Ω]	Gain [dB]	P _{3dB} [dBm]	P _{3dB} [W]	η _D [%]	Z _l [Ω]	Gain [dB]	P _{3dB} [dBm]	P _{3dB} [W]	η _D [%]
790	1.8 – j4.4	2.6 – j1.9	18.3	52.53	179	62.7	5.5 + j0.2	20.27	50.63	116	71.2
805	1.8 – j5.2	2.8 – j2.6	18.3	52.29	169	60.2	5.6 + j0.0	20.18	50.61	115	71.2
820	1.8 – j5.2	2.9 – j3.1	18.4	52.24	168	60.0	5.6 + j1	20.45	50.13	103	71.3

Peak Side Load Pull Performance – Pulsed CW signal: 10 μs, 10% duty cycle, 48 V, I_{DQ} = 350 mA

		P _{1dB}									
		Max Output Power					Max Drain Efficiency				
Freq [MHz]	Z _s [Ω]	Z _l [Ω]	Gain [dB]	P _{1dB} [dBm]	P _{1dB} [W]	η _D [%]	Z _l [Ω]	Gain [dB]	P _{1dB} [dBm]	P _{1dB} [W]	η _D [%]
790	1.5 – j4.1	1.8 – j1.3	16.26	53.30	214	60.4	3.9 + j1.2	17.03	50.89	123	72.8
805	1.5 – j4.1	1.9 – j1.3	16.02	53.07	203	60.1	3.6 + j1.3	16.84	50.77	119	73.2
820	1.4 – j4.6	2.0 – j1.4	16.4	53.00	200	61.0	3.1 + j2.2	16.87	50.78	120	73.0

		P _{3dB}									
		Max Output Power					Max Drain Efficiency				
Freq [MHz]	Z _s [Ω]	Z _l [Ω]	Gain [dB]	P _{3dB} [dBm]	P _{3dB} [W]	η _D [%]	Z _l [Ω]	Gain [dB]	P _{3dB} [dBm]	P _{3dB} [W]	η _D [%]
790	1.5 – j4.1	2.0 – j1.4	14.37	54.07	255	65.3	3.6 – j0.1	15.05	52.54	180	73.9
805	1.5 – j4.1	2.0 – j2.3	14.84	53.86	243	60.5	3.7 + j1.2	14.84	51.42	139	73.8
820	1.4 – j4.6	2.1 – j1.5	14.43	53.77	238	64.0	3.6 + j0.7	15.13	51.83	152	73.6



Reference Circuit , 790 – 820 MHz

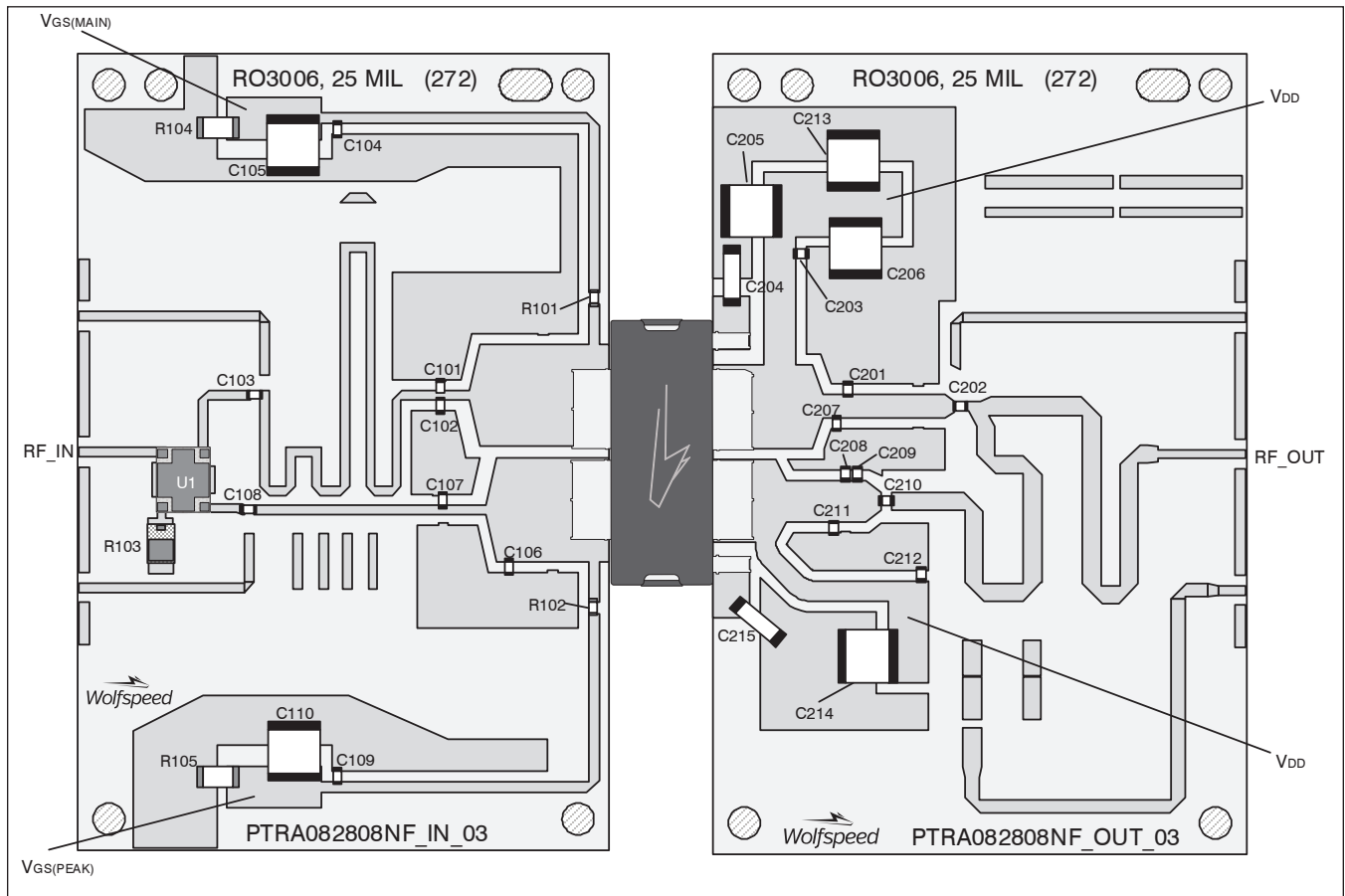

Reference circuit assembly diagram (not to scale)



Reference Circuit (cont.)

Reference Circuit Assembly

DUT	PTRA082808NF V1
Test Fixture Part No.	LTA/PTRA082808NF V1
PCB	Rogers 3006, 0.635 mm [0.025"] thick, 2 oz. copper, $\epsilon_r = 3.66$, $f = 790 - 820$ MHz
Find Gerber files for this test fixture on the Wolfspeed Web site at www.wolfspeed.com/RF	

Components Information

Component	Description	Manufacturer	P/N
Input			
C101, C102	Capacitor, 5.6 pF	ATC	ATC800A5R6CT250T
C103, C104, C108, C109	Capacitor, 56 pF	ATC	ATC800A560JT250T
C105, C110	Capacitor, 10 μ F	TDK Corporation	C5750X5R1H106K230KA
C106	Capacitor, 10 pF	ATC	ATC800A100JT250T
C107	Capacitor, 1.5 pF	ATC	ATC800A1R5CT250T
R101, R102	Resistor, 10 ohms	Panasonic Electronic Components	ERJ-8GEYJ100V
R103	Resistor, 50 ohms	ANAREN	C8A50Z4A
R104, R105	Resistor, 1000 ohms	Panasonic Electronic Components	ERJ-8GEYJ102V
U1	Hybrid Coupler	ANAREN	X3C07P1-05S
Output			
C201	Capacitor, 3.0 pF	ATC	ATC800A3R0CT250T
C202	Capacitor, 15 pF	ATC	ATC800A150JT250T
C203, C210, C212	Capacitor, 82 pF	ATC	ATC800A820JT250T
C204, C205, C206, C213, C214, C215	Capacitor, 10 μ F , 100V	TDK Corporation	C5750X7S2A106M230KB
C207	Capacitor, 6.8 pF	ATC	ATC800A6R8CT250T
C208	Capacitor, 3.9 pF	ATC	ATC800A3R9CT250T
C209	Capacitor, 2.2 pF	ATC	ATC800A2R2CT250T
C211	Capacitor, 10 pF	ATC	ATC800A100JT250T

Pinout Diagram (top view)

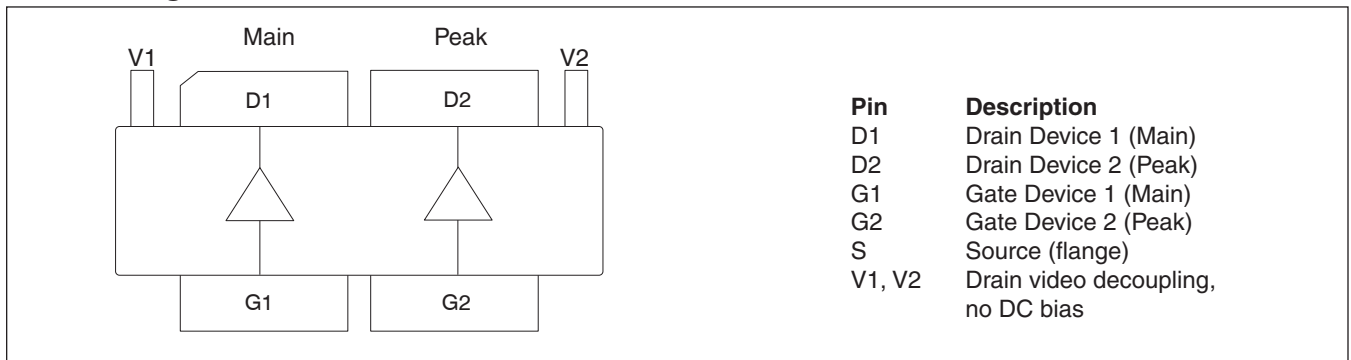



Package Outline Specifications

Package PG-HBSOF-6-2 (top view)

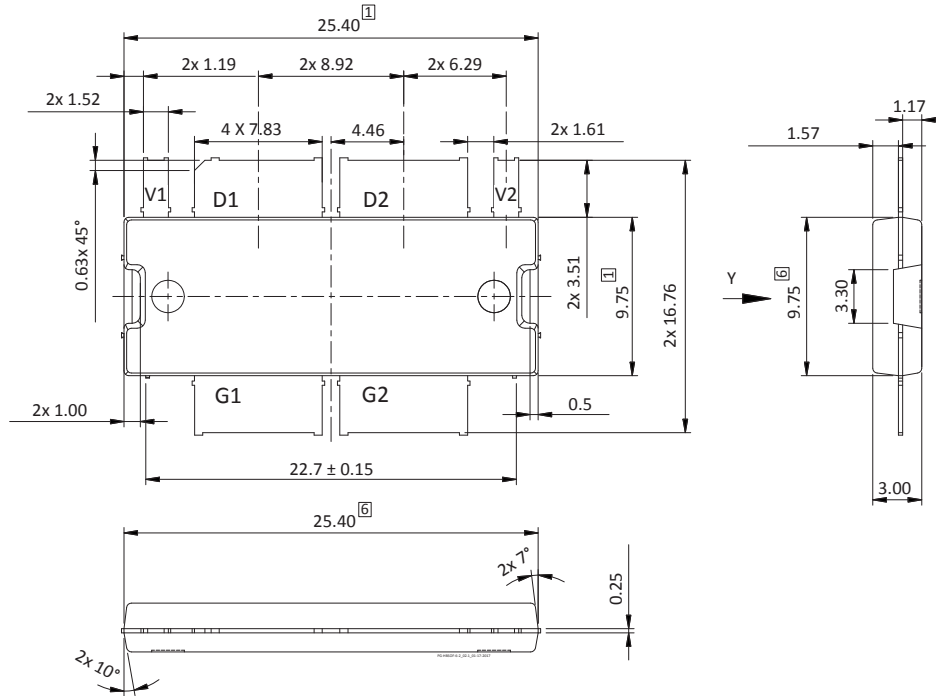

Diagram Notes—unless otherwise specified:

- 1. Mold/dam bar/metal protrusion of 0.30 mm max per side not included.
- 2. Metal protrusions are connected to source and shall not exceed 0.10 mm max.
- 3. Fillets and radii: all radii are 0.3 mm max.
- 4. Interpret dimensions and tolerances per ISO 8015.
- 5. Dimensions are mm.
- 6. Does not include mold/dam bar and metal protrusion.
- 7. Exposed metal surface is tin-plated, may not be covered by mold compound.
- 8. All tolerances ± 0.1 mm unless specified otherwise.
- 9. All metal surfaces are tin-plated, except area of cut.
- 10. Lead thickness: 0.25 mm.
- 11. Pins: D1, D2 = drain; G1, G2 = gate; V1, V2 = drain video decoupling, no DC bias

Package Outline Specifications (cont.)

Package PG-HBSOF-6-2 (bottom view)

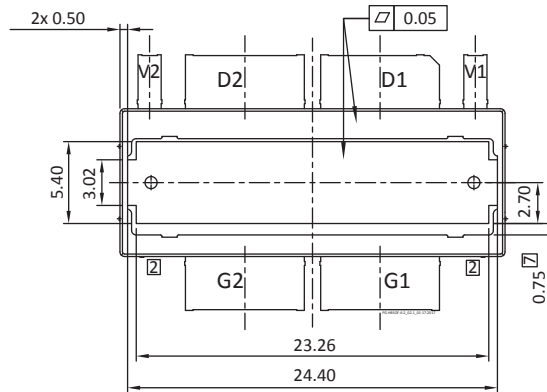

Diagram Notes—unless otherwise specified:

1. Mold/dam bar/metal protrusion of 0.30 mm max per side not included.
2. Metal protrusions are connected to source and shall not exceed 0.10 mm max.
 3. Fillets and radii: all radii are 0.3 mm max.
 4. Interpret dimensions and tolerances per ISO 8015.
 5. Dimensions are mm.
6. Does not include mold/dam bar and metal protrusion.
7. Exposed metal surface is tin-plated, may not be covered by mold compound.
 8. All tolerances ± 0.1 mm unless specified otherwise.
 9. All metal surfaces are tin-plated, except area of cut.
 10. Lead thickness: 0.25 mm.
 11. Pins: D1, D2 = drain; G1, G2 = gate; V1, V2 = drain video decoupling, no DC bias

Revision History

Revision	Date	Data Sheet Type	Page	Subjects (major changes since last revision)
01	2016-05-18	Advance	All	Data Sheet reflects advance specification for product development
01.1	2016-09-06	Advance	1	Revised frequency range
02	2016-11-01	Advance	2 3,4	Revised pinout diagram Revised package outline
03	2016-11-04	Production	All	Data Sheet reflects released product specification
03.1	2016-12-07	Production	1	Revised Maximum Ratings table
03.2	2017-01-12	Production	8, 9	Revised typo in package outline
03.3	2017-03-30	Production	1 3, 4	Updated RF Characteristics table Fixed missing labels on CW performance graphs
04	2017-08-21	Production	6, 7	Updated PCB layout and components information
04.1	2017-01-30	Production	1, 2	Corrected unit for OPAR. Corrected Operating gate voltage for main and peak sides.
05	2018-06-20	Production	All	Converted to Wolfspeed Data Sheet

For more information, please contact:

4600 Silicon Drive
Durham, North Carolina, USA 27703
www.wolfspeed.com/RF

Sales Contact
RFSales@wolfspeed.com

RF Product Marketing Contact
RFMarketing@wolfspeed.com
919.407.7816

Notes

Disclaimer

Specifications are subject to change without notice. Cree, Inc. believes the information contained within this data sheet to be accurate and reliable. However, no responsibility is assumed by Cree for any infringement of patents or other rights of third parties which may result from its use. No license is granted by implication or otherwise under any patent or patent rights of Cree. Cree makes no warranty, representation or guarantee regarding the suitability of its products for any particular purpose. "Typical" parameters are the average values expected by Cree in large quantities and are provided for information purposes only. These values can and do vary in different applications and actual performance can vary over time. All operating parameters should be validated by customer's technical experts for each application. Cree products are not designed, intended or authorized for use as components in applications intended for surgical implant into the body or to support or sustain life, in applications in which the failure of the Cree product could result in personal injury or death or in applications for planning, construction, maintenance or direct operation of a nuclear facility.



Стандарт Электрон Связь

Мы молодая и активно развивающаяся компания в области поставок электронных компонентов. Мы поставляем электронные компоненты отечественного и импортного производства напрямую от производителей и с крупнейших складов мира.

Благодаря сотрудничеству с мировыми поставщиками мы осуществляем комплексные и плановые поставки широчайшего спектра электронных компонентов.

Собственная эффективная логистика и склад в обеспечивает надежную поставку продукции в точно указанные сроки по всей России.

Мы осуществляем техническую поддержку нашим клиентам и предпродажную проверку качества продукции. На все поставляемые продукты мы предоставляем гарантию .

Осуществляем поставки продукции под контролем ВП МО РФ на предприятия военно-промышленного комплекса России , а также работаем в рамках 275 ФЗ с открытием отдельных счетов в уполномоченном банке. Система менеджмента качества компании соответствует требованиям ГОСТ ISO 9001.

Минимальные сроки поставки, гибкие цены, неограниченный ассортимент и индивидуальный подход к клиентам являются основой для выстраивания долгосрочного и эффективного сотрудничества с предприятиями радиоэлектронной промышленности, предприятиями ВПК и научно-исследовательскими институтами России.

С нами вы становитесь еще успешнее!

Наши контакты:

Телефон: +7 812 627 14 35

Электронная почта: sales@st-electron.ru

Адрес: 198099, Санкт-Петербург,
Промышленная ул, дом № 19, литера Н,
помещение 100-Н Офис 331