

Low Current SMD LED



FEATURES

- SMD LED with exceptional brightness
- Compatible with automatic placement equipment
- EIA and ICE standard package
- Compatible with IR reflow, vapor phase and wave solder processes according to CECC 00802 and J-STD-020
- Available in 8 mm tape
- Low profile package
- Non-diffused lens: excellent for coupling to light pipes and backlighting
- Very low power consumption
- Luminous intensity ratio in one packaging unit $I_{Vmax.}/I_{Vmin.} \leq 1.6$
- ESD withstand voltage: up to 2 kV according to JESD22-A114-B
- Preconditioning: according to JEDEC level 2a
- AEC-Q101 qualified
- Compliant to RoHS directive 2002/95/EC and in accordance to WEEE 2002/96/EC

RoHS
COMPLIANT

DESCRIPTION

These new devices have been designed to meet the increasing demand for AlInGaP based low current SMD LEDs.

The package of the VLM.30.. is the PLCC-2 package. It consists of a lead frame which is embedded in a white thermoplast. The reflector inside this package is filled up with clear epoxy.

PRODUCT GROUP AND PACKAGE DATA

- Product group: LED
- Package: SMD PLCC-2
- Product series: low current
- Angle of half intensity: $\pm 60^\circ$

APPLICATIONS

- Automotive: backlighting in dashboards and switches
- Telecommunication: indicator and backlighting in telephone and fax
- Indicator and backlight for audio and video equipment
- Indicator and backlight for battery driven equipment
- Indicator and backlight in office equipment
- Flat backlight for LCDs, switches and symbols
- General use

PARTS TABLE		
PART	COLOR, LUMINOUS INTENSITY	TECHNOLOGY
VLMS3000-GS08	Super red, $I_V > 2.8$ mcd	AlInGaP
VLMS3000-GS18	Super red, $I_V > 2.8$ mcd	AlInGaP
VLMS30J1K2-GS08	Super red, $I_V = (4.5 \text{ to } 11.2)$ mcd	AlInGaP
VLMS30J1K2-GS18	Super red, $I_V = (4.5 \text{ to } 11.2)$ mcd	AlInGaP
VLMS30K1L2-GS08	Super red, $I_V = (7.1 \text{ to } 18)$ mcd	AlInGaP
VLMS30K1L2-GS18	Super red, $I_V = (7.1 \text{ to } 18)$ mcd	AlInGaP

PARTS TABLE		
PART	COLOR, LUMINOUS INTENSITY	TECHNOLOGY
VLMS30J1L2-GS08	Super red, $I_V = (4.5 \text{ to } 18) \text{ mcd}$	AllnGaP
VLMS30J1L2-GS18	Super red, $I_V = (4.5 \text{ to } 18) \text{ mcd}$	AllnGaP
VLMS30J2K2-GS08	Super red, $I_V = (5.6 \text{ to } 11.2) \text{ mcd}$	AllnGaP
VLMS30J2K2-GS18	Super red, $I_V = (5.6 \text{ to } 11.2) \text{ mcd}$	AllnGaP
VLMS30K2L2-GS08	Super red, $I_V = (9 \text{ to } 18) \text{ mcd}$	AllnGaP
VLMO3000-GS08	Orange, $I_V > 5.6 \text{ mcd}$	AllnGaP
VLMO3000-GS18	Orange, $I_V > 5.6 \text{ mcd}$	AllnGaP
VLMO30K1L2-GS08	Orange, $I_V = (7.1 \text{ to } 18) \text{ mcd}$	AllnGaP
VLMO30K1L2-GS18	Orange, $I_V = (7.1 \text{ to } 18) \text{ mcd}$	AllnGaP
VLMO30L1M2-GS08	Orange, $I_V = (11.2 \text{ to } 28) \text{ mcd}$	AllnGaP
VLMO30L1M2-GS18	Orange, $I_V = (11.2 \text{ to } 28) \text{ mcd}$	AllnGaP
VLMO30K1M2-GS08	Orange, $I_V = (7.1 \text{ to } 28) \text{ mcd}$	AllnGaP
VLMO30K1M2-GS18	Orange, $I_V = (7.1 \text{ to } 28) \text{ mcd}$	AllnGaP
VLMY3000-GS08	Yellow, $I_V > 4.5 \text{ mcd}$	AllnGaP
VLMY3000-GS18	Yellow, $I_V > 4.5 \text{ mcd}$	AllnGaP
VLMY3001GS08	Yellow, $I_V = (7.1 \text{ to } 18) \text{ mcd}$	AllnGaP
VLMY3001-GS18	Yellow, $I_V = (7.1 \text{ to } 18) \text{ mcd}$	AllnGaP
VLMY30J2L1-GS08	Yellow, $I_V = (5.6 \text{ to } 14) \text{ mcd}$	AllnGaP
VLMY30J2L1-GS18	Yellow, $I_V = (5.6 \text{ to } 14) \text{ mcd}$	AllnGaP
VLMY30K2M1-GS08	Yellow, $I_V = (9 \text{ to } 22.4) \text{ mcd}$	AllnGaP
VLMY30K2M1-GS18	Yellow, $I_V = (9 \text{ to } 22.4) \text{ mcd}$	AllnGaP
VLMY30J2M1-GS08	Yellow, $I_V = (5.6 \text{ to } 22.4) \text{ mcd}$	AllnGaP
VLMY30J2M1-GS18	Yellow, $I_V = (5.6 \text{ to } 22.4) \text{ mcd}$	AllnGaP

ABSOLUTE MAXIMUM RATINGS ¹⁾ VLM30..				
PARAMETER	TEST CONDITION	SYMBOL	VALUE	UNIT
Reverse voltage ²⁾		V_R	6	V
DC forward current		I_F	15	mA
Surge forward current	$t_p \leq 10 \mu\text{s}$	I_{FSM}	0.1	A
Power dissipation		P_V	40	mW
Junction temperature		T_j	125	°C
Operating temperature range		T_{amb}	- 40 to + 100	°C
Storage temperature range		T_{stg}	- 40 to + 100	°C
Thermal resistance junction/ambient	Mounted on PC board (pad size > 16 mm ²)	R_{thJA}	400	K/W

Note:

¹⁾ $T_{amb} = 25 \text{ °C}$, unless otherwise specified

²⁾ Driving the LED in reverse direction is suitable for short term application

**OPTICAL AND ELECTRICAL CHARACTERISTICS ¹⁾ VLMS30..., RED**

PARAMETER	TEST CONDITION	PART	SYMBOL	MIN.	TYP.	MAX.	UNIT
Luminous intensity ²⁾	$I_F = 2 \text{ mA}$	VLMS3000	I_V	2.8			mcd
	$I_F = 10 \text{ mA}$	VLMS3000	I_V		20		mcd
	$I_F = 2 \text{ mA}$	VLMS30J1K2	I_V	4.5		11.2	mcd
	$I_F = 2 \text{ mA}$	VLMS30K1L2	I_V	7.1		18	mcd
	$I_F = 2 \text{ mA}$	VLMS30J1L2	I_V	4.5		18	mcd
	$I_F = 2 \text{ mA}$	VLMS30J2K2	I_V	5.6		11.2	mcd
	$I_F = 2 \text{ mA}$	VLMS30K2L2	I_V	9		18	mcd
Dominant wavelength	$I_F = 2 \text{ mA}$		λ_d	624		636	nm
Peak wavelength	$I_F = 2 \text{ mA}$		λ_p		635		nm
Angle of half intensity	$I_F = 2 \text{ mA}$		ϕ		± 60		deg
Forward voltage	$I_F = 2 \text{ mA}$		V_F		1.8	2.2	V
Reverse voltage	$I_R = 10 \mu\text{A}$		V_R	6	15		V

Note:

¹⁾ $T_{amb} = 25 \text{ }^\circ\text{C}$, unless otherwise specified²⁾ In one packing unit $I_{Vmax}/I_{Vmin} \leq 1.6$ **OPTICAL AND ELECTRICAL CHARACTERISTICS ¹⁾ VLMO30..., ORANGE**

PARAMETER	TEST CONDITION	PART	SYMBOL	MIN.	TYP.	MAX.	UNIT
Luminous intensity ²⁾	$I_F = 2 \text{ mA}$	VLMO3000	I_V	5.6			mcd
	$I_F = 10 \text{ mA}$	VLMO3000	I_V		50		mcd
	$I_F = 2 \text{ mA}$	VLMO30K1L2	I_V	7.1		18	mcd
	$I_F = 2 \text{ mA}$	VLMO30L1M2	I_V	11.2		28	mcd
	$I_F = 2 \text{ mA}$	VLMO30K1M2	I_V	7.1		28	mcd
Dominant wavelength	$I_F = 2 \text{ mA}$		λ_d	600		609	nm
Peak wavelength	$I_F = 2 \text{ mA}$		λ_p		610		nm
Angle of half intensity	$I_F = 2 \text{ mA}$		ϕ		± 60		deg
Forward voltage	$I_F = 2 \text{ mA}$		V_F		1.8	2.2	V
Reverse voltage	$I_R = 10 \mu\text{A}$		V_R	6	15		V

Note:

¹⁾ $T_{amb} = 25 \text{ }^\circ\text{C}$, unless otherwise specified²⁾ In one packing unit $I_{Vmax}/I_{Vmin} \leq 1.6$ **OPTICAL AND ELECTRICAL CHARACTERISTICS ¹⁾ VLMY30..., YELLOW**

PARAMETER	TEST CONDITION	PART	SYMBOL	MIN.	TYP.	MAX.	UNIT
Luminous intensity ²⁾	$I_F = 2 \text{ mA}$	VLMY3000	I_V	4.5			mcd
	$I_F = 10 \text{ mA}$	VLMY3000	I_V		50		mcd
	$I_F = 10 \text{ mA}$	VLMY3001	I_V	7.1		18	mcd
	$I_F = 2 \text{ mA}$	VLMY30J2L1	I_V	5.6		14	mcd
	$I_F = 2 \text{ mA}$	VLMY30K2M1	I_V	9		22.4	mcd
	$I_F = 2 \text{ mA}$	VLMY30J2M1	I_V	5.6		22.4	mcd
Dominant wavelength	$I_F = 2 \text{ mA}$		λ_d	581		594	nm
Peak wavelength	$I_F = 2 \text{ mA}$		λ_p		585		nm
Angle of half intensity	$I_F = 2 \text{ mA}$		ϕ		± 60		deg
Forward voltage	$I_F = 2 \text{ mA}$		V_F		1.8	2.2	V
Reverse voltage	$I_R = 10 \mu\text{A}$		V_R	6	15		V

Note:

¹⁾ $T_{amb} = 25 \text{ }^\circ\text{C}$, unless otherwise specified²⁾ In one packing unit $I_{Vmax}/I_{Vmin} \leq 1.6$



LUMINOUS INTENSITY CLASSIFICATION			
GROUP	LIGHT INTENSITY (mcd)		
STANDARD	OPTIONAL	MIN.	MAX.
H	1	2.8	3.55
	2	3.55	4.5
J	1	4.5	5.6
	2	5.6	7.1
K	1	7.1	9.0
	2	9.0	11.2
L	1	11.2	14.0
	2	14.0	18.0
M	1	18.0	22.4
	2	22.4	28.0

Note:

Luminous Intensity is tested at a current pulse duration of 25 ms and an accuracy of $\pm 11\%$. The above type numbers represent the order groups which include only a few brightness groups. Only one group will be shipped in one reel (there will be no mixing of two groups on each reel). In order to ensure availability, single brightness groups will not be orderable. In a similar manner for colors where wavelength groups are measured and binned, single wavelength groups will be shipped in any one reel. In order to ensure availability, single wavelength groups will not be orderable.

COLOR CLASSIFICATION				
GROUP	YELLOW		ORANGE	
	DOM. WAVELENGTH (nm)			
	MIN.	MAX.	MIN.	MAX.
1	581	584		
2	583	586	600	603
3	585	588	602	605
4	587	590	604	607
5	589	592	606	609
6	591	594		

Note:

Wavelengths are tested at a current pulse duration of 25 ms and an accuracy of ± 1 nm.

CROSSING TABLE	
VISHAY	OSRAM
VLMO30K1L2	LOT67K-K1L2
VLMO30K1M2	LOT67K-K1M2
VLMO30L1M2	LOT67K-L1M2
VLMS30J1K2	LST67K-J1K2
VLMS30J1L2	LST67K-J1L2
VLMS30K1L2	LST67K-K1L2
VLMY30J2L1	LYT67K-J2L1
VLMY30J2M1	LYT67K-J2M1
VLMY30K2M1	LYT67K-K2M1

TYPICAL CHARACTERISTICS

$T_{amb} = 25^\circ\text{C}$, unless otherwise specified

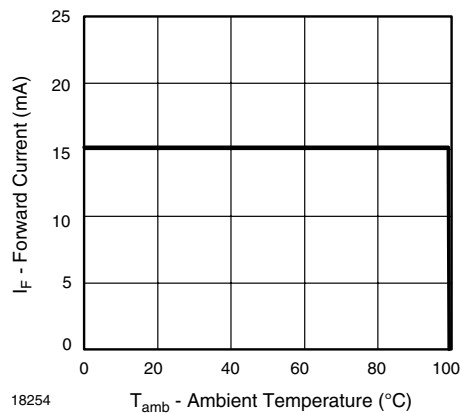

Figure 1. Forward Current vs. Ambient Temperature



Figure 2. Forward Current vs. Pulse Length



Figure 3. Rel. Luminous Intensity vs. Angular Displacement



Figure 6. Rel. Luminous Intensity vs. Ambient Temperature



Figure 4. Relative Intensity vs. Wavelength

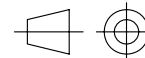

Figure 7. Forward Voltage vs. Ambient Temperature



Figure 5. Forward Current vs. Forward Voltage

PACKAGE DIMENSIONS in millimeters



technical drawings
according to DIN
specifications



Mounting Pad Layout

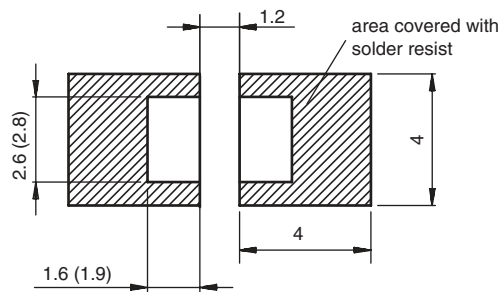

Drawing-No.: 6.541-5067.01-4
Issue: 5; 04.11.08
20541

METHOD OF TAPING/POLARITY AND TAPE AND REEL

SMD LED (VLM.3 - SERIES)

Vishay's LEDs in SMD packages are available in an antistatic 8 mm blister tape (in accordance with DIN IEC 40 (CO) 564) for automatic component insertion. The blister tape is a plastic strip with impressed component cavities, covered by a top tape.



REEL PACKAGE DIMENSION IN MILLIMETERS FOR SMD LEDS, TAPE OPTION GS08 (= 1500 PCS.)

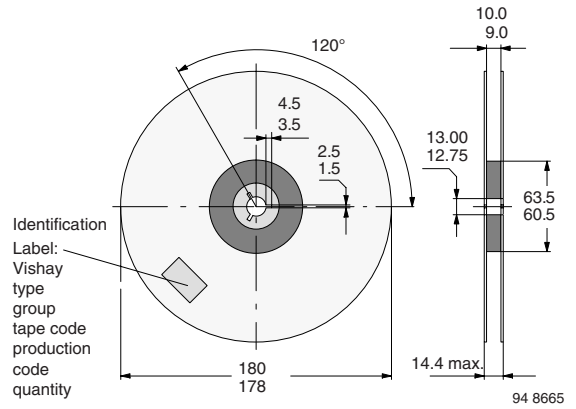

Figure 9. Reel Dimensions - GS08

TAPING OF VLM.3...



Figure 8. Tape Dimensions in mm for PLCC-2

REEL PACKAGE DIMENSION IN MILLIMETERS FOR SMD LEDS, TAPE OPTION GS18 (= 8000 PCS.) PREFERRED

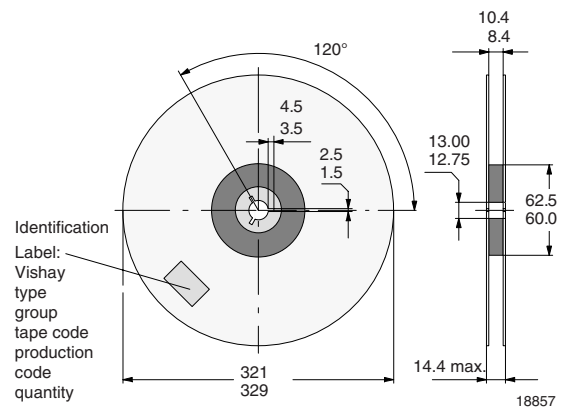

Figure 10. Reel Dimensions - GS18

SOLDERING PROFILE



Figure 11. Vishay Lead (Pb)-free Reflow Soldering Profile (acc. to J-STD-020)

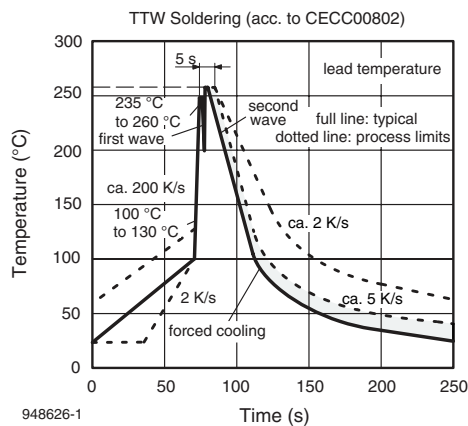

Figure 12. Double Wave Soldering of Opto Devices (all Packages)

BAR CODE PRODUCT LABEL EXAMPLE:



- A) Type of component
- B) Manufacturing plant
- C) SEL - selection code (bin):
e.g.: K1 = code for luminous intensity group
3 = code for color group
- D) Date code year/week
- E) Day code (e.g. 5: Friday)
- F) Batch no.
- G) Total quantity
- H) Company code



Disclaimer

All product specifications and data are subject to change without notice.

Vishay Intertechnology, Inc., its affiliates, agents, and employees, and all persons acting on its or their behalf (collectively, "Vishay"), disclaim any and all liability for any errors, inaccuracies or incompleteness contained herein or in any other disclosure relating to any product.

Vishay disclaims any and all liability arising out of the use or application of any product described herein or of any information provided herein to the maximum extent permitted by law. The product specifications do not expand or otherwise modify Vishay's terms and conditions of purchase, including but not limited to the warranty expressed therein, which apply to these products.

No license, express or implied, by estoppel or otherwise, to any intellectual property rights is granted by this document or by any conduct of Vishay.

The products shown herein are not designed for use in medical, life-saving, or life-sustaining applications unless otherwise expressly indicated. Customers using or selling Vishay products not expressly indicated for use in such applications do so entirely at their own risk and agree to fully indemnify Vishay for any damages arising or resulting from such use or sale. Please contact authorized Vishay personnel to obtain written terms and conditions regarding products designed for such applications.

Product names and markings noted herein may be trademarks of their respective owners.



Стандарт Электрон Связь

Мы молодая и активно развивающаяся компания в области поставок электронных компонентов. Мы поставляем электронные компоненты отечественного и импортного производства напрямую от производителей и с крупнейших складов мира.

Благодаря сотрудничеству с мировыми поставщиками мы осуществляем комплексные и плановые поставки широчайшего спектра электронных компонентов.

Собственная эффективная логистика и склад в обеспечивает надежную поставку продукции в точно указанные сроки по всей России.

Мы осуществляем техническую поддержку нашим клиентам и предпродажную проверку качества продукции. На все поставляемые продукты мы предоставляем гарантию .

Осуществляем поставки продукции под контролем ВП МО РФ на предприятия военно-промышленного комплекса России , а также работаем в рамках 275 ФЗ с открытием отдельных счетов в уполномоченном банке. Система менеджмента качества компании соответствует требованиям ГОСТ ISO 9001.

Минимальные сроки поставки, гибкие цены, неограниченный ассортимент и индивидуальный подход к клиентам являются основой для выстраивания долгосрочного и эффективного сотрудничества с предприятиями радиоэлектронной промышленности, предприятиями ВПК и научно-исследовательскими институтами России.

С нами вы становитесь еще успешнее!

Наши контакты:

Телефон: +7 812 627 14 35

Электронная почта: sales@st-electron.ru

Адрес: 198099, Санкт-Петербург,
Промышленная ул, дом № 19, литера Н,
помещение 100-Н Офис 331