

Thermocouple measuring transducer - MINI MCR-2-TC-UI - 2902055

Please be informed that the data shown in this PDF Document is generated from our Online Catalog. Please find the complete data in the user's documentation. Our General Terms of Use for Downloads are valid (<http://phoenixcontact.com/download>)



Configurable temperature transducer with plug-in connection technology for connecting thermocouples. Configurable via DIP switch or software. Screw connection technology, standard configuration

The figure shows the MINI MCR-2-TC-UI-PT version

Product description

Configurable, 3-way isolated temperature transducer with plug-in connection technology. The device is suitable for the connection of thermocouples. The measured values are converted into a linear and freely adjustable current or voltage signal. You can configure the device using one of the free software solutions. Default settings can also be made directly on the device by simply using the DIP switches (see configuration table). The measuring transducer supports fault monitoring and NFC communication.



Key commercial data

Packing unit	1 pc
Weight per Piece (excluding packing)	100.0 GRM
Custom tariff number	85437090
Country of origin	Germany

Technical data

Note

Utilization restriction	EMC: class A product, see manufacturer's declaration in the download area
-------------------------	---

Dimensions

Width	6.2 mm
Height	110.5 mm
Depth	120.5 mm

Ambient conditions

Ambient temperature (operation)	-40 °C ... 70 °C
---------------------------------	------------------

Thermocouple measuring transducer - MINI MCR-2-TC-UI - 2902055

Technical data

Ambient conditions

Ambient temperature (storage/transport)	-40 °C ... 85 °C
Degree of protection	IP20

Input data

Configurable/programmable	Yes
Sensor types that can be used (TC)	B, E, J, K, N, R, S, T, L, U, A-1, A-2, A-3, M, L
Temperature measuring range	-250 °C ... 2500 °C (Range depends on sensor type, range can be set freely via software or in increments from -150°C to 1350°C via DIP switches)

Output data

Number of inputs	1
Configurable/programmable	Yes
Voltage output signal	0 V ... 5 V (via DIP switch)
	1 V ... 5 V (via DIP switch)
	0 V ... 10 V (via DIP switch)
	10 V ... 0 V (via DIP switch)
	0 V ... 10.5 V (Can be set via software)
Current output signal	0 mA ... 20 mA (via DIP switch)
	4 mA ... 20 mA (via DIP switch)
	20 mA ... 0 mA (via DIP switch)
	20 mA ... 4 mA (via DIP switch)
	0 mA ... 21 mA (Can be set via software)
Max. output voltage	approx. 12.3 V
Max. output current	24.6 mA
Short-circuit current	< 31.5 mA
Load/output load voltage output	≥ 10 kΩ
Load/output load current output	≤ 600 Ω (at 20 mA)

Power supply

Supply voltage range	9.6 V DC ... 30 V DC (The DIN rail bus connector (ME 6,2 TBUS-2 1,5/5-ST-3,81 GN, Order No. 2869728) can be used to bridge the supply voltage. It can be snapped onto a 35 mm DIN rail according to EN 60715))
Typical current consumption	32.7 mA (24 V DC)
	66.8 mA (12 V DC)
Power consumption	≤ 850 mW (at I _{OUT} = 20 mA, 9.6 V DC, 600 Ω load)

Connection data

Connection method	Screw connection
Single conductor/terminal point, solid, with ferrule, min.	0.2 mm ²
Single conductor/terminal point, solid, with ferrule, max.	1.5 mm ²

Thermocouple measuring transducer - MINI MCR-2-TC-UI - 2902055

Technical data

Connection data

Single conductor/terminal point, solid, without ferrule, min.	0.2 mm ²
Single conductor/terminal point, solid, without ferrule, max.	2.5 mm ²
Conductor cross section flexible min.	0.2 mm ²
Conductor cross section flexible max.	1.5 mm ²
Min. AWG conductor cross section, flexible	24
Max. AWG conductor cross section, flexible	12
Stripping length	10 mm
Screw thread	M3

General

Maximum temperature coefficient	≤ 0.01 %/K
Typical cold point errors	2 K (2 K + (0,2 K * ΔT))
Protective circuit	Transient protection
Electrical isolation	Reinforced insulation in accordance with IEC 61010-1
Surge voltage category	II
Pollution degree	2
Rated insulation voltage	300 V
Test voltage, input/output/supply	3 kV (50 Hz, 1 min.)
Electromagnetic compatibility	Conformance with EMC Directive 2004/108/EC
Noise emission	EN 61000-6-4
Noise immunity	EN 61000-6-2 When being exposed to interference, there may be minimal deviations.
Housing material	PBT
Mounting position	any
Assembly instructions	The T connector can be used to bridge the supply voltage. It can be snapped onto a 35 mm DIN rail according to EN 60715.
Conformance	CE-compliant
ATEX	# II 3 G Ex nA IIC T4 Gc X
UL, USA / Canada	UL 508 Listed
	Class I, Div. 2, Groups A, B, C, D T6
	Class I, Zone 2, Group IIC T6

EMC data

Designation	Electromagnetic RF field
Standards/regulations	EN 61000-4-3
Typical deviation from the measuring range final value	0.06 %
Designation	Fast transients (burst)
Standards/regulations	EN 61000-4-4
Typical deviation from the measuring range final value	0.1 %

Thermocouple measuring transducer - MINI MCR-2-TC-UI - 2902055

Technical data

EMC data

Designation	Conducted interferences
Standards/regulations	EN 61000-4-6
Typical deviation from the measuring range final value	0.05 %

Classifications

eCl@ss

eCl@ss 4.0	27210120
eCl@ss 4.1	27210120
eCl@ss 5.0	27210120
eCl@ss 5.1	27210120
eCl@ss 6.0	27210120
eCl@ss 7.0	27210120
eCl@ss 8.0	27371503

ETIM

ETIM 3.0	EC001485
ETIM 4.0	EC001446
ETIM 5.0	EC002568

UNSPSC

UNSPSC 6.01	30211506
UNSPSC 7.0901	39121008
UNSPSC 11	39121008
UNSPSC 12.01	39121008
UNSPSC 13.2	39121008

Approvals

Approvals

Approvals

UL Listed / cUL Listed / GL / cULus Listed

Ex Approvals

ATEX / UL Listed / cUL Listed / cULus Listed

Thermocouple measuring transducer - MINI MCR-2-TC-UI - 2902055

Approvals

Approvals submitted

Approval details

UL Listed

cUL Listed

GL

cULus Listed

Drawings

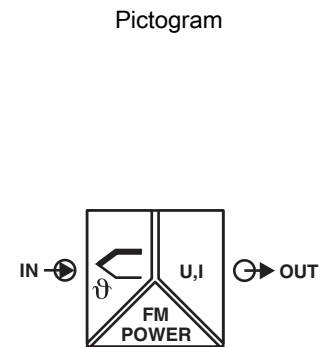
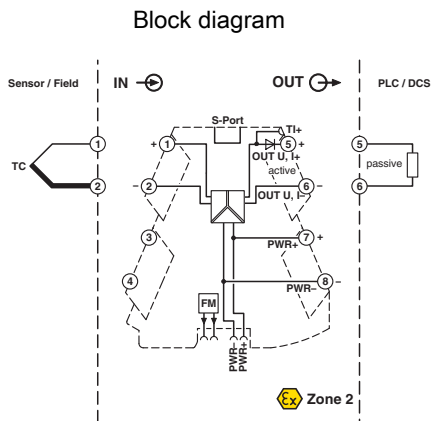



Стандарт Электрон Связь

Мы молодая и активно развивающаяся компания в области поставок электронных компонентов. Мы поставляем электронные компоненты отечественного и импортного производства напрямую от производителей и с крупнейших складов мира.

Благодаря сотрудничеству с мировыми поставщиками мы осуществляем комплексные и плановые поставки широчайшего спектра электронных компонентов.

Собственная эффективная логистика и склад в обеспечивает надежную поставку продукции в точно указанные сроки по всей России.

Мы осуществляем техническую поддержку нашим клиентам и предпродажную проверку качества продукции. На все поставляемые продукты мы предоставляем гарантию .

Осуществляем поставки продукции под контролем ВП МО РФ на предприятия военно-промышленного комплекса России , а также работаем в рамках 275 ФЗ с открытием отдельных счетов в уполномоченном банке. Система менеджмента качества компании соответствует требованиям ГОСТ ISO 9001.

Минимальные сроки поставки, гибкие цены, неограниченный ассортимент и индивидуальный подход к клиентам являются основой для выстраивания долгосрочного и эффективного сотрудничества с предприятиями радиоэлектронной промышленности, предприятиями ВПК и научно-исследовательскими институтами России.

С нами вы становитесь еще успешнее!

Наши контакты:

Телефон: +7 812 627 14 35

Электронная почта: sales@st-electron.ru

Адрес: 198099, Санкт-Петербург,
Промышленная ул, дом № 19, литера Н,
помещение 100-Н Офис 331