



MIC3223

High Power Boost LED Driver with Integrated FET

General Description

The MIC3223 is a constant current boost LED driver capable of driving a series string of high power LEDs. The MIC3223 can be used in general lighting, bulb replacement, garden pathway lighting and other solid state illumination applications.

The MIC3223 is a peak current mode control PWM boost regulator and the 4.5V and 20V operating input voltage range allows multiple applications from a 5V or a 12V bus.

The MIC3223 implements a fixed internal 1MHz switching frequency to allow for a reduction in the design footprint size. Power consumption has been minimized through the implementation of a 200mV feedback voltage that provides an accuracy of $\pm 5\%$. The MIC3223 can be dimmed through the use of a PWM signal and features an enable pin for a low power shutdown state.

The MIC3223 is a very robust LED driver and offers the following protection features: over voltage protection (OVP), thermal shutdown, switch current limiting and under voltage lockout (UVLO).

The MIC3223 is offered in a low profile exposed pad 16-pin TSSOP package.

Data sheets and support documentation can be found on Micrel's web site at: www.micrel.com.

Features

- 4.5V to 20V supply voltage
- 200mV feedback voltage with an accuracy of $\pm 5\%$
- Step-up output voltage (boost) conversion up to 37V
- 1MHz switching frequency
- 100m Ω /3.5A internal power FET switch
- LEDs can be dimmed using a PWM signal
- User settable LED current (through external resistor)
- Externally programmable soft-start
- Protection features that include:
 - Output over-voltage protection (OVP)
 - Under-voltage lockout (UVLO)
 - Over temperature protection
- Junction temperature range: -40°C to $+125^{\circ}\text{C}$
- Available in a exposed pad 16-pin TSSOP package

Applications

- Architectural lighting
- Industrial lighting
- Signage
- Landscape lighting (garden/pathway)
- Under cabinet lighting
- MR-16 bulbs

Typical Application

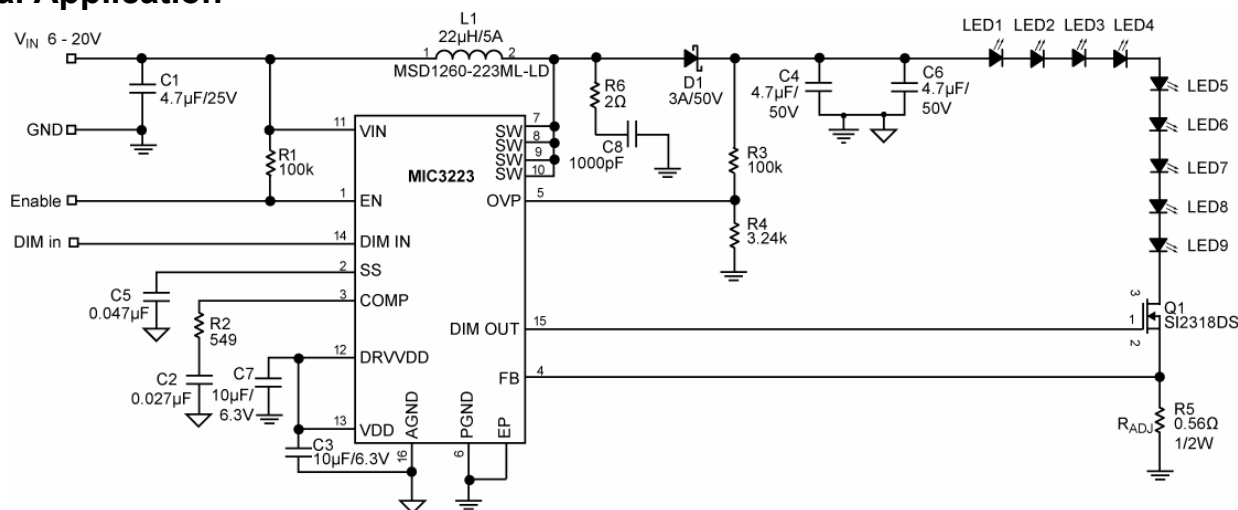

Ordering Information

Part Number	Junction Temp. Range	Package	Lead Finish
MIC3223YTSE	-40° to +125°C	16-pin ePad TSSOP	PB- free

Pin Configuration

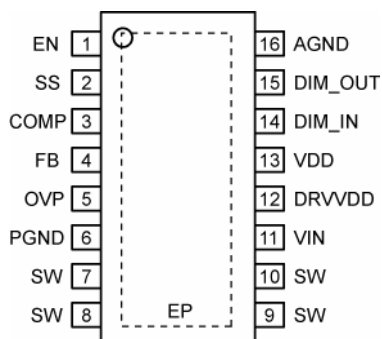

16-Pin ePad TSSOP (TSE)

Pin Description

Pin Number	Pin Name	Pin Function
1	EN	Enable (Input): Logic high enables and logic low disables operation.
2	SS	Soft Start (Input resistance of 30k). Connect a capacitor to GND for soft-start. Clamp the pin to a known voltage to control the internal reference voltage and hence the output current.
3	COMP	Compensation Pin (Input): Add external R and C-to-GND to stabilize the converter.
4	FB	Negative Input to Error Amp
5	OVP	Connect to the centre tap of an external resistor divider, the top of which is tied to Vout and bottom-to-ground.
6	PGND	Power Ground
7,8,9,10	SW	Switch Node (Input): Internal NMOS switch Drain Pin
11	VIN	Input Supply
12	DRVVDD	For 4.5V < VIN < 6V, connect DRVVDD to VIN. DRVVDD is the input voltage supply for the converter's internal power FET gate driver. For VIN > 6V, connect this pin to VDD.
13	VDD	For 4.5V < VIN < 6V, this pin becomes the input voltage supply for the converter's internal circuit. For VIN > 6V, this pin is an output of the internal 5.5V regulator that supplies internal circuits. User must add 10µF decoupling capacitor from VDD-to-AGND.
14	DIM_IN	PWM input to control LED dimming.
15	DIM_OUT	Output driver to drive external FET for LED dimming.
16	AGND	Analog Ground
17	EP	Connect to Power Ground

Absolute Maximum Ratings⁽¹⁾

Supply Voltage (V_{IN})	+22V
Switch Voltage (V_{SW})	-0.3V to +42V
Regulated Voltage (V_{DD})	-0.3V to +6.5V
Dimming In Voltage (V_{DIM_IN})	-0.3V to ($V_{DD} + 0.3V$)
Dimming Out Voltage (V_{DIM_OUT})	-0.3V to ($V_{DD} + 0.3V$)
Soft-Start Voltage (V_{SS})	-0.3V to ($V_{DD} + 0.3V$)
Enable Voltage (V_{EN})	-0.3V to ($V_{IN} + 0.3V$)
Feedback Voltage (V_{FB})	-0.3V to ($V_{DD} + 0.3V$)
Switch Current (I_{SW})	Internally Limited
Comp Voltage (V_{COMP})	-0.3V to ($+V_{DD} + 0.3V$)
FET Driver Supply (V_{DRVDD})	-0.3V to +6.5V
PGND to AGND	-0.3V to +0.3V
Over Voltage Protection (V_{OVP})	-0.3V to ($V_{DD} + 0.3V$)
Peak Reflow Temperature (soldering, 10-20sec.)	260°C
Storage Temperature (T_S)	-65°C to +150°C
ESD Rating ⁽³⁾	+2kV

Operating Ratings⁽²⁾

Supply Voltage (V_{IN})	+4.5V to +20V
Switch Voltage (V_{SW})	+37V
Junction Temperature (T_J)	-40°C to +125°C
Junction Thermal Resistance	
ePad TSSOP-16L (θ_{JA})	36.5°C/W

Electrical Characteristics⁽⁴⁾

$V_{IN} = V_{EN} = 12V$; $L = 22\mu H$, $C_{IN} = 4.7\mu F$, $C_{OUT} = 2 \times 4.7\mu F$; $T_A = 25^\circ C$, **BOLD** values indicate $-40^\circ C \leq T_J \leq +125^\circ C$, unless otherwise noted.

Symbol	Parameter	Condition	Min	Typ	Max	Units
V_{IN}	Voltage Supply Range		4.5		20	V
V_{UVLO}	Under Voltage Lockout	Monitoring for V_{DD}	3	3.7	4.4	V
V_{OVP}	Over Voltage Protection		1.216	1.28	1.344	V
I_{VIN}	Quiescent Current	$V_{FB}=250mV$		2.1	5	mA
I_{SD}	Shutdown Current	$V_{EN}=0V$			10	μA
V_{FB}	Feedback Voltage	Room Temperature	190	200	210	mV
		Over Temperature	184		216	mV
I_{FB}	Feedback Input Current	$V_{FB}=200mV$		-450		nA
V_{DD}	Internal Voltage Regulator			5.3		V
D_{MAX}	Maximum Duty Cycle		85	90	95	%
	V_{DD} Line Regulation	$V_{LED}=18V$, $V_{IN}=8V$ to $16V$, $I_{LED}=350mA$		0.5		%
I_{SW}	Switch Current Limit		3.5	9	10.5	A
R_{SW}	Switch $R_{DS(on)}$ plus R_{CS}			100		m Ω
I_{SW}	Switch Leakage Current	$V_{EN}=0$, $V_{SW}=37V$		0.01	10	μA
V_{EN}	Enable Threshold	Turn On	1.5			V
		Turn Off			0.4	V
I_{EN}	Enable Pin Current			20	40	μA
$V_{DIM_TH_H}$	DIM_IN Threshold High	Logic High	1.5			V
$V_{DIM_TH_L}$	DIM_IN Threshold Low	Logic Low			0.4	V
Hys	DIM_IN Hysteresis			500		mV
I_{DIM_IN}	DIM_IN Pin Current	$V_{DIM_IN} = 5V$			1	μA
T_{DR}	Dim Delay (Rising)	DIM_IN Rising		40		ns
T_{DF}	Dim Delay (Falling)	DIM_IN Falling		30		ns

Symbol	Parameter	Condition	Min	Typ	Max	Units
DIM MIN	Minimum Dimming Pulse	DIM_IN = 1μs C _{DIM_OUT} = 1.25nF DIM_OUT measured from 4V rising to 2.5 falling	0.7		1.3	μs
			0.5		1.5	μs
R _{DO}	DIM_OUT Resistance High	DIM_OUT pull up resistance I _{DIM_OUT} = +2mA		70		Ω
R _{DO}	DIM_OUT Resistance Low	Dim Out pull down resistance I _{DIM_OUT} = -2mA		40		Ω
F _{SW}	Oscillator Frequency		0.7	1	1.3	MHz
R _{SS}	Soft Start Resistance		30	46	62	kΩ
T _{SD}	Over Temperature Threshold Shutdown	Temperature rising		165		°C
		Hysteresis		10		°C

Notes

1. Exceeding the absolute maximum rating may damage the device.
2. The device is not guaranteed to function outside its operating rating.
3. Devices are ESD sensitive. Handling precautions recommended. Human body model, 1.5kΩ in series with 100pF.
4. Specification for packaged product only.

Test Circuit

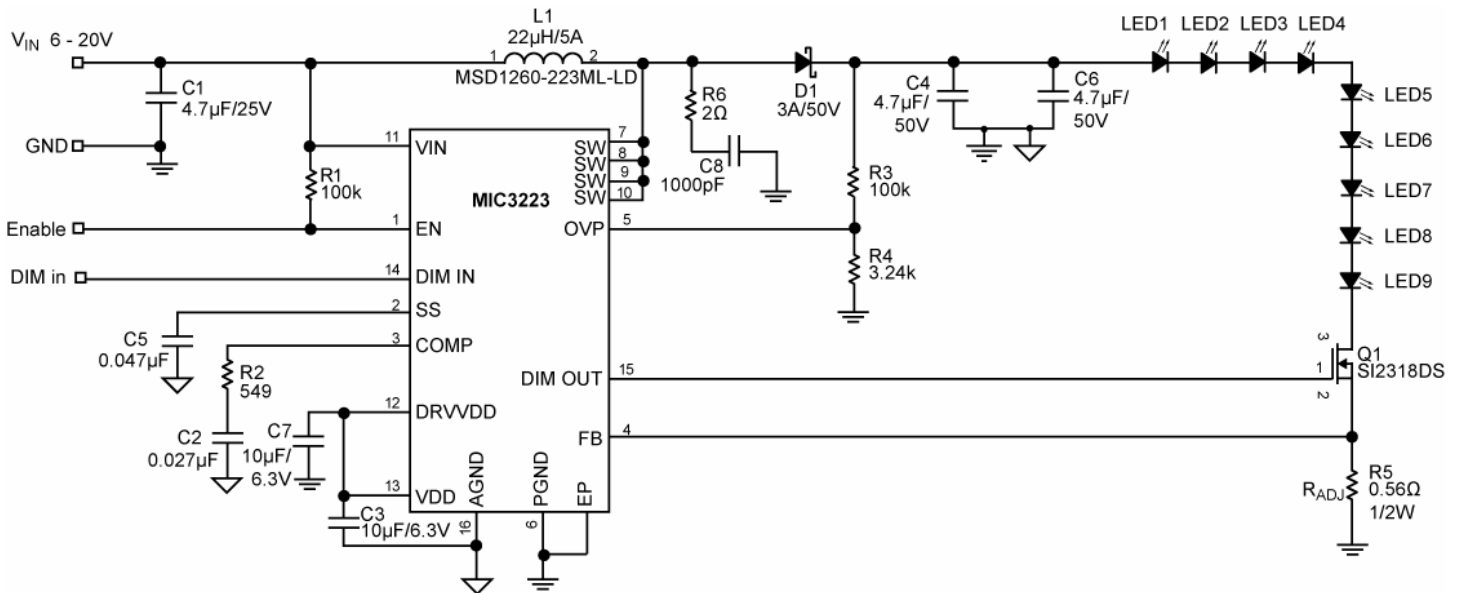

Typical Characteristics

Efficiency vs. Input Voltage

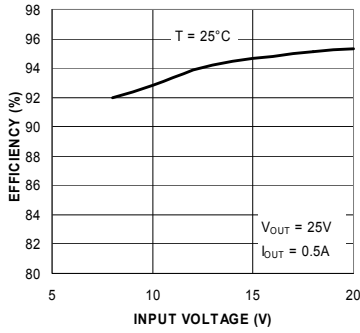

VDD Voltage vs. Input Voltage

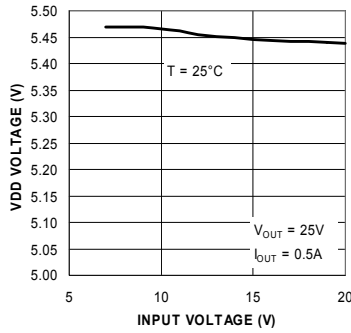

Current Limit vs. Input Voltage

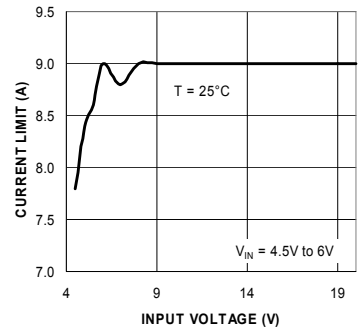

Feedback Voltage vs. Input Voltage

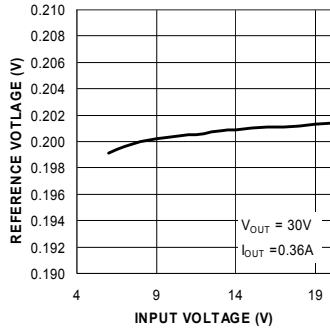

Switching Frequency vs. Input Voltage

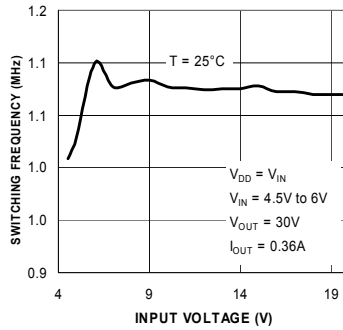

Feedback Voltage vs. Temperature

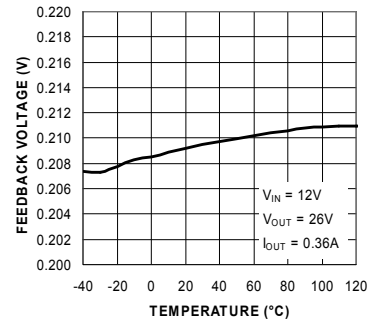

Current Limit vs. Temperature

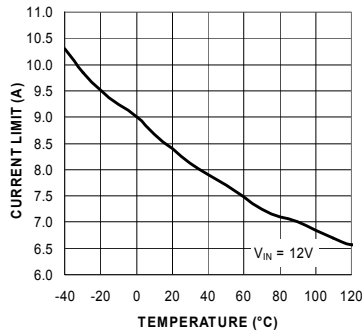

R_{SW_NODE} vs. Temperature

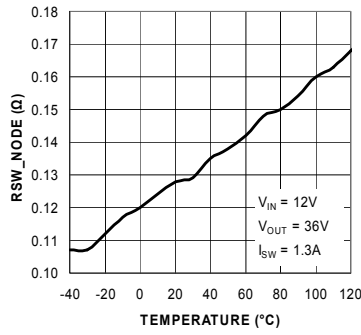

Switching Frequency vs. Temperature

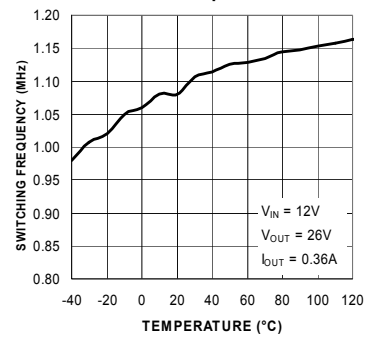

Efficiency vs. Output Current

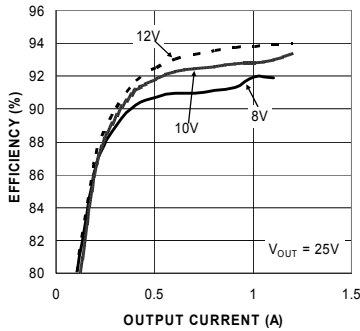

Efficiency vs. Output Current

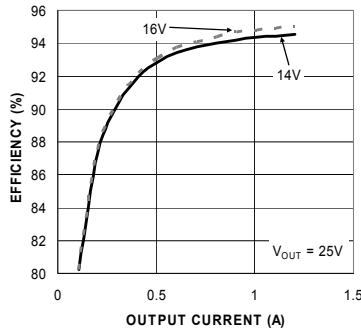

Efficiency vs. Output Current

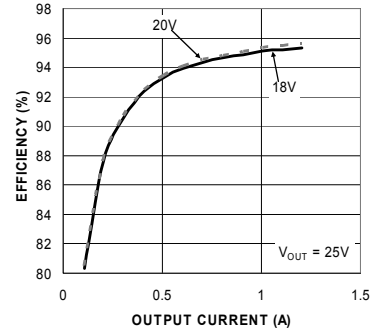

Typical Characteristics (continued)

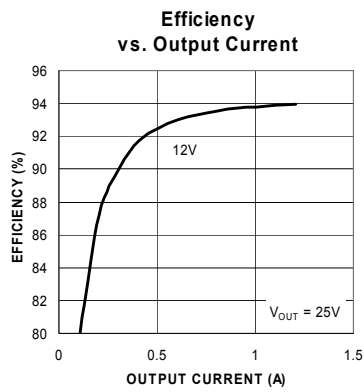
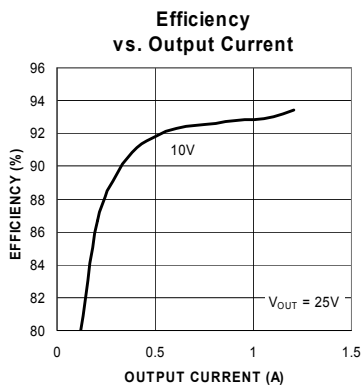

Functional Characteristics

500Hz 20% DIM IN

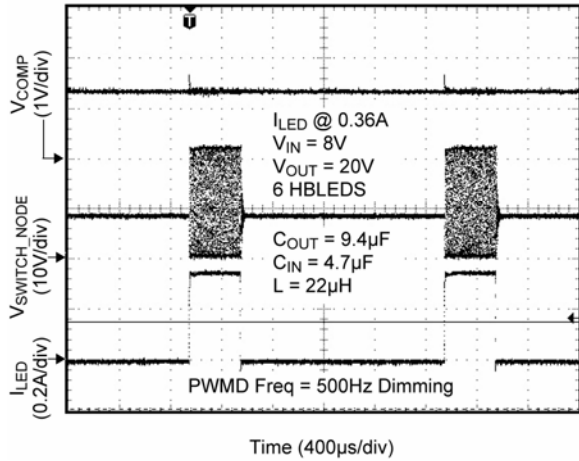

Switching Waveform

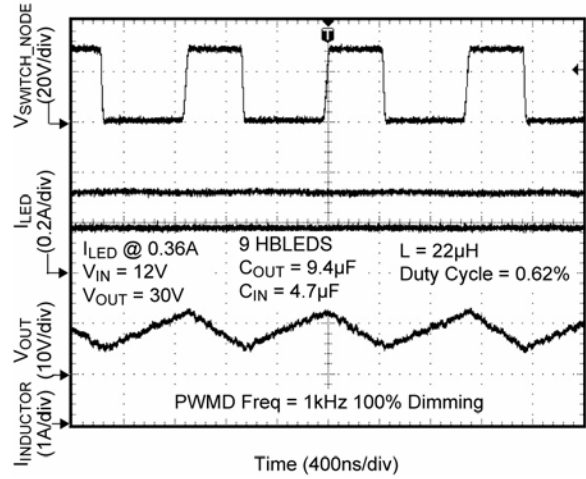

1kHz DIM IN

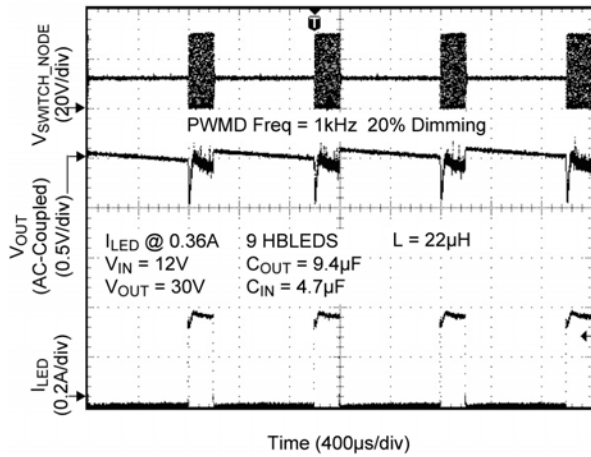

Zoom In of VOUT Droop @ 1kHz DIM IN

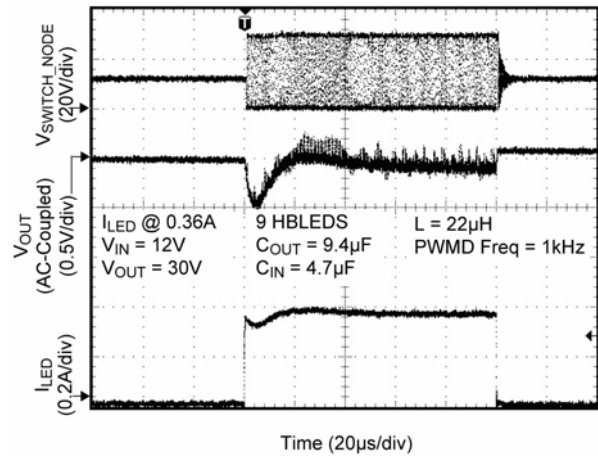

VOUT Droop @ 100Hz DIM IN

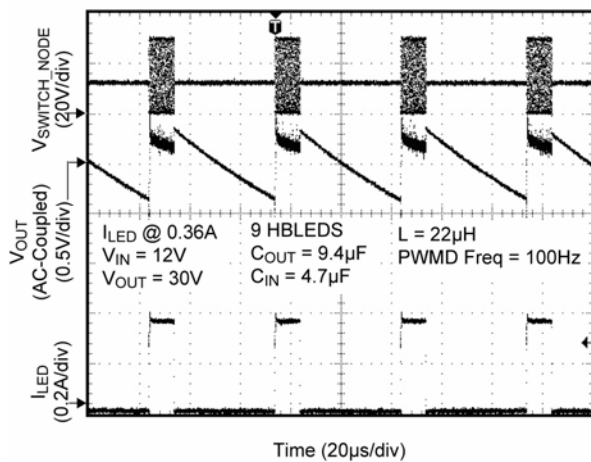

Zoom In VOUT Droop @ 100Hz DIM IN

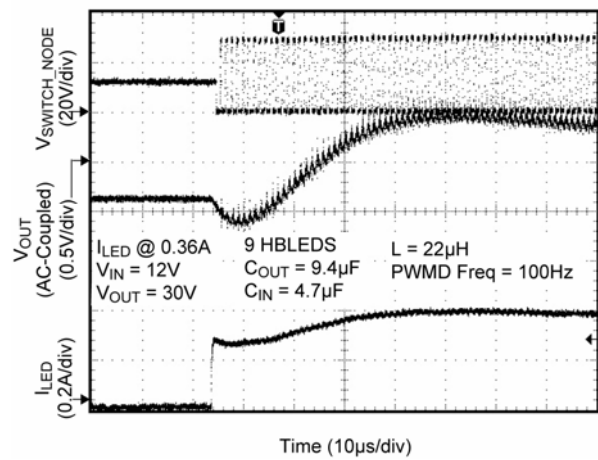

Functional Characteristics (continued)

Enable Turn-On

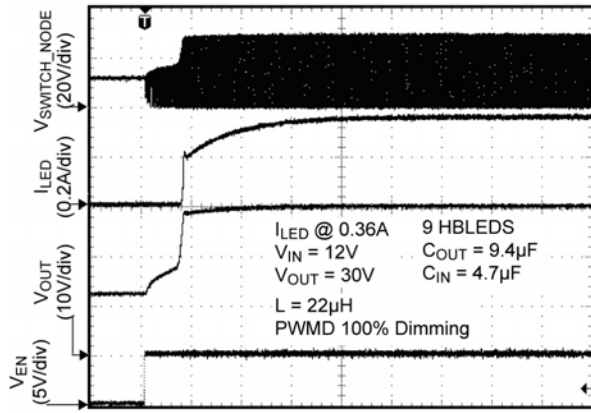

Time (2ms/div)

Enable Turn-Off

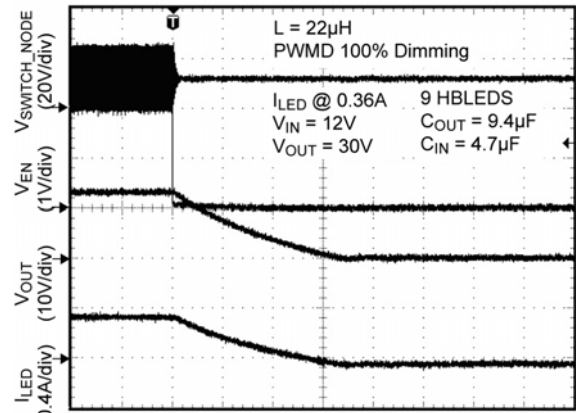

Time (1s/div)

Turn-On

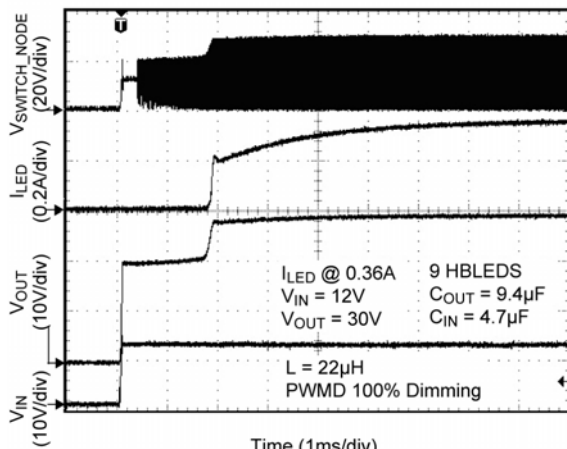

Time (1ms/div)

VIN Turn-On with $C_{IN} = 1000\mu F$

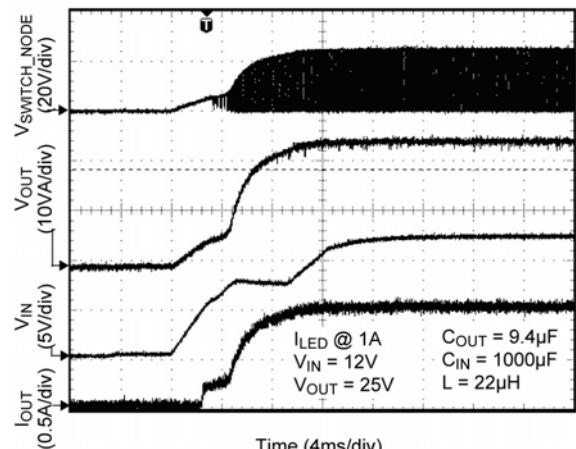

Time (4ms/div)

Current Limit

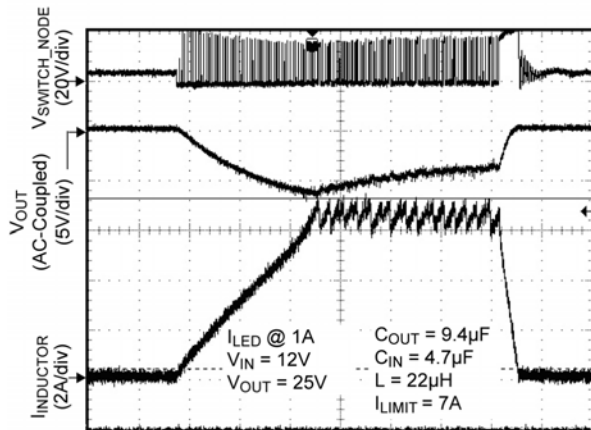

Time (20µs/div)

Functional Diagram

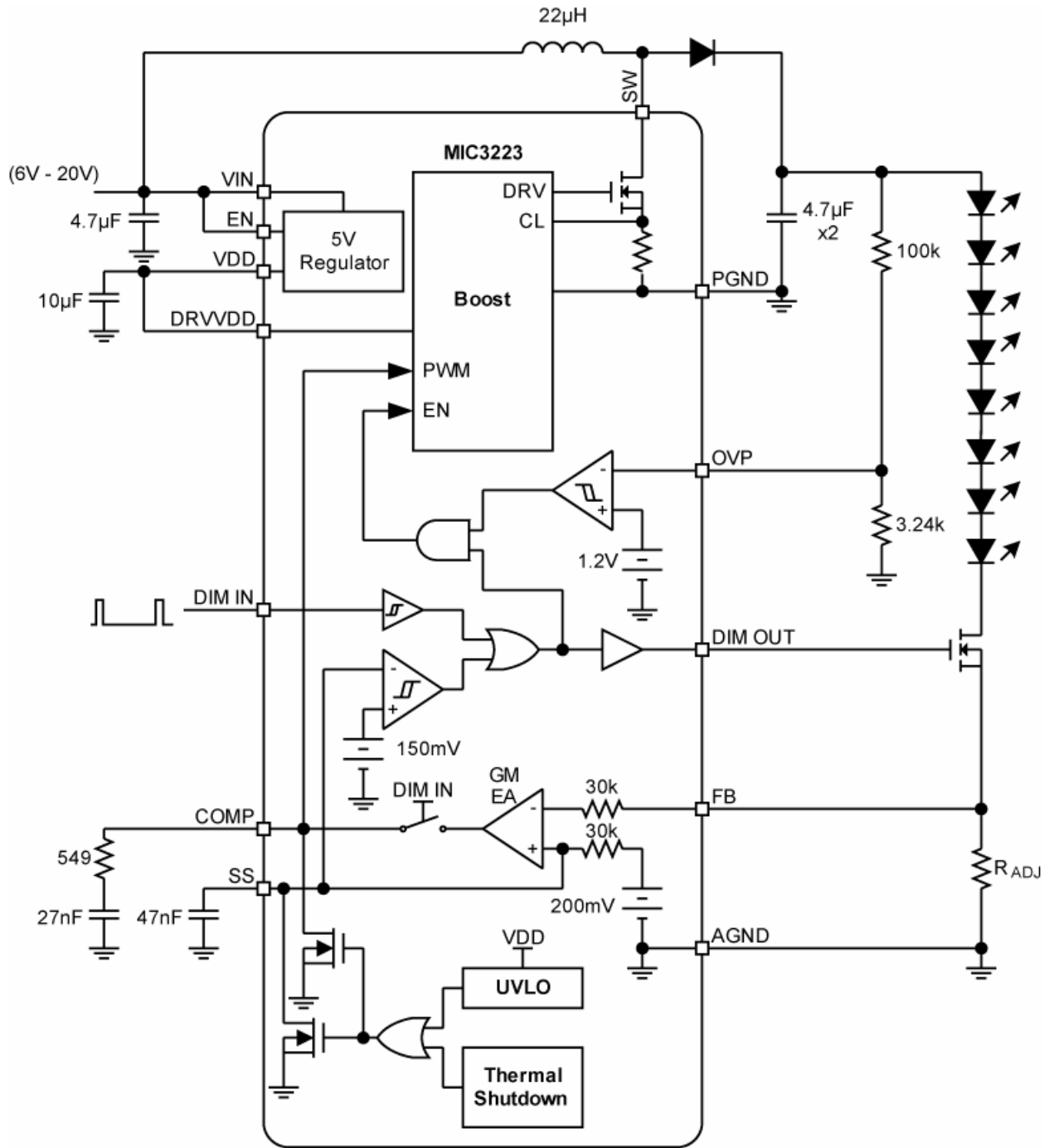

Functional Description

A constant current output converter is the preferred method for driving LEDs. Small variations in current have a minimal effect on the light output, whereas small variations in voltage have a significant impact on light output. The MIC3223 LED driver is specifically designed to operate as a constant current LED Driver.

The MIC3223 is designed to operate as a boost converter, where the output voltage is greater than the input voltage. This configuration allows for the design of driving multiple LEDs in series to help maintain color and brightness. The MIC3223 can also be configured as a SEPIC converter, where the output voltage can be either above or below the input voltage.

The MIC3223 has an input voltage range, from 4.5V and 20V, to address a diverse range of applications. In addition, the LED current can be programmed to a wide range of values through the use of an external resistor. This provides design flexibility in adjusting the current for a particular application need.

The MIC3223 features a low impedance gate driver capable of switching large MOSFETs. This low impedance provides higher operating efficiency.

The MIC3223 can control the brightness of the LEDs via its PWM dimming capability. Applying a PWM signal (up to 20kHz) to the DIM_IN pin allows for control of the brightness of the LEDs.

The MIC3223 boost converter employs peak current mode control. Peak current mode control offers advantages over voltage mode control in the following manner. Current mode control can achieve a superior line transient performance compared to voltage mode control and is easier to compensate than voltage mode control, thus allowing for a less complex control loop stability design. Page 9 of this datasheet shows the functional block diagram.

Boost Converter operation

The boost converter is a peak current mode pulse width modulation (PWM) converter and operates as follows. A flip-flop (FF) is set on the leading edge of the clock cycle. When the FF is set, a gate driver drives the power FET on. Current flows from V_{IN} through the inductor (L) and through the power switch and also through the current sense resistor to PGND. The voltage across the current sense resistor is added to a slope compensation ramp (needed for stability). The sum of the current sense voltage and the slope compensation voltages (called V_{CS}) is fed into the positive terminal of the PWM comparator. The other input to the PWM comparator is the error amp output (called V_{EA}). The error amp's negative input is the feedback voltage (V_{FB}). V_{FB} is the voltage across R_{ADJ} (R5). In this way the output LED

current is regulated. If V_{FB} drops, V_{EA} increases and therefore the power FET remains on longer so that V_{CS} can increase to the level of V_{EA} . The reverse occurs when V_{FB} increases.

PWM Dimming

This control process just described occurs during each DIM_IN pulse and when ever DIM_IN is high. When DIM_IN is low, the boost converter will no longer switch and the output voltage will drop. For high dimming ratios use an external PWM Dimming switch as shown in the Typical Application. When the dim pulse is on the external switch is on and circuit operates in the closed loop control mode as described. When the DIM_IN is low the boost converter does not switch and the external switch is open and no LED current can flow and the output voltage does not droop. When DIM_IN goes high the external switch is driven on and LED current flows. The output voltage remains the same (about the same) during each on and off DIM_IN pulse.

PWM Dimming can also be used in the Test Circuit in applications that do not require high dimming ratios. In the Test Circuit, the load is not removed from the output voltage between DIM_IN pulses and will therefore drain the output capacitors. The voltage that the output will discharge to is determined by the sum of the V_F (forward voltage drops of the LEDs). When V_{OUT} can no longer forward bias the LEDs, then the LED current will stop and the output capacitors will stop discharging. During the next DIM_IN pulse V_{OUT} has to charge back up before the full LED current will flow. For applications that do not require high dimming ratios.

Application Information

Constant Output Current Converter

The MIC3223 is a peak current mode boost converter designed to drive high power LEDs with a constant current output. The MIC3223 operates with an input voltage range from 4.5V to 20V. In the boost configuration, the output can be set from V_{IN} up to 37V.

The peak current mode control architecture of the MIC3223 provides the advantages of superior line transient response as well as an easier to design compensation.

The MIC3223 LED driver features a built-in soft start circuitry in order to prevent start-up surges. Other protection features include:

- Current Limit (I_{LIMIT}) – Current sensing for over current and overload protection
- Over Voltage Protection (OVP) – output over voltage protection to prevent operation above a safe upper limit
- Under Voltage Lockout (UVLO) – UVLO designed to prevent operation below a safe lower limit

Setting the LED Current

The current through the LED string is set via the value chosen for the current sense resistor R_{ADJ} which is R5 in the schematic of the Typical Application. This value can be calculated using Equation 1:

$$\text{Eq. (1)} \quad I_{LED} = \frac{0.2V}{R_{ADJ}}$$

Another important parameter to be aware of in the boost converter design is the ripple current. The amount of ripple current through the LED string is equal to the output ripple voltage divided by the LED AC resistance (R_{LED} – provided by the LED manufacturer) plus the current sense resistor R_{ADJ} . The amount of allowable ripple through the LED string is dependent upon the application and is left to the designer's discretion. The equation is shown in Equation 2.

$$\text{Eq. (2)} \quad \Delta I_{LED} \approx \frac{V_{OUT_RIPPLE}}{(R_{LED} + R_{ADJ})}$$

$$\text{Where} \quad V_{OUT_RIPPLE} = \frac{I_{LED} \times D}{C_{OUT} \times F_{SW}}$$

Reference Voltage

The voltage feedback loop the MIC3223 uses an internal voltage of 200mV with an accuracy of $\pm 5\%$. The feedback voltage is the voltage drop across the current sense resistor as shown in the Typical Application. When in regulation the voltage at V_{FB} will equal 200mV.

Output Over Voltage Protection (OVP)

The MIC3223 provides an OVP circuitry in order to protect the system from an overvoltage fault condition. This OVP threshold can be programmed through the use of external resistors (R3 and R4 in the Typical Application). A reference value of 1.245V is used for the OVP. Equation 3 can be used to calculate the resistor value for R9 to set the OVP point. Normally use 100k for R3.

$$\text{Eq. (3)} \quad R4 = \frac{R3}{(V_{OVP}/1.245) - 1}$$

VDD

An internal linear regulator is used to provide the necessary internal bias voltages. When V_{IN} is 6V or below connect the V_{DD} pin to V_{IN} . Use a 10 μ F ceramic bypass capacitor.

DRVDD

An internal linear regulator is used to provide the necessary internal bias voltages to the gate driver that drives the external FET. When V_{IN} is above 6V connect DRVDD to VDD.

When V_{IN} is 6V or below connect the DRVDD pin to V_{IN} . Use a bypass capacitor, 10 μ F ceramic capacitor.

UVLO

Internal under voltage lock out (UVLO) prevents the part from being used below a safe V_{IN} voltage. The UVLO is 3.7V. Operation below 4.5V is not recommended.

Soft Start

Soft start is employed to lessen the inrush currents during turn on. At turn on the following occurs;

1. After about 1.5ms C_{SS} will start to rise in an exponential manner according to;

$$V_{SS} = 0.2 \left(1 - e^{\frac{-t}{(37k\Omega \times C_{SS})}} \right)$$

2. According to the block diagram, V_{SS} is the ref node of the error amp. PWM switching start when V_{SS} begins to rise.
3. When the C_{SS} is fully charged, 0.2V will be at the error amp reference and steady state operation begins.
4. Design for soft-start time using the above equation.

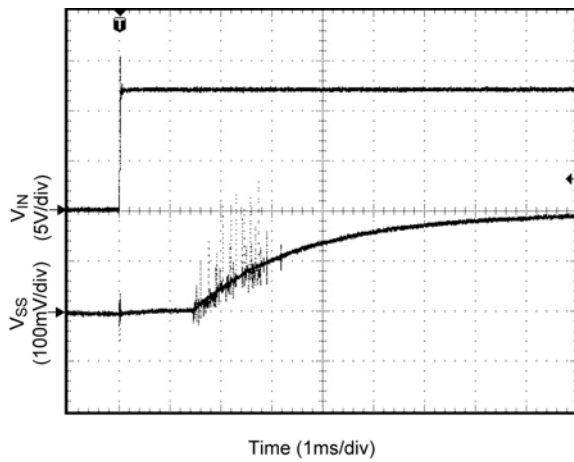

Figure 1. Soft start

LED Dimming

The MIC3223 LED driver can control the brightness of the LED string via the use of pulse width modulated (PWM) dimming. An input signal from DC up to 20kHz can be applied to the DIM_IN pin (see Typical Application) to pulse the LED string ON and OFF. It is recommended to use PWM dimming signals above 120Hz to avoid any recognizable flicker by the human eye. PWM dimming is the preferred way to dim an LED in order to prevent color/wavelength shifting. Color wavelength shifting will occur with analog dimming. By employing PWM Dimming the output current level remains constant during each DIM_IN pulse. The boost converter switches only when DIM_IN is high. Between DIM_IN pulses the output capacitors will slowly discharge. The higher the DIM_IN frequency the less the output capacitors will discharge.

PWM Dimming Limits

The minimum pulse width of the DIM_IN is determined by the DIM_IN frequency and the L and C used in the boost stage output filter. At low DIM_IN frequencies lower dimming ratios can be achieved.

$$\text{Dim_ratio} = \frac{\text{LED_ON_TIME}}{\text{PERIOD}_{\text{PWM}}}$$

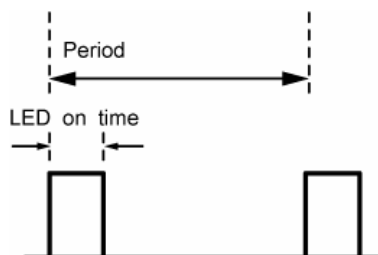

Figure 2. DIM_IN Dimming Ratio

If high dimming ratios are required, a lower Dimming frequency is required. During each DIM_IN pulse the inductor current has to ramp up to its steady state value in order for the programmed LED current to flow. The smaller the inductance value the faster this time is and a narrower DIM_IN pulse can be achieved. But smaller inductance means higher ripple current.

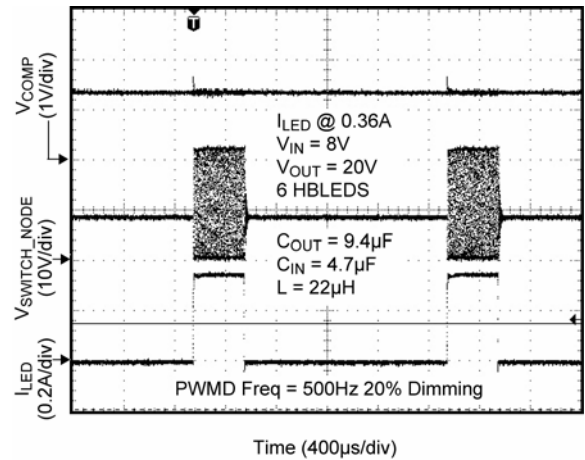

Figure 3. PWM Dimming 20%

Figure 3 shows that switching occurs only during DIM_IN on pulses. When DIM_IN is low the boost converter stops switching and the external LED is turned off. The LED current flows only when DIM_IN is high. Figure 3 shows that the compensation pin (V_{COMP}) does not discharge between DIM_IN pulses. Therefore, when the DIM_IN pulse starts again the converter resumes operation at the same V_{COMP} voltage. This eliminates the need for the comp pin to charge up during each DIM_IN pulse and allows for high Dimming ratios.

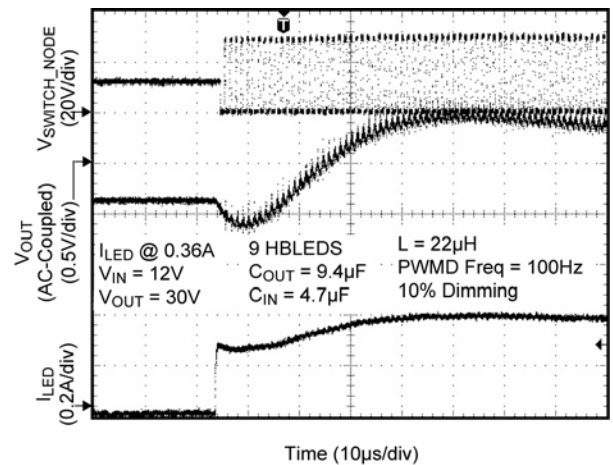

Figure 4. PWM Dimming 10% and I_{LED} 100Hz

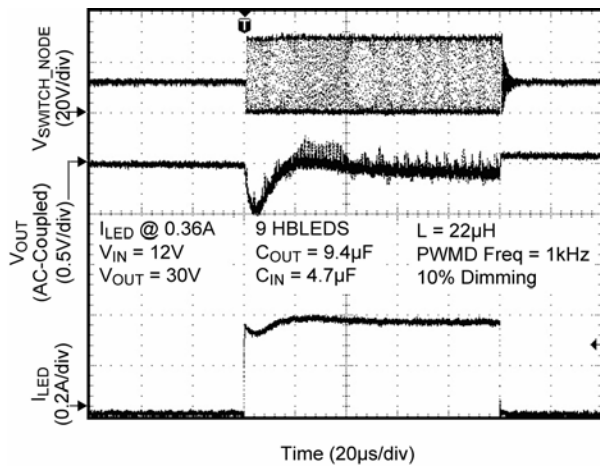

Figure 5. PWM Dimming 20% and I_{LED} 1kHz

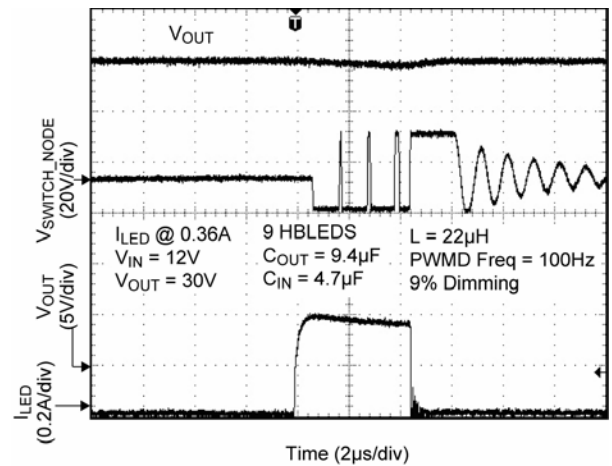

Figure 7. 5µs DIM_IN Pulse

In Figure 4 is at 100Hz dimming frequency and Figure 5 is 1kHz dimming frequency. The time it takes for the LED current to reach its full value is longer with a lower dimming frequency. The reason is the output capacitors slowly discharge between dimming pulses.

Figure 7 shows the minimum DIM_IN pulse at these operating conditions before the I_{LED} current starts to drop due to low V_{OUT} . The converter is ON (switching) only during a DIM_IN pulse.

Figure 7 shows that at this DIM_IN pulse width the converter is ON (switching) long enough to generate the necessary V_{OUT} to forward bias the LED string at the programmed current level. Therefore this condition will result in the desired I_{LED} .

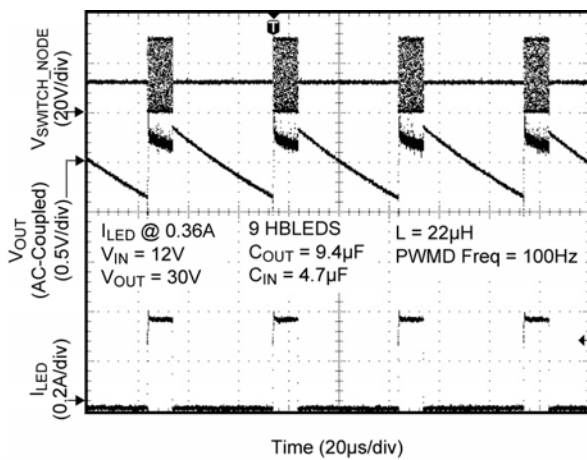

Figure 6. PWM Dimming 20% and I_{LED} 1kHz

Figure 6 shows the output voltage V_{OUT} discharge between DIM_IN pulses. The amount of discharge is dependent on the time between DIM_IN pulses.

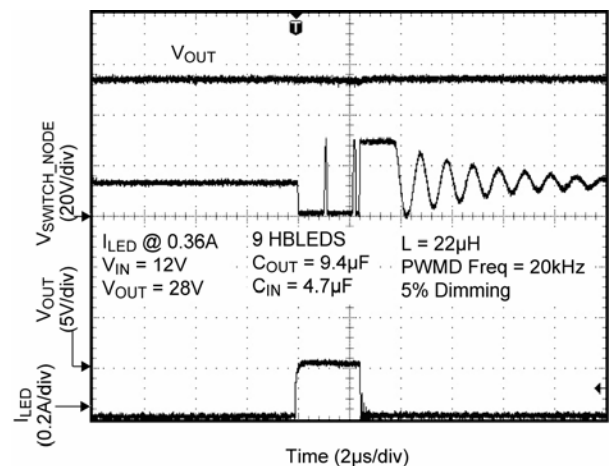

Figure 8. 2.5µs DIM_IN Pulse

Figure 8 shows that at this DIM_IN pulse width the converter is not ON (switching) long enough to generate the necessary V_{OUT} to forward bias the LED string at the programmed current level. As a result the LED current drops. Therefore, this condition will not result in the desired I_{LED} .

Design Procedure for a LED Driver

Symbol	Parameter	Min	Nom	Max	Units
Input					
V_{IN}	Input Voltage	8	12	14	V
I_{IN}	Input Current			2	A
Output					
LEDs	Number of LEDs	5	6	7	
V_F	Forward Voltage of LED	3.2	3.5	4.0	V
V_{OUT}	Output Voltage	16	21	28	V
I_{LED}	LED Current	0.33	0.35	0.37	A
I_{PP}	Required I Ripple		40		mA
Pout	Output Power			10.36	W
DIM_IN	PWM Dimming	0		100	%
OVP	Output Over Voltage Protection		30		V
System					
F_{SW}	Switching Frequency		1		MHz
eff	Efficiency		80		%
V_{DIODE}	Forward drop of schottky diode		0.5		V

Table 1. Design example parameters

Design Example

In this example, we will be designing a boost LED driver operating off a 12V input. This design has been created to drive 6 LEDs at 350mA with a ripple of about 20%. We are designing for 80% efficiency at a switching frequency of 1MHz.

Select R_{ADJ}

Having chosen the LED drive current to be 350mA in this example, the current can be set by choosing the R_{ADJ} resistor from Equation 1:

$$R_{ADJ} = \frac{0.2V}{0.35A} = 0.57\Omega$$

Use the next lowest standard value 0.56Ω.

$$I_{LED} = 0.36A$$

The power dissipation in this resistor is:

$$P_{RADJ} = I_{LED}^2 \times R_{ADJ} = 71mW$$

Use a resistor rated at quarter watt or higher.

Operating Duty Cycle

The operating duty cycle can be calculated using Equation four provided below:

$$Eq. (4) \quad D = \frac{(V_{OUT} - V_{IN} + V_{DIODE})}{V_{OUT} + V_{DIODE}}$$

V_{DIODE} is the V_f of the output diode D1 in the Typical Application. It is recommended to use a schottky diode because it has a lower V_f than a junction diode.

These can be calculated for the nominal (typical) operating conditions, but should also be understood for the minimum and maximum system conditions as listed below.

$$D_{nom} = \frac{(V_{OUT(nom)} - V_{IN(nom)} + V_{DIODE})}{V_{OUT(nom)} + V_{DIODE}}$$

$$D_{max} = \frac{(V_{OUT(max)} - V_{IN(min)} + V_{DIODE})}{V_{OUT(max)} + V_{DIODE}}$$

$$D_{min} = \frac{(V_{OUT(min)} - V_{IN(max)} + V_{DIODE})}{V_{OUT(min)} + V_{DIODE}}$$

$$D_{nom} = \frac{(21 - 12 - 0.5)}{21 + 0.5} = 0.44$$

$$D_{nom} = \frac{(21 - 12 + 0.5)}{21 + 0.5} = 0.44$$

Therefore D_{nom} = 44%, D_{max} = 72% and D_{min} = 15%.

Inductor Selection

First calculate the RMS input current (nominal, min and max) for the system given the operating conditions listed in the design example table. The minimum value of the RMS input current is necessary to ensure proper operation.

Using Equation 5, the following values have been calculated:

$$I_{IN_RMS(max)} = \frac{V_{OUT(max)} \times I_{OUT(max)}}{eff \times V_{IN(min)}} = 1.54A_{(RMS)}$$

$$Eq (5) \quad I_{IN_RMS(nom)} = \frac{V_{OUT(nom)} \times I_{OUT(nom)}}{eff \times V_{IN(nom)}} = 0.74A_{(RMS)}$$

$$I_{IN_RMS(min)} = \frac{V_{OUT(min)} \times I_{OUT(min)}}{eff \times V_{IN(max)}} = 0.46A_{(RMS)}$$

I_{OUT} is the same as I_{LED}.

Selecting the inductor current (peak-to-peak), I_{L_PP}, to be between 20% to 50% of I_{IN_RMS(nom)}, in this case 40%, we obtain:

$$I_{L_PP(nom)} = 0.4 \times I_{IN_RMS(nom)} = 0.4 \times 0.74 = 0.30A_{P-P}$$

It can be difficult to find large inductor values with high saturation currents in a surface mount package. Due to this, the percentage of the ripple current may be limited by the available inductor. It is recommended to operate in the continuous conduction mode. The selection of L described here is for continuous conduction mode.

$$Eq. (6) \quad L = \frac{V_{IN} \times D}{I_{IN_PP} \times F_{SW}}$$

Using the nominal values, we get:

$$L = \frac{12V \times 0.44}{0.3A \times 1MHz} = 18\mu H$$

Select the next higher standard inductor value of 22μH.

Going back and calculating the actual ripple current gives:

$$I_{IN_PP(max)} = \frac{V_{IN(min)} \times D_{max}}{L \times F_{SW}} = \frac{8V \times 0.72}{22\mu H \times 1MHz} = 0.26A_{PP}$$

The average input current is different than the RMS input current because of the ripple current. If the ripple current is low, then the average input current nearly equals the RMS input current. In the case where the average input current is different than the RMS, equation 7 shows the following:

$$Eq. (7) \quad I_{IN_AVE(max)} = \sqrt{(I_{IN_RMS(max)})^2 - \frac{(I_{IN_PP})^2}{12}}$$

$$I_{IN_AVE(max)} = \sqrt{(1.54)^2 - \frac{(0.24)^2}{12}} \approx 1.54A$$

The Maximum Peak input current I_{L_PK} can found using Equation 8:

$$Eq. (8) \quad I_{L_PK(max)} = I_{IN_AVE(max)} + 0.5 \times I_{L_PP(max)} = 1.67A$$

The saturation current (I_{SAT}) at the highest operating temperature of the inductor must be rated higher than this.

The power dissipated in the inductor is:

$$\text{Eq. (9)} \quad P_{\text{INDUCTOR}} = I_{\text{IN_RMS(max)}}^2 \times \text{DCR}$$

A Coilcraft # MSS1260-223ML is used in this example. Its DCR is 52mΩ, I_{SAT} = 2.7A

$$P_{\text{INDUCTOR}} = 1.54^2 \times 52 \text{ m}\Omega = 0.123\text{W}$$

Output Capacitor

In this LED driver application, the I_{LED} ripple current is a more important factor when compared to that of the output ripple voltage (although the two are directly related). To find the C_{OUT} for a required I_{LED} ripple use the following calculation:

For an output ripple I_{LED(ripple)} = 20ma

$$\text{Eq. (10)} \quad C_{\text{OUT}} = \frac{I_{\text{LED(nom)}} \times D_{\text{nom}}}{I_{\text{LED(ripple)}} \times (R_{\text{ADJ}} + R_{\text{LED_total}}) \times F_{\text{SW}}}$$

Find the equivalent ac resistance R_{LED_ac} from the datasheet of the LED. This is the inverse slope of the I_{LED} vs. V_f curve i.e.:

$$\text{Eq. (11)} \quad R_{\text{LED_ac}} = \frac{\Delta V_f}{\Delta I_{\text{LED}}}$$

In this example use R_{LED_ac} = 0.6Ω for each LED.

If the LEDs are connected in series, multiply R_{LED_ac} = 0.6Ω by the total number of LEDs. In this example of six LEDs, we obtain the following:

$$R_{\text{LED_total}} \equiv R_{\text{dynamic}} = 6 \times 0.6\Omega = 3.6\Omega$$

Eq. (12)

$$C_{\text{OUT}} = \frac{I_{\text{LED(nom)}} \times D_{\text{nom}}}{I_{\text{LED(ripple)}} \times (R_{\text{ADJ}} + R_{\text{LED_total}}) \times F_{\text{SW}}} = 1.9\mu\text{F}$$

Use 2.2μF or higher.

There is a trade off between the output ripple and the rising edge of the DIM_IN pulse. This is because between PWM dimming pulses, the converter stops pulsing and C_{OUT} will start to discharge. The amount that C_{OUT} will discharge depends on the time between PWM Dimming pluses. At the next DIM_IN pulse, C_{OUT} has to be charged up to the full output voltage V_{OUT} before the desired LED current flows.

Input Capacitor

The input capacitor is shown in the Typical Application. For superior performance, ceramic capacitors should be used because of their low equivalent series resistance (ESR). The input capacitor C_{IN} ripple current is equal to the ripple in the inductor. The ripple voltage across the input capacitor, C_{IN} is the ESR of C_{IN} times the inductor ripple. The input capacitor will also bypass the EMI generated by the converter as well as any voltage spikes generated by the inductance of the input line. For a required V_{IN(ripple)}:

Eq. (13)

$$C_{\text{IN}} = \frac{I_{\text{IN_PP}}}{V_{\text{IN(ripple)}} \times F_{\text{SW}}} = \frac{(0.3\text{A})}{8 \times 50\text{mV} \times 1\text{MHz}} = 0.75\mu\text{F}$$

This is the minimum value that should be used. To protect the IC from inductive spikes or any overshoot, a larger value of input capacitance may be required.

Use 2.2μF or higher as a good safe min.

Rectifier Diode Selection

A schottky diode is best used here because of the lower forward voltage and the low reverse recovery time. The voltage stress on the diode is the max V_{OUT} and therefore a diode with a higher rating than max V_{OUT} should be used. An 80% de-rating is recommended here as well.

$$\text{Eq. (14)} \quad I_{\text{DIODE(max)}} = I_{\text{OUT(max)}} = 0.36\text{A}$$

Since I_{IN_AVE(max)} occurs when D is at a maximum.

$$\text{Eq. (15)} \quad P_{\text{DIODE(max)}} \approx V_{\text{DIODE}} \times I_{\text{DIODE(max)}}$$

A SK35B is used in this example, it's V_{DIODE} is 0.5V

$$P_{\text{DIODE(max)}} \approx 0.5\text{V} \times 0.36\text{A} = 0.18\text{W}$$

MIC3223 Power Losses

To find the power losses in the MIC3223:

There is about 6mA input from V_{IN} into the V_{DD} pin.

The internal power switch has an R_{DS_ON} of about 170mΩ at.

$$P_{\text{MIC3223}} = V_{\text{IN}} \times 6\text{mA} + P_{\text{wrFET}}$$

$$\text{Eq. (16)} \quad P_{\text{wrFET}} = I_{\text{FET_RMS(max)}}^2 \times R_{\text{ds_on_@100}^\circ} + V_{\text{OUT(max)}} \times I_{\text{IN_AVE(max)}} \times t_{\text{sw}} \times F_{\text{sw}}$$

$$R_{\text{ds_on_@100}^\circ} \approx 160\text{m}\Omega$$

t_{sw} ≈ 30ns is the internal Power FET ON an OFF transition time.

$$I_{\text{SW_RMS(max)}} = \sqrt{D \left(I_{\text{IN_AVE(max)}}^2 + \frac{I_{\text{L_PP}}^2}{12} \right)} = 1.3\text{A}$$

$$P_{\text{wrFET}} = 1.3\text{A}^2 \times 160\text{m}\Omega + 28\text{V} \times 1.54\text{A} \times 30\text{ns} \times 1\text{MHz} = 1.6\text{W}$$

$$P_{\text{MIC3223}} = 8 \times 6\text{mA} + 1.77\text{W} = 1.66\text{W}$$

Snubber

A snubber is a damping resistor in series with a DC blocking capacitor in parallel with the power switch (same as across the flyback diode because V_{OUT} is an ac ground). When the power switch turns off, the drain to source capacitance and parasitic inductance will cause a high frequency ringing at the switch node. A snubber circuit as shown in the application schematic may be required if ringing is present at the switch node. A critically damped circuit at the switch node is where R equals the characteristic impedance of the switch node.

$$\text{Eq. (17)} \quad R_{\text{snubber}} = \sqrt{\frac{L_{\text{parasitic}}}{C_{\text{ds}}}}$$

The explanation of the method to find the best R snubber is beyond the scope of this data sheet.

Use $R_{\text{snubber}} = 2\Omega$, ½ watt and $C_{\text{snubber}} = 470\text{pf}$ to 1000pf .

The power dissipation in the R_{snubber} is:

$$P_{\text{snubber}} = C_{\text{snubber}} \times V_{\text{OUT}}^2 \times F_{\text{SW}}$$

$$P_{\text{snubber}} = 470\text{pF} \times 28\text{V}^2 \times 1\text{MHz} = 0.4\text{W}$$

Power Loss in the L	0.123 W
Power Loss in the sckottky diode	0.2 W
P_{snubber}	0.4 W
MIC3223 Power Loss	1.66 W
Total Losses	2.4W
Efficiency	80%

Table 2. Major Power Losses

Table 2 showing the Power losses in the Design Example.

OVP - Over Voltage Protection

Set OVP higher than the maximum output voltage by at least one Volt. To find the resistor divider values for OVP use equation 18 and set the OVP = 30V and $R_{\text{OVP_H}} = 100\text{k}\Omega$:

$$\text{Eq. (18)} \quad R_{\text{OVP_L}} = \frac{100\text{k}\Omega \times 1.245}{30 - 1.245} = 4.33\text{k}\Omega$$

Compensation

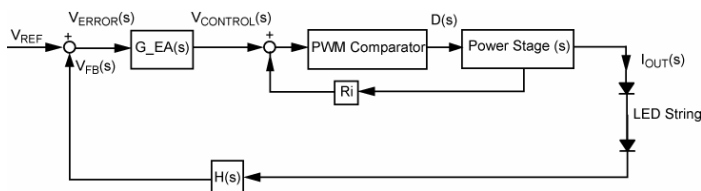

Figure 9. Current Mode Loop Diagram

Current mode control simplifies the compensation. In current mode, the complex poles created by the output L and C are reduced to a single pole. The explanation for this is beyond the scope of this datasheet, but it's generally thought to be because the inductor becomes a constant current source and can't act to change phase.

From the small signal block diagram the loop transfer function is:

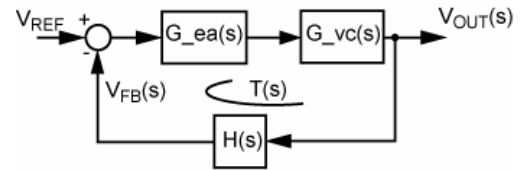

Figure 10. Simplified Control Loop

$$\text{Eq. (19)} \quad T(s) = G_{\text{ea}}(s) \times G_{\text{vc}}(s) \times H(s)$$

Where

For a LED driver $H(s) = \frac{R_{\text{ADJ}}}{R_{\text{ADJ}} + R_{\text{dynamic}}}$ and

$$G_{\text{ea}}(s) = g_m \left(Z_O \parallel \left(R_{\text{comp}} + \frac{1}{sC_{\text{comp}}} \right) \right)$$

Eq. (20)

$$G_{\text{VC}}(s) = \frac{V_{\text{OUT}}(s)}{V_{\text{CONTROL}}(s)}$$

$$= \left(\frac{1}{R_i} \right) \left(\frac{D'R_{\text{OP}}}{2} \right) \frac{\left(1 - \frac{sL}{D'^2 R_{\text{dynamic}}} \right) (1 + sC_{\text{OUT}}R_{\text{ESR}})}{\left(1 + \frac{sR_{\text{dynamic}}C_{\text{OUT}}}{2} \right)}$$

Where

$R_{\text{OP}} = \frac{V_{\text{OUT}}}{I_{\text{LED}}}$ Is the DC operating point of the converter.

R_{dynamic} is the ac load the converter sees. When the load on the converter is a string of LEDs, R_{dynamic} is the series sum of the $R_{\text{LED(ac)}}$ of each LED.

$R_{\text{LED_total}}$ is usually between 0.1Ω to 1Ω per LED. It can be calculated from the slope of I_{LED} vs. V_f plot of the LED.

$$R_i = A_i \times R_{\text{cs}} = 0.86\Omega$$

$A_i = 114$ and $R_{\text{cs}} \approx 7.5\text{m}\Omega$; are internal to the ic.

The equation for $G_{\text{vc}}(s)$ is theoretical and should give a good idea of where the poles and zeros are located.

$$\text{Eq. (20) shows that } s = \frac{D'^2 R_{\text{dynamic}}}{L} \rightarrow f_{\text{RHPZ}} = \frac{D'^2 R_{\text{dynamic}}}{2\pi L}$$

is a RHP Zero. The loop bandwidth should be about 1/5 to 1/10 of the frequency of R_{HPZ} to ensure stability. From Equation (20) it is shown that there is only the single pole.

$$s = \frac{1}{R_{\text{dynamic}}C_{\text{OUT}}} \rightarrow f_{\text{pole}} = \frac{1}{2\pi R_{\text{dynamic}}C_{\text{OUT}}}$$

and a Zero due to the ESR of the output capacitor.

$$s = \frac{1}{R_{\text{ESR}}C_{\text{OUT}}} \rightarrow f_{\text{ESR}} = \frac{1}{2\pi R_{\text{ESR}}C_{\text{OUT}}}$$

This greatly simplifies the compensation.

One needs only to get a bode plot of the transfer function of the control to output $G_{vc}(s)$ with a network analyzer and/or calculate it. From the bode plot find what the gain of

$G_{vc}(s)$ is at $f = \frac{R_{HPZ}}{10}$. Next design the error amp gain

$G_{ea}(s)$ so the loop gain at the cross over frequency $T(f_{co})$ is

0 db where $f_{co} = \frac{R_{HPZ}}{10}$ or less.

Error Amp

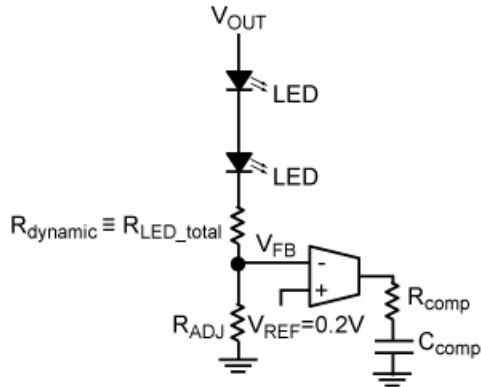

Figure 11. Internal Error Amp and External Compensation

The error amp is a gm type and the gain $G_{ea}(s)$ is

$$\text{Eq. (21)} \quad G_{ea}(s) = g_m \left(Z_o \parallel \left(R_{comp} + \frac{1}{sC_{comp}} \right) \right)$$

$$g_m = \frac{0.8\text{mA}}{V} \text{ and } Z_o = 1.2\text{M}\Omega.$$

$$\text{The zero is } f_{zero} = \frac{1}{2R_{comp}C_{comp}} = \frac{f_{co}}{10} = \frac{R_{HPZ}}{100}.$$

Error Amp Gain and Phase

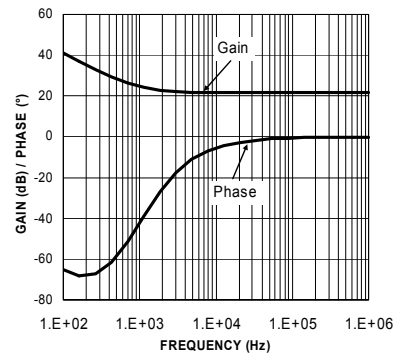

Set the f_{co} at the mid band where $G_{ea}(f_{co}) = g_m \times R_{comp}$. At $f_{zero} \times 10$ the phase boost is near its maximum.

Figure 12. Error Amp Transfer Function

Other Applications

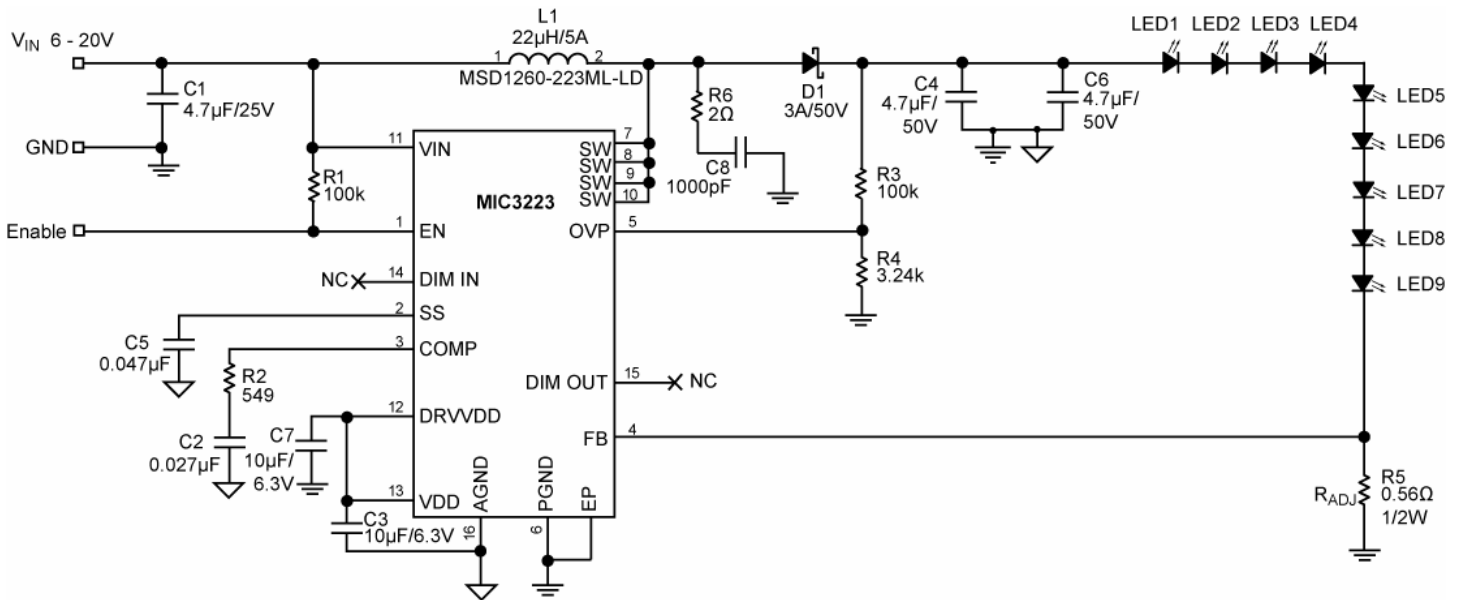

Figure 13. MIC3223 Typical Application without External PWM Dimming Switch

Audio noise

Audio noise from the output capacitors may exist in a standard boost LED converter. The physical dimensions of ceramic capacitors change with the voltage applied to them. During PWM Dimming, the output capacitors in standard converters are subjected to fast voltage and current transients that may cause the output capacitors to oscillate at the PWM Dimming frequency. This is one reason users may want PWM dimming frequencies above the audio range.

PCB Layout

1. All typologies of DC-to-DC converters have a Reverse Recovery Current (RRC) of the flyback or (freewheeling) diode. Even a Schottky diode, which is advertised as having zero RRC, it really is not zero. The RRC of the freewheeling diode in a boost converter is even greater than in the Buck converter. This is because the output voltage is higher than the input voltage and the diode has to charge up to $-V_{OUT}$ during each on-time pulse and then discharge to V_f during the off-time.

2. Even though the RRC is very short (tens of nanoseconds) the peak currents are high (multiple amperes). These fast current spikes generate EMI (electromagnetic interference). The amount of RRC is related to the die size and internal capacitance of the diode. It is important not to oversize (i.e. not more than the usual derating) the diode because the RRC will be needlessly higher. Example: If a 2A diode is needed do not use a higher current rated diode because the RRC will be needlessly higher. If a 25V diode is needed do not use a 100V etc.
3. The high RRC causes a voltage drop on the ground trace of the PCB and if the converter control IC is referenced to this voltage drop, the output regulation will suffer.
4. For good output regulation, it is important to connect the IC's reference to the same point as the output capacitors to avoid the voltage drop caused by RRC. This is also called a star connection or single point grounding.
5. Feedback trace: The high impedance traces of the FB should be short.

Evaluation Board Schematic

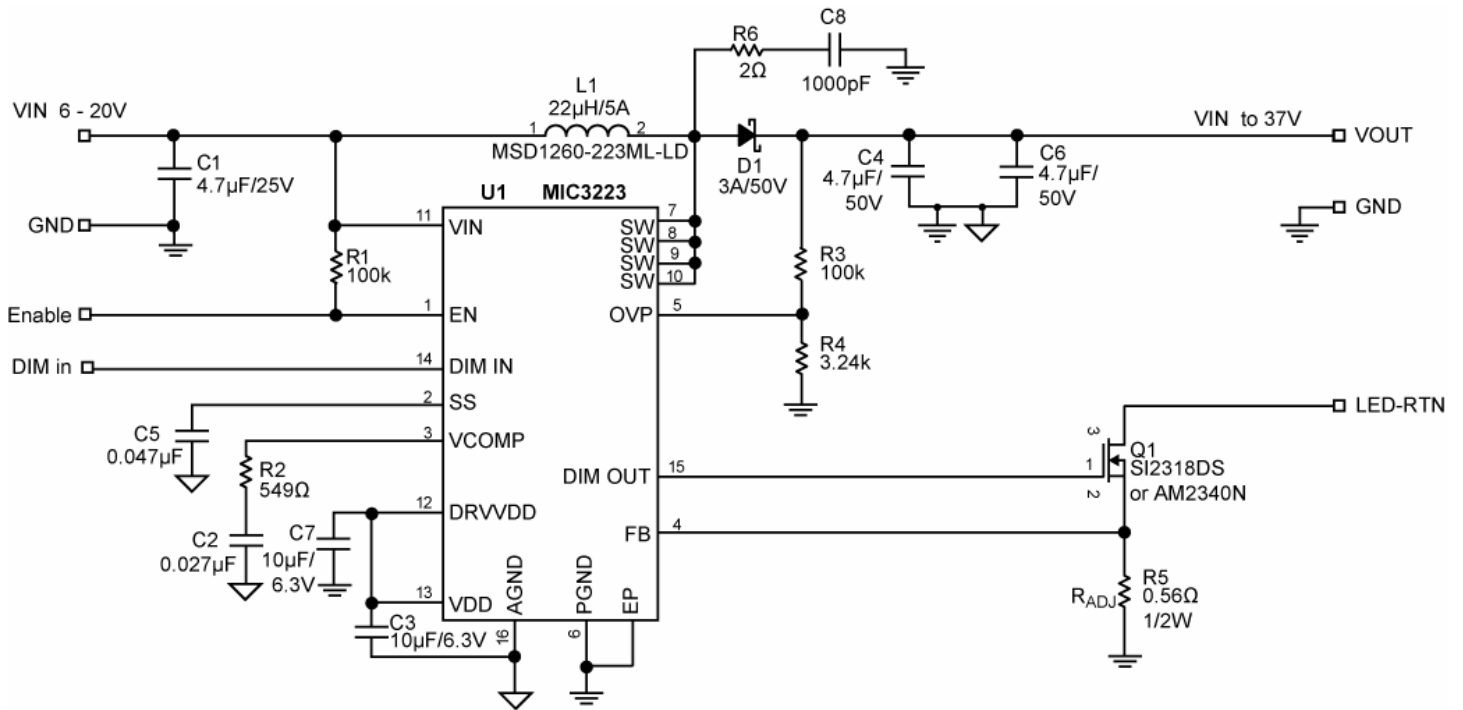

37V Max 1A LED Driver

Bill of Materials

Item	Part Number	Manufacturer	Description	Qty
C1	GRM319R61E475KA12D	muRata ⁽¹⁾	Ceramic Capacitor, 4.7 μ F, 25V, Size 1206, X7R	1
	C3216X7R1E475M	TDK ⁽²⁾		
	12063D475KAT2A	AVX ⁽³⁾		
C2	GRM188R71C273KA01D	muRata	Ceramic Capacitor, 0.027 μ F, 6.3V, Size 0603, X7R	1
C3, C7	GRM188R60J106ME47D	muRata	Ceramic Capacitor, 10 μ F, 6.3V, Size 0603, X7R	2
	C1608X5R0J106K	TDK		
	08056D106MAT2A	AVX		
C4, C6	12105C475KAZ2A	AVX	Ceramic Capacitor, 4.7 μ F, 50V, Size 1210, X7R	2
	GRM32ER71H475KA88L	muRata		
C5	GRM188R71C473KA01D	muRata	Ceramic Capacitor, 0.047 μ F, 6.3V, Size 0603, X7R	1
	0603YC473K4T2A	AVX		
C8	GRM188R72A102KA37D	muRata	Ceramic Capacitor, 1000pF, 100V Size 0603, X7R	
D1	SK35B	MCC ⁽⁴⁾	Schottky Diode, 3A, 50V (SMB)	1
L1	MSD1260-223ML-LD	Coilcraft ⁽⁶⁾	Inductor, 22 μ H, 5A	1
R1, R3	CRCW0603100KFKEA	Vishay Dale ⁽⁴⁾	Resistor, 100k, 1%, Size 0603	2
R2	CRCW0603549RFKEA	Vishay Dale	Resistor, 549 Ω , 1%, Size 0603	1
R4	CRCW06033K24FKEA	Vishay Dale	Resistor, 3.24k, 1%, Size 0603	1
R5	CRCW1206R560FKEA	Vishay Dale	Resistor, 0.56 Ω , 1%, 1/2W, Size 1206 (for .35A LED current Change for different ILED)	1
R6	RMC 1/4 2 1% R	Stackpole Electronics, Inc. ⁽⁷⁾	Resistor, 2 Ω , 1%, 1/2W, Size 1210	1
Q1	Si2318DS	Vishay Siliconix ⁽⁴⁾	N-Channel 40V MOSFET	1
	AM2340N	Analog Power ⁽⁸⁾		
U1	MIC3223	Micrel, Inc.⁽⁹⁾	High Power Boost LED Driver with Integrated FET	1

Notes:

1. Murata: www.murata.com.
2. TDK: www.tdk.com.
3. AVX: www.avx.com.
4. Vishay: www.vishay.com.
5. Internacional Rectifier: www.ift.com.
6. Coilcraft: www.coilcraft.com
7. Stackpole Electronics, Inc.: [www](http://www.stackpole.com).
8. Analog Power: www.analogpowerinc.com
8. **Micrel, Inc.:** www.micrel.com.

PCB Layout Recommendations

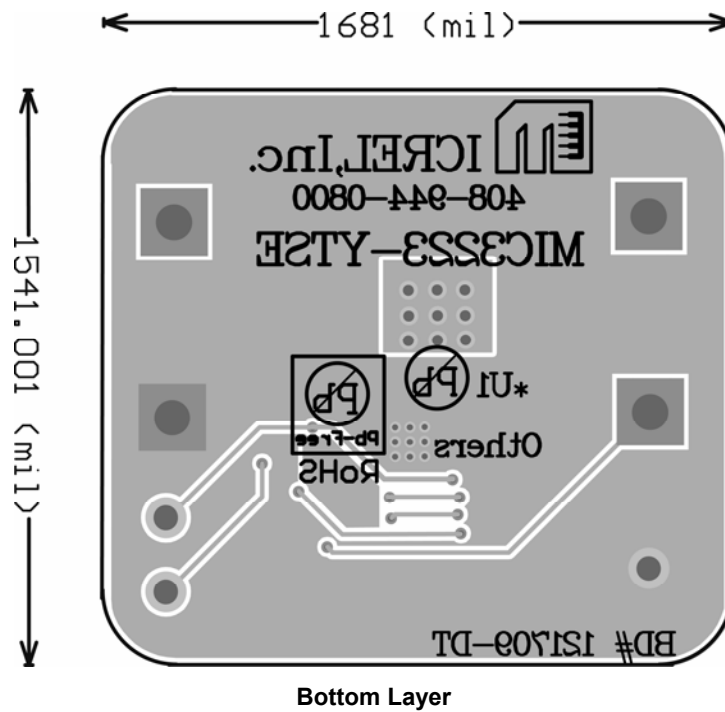
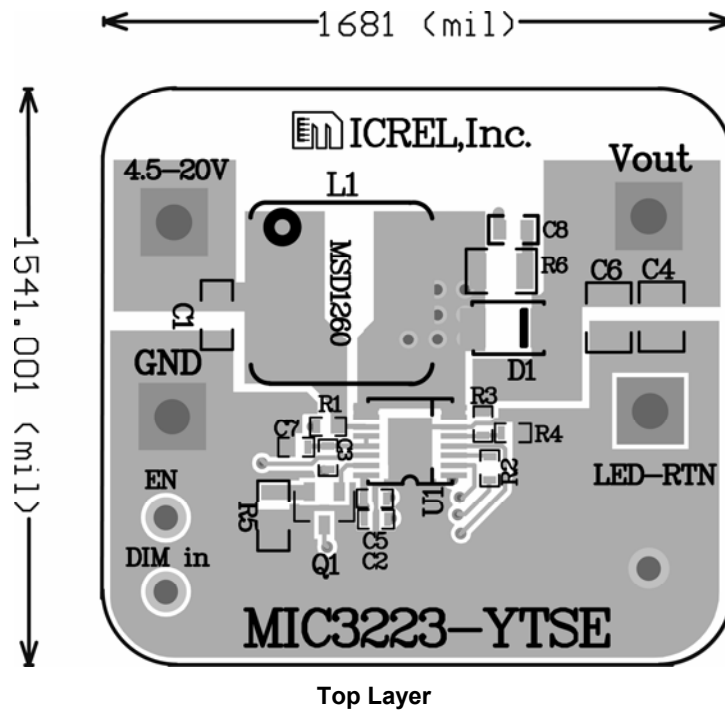

Package Information

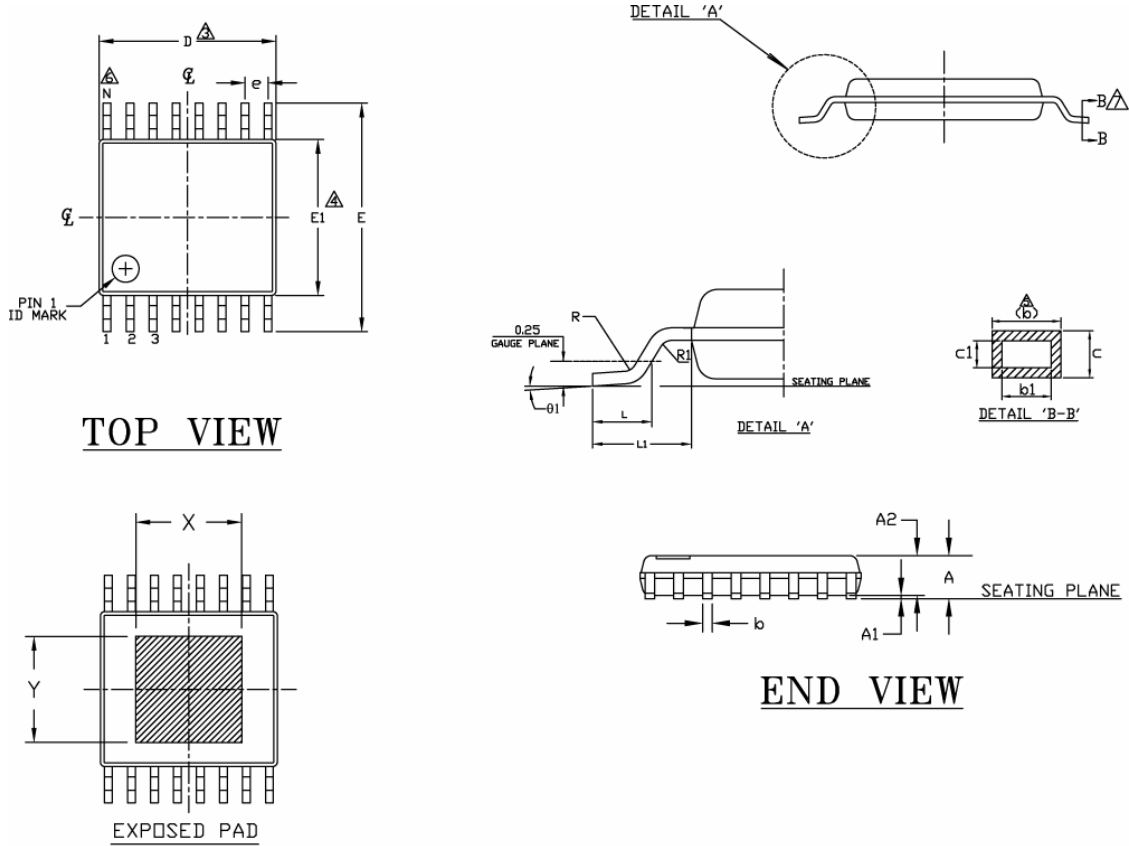

TOP VIEW

END VIEW

BOTTOM VIEW

SYMBOL	14L TSSOP Thermally Enhanced			16L TSSOP Thermally Enhanced		
	MIN	NOM.	MAX	MIN	NOM.	MAX
A	—	—	1.20	—	—	1.20
A1	0.025	—	0.100	0.025	—	0.100
A2	0.80	0.90	1.05	0.80	0.90	1.05
D	4.9	5.0	5.1	4.9	5.0	5.1
E1	4.3	4.4	4.5	4.3	4.4	4.5
E	6.2	6.4	6.6	6.2	6.4	6.6
L	0.45	0.60	0.75	0.45	0.60	0.75
R	0.09	—	—	0.09	—	—
R1	0.09	—	—	0.09	—	—
b	0.19	—	0.30	0.19	—	0.30
b1	0.19	0.22	0.25	0.19	0.22	0.25
c	0.09	—	0.20	0.09	—	0.20
c1	0.09	—	0.16	0.09	—	0.16
Ø1	0*	—	8*	0*	—	8*
L1	1.0 REF			1.0 REF		
e	0.65 BSC			0.65 BSC		
N	14			16		
Ref.	Jedec MO-153 Issue C Variation ABT-1			Jedec MO-153 Issue C Variation ABT		
EP Area	Pad Size Up 1	X 2.997	Y 3.200	Pad Size Up 1	X 2.997	Y 2.997

Notes

1. ALL DIMENSIONS ARE IN MILLIMETERS (ANGLES IN DEGREES).
2. DIMENSIONING AND TOLERANCING PER ANSI Y14.5M-1982.
3. DIMENSION 'D' DOES NOT INCLUDE MOLD FLASH, PROTRUSIONS OR GATE BURRS.
4. DIMENSION 'E1' DOES NOT INCLUDE INTERNAL FLASH OR PROTRUSION.
5. DIMENSION 'b' DOES NOT INCLUDE DAMBAR PROTRUSION.
6. DIMENSION 'N' IS THE MAXIMUM NUMBER OF LEAD TERMINAL POSITIONS FOR THE SPECIFIED PACKAGE LENGTH.
7. CROSS SECTION B-B TO BE DETERMINED AT 0.10 TO 0.25MM FROM THE LEAD TIP.
8. EXPOSED PAD WILL BE DEPEND ON THE PAD SIZE OF THE L/F.

16-Pin ePad TSSOP (TSE)

Recommended Land Pattern

LP # TSSOPEP-16LD-LP-1
 All units are in mm
 Tolerance ± 0.05 if not noted

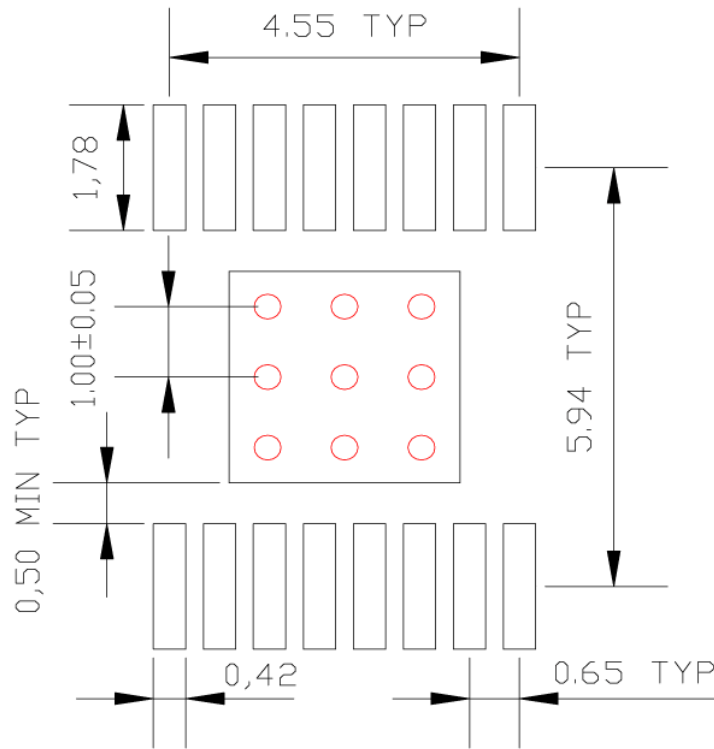

Red circle indicates Thermal Via. Size should be .300-.350 mm in diameter and it should be connected to GND plane for maximum thermal performance.

MICREL, INC. 2180 FORTUNE DRIVE SAN JOSE, CA 95131 USA
 TEL +1 (408) 944-0800 FAX +1 (408) 474-1000 WEB <http://www.micrel.com>

The information furnished by Micrel in this data sheet is believed to be accurate and reliable. However, no responsibility is assumed by Micrel for its use. Micrel reserves the right to change circuitry and specifications at any time without notification to the customer.

Micrel Products are not designed or authorized for use as components in life support appliances, devices or systems where malfunction of a product can reasonably be expected to result in personal injury. Life support devices or systems are devices or systems that (a) are intended for surgical implant into the body or (b) support or sustain life, and whose failure to perform can be reasonably expected to result in a significant injury to the user. A Purchaser's use or sale of Micrel Products for use in life support appliances, devices or systems is a Purchaser's own risk and Purchaser agrees to fully indemnify Micrel for any damages resulting from such use or sale.

© 2009 Micrel, Incorporated.



Стандарт Электрон Связь

Мы молодая и активно развивающаяся компания в области поставок электронных компонентов. Мы поставляем электронные компоненты отечественного и импортного производства напрямую от производителей и с крупнейших складов мира.

Благодаря сотрудничеству с мировыми поставщиками мы осуществляем комплексные и плановые поставки широчайшего спектра электронных компонентов.

Собственная эффективная логистика и склад в обеспечивает надежную поставку продукции в точно указанные сроки по всей России.

Мы осуществляем техническую поддержку нашим клиентам и предпродажную проверку качества продукции. На все поставляемые продукты мы предоставляем гарантию .

Осуществляем поставки продукции под контролем ВП МО РФ на предприятия военно-промышленного комплекса России , а также работаем в рамках 275 ФЗ с открытием отдельных счетов в уполномоченном банке. Система менеджмента качества компании соответствует требованиям ГОСТ ISO 9001.

Минимальные сроки поставки, гибкие цены, неограниченный ассортимент и индивидуальный подход к клиентам являются основой для выстраивания долгосрочного и эффективного сотрудничества с предприятиями радиоэлектронной промышленности, предприятиями ВПК и научно-исследовательскими институтами России.

С нами вы становитесь еще успешнее!

Наши контакты:

Телефон: +7 812 627 14 35

Электронная почта: sales@st-electron.ru

Адрес: 198099, Санкт-Петербург,
Промышленная ул, дом № 19, литера Н,
помещение 100-Н Офис 331