



32K X 8 BIT LOW POWER CMOS SRAM

FEATURES

- 32768x8 bit static CMOS RAM
- Access times 70 ns
- Common data inputs and data outputs
- Three-state outputs
- Typ. operating supply current
 - 70 ns: 50 mA
- TTL/CMOS-compatible
- Automatical reduction of power dissipation in long Read Cycles
- Power supply voltage 5V + 10%
- Operating temperature ranges
 - 0 to 70 °C
 - -40 to 85 °C
- QS 9000 Quality Standard
- ESD protection > 2000 V (MIL STD 883C M3015.7)
- Latch-up immunity >100 mA
- Packages: PDIP28 (600 mil)
SOP28 (330 mil)

DESCRIPTION

The AS6C62256A is a static RAM manufactured using a CMOS process technology with the following operating modes:

- Read - Standby
- Write - Data Retention

The memory array is based on a 6-transistor cell.

The circuit is activated by the falling edge of E. The address and control inputs open simultaneously. According to the information of W and G, the data inputs, or outputs, are active. In a Read cycle, the data outputs are activated by the falling edge of G, afterwards the data word read will be available at the outputs DQ0-DQ7. After the address change, the data outputs go High-Z until the new information read is available. The data outputs have not preferred state.

The Read cycle is finished by the falling edge of W, or by the rising edge of E, respectively.

Data retention is guaranteed down to 2 V. With the exception of E, all inputs consist of NOR gates, so that no pull-up/pull-down resistors are required.

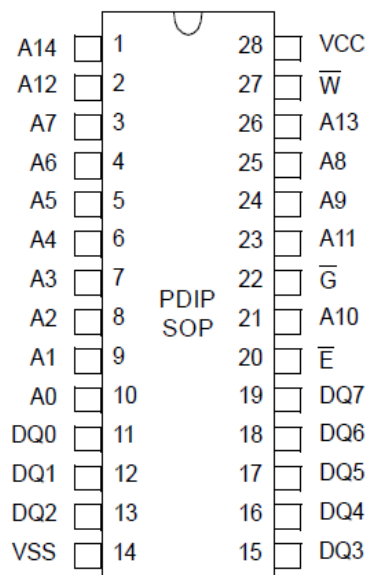
PIN CONFIGURATION

Top View

PIN DESCRIPTION

Signal Name	Signal Description
A0 - A14	Address Inputs
DQ0 - DQ7	Data In/Out
\bar{E}	Chip Enable
\bar{G}	Output Enable
\bar{W}	Write Enable
VCC	Power Supply Voltage
VSS	Ground



32K X 8 BIT LOW POWER CMOS SRAM

Block Diagram

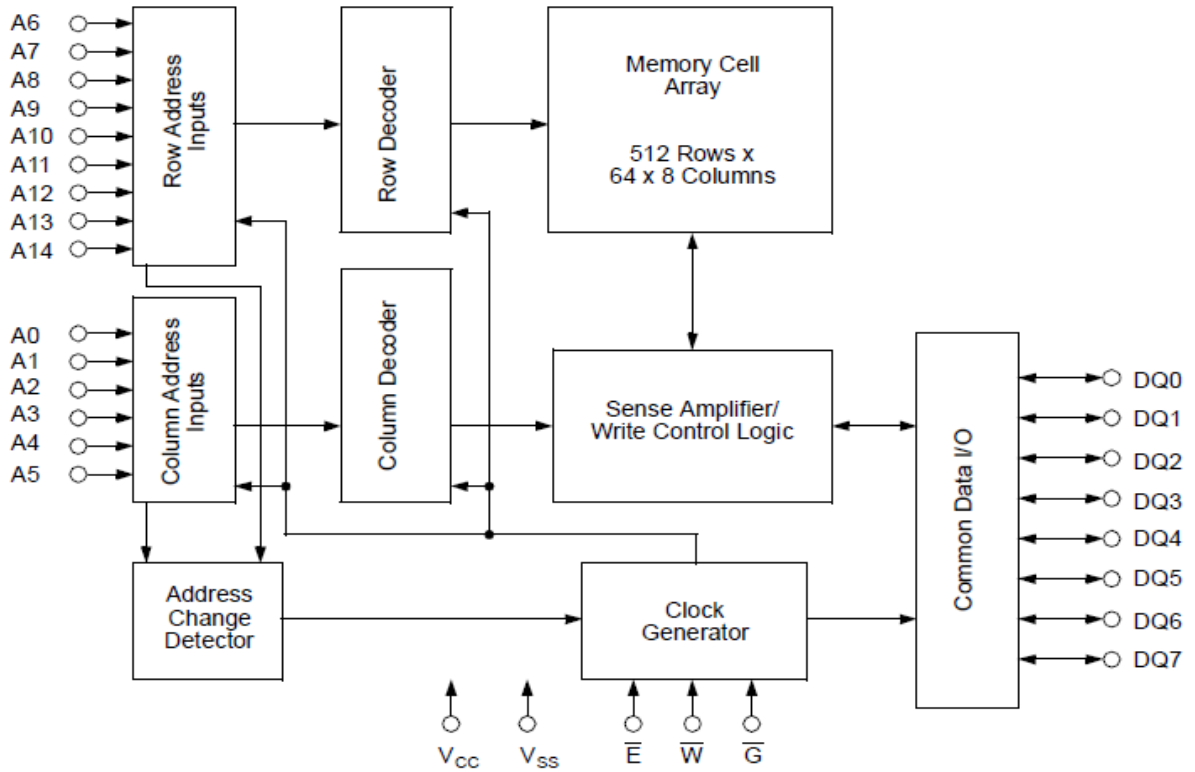

Truth Table

Operating Mode	\bar{E}	\bar{W}	\bar{G}	DQ0 - DQ7
Standby/not selected	H	*	*	High-Z
Internal Read	L	H	H	High-Z
Read	L	H	L	Data Outputs Low-Z
Write	L	L	*	Data Inputs High-Z

* H or L



32K X 8 BIT LOW POWER CMOS SRAM

Characteristics

All voltages are referenced to $V_{SS} = 0$ V (ground).

All characteristics are valid in the power supply voltage range and in the operating temperature range specified.

Dynamic measurements are based on a rise and fall time of ≤ 5 ns, measured between 10 % and 90 % of V_I , as well as input levels of $V_{IL} = 0$ V and $V_{IH} = 3$ V. The timing reference level of all input and output signals is 1.5 V, with the exception of the t_{dis} -times and t_{en} -times, in which cases transition is measured ± 200 mV from steady-state voltage.

Absolute Maximum Ratings ^a		Symbol	Min.	Max.	Unit
Power Supply Voltage		V_{CC}	-0.5	7	V
Input Voltage		V_I	-0.5	$V_{CC} + 0.5$ ^b	V
Output Voltage		V_O	-0.5	$V_{CC} + 0.5$ ^b	V
Power Dissipation		P_D	-	1	W
Operating Temperature	C-Type	T_a	0	70	°C
	I-Type		-40	85	
Storage Temperature	C/I-Type	T_{stg}	-65	125	°C
Output Short-Circuit Current at $V_{CC} = 5$ V and $V_O = 0$ V ^c		$ I_{OS} $		200	mA

^a Stresses greater than those listed under „Absolute Maximum Ratings“ may cause permanent damage to the device. This is a stress rating only, and functional operation of the device at condition above those indicated in the operational sections of this specification is not implied. Exposure to absolute maximum rating conditions for extended periods may affect reliability

^b Maximum voltage is 7 V

^c Not more than 1 output should be shorted at the same time. Duration of the short circuit should not exceed 30 s.

Recommended Operating Conditions	Symbol	Conditions	Min.	Max.	Unit
Power Supply Voltage	V_{CC}		4.5	5.5	V
Input Low Voltage ^d	V_{IL}		-0.3	0.8	V
Input High Voltage	V_{IH}		2.2	$V_{CC} + 0.3$	V

^d -2 V at Pulse Width 10 ns



32K X 8 BIT LOW POWER CMOS SRAM

Electrical Characteristics	Symbol	Conditions	Min.	Max.	Unit
Supply Current - Operating Mode	$I_{CC(OP)}$	$V_{CC} = 5.5\text{ V}$ $V_{IL} = 0.8\text{ V}$ $V_{IH} = 2.2\text{ V}$ $t_{cW} = 70\text{ ns}$		70	mA
Supply Current - Standby Mode (CMOS level)	$I_{CC(SB)}$	$V_{CC} = 5.5\text{ V}$ $V_{\bar{E}} = V_{CC} - 0.2\text{ V}$ C-Type I-Type		5 10	μA μA
Supply Current - Standby Mode (TTL level)	$I_{CC(SB)1}$	$V_{CC} = 5.5\text{ V}$ $V_{\bar{E}} = 2.2\text{ V}$		1	mA
Output High Voltage	V_{OH}	$V_{CC} = 4.5\text{ V}$ $I_{OH} = -1.0\text{ mA}$	2.4		V
Output Low Voltage	V_{OL}	$V_{CC} = 4.5\text{ V}$ $I_{OL} = 3.2\text{ mA}$		0.4	V
Input High Leakage Current	I_{IH}	$V_{CC} = 5.5\text{ V}$ $V_{IH} = 5.5\text{ V}$		2	μA
Input Low Leakage Current	I_{IL}	$V_{CC} = 5.5\text{ V}$ $V_{IL} = 0\text{ V}$	-2		μA
Output High Current	I_{OH}	$V_{CC} = 4.5\text{ V}$ $V_{OH} = 2.4\text{ V}$		-1	mA
Output Low Current	I_{OL}	$V_{CC} = 4.5\text{ V}$ $V_{OL} = 0.4\text{ V}$	3,2		mA
Output Leakage Current High at Three-State Outputs	I_{OHZ}	$V_{CC} = 5.5\text{ V}$ $V_{OH} = 5.5\text{ V}$		1	μA
Low at Three-State Outputs	I_{OLZ}	$V_{CC} = 5.5\text{ V}$ $V_{OL} = 0\text{ V}$	-1		μA



32K X 8 BIT LOW POWER CMOS SRAM

Switching Characteristics Read Cycle	Symbol		07		Unit
	Alt.	IEC	Min.	Max.	
Read Cycle Time	t_{RC}	t_{cR}	70		ns
Address Access Time to Data Valid	t_{AA}	$t_{a(A)}$		70	ns
Chip Enable Access Time to Data Valid	t_{ACE}	$t_{a(E)}$		70	ns
Output Enable Access Time to Data Valid	t_{OE}	$t_{a(G)}$		35	ns
\bar{E} HIGH to Output in High-Z	t_{HZCE}	$t_{dis(E)}$		25	ns
\bar{G} HIGH to Output in High-Z	t_{HZOE}	$t_{dis(G)}$		25	ns
\bar{E} LOW to Output in Low-Z	t_{LZCE}	$t_{en(E)}$	5		ns
\bar{G} LOW to Output in Low-Z	t_{LZOE}	$t_{en(G)}$	0		ns
Output Hold Time from Address Change	t_{OH}	$t_{v(A)}$	5		ns

Switching Characteristics Write Cycle	Symbol		07		Unit
	Alt.	IEC	Min.	Max.	
Write Cycle Time	t_{WC}	t_{cW}	70		ns
Write Pulse Width	t_{WP}	$t_{w(W)}$	55		ns
Write Pulse Width Setup Time	t_{WP}	$t_{su(W)}$	55		ns
Address Setup Time	t_{AS}	$t_{su(A)}$	0		ns
Address Valid to End of Write	t_{AW}	$t_{su(A-WH)}$	65		ns
Chip Enable Setup Time	t_{CW}	$t_{su(E)}$	65		ns
Pulse Width Chip Enable to End of Write	t_{CW}	$t_{w(E)}$	65		ns
Data Setup Time	t_{DS}	$t_{su(D)}$	30		ns
Data Hold Time	t_{DH}	$t_{h(D)}$	0		ns
Address Hold from End of Write	t_{AH}	$t_{h(A)}$	0		ns
\bar{W} LOW to Output in High-Z	t_{HZWE}	$t_{dis(W)}$		25	ns
\bar{G} HIGH to Output in High-Z	t_{HZOE}	$t_{dis(G)}$		25	ns
\bar{W} HIGH to Output in Low-Z	t_{LZWE}	$t_{en(W)}$	0		ns
\bar{G} LOW to Output in Low-Z	t_{LZOE}	$t_{en(G)}$	0		ns



32K X 8 BIT LOW POWER CMOS SRAM

Data Retention Mode

\bar{E} -Controlled

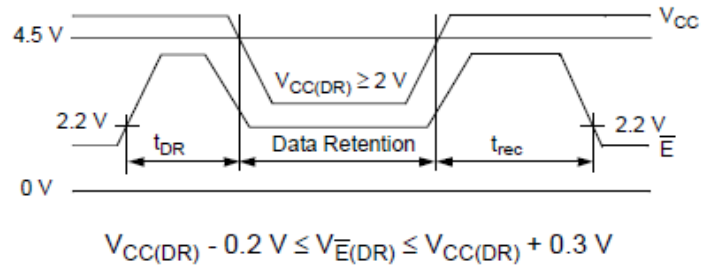

Data Retention Characteristics	Symbol Alt.	IEC	Conditions	Min.	Typ.	Max.	Unit
Data Retention Supply Voltage		$V_{CC(DR)}$		2		5.5	V
Data Retention Supply Current		$I_{CC(DR)}$	$V_{CC(DR)} = 3\text{ V}$ $V_{\bar{E}} = V_{CC(DR)} - 0.2\text{ V}$ C-Type I-Type			3 6	μA μA
Data Retention Setup Time	t_{CDR}	$t_{su(DR)}$	See Data Retention Waveforms (above)	0			ns
Operating Recovery Time	t_R	t_{rec}		t_{cR}			ns

Test Configuration for Functional Check

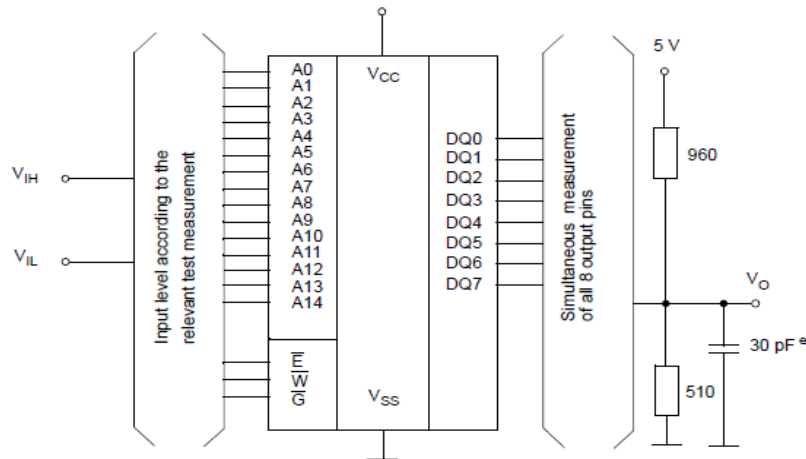

^e In measurement of $t_{dis(E)}$, $t_{dis(W)}$, $t_{dis(G)}$, $t_{en(E)}$, $t_{en(W)}$, $t_{en(G)}$ the capacitance is 5 pF.



32K X 8 BIT LOW POWER CMOS SRAM

Capacitance	Conditions	Symbol	Min.	Max.	Unit
Input Capacitance	$V_{CC} = 5.0\text{ V}$ $V_I = V_{SS}$	C_I	-	7	pF
Output Capacitance	$f = 1\text{ MHz}$ $T_a = 25\text{ }^\circ\text{C}$	C_O	-	7	pF

All pins not under test must be connected with ground by capacitors.

Device Marking (example)



ORDERING INFORMATION

Alliance	Organization	VCC Range	Package	Operating Temp	Speed ns
AS6C62256A-70SCN	32K x 8	4.5V – 5.5V	SOP28 (330 mil)	Commercial~ 0 C – 70 C	70
AS6C62256A-70SIN	32K x 8	4.5V – 5.5V	SOP28 (330 mil)	Industrial~ 40 C– 85 C	70
AS6C62256A-70PCN	32K x 8	4.5V – 5.5V	PDIP28 (600 mil)	Commercial~ 0 C – 70 C	70
AS6C62256A-70PIN	32K x 8	4.5V – 5.5V	PDIP28 (600 mil)	Industrial~ 40 C– 85 C	70

PART NUMBERING SYSTEM

AS6C	62256	A	-70	X	X	N
SRAM prefix	Device Number: Low Power (256K)	Die Rev	Access Time	Package Option: P=28pin 600mil PDIP S=28pin 330mil SOP	Temperature Range: C = Commercial (0 to 70 C) I = Industrial (40 to 85 C)	N = Lead Free RoHS compliant part



32K X 8 BIT LOW POWER CMOS SRAM

Read Cycle 1: Ai-controlled (during Read Cycle : $\overline{E} = \overline{G} = V_{IL}, \overline{W} = V_{IH}$)

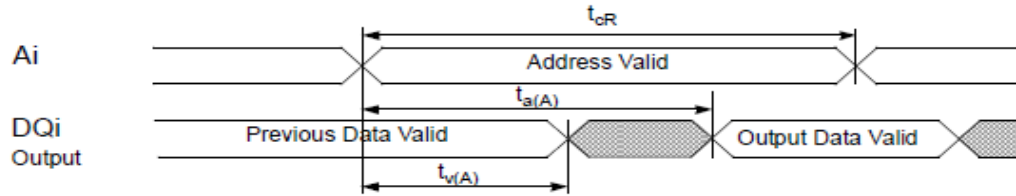

Read Cycle 2: \overline{G} -, \overline{E} -controlled (during Read Cycle: $\overline{W} = V_{IH}$)

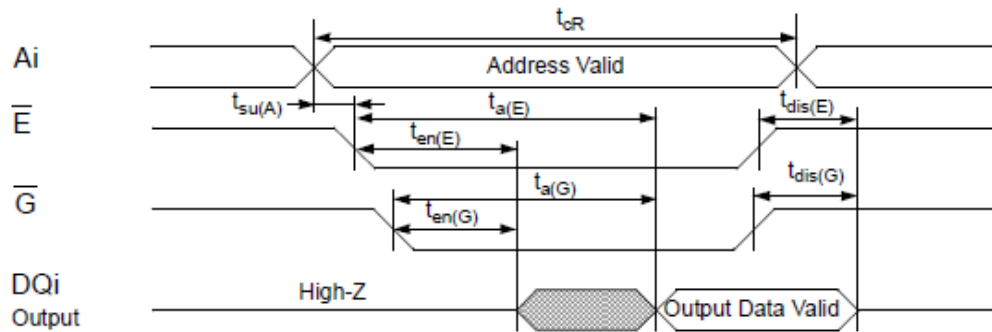



32K X 8 BIT LOW POWER CMOS SRAM

Write Cycle 1: \overline{W} -controlled

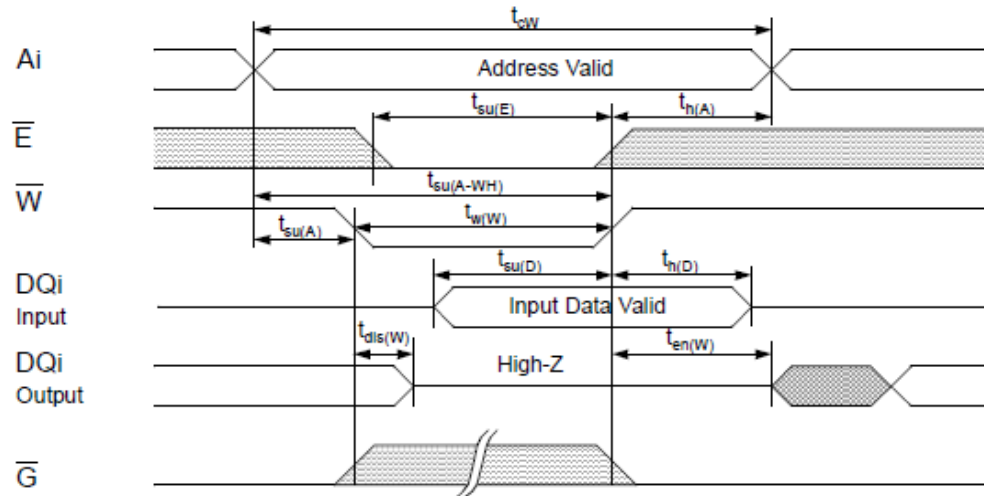

Write Cycle 2: \overline{E} -controlled

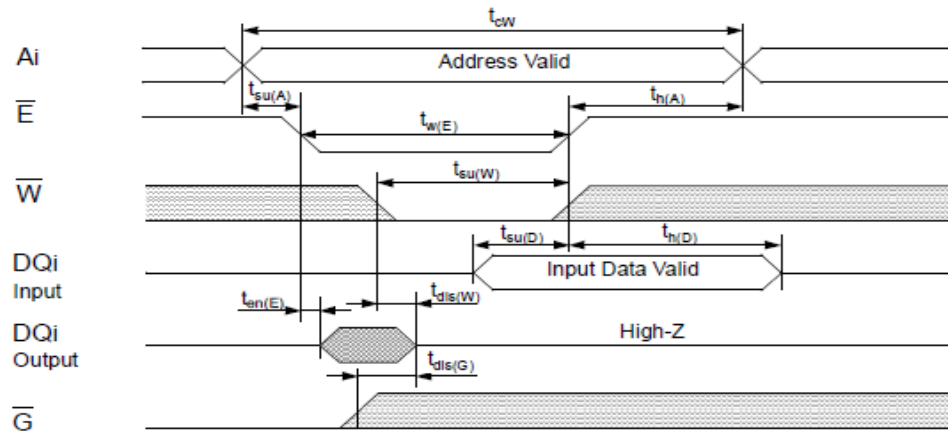

undefined  L- to H-level  H- to L-level 

The information describes the type of component and shall not be considered as assured characteristics. Terms of delivery and rights to change design reserved.



32K X 8 BIT LOW POWER CMOS SRAM



Alliance Memory, Inc
511 Taylor Way,
San Carlos, CA 94070, USA
Phone: 650-610-6800
Fax: 650-620-9211
www.alliancememory.com

Copyright © Alliance Memory
All Rights Reserved

© Copyright 2009 Alliance Memory, Inc. All rights reserved. Our three-point logo, our name and Intelliwatt are trademarks or registered trademarks of Alliance. All other brand and product names may be the trademarks of their respective companies. Alliance reserves the right to make changes to this document and its products at any time without notice. Alliance assumes no responsibility for any errors that may appear in this document. The data contained herein represents Alliance's best data and/or estimates at the time of issuance. Alliance reserves the right to change or correct this data at anytime, without notice. If the product described herein is under development, significant changes to these specifications are possible. The information in this product data sheet is intended to be general descriptive information for potential customers and users, and is not intended to operate as, or provide any guarantee or warranty to any user or customer. Alliance does not assume any responsibility or liability arising out of the application or use of any product described herein, and disclaims any express or implied warranties related to the sale and/or use of Alliance products including liability or warranties related to fitness for a particular purpose, merchantability, or infringement of any intellectual property rights, except as express agreed to in Alliance's Terms and Conditions of Sale (which are available from Alliance). All sales of Alliance products are made exclusively according to Alliance's Terms and Conditions of Sale. The purchase of products from Alliance does not convey a license under any patent rights, copyrights; mask works rights, trademarks, or any other intellectual property rights of Alliance or third parties. Alliance does not authorize its products for use as critical components in life-supporting systems where a malfunction or failure may reasonably be expected to result in significant injury to the user, and the inclusion of Alliance products in such life-supporting systems implies that the manufacturer assumes all risk of such use and agrees to indemnify Alliance against all claims arising from such use.



Стандарт Электрон Связь

Мы молодая и активно развивающаяся компания в области поставок электронных компонентов. Мы поставляем электронные компоненты отечественного и импортного производства напрямую от производителей и с крупнейших складов мира.

Благодаря сотрудничеству с мировыми поставщиками мы осуществляем комплексные и плановые поставки широчайшего спектра электронных компонентов.

Собственная эффективная логистика и склад в обеспечивает надежную поставку продукции в точно указанные сроки по всей России.

Мы осуществляем техническую поддержку нашим клиентам и предпродажную проверку качества продукции. На все поставляемые продукты мы предоставляем гарантию .

Осуществляем поставки продукции под контролем ВП МО РФ на предприятия военно-промышленного комплекса России , а также работаем в рамках 275 ФЗ с открытием отдельных счетов в уполномоченном банке. Система менеджмента качества компании соответствует требованиям ГОСТ ISO 9001.

Минимальные сроки поставки, гибкие цены, неограниченный ассортимент и индивидуальный подход к клиентам являются основой для выстраивания долгосрочного и эффективного сотрудничества с предприятиями радиоэлектронной промышленности, предприятиями ВПК и научно-исследовательскими институтами России.

С нами вы становитесь еще успешнее!

Наши контакты:

Телефон: +7 812 627 14 35

Электронная почта: sales@st-electron.ru

Адрес: 198099, Санкт-Петербург,
Промышленная ул, дом № 19, литера Н,
помещение 100-Н Офис 331